

The American

GAS LIGHT JOURNAL.

(ILLUSTRATED.)

DEVOTED TO THE INTERESTS OF

ILLUMINATION, HEATING, VENTILATION

AND

GENERAL SCIENCE.

VOLUME LII.

(THIRTY-SECOND YEAR.)

FROM JANUARY 1 TO JUNE 30, 1890.

A. M. CALLENDER & CO., Publishers,

OFFICE OF PUBLICATION, NO. 42 PINE STREET, NEW YORK CITY.

INDEX

—TO—

VOLUME LII.

January 1 to June 30, 1890.

- A**
- A Chapter of Don'ts, by W. H. Snow 393
*Addicks, W. R., Vaporization and Feed of Oil to Generator and Retort..... 356
Address, President's, New England Association. Robert B. Taber..... 278
Address, President's, Western Gas Association. Chas. R. Faben, Jr..... 766
Address, President's, Ohio Gas Light Association. Edward Lindsley..... 463
Adjournment of Ohio Gas Light Association..... 557
Advantages of a Combined Coal and Water Gas Plant, by Geo. A. Light..... 478
Advantages of Water Gas over Coal Gas for Small Works, by F. H. Parker..... 320
Advertisers. What They Say..... 354
Air Engine. A Hot..... 401
*Alavoine's Gas Washer..... 433
*Alexander & Paterson Process of Making Oil Gas..... 72
American Gas Light Association. Appointment of Committees at Meeting of Council..... 765
Amory, Dr., of Brookline, on Municipal Gas and Electric Lighting..... 281
Amendment to Constitution, New England Association..... 280
Ammoniacal Liquor. Economy of Fuel in the Distillation of, An Advance Budget from "Three Stars"..... 729
An Interesting Chapter in Photometrical Testing, and an Addendum by T. S. Cleminshaw..... 427
Annual Report (5th) of Massachusetts Gas and Electric Light Commissioners..... 140
Annual Meeting of the Springfield (Mass.) Gas Company.... 141
Another Loomis Patent in England..... 882
*Another Step in the Granger Process..... 71
A Point or Two in Regard to Illuminants During Condensation and Purification, by Geo. F. Goodno..... 391
*Apparatus for Manufacturing Gas. Close's..... 5
*Apparatus for Washing Gas. Dye's..... 698
Applications for, and Election to, Membership, New England Association..... 248
Appointing Special Committees, Western Gas Association.... 916
Appointment of Committees, Ohio Association..... 433
Aqueduct, Methods of Lighting Work on the New Croton... 74
Argument in Favor of the Municipal Ownership of Electric Lighting Plants, by Victor Rosewater..... 423
Assay of Coal..... 918
Associated Press Once More, The..... 801
Australia, Progress of the Electric Light in..... 699
- B**
- Badges, in the Matter of, New England Association. 355
Batch of Invitations, A. Western Association..... 912
Baths. Dangers of Gas and Geyser..... 735
Benson, Arthur W.—Obituary..... 2
*Blower. Steel Pressure..... 136
Boiling of Water is not a Guarantee of Purity, The..... 885
Boilers, Preventing the Incrustation of..... 249
Bowers, Geo. W., Combination of Gas and Electric Lighting in a Small Town..... 465
Brin's Process Company for New York, A..... 846
British Coal. The Possible Average Depth at which it is now Worked..... 214
British Gas Works, Water Gas for, by C. J. R. Humphreys... 210
Budget from "Three Stars," An Advance..... 729
Burners, Gas, for Illuminating Purposes..... 731
By-Products of Experience, by A. R. Foote..... 879
- C**
- *Carburetor for Gas Engines..... 40
Carcass Roofing, by J. Robinson..... 735
Car Lighting..... 172
*Charging Gas Retort Furnaces with Hot Residual Coke, Device for..... 210
*Charging Inclined Gas Retorts, Device for..... 428
Change of Interests in the Siemens-Lungren Company..... 801
- Cheapest Light, The..... 597
Chemistry of Illuminating Gas, by N. H. Humphrys..... 39
Chemistry of the Dinsmore Process..... 774
Chimney Proportion..... 44
*Chollar, B. E., Doubts Versus Dogmatism..... 485
Chollar, B. E., The Relative Value of Gaseous Fuels..... 802
Clark, Walton, The World's Fair and the Gas Associations.... 838
Claus' Method of Producing Water Gas and Obtaining Certain Bye Products..... 244
Cleminshaw, T. S., An interesting Chapter in Photometrical Testing, and an Addenda..... 427
*Close Gas Manufacturing Apparatus..... 5
Coal Industry, The Illinois..... 73
Coal Miners' Strike and London Fuel Supply..... 561
Coals in Western Canada, Notes on Some..... 662
Coal Fields of the State of Washington, by W. J. Wood..... 665
Coal, Assay of..... 918
Coke and Charcoal Compared..... 43
Coke Manufacture Utilization of Residuals from..... 104
Coke Brick for Furnace Linings..... 329
Combination of Gas and Electric Lighting in a Small Town, by Geo. W. Bowers..... 465
Combustion, Spontaneous, in Coal Ships..... 700
Competition, The Effect of Natural Gas, by Jas. Somerville.. 911
Conductors, Deterioration of Electrical..... 41
Connellsville Coke Trade, The..... 249
*Conroy's Cut-Off and Relief Apparatus for Gas Mains..... 558
Construction of Gas Holder Tanks..... 664
Controversy, The Incandescent Light..... 42
Conversion of Gas Globes into Regenerative Lamps..... 75
Corrosion..... 79
*Cash's Apparatus for the Manufacture of Gas..... 732
*Cowell's Device for Carrying off Leakage from Gas Mains.. 593
Cowdery, E. G., on Mixed Gases..... 910
Coze's System, Improvements on..... 178
Cushing, Oliver E., Death of..... 69
- COMMITTEES:—New England Association of Gas Engineers.—
Invitations, 248; President's Address, 280-391; Nomination of Officers, 281-326; Memorial, 281; World's Fair, 326-394; Badges, 326-394.
- Ohio Gas Light Association.—
Membership, 431; Executive, 431; Legislation, 431; Place of Next Meeting, 433; Nominations, 433-552; President's Address, 465; Location, 518.
- American Gas Light Association..... 765
- Western Gas Association.—
President's Address, 769-840; Board of Directors, 769; Membership, 769; On Examination of Books and Accounts of Secretary and Treasurer, 769; Visitors, 769; Nomination of Officers, 769-842; Resolutions, 769-916; Obituary Resolution, 769-808; Place of Next Meeting, 842-916; Gimper Paper, 842; Gas Companies' Accounts, 874; Arrangements, Louisville Meeting, 916.
- CORRESPONDENCE—
- Electric Lighting at St. Louis..... 969
Explosion at the St. Paul (Minn.) Gas Works. B. F. Ellisen..... 206
Dr. Wilkinson Objects to the Figures..... 70
Gas Companies Should Control the Introduction of Gas Stoves, by S. S. Stratton..... 705
The Lighting Situation at Fort Scott, Kas..... 145
- D**
- Danger, Fire, from Outside Electric Currents..... 397
Dangers of Gas and Geyser Baths..... 735
Dangers of Electric Lighting, by S. Z. de Ferranti and Francis Ince..... 138, *175
Death of Oliver E. Cushing..... 69, 101, 586
Death of Dr. Lull, President of the Dubuque (Iowa) Key City Gas Company..... 170
- Death of Alfred Arndt..... 808
Death of Arthur W. Benson..... 2
Death of Thomas A. Cosgrove..... 809
Death of Theobald Forstall..... 102
Death of Walter Burchard Houston..... 513
Death of James Henri Rollins..... 909
Death of Edward J. King..... 806, 808
Demand for More Light..... 139
Depth (the Possible Average) at Which Coal is Worked in England..... 214
Deterioration of Electrical Conductors..... 41
*Device for Charging Gas Retort Furnaces with Hot Residual Coke..... 210
*Device for Testing the Gradients of Pipes..... 212
*Device for Charging Inclined Retorts..... 428
Deville's, M. Sainte-Claire, Study of Coal Gas..... 207
Did Dr. Wilkinson Confine Himself to Facts? by James Somerville..... 695
Difference in the Eastern and Western Methods of Management of Gas Works, by E. G. Pratt..... 318
Dinsmore Process, The Chemistry of the..... 774
Dinsmore Process, The..... 9
Discharge of Steam through Orifices..... 633
Distributory Plant, Notes on..... 695
Don'ts, A Chapter of, by W. H. Snow..... 393
*Doubts Versus Dogmatism, by B. E. Chollar..... 485
Draft, Chimney, Note on Rankine's Treatment of, by Prof. J. B. Webb..... 171
*Dye's Apparatus for Washing Gas..... 698
- E**
- Economical Engine for Small Power, On the Most..... 217
Economy of Fuel in the Distillation of Ammoniacal Liquor.. 365
Education, Technical..... 213
Egner, Frederic. Practical Hints on Purification with Lime.. 462
Egner, Frederic. A Page from Experience with an Exhauster. 3
Egner, Frederic, On the Abuse of the Patent System, with a Remedy..... 770
Election of New Members, Ohio Gas Light Association..... 432
Election of Officers, Ohio Gas Light Association..... 552
Election of Officers, New England Association..... 326
Election of New Members, Western Gas Association..... 802
Election of Officers, Western Gas Association..... 842
Electing Mr. H. B. Leach to Honorary Membership, Western Association..... 802
Electric Lighting of Ships..... 75
Electric Wiring in Boston Buildings, Proposed Legislation in the Matter of..... 3
Electric Lighting, Dangers of, by S. Z. de Ferranti and Francis Ince..... 133, *175
*Electric Meters, Three Types of..... 176
Electric Tests, Influence of Temperature on..... 181
Electric Light at the British Museum..... 217
Electric Currents, Fire Dangers from Outside..... 397
Electric Units, Thoughts on..... 398
Electric Conductors, Deterioration of..... 41
Electric Ignition of Gas Engines..... 697
Electricians, The Vagaries of the..... 212
Engine, Hot Air..... 401
Engineers, Useful Memoranda and Information for..... 705
English Lighting Methods, President Peaty's Views on the Status of..... 390
Evans, C. H. Another Year with Fuel Gas..... 515
Exhaust and Pressure Registers and Pressure Gauges..... 71
Examination of Commercial Glycerine..... 7
*Experience with Subsidized Gas Mains..... 557
Experiments on the Relation of Electric Lamps to Combustible Bodies..... 38
Exhibition of Gas Apparatus, Western Gas Association..... 809
Excavating, The Poetsch System of, by E. L. Abbott..... 734
Experiments in the Photometer Room, by N. W. Gifford.... 317
- EDITORIALS—
- A Banquet Response..... 426
A Bad Verdict..... 730

665.05
AM
v.52

INDEX TO VOL. LII.

A Correction..... 874
 A Correction..... 622
 An Application for an Opposition Charter at Freeport, Ill. 70
 A Model Circular..... 514
 Annual Meeting, Port Hope (Ont.) Gas Company..... 802
 Annual Meeting, Lebanon, Pa..... 37
 Annual Meeting, Clinton, Mass..... 242
 Annual Report, Superintendent of Public Lamps, Boston, Mass..... 242
 Annual Meeting, Bridgeport, Conn..... 550
 Annual Meeting, Rochester, Minn..... 550
 An Old-New Firm..... 37
 Another Instalment from the Western's Secretary..... 586
 Arc Lighting at Boston, Mass..... 69
 Attempting to Settle the Baltimore (Md.) Gas Question.. 206
 A Weekly Edition of the Electrical Engineer..... 390
 Bids for Public Lighting, New York City..... 513
 Cheaper Gas for Peoria, Ill..... 170
 Dearer Gas for London..... 874
 Death of Dr. Lull..... 170
 Death of Mr. Wm. H. McClave..... 390
 Doings of the Davis & Farnum Manufacturing Company. 874
 Electric Light Installations, etc..... 314
 Exhibits and Exhibitors at the Western Gas Association.. 801
 Exit the Wakefield Manufacturing Company..... 658
 Flemming Benches at Philadelphia..... 134
 Further Hints from Alton, Ill..... 837
 Gas Stocks as Investments..... 37
 Hints from Alton, Ill..... 461
 How Things are Going Along at Ironton, Ohio..... 837
 In Bad Faith..... 278
 Mandamus Proceedings, Supreme Court, Philadelphia, Decided Against the Trustees of the Roman Catholic High School..... 134
 Mayor Noonan Routs the St. Louis Gas Grabbers..... 2
 Mr. Todd's Policy..... 658
 Mr. Hallett's Success at Springfield, Mass..... 134
 Mr. Hallett's Resignation from the Springfield Company. 134
 Mr. Greenough on Municipal Light Supply..... 390
 Mr. Stedman Tells the Whole Truth..... 910
 Mr. Vorke Writes a Book..... 837
 Notes—Editorial..... 514, 550, 586, 622, 658, 694, 730, 802, 838
 Obituary—James Henri Rollins..... 909
 Obituary—Resolutions—Society of Gas Lighting..... 586
 Obituary—Oliver E. Cushing..... 101
 Obituary—Theobald Forstall..... 102
 Obituary Note—William Parrish, Seneca Falls, N. Y..... 134
 Obituary Note—Walter Burchard Houston..... 513
 Opposition at St. Joseph, Mo..... 354
 On to Washington Once More..... 550
 Public Lighting Awards, New York City..... 586
 Putting the Blame Where it Belongs..... 873
 Recommending a Change in the Massachusetts Carbonic Oxide Regulations..... 206
 Scant Justice..... 461
 The Amendment was not Accepted by the Gas Company.. 69
 The Day is at Hand..... 694
 The Entertainment Programme for the St. Louis Meeting 658
 The Gas Works Safe at Louisville, Ky..... 425
 The Gas Exhibit at St. Louis..... 622
 The Gas Statistics Branch of the Eleventh Census..... 694
 The Latest Gun from Toledo..... 314
 The Meeting at Toledo..... 389
 The Meeting at Dallas, Texas..... 314
 The New England's Twentieth Annual..... 170
 The Paper List for the St. Louis Convention..... 622
 The Rhode Island Gas Grab..... 461
 The Slater and Parker Papers..... 314
 The Toledo Meeting..... 278
 The Toledo Convention..... 425
 The Western's Thirteenth Annual..... 765
 *The Western Gas Association Cup..... 838
 The Wakefield Manufacturing Company..... 426
 The Western's Thirteenth Annual..... 549
 The Year's Record..... 1
 Tidings from the New England Meeting..... 241
 Uniform Them..... 462
 What Advertisers Say..... 354

F

Faben, Charles R., Jr. Graduated vs. Uniform Rates..... 468
 Faben, Charles R., Jr. Inaugural Address Western Gas Association..... 766
 Facts and Figures Connected with the Installation and Operation of an Electric Light Plant, by John J. Power..... 314
 Fair, The World's, and the Gas Associations, by Walton Clark 838
 Felling an Electric Light Pole, Operation of..... 137
 Ferranti, de, S. Z. and Francis Ince. Dangers of Electric Lighting..... 138-175
 Fields for Scientific Research..... 659
 Financial Aspect of Natural Gas, by Charles Harrison..... 177
 Fire, Danger from Outside Electric Currents..... 397
 Flames..... 881
 *Flannery's Patent Gas and Liquid Holder..... 135
 Foote, A. R., By-Products of Experience..... 879
 Foote, A. R. Municipal Control of Gas and Electric Light Plants..... 474
 *Former for Square Pipe..... 75
 *Fouli's Regenerative Furnace..... 41

Foundations, The Limiting Pressure Upon..... 105
 Fowler, S. J. Management of a Small Gas and Electric Light Plant..... 324
 Fuel Gas, Notes on, by G. W. Goetz..... 362
 Fuel, Economy of, in the Distillation of Ammoniacal Liquor.. 365
 Fuel Gas, Another Year with, by C. H. Evans..... 515
 Furnace Linings, Coke Brick for..... 329

G

Gas Manufacturing Apparatus, Close..... 5
 Gas Stocks, 14, 146, 182, 218, 254, 270, 330, 366, 402, 437, 490, 526, 562, 598, 634, 670, 706, 742, 778, 886
 Gas Illuminating, Chemistry of, by N. H. Humphrys..... 39
 *Gas Engines, Carburetor for..... 40
 *Gas Washer, The Kusnezor..... 42
 *Gas, The Alexander and Paterson Process of Making Oil.... 72
 Gas Globes, Conversion of, into Regenerative Lamps..... 75
 *Gas and Liquid Holder, Flannery's..... 135
 Gas and Electricity, by Jno. West..... 172
 *Gas Engine, Test of an Otto, by E. Kidwell and E. R. Keller 208
 *Gas Washer, The Walker..... 211
 *Gasholder, The Northwich, on Messrs. Gadd & Mason's Principle, by Thomas Newbigging..... 243
 Gas Making, Profit in..... 250
 Gas, The Quality of, London..... 401
 *Gas Washer, Alavoines..... 433
 *Gas Fired Boiler, Thwaite's..... 523
 *Gas Manufacture, Leisner's Apparatus for..... 660
 Gas Engines with Electrical Ignition..... 697
 Gas Burners, for Illuminating Purposes..... 731
 *Gas, Cosh's Apparatus for the Manufacture of..... 732
 Gas and Geyser Baths, Dangers of..... 735
 Gas Apparatus Exhibition, Western Gas Ass'n..... 809
 Gas Accounts, The "Express Company" System of Collecting. 846
 Gas Light and Coke Company, and Their Men, The..... 881
 Gauges, and Pressure and Exhaust Registers, Pressure..... 71
 Gemunder, M. A., Municipal Control of Gas Works..... 473
 Gibbs, Prof. Wolcott, on Illuminating Gas..... 486
 Gimper, Surprises the Chair, Western Ass'n..... 769
 Glasgow Corporation Gas Works, The Three-Lift Holder at Dawsholm Station..... 427
 Glycerine, Examination of Commercial..... 7
 Goetz, G. W., Notes on Fuel Gas..... 362
 Goodno, Geo. F., A Point or Two in Regard to Illuminants during Condensation and Purification..... 391
 Graduated vs. Uniform Rates, by Chas. R. Faben, Jr..... 468
 *Granger Process, Another Step in the..... 71
 *Guiding for Gasholders, Terrace's Parallel Motion for..... 662

H

Hallett, J. L. Looking Backward..... 103
 Harrison, Charles. The Financial Aspect of Natural Gas.... 177
 Hatteras Light, The Proposed..... 249
 Hedges, W. C. Ohio Street Lighting Statistics, with Table of Prices..... 477
 Holder, The Three-Light, at Dawsholm Station of the Glasgow Corporation Gas Works..... 427
 Hot Air Engine..... 401
 How to Manage Steam Engines, by B. Taylor..... 846
 Humphrys, N. H., Chemistry of Illuminating Gas..... 39
 Humphrys, N. H., Special English Correspondence, 108, 286, 434, 594, 737, 917
 Humphreys, C. J. R. Water Gas for British Gas Works..... 210
 Hyde, G. A., Sr. Our New Coal Gas Works..... 482
 Hydraulic Engineering, Ingenious Expedient in..... 705

I

Identity of Light and Electric Radiation, The..... 700
 Illuminating Gas, Prof. Wolcott Gibbs, on..... 486
 " " Chemistry of, by N. H. Humphrys..... 39
 Illinois Coal Industry..... 73
 Illuminating Power and Specific Gravity of Coal Gas..... 136
 Illuminants, A Point or Two in regard to same during Condensation and Purification, by Geo. F. Goodno..... 391
 *Impressions of British Gas Works, by Geo. T. Thompson.... 843
 Improvements on Coze's System..... 178
 Inaugural Address, Western Gas Assn., Chas. R. Faben, Jr... 766
 India, Oil in..... 774
 Ince, Francis, and S. Z. de Ferranti, Dangers of Electric Lighting..... 138-175
 Incandescent Light Controversy..... 42
 Incrustation of Boilers, Preventing the..... 219
 Incandescent Lamps on Buoys..... 7
 Incandescent Lamp Bulbs, Tinting..... 251
 Increasing the Consumption of Gas for Cooking and Heating Purposes. A Method of..... 592
 *Indicator, The Meyer Valve..... 396
 Influence of an Idea..... 485
 Influence of Temperature on Electric Tests..... 181
 Ingenious Expedient in Hydraulic Engineering..... 705
 In Memoriam, Mr. Oliver E. Cushing..... 396
 In Memoriam Proceedings, Western Gas Assn: (Eulogizing Ex-President Edward J. King)..... 806
 The Forstall Memorial..... 808

The King Memorial..... 808
 The Arndt "..... 808
 The Cosgrove "..... 809
 The Fullagar "..... 809
 Introducing the President-Elect, Western Gas Assn..... 842
 " Visitors, "..... 769
 In the Matter of Badges, New England Assn..... 355
 Introducing the New Members, Ohio Gas Light Assn..... 519
 Invitations, A Batch of, Western Gas Association..... 912
 Invitations, Reading the, New England Association..... 281
 Iron Work, Paints and Painting for..... 107
 Items of Interest from Various Localities, 11, 45, 77, 109, 142, 179, 214, 251, 287, 327, 363, 399, 435, 487, 523, 559, 595, 630, 677, 702, 739, 775, 811, 847, 883, 919

J

Jackets, Steam, Their Mode of Action and the Reasons of their Economy..... 8
 *Jones' Safety Device for Gas or Air Pipes..... 624

K

*Kidwell, E., and E. R. Keller. Test of an Otto Gas Engine. 208
 King, Edward J. In Memoriam Resolutions..... 806
 Mr. Ramsdell's Tribute..... 806
 Capt. W. H. White's Tribute..... 807
 Mr. James Somerville's Tribute..... 808
 *Kusnezor Gas Washer..... 42

L

Labor-Saving Appliances for the Manufacture of Coal Gas, by William Mooney..... 623
 Lamps, Incandescence, on Buoys..... 7
 Leach, H. B., Elected to Honorary Membership, Western Gas Association..... 802
 *Leakage from Gas Mains, Cowell's Device for Carrying off.. 593
 Learned, W. A., on the Revivification of Oxide of Iron..... 316
 Legislation in the Matter of Electric Wiring in Boston Buildings..... 3
 *Leisner's Apparatus for Manufacturing Gas..... 660
 Letters of Regret, Ohio Gas Light Association..... 432
 Letters of Regret, New England Association of Gas Engineers 248
 Light, Demand for More..... 139
 Light, Electric, at the British Museum..... 217
 Light, Geo. A. Advantages of a Combined Coal and Water Gas Plant..... 478
 Light, The Cheapest..... 597
 Lighting Work on the New Croton Aqueduct, Method of..... 74
 Lighting of an Imperial Railway Train..... 75
 Lighting of Ships, Electric..... 75
 Lighting Cars..... 172
 Lighting the Bottom of the Sea, An Ingenious Device for.... 633
 Lime, Practical Hints on Purification with, by F. Egner..... 462
 Life and Efficiency of Electric Arc Light Carbons, by L. B. Marks..... 628
 Limiting Pressure upon Foundations, The..... 105
 Lindsley, Edward. President's Address Ohio Gas Light Association..... 463
 *Lock-Joint Pipe, Matheson's..... 881
 London. The Gas Light and Coke Company and Their Men.. 881
 London Gas, The Quality of..... 401
 Looking Backward, by J. L. Hallett..... 103
 Loomis Patent in England, Another..... 882
 Lubricants, Notes on the Action of, by Prof. J. E. Denton. . 629
 Luminous Paint..... 181

M

Mains (Street), Which is the Best Material for, Wrought Iron, Cast Iron or Steel, by Eugene Printz..... 912
 Management of Gas Works, Difference in Eastern and Western Methods, by E. G. Pratt..... 318
 Management of a Small Gas and Electric Light Plant, by S. J. Fowler..... 324
 Manufacture of Water Gas, Mr. Trewby on the..... 106
 Manufacture of Oxygen for Industrial Use..... 396
 Manure, Sulphate of Ammonia as a..... 315
 Market for Gas Securities, 2, 38, 70, 102, 146, 182, 206, 242, 290, 330, 365, 402, 437, 462, 514, 550, 586, 622, 658, 694, 730, 777, 802, 838, 874, 910
 Marks, L. B., Life and Efficiency of Electric Arc Light Carbons. 628
 Massachusetts Supreme Judicial Court Differs from Attorney-General Waterman..... 809
 Massachusetts Board of Gas and Electric Light Commissioners' Fifth Annual Report..... 140
 Massachusetts Board of Gas and Electric Light Commissioners on the Subject of Water Gas..... 24
 *Matheson's Patent Lock-Joint Pipe.....
 *Measuring Electric Lighting Values, Note on a new Photometer for..... 810
 Meeting, Place of, New England Association..... 396
 Measurements, Modern..... 917
 Melting Steel by Water Gas..... 633
 Memorial to the late Mr. Oliver E. Cushing..... 396
 *Meters, Three Types of Electric..... 176

INDEX TO VOL. LII.

Method of Increasing the Consumption of Gas for Cooking and Heating Purposes..... 592
 Methods of Lighting Work on the New Croton Aqueduct... 74
 *Meyer Valve Indicator..... 396
 Mixed Gases, by E. G. Cowdery..... 910
 Mooney, Wm., Labor-Saving Devices for the Manufacture of Coal Gas..... 623
 Most Economical Engine for Small Power..... 217
 Municipal Control of Gas and Electric Lighting, by Dr. Amory 281
 Municipal Ownership of Electric Lighting Plants, An Argument in Favor of the, by Victor Rosewater..... 429
 Municipal Control of Lighting, by H. Wilkiemeyer..... 471
 Municipal Control of Gas Works, by M. A. Gemunder..... 473
 Municipal Control of Gas and Electric Plants, by A. R. Foote. 474

N

Naphthaline, Mr. Watson Smith on..... 6
 Natural Gas, The Financial Aspect of, by Charles Harrison... 177
 New Members, Election of, Ohio Gas Light Association.... 432
 New Members, Introduction of, Ohio Gas Light Association.. 519
 News from the Absent Secretary, New England Association.. 326
 *Northwich Gasholder, on Messrs. Gadd and Mason's Principle, by Thomas Newbigging, C. E..... 243
 Norton, H. A. Various Methods of Introducing Gas Stoves.. 322
 Notes Taken in a Small Gas Works, by Ralph Woodward..... 355
 Notes on Fuel Gas, by G. W. Goetz..... 362
 Notes on the Action of Lubricants, by Prof. J. E. Denton..... 629
 Notes on Some Coals in Western Canada..... 622
 Notes on Distributary Plant..... 695

O

OBITUARY—

Alfred Arndt..... 808
 Arthur W. Benson..... 2
 Thomas A. Cosgrove..... 809
 Oliver E. Cushing..... 69, 101
 Theobald Forstall..... 102
 Walter Burchard Houston..... 513
 Edward J. King..... 803, 808
 James Henri Rollins..... 909
 Obituary Resolutions Society of Gas Lighting..... 586

OFFICIAL NOTICES—

Western Gas Association..... 513, 549, 585, 621, 657, 693
 New England Association of Gas Engineers... 37, 69, 101, 133, 169, 205
 Ohio Gas Light Association... 101, 133, 169, 203, 241, 277, 313, 353
 South Western Gas Association..... 277, 313

OFFICIAL REPORTS—

Twentieth Annual Meeting of the New England Association of Gas Engineers..... 248, 278, 316, 355, 391
 Thirteenth Annual Meeting of the Western Gas Association..... 766, 802, 838, 874, 910
 Sixth Annual Meeting of the Ohio Gas Light Association..... 431, 463, 515, 551
 Oil in India..... 774
 On Testing Materials..... 663
 Opinion of the Attorney-General of Massachusetts in Respect to the Rights of Cities and Towns to Operate Gas and Electric Light Plants..... 738
 Operation of Felling an Electric Light Pole..... 137
 Origin of the Rock Pressure of Natural Gas in the Trenton Limestone of Ohio and Indiana..... 105
 Our New Coal Gas Works, by G. A. Hyde, Sr..... 482
 Oxygen for Industrial Use, The Manufacture of..... 396

P

Paint, Luminous..... 181
 Paints and Painting for Iron Work..... 107
 Parker, F. H., A Few of the Advantages of Water Gas over Coal Gas for Small Works..... 320
 Patent Issues, Recent..... 13, 145, 329, 437
 Patent System, On the Abuse of the, With a Remedy, by F. Egner..... 770
 *Paterson and Alexander Process of Making Oil Gas... 72
 Petroleum Market for 1889..... 44
 Petroleum in Servia..... 561
 Photometer Room, Some Experiments in the, by N.W. Gifford. 317
 Photometrical Testing, An Interesting Chapter in, with Addenda, by T. S. Cleminshaw..... 427
 *Photometer, Note on a New, for Measuring Electric Lighting Values..... 810
 Pile Protection..... 140
 *Pipes, Jones' Safety Device for Gas or Air..... 624
 *Pipe, Matheson's Lock-Joint..... 881
 Place of Meeting New England Association..... 396
 Poetsch System of Excavating, The, by E. L. Abbott..... 734
 *Portable Photometer for Electric Lights..... 733
 Postponing the Election of New Members, Western Gas Association,..... 769

Power, John J., Facts and Figures Connected with the Installation and Operation of an Electric Light Plant..... 314
 Pratt, E. G., on Difference in Eastern and Western Methods of Management of Gas Works..... 318
 Pressure Gauges and Pressure and Exhaust Registers..... 71
 Pressure upon Foundations, The Limiting..... 105
 Pressure Blower, Steel..... 136
 Preventing the Incrustation of Boilers..... 249
 President's Address, New England Association, Robt. B. Taber..... 278
 President Peaty's Views on the Status of English Lighting Methods..... 390
 President's Address, Edward Lindsley, Ohio Gas Light Association..... 463
 President's Address, Western Gas Association, Chas. R. Faben, Jr..... 766
 Preservation of Wood by Chemical Means..... 666
 *Prindle's Retort Lid..... 4
 Printing of Papers, New England Association..... 326
 Printz, Eugene, Street Mains, Which is Best Material for, Wrought Iron, Cast Iron or Steel..... 912
 Proposed Hatteras Light, The..... 249
 Profit in Gas Making..... 250
 Problems Constantly before the Gas Manager, by E. H. Yorke..... 359
 Profit Sharing..... 625
 Progress of the Electric Light in Australia..... 699
 Public Lighting Bids for New York City..... 513
 Public Street Lighting in New York..... 521
 Purifying Boxes, Is Plate Steel or Cast Iron the Best Construction for..... 478
 Purifying Boxes, What Treatment or Care Secures the Longest Life of..... 478
 Purification with Lime, Practical Hints on, by F. Egner..... 462

Q

Quality of London Gas..... 401
 Question-Box, New England Association..... 394
 Effect of Oil as an Enricher on Meters..... 394
 Dissatisfaction Caused by Reduction, to Users of Gas Stoves..... 364
 Number of Days to allow for Payment of Gas Bills..... 394
 Repairing Leaks Temporarily in Holders..... 395
 Question-Box, Ohio Gas Light Association..... 519-551-555
 Does a fine Gas of 23 to 25 Candles Help Check the Invasion of the Electric Light..... 520
 Is Not Illuminating Gas of the Requisite Candle Power, Sold at a Reduced Price for Fuel, the True Solution of the Fuel Gas Problem..... 552

R

Radiation, Electric, and the Identity of Light..... 700
 *Rankine's Treatment of Chimney Draft, by Prof. J. B. Webb 171
 Raw Material in Gas Manufacture, The Waste of..... 627
 Reading the Invitations, New England Association..... 281
 Reading the Papers, Western Gas Association..... 770
 Recent Patent Issues:—13-145-329-437
 *Regenerative Furnace, The Foulis..... 41
 Relation of Electric Lamps to combustible Bodies, Experiments on the..... 38
 *Relief Apparatus and Cut-Off for Gas Mains, Conroy's... 558
 Relative Value of Gaseous Fuel, by B. E. Chollar..... 802
 Report of Treasurer, New England Association..... 280
 Report of Treasurer, Western Gas Association..... 769
 Report of Treasurer, Ohio Gas Light Association..... 432
 Report of Secretary, Ohio Gas Light Association..... 431
 Residuals from Coke Manufacturers, Utilization of.... 104
 Results from the Van Steenberg Water Gas Apparatus..... 354
 Resistance to Fire of Wood Posts..... 774
 *Retort Lid, Prindle's..... 4
 Revivification of Oxide of Iron, by W. A. Learned..... 316
 Rights of Cities and Towns to Operate Gas and Electric Light Plants; Opinion of Attorney General of Mass. in Respect to the..... 738
 Rock Pressure of Natural Gas in the Trenton Limestone of Ohio and Indiana, Origin of the..... 105
 Roll Call, New England Association..... 248
 Roll Call, Ohio Gas Light Association..... 432
 Roll Call, Western Gas Association..... 766
 Rollins, James Henri, Obituary..... 909
 Roofing, Carcass, by J. Robinson..... 735
 Rosewater, Victor, An Argument in Favor of the Municipal Ownership of Electric Lighting Plants..... 429

S

*Safety Device for Gas or Air Pipes, Jones'..... 624
 Scientific Research, Fields for..... 659
 Servia, Petroleum in..... 561
 Sharing, Profit..... 625
 Ships, Electric Lighting of..... 75
 Slater, A. B., on Why I Shall Make Water Gas..... 320
 Smith, Watson, on Naphthaline..... 6
 Snow, W. H., A Chapter of Don'ts..... 393
 Some Experiments in the Photometer Room, by N.W. Gifford. 317

Some Facts Connected with the Manufacture of Water Gas, by Dr. W. A. Wilkinson..... 587
 Somerville, Jas., Did Dr. Wilkinson Confine Himself to Facts? 695
 Somerville, Jas., The Effect of Natural Gas Competition..... 911
 Special English Correspondence, by N. H. Humphrys..... 108, 286, 434, 594, 737, 917
 Specific Gravity and Illuminating Power of Coal Gas..... 136
 Spontaneous Combustion in Coal Ships..... 700
 Springfield (Mass.) Gas Company, Annual Meeting..... 141
 *Square Pipe, Former for..... 75
 Steam Jackets, Their Mode of Action, and the Reasons of their Economy..... 8
 Steam Discharge Through Orifices..... 633
 *Steel Pressure Blower..... 136
 Steel Melting by Water Gas..... 633
 Street Lighting Statistics, Ohio, by W. C. Hedges (with Table of Prices)..... 477
 Street Lighting Statistics, New York, Public..... 521
 Study of Coal Gas, M. Sainte-Claire Deville's..... 207
 Subsidized Gas Mains, Experience with..... 557
 Sulphate of Ammonia as a Manure..... 315
 Sundry Matters, Ohio Gas Light Association..... 477
 Supreme Judicial Court of Massachusetts Differs from Attorney-General Waterman..... 809

T

Taber, Robert B. President's Address, New England Association..... 278
 Tanks, Construction of Gasholder..... 664
 Taylor, B., How to Manage Steam Engines..... 846
 Technical Education..... 213
 Telegrams of Regret, Ohio Gas Light Association..... 468
 *Test of an Otto Gas Engine, by E. Kidwell and E. R. Keiler.. 208
 *Testing the Gradients of Pipes, Device for..... 212
 Testing Materials..... 663
 *Terrace's Parallel Motion for Gasholder Guiding..... 662
 The Three-Lift Holder at Dowsholm Station, Glasgow Corporation Gas Works..... 427
 *Thompson, Geo. T. Impressions of British Gas Works..... 843
 Thoughts on Electric Units..... 398
 *Three Types of Electric Meters..... 176
 *Thwaite's Gas-Fired Boiler..... 523
 Tinting Incandescent Lamp Bulbs..... 251
 Trewby, Mr., on the Manufacture of Water Gas..... 106

U

Uniform Rates, Graduated vs., by Charles R. Faben, Jr..... 468
 Units, Electrical Thoughts on..... 398
 Useful Memoranda and Information for Engineers..... 705
 Utilization of Residuals from Coke Manufacture..... 104

V

Vagaries of the Electricians, The..... 212
 *Valve Indicator, The Meyer..... 396
 Van Steenberg Water Gas Apparatus, Results from..... 354
 *Vaporization and Feed of Oil to Generator and Retort, by W. R. Addicks..... 556
 Various Methods of Introducing Gas Stoves, by H. A. Norton 322
 Votes of Thanks, Western Gas Association..... 557
 Votes of Thanks, Ohio Gas Light Association..... 916-917

W

*Walker Gas Washer, The..... 211
 *Washer, The Kusnezor Gas..... 42
 Waste of Raw Material in Gas Manufacture..... 627
 Washington's Coal Fields, by W. J. Wood..... 665
 Water Gas, Mr. Trewby on the Manufacture of..... 106
 Water Gas, The Mass. Board of Gas and Electric Light Commissioners on the Subject of..... 245
 Water Gas Apparatus, Van Steenberg's, Results from..... 354
 Water Gas Manufacture, Some Facts Connected with the, by Dr. W. A. Wilkinson..... 587
 Water, the Boiling of is not a Guarantee of Purity..... 885
 *Webb, Prof. J. B., Note on Rankine's Treatment of Chimney Draft..... 171
 Welsbach Company Secures Controlling Interest in Siemens-Lungren Company..... 801
 West, Mr. John A. on Gas and Electricity..... 172
 Why I Shall Make Water Gas, by A. B. Slater..... 320
 Wilkiemeyer, H., Municipal Control of Lighting..... 471
 Wilkinson, Dr., Did He Confine Himself to Facts, by James Somerville..... 695
 Wiring in Boston Buildings, Proposed Legislation in the Matter of Electric..... 3
 Wood, Preservation of by Chemical Means..... 666
 Wood Posts, Their Resistance to Fire..... 774
 Woodward Ralph. Some Notes Taken in a Small Gas Works 355
 World's Fair and the Gas Associations, by Walton Clark.... 838

X Y Z

Yorke, E. H., on Problems Constantly Before the Gas Manager 359

THE AMERICAN

REMOTE STORAGE

GAS LIGHT JOURNAL

REDMAN & KENNY, N.Y.

PUBLISHING OFFICE NO. 42 PINE STREET

DEVOTED TO THE INTERESTS OF ILLUMINATION, VENTILATION, WATER SUPPLY AND DISTRIBUTION, & GENERAL SCIENCE.

VOLUME LIII.—No. 1. }
Whole No. 761.

NEW YORK, MONDAY, JANUARY 6, 1890.

{ \$3 PER ANNUM,
IN ADVANCE.

A. M. CALLENDER & CO., Proprietors. C. E. SANDERSON, Manager.
JOS. R. THOMAS, C. E., Editor. T. J. CUNNINGHAM, Asst. Editor.

ENTERED AT THE POST OFFICE AT NEW YORK, N. Y.
AS SECOND CLASS MATTER.

Published on each Monday of the year, at No. 42 Pine Street, N. Y.

Terms of Subscription, Including Postage.—For the United States and Canada, \$3 per annum. European countries, \$4.50 (19 shillings—22½ francs). All payments to be made in advance. Single copies, 10 cents.

Remittances should be made either by post-office order, registered letter, or bank draft on New York, payable to the order of A. M. Callender & Co.

Correspondence.—Wishing to make this JOURNAL a gazette of intelligent discussion to those of our readers who may wish to gain or give information on the subjects to which its columns are devoted, correspondence is solicited for publication from all who make the study of those subjects a pleasure or a profession.

The American News Company, Nos. 39 and 41 Chambers street, New York, are agents for this JOURNAL. Newsdealers will send orders to them.

Books.—We will forward by express, at publisher's lowest rates, any book—scientific or otherwise—to any address in the United States or Canada. No books will be sent C. O. D.

Collections are invariably made directly from this office, for subscriptions, advertisements, etc. We have agents to solicit the same, but they are not authorized to receipt for money.

CONTENTS.

An Asterisk (*) denotes an illustrated article.

EDITORIALS—

Briefly Told.....	1
The Year's Record—Mayor Noonan Routs the St. Louis Gas Grabbers—The Brownsville (Tenn.) Works to be Rebuilt—Obituary, Arthur W. Benson.	
The Market for Gas Securities.....	2
A Page from Experience with an Exhauster, by F. Egner.....	3
Proposed Legislation in the Matter of Electric Wiring in Boston Buildings.....	3
*Prindle's Retort Lid.....	4
*The Close Gas Manufacturing Apparatus.....	5
Mr. Watson Smith on Naphthaline.....	6
Incandescent Lamps on Buoys.....	7
The Examination of Commercial Glycerine.....	7
Steam Jackets, their Mode of Action and the Reasons of their Economy.....	8
The Dinsmore Process, by Norton H. Humphrys.....	9

ITEMS OF INTEREST FROM VARIOUS LOCALITIES..... 11

Cheaper Gas for Natick, Mass.—Mr. Cosgrove Goes to Atlanta, Ga.—A Presentation to Mr. E. G. Pratt—The Smith Fuel and Illuminating Gas Company—McGuire Wants a Franchise for St. Joseph, Mo.—Progress at Springfield, Mass.—A Hint from Louisville, Ky.—Figures of Sendout from Philadelphia, Pa.—Receiver Appointed—Cheaper Gas for Newton, N.J.—Somerville (N. J.) Public Lighting—Awarded Damages—Reply of President Bull to the Newport (R. I.) Sanitary Protective Association—Incorporated at Rochester, N. Y.—Arc Lighting Tests, Philadelphia, Pa.—Application for an Opposition Charter, Montreal, Canada—Something from Los Angeles, Cal.—Mr. Harbison Got the Candles—And Many Other Items.

Recent Patent Issues..... 13

BRIEFLY TOLD.

THE YEAR'S RECORD.—To American gas men the year just closed will in many respects remain sharply impressed on their memories as one worthy of recollection for the teaching that it conveyed. At the close of 1888 the advocates of the general adoption by gas companies of electrical supply were very glib and positive in their assertions about the necessity of entering on such a course. There was no middle ground upon which they were content to rest—it must be “combination,” or decay. Well, it seems to us at least, from diligent inquiry and an opinion formed from the revelations of such inquiry, that 1889 has acted as an eye-opener to the enthusiasts (self-dubbed, by-the-way) of the thick-and-thin division. In some places the combined plan has been continued with success, in others it has held its own, while in still other situations failure has been the result. In fact the experience of the past twelve-month in this regard all goes to show that local circumstances and influences are the simple factors that are to determine whether or not it is wise for a gas company to undertake the supply of electric currents. We might go a step further and say that as a rule the teaching of the twelve-month is averse to the operation of the dual system, and that this applies to large, populous and wealthy centers is beyond doubt. However, those who are now considering, or in the future will consider the adoption of the dual plan should be in no haste to reach a decision. The policy of watching and waiting is the safe one.

On the other hand, 1889 has also made plain the fact that gas can and does more than hold its own against all opposition. From output figures received from 42 different points in the country, the total sendout (annual) represented is 2,520 million cubic feet, which quantity compared with that sent out from the same places in 1888, exceeds that of the latter year by a percentage equal to 10.6. In none of the places that figured in this respect did the annual sendout exceed 125 millions cubic feet, and in eight of the places reported on the sendout was less than 30 millions cubic feet. The points chosen were representative ones in different sections of the country, and care was taken to exclude from the inquiry locations which were favored by exceptional growth in population or building development. At 12 of the points noted concessions in rates had been made during the year, and, as usual, in these places the increase in sendout was most marked. As the figures were obtained under the condition that the localities would not be disclosed, no further excuse for the “lump” manner in which they are presented is necessary.

But even if they are given in a general statement their teaching is none the less forceful, when it is attempted through their agency to time the pulse of the gas business in respect not to its rugged permanency alone but also to its bounding rate of progress. We submit that the average (10.6 per cent.) of increase is most gratifying; and that it also is beyond what we hoped it would be we are fain to confess. From the general tenor of the replies to our inquiries we are forced to the conclusion that the progress of the gas business in the present year will be at even a greater pace than that maintained in 1889.

This latter conclusion further takes on a decidedly definite shape from our knowledge that many important changes in the line of betterments and new construction are now being considered by the proprietors of several large plants. These will undoubtedly be ordered this spring,

hence the gas works constructors can share to the full in the satisfaction already the portion of the gas proprietors. From a business point of view, then, the old year leaves no unpleasant memories on its history.

Another important development of the twelvemonth was the approach made in the direction of a clearer understanding of the fuel gas problem. We think we are not far wrong in saying that we are now close to the beginning of the end in this respect, and we believe the thanks of the fraternity are due to Gen. Hickenlooper, Geo. Westinghouse, Jr., and Walton Clark for their utterances on this subject during the year. The General, we think, is entitled to great credit for insisting that the *people* have always had fuel gas at their command in the shape of a good article of illuminating gas—it only remaining for the gas maker to supply it at as economical a rate as possible, that his efforts should be intelligently seconded by the manufacturers of gas apparatus, and that the consumer should supplement the efforts of the others by a careful use of the product and appliances placed at his command. Mr. Westinghouse is to be commended most heartily for his manly acknowledgment that the Hickenlooper theory is the one now worthy of acceptance; and Mr. Clark should share in the approval for the admission that while his researches and those of his confreres although not crowned with success as yet, would nevertheless be continued to the end. To sum it up, the conclusions of the gentlemen mentioned point to the same moral—make intelligent use of that which is before you, for such use is but a spur to the perfecting of old systems and in no wise interferes with the search after that which is new.

The dark drapery to the twelvemonth has been adjusted by the hand of death, and that conqueror of man has made his presence sorely felt. In the death of J. O. King, of Jacksonville, Ills., the fraternity suffered a loss that many a day of time will lapse ere its depth be filled. And in it we are led to remark that the Western Association is the greatest sharer. A shining mark, indeed, did death select when the President of the Western Gas Association was stricken down; but time's merciful hand will in due season reconcile them to their loss, and the memory of his good and useful life will after all live with them and us to the end. Others, who bound the present generation of gas men to those of the olden days, to pass away were Philip Deily, of Philadelphia, F. M. Roots, of Connersville, T. A. Cosgrove, of Evanston, Ills., Jas. Wilbraham, of Philadelphia, A. W. Benson, of Brooklyn—but why enumerate them all again? They were with us and have gone before. That is all.

In conclusion, we have but to remark that, for the fraternity as a whole, the dead year was fruitful of material prosperity, and that the skies of 1890 are bright with good promise.

MAYOR NOONAN ROUTS THE ST. LOUIS GAS GRABBERS.—Following up our reference in the last issue to the infamous gas measure proposed in and indorsed by both branches of the municipal government of St. Louis, it is with great pleasure that we publish the fact that Mayor Noonan has refused to give the infamous proposition his official sanction. Not only so, but in a scathing message puts the conspirators in a proper light before the people. It was a sensible act that does much to blot out many of the "inequalities" of the Noonan administration, and was a peculiarly acceptable gift to the people, who were officially informed of the throttling of the measure on the morning of January 1st.

THE BROWNSVILLE (TENN.) WORKS TO BE REBUILT.—Some short time ago the gas works at Brownsville were badly wrecked by explosion and fire, and it was thought by some of the residents that the plant would not be restored. This was not well-founded, however, for Mr. W. B. McKinney, of Troy, O., who owns the plant, has decided to reconstruct the same, and on an enlarged scale. The contracts for the necessary work were awarded about a week ago.

THE new telescopic gasholder (capacity 150,000 cubic feet) at the Alameda (Cal.) gas works, is in satisfactory operation.

WE regret to have to say that Mr. Ralph Woodward, of the Waltham (Mass.) Gas Company, was recently the victim of a painful accident, that obliged him to remain for some days under treatment in the Waltham Hospital. On the evening of December 24th, while engaged in inspecting a service pipe that ran through a dark and littered cellar, he stumbled over a barrel, a rusty nail which protruded therefrom entering his leg at a point just below and to the side of the knee cap.

WE understand that the articles of incorporation, recently filed by Messrs. F. J. Chamberlain, J. H. Smith and W. H. Griffith, at Pueblo, Col., give birth to the Colorado Gas Light and Fuel Company, and that under the certificate the proprietors propose to manufacture water gas in

the Colorado counties of Arapahoe, El Paso, Pueblo, Las Animas, Chaffee, Lake and Pitkin. We understand that the first points to be attacked are Denver and Pueblo. There can be no doubt about the aims of the projectors of this movement, who are evidently intent on raiding invested capital.

OBITUARY.—Arthur W. Benson.—On the 27th of last month, Arthur W. Benson, formerly President of the Brooklyn (N. Y.) Gas Light Company, was stricken by death. As was his life, so was his death. Peaceful and conservative were his habits and manner in the former, in accordance therewith was the latter, the summons reaching him while seated in his boat fishing in the placid waters of Lake Monroe, an indentation of the St. John's river, bordering Enterprise, Florida, where Mr. Benson had been in the habit of evading the rigors of our Northern winter seasons. Deceased was born in Maine, in 1812, removing at an early age, with his parents, to Boston, at which place his education was completed. He finally located in Brooklyn, N. Y., which locality he saw grow from a village of 5,000 inhabitants to its present proportions of a city holding perhaps 800,000 people. He took great pride in improving its condition, and was foremost in urging and assisting that which was calculated to advance its interests. He engaged in the shipping business in New York, and retired therefrom with a competency in 1849, at an age when others as a rule are but beginning to feel safe of their footsteps over the avenues of commerce. About the time that he retired from the shipping business he was elected a member of the Common Council, representing his ward (the First) therein for one term. In the meantime his fortune, by means of wise investment in banking and gas stocks, had largely increased, and many a worthy charity can be traced to his liberal hand. In 1862 Mr. Benson (he had occupied the Vice Presidency of the Company for some years) was chosen President of the Brooklyn Gas Light Company, and remained so until 1882, when he positively declined to be put in re-nomination, or even to allow his name to be balloted for as a director. At this year he withdrew from active participation in business of any sort, but devoted his time to the relief of others. There was perhaps not a better exemplar of real, unostentatious charity in the city of Brooklyn, than the late Arthur W. Benson. For instance, it is matter of record, that his salary as President of the Brooklyn Gas Light Company was annually handed over by him to the Treasury of Grace Church, of which he was a vestryman for many years. His careful and intelligent administration of the affairs of the Brooklyn Company were fruitful of great results, and although he may not be well known to the fraternity of to-day, time was when Arthur W. Benson's name was a household word in the gas ranks of the East. Liberal, broad-minded, charitable, and blunt, deceased was guided by honor, influenced by charity, and controlled by justice in his dealings with his fellow men. The funeral services were celebrated in Grace Church, Brooklyn, on the morning of December 31st.

The Market for Gas Securities.

The market for city gas shares remained fairly even during the week, despite the fact that money was bid up to 12 and even to 15 per cent. Consolidated holds fairly well the advance scored shortly after the declaration of the dividend, and is to-day (noon, Friday) bid for at 92½. Perhaps a resume of the course of these shares on the Exchange during the past year may not be without interest. In the period noted the total sales recorded provided for the transfer of 194,406 shares; the opening price for the year was 82; the highest rate recorded was 94½; the lowest was 80½; the last for the year was 91¾. It is thus seen that the range was 14 points, and that the advance was 9¾ points. The closing price in 1888 was 82. The increase in the dividend rate, from 4 to 5 per cent., during the year, our readers were prepared for, and while a similar move this year would not surprise us in the least, we nevertheless are inclined to the belief that no such step will be taken. We look, however, to see the shares pass the par mark in 1890. And by way of the gossip that is going we might remark that a few days ago we heard a good authority estimate the value of the Company's real estate at 27½ million dollars.

Equitable shares are firm and higher. This Company is doing a good trade. Brooklyn stocks are about as before. Baltimore Consolidated is active and higher, at 48½. This stock looks to us a purchase. The dividend rate of the Hartford (Conn.) Company has been reduced to 3½ per cent. Cornelius Callahan, an owner of stock to the value of \$18,000 in the old Troy Citizens Gas Company, having refused to accept the valuation put upon it by the appraisers who attended to the consolidation of the gas interests of that city, has applied for a commission to revalue the same. J. C. Green, G. W. Greenman and Shepard Tappen have been named as such commission, and they will meet for the purpose indicated on Saturday next. The original valuation was 50 cents on the dollar.

A Page from Experience with an Exhauster.

By FREDERIC EGNER.

Some years ago it was counted a point against the professional character of a gas man if he ventured to express an opinion on any subject connected with the gas business—except, indeed, he did it within the precincts of the Company employing him, and then only to the accredited and constituted authorities, officially, over his particular department. Yet, as the Rev. Mr. Jasper, of Richmond, Va., remarked to his congregation about 12 years ago, "De sun do move, an' I knows it, 'cause de Bible says so;" and I believe we may also say that the world moves, because we see it has done so. And, as evidence of the latter fact, we know that whereas, when silence and secrecy were the peculiar virtues of the gas man, and a yield of 4 cubic feet of poor gas from a pound of good coal, and 4,500 cubic feet of the same gas per retort in 24 hours, was accepted as fairly good average work, that *now*, when we have a number of good associations of gas men, whose members frequently and publicly discuss their business and exchange opinions, 5 cubic feet per pound of coal, and 8,000 to 10,000 cubic feet per mouthpiece, is not at all an uncommon result at many gas works. Further, consumers and gas companies have been benefited by the change from the methods of the dark ages to those of progress and light.

Much more could be done if gas men everywhere would consent occasionally to write up items of their experience for publication in the papers devoted to the science of gas lighting. Doing this would not injure anyone, would make no one poorer—not even the giver of the information—and could not fail to result in good to some. If there be some who, on reading these lines, would say to themselves, "If I told all I know others would be as smart as I am," they might reflect upon the truth that if all teachers of man were inspired with such a spirit humanity would never have gone much beyond the instinct of the beast; and it could be that they themselves were most likely benefited by the published knowledge and experience of others. Possibly they still continue to be so benefited, and are perfectly willing that the benefit should yet accrue. Or, if one should be afraid to be considered as a 'fellow who writes too much,' let him only remember that it is not how much, but *what* he writes, that will win praise or condemnation. And those who still indiscriminately condemn everyone who, for the good of his kind or for his own pleasure, ventures to speak or write, let them carefully note the indisputable results of the old policy of secrecy and silence, and the outcome of the present more enlightened methods mentioned above.

The following experience with an exhauster is neither in the line of high art nor intricate science; it is only one of those everyday occurrences with some of us which, if they were generally made known, would not unlikely save time, trouble, and expense to others without the least injury to anyone.

A few months ago we bought a Number IV. Roots exhauster, intending to use it in connection with our water gas apparatus. When received the machine was in good order, and could be turned easily by hand, together with the engine, which was on the same bedplate. We commenced operations and everything moved smoothly, that state of affairs continuing for several hours, when, without seeming cause, the exhauster began to work irregularly, and at last stopped entirely. Two men could not pull it around, tugging with all their might at the fly-wheel of the engine. We were very angry over having a new machine act in that way, and telegraphed to the factory to at once send an expert to determine what was the matter with the apparatus, as we had not time to look it over, and would not bother with it if we had, because a new machine ought not to start out on its mission in such an eccentric manner—so we thought, and said.

The expert made his examination and gave it as his opinion that that exhauster was built for cold coal gas, and, with the latter, it would work all right, for, see (the exhauster had been opened, wiped out, greased, and was cold then), a child could turn it; and with only 20 pounds of steam and a little opening of the valve the exhauster whirled around with the speed of a buzz-saw, apparently. However, as we wanted the machine to pump very hot water gas, the expert placed a few thicknesses of drawing paper between the cylinder heads and the body of the exhauster, to allow for the extra expansion, but stated that he did not think it would work anyhow. What we wanted to get was one of those hot gas blowers, with water-cooled journals. We did not think so, because we were—and had been for years—using a larger Roots exhauster in our coal gas works. That machine was placed next to the hydraulic main, and was pumping very hot gas—as hot nearly as the Number IV. machine was to work on.

We started again. All worked well for over 24 hours, when the ex-

hauster acted as before. This time we did not send for the expert, for we had seen, when the machine was taken apart before, that it was whole and in good order; so we wanted to find out the real cause of the trouble this time, and remedy it if possible. We found it. On removing the pipe plates we found the heads of the exhauster coated with pitch, and the rollers or pistons were similarly affected. That was the trouble. The machine was well made; it was a close, neat fit everywhere. The thin coating of hard pitch on every portion of the inside of the machine had stopped it as effectively as a number of steel wedges could have done it.

But where did the pitch come from? The oil used in gas making contained none, as we could easily prove by evaporating a quantity of it. The coke used contained none; so where did we get it? Well, here it is. We had used as a lubricant of the exhauster some best, pure, natural, W. Va. 29° lubricating oil. In our coal gas exhauster we use no lubricant at all except on the journals, as the tar coming over with the gas makes this unnecessary; but we had no tar in our water gas, and therefore oiled the cylinder of the machine, through the oil cups on top of it, with the kind of oil mentioned. And that it was which caused the trouble, and in this way: The oil used was, as has been said, a good article of petroleum lubricating oil, which we have used with entire satisfaction on all kinds of engine journals and shafting, and also in a large Roots exhauster at our district station, 3½ miles distant from the works, where we pump, daily, cold gas. But our water gas exhauster had to pump very hot gas, and this gas in its passage picked up all of the lubricating oil except the very heavy portions of it, which were left in the shape of pitch, and this accumulated so slowly and evenly that it was bound to stop the machine at last.

Finding the cause, the remedy was quite simple. We removed the slips of drawing paper, which the expert had put in as previously stated. We cleaned out the machine thoroughly by sweeping, and washing with turpentine; and when we started again we used lard oil as the lubricant, and had no further trouble.

To make very sure of the cause of the exhauster acting as it did, we again tried the "pure, natural, lubricating oil," watching the machine very closely though. In two hours it began to act stiff, and we poured turpentine mixed with a little lard oil into it, whereupon the trouble grew less at once, until it ceased entirely. We continued to oil the machine with lard oil, using it quite sparingly. We have had no trouble with the exhauster since, and, notwithstanding the expert's opinion that it was a cold coal gas exhauster, and would not do for the hot water gas, it has done it, and is doing it right along as nicely as anyone could desire, thus proving that the exhauster was all right in the first place, and showing a cause for defective action which many would not have suspected. But as the remedy is given, and is simple and easy of application, we can now bring this paper to a close, with, it is hoped, satisfaction to the reader as well as to the writer.

Proposed Legislation in the Matter of Electric Wiring in Boston Buildings.

The following report has been made by a sub-committee of "representative citizens," of Boston, Mass., that was formed shortly after the recent disastrous fire in that city. This sub-committee, the report from whom is here appended, was appointed to formulate rules for the proper installation of electric wires in buildings, and the findings handed in are:

Your committee appointed to report upon "Electric Wires Inside of Buildings," would recommend the enactment of laws substantially as follows:

For arc light and power wires, or others designed to carry current of over 250 volts electromotive force.

That they shall not be placed so as to be concealed from view.

That they shall not be allowed in contact with wood or other inflammable building material that may become carbonized, but that they shall be separated from such material by at least ½-inch air space by use of non-combustible, non-carbonizable insulators, placed near enough to prevent contact of the wires by sagging or otherwise, but not further than 6 feet apart.

That with such construction wires of opposite polarity shall not approach each other nearer than 10 inches, except at the lamp and switch.

If the wires are incased in insulating tubing that is impervious to moisture, will not support combustion, and of sufficient mechanical strength to protect them from injury, the tubes may be laid as near as 3 inches to each other, and may be fastened to any building material by use of staples or such other means as will not injure the tubing.

All such wires must enter and leave the building at the same place in

order that a non-combustible hand-switch may be placed outside for the use of shutting off the current.

All insulating covering that will support combustion will not be allowed.

For incandescent light and power wires or others designed to carry currents of less than 250 volts electromotive force.

If such wires are concealed within partitions or like places they must not be allowed in contact with wood or other inflammable building material that may become carbonized, nor with any conducting material such as piping or other wires.

They must be rigidly separated from such material by at least $\frac{1}{2}$ -inch air space by the use of non-combustible, non-carbonizable insulators placed at intervals near enough to prevent contact by sagging of the wires or otherwise.

The wires must be kept at least 6 inches apart, except where they enter junction boxes, cut outs or the like.

Wires laid in plaster, cement or other similar building material will not be allowed, no matter what insulating covering may be used.

In lieu of construction by air space and non-combustible insulators, wires may be incased in insulating tubing that is impervious to moisture, will not support combustion, and of sufficient mechanical strength to protect them from injury, and such tubes may be laid side by side in plaster, cement or similar finish, or in any concealed space where they will not be subjected to injury, and may be supported by staples, or such other means as shall not injure the tubing.

No switch or safety cut out except those made of non-combustible material will be allowed.

For telegraph, telephone, messenger service and all other electric wires not heretofore mentioned, except public fire alarm and police wires and "series" electric light wires.

All such wires in any town or city in this Commonwealth where electric lights or power wires are being operated, must be provided at the entrance of any building (both ingoing and outgoing wires) with some safety device that shall instantly open the circuit or shunt the current out of the building in case the flow of current shall at any time exceed in quantity or electromotive force that which is normally used on such wires.

Such safety device must be located as near as possible to the place where the wires enter the building, and in some place easy of access.

When the safety device is placed inside of the building, the wire connecting it with the outside wire must be of equal or greater carrying capacity.

The device must be mounted on non combustible material.

All switches, cut-outs, insulators, insulation or tubing for use in electric lighting or power work, and all safety devices herein referred to must be approved by the committee or inspector in power before being used.

Prindle's Retort Lid.

On December 10, U. S. Letters Patent (No. 416,855) were granted to F. C. Prindle (of Wilmington, N. C.) for an improvement in retort lids. In the language of the specification the Prindle improvements relate to cylindrical retorts which are provided with doors for admitting raw material and for removing the residual products after heat has been applied to the retorts—as, for example, for the destructive distillation of wood. But the improvements may be applied to hollow cylinders of any sort.

In the accompanying drawings, Fig. 1 is an end elevation of a retort provided with a circular hinged door, and annular parts around its margin corresponding in function and relation to a common door jamb. Fig. 2 is a section on the line 2 2 of Fig. 1. Fig. 3 is a section on the line 3 3 of Fig. 1. Fig. 4 shows an annular end casting to which in practice the door is hinged. Fig. 5 shows an annular casting which constitutes the frame of the improved door. Fig. 6 shows a sheet metal ring to be secured in practice around the periphery of the annular end casting shown in Fig. 4.

Referring to the letters, *A* indicates a section of a hollow, sheet metal cylinder suitable for a retort; *B* an annular end casting having a cylindrical part *B'*, adapted to be secured to the end of the retort cylinder by means of bolts and rivets *C*, for example, passing through the part *B'*, or in any other suitable way. This annular end casting is formed with an inward annular projection *D*, provided with an annular packing socket *E*, for the purpose of receiving a packing ring *F*, which may be of asbestos or any other suitable material. It is also formed with an outward annular projection *D'* adapted to support the end of a retort. It is also formed with an opening or passage (indicated at *G*, and in practice located in the lower part of the casting), for the purpose of

drawing off any residual liquid products that may be contained in the retort. This passage may have applied to it any suitable cock for this purpose.

H indicates a sheet metal ring, which is bolted, as at *I*, or otherwise suitably secured to the outward projection *D'* of the end casting *B*, and serves to rest the retort upon the masonry, so as to leave an air space between the retort and the masonry to facilitate cooling and to prevent overheating the retort in use and injuring it.

K indicates suitable hinge-pivot projections of ordinary character, properly placed or formed upon the outer face of the end casting. The

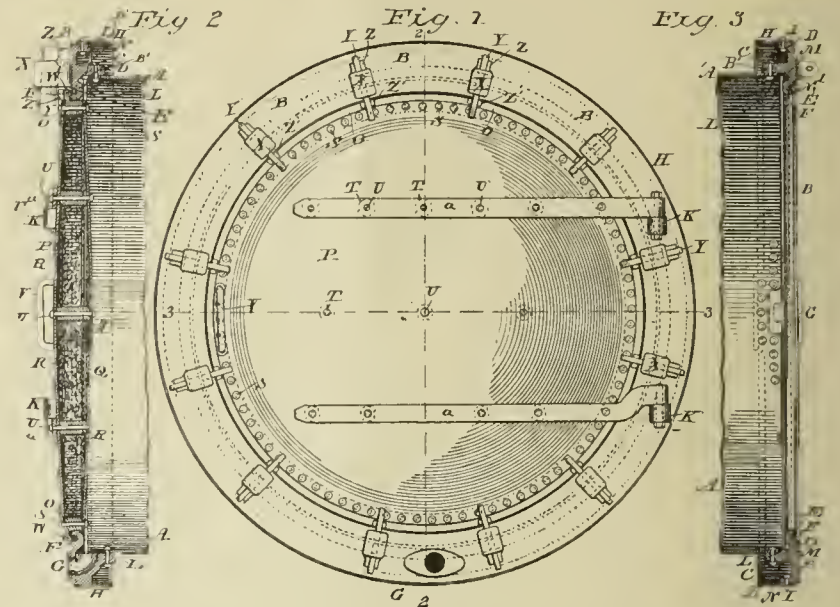

end of the retort cylinder at *L* is preferably cut away so as to incline, as illustrated. A shoulder *M* is formed upon the inner part of the end casting *B*, inclining in an opposite direction to the incline of the end of the retort just mentioned. The object of this structure is to form a dovetail annular pocket for receiving packing *N*, which extends in practice all around the end of the retort and secures a gas-tight joint between it and the end casting.

O indicates an annular casting suitable to form a frame for the retort door and adapted to fit within the end casting *B*. The door is composed of this end casting and an outer sheet metal plate *P* and an inner sheet metal plate *Q* and suitable filling *R* between the two of a character to prevent rapid conduction and radiation of heat from the interior of the retort out to the open air.

Asbestos or some composition of asbestos may be used if desired; but any other substance preferred may also be employed. These inner and

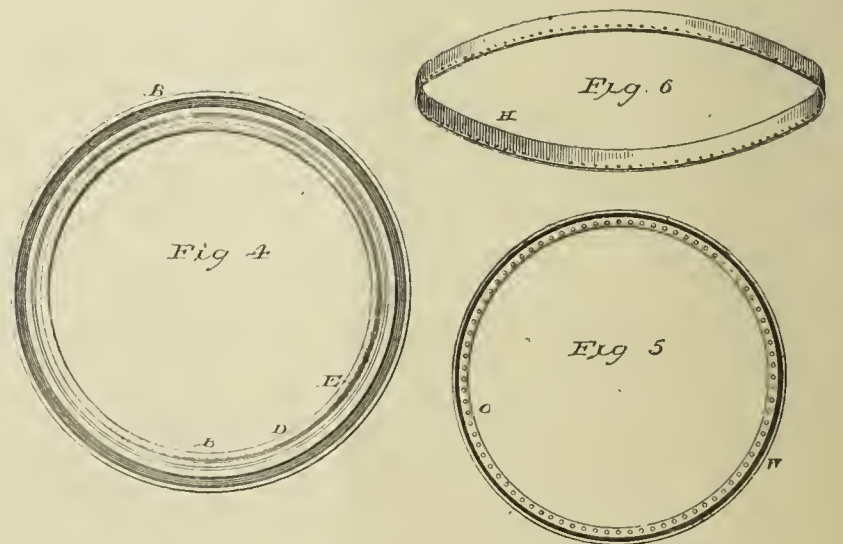

outer door plates consist of concavo-convex metallic discs with their concave faces toward each other and adapted to fit the annular casting *O*, to which they are bolted—as, for example, by means of bolts *S*.

T indicates stay-pieces through which the bolts *U* pass to preserve the contour of the door plates which gives great strength to the door. Any suitable packing may, of course, be used, if desired, between the margins of the plates and the annular casting *O* to make gas-tight joints; but no such packing is illustrated, because it forms no part of the invention and is generally not necessary where the metal work is properly done.

V indicates a handle for the door.

W indicates an outward annular projection from the casting *O* hav-

ing an annular flange *W'*, adapted to fit into the annular socket *E* of the casting *B* and bear upon the packing ring *F* to make a gas-tight joint.

X indicates a series of projections from the end casting *B*, provided with wedge-holes to receive the wedges *Y*. These wedges bear at one end upon stumps *Z* on the end casting *B* and at the other upon stumps *Z'* upon the annular casting *O*, and serve to hold the door in place when closed, as is usual.

a indicates the door hinges, of usual construction.

By the instrumentalities described one is able to form end supports and closers for retorts provided with hinged doors, which are cheap, durable, gas-tight and convenient to use, and that will conserve the heat of retort ends, so as to render the interior of a long retort more uniform in temperature than is usually practicable. By this means he dispenses with clay lutings.

The Close Gas Manufacturing Apparatus.

U. S. Letters Patent (No. 416,825) were granted on December 10th to Mr. Thomas J. Close, of Philadelphia, Pa., who made an assignment of his invention to the Gas Improvement Company, of North America. In his specification the inventor says:

My invention relates to apparatus for the manufacture of gas; and it consists of certain improvements which are fully set forth in the following specification and shown in the accompanying drawings, which form a part thereof.

More particularly my invention relates to externally heated generating

of the retort and the inner compartment or chamber, and are thereby subjected to a large degree of heat, and are superheated and freed of their smoky constituents and made into a thoroughly fixed, pure gas, which escapes to the holder. This inner superheating space between the inner combustion chamber and the outer shell of the retort preferably extends entirely about the inner chamber, so as to form a space on all sides thereof, in order that the products of combustion passing from the inner chamber into this superheating space may be brought in contact with a large area of heating surface. In order to more thoroughly diffuse or scatter the products of combustion throughout this superheating space, I prefer to provide the superheating space with a series of dividing walls or ribs extending longitudinally.

The particular form or shape of the apparatus and the minor details of construction may be varied, as the essence of my invention lies in the formation of a superheating retort with an inner combustion chamber, and a superheating space or spaces between the outer shell of the retort and the inner combustion chamber, through which the products of combustion are caused to pass from the inner combustion chamber to the gas outlet, for the purpose of subjecting them to a large degree of heat to purify and thoroughly fix the gas, and also to protect the inner compartment from an excessive temperature, and thus induce perfect destructive distillation of the products without excessive disintegration and too rapid carbonization of the gas producing materials.

In the drawings, Fig. 1 is a sectional side elevation of the improved retort. Fig. 2 is a cross sectional view of the same upon the line *xx* of Fig. 1. Fig. 3 is a similar view upon the line *yy* of Fig. 1. Fig. 4 is a sectional side elevation illustrating a modification of my invention, and Fig. 5 is a cross sectional view of the same on the line *zz* of Fig. 4.

A is the furnace setting, provided with a grate *B*, above which the generating and superheating retort is supported. *C* is a grate door. *D* is the outer shell of the superheating retort, supported within the setting *A* above the grate *B*. *E* is the gas outlet, opening from the outer shell *D*. *F* is the inner combustion chamber, formed within the outer shell *D* and having a space *G* between the inner surface of the outer shell *D* and the outer surface of the inner chamber *F*. This inner chamber *F* is preferably shorter than the outer shell, and is open at its rear end to the superheating space *G* by a space or passage *H* between its end and the wall of the outer shell *D*, through which products of combustion from the interior of the chamber may escape into the superheating space *G*. This inner chamber *F* is preferably formed with a wall or flange *I* on its rear end to prevent the ashes falling out into the shell *D* and clogging up the lower part of the superheating space *G*. It will thus be seen that the retorts are made long, as compared with their diameter, so as to have as small cubical capacity with relation to the heating surface as is consistent with a proper adaptation to hold the material to be treated.

J is the door of the retort, opening into the inner chamber *F* only, and preferably having an asbestos or other suitable packing *j*, and clamped in place in any manner desired. For the purpose of more perfectly distributing and diffusing the products of combustion throughout the entire superheating space *G*, for the purpose of bringing them into contact with a larger heating area, I prefer to divide the space *G* into channels by a series of longitudinally extending ribs or walls *K K*. These ribs or walls are provided with notches, openings, or holes *k* at the front end to allow the gas to escape to the outlet *E*.

By the arrangement of the ribs the longitudinal passageways are so formed that they communicate with each other at both ends of the retort, receiving the gaseous products at one end and allowing their escape at the other end. The use of these walls or ribs, and the particular formation or construction of them, are not absolutely necessary to my invention, although I consider them an advantage.

In Figs. 4 and 5 is shown a modification of my invention, in which the inner or distillation chamber is formed with a fluted or corrugated surface, with the superheating space *G* formed of the passages made by these longitudinal corrugations. The spaces made by the corrugations open into an annular chamber *g*, communicating with the outlet *E*. In place of making the retort cylindrical, it may be made \square -shape, as shown in dotted lines in Fig. 3, or, in fact, of any form which may be deemed advantageous. The \square -shaped construction referred to would be found advantageous, as presenting a larger surface of the retort directly to the flame of the fuel on the grate *B*.

The operation of my invention is as follows: The door *J* is opened and a suitable quantity of fuel—such as wood or coal—is placed in the inner combustion chamber *F*. The door *J* is now closed and the heat from the furnace dissociates the fuel in the chamber *F* into its gaseous constituents, which escape out of the rear end of the chamber through the passage *H* into the space *G*. Here they are thoroughly subjected to contact with a large area of heating surface, and their smoky constitu-

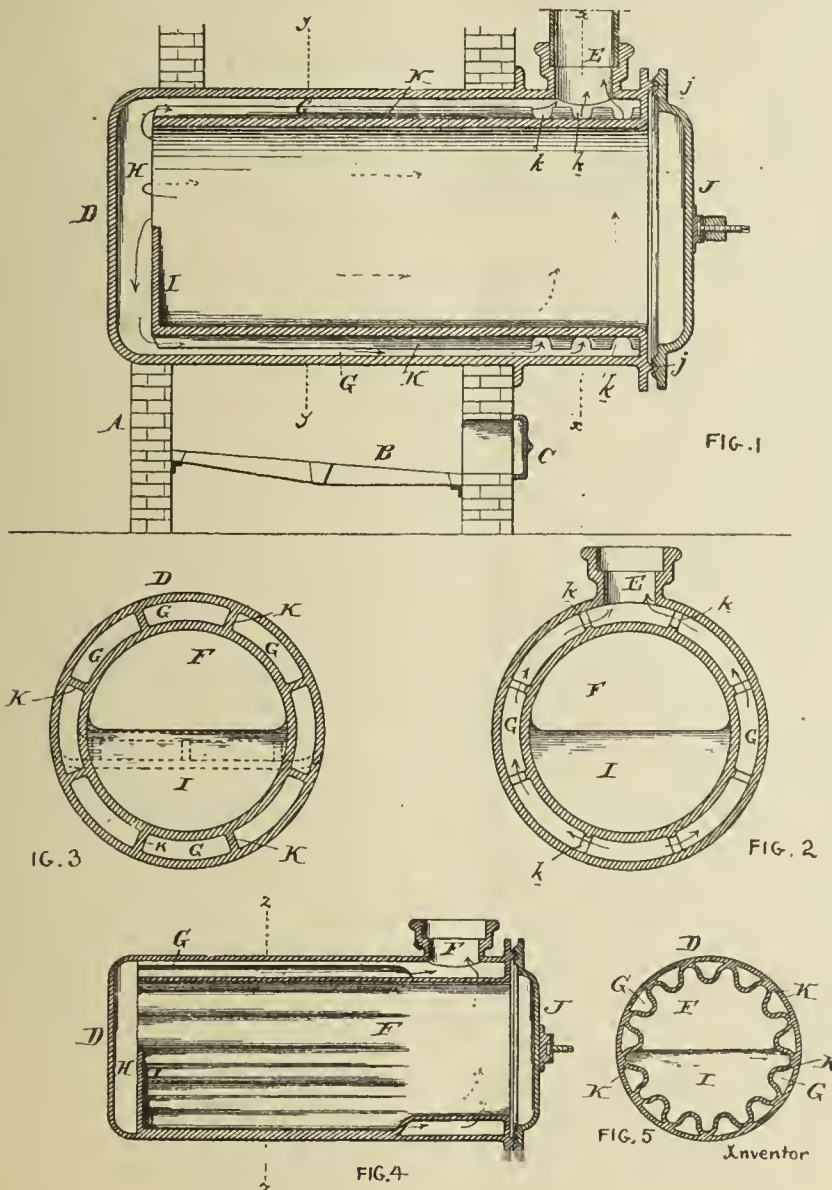

and superheating gas retorts for the purpose of generating and immediately superheating and thoroughly fixing the gas before it passes to the holders, whereby the purity, quantity and illuminating power of the gas is increased.

In carrying out my invention I employ a retort having an inner compartment to contain the gas producing materials, open at both ends, and a superheating space or spaces between the surface of the outer shell of the retort and the inner compartment, a charging door to the inner compartment, and an outlet from the superheating space or spaces to convey the gas to the holder, as more clearly described hereinafter. The products of combustion from this inner compartment pass through the open end thereof into the superheating space or spaces between the outer shell

ents are fully gasified, and a thoroughly fixed gas of excellent quality is produced, which upon reaching the forward end of the superheating space passes through the outlet *E* to the holder without again entering the entrance or throat of the retort. It is evident that in this form of retort the heat of the outer shell is far in excess of that of the inner shell; hence anything which passes in contact with the said outer wall (through the spaces *G*) is going to be heated to a much higher temperature than that of the chamber *F*. This is utilized to superheat the gaseous products emanating from the inner chamber and convert into gases of the proper composition such carbonaceous vapors and gases not already fully dissociated into the required gaseous products, and such gases are then fixed in passing through the chamber *G'*. By performing the superheating and fixing operation in the same structure, and immediately upon the taking place of the destructive distillation of the gas producing materials (wood or coal), I am enabled to obtain a pure gas of high candle power and great non-condensability. The outer chamber *G* also guards the inner wall of the compartment *F* from becoming too hot, and thus interfering with the proper and perfect carrying on of the destructive distillation process.

It is evident that the retort may be made of metal or fireclay, as desired.

In my improvement the inner chamber *F* is permanently in the retort, and is charged with the material to be gasified through the door or cover *J*. The outlet *E* is not exposed by the opening of the retort, as the shell of the inner chamber seals it at the charging end of the retort.

Mr. Watson Smith on Naphthaline.

The London *Journal*, in commenting on a paper read by this gentleman on Monday week, before the London Section of the Society of Chemical Industry, entitled "Some Notes on Variations in the Products of Different Gas Coals Heated Separately in the same Retort and under Similar Conditions," says considerable attention was devoted to the subject of naphthaline deposits.* Mr. Smith did not appear to be aware that this subject is now interesting to gas engineers in a theoretical sense only, as the causes which lead to its formation are fairly well understood, and also the remedies that are necessary to prevent it; and it seems like going back some 20 or 30 years to find advice given as to the means to be adopted for preventing naphthaline. Briefly, it may be stated that since gas engineers have become alive to the necessity for proper and gradual condensation as distinct from a mere cooling of the gas, they are not troubled with naphthaline to such an extent as to render them anxious to hear of a remedy. With many it has disappeared altogether, and with the remainder an occasional service or main stoppage—usually attributable to the specially exposed position of the pipe in question—represents the sum total of their naphthaline experience. It may then be asked: "If this is so why has the subject of naphthaline any interest at all, even in a theoretical sense?" and the answer is simply that its illuminating value is very high. It is well known that when returned to the gas, in the form of "albo-carbon," a great improvement in the illuminating value is effected. The experiments made by Mr. Leicester Greville showed that 1 pound of naphthaline is equal in illuminating value to 17 pounds of sperm. The view that producers of artificial light should take of the question is not so much an uncompromising removal of such a valuable illuminating constituent from the gas, on account of its inconvenient proclivity to precipitate in the solid form, but a consideration of how it can be retained in the gas and delivered at the burner of the consumer. It is in this light that we approach the consideration of Mr. Smith's paper.

The various hypotheses which are to be found at the commencement may be briefly passed over as the consideration of a chemist rather than those of a practical gas engineer. As to the fact of "air and sun dried coal" receiving a more drastic carbonization than coal "in the usual condition of dampness," we may remark that the percentage of hygroscopic moisture in gas coal as ordinarily carbonized is too low to have any great effect on the temperature of carbonization. Any reduction in temperature sufficient to prevent or materially hinder the formation of naphthaline would also have an effect on the more important result of "make of gas per ton." It is well known that working at high temperatures causes the production of naphthaline; but this is only true within certain limits. With the introduction of generator furnaces the tendency has been to increase the carbonizing temperatures. Higher heats and quicker charges are the order of the day. But no evidence is forthcoming to show that any increased production of naphthaline is observable. The fact that the presence of light hydrocarbons—such as benzene

—in the gas is effective in retaining naphthaline and preventing its deposition was observed many years ago, and hence the old-fashioned practice of sweeping out the mains with charges of cannel gas, or of sprinkling the oxide in the purifiers with naphtha.

The likening of naphthaline to snow was a simile adopted by Mr. Lewis Thompson, in a letter to the *Journal*, 33 years ago; and in this connection Mr. Smith seems to have got into some confusion as to the existence of slow currents in the gas mains in summer and stronger ones in winter. The comparatively small consumption during the summer is not so much due to slower currents as to longer hours of daylight. In many districts there is a close agreement between the proportionate consumption of gas and the hours of darkness before 10 P.M. Thus, when there are only two hours (from 8 to 10 P.M.) the consumption will be about one-third of that experienced when there are six hours (from 4 to 10 P.M.). Therefore it does not appear probable that a stream of gas is likely to rush through the pipes at any time during the winter with sufficient force to stir up scales of naphthaline that have laid motionless during the summer. Many gas engineers agree in observing that trouble from naphthaline is experienced at times of changeable atmospheric temperature—such as warm days and cold nights; but we do not find that any have connected them with the velocity of travel in the gas mains. Further, if this theory is correct, the naphthaline should appear in the busiest districts, and at the services of the largest consumers, whereas the exact reverse is the case. The deposits are particularly liable to favor "blind" pipes, lamp services, and other localities where the current is slow. It may be well to observe that some gas engineers use naphthaline as a generic term for deposits of any kind from the gas in the supply pipes. But it frequently happens that the deposit is of a tarry nature, especially where rich gases are supplied, and in cold weather the stoppage may simply be due to freezing of moisture present in the gas.

Mr. Smith has conducted a series of experiments upon seventeen varieties of coal, representing the principal or typical cannel and gas producing coals in the northern coal fields of England. The results were given in a table, and they comprise yield and quality of gas, quantity and strength of liquor, quantity and specific gravity of tar; also percentage of naphthaline and number of gallons of light oil distilling below 180°, and light oil above 180°, per ton of tar. These results are greatly robbed of their interest by the fact that the author is so careful to conceal the names of the coals as not even to state if they are cannel or otherwise. This is, however, perfectly clear from the quality of the gas made. In the majority of cases the make is high—10,200 to nearly 11,000 cubic feet per ton—and the quality rather low—about 14½ or 15 candles. In six instances there is a comparatively small yield of high-quality gas, ranging from 24 to 29 candles. Mr. Smith does not appear to have directed his attention to the quantity of naphthaline present in the gas—a point on which gas engineers are especially desirous of information. The general impression is that the bulk of it does not escape condensation, and that the actual proportion present in the gas as supplied to the consumers is extremely minute. Many chemists have searched for it by means of the usual tests, and failed to find it; and have even been led to suggest that it is formed by synthesis under the conditions which lead to its deposition in the pipes. So we may take Mr. Smith's results as practically indicating the total quantity of naphthaline formed. The only connection to be traced between the proportion of naphthaline and the yield or quality of gas is that the high percentages appear to favor a large make. This may be due to the fact that the percentage of naphthaline agrees remarkably well with the specific gravity of the tar; and a high make of gas is usually accompanied with a yield of thick, heavy tar. The proportion of naphthaline ranges from 2.15 to 6 per cent. In the highest case there is a yield of about 7½ lbs. per ton of coal, equivalent to more than 120 lbs. of sperm, or somewhere about 25 per cent. of the total illuminating value represented by the yield of the gas. With the cannel this proportion is considerably less, and of course the total sperm value is higher; so that the value represented by the naphthaline is represented by less than one-tenth of the whole. Even at the lower rate, however, it is impossible to avoid an expression of regret that such a valuable illuminant should be allowed to go into the tar well. The general conclusion is that a coal which yields the lightest tar is the least likely to cause trouble with naphthaline. In other words, the coal should furnish a sufficient quantity of light oils to be capable of absorbing or scrubbing the naphthaline out of the gas. If these light oils are reduced from any cause, as by working at an abnormally high temperature, then the naphthaline is less likely to be removed, and therefore more likely to be carried on with the gas. So we are in the anomalous position that a sufficient quantity of one illuminant—viz., light oils, which have been shown by

* See JOURNAL, Dec. 20, 1889, p. 923.

Mr. Liecester Greville to possess an illuminating value nearly equal to that of benzene, or about 12 times that of sperm—should be left in the tar in order to secure the removal of another illuminant—viz., naphthaline. The manufacture of illuminating gas as at present conducted is therefore open to the charge of wastefulness; as it is an unavoidable feature that considerable quantities of illuminating matter must be allowed to pass into the tar well. Mr. Smith's advice, in effect, is either to use a coal that produces a sufficient excess of light oils to render the tar thin, or else to so carbonize it as to secure that result. It sounds more like the advice of a tar distiller than of a gas engineer.

The real question for manufacturers of illuminating gas to consider is not how much naphthaline they produce, but how to secure its complete removal, or better still, how to retain it in the gas. The quality of tar produced does not affect them so long as the tar remains fluid enough to flow off into the tar well. It may contain either 2 or 6 per cent. of naphthaline for all they know—the price received for it will probably be the same. Their point is to secure the highest possible illuminating value in the form of gas; and to prevent annoyance to themselves and their customers on account of stopped pipes. Possibly the circumstances which favor the formation of naphthaline may be just those which yield the best results from their point of view. If the proportion present—be it 2 or 6 per cent.—cannot be retained in the gas without being liable to deposit on the slightest provocation, then the question of means for its removal that will at the same time be thoroughly efficient, and as innocuous as possible in regard to other illuminating constituents, comes into view. Many practical men regard naphthaline in gas as present in the vaporous form, and therefore subject to the laws which influence the carrying of vapors by gases, as continually instanced by water vapor in the atmosphere. There is a "saturation point" beyond which any excess of naphthaline present would be deposited in the solid form; and this point varies according to the conditions of temperature and pressure. Assuming this to be correct, it follows that if the gas is reduced at the works to the lowest temperature to which it is likely to be exposed in the course of its subsequent existence, no further trouble from deposits will be experienced, as any excess of naphthaline present in the gas will be thrown down then and there. This vapor theory is substantiated by the careful experiments of M. Bremond, which do not appear to have attracted Mr. Smith's attention. M. Bremond found that the desiccation of the gas, by passing it through dry lime, was in practice a cure for any tendency to deposit naphthaline. This was explained by the statement that removing one vapor from the gas would leave it more free to retain another.

Mr. Smith's paper comes with singular aptitude immediately after the discussion of the Dinsmore process, at the recent meeting of the Manchester District Institution of Gas Engineers. Mr. Carr shows that it is possible to obtain higher illuminating value from the coal than that which is secured under the usual system of carbonization. Mr. Smith shows that a margin for such increased value exists. We have only to suppose that the conditions obtaining in the Dinsmore duct are favorable to the decomposition of naphthaline, with the formation of lighter hydrocarbons, in order to afford an explanation of the increased value claimed for the Dinsmore process.

It is well known that naphthaline is perfectly stable at the temperatures prevailing in the Dinsmore duct; but that is no reason why it should not be amenable to the influences of other hydrocarbons also present with it. The fact that the production varies in a wide ratio—from one to three, that is very much in excess of other results, such as quantity or quality of gas, or quantity and specific gravity of tar—indicates either that the circumstances which lead to its production are of a narrow character, confined within small limits of temperature; or else that, when formed, it is very liable to decomposition. So it is to be hoped that the further researches on the Dinsmore process, which Mr. Carr indicates as likely to be made, will include an examination of the resulting tar for naphthaline.

Incandescent Lamps on Buoys.

A recent report, made by Captain Millis, of the United States Light-house Board, in relation to the electric lighted buoys at the Gedney's Channel entrance to New York Harbor, states that a year's service shows that the system is a practical success. During the last nine months over 220 ocean vessels passed through the channel between sunset and sunrise. The buoys withstood the heavy storms of last September without drifting from their positions, and not more than two lamps out of six were extinguished at any one time. On one occasion a buoy was run down by a vessel and entirely submerged without

injury. Some trouble has been experienced from moisture getting through the lamp sockets and destroying the connections, but a new form of lamp has been devised which promises to be free from this objection. It has been found that the life of lamps made with red glass globes was much shorter than that of the uncolored ones, an effect which was attributed to the interception of a greater portion of the heat radiated from the carbon filament; and lamps with bulbs of clear glass are now used on all the buoys, lanterns lined with red glass being used to produce the red lights. Captain Millis notes the fact that a building on shore, very near the buoys, was twice struck by lightning while the buoys and their connecting cables were uninjured, and adds: "It is probable that the use of an earth return insures greater safety from damage by lightning than it would obtain if the circuits were entirely insulated."

The Examination of Commercial Glycerine.

Mr. J. H. Wainwright, F.C.S., of the New York branch of the U. S. Laboratory, has prepared the following valuable paper on this subject, which ought to be of great assistance to the gas chemist, if not the gas engineer. He remarks:

The tariff law of 1883 imposes upon "Glycerine, crude, brown or yellow, of the specific gravity of one and twenty-five hundredths or less at a temperature of 60° Fahrenheit, not purified by distilling or refining," a duty of two cents per pound; and upon "glycerine, refined," a duty of five cents per pound.

In view of possible attempts to enter, through the Custom House, a partially refined glycerine as the crude article, a sample of every importation of so-called crude glycerine is submitted to the U. S. Laboratory for examination as to whether it is properly invoiced, or is partially or wholly refined; in the latter case it should pay the higher rate of duty. It has been always considered by the chemists at this port that the extent of "refining" properly permissible in a glycerine in order to bring it within the definition of *crude*, is the allowing of impurities to subside by long standing, or removing them by a process of straining or filtering, and all samples showing evidence of having been treated further than this are reported as *refined* and subjected to the higher rate of duty.

For purposes of classification under the tariff law referred to above, *distillation* has always been regarded as the dividing line between crude and refined, and efforts have therefore been made to determine by means of physical and chemical tests whether this process of refining has been employed, since nearly all the glycerine imported as crude is bought by distillers for the manufacture of glycerine to be used in making dynamite (for which purpose distilled glycerine alone is used) and the white C. P. article used for medicinal and pharmaceutical purposes.

I will now call attention to some of the characteristics of crude and refined glycerine. Glycerine, crude, is defined by the tariff (T. I. new, A. 4) to be "brown or yellow, of the specific gravity of one and twenty-five hundredths, or less, at a temperature of 60° Fahrenheit, not purified by refining or distilling." Crude glycerine is the product obtained directly by stearine candle manufacturers from the saponification or disintegration of their fats and oils, and is a by-product in the manufacture of soap, being obtained from the waste lyes.

Its specific gravity is usually 1.25, or less, at 60° F., but the gravity of waste lye glycerines sometimes runs much higher, owing to the large amounts of chlorides, etc., present.

Its color is yellow, brown or black, but never white, sometimes light yellow, usually medium to dark yellow and often dark brown or black.

It possesses a strong characteristic odor of fatty acids, usually disagreeable, sometimes even foetid.

Reaction to litmus paper may be either acid or alkaline, never neutral.

Refined glycerine is usually the product of the distillation of the crude article, the distillation being repeated several times and the resulting glycerine concentrated and further purified by decolorization, etc., according to the uses for which it is intended. Its gravity is usually about 1.25.

Its color ranges all the way from dark brown or even black to white, according to the extent to which the process of distilling or refining has been carried.

If distilled it should have either no odor at all or a more or less burnt odor. This odor in a *distilled* glycerine is highly characteristic and suggests the odor obtained on burning gunpowder. If refined without distillation, as would be shown by other tests, the odor of fatty acids, if any, should be very faint. Distilled glycerine also possesses a characteristic taste faintly suggestive of garlic. This taste, however as well as the burnt odor, is only exhibited in distilled glycerine of inferior quality.

Reaction neutral or very faintly acid.

In determining the nature of a sample of glycerine a problem is often met with, inasmuch as it is often a matter of great doubt whether a sample has been distilled or not. The following tests, however, I regard as extremely reliable, and, with experience and practice, they afford results which admit of very nice distinction between crude and refined (or distilled) glycerine.

A 10 grm. sample is heated in a tarred platinum capsule until it inflames, the source of heat is removed and it is allowed to burn spontaneously; the residue is then weighed and its per cent. calculated. Distilled or refined glycerine will yield from 0. to 0.5 per cent. of "carbonaceous residue," rarely more than 0.5 and never as much as 1 per cent. (unless in the case of an otherwise apparently high grade article it has been adulterated, which would be shown by other tests), whereas crude glycerine yields as high as 10 per cent. I have found the per cent. of "carbonaceous residue" as determined by this test to admit of duplication within very narrow limits.

If desired, a determination of the ash may be made by igniting the "carbonaceous residue."

According to Sulman and Berry (Analyst, 11, 12) the determination of the ash will definitely decide whether the glycerine is crude or distilled; this is somewhat of an error, as it does not necessarily follow that a small proportion of ash alone would indicate that the glycerine had been distilled, since a large proportion of the glycerine manufactured is made directly from fats by "saponification" with steam, in which case the impurities would necessarily be organic and would be destroyed in the process of incineration, hence, other tests to show the presence of fatty impurities must be employed.

I have frequently found samples yielding as high as three per cent. of "carbonaceous residue" and less than 0.05 per cent. of ash. The proportion of mineral matter, however, affords a good indication of the character of the sample, since, in refined glycerine, the ash is never higher than 0.2 per cent. and rarely as high as 0.1, whereas, in crude glycerine made from soaps, lyes and other processes of saponification, the ash frequently runs as high as 14 per cent.

If deemed desirable, an examination of the ash may be made; this also will often afford an indication of the source of manufacture from which the glycerine was obtained (Allen's Com. Org. Anal., 2d ed., 2, 297). Of all the other tests which are recommended for the examination of glycerine the two most important are those made with solutions of silver nitrate and basic lead acetate in distilled water, the former being a two per cent. solution and the latter being made by adding 10 grams, of C.P. lead acetate and 8 grammes of litharge to 500 c. c. distilled water, boiling for some time and filtering. The tests are made as follows:

The silver nitrate test.—Dissolve 5 c. c. of the sample to 20 c. c. distilled water in a large test tube and add 5 c. c. silver solution, shake, allow to stand at rest for one hour. In refined glycerine a darkening of the solution may occur, with even a slight reduction of silver, after standing some time; it will be quite heavy if allowed to stand long enough, even in highly refined samples, but if it is not quite heavy at the end of one hour the result may safely be considered an indication of refined glycerine. In crude glycerine a considerable precipitation takes place, usually at once, and is nearly always *flocculent*. The precipitate may be of any color from black to white, according to the nature of the impurities present.

The lead test.—This test is made by adding to the lead solution in a large test tube, its own volume of a solution containing equal volumes of the sample and distilled water, and shaking and allowing to stand at rest for one hour, as in the silver test. Refined glycerine will remain unchanged or will show a slight precipitation or cloudiness, but never a *flocculent* precipitate, even on standing for a long time, whilst in crude glycerine there will always be more or less of a *flocculent* precipitate.

In applying these tests it is *never* safe to rely on either of them *alone*, as it will frequently happen that a sample will be met with which will stand one test and not the other; however, if it will not stand both of these tests it is perfectly safe to call it crude, and, with some experience, a fair idea of the value of the sample may be obtained. By boiling, the tests may be greatly hastened, although this is not recommended except in extremely doubtful cases, as the test thereby becomes much more delicate.

If deemed desirable other tests may be made, and among them the following will be found useful.

The addition of an equal volume of distilled water. Refined glycerine will remain clear. In crude glycerine if much oil or fat be present they may be separated from the glycerine in this manner:

Ammonia.—Refined, no change; *crude*, precipitate indicates presence of iron and alumina.

Ammonium Oxalate.—Refined, no change; *crude*, precipitate indicates lime salts.

Barium Chloride.—Refined, no change; *crude*, precipitate indicates sulphates.

Nitrogen Peroxide (Gas).—Refined, no change; *crude*, curdling indicates fatty impurities

Fehling's Solution.—Refined, no change; *crude*, shows the presence of glucose, etc.

For other tests recommended for the examination I would refer to the very able paper of Messrs. Sulman and Berry (Analyst, 11, 12 and 34), and to Allen's Com. Org. Anal. (2d ed., vol 2, 292 et seq.).

With a fair amount of experience a discrimination between crude or raw and refined or distilled glycerine will readily be accomplished by means of the foregoing tests, and, moreover, a fair idea as to the quality of the sample may be obtained, and it may be ascertained beyond a doubt whether it is fit for the manufacture of nitro-glycerine for which so much of the refined glycerine of commerce is used.

Steam Jackets, Their Mode of Action, and the Reasons of Their Economy.

Prof. Dwelshauvers Dery, of Liege University, writing in *Engineering*, says:

In the second volume of M. Hirn's book on the "Mechanical Theory of Heat" (Paris, 1876), the author devotes the first pages to the study, based on actual experiments, of the action of steam jackets. He compares two experiments made under practically the same conditions, with this single difference, that the steam jacket was not at work in the first, but was used in the second. It will, we think, be of practical utility to engineers, if we endeavor to give a brief summary of his analysis and conclusions.

Firstly, we give in the following Table the results of experiments in fractions of the total heat brought by the steam into the cylinder:

	Fractions of Total Heat brought by Steam into Cylinder.	
	Without Steam Jacket.	With Steam Jacket.
Heat given to the walls by partial condensation during the admission of steam—called(R_a)	0.459	0.380
Heat returned from the walls to the steam during expansion(R_d)	0.173	0.317
Heat passing from the walls to the condenser by evaporation during exhaust.....(R_e)	0.273	0.050
Heat lost by external radiation.....(E)	0.013	0.013
Heat furnished to the steam from the jacket.....	0.022
Heat equivalent to external work performed during expansion.....(T_d)	0.088	0.113

The heat given up to the walls by the steam during admission is afterwards (1) utilized during expansion to increase the external work; (2) wasted during exhaust in evaporating the water remaining in the cylinder, and sending it on to the condenser; (3) wasted in heating the surrounding atmosphere. We get therefore:

$$0.459 = 0.173 + 0.273 + 0.013$$

$$0.380 = 0.317 + 0.050 + 0.013$$

We see from this Table, first, that the jacket considerably diminishes the initial condensation, that is the heat given up by the steam to the walls during admission, since this is represented by 0.459 without the jacket, and only by 0.380 with it; secondly, the jacket increases the external work during expansion, the heat equivalent to this work being 0.088 without the jacket, and 0.113 with the jacket, in other words an increase of 28.4 per cent. If this increase is expressed as a fraction of the total heat expended, it will be 0.025.

Hitherto the action of the jacket has been considered merely as transmitting to the steam working in the cylinder a quantity of heat represented by 0.022. Even this small amount of heat has produced very great results. But the influence of the jacket does not stop there. We find that it actually reverses the proportions of the gains and losses of the heat stored up in the metal during admission. To prove this, let us compare the heat utilized during expansion and the heat lost during exhaust with the heat due to initial condensation, taking the latter as the unit of heat. We find the following figures:

$\frac{0.173}{0.459} = 0.378$	$\frac{0.317}{0.380} = 0.834$
$\frac{0.273}{0.059} = 0.596$	$\frac{0.050}{0.380} = 0.132$

	Without Steam Jacket.	With Steam Jacket.
Heat usefully employed during expansion.	0.378	0.834
Heat lost from the walls during exhaust by the cold condenser.....	0.596	0.132

Thus, without the jacket the heat stored up in the metal walls during admission can only benefit the work of expansion to the extent of 0.378. With the jacket the gain is 0.834. Without the jacket the loss in heat passing unutilized into the condenser is 0.596, while with the jacket this loss is reduced to 0.132. Here are the facts; we will now sum them up in a few words.

The steam jacket has transmitted 0.022 of heat through the metal walls, and this heat has been completely absorbed and utilized during expansion. But its action does not stop there. It has diminished the quantity of heat given up by the steam to the metal during admission by $0.459 - 0.380 = 0.079$; and as a consequence the wasteful cooling of the metal during exhaust has decreased by $0.273 - 0.050 = 0.223$, and the profitable cooling of the metal during expansion has increased by $0.317 - 0.173 = 0.144$. The physical explanation of these phenomena is given by M. Hirn, and he also adduces other facts no less worthy of attentive consideration. We will try to summarize these as clearly as possible.

The interior wall of a steam cylinder passes through successive phases of high and low temperature, in consequence of its contact with mixed steam and water, the pressure of which varies continually. There is a continual exchange of heat going on between the metal and the steam, sometimes in one direction, sometimes in another. For the fluid in action in the cylinder is not homogeneous; water and steam are not mixed in the same proportions in the center and in the neighborhood of the walls. Of course the interchange of heat only occurs in the strata in contact with the walls, for heat does not easily penetrate a gaseous body. The process of transformation from a liquid to a gaseous state, or the reverse, which is produced by this exchange of heat, certainly does not take place, because the entire mass has received or lost heat, but only the particles in contact with the walls. If at the same time the whole temperature happens to vary, this is in consequence of a change of pressure, occasioned by partial condensation or evaporation. In short, it is not a propagation of heat from one particle to another through the whole body of steam which is here meant, but a local exchange of heat in a limited portion, produced by direct contact with the walls, which condenses or evaporates the saturated steam or water. The first is always a slow process: the latter, because of the unstable equilibrium of these bodies, is extremely rapid.

During admission the steam in condensing heats the metal walls, and gives up to them R_a thermal units. This heat the metal returns to the steam; firstly, during expansion, R_d ; secondly, as wasted heat during exhaust, R_e . If we neglect the external radiation, we have

$$R_a = R_d + R_e.$$

Any method which tends to diminish R_a or to increase R_d at the expense of R_e is economical. The jacket and superheated steam, therefore, both produce a saving. The effect of the action of the jacket is to keep the metal walls at a higher temperature, and thus to diminish R_a ; but it also increases R_d by evaporating during expansion the greater part of the water which covers the inner surface of the metal. The result of this is useful, because the residue of water which is lost in evaporation during exhaust is diminished. But the steam in the jacket is far from furnishing all the heat necessary for evaporation. It only acts as an auxiliary to the steam condensed during admission.

The heat given by the jacket to the cylinder during exhaust has, so to speak, no influence, except, perhaps, to shorten the time necessary to evaporate the water adhering to the internal walls of the cylinder at the beginning of exhaust. At this moment there is a certain weight of water in the cylinder, and a certain amount of heat will be required to evaporate it, which will be neither more nor less, whether there is a jacket or not. The water once evaporated, any further heat the metal can transmit through the gaseous body is insignificant.

If the effect of the jacket were to evaporate all the water condensed during admission, just at the moment when this evaporation would be most useful, that is, during expansion, the loss through the influence of the walls would be reduced to external radiation only, that is, to its minimum. And the result would be obtained with very small expenditure of steam in the jacket.

Hitherto we have only spoken of single cylinder engines. Experiments have proved that a radical difference exists between the thermal

phenomena presented by a non-jacketed engine, according to whether it has one or two cylinders. In a compound engine the expanding steam is, in fact, almost entirely separated at each stroke of the piston from the steam flowing in from the boiler. Therefore the effect of the walls upon it must also be different. In a single cylinder non-jacketed engine the metal walls give up heat to the steam during expansion, although the quantity of heat surrendered is much less than with a jacket. In a compound engine, on the contrary, the walls, even during expansion, absorb heat from the steam and lose it during exhaust.

If the jacket be applied to a single cylinder, it gives little heat, although the effect produced is very great. For the larger part of the heat given up by the walls, and employed in useful work during expansion, is that already imparted by the steam to the metal during admission. In a compound engine, on the other hand, it is the heat given up by the steam in the jacket which increases the work performed during expansion. M. Hirn says: "With such striking differences caused by details of construction apparently almost insignificant, we are led to believe that a given engine, with a single cylinder and without a jacket, probably may, in consequence of some small structural difference, utilize the heat given up to the walls during admission better than some other engine. Far from being impossible, it is in fact quite likely that the proportion between the work of expansion, for instance, and the exhaust cooling may depend partly upon the relation existing between the diameter of a cylinder and the stroke, or the proportion between the total volume of the cylinder to that of the steam during admission."

One more word concerning superheating, which was employed with remarkable economical effect for thirty years by M. Hirn at Logelbach, and which deserves the closer attention of engineers. This is perhaps the most efficacious means of counteracting the injurious effect of the cool walls upon the hotter steam. It is the best way of increasing the work during expansion by diminishing the exhaust cooling and the initial condensation, because the steam thus contains in itself the heat necessary for these different operations. Of course, neither the advantage obtained by employing superheated steam, nor that afforded by the steam jacket, can be exactly represented numerically. Those who have read the foregoing remarks will easily understand that it depends upon the preliminary conditions under which the engine is already working with saturated steam.

The Dinsmore Process.

[Contributed by Mr. Norton H. Humphrys to the London Journal.]

The paper on this subject, which was read by Mr. Isaac Carr at the recent meeting of the Manchester District Institution of Gas Engineers, presents several features that are interesting in a theoretical, as well as in a practical sense. The importance of an increased yield to the extent of 10 per cent., with an increase of 20 per cent. or so in quality, is obvious, especially considered in connection with the comparatively simple arrangement that, according to Mr. Carr, is sufficient to secure such results.

The apparatus described in the paper is certainly a great improvement on that originally proposed, and is the more worthy of attentive consideration as being the outcome of experiments on a working scale. If any valuable illuminants are to be extracted from the tar, by exposure of the same to the influence of heat, this can only be done while the tar is in a state of vapor. And therefore it must be more reasonable to deal with the crude gas fresh from the retort, than to condense the tar out of the gas, and subsequently revaporize it. But Mr. Carr runs full tilt against the established practice in gas engineering. The general rule is to insist on the importance of getting the gas away from the retort as soon as possible. Any appliance that assists to this end—such as the exhauster or the anti-dip valve—is usually said to increase both the yield and the quality of the gas. Claims of this nature have been advanced over and over again, and it is a curious fact that Mr. Carr should obtain similar advantages by going to work in an opposite direction. Instead of hurrying his gas away from the high temperature of the retort, he gives it a prolonged contact therewith. An important feature in connection with the subject is that the Dinsmore process appears to be an anti-dip process—i. e., the gas passes straight away from the duct to the foul main, without meeting any equivalent to the ordinary hydraulic seal. It should further be stated that, according to the opinions general amongst gas engineers, the effect of passing crude gas through a hot retort, is simply a depreciation of quality, attended with a deposition of carbon.

The plain description given in the paper enables one readily to calculate the progress of affairs in the empty retort, or duct, as it is called. The production from six retorts passes through it, and a fairly regular

composition is secured by charging the retorts respectively at regular hourly intervals. So we may say that both the quantity and quality of the gases passing through the duct are practically regular from hour to hour. According to Professor Foster's report, the daily make per bench is 32,500 cubic feet; so that the quantity passed per hour is 1,350 cubic feet, or 22.5 cubic feet per minute. This quantity is, speaking roughly, about equal to 1.33 of the capacity of the duct, so we may say that each particle of the gas is exposed to the heat mentioned—a bright cherry red, cooled down at the outlet to a dull red—for about 45 seconds. The effect of this heating, as usually stated, would be an increase in the proportion of free hydrogen and marsh gas, with a corresponding loss of illuminants. But according to both Mr. Carr's experience and Mr. Foster's report, this does not represent the facts. A sample of pure Dinsmore gas made on November 11, contained, amongst other constituents, 6.76 per cent. of hydrocarbons, 40.34 per cent. of marsh gas, and 43.98 per cent. of hydrogen. A sample of the town gas, made on the same day, contained 4.37 per cent. of hydrocarbons, 33.39 per cent. of marsh gas, and 50.6 per cent. of hydrogen. This town gas consisted of a mixture of one part Dinsmore gas to two of ordinary gas, made by the usual process; and it therefore follows that the "ordinary" gas contained not much more than 3 per cent. of hydrocarbons, about 30 per cent. of marsh gas, and about 54 per cent. of free hydrogen. But the hydrocarbons in the ordinary gas are of a very different character to those in the Dinsmore gas. In the town gas we have a carbon density of about 3.7, and a hydrogen density of 6.3: as compared with 2.9 and 5.8 respectively in the Dinsmore gas. The effect of the lesser carbon density in the hydrocarbons shows itself in a marked manner in the specific gravity of the Dinsmore gas, which ranges from .420 to .440, merely a trifle more than that of the "ordinary" gas. But it must be remembered that the Dinsmore gas is freed from carbonic acid, whilst the town gas contains 2 per cent. of that impurity. Gas of 22-candle power made by the ordinary process is usually found to have a specific gravity of .530 to .550; and no explanation of the comparative lightness of the "Dinsmore" gas is apparent from the analysis. It may be remarked that, according to published analyses, the carbon density in the hydrocarbons rarely exceeds 3; so the illuminants in the Dinsmore gas do not present any special feature in the matter of carbon density, as compared with ordinary gas. The hydrogen density being about twice that of the carbon, indicates a composition corresponding to that of the olefines (C_nH_{2n}); but this result might also be made up by a mixture of paraffines (C_nH_{2n+2}) with acetylene (C_2H_2). The extreme lightness of the gas, which is the more noticeable when we observe that it contains 8 per cent. of carbonic oxide—which is a comparatively high proportion—precludes the presence of almost all hydrocarbons other than ethylene, acetylene, and perhaps ethane. Benzene vapor is nearly three times, and naphthalene more than four times as heavy as air.

It is generally supposed that the heavy hydrocarbons in coal gas are principally made up of bodies of the paraffine and olefine series. The hydrocarbons in coal tar are stated to comprise heavier members of these classes—also benzenes, naphthalenes, acetylenes, and crotonylenes, or pseudo acetylenes—besides small quantities of several other classes. If we examine the results likely to obtain by passing a mixture of these bodies, largely diluted with hydrogen and marsh gas, through the "ducts" as given in chemical text books, we shall find that—

1. The higher members of the paraffine classes may be decomposed into lower members of the same class, and small proportions of other hydrocarbons, together with a proportion of free hydrogen.
2. The olefines may be decomposed into bodies of the acetylene class and free hydrogen. At a full red heat they may be converted into paraffine, with a separation of carbon in the solid state.
3. Benzenes may be converted into acetylenes with separation of free hydrogen and various secondary products.
4. Naphthalenes and acetylenes are not likely to be affected to any practicable extent.

Apart from these reactions, which are all of an analytical or "breaking up" character, there may be some of a synthetical or "building together" character, such as the union of carbon and hydrogen to form acetylene, etc.

It has already been observed that the reactions obtaining in the duct are attended with the formation of hydrocarbons of comparatively low specific gravity—i. e., the lower members of the various hydrocarbon series; and it further appears that they are attended with the deposition of but little solid carbon. It may be suggested whether the temperature of distillation in the Dinsmore bench is not lower than that usually practiced. We are told that the duct, which is situated in the hottest part of the setting, should not exceed 1,800°; and the charges used—2

cwt. in the bottom retort, and 2½ cwt. in the others—are rather light, considering they remain in for six hours. The analysis of the Dinsmore gas is very similar to that which might be expected to obtain from rich gases made by working at moderately low temperatures in the ordinary way, except that under such circumstances the proportion of free hydrogen is usually lower. But there is the circumstance that the yield of gas is increased 10 per cent. or so, which must be borne in mind when making comparisons between the *percentage* of hydrogen and marsh gas present in the Dinsmore, as compared with the ordinary gas. The same bulk of hydrogen—viz., 5,400 cubic feet—that would represent 54 cent. on a make of 10,000 cubic feet of gas per ton, would only represent 49 per cent. on a make of 11,000 feet. This increase of bulk cannot be due to decomposition of heavy hydrocarbons resulting in the formation of marsh gas and hydrogen. The increase of the former is especially marked, as it amounts (after allowing for the increase in bulk as above noticed) to nearly 15 per cent., or more than enough to account for the larger yield secured by this process.

But the analysis and the illuminating value of the gas, show that while the heat of the duct undoubtedly exercises a negative action, so far as illuminating power is concerned, by decomposing hydrocarbons with the result of increasing the bulk of the gas—a thing that cannot be done without some loss of illuminating value, since the resulting products are certainly of lower value, and indeed may have no lighting power whatever—there are also reactions of a positive character, whereby substances that under ordinary circumstances would be deposited with the tar, are converted into others that are retained in the gas, and are possessed of high illuminating value. The positive reactions are more than sufficient to balance the negative ones; and therefore the net result of the whole is an increased percentage of hydrocarbons, and an increase of illuminating power. This advantage is secured at the expense of some 30 per cent. of the tar; and the increased bulk is much greater than that which might be expected to follow the decomposition of the hydrocarbons that under ordinary circumstances would remain in the gas as such. The greater part of it must be credited to substances that usually remain in the tar.

It is to be hoped that the inquiry undertaken by Professor Foster will be further extended to include a comparison of the heavy hydrocarbons existing in the "Dinsmore" gas, with those obtained in the usual way. Until some further information on this head is available, it is not possible to speculate with any safety as to which of the reactions above named are of most importance, or prevail to the greatest extent. But from the fact that Mr. Carr moderates the heat obtaining in the duct by cooling (if one may use the expression) the back part, it appears that the gases are just exposed to the heat for a sufficient time to ensure their being raised nearly to the maximum temperature obtaining in the duct, but are not allowed any prolonged exposure to this temperature. They are, so to speak, toasted but not allowed to scorch. If this point is not observed, we learn that there is some danger of deterioration in the quality of the gas, together with separation of solid carbon. In the course of conversation with Mr. Carr, I learnt that the same result would follow if the stream of gas through the duct was diminished from any cause—such, for instance, as one or more of the retorts not being in use. Under normal working, the separation of solid carbon is inconsiderable; and therefore it appears that Mr. Carr favors the class of reactions that result in the separation of free hydrogen—such, for example, as that concerned in the formation of acetylene.

Not only does the Dinsmore process practically do away with the hydraulic seal, by relegating it to the subordinate position of a safety bye-pass, but it also deals with another vexed question—viz., that of stopped ascension pipes. A plain ascension pipe, we are told, used as the outlet from the duct, would block up solid in a few hours' time; but the use of a water jacket, into which water runs at the ordinary, and escapes at a boiling temperature, prevents this trouble. The water jacket simply acts as a cooler; and the gas escaping from the duct must certainly receive a rapid reduction in temperature. How this should enable the crude gas to carry off tarry matters, that would be deposited with such rapidity in a warmer pipe as to block it up in a few hours, is one of those obscure points that will perhaps be cleared up when we arrive at a clear understanding as to the cause of stopped ascension-pipes. Even with water jackets of insufficient capacity, Mr. Carr found that the deposition of pitchy matter was greatly accelerated, thus affording further support to the supposition that the tarry deposit is prevented by simply cooling the pipe to a proper degree.

The actions obtained in a Dinsmore duct appear to be similar to those that occur in the superheater of a water gas apparatus of the Lowe type. In the one we have a mixture of hydrogen, marsh gas, and carbonic oxide, carrying a small proportion of illuminants, and loaded with

tarry vapors; and in the other a mixture of hydrogen and carbonic oxide, loaded with heavy hydrocarbonaceous vapors given off by the partial vaporizing and partial gasifying of the petroleum that is admitted at the upper part of the cupola. The fact that the Dinsmore duct converts some 30 per cent. of the tar into permanent gas, gives some indication of the value of the superheater as a "fixing" agent, especially when it is remembered that the former is empty, whereas the latter is usually packed with firebrick.

ITEMS OF INTEREST FROM VARIOUS LOCALITIES.

WE are in receipt of a very pleasant reminder from Mr. Geo. F. MacMun, Superintendent of the Natick (Mass.) Gas Light Company, that his Company is still in the field, and proposes to remain so, as a dispenser of cheap and good gas. That the hold of that corporation on the goodwill of the residents may be still further tightened, we have only to remark that on the first inst. the proprietors authorized their Superintendent to announce that the gross rate for gas is to rule at \$2 per 1,000 cubic feet, prompt payment to secure to the ordinary user a rebate of 10 cents per 1,000, while all those whose monthly consumption amounted to 10,000 cubic feet and over are granted a rebate of 20 cents per M. This means cheap gas for Natick, and also proves that the management of the Company is abreast of the times.

WE understand that Mr. W. L. Cosgrove, of Evanston, Ills., has been appointed Secretary of the Atlanta (Ga.) Gas Light Company, which is now being operated by the United Gas Improvement Company. We wish Mr. Cosgrove every possible success in his new field.

WE are indebted to an occasional correspondent for the following account of something that happened, on December 24, at Des Moines, Iowa: "Manager E. G. Pratt, of the Capital City Lighting Company, was yesterday afternoon made the recipient of a handsome surprise, the employees presenting him with a gold watch with the initials 'E. G. P.' on the exterior of the case, while the inside cover bore the inscription, 'Presented to Mr. E. G. Pratt, Christmas, 1889, by the employees of the Capital City Gas Light Company, and of the Thomson-Houston Electric Light Company.' The presentation took place in the afternoon. Mr. Pratt, accompanied by Mrs. Pratt, reinforced or flanked by a wagon load of turkeys, had gone to the works of the Company on the east side of town, and after the fowl had been distributed the men did not seem in any hurry to move off. The cause of their loitering was about like this. The assignment of the turkeys having been completed, Mr. M. T. Wright, Secretary of the Company, stepped forward and thanked Mr. Pratt on behalf of the men, and then introduced Mr. Keffer, who he (Secretary Wright) was inclined to believe wished to say a few words to the Manager. Mr. Keffer then spoke as follows: 'Mr. Pratt—I have been delegated by the employees of the several light companies under your management, the most of whom surround you at this time, to address a few words to you, from a business and social standpoint, touching somewhat upon the history of the Companies. The Capital City Gas Light Company was organized and commenced business in this city in 1876, and for the first ten years of its existence was under the management of Mr. W. A. Agard, who as a manager made it one of, if not the most popular, corporations in the city. It was a Company with which the business men of the city were pleased to do business, and every patron of the Company was its friend. In due course of time the Company sold out and became a part of the great system of the United Gas Improvement Company, of Philadelphia, and Mr. Agard, having business interests elsewhere, resigned his position. The home Company, in casting about for a suitable successor to Mr. Agard, made what seems to us a wise selection in choosing you. And you came among us to assume the duties of the position about three years ago. Your whole life had thus far been spent near your boyhood home, and from which you had never ventured very far away. It required, it seems to us, a good deal of nerve for a man who has had the honor to have been born and reared so near to the center of the earth—Boston—to determine to come to what to you must have been in your imagination the wild and woolly West. But possessing a good supply of nerve, which has been shown, and we suppose backed up by a fair salary, you made the venture; and you found the West not wild at all, and I do not think you have yet seen any evidences of wool. Be assured, Mr. Pratt, that we are not trying to pull the wool over your eyes on this occasion. Upon taking charge of affairs it became your duty, first, to set the machine in motion according to the plans of the new Company. This we all know required a great deal of hard study and harder work. You were ably

assisted, however, by your former co-laborer, hard worker, and always a gentleman, Mr. W. A. McEwen, our efficient Secretary, to whom we all reluctantly said good-bye only a short time ago. It then became your duty to look out for your charge from a business standpoint, and that you have succeeded admirably in all your undertakings is evident on every hand. When you came to us we had a gas works—a good gas works—and a small arc light plant. To-day, thanks to your efficient management, we have a gas works the peer of any in the Northwest, and an electric plant second to none. Our pipes and lines have been extended in every direction. The reputation and good name of the Company have been kept up to their former high standard, and it is to-day a model institution of its class. We realize that to you must and should be given great credit, too, for the success thus far attained by the Company; and yet is said that 'things don't happen.' When we consider the fact that you commenced this business in an humble position, similar to that now occupied by our friend Mr. Rivers, as a cleaner of lamps, and that step by step you have progressed until coming to your present high place, we are not surprised, for it is only the legitimate outcome of knowing what to do, how to do, and when to do. We come together to-day, Mr. Pratt, from the different departments of this great plant, a great crowd of men, every one of whom earns his bread by the sweat of his brow, and whose dearest action is on the field of labor, your friends, and to give honor to whom honor is due. It has been from time immemorial the custom upon occasions such as this, when employees, recognizing the ability and services of their manager or superintendent, in addition to their congratulations, to leave something of a more enduring character than the words they may speak, and taking advantage of this occasion, on this Christmas eve, they have requested me, as one of their number, to present you with this souvenir of the day, something at once useful and beautiful. We ask you to accept it with our best wishes, and expressing the hope that our relations, which have ever been so pleasant in the past, may continue, and that even greater success may attend your efforts in the future, and that you and your estimable wife—without whom your success might not have been—may have a very merry Christmas and a right happy New Year.' To say that Manager Pratt was surprised is to put it very mildly indeed, and he ought to be extremely thankful that no merciless stenographer was on the platform, with clever symbol and unerring pencil, to transcribe his incoherent speech of thanks, which, however, was none the less agreeable to his hearers, even if it lacked somewhat in rhythm. The occasion was a most enjoyable one, and Manager Pratt will remember it for many a day."

WE regret to announce the death of Mr. A. W. Benson, formerly President of the Brooklyn (N. Y.) Gas Light Company.

THE Decatur (Ills.) Gas Company's electric annex seems to be in high favor with the residents of that city. If we mistake not, the Company is under contract to furnish not less than 1,200 incandescent lights, of 16 candle power each.

THE Smith Fuel and Illuminating Gas Company has been incorporated in Michigan, with a capital stock of \$600,000. The Company proposes to operate under patents granted to Ambrose G. Smith, of Sheboygan, Wis. A part of the scheme is to sell "State rights" for the operation of the Smith type of apparatus; and we would advise those approached under this head to look into this thing pretty closely.

ADVICES from St. Joseph, Mo., are to the effect that Chas. McGuire, of that city, has applied to the Council for an ordinance to operate a fuel gas works. This ordinance differs from the Crosby application (which, as was reported in the JOURNAL, had been laid on the table by the Council, with the understanding that it would remain there for some time) in that McGuire agrees to furnish light, heat and power from his gas to the City Hall, city prison and fire engine houses, without charge. He also agrees that his Company shall have three miles of mains laid by Aug. 1, 1890, that length to be increased to ten miles within 18 months from the date of the franchise, at which time the gas is to be ready for distribution on a large scale. It is also stipulated that the price to be charged for illuminating gas shall not exceed \$1 per 1,000, the rate for a heating gas supply to be 75 cents per 1,000. From our present knowledge of this last application to the Council we believe that it is not made in good faith; further, that St. Joseph can get along very well without McGuire's proposed gas company.

THE Springfield (Mass.) Gas Company has over 500 gas stoves on its services, 40 per cent. of which were placed in 1889. We might also note that the cutting off of the public lamps (the public lighting is now

almost entirely performed by means of electricity), which represented a shrinkage of something like 3½ million cubic feet per annum in the send-out, has not diminished the total output for the year. This speaks well for Mr. Hallett's determination to keep in front, and shows that his confidence in establishing a large increase in the Company's day trade was well founded.

It is more than probable that the Louisville (Ky.) Gas Company will make a trial on a fairly large scale of the Gordon burner for street illumination. The send-out of the Company for the year shows a large increase—in fact, we should not be surprised to hear that the maximum send-out (daily) approached closely to 2½ million cubic feet. Engineer Barret's new holder ought to be a source of great consolation (and safety) to him these dark days.

THE following figures show the quantities of gas sent out from the Philadelphia works on the dates mentioned—the quantities are in millions of cubic feet:

Year.	Dec. 24.	Dec. 25.	Dec. 26.
1880.....	9,115	7,251	6,416
1881.....	9,746	6,746	7,350
*1882.....	7,496	7,766	9,740
1883.....	11,624	8,436	9,723
1884.....	11,268	8,665	10,205
1885.....	12,674	9,070	10,839
1886.....	13,973	10,524	9,474
1887.....	13,415	9,479	11,075
1888.....	14,454	10,784	12,933
1889.....	13,360	10,094	12,470

THE new Company at Duquoin, Ills., is almost ready to supply gas. The public lamps (100 in number) have been placed in position.

MR. LYNN R. ZIMMERMAN, of Rochester, N. Y., has been appointed receiver of the Medina (N. Y.) Gas Light Company, a receivership having become necessary because of the verdict of damages awarded Wm. Allport, who sued to recover for injuries occasioned by an explosion at the works some months since.

THE following notice has been published by the proprietors of the Newton (N. J.) Gas Light Company: "Nearly four years ago the Newton Gas Light Company reduced the price of gas from \$4 to \$3 per 1,000. We take pleasure in announcing a further reduction—the concession to take effect on all gas consumed from Dec. 1: In quantities of less than 5,000 feet per month, \$3 per 1,000; in quantities of 5,000 feet or over per month, \$2.50 per 1,000. From these prices a discount of 10 per cent. will be allowed on all bills paid within 30 days, making the net prices \$2.70 and \$2.25. If the Company meets with sufficient encouragement, it hopes to be able to make a still further reduction in the future." This is the practice that pays.

SOME days ago the proprietors of the Somerville (N. J.) Electric Light Company made a proposition to the authorities for the public lighting that was based on very reasonable terms. The Gas Company, however, also submitted a bid that was finally accepted by the Town Commissioners, and a contract executed under it. The rate agreed on was \$1.50 per lamp (a total of 70 posts to be maintained) per month, the lighting to be kept up every night and all night. No wonder the Town Commissioners acted as they did.

IN the case of H. A. Keyser vs. the Mahanoy City (Pa.) Gas Company, tried at Pottsville in the last week of December, a verdict for \$3,000 was awarded the plaintiff. The latter is a hotel keeper, and the basis of his complaint was that his business had been ruined by the offensive odors emanating from defendant's plant. The case will be appealed.

IN our last issue we published an account of certain action by the Newport (R. I.) Sanitary Protective Association in respect to the proposed supply of a mixture of coal and water gas by the Newport Gas Light Company. It may be remembered that a portion of that action was the appointment of the President of the Association as a committee to interview the President of the Gas Company on the exact nature of the gas that was to be supplied by the Company. The inquiry was made, and the reply thereto of Mr. Henry Bull, President of the Company, is as follows:

*Sunday.

"OFFICE NEWPORT GAS LT. COMPANY, }
"NEWPORT, Dec. 24, 1889. }

"Dear Sir: I have your note asking to be informed what percentage of water gas our Company proposes to use as an ingredient of the illuminating gas of this city; and in reply would say. Our primary object in having a water gas plant is to provide additional security against our city being left in the darkness from any serious accident to our works, or from sickness, death or defection of skilled workmen, whose places could not readily be filled. Not that we are specially liable to such contingencies, for our works are second to none of their size in the country, and are provided with every safeguard known in the manufacture and distribution of gas. The additional advantage of a small water gas plant is that it can be fitted up at once to supplement the gas in our holders, on the first indication that the supply is likely to be short. Our secondary object in having a water gas plant is to determine by our own experiments the feasibility of supplying mixed gases, which it is now generally claimed will produce, at the same cost, better light than either kind alone. We are led to do this from the fact that there are now in the United States 367 water gas plants in use, furnishing that gas either as an entirety, or as an ingredient of coal gas, all of which have sprung into use in 14 years. In this State, Woonsocket has put in one recently, and the city of Providence is now erecting one with a capacity of 800,000 cu. ft. daily. In regard to the relative poisonous influence of the two gases, the opinion now prevails among those best informed on the subject, that there is little or no difference between them in this respect, and that neither is deleterious to the public health except through ignorance or carelessness in their use. From these explanations you will see that I cannot now give you a categorical reply to your questions, but in order to allay all apprehensions which your Society may entertain for the safety of gas consumers, I assure you that under no circumstances will this Company send out any gas whose presence in the atmosphere to the extent of 8 per cent. is rapidly fatal to life through its de oxygenating action on the red blood corpuscles, as well as its specific effect on the central nervous system. I am very truly yours, HENRY BULL, President."

THE "City Gas Company, Rochester, N. Y.," has been incorporated by James A. Chapin and Ed. T. Rice, Jr., of New York City, and Samuel Walters, of Jersey City, N. J. Its term of life is put at 50 years, and it is capitalized in \$500,000. Although the avowed objects of the Company "are to manufacture and sell gas, electricity, and other agents for the production of light, heat and power," it is not at present surmised that the project is intended to compete with the artificial gas company of Rochester. It probably had its inception in the recent howl raised against the natural gas suppliers in upper New York for their increased gas rates, and most likely has to do with the supply of the natural article.

IN future the contracts for public lighting by means of arc lamps in Philadelphia are to be based upon the intensity, etc., of the current furnished, instead of on the present estimate of candle power.

IT is presumed that this determination arose from the fact that recent tests for candle power made on arc lamps furnished under contract to the city of Philadelphia proved the illuminating value to be greatly under that bargained for by the city. For instance, the Thomson-Houston lamps (2,000-candle power nominal) had an average value of 1,160 candles, the Brush record being 936 candles. The United States Company's lamps (1,000-candle power nominal) yielded but 479 candles.

THE Newark (N. J.) Gas Company has declared a quarterly dividend of 2½ per cent.

THE Pottstown (Pa.) Gas and Water Company has declared a stock dividend of 25 per cent. The Company will build a new water plant this year.

ABOUT a fortnight ago Senator Butler again introduced the bill offered by him at the last session of the United States Senate to incorporate the Equitable Gas Light and Fuel Company of the District of Columbia. The incorporators named are Messrs. Chas L. Mitchell, Jacob Bertschman, W. A. De Long, Harry Keene, C. D. Harrison, Frederick W. Jones and E. W. Saportas. Capitalized in \$2,000,000.

THE Newton and Watertown (Mass.) Gas Light Company is engaged in experimenting with an electric system for lighting and extinguishing the public lamps.

THE Dover (N. H.) Gas Light Company, having been appointed local agent for the sale of the Welsbach incandescent gas burner, has fitted

up its offices on Portland street with an extensive assortment of the various sizes of the burner noted.

APPLICATION has been made to the Provincial Legislature by certain promoters for a charter for a company to be known as the Montreal Consumers Gas Company. The capital stock is placed at \$3,000,000, with power to increase the same to \$6,000,000. It is understood that English capitalists are behind the scheme. The charter of the present Montreal Gas Company does not expire until 1895, and under its provisions the Company is obliged to make a considerable concession in gas rates, the same to take effect in May of this year.

A SINGULAR accident occurred in the laboratory room of the Lawrence (Mass.) gas works one day last week. Messrs. H. H. Church, of the gas works, C. W. Stevens of the Wright Manufacturing Company, and G. S. Stevens, of the Atlantic Mills, were examining the various chemical apparatus in the laboratory when a bottle containing ammonia burst, the liquid causing severe burns to two of the party.

It is said that an opposition gas enterprise has been organized for Owego, N. Y., the plant for which is to be located on the site of the old flour mills, in what is known as the Canawanna district. The Company is to be known as the Citizens Gas Company, and its Directors are: Messrs. W. E. Dorwin, W. L. Haskins, C. O. Thompson, E. T. Stone, W. E. Mayor, D. W. Pitcher and Geo. F. Andrews, of Owego, and Geo. F. Lyons and W. G. Phelps, of Binghamton.

THE bids for the lighting of Boston by means of arc lamps have been rejected, and new specifications have been arranged for.

A RECENT issue of the Los Angeles (Cal.) *Tribune* contained the following: "The Los Angeles Lighting Company has purchased the plant of the Lowe Gas Company, and this transfer of property has led to complications likely to be settled in the courts. It is said the new company refuses to recognize the contracts entered into by its predecessor, and claims the right to fix its rates irrespective of any agreement entered into by the Lowe Gas Company. In pursuance of this policy a collector of the Company called on H. J. A. Stuhr, a wholesale liquor dealer on West First street, and presented a bill at the usual rates. This Mr. Stuhr said he did not feel compelled to pay, as by the terms of an unexpired contract with the Lowe Gas Company he has heretofore received a rebate payable in shares of the company. A day or two thereafter a plumber called at Stuhr's warehouse, saying that he had come from the Los Angeles Lighting Company to remove the meter. Stuhr objected to this summary method of settling the dispute and ordered the plumber from the premises. Going at once to the police station the plumber laid the case before the department, and an officer was detailed to protect him from harm. Reinforced by an additional helper from the Company's office the three repaired to Mr. Stuhr's store, No papers nor authority of any kind were shown by the officer, except his star, which Mr. Stuhr said he regarded as scarcely sufficient in the replevin of property or the violation of a contract for lighting his premises. He submitted, however, upon pain of arrest, to the removal of the meter, but will institute suit to determine what right the Company had to act in the manner described."

THE Queen City Electric Light Company, of Dallas, Texas, is engaged on the construction of its central station.

It is reported that the Board of Trustees of Saratoga Springs, N. Y., have granted a franchise for the operation of an opposition gas and electric light plant in that place. The capital stock of the new concern is put at \$100,000, and as the capital of the old Company is \$300,000, the Trustees, by their injudicious action, have placed the gas consumers under obligation to pay interest on an additional 33 per cent. of capital investment. Now is the time for cheering over opposition, but the result is sure to furnish a season of howling about consolidation.

SHORTLY before Christmas the Hartford *Daily Times* notified the residents that "Gift No. 5" on its Christmas tree consisted of a box of wax candles, which were intended for the Gas Company, "to help it out on dark nights." Taking the "funny man" at his word, Mr. Harbison visited the *Times* office on Christmas morning and demanded that "Gift No. 5" be given him. He got the candles.

THE water gas plant for the Hutchinson (Kas.) Gas Light and Fuel Company will soon be in working order.

GAS was turned into the mains of the new gas works at Aberdeen, South Dakota, on the evening of December 20th. Supt. Gray is to be

congratulated on the celerity with which construction work was pushed at this point.

THE rumor is current in Pittsburgh that the Philadelphia (natural gas) Company is shortly to put a new contract schedule in force that will show a large increase over the rates for 1889.

Recent Patent Issues.

The following list of recent patents relating to the gas interests is specially reported by Franklin H. Hough, solicitor of American and foreign patents, 925 F street, N. W., Washington, D. C.

ISSUE OF DECEMBER 3, 1889.

- 416,520. Gas, Apparatus for Manufacturing of. R. R. Turner, Columbus, O.
- 416,609. Gas Apparatus, Oil. A. Henning, Oakland, Cal.
- 416,624. Gas Burner for Incandescent Illumination. A. C. Humphreys, Philadelphia, Pa.
- 416,649. Gas Engine. C. Sintz, Springfield, O.
- 416,216. Gas Governor. F. Ellis, San Francisco, Cal.
- 416,635. Gas Lighting System. A. Lungren, New York, N. Y.

- ISSUE OF DECEMBER 10, 1889.

- 416,776. Apparatus for Mixing Gas and Air. E. B. Denny, Newark, N. J.
- 416,825. Apparatus for Manufacturing Gas. T. J. Close, Philadelphia, Pa.
- 416,986. Gas Burner, Coal Oil. L. J. W. Bairn, Chicago, Ills.
- 417,101. Gas Burner, Safety Attachment. M. Siersdorfer, Louisville, Ky.
- 416,979. Gas Burner, Safety Attachment. R. P. Williams, Boise City, Idaho.
- 416,707. Gas Burner, Self-Lighting. E. S. Allen, New York, N. Y.
- 416,753. Gas Furnace, Regenerative. C. M. Ryder, New York, N. Y.
- 416,722. Gas Governor and Pressure Regulator. N. J. Ryder, Washington, D. C.
- 416,895. Gas Light Safety Catch. J. D. Bowman, Altoona, Pa.
- 417,075. Gas Lighter, Electric. N. Newman, Springfield, Ills.
- 417,198. Gas Lighter, Electric. N. Newman, Springfield, Ills.
- 417,134, 417,135 and 417,136. Gas Pressure Regulators. H. J. Bell, Gloucester City, N. J.

ISSUE OF DECEMBER 17, 1889.

- 417,431. Gas, Apparatus for Manufacturing of. J. Schinneller, Pittsburgh, Pa.
- 417,526. Gas Burner, Incandescent. J. L. Stewart, Philadelphia, Pa.
- 417,471. Gas Engine. W. E. Crist, Brooklyn, N. Y.
- 417,472. Gas Engine Igniter. W. E. Crist, Brooklyn, N. Y.
- 417,624. Gas Engines, Operating. J. C. Beckfield, Allegheny, Pa.
- 417,658. Gas for Heating and Illuminating Purposes, Apparatus for Manufacturing of. B. T. Babbitt, New York, N. Y.

ISSUE OF DECEMBER 24, 1889.

- 418,016. Gas, Apparatus for Manufacturing Illuminating and Heating. J. Hanlon, New York, N. Y.
- 418,018. Gas, Apparatus for Manufacturing of. J. Hanlon, New York, N. Y.
- 418,017. Gas, Apparatus for Manufacturing of Illuminating. J. Hanlon, New York, N. Y.
- 417,719. Gas Burner, Automatic Safety. N. M. Garland, St. Louis, Mo.
- 417,765. Gas Burner, Open. G. E. Wright, Birmingham, England.
- 417,924. Gas Engines, Automatic Ignition in. E. Korting, Hanover, Prussia.

ISSUE OF DECEMBER 31, 1889.

- 418,270. Gas and Electric Light Fixture Combined. D. J. Braun, Chicago, Ills.
- 418,550. Apparatus for Manufacture of Gas. M. C. Burt, Lake View, Ills.
- 418,615. Apparatus for the Manufacture of Gas. J. Hanlon, New York, N. Y.
- 418,647, 418,648, and 418,649. Apparatus for Manufacture of Gas. P. W. McKensie, New York, N. Y.
- 418,551. Apparatus for Manufacture of Gas by Electricity. M. C. Burt, Lake View, Ills.
- 418,417, 418,418, and 418,419. Gas Engine Igniter. L. H. Nash, South Norwalk, Conn.
- 418,314. Gas Retort Furnace, Regenerative. W. Foulis, Glasgow, Scotland.



A. M. CALLENDER & CO.,

PROPRIETORS.

EDITOR—Jos. R. Thomas, C.E.

ASST. EDITOR—T. J. Cunningham.

MANAGER—C. E. Sanderson.

PUBLISHED ON EACH MONDAY OF THE YEAR AT

No. 42 Pine Street, New York.

This is a recognized official organ of LIGHT, HEAT, STEAM, WATER SUPPLY, VENTILATION, SANITARY IMPROVEMENT, AND GENERAL SCIENCE

TERMS:

SUBSCRIPTION—Three Dollars per annum, in advance. Single copies, 10 cents.

AGENTS.

NEW YORK.—AMERICAN NEWS CO., 39 and 41 Chambers Street. PHILADELPHIA.—PRATT & CO., Corner Ninth and Arch Streets. Germany.—B. WESTERMANN & CO., of New York.

MONDAY, JANUARY 6, 1890.

Gas Stocks.

Quotations by Geo. W. Close, Broker and Dealer in Gas Stocks.

16 WALL ST., NEW YORK CITY.

JANUARY 6.

All communications will receive particular attention. The following quotations are based on the par value of \$100 per share.

Table of Gas Stocks with columns for Company Name, Capital, Par, Bid, and Asked prices.

Out of Town Gas Companies.

Table listing Boston United Gas Co. and its various series with prices.

Table of Bay State Gas Co. and other companies with columns for Stock, Income Bonds, and various financial metrics.

Advertisers Index.

Table listing various companies under categories like GAS ENGINEERS, GAS AND WATER PIPES, GAS WORKS APPARATUS AND CONSTRUCTION, etc.

Table listing various industrial processes and equipment under categories like PROCESSES, INCLINED RETORTS, GASHOLDER TANKS, etc.

GAS LAMPS.

G. Shepard Page, New York City.....	24
Standard Gas Lamp Co., Phila., Pa.....	15
Welsbach Incandescent Gas Light Co., Phila., Pa.....	18
The Siemens-Lungren Company, Philadelphia, Pa.....	18

PURIFIER SCREENS.

John Cabot, New York City.....	24
Bartlett, Hayward & Co., Baltimore, Md.....	24

GAS STOVES.

American Meter Co., New York and Philadelphia.....	25
The Goodwin Gas Stove and Meter Co., Phila. Pa.....	36
George M. Clark & Company, Chicago, Ills.....	18

STREET LAMPS.

J. G. Miner, Morrisania, New York City.....	933
Bartlett Street Lamp Man'fg Co., New York City.....	15

BURNERS.

C. A. Gefroerer, Phila., Pa.....	32
H. W. Rappleye, Phila., Pa.....	901

STEAM BLOWER FOR BURNING BREESE.

H. E. Parson, New York City.....	940
----------------------------------	-----

PURIFYING MATERIAL.

Connelly & Co., New York City.....	23
Friedrich Lux, London, England.....	16
Edgewater Lime Works, Edgewater, N. J.....	16

COKE CRUSHER.

C. M. Keller, Columbus, Ind.....	33
----------------------------------	----

ELECTRICAL APPARATUS.

Wm. Henry White, N. Y. City.....	53
----------------------------------	----

SOLVENTS.

Maas & Waldstein, New York City.....	16
--------------------------------------	----

WANTED,

A Superintendent for Gas and Electric Light Plant,

At Washington, Daviess County, Ind. Call at this Office for particulars.

SITUATION WANTED

As Inspector,

By man of experience, who understands stove work and the various lamps and burners, and all kinds of street work. Address "INSPECTOR," 760-2 Care this Journal.

Position Wanted

As Superintendent or Assistant of a Gas Works, By a man who can give the best of references. Thoroughly understands the manufacture and distribution of gas and the construction of works. Address 758-3 "C.," care this Journal.

FOR SALE,

Otto Gas Engine, 15-Horse Power,

With Counter Shafting, Belting, etc. Completely fitted for running electric lights. Used only 10 days; satisfactory reasons for selling. Address 761-2t "C. B.," Post Office Box 5104, Boston, Mass.

WANTED,

A Six-Inch Exhauster and a Six-Inch Governor,

Both in good order; second-hand. State price. 761-1 GAS COMPANY, care this Journal.

FOR SALE,

All the Appliances Necessary for the Passing of 100,000 Cubic Feet of Coal Gas per Day.

Now in operation at Stamford, Conn. Reason of sale, incapacity of present plant. For further information address 759-4 STAMFORD GAS LT. CO., Stamford, Conn.

FOR SALE.

A Complete Water Gas Plant. 60,000 Cu. Ft. Daily Capacity.

Fully equipped; all the latest improvements; includes Generator, Purifiers, and Holder. Can be removed to any part of the country, and set up at small cost. For further information apply to BRADFORD GAS LT. & HEATING CO., Dunkirk, N. Y.

GAS WORKS FOR SALE.

A CONTROLLING INTEREST IN SEVERAL Interior California Coal Gas Plants, now paying handsomely, are offered on very reasonable terms. This is an exceptionally good opportunity for practical gas men of limited means, wishing to remove to a mild and healthful climate, to acquire an established and paying business. Particulars given and full investigation solicited.

SECRETARY, 123 Beale Street, 760-1f San Francisco, Cal.

6 PER CENT.

First Mortgage Bonds

ON GAS WORKS

SITUATED IN GROWING WESTERN TOWNS.

Principal and Interest Guaranteed.

INTEREST SEMI-ANNUALLY.

For sale by the undersigned, who will furnish all necessary information regarding them.

JOS. R. THOMAS, 42 Pine St., N. Y. City.

Fuel and Its Applications.

By E. J. MILLS, D.Sc. F.R.S., and F. J. ROWAN, C.E., assisted by others, including Mr. F. P. Dewey, of the Smithsonian Inst., Wash., D. C.

7 PLATES, AND 607 OTHER ILLUSTRATIONS. ROYAL OCTAVO, PAGES XX, 802. HANDSOME CLOTH, \$7.50.

A. M. CALLENDER & CO., 42 Pine St., N. Y.

PATENTS.

FRANKLIN H. HOUGH

Solicitor of American & Foreign Patents.

925 F. ST., WASHINGTON, D. C.

(NEAR U. S. PATENT OFFICE.)

Personal attention given to the preparation and prosecution of applications for Letters Patent. All business before the U. S. Patent Office attended to for moderate fees. **No Agency in the United States possesses superior facilities for obtaining Patents,** or for ascertaining the patentability of inventions. Copies of patents furnished for 25 cents each. Correspondence solicited.



PHILADELPHIA.

STEPHEN A. MORSE, President.
GODFREY REBMANN, Vice-Pres.

NEW YORK.

EDWIN F. MORSE, Secretary.
CARLTON M. WILLIAMS, Treas.

CHICAGO.

STANDARD GAS LAMP CO.,

Main Office, 411 Cherry St. Factory, 1101, 1103, 1105 Frankford Av. PHILADELPHIA, PA.

It is to the interest of Gas Companies and Cities to double the efficiency of the light on streets by using Dyott's Patent "CHAMPION" LAMPS. They save 50 per cent. over others in cost of repairs, are ornamental, and indestructible except by violence.

Our Patent System of Instantaneously Lighting Gas (without electricity), for Railroad Depots is unequalled. Dyott's High Candle Power Burner is a very superior lamp where a concentrated and brilliant light is wanted in Hotels, Stores, Depots, etc.

Special Drawings furnished and Estimates cheerfully given, either from Architects', Engineers', or our Draughtmen's Plans. We manufacture every description of Plain and Ornamental Lamps, Posts, Brackets, Clusters, etc. Correspondence solicited.

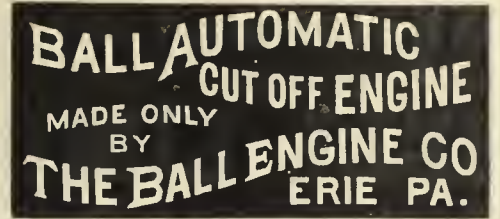
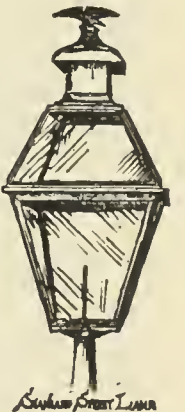

Simpkin & Hillyer

RICHMOND, VA.

MANUFACTURERS OF

Gas Works Apparatus

BENCH CASTINGS, CONDENSERS,

Scrubbers, Purifiers, Dry Center Seals,

FOUR-WAY VALVES, GAS VALVES,

SULPHATE OF AMMONIA APPARATUS, TANKS, ENGINES, BOILERS, PUMPS, ETC., ETC.

Plans, Specifications and Estimates furnished for new works, or alteration of old works. Correspondence solicited. Works, Newport News, Va.

Bartlett Street Lamp Mfg. Co.

MANUFACTURERS OF

Globe Lamps,

FOR

Streets, Parks, Public Buildings, Railroad Stations, etc.

LAMP POSTS

A Specialty.

Office and Salesroom,

40 & 42 COLLEGE PLACE, - - N. Y. CITY.

Gas Companies and others intending to erect Lamps and Posts will do well to communicate with us.

GASHOLDER PAINT.

Use Only

THE GOVERNMENT WATERPROOF PAINT.

Proof against Ammonia, and Absolutely Waterproof. Send for Prices and Particulars.

THE GOVERNMENT WATERPROOF PAINT CO., 122 Milk Street, Boston, Mass.

EDGEWATER LIME WORKS

Chas. F. McKenna, Proprietor.

SHELL LIME.

Lime by the Cargo for Gas Purification.

EDGEWATER, BERGEN CO., N. J.

Write for Testimonials and Prices.

FRIEDRICH LUX,

Ludwigshafen am Rhein and London.

Lux Mass

GAS GOVERNORS,

Gas Balance.

GEROULD'S

System Gas Bookkeeping.

Approved and adopted by many of the prominent Gas Engineers of the Country.

Sample Sheets and Price-List furnished free on application to

L. P. GEROULD, - - Mendota Ill.

(Patented.)

IMPORTANT!

(Patented)

NEW SOLVENT FOR GAS PIPE DEPOSITS.

Economical and Effective.

MAAS & WALDSTEIN, 44 Trinity Place and 81 Greenwich St., N. Y.

Gasholder Tanks & Gas Works Masonry Complete.

PLANS PREPARED AND ESTIMATES FURNISHED AT SHORT NOTICE.

J. P. WHITTIER, - - 499 Wythe Av., Brooklyn, N. Y.

HENRY PRATT & CO.,

BUILDERS OF THE

PRATT & RYAN WATER GAS GENERATORS,

Arranged to Use Either Crude Oil or Naphtha.

Condensers, Scrubbers, Purifiers, and all Apparatus for Coal or Water Gas.

IRON ROOFS, BOILERS, TANKS, ETC.

Orders and Correspondence Solicited.

Plans and Estimates Furnished for New Works or for the Alteration of Old Works.

Office and Works, 869 to 875 So. Halsted St. CHICAGO, ILL.

LACLEDE FIRE BRICK MANUFACTURING COMPANY,

ST. LOUIS, MO.

Exclusive Agents in the United States

FOR THE

Coze System of Inclined Retorts.

IT IS THE COMING BENCH FOR MAKING COAL GAS.

It will Save from 50 to 60 per ct. in Labor.

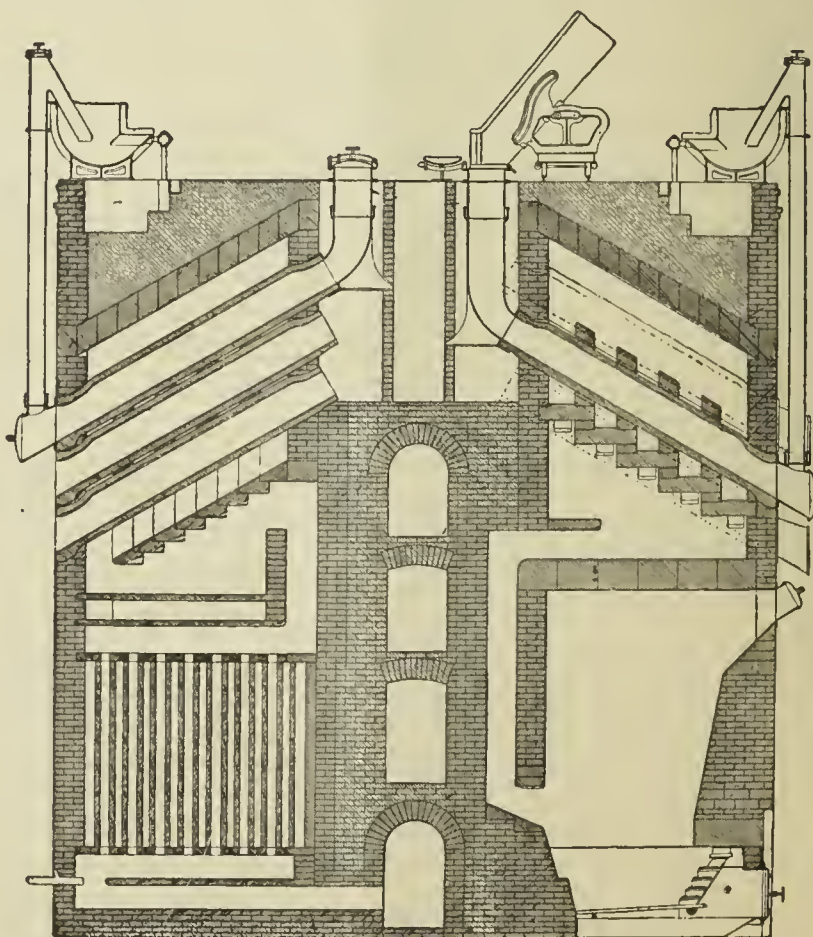
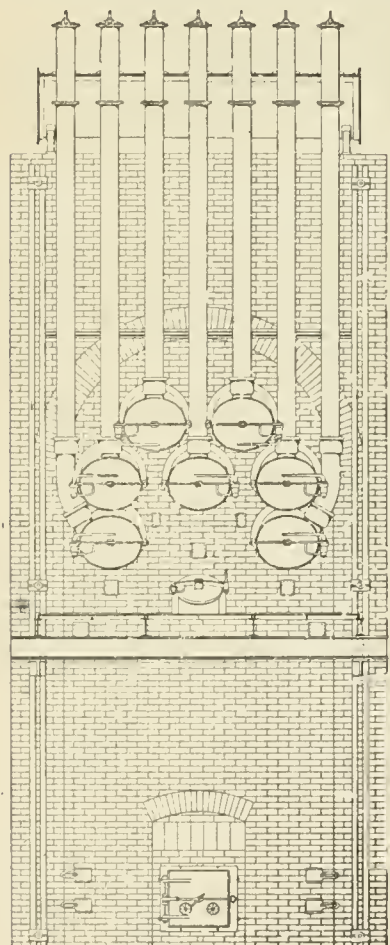

ESTIMATES AND PLANS FURNISHED BY THE

LACLEDE FIRE BRICK MFG. CO., ST. LOUIS, MO.

The Gordon Portico Lamp.

A successful Competitor of the Arc Electric Light for lighting Store Fronts, Show Windows, Depots, Railway Sheds, etc., etc.

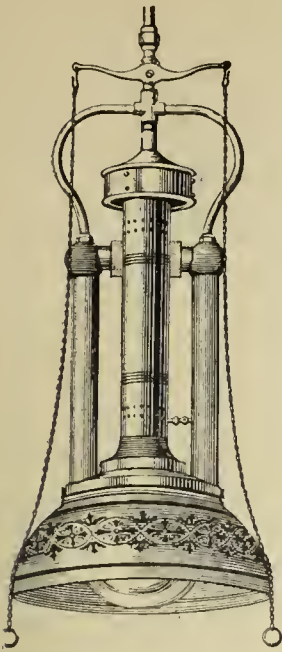

Gordon Portico Lamp.

The Gordon Street Lamp.

A Successful Competitor of the Arc Electric Light for lighting Streets, etc., etc.

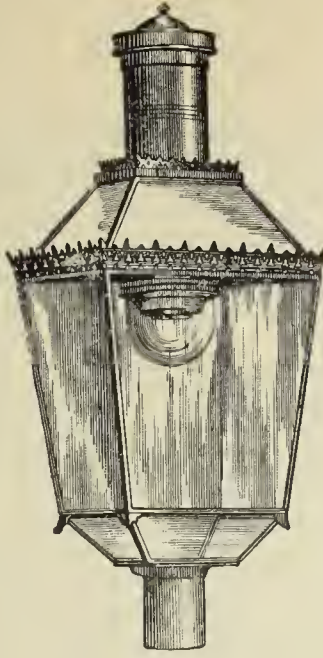

Gordon Street Lamp.

The Lungren Lamp.

A Successful Competitor of the Incandescent Electric Light for Interiors, etc. Is especially applicable for the lighting of Offices, Stores, Factories, Mills, Show Windows, Libraries, and all situations where an increased illumination is desired.

More than 25,000 Lungren Lamps are now in use. Testimonials, references, or any desired information will be cheerfully given.

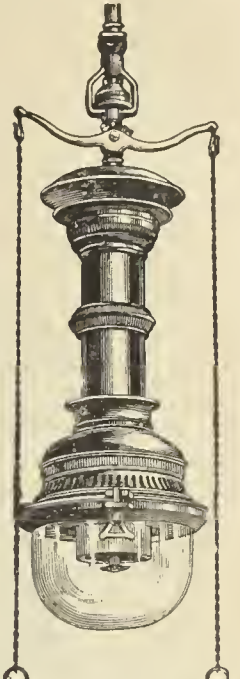

Lungren Lamp.

THE SIEMENS-LUNGREN CO., N.E. Cor. 21st St. & Washington Av., PHILADELPHIA.

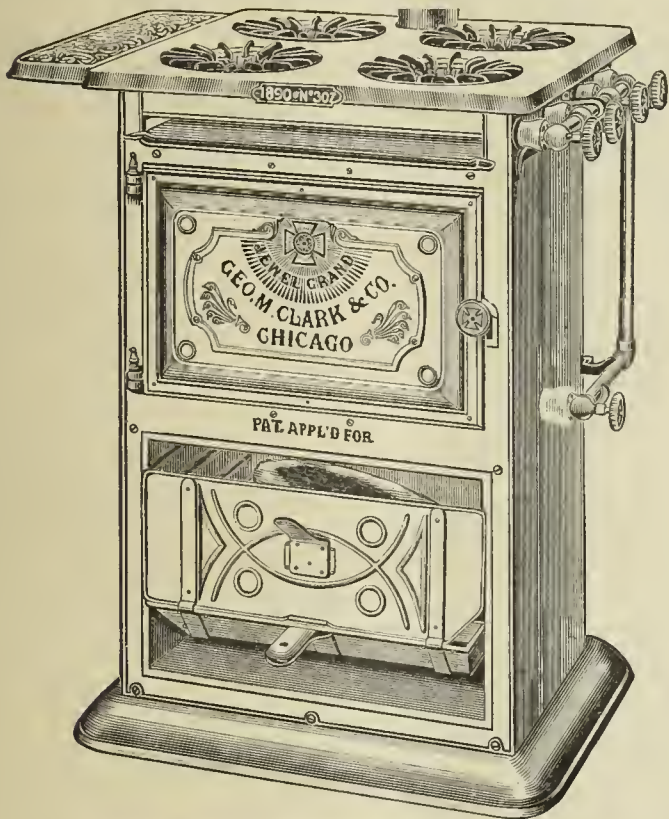

JEWEL GAS STOVES

MANUFACTURED BY

GEORGE M. CLARK & COMPANY,

Nos. 157 & 159 Superior Street, - - - Chicago, Ill.

EVERY CONCEIVABLE SIZE AND STYLE,

Ranging in Prices from \$1.50 to \$30.00.

WE USE NO GAS COCKS.

All Flames are Regulated by a Direct Needle Valve.

The **JEWEL**

IS THE

Only Well-Made Gas Stove on the Market.

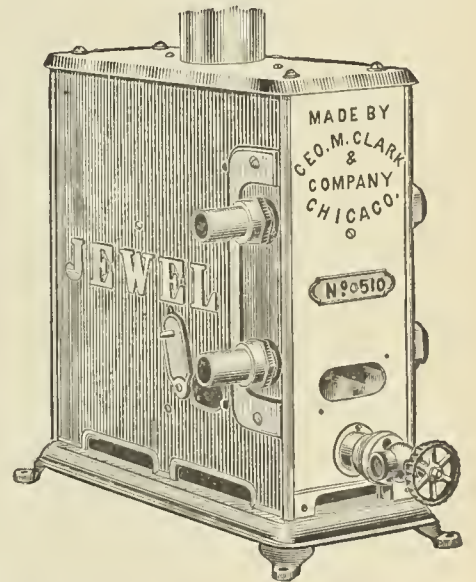

Write for our 1890 Catalogue and see for yourself.

A. & W. S. CARR CO. IRON PIPE, VALVES, 38 CENTREST. GATES, FITTINGS, PLUMBERS SUPPLIES. AND 140 NEW YORK.

WELSBACH SYSTEM OF Incandescent Gas Lighting.

OFFICE, DREXEL BUILDING, PHILA., PA.

At the Fall Session of the Board of Supervisors of Winnebago County, held at the County Court House, Oshkosh, Wis., Nov. 26, 1889, the report submitted by Mr. C. W. Cook, Chairman of the Committee on Public Buildings, recommending the use of the Welsbach Incandescent Gas Burner in the Buildings under their charge, was unanimously adopted, because of the extreme economy in the consumption of Gas and the superior character of the light obtained.

C. & W. WALKER'S PAT. PURIFYING MACHINE.

TAKING ALL THE WORK FROM THE OUTLET OF THE CONDENSER TO THE INLET OF THE PURIFIERS.

Patented in Great Britain and Ireland, Australia, France Germany, Italy, and the United States.

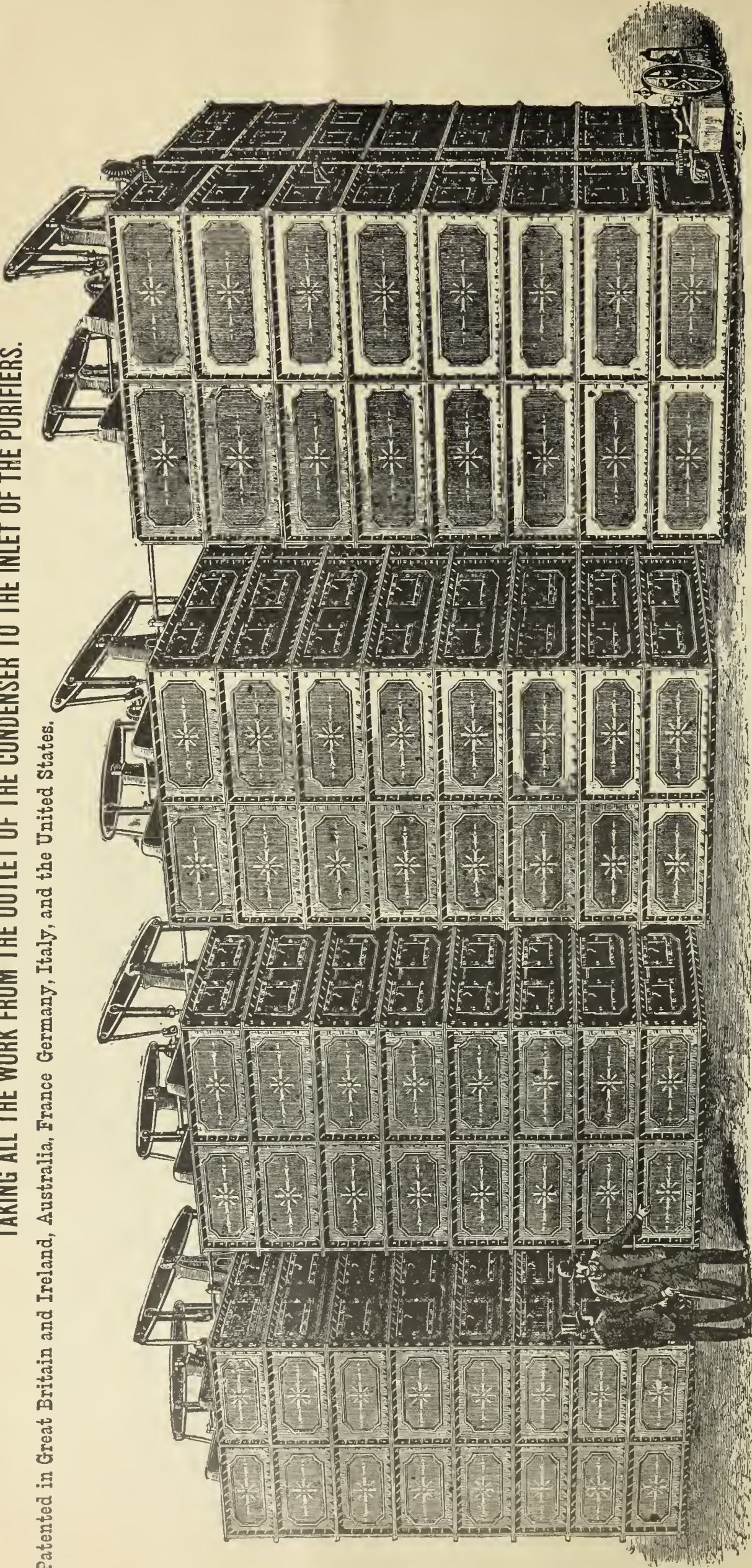

These Four Machines Purify 12 Millions per Day, and only occupy a Ground Space of 60 ft. by 12 ft., and are 23 ft. 6 in. High.

Four of these powerful Machines for the new extensions at the Beckton Gas Works, London, are now working, purifying Twelve Million Cubic Feet of Gas per day, each Machine taking Three Millions per day.

These Machines can be seen at Beckton, where, after being long and abundantly tried, tested, and proved in every variety of working, have been accepted by the Gas Light and Coke Company, of London, as superior to all other apparatus for taking all the work of the purification of gas between the Condensers and the Purifiers.

The Machine is the most important improvement effected in gas works for years past. The purifying power developed is most remarkable. We send an Engineer with a working model to any Gas Company inviting information. It is equally adapted to gas works of any size.

DESCRIPTION.

The gas enters into the washing chamber at the lowermost part, where it is first subjected to a thorough washing in the strong Ammoniacal Liquor. The washing is most effective. The entire surface of the Ammoniacal Liquor is in a bubbling state of ebullition, presenting an

agitated, frothy surface all over. All the Tar left in the gas after surface condensation is here completely extracted, and a large amount of Carbonic Acid.

The gas, thus so far purified, ascends from the washing chamber and passes from one superposed chamber to another in contact with the enormous amount of movable, constantly dipping wetted surfaces, leaving the uppermost chamber entirely purified from Ammonia, meeting the chemical requirements of the Board of Trade.

The Machine is self-cleansing, and can never choke or stop up; and in this important respect it is superior to all Machines heretofore known. The space occupied by the Machine is very small. In most cases it can be placed in the space inside the end of the Purifying House. Its cost is less than any other known apparatus for purifying gas from Tar and Ammonia.

These Machines are at work and in hand for Widnes, Burnley, and Oswaldtwistle, in Lancashire; at Harrogate and Wakefield, in Yorkshire; at Salford, in Cheshire; at Stone, in Staffordshire; also at Cheltenham and Northampton, also at Melbourne, in Australia.

Apply, until American Agency is appointed, to

C. & W. WALKER, 8 Finsbury Circus, London.

THIS SPACE
WILL BE
Occupied Next Month by the
KERR MURRAY MFG. CO.
FORT WAYNE, IND.
**GAS WORKS
APPARATUS
AND
HOLDERS.**

F. J. DAVIS & J. R. FARNUM,
TRUSTEES AND AGENTS FOR THE
SINUOUS FRICTION CONDENSER.

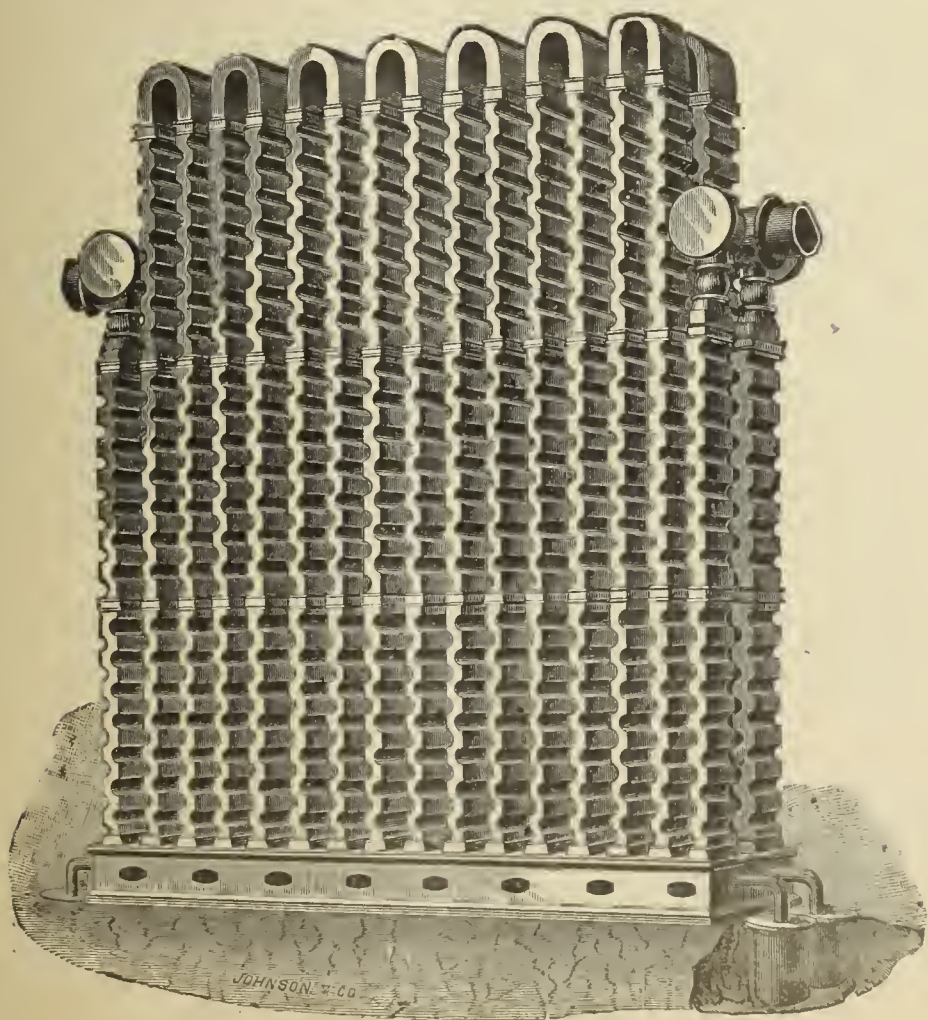

We desire to draw the attention of the gas community to the merits of the **SINUOUS FRICTION CONDENSER**. Companies intending to introduce new condensers into their works will do well to confer with us and examine plans and estimates before contracting for any other pattern. The **FRICTION CONDENSER** is now in use at the gas works located in the following places:

- | | | | |
|--------------------------------|------------------|-------------------------------|---------------------|
| Portland, Me. | Brookline, Mass. | Pawtucket, R. I. | Frederickton, N. B. |
| Newport, R. I. | Chelsea, Mass. | Jamaica Plain, Mass. | St. John, N. B. |
| Gloucester, Mass. | Woburn, Mass. | Attleboro, Mass. | Paterson, N. J. |
| Newton & Water-
town, Mass. | Peoria, Ill. | Calais, Me. | Dover, N. H. |
| | Clinton, Mass. | Fall River, Mass. | Waltham, Mass. |
| | | Nassau Works, Brooklyn, N. Y. | |

DAVIS & FARNUM MFG. CO.

MANUFACTURERS OF

Gas and Water Pipes,

AND

GAS AND WATER MACHINERY

OF THE MOST APPROVED PATTERN.

Also, Gasholders and Iron Roofing.

Orders from Gas and Water Companies promptly attended to.

WALTHAM, MASS.

Office, Room 55, Mason Building, 70 Kilby Street. Boston

THE WALKER TAR AND CARBONIC ACID EXTRACTOR.

A very general demand exists, in both large and small Gas Works, for an apparatus that will be absolutely efficient in the removal of the tar which passes the hydraulic main and condenser. Many attempts have been made to accomplish this, but, I believe, without success, until the introduction, five years ago, in England, of the C. & W. Walker Patent Tar and Carbonic Acid Extractor. During these years this apparatus has been adopted by many of the most prominent Engineers, not only in England, but also on the Continent of Europe and in other parts of the world. It is only necessary to give here a partial list in order to convince any intelligent American Gas Engineer that this machine must have succeeded fully in accomplishing the desired results.

The following Engineers have personally given permission to refer to them:

G. C. Trewby, Esq., Engineer-in-Chief of the Gas Light and Coke Co., London. The manufacturing plant at Beckton is built in complete sections of 3,000,000 cubic feet capacity each. A Walker Tar Extractor has been fitted to each one of these sections. This was done after a long and thorough trial on one of its sections. The Tar Extractor has been supplied to other works of the Gas Light and Coke Co., including those of which John Methven, Engineer of the Gas Light and Coke Co. at the Nine Elms Station, is in charge. Also to G. E. Stevenson, Peterborough Gas Works; B. Green, Mitcham and Wimbledon Gas Works; W. H. Smith, Bedford Gas Works; F. Linging, Norwich Gas Works; J. T. Browning, Colchester Gas Works; S. B. Darwin, Portsmouth Gas Works; J. McCrae, Dundee Gas Works; W. J. Wells, Stamford Gas Works; J. M. Darwin, Longton Gas Works; J. Paterson, Warrington Gas Works; and J. Coulter, of the Dundalk Gas Works. All of the foregoing gas works are located in Great Britain.

Mr. Charles A. Gerdenier, Superintendent of the Bridgeport (Conn.) Gas Light Company, writes as follows, under date of Dec. 3, 1887:

“The C. & W. Walker Tar and Carbonic Acid Extractor has been in operation at these works for the past six weeks, and is an unqualified success. It removes every particle of Tar from the gas in once passing through the apparatus and a large percentage of the Carbonic Acid. I also feel quite sure that it prevents the formation and deposit of Naphthaline, because since I started the Washer I have had no stoppages from this cause. These works have been seriously troubled with Tar for many years, and I have used several kinds of apparatus and every expedient which has come to my attention for dealing with the difficulty, but without success. The Walker apparatus occupies comparatively small space, is less expensive than other systems, and requires but little attention. I carry 24-inch seal, and have an automatic tar delivery valve. This Tar Extractor is indispensable to gas makers.”

I have taken the Agency for the United States for this apparatus, and am now prepared to make contracts to erect it on the premises of any Gas Company. It would be manufactured in the following sizes:

No. 1,	50,000 to	100,000	cu. ft. per 24 hrs.,	3 ft. square,	5 ft. deep.
No. 2,	“	125,000	“	4 “	“
No. 3,	“	250,000	“	5 “	“
No. 4,	“	500,000	“	6 “	“
No. 5,	“	750,000	“	7 “	“
No. 6,	“	1,000,000	“	8 “	“
No. 7,	“	1,250,000	“	9 “	“
No. 8,	“	1,500,000	“	10 “	“
No. 9,	“	2,000,000	“	12 “	“
No. 10,	“	3,000,000	“	15 “	“

This Tar Extractor will perform its work with about one-fourth the usual back-pressure heretofore required. It is simple in construction, and can be supplied at a very reasonable price—less than any other ever before introduced. Satisfactory results will be guaranteed in every instance.

GEO. SHEPARD PAGE,

SOLE AGENT FOR THE UNITED STATES,

No. 69 Wall Street, - - - New York,

THE UNITED GAS IMPROVEMENT CO.

DREXEL BUILDING, PHILADELPHIA.

OFFICERS:

WILLIAM W. GIBBS, President.

GEORGE PHILLER, Vice-President.

SAM'L T. BODINE, Gen'l Manager.

RANDAL MORGAN, Gen'l Counsel.

EDWARD C. LEE, Sec'y and Treas.

ALEX. C. HUMPHREYS, Gen'l Supt.

WALTON CLARK, Ass't Gen'l Supt.

H. H. EDGERTON, Chem. and Eng'r.

DIRECTORS:

GEORGE PHILLER,

THOMAS DOLAN

HENRY C. GIBSON,

WM. T. CARTER,

WILLIAM G. WARDEN,

SAM'L T. BODINE.

BUILDERS, LESSEES AND PURCHASERS OF

➤ GAS WORKS. ➤

Orders solicited from Large Cities, Small Towns, Mills, Institutions, from all who want more Light for Less Money.

NATIONAL GAS LIGHT AND FUEL COMPANY,

No. 218 La Salle Street, Chicago.

THE SPRINGER SYSTEM

OF

Fuel and Illuminating Water Gas Works.

REFERENCES.

People's Gas Lt. & Coke Co.. Chicago, Ill.
 Illinois Light, Heat & Power
 Co..... Chicago, Ill
 Elgin National Watch Co.. Elgin, Ill.
 C. R. I. & P. R. R. Shops.. Chicago, Ill.
 Decatur Gas Lt & Coke Co.. Decatur, Ill.
 Niles Gas Light Co..... Niles, Mich.
 Newton Illuminating Co... Newton, Kansas.
 Wellington Light & Heat Co.. Wellington, Kansas.
 Chippewa Falls Gas Lt. Co.. Chippewa Falls, Wis.
 Elkhart Gas Lt & Coke Co.. Elkhart, Ind.
 Madison City Gas Light Co.. Madison, Wis.
 South Bend Gas Light Co.. South Bend, Ind.
 Sheboygan National Gas Co.. Sheboygan, Wis.
 Salina Gas Light Co..... Salina, Kansas.
 The Rathbun Co..... Deseronto, Prov. Ont.
 Jefferson City Gas Lt. Co.. Jefferson City, Mo.
 Mankato Gas Light Co.... Mankato, Minn.
 Lima Gas Light Co... Lima, Ohio.

Minneapolis Gas Light and
 Coke Co..... Minneapolis, Minn.
 Bellevue Water and Fuel }
 Gas Light Co..... } Bellevue, Campbell
 County, Ky.
 Bucyrus Gas Lt. & Fuel Co.. Bucyrus, Ohio.
 Morris Gas Co..... Morris, Ill.
 Los Angeles Gas Co..... Los Angeles, Cal.
 San Diego Gas Fuel & Elec-
 tric Lt. Co..... San Diego, Cal.
 Sioux Falls Gas Co..... Sioux Falls, Dak.
 Dakota Gas and Fuel Co.. Grand Forks, Dak.
 St. Johns Mutual Gas Co... St. Johns, Mich.
 Stillwater Gas Light Co... Stillwater, Minn.
 St. Paul Gas Light Co.... St. Paul, Minn.
 Emporia Electric and Gas
 Light Co..... Emporia, Kas.
 Van Wert Gas Light Co... Van Wert, Ohio.
 Lansing Gas Light Co..... Lansing, Mich.
 San Francisco Gas Lt. Co... San Francisco, Cal.

Shelbyville Gas Light Co... Shelbyville, Ind.
 Great Falls Gas Light Co... Great Falls, N. H.
 Belleville Gas Co..... Belleville, Ontario
 Rochester Lt. and Fuel Co.. Rochester, Minn.
 Northwestern Gas Light and
 Coke Co..... Evanston, Ill.
 Lincoln Gas Light Co.... Lincoln, Neb.
 Davenport Gas Light Co... Davenport, Iowa.
 Municipal Gas Co..... Albany, N. Y.
 Alliance Gas Light Co.... Alliance, Ohio.
 New Gas Light Co..... Janesville, Wis.
 *Chicago Gas Light & Coke
 Co..... Chicago, Ill.
 *Joliet Gas Co..... Joliet, Ills.
 *Superior Light & Fuel Co.. Superior, Wis.
 *Kewanee Gas Light Co... Kewanee, Ill.
 *Standard Gas Light Co... New York City.

* Building.

GUARANTEED ESTIMATES of Cost of Gas Furnished on Application.

GASHOLDER TANK CONSTRUCTION, ETC.

Gas Companies and others about to erect Gasholders will find it profitable to consult W. C. Whyte, who for over 30 years has made a specialty of

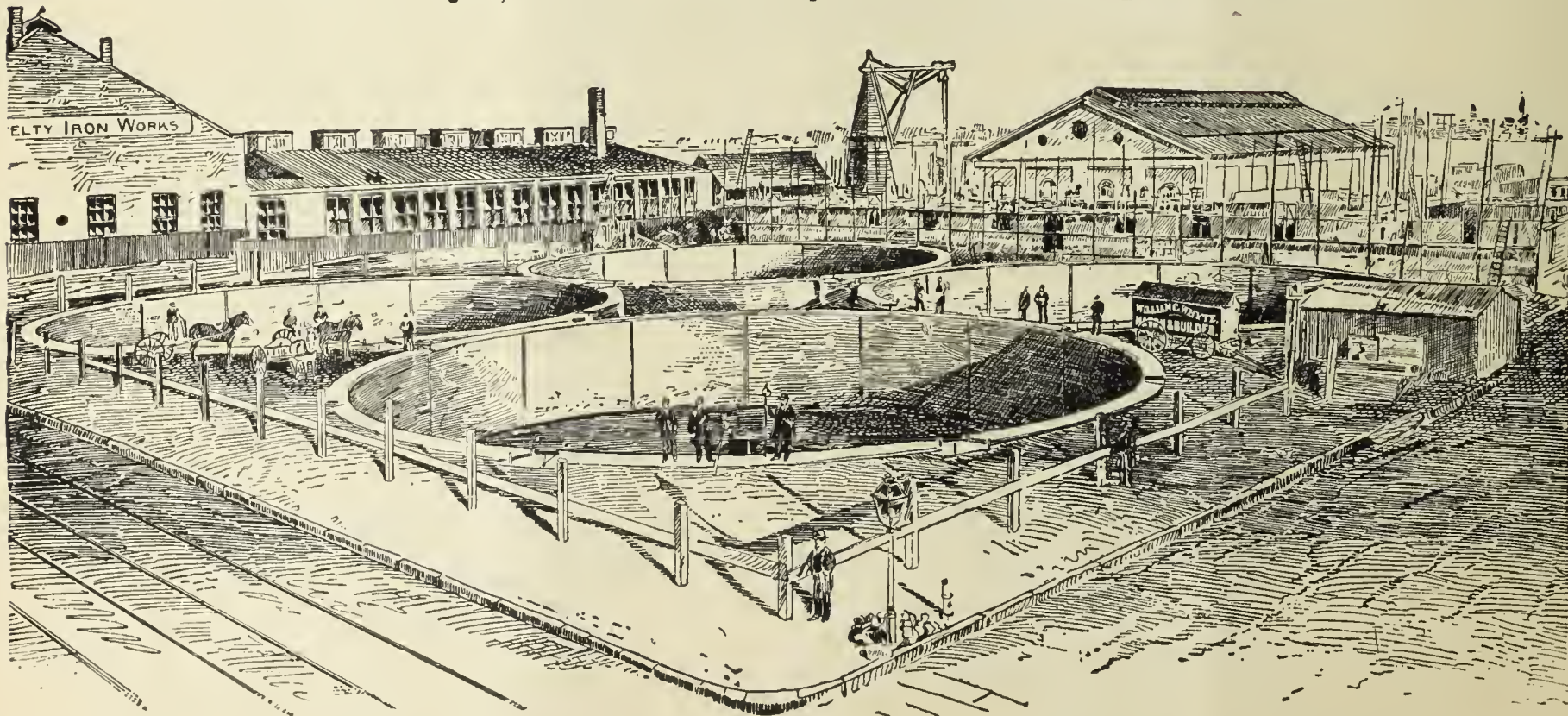

Tank Excavation and Mason Work.

Fifty Tanks now in operation show the sort of work done. Address

W. C. WHYTE, - No. 15 Cortlandt Street, N. Y. City.

CONNELLY & CO.,

SOLE MANUFACTURERS OF THEIR PATENTED SPECIALTIES.

"IRON SPONGE." Saves money, saves labor, and is the most efficient purifying agent ever offered as a substitute for lime. Now used in every State in the Union, and purifying daily over thirty-five million cubic feet. Should be used in every gas works. Its own saving will pay for it many times over.

AUTOMATIC GOVERNOR. Has been on the market but three years, and in that time has been introduced more generally than any invention ever designed for use in gas works. Over two hundred of them now in use. Sensitive; reliable; perfectly automatic; reduces leakage; satisfies consumers, and gives great relief to the Manager. No gas works is complete without one of these machines.

STEAM JET EXHAUSTER. Designed particularly for small works. Combines Exhaust Tube, Steam Governor Gas Compensator, and Bye-Pass Valves in the most compact form possible; occupies but little space; uses very little steam; operated by ordinary workmen; saves formation of carbon in retorts; increases yield 10 to 15 per cent. Specially adapted for mixing air with oil gas. No works too small to use them profitably.

Prices given on all our specialties delivered at any point in the United States. Correspondence solicited.

CONNELLY & CO., No. 111 Broadway, New York City.

WILBRAHAM GAS EXHAUSTER & ENGINE COMBINED.

WILBRAHAM BROS.,
PHILADELPHIA, PA.

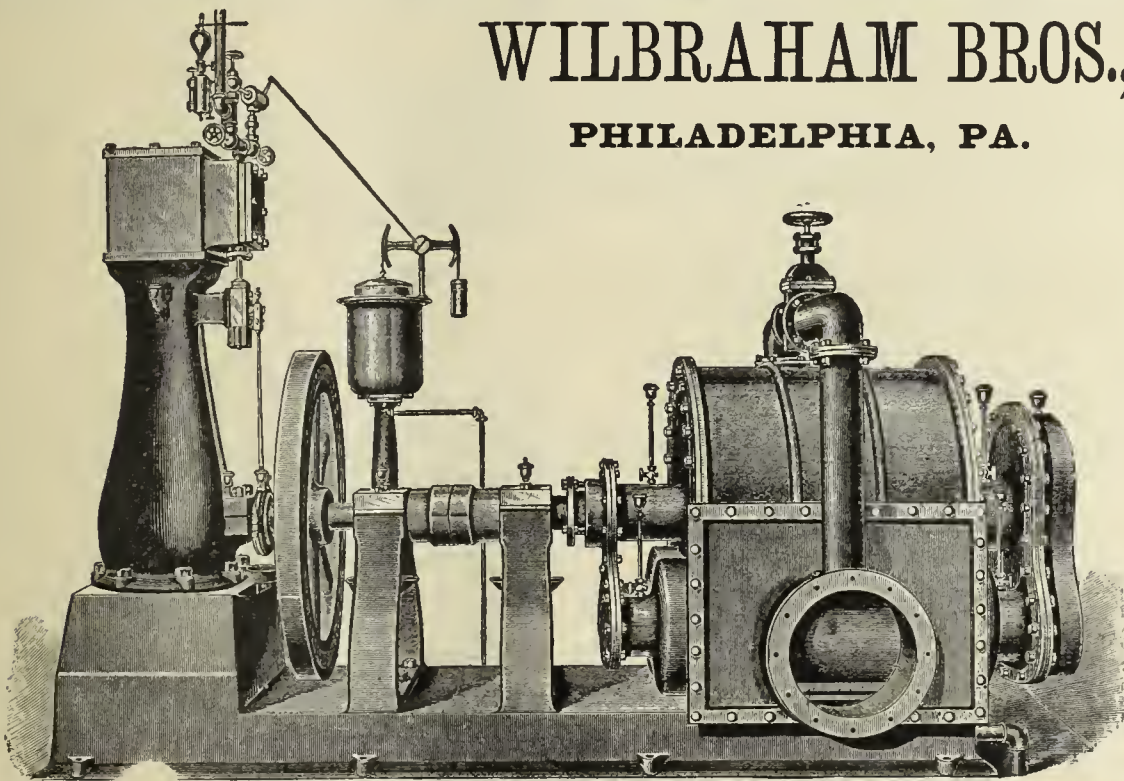

JARVIS ENGINEERING CO.,

61 Oliver St., Boston, Mass.

CONTRACTORS FOR ERECTING

COMPLETE STEAM OUTFITS FOR ELECTRIC LIGHTING STATIONS.

Steel Boilers set with Jarvis Pat. Boiler Setting

To burn **COKE SCREENINGS** for Fuel.

ARMINGTON & SIMS CO. ENGINES,

Belting direct to Dynamos, without using Shafting.

SEND FOR CIRCULARS.

REFERENCES.—Charlestown Gas & Electric Light Co., Charlestown, Mass.; Schenectady Gas & Electric Light Co., Schenectady N. Y.; Brookline Gas Co., Brookline, Mass.

Practical Electric Lighting

By A. BROMLEY HOLMES, A.M.I.C.E.

With 87 Illustrations. Third Edition. Price, \$1.00.

Electric Light Primer.

By CHARLES L. LEVEY.

A simple and comprehensive Digest of all the most important facts connected with the running of the Dynamo and Electric Lights, with Precautions for Safety, etc.

Price, 50 cents.

A. M. CALLENDER & CO., 42 Pine St., N. Y.

COMPOUND

Condensing or Non-Condensing.

16 SIZES, 5 to 500 H. P.

Not yet equaled by any form of Engine for HIGH FUEL DUTY AND SIMPLICITY.

STANDARD

13 Sizes in Stock.

5 to 250 H. P.

3000 in use in all parts of the Civilized World.

JUNIOR

6 Sizes in Stock,

5 to 50 H. P.

An Automatic Engine cheaper than a Slide Valve. WELL BUILT. ECONOMICAL. RELIABLE.

Over 300 Sold the First Year.

All the above built strictly to Gauge with INTERCHANGEABLE PARTS.

REPAIRS CARRIED IN STOCK.

SEND FOR ILLUSTRATED CATALOGUES.

WESTINGHOUSE ENGINES
 The Westinghouse Machine Co.
 PITTSBURGH, PA. U.S.A.

SELLING DEPARTMENT IN THE UNITED STATES.

New York,	47 Cortlandt St.	} Westinghouse, Church, Kerr & Co.
Boston,	Hathaway Building,	
Pittsburgh,	Westinghouse Build'g,	
Chicago,	156, 158 Lake St.	
Philadelphia,	608 Chestnut St. M. R. Muckle, Jr. & Co.	
St. Louis,	302, 304 Washington Av.	} Fairbanks & Co.
Kansas City,	312 Union Avenue,	
Denver,	1330 Seventeenth St.	
Omaha,	1619 Capitol Avenue, F. C. Ayer.	
Pine Bluffs, Ark.		Geo. H. Dilley & Sons.
Salt Lake City,	255 S. Main St.	} Utah & Montana Machinery Co.
Butte, Mont.	L. Granite St.	
San Francisco,	21, 23 Fremont Street,	Parke & Lacy Co.
Portland, Or.	33, 35 N. Front St.	Parke & Lacy Mch. Co.
Charlotte, N. C.	36 College St.	} The D. A. Tompkins Co.
Atlanta, Ga.	45 S. Prior St.	
Dallas, Tex.		Keating Imp. & Machine Co.
Chattanooga, Tenn.,		C. E. James & Co.



CHAPMAN VALVE MANUFACTURING CO.,

MANUFACTURERS OF

Valves and Gates for Gas, Ammonia, Water, Etc.

Also, Gate Fire Hydrants With and Without Independent Nozzle Valve. All Work Guaranteed.

WORKS & GEN'L OFFICE:
Indian Orchard, Mass.

TREASURER'S OFFICE:
72 Kilby & 112 Milk Sts, Boston, Mass.

LUDLOW VALVE MFG. CO.

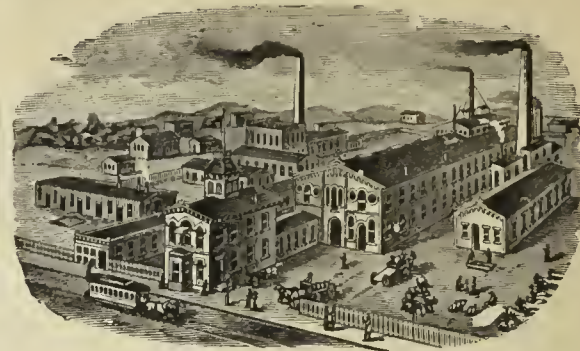

OFFICE AND WORKS,

938 to 954 River Street and 67 to 83 Vail Av.,
TROY, N. Y.

GEO. SHEPARD PAGE,

No. 69 Wall Street, N. Y. City.

REPRESENTING

THE BOWER GAS LAMP.

C. & W. Walker's Carbonic Acid & Tar Extracting Washer

B. DONKIN & CO.'S PAT. IMP. GAS VALVE.

Young & Beilby's Patents. Henry Aitkin's Patents.

R. P. SPICE, London, Eng. HENRY SIMON, Manchester, Eng.

MILLS' REVERSIBLE LIME TRAY,

AND

WOODWORK

Of Every Description

NEEDED BY GAS WORKS.

SEND FOR CIRCULAR AND PRICE LIST TO

BARTLETT, HAYWARD & CO.,

Pratt and Scott Streets, Baltimore, Md.

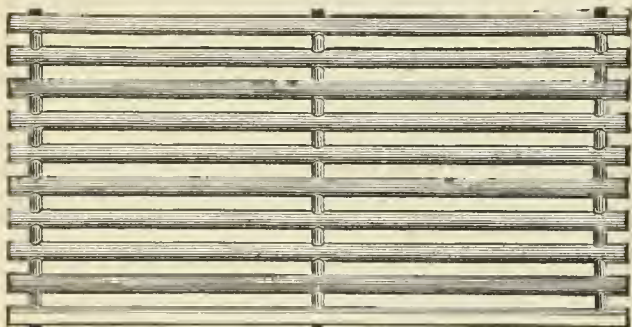

Hydraulic Main Dip Regulators, also
Check Valves, Foot Valves, Yard-
wash and Fire Hydrants.
Send for Circulars.

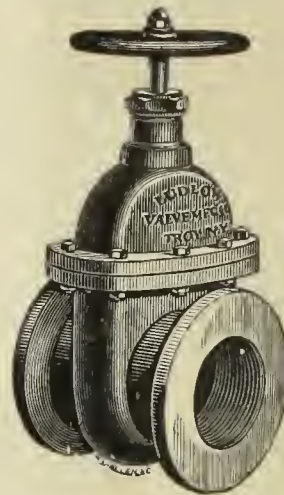

Valves.—Double and Single Gate, ½ in. to
48 in., outside and inside Screws. Indica-
tor, etc., for Gas, Water, Steam, and Oil.
Send for Circulars.

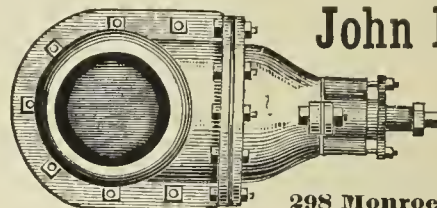

John McLean

Man'facturer

**GAS
VALVES.**

298 Monroe Street, N. Y.

SPECIAL TRAYS FOR IRON SPONGE OR OXIDE OF IRON.

CHURCH'S TRAYS A SPECIALTY.

REVERSIBLE-STRONGEST-MOST DURABLE-MOST EASILY REPAIRED.

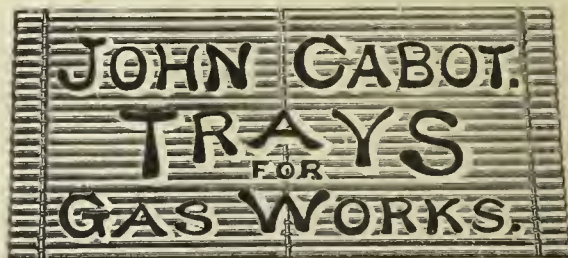

306-310 ELEVENTH AVENUE, NEW YORK.

WE ALSO MAKE THE CHEAPEST AND STRONGEST
REVERSIBLE BOLTED TRAYS IN THE MARKET.

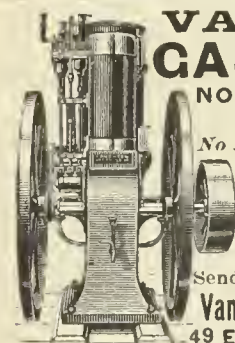

**VAN DUZEN
GAS ENGINE**

NO BOILER. NO COAL.
NO ENGINEER.

No Extra WATER RENT
or INSURANCE.

INSTANTLY STARTED.
DURABLE, RELIABLE,
SAFE and ECONOMICAL.

Send for description and prices.

Van Duzen Gas Engine CO.,
49 E. 2nd St., CINCINNATI, O.

A. MacKinnon Machine Co., Agts., 22 Warren St., N.Y.

**The Management of Small
Gas Works.**

BY C. J. R. HUMPHREYS.

Price, \$1.

Orders to be sent to **A. M. CALLENDER & CO.,**

42 PINE STREET, NEW YORK.

THE CLERK GAS ENGINE CO.,

Main Office, 1012, 1014, 1016, 1018 Filbert St., Philadelphia, Pa.

WM. W. GOODWIN, Prest.

E. STEIN, Sec.

S. LEWIS JONES, Asst. Sec.

A. J. DOTY, Supt.

The utility and convenience of the Gas Engine being no longer an open question, it only remains now for intending purchasers to select the BEST. We claim for the CLERK GAS ENGINE that it is equal to any other manufactured as regards steadiness in running, simplicity, and ease of keeping in repair, and that it gives the greatest amount of power for the least money (both in first cost and expense of running) of any engine made. In support of this claim we refer to the test of the Gas Engines made under the direction of the American Institute of New York, in December, 1885, and heretofore published in these columns. These engines are especially adapted for continuous running under heavy loads, and we can refer to Engines which have run 22 hours a day for months at a time

Made in Sizes of 5 10 15 20, and 25 Horse Power. All Engines Guaranteed for One Year.

GAS STOVES.

GAS METERS.

GAS STOVES.

THE AMERICAN METER CO.,

MANUFACTURERS OF

GAS METERS, Station Meters,

METER PROVERS, PHOTOMETERS,

PRESSURE GAUGES OF ALL KINDS,

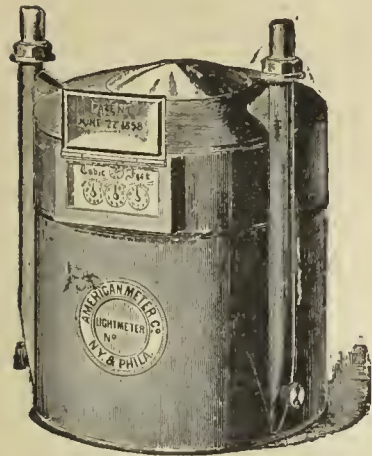

Standard 3 Diaphragm Dry Meter

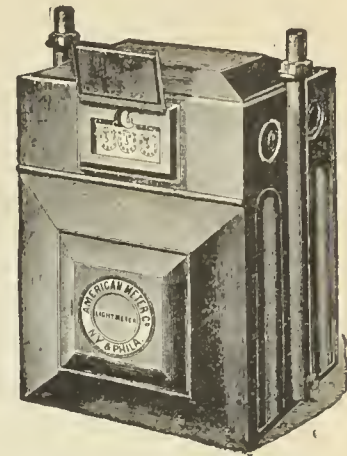

Standard 2 Diaphragm Dry Meter.

AND

Apparatus for Testing the Quantity and Quality of Gases.

GAS STOVES FOR HEATING AND COOKING

Sole Agents in the United States for

Verity's Patent Gas Fires.

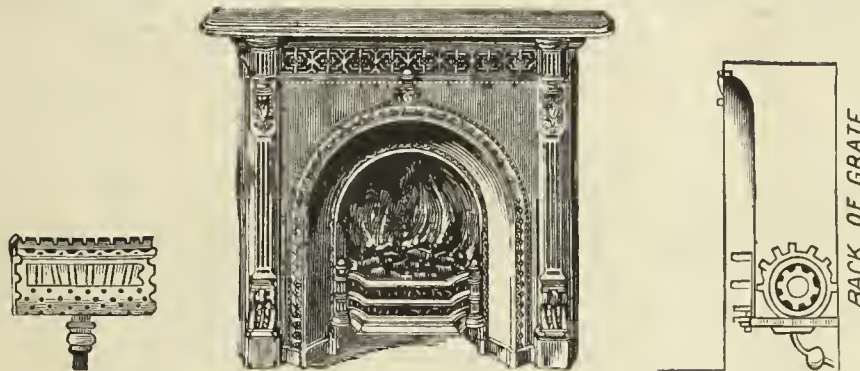

Circulars and Price Lists on Application.

MANUFACTORIES,

508 to 514 West Twenty-second St., N. Y.

Arch and Twenty-second St., Phila.

Nos. 244 & 246 North Wells Street, Chicago, Ill.

AGENCIES,

No. 177 Elm Street, Cincinnati, Ohio.

No. 222 Sutter Street, San Francisco, Cal

No. 810 North Second Street, St. Louis, Mo.

GAS STOVE SHOW ROOMS, No. 242 Sixth Avenue, New York City.

RETORTS AND FIRE BRICK.

RETORTS AND FIRE BRICK.

RETORTS AND FIRE BRICK.

J. H. GAUTIER & CO.,
CORNER OF
GREENE AND ESSEX STREETS,
JERSEY CITY, N. J.

MANUFACTURERS OF
**Clay Gas Retorts,
Gas House Tiles,
Fire Bricks, Etc. Etc.**

Ground Clay, Fire Brick and
Fire Sand in Barrels,

J. H. GAUTIER. C. E. GREGORY. C. E. GAUTIER.

BROOKLYN
Clay Retort & Fire Brick Works,
(EDWARD D. WHITE & CO.)
Manufacturers of Clay Retorts, Fire Brick,
Gas House and other Tile.
VAN DYKE, ELIZABETH, RICHARDS & PARTITION STS.
Office, 88 Van Dyke St., Brooklyn, N. Y.

LACLEDE FIRE BRICK MFG. CO.,
MANUFACTURERS OF
Fire Brick, Gas Retorts,

AND
ST. LOUIS STANDARD SEWER PIPE.
Blast Furnace and Cupola Linings, every description of Fire
Clay Material, Fire Clay Flue Linings, Chimney Tops
Dry Milled and Crude Fire Clays, etc.
OFFICE AND DEPOT
901, 903, and 905 Pine Street,
ST. LOUIS, MO.

ESTABLISHED IN 1845.
B. KREISCHER & SONS,
OFFICE FOOT OF HOUSTON ST., E. R., N. Y.
Gas Retorts,
TILES, FIRE BRICK.
AND EVERYTHING IN THE FIRE CLAY LINE.

MANHATTAN
FIRE BRICK & ENAMELLED CLAY
RETORT WORKS
ADAM WEBER.

CLAY GAS RETORTS
AND RETORT SETTINGS
FIRE BRICKS, TILES, ETC.,
Office and Works, 15th Street and Avenue C., N. Y.

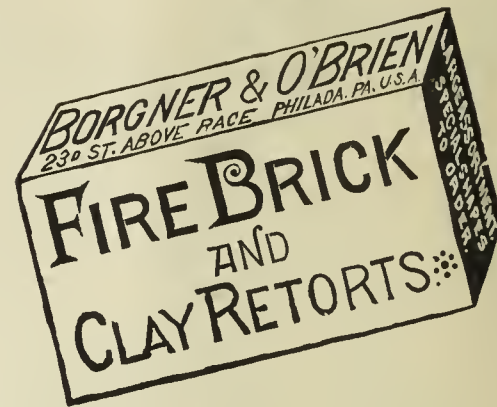

Works,
LOCKPORT STATION, PA.

—ESTABLISHED 1864.—

JAMES GARDNER, JR.,

Office, Rooms 19 & 20, Lewis Block,
PITTSBURGH, PA, P. O. Box 373.

Successor to WILLIAM GARDNER & SON.

Fire Clay Goods for Gas Works.

CHAS. H. SPRAGUE & SON, No. 70 KILBY STREET, BOSTON, MASS., Agents for the New England States.

GEO. C. HICKS, Prest. **CHICAGO** CHAS. A. REED, Sec. & Treas.
Retort and Fire Brick Co.,
MANUFACTURERS OF
Fire Clay Goods of all Kinds,
AND BEST QUALITY ONLY.
Regenerative Furnaces & Water Gas Goods.
45th St., Clark to La Salle, Chicago.

GEROULD'S IMPROVED RETORT CEMENT.
A Cement for patching retorts, putting on mouthpieces, and
making up all bench-work joints. This Cement is mixed ready
or use. Economic and thorough in its work. Fully warranted
o stick. For recommendations and price list address
C. L. GEROULD & CO.,
5 & 7 Skillman St., Brooklyn, N. Y.
Western Agent, H. T. GEROULD, Mendota, Ill.

Parker-Russell
Mining and Mfg. Co.,
CITY OFFICE: { Merrimod-Jaccard Bldg., Rooms 307 & 308,
Broadway and Locust Street, St. Louis, Mo.
PROPRIETORS OF THE
OAKHILL GAS RETORT & FIRE BRICK W'KS

Our immense establishment is now employed almost entirely in
the manufacture of materials for
GAS COMPANIES.
We have studied and perfected three important points. Our re-
torts are made to stand changes of temperature, the strongest
heats of the furnace, and the abrasion of feeding and emptying.
We furnish and build Half-Depth or Full
REGENERATOR FURNACES
of different kinds and most approved styles.
Correspondence solicited.

THOS. SMITH, Prest. AUGUST LAMBLA, Vice-Prest. & Supt.
BALTIMORE
RETORT & FIRE BRICK CO.
MANUFACTORY AT
LOCUST POINT, BALTIMORE, MD.

Clay Retorts, Blocks & Tiles,
FIRE BRICK, FIRE CLAY,
AND FIRE CEMENT.
Red and Buff Ornamental Tiles and Chim-
ney Tops. Drain and Sewer Pipe (from
2 to 30 inches). Baker Oven Tiles
12x12x2 and 10x10x2.
WALDO BROS., 88 WATER ST., BOSTON, MASS.
Sole Agents the New England States.

1889 DIRECTORY 1889

OF THE GAS LIGHT COMPANIES of the UNITED STATES & CANADA.

Price, \$3.00.

A. M. CALLENDER & CO., No. 42 Pine Street, N. Y. City.

HENRY MAURER & SON,
 (ESTABLISHED 1858.)
EXCELSIOR FIRE BRICK & CLAY
RETORT WORKS
 WORKS, Perth Amboy, N. J.
 OFFICE, 418 to 422 East 23d St., N. Y.
Clay Gas Retorts,
BENCH SETTINGS,
 Fire Brick, Tiles, Etc.

FLEMMING'S
Generator-Gas Furnace

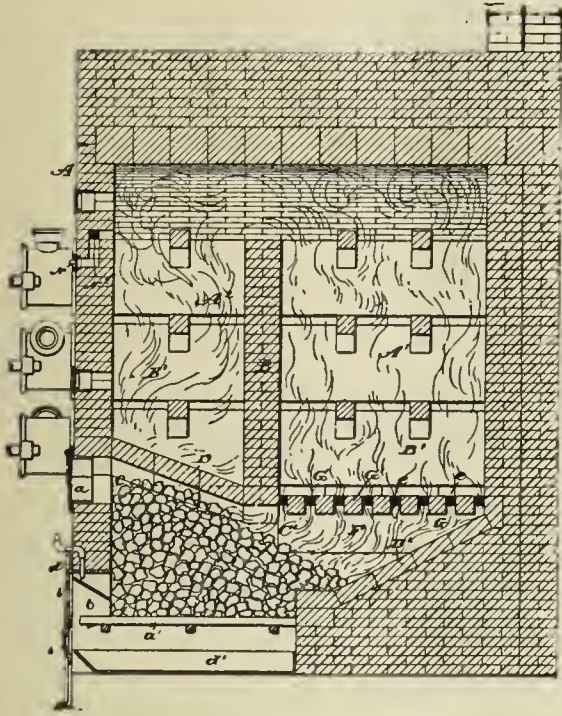

Materials furnished and Benches erected by

J. H. GAUTIER & CO., - Jersey City, N. J.
 Address as above, or D. D. FLEMMING, Jersey City, N. J.

FRED. BREDEL,
 CONTRACTOR FOR THE COMPLETE
Erection and Equipment of Gas Works,
 SOLE PROPRIETOR OF THE
KLOENNE PATENTS
 FOR NORTH AMERICA.

REGENERATIVE FURNACES.

(900 Retorts are now fired in America by the Kloenne-Bredel System.)

SELF-SEALING MOUTHPIECES.

(Over 800 Now in Use.)

Standard Condensers. Washer-Scrubbers.

TAR WASHERS FOR WATER GAS PLANTS.

(In use in the works of the Chicago Gas Lt. Co.)

GASHOLDERS.

Bredel's Automatic Gas Governor.

Refers, by permission, to Mr. Eugene Vanderpool, Newark, N. J.; Mr E. G. Cowdery, Milwaukee, Wis.; and Mr. Theo. Forstall, Chicago, Ills. For further information, address

FRED. BREDEL,
No. 208 East Seventeenth Street, N. Y. City.

THE BRENNER SELF-SEALING RETORT DOOR.

Simple, Strong, and Durable.

CLOSES ABSOLUTELY TIGHT & IS LOCKED BY A CAM LEVER. ALL NECESSARY ADJUSTMENT FOR WEAR PROVIDED.

BUILT BY

SMITH & SAYRE MFG. CO.,
No. 245 Broadway, - - - New York City.

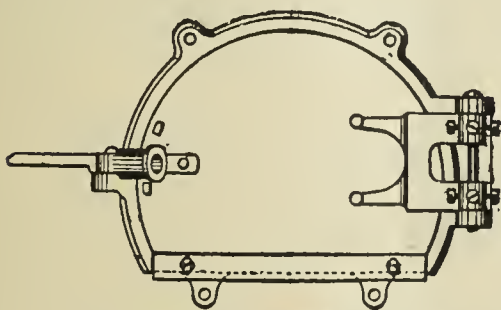

Brenner Self-Sealing Retort Door.

WILLIAM B. LUNDIE, Superintendent of the 42d Street Station of the Consolidated Gas Company, of New York, writes, under date of Jan. 4, 1889:

"We have 320 Brenner Self-Sealing Lids in use at this Station, built by the Smith & Sayre Mfg. Co. They require very little attention, and are the best of the kind that I have seen, giving entire satisfaction."

GREENOUGH'S
"DIGEST OF GAS LAW."
 Price, \$5.00.

This is a valuable and important work, a copy of which should be in the possession of every gas company in the country, whether large or small. As a book of reference it will be found invaluable. It is the only work of the kind which has ever been published in this country, and is most complete. Handsomely bound. Orders may be sent to

A. M. CALLENDER & CO.,
42 Pine Street, N. Y.

GAS vs. ELECTRIC LIGHT.

We would invite attention to the able and exhaustive argument of General A. Hickenlooper, President of the Cincinnati Gas Light and Coke Company, contained in a handsome pamphlet of 96 pages, entitled "EDISON'S INCANDESCENT ELECTRIC LIGHTS FOR STREET ILLUMINATION. REPORT OF AN ARGUMENT DELIVERED BY A. HICKENLOOPER BEFORE THE COMMITTEE ON LIGHT, MUNICIPAL COUNCIL, CITY OF CINCINNATI, JULY 22, 1886."

This is a subject of special interest to all Gas Light Companies.

Prices.

25 copies.....	\$7.50	100 copies.....	\$22.50
50 copies.....	12.50	250 copies.....	50.00

A sample copy will be sent by mail on receipt of 50 cts. **A. M. CALLENDER, & CO., 42 PINE ST., N. Y. CITY.**

BOOKS.

DISTILLATION OF COAL TAR AND AMMONIACAL LIQUOR.

By GEORGE LUNGE. Price \$12.50.

A TREATISE ON THE COMPARATIVE COMMERCIAL VALUES OF GAS COALS AND CANNELS.

By DAVID A. GRAHAM. 8vo., Cloth. Price \$3.

Orders for these books may be sent to this office.

A. M. CALLENDER & CO.,

42 PINE ST., N. Y. CITY

GAS AND WATER PIPES.

GAS AND WATER PIPES.

ENGINEERS.

SAM'L R. SHIPLEY, Pres.
HENRY B. CHEW, Tre

JAS. P. MICHELLON, Sec.
WM. SEXTON, Supt.

P. D. WANNER, Chairman. A. H. MELLERT, Mangr. of Wk
R. B. KINSEY, Secretary. F. A. KNOPP, Treasurer.

GLOUCESTER IRON WORKS,
GLOUCESTER CITY, N. J.



Cast Iron Gas & Water Pipes, Stop Valves, Fire Hydrants, Gasholders. &c.

Office, Rooms 61 and 63 Bullitt Building, 131 S. 4th St., Phila., Pa.

MELLERT FOUNDRY & MACHINE CO. Ltd.
and **READING FOUNDRY CO., Ltd.,**
Reading, Pa.



Specials—Flange Pipe, Valves and Hydrants
Lamp Posts, Retorts, etc.

General Foundry and Machine Work.
JOHN FOX, Selling Agent. 160 Broadway, N.Y.

THE OHIO PIPE COMPANY,

MANUFACTURERS OF

Cast Iron Gas & Water Pipe,
BRANCH AND SPECIAL CASTINGS.

Gas-House Bench Castings, Hydraulics, Lamp Posts, Flange Pipe
and Specials, Architectural Castings, Building Columns,
Joists, Cellar Grates, Sash Weights, etc.

GENERAL FOUNDERS AND MACHINISTS.
Columbus, Ohio.

M. J. DRUMMOND,



SPECIAL CASTINGS AND LAMP POSTS.
Office, Corbin Building, 192 Broadway, N. Y.

EMAUS PIPE FOUNDRY.
DONALDSON IRON COMPANY. EMAUS, PA.



MANUFACTURERS OF
CAST IRON PIPE AND SPECIAL CASTINGS
FOR WATER AND GAS.

JOS. R. THOMAS,

No. 42 Pine Street, N.Y. City.

CONSULTING AND CONSTRUCTING
Gas Engineer and Contractor.

PLANS, SPECIFICATIONS, AND ESTIMATES
FURNISHED.

Contracts taken for all Appliances
required at a Gas Works,
Either for New Works or Extensions to Old Plants.

WM. MOONEY

(Successor to WM. FARMER)

No. 94 Liberty St., N. Y. City.

GAS ENGINEER AND CONTRACTOR FOR THE ERECTION
OF GAS WORKS, OR APPARATUS OF ANY
CAPACITY.

Plans and Specifications Furnished.

WM. GARDNER,
Gas Engineer,

Lewis Block, Room 20, Pittsburgh, Pa.

Those who intend to make alterations in existing gas plants, or
who contemplate the erection of new works, will find it to their
interest to open correspondence with the above. Plans mad
and estimates furnished.

WARREN FOUNDRY AND MACHINE CO.,

Established 1856. Works at Phillipsburgh, N. J.

New York Office, 160 Broadway.

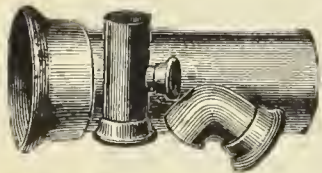

CAST IRON WATER AND GAS PIPE,

FROM TWO TO FORTY-EIGHT INCHES DIAMETER. ALSO, ALL SIZES OF

Flange Pipe for Sugar House and Mine Work. Branches, Bends, Retorts, etc., etc.

DENNIS LONG & COMPANY,

LOUISVILLE, KY.,



CAST IRON GAS & WATER PIPE & SPECIAL CASTINGS
OF ALL SIZES.

King's Treatise on Coal Gas.

A standard text-book for the Engineers and Managers of Gas Works, and for all who are concerned
or take an interest in the manufacture and distribution of Coal Gas, and in the utilization of the
Secondary Products resulting therefrom; treating also of the Gas Engine, and of Gas Cooking and
Heating Appliances.

In 3 Vols. Price per Vol., \$10. Sold either by Volume or in Sets.

A M. CALLENDER & CO., 42 Pine St., N. Y.

BARTLETT, HAYWARD & CO.

Baltimore, Md.

Triple Double, & Single-Lift
GASHOLDERS.

Iron Holder Tanks.

ROOF FRAMES.

Cirders.

BEAMS.

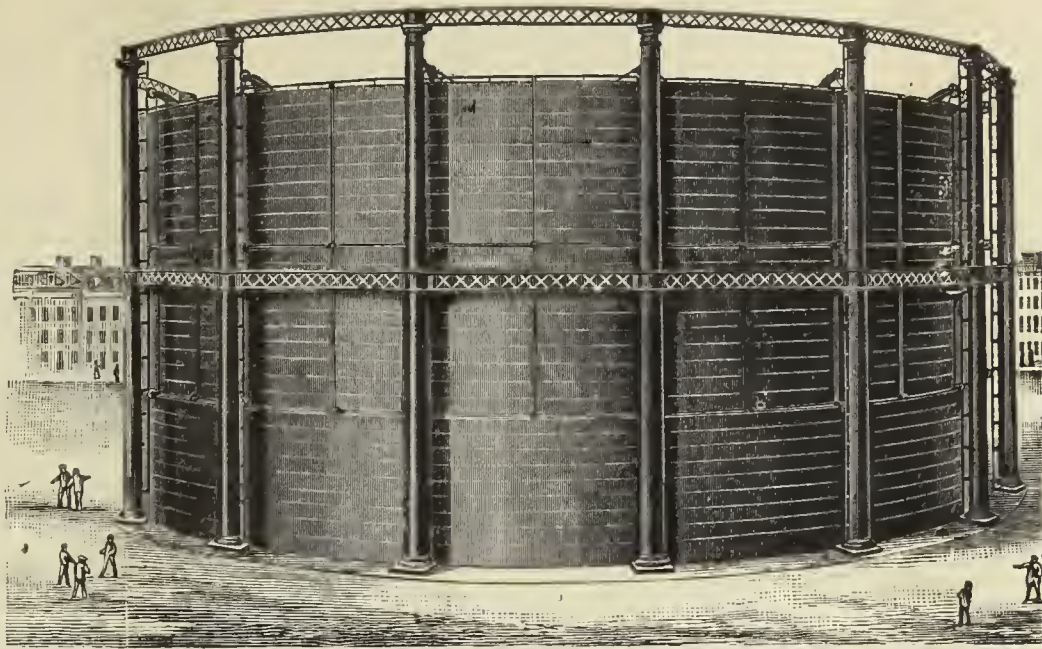

PURIFIERS.

CONDENSERS.

Scrubbers.

BENCH CASTINGS.

OIL STORAGE TANKS.

Boilers.

The Wilkinson Water Gas Process.

THIRTY-CANDLE, NON-CONDENSABLE, FIXED GAS. THE MOST SUCCESSFUL GAS PROCESS IN OPERATION.

Munich Regenerative Furnace, System Drs. Schilling & Bunte.

HAZELTON BOILERS.

Gas Works Designed and Constructed.

Pascal Iron Works. ESTABLISHED 1821. Delaware Iron Works.

MORRIS, TASKER & CO.,

INCORPORATED.

OFFICE, 224 SOUTH THIRD STREET, - - PHILADELPHIA, PA.

CONTRACTORS, BUILDERS, AND MANUFACTURERS OF

Gas, Water & Sugar Works

Bench Castings.

Condensers.

Scrubbers.

Purifiers.

Hyd. Carriages.

Iron Floors,

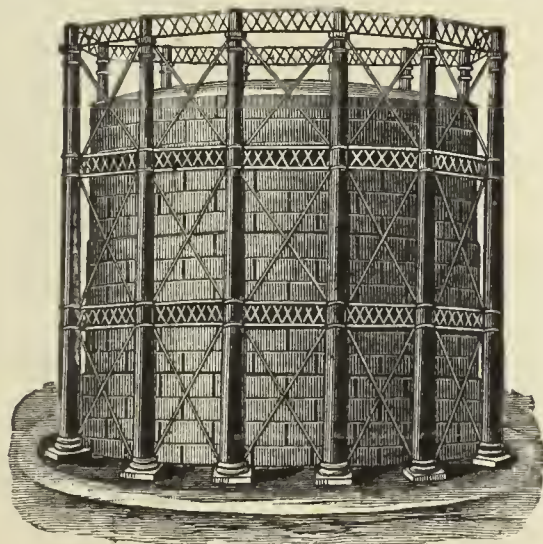

Iron Roofs.

Street Stops,

Valves, etc.

Stand-Pipes.

Water & Oil

Tanks, all Sizes.

Single, Double, and Triple-Lift Gas Holders.

SELF-SEALING RETORT LIDS. STAMPED STEEL RETORT LIDS.

Locomotive Water Columns, Filters, etc. Boiler Tubes, Wrought Iron Pipe & Fittings

Plans, Specifications and Estimates for all kinds of Machinery furnished on application.

Foundries & Works,
MILLVILLE, FLORENCE,
and CAMDEN, N. J.

R. D. WOOD & CO.,

Engineers,
Iron Founders,
and
Machinists.

400 Chestnut St., PHILADELPHIA, PA.

MANUFACTURERS OF

CAST IRON PIPE,

Gas Holders,

SINGLE, DOUBLE, AND TRIPLE LIFTS, WITH
OR WITHOUT WROUGHT IRON
OR STEEL TANKS.

PURIFIERS, CONDENSERS.

Scrubbers.

BENCH WORK.

Iron Floors and Roofs, Plate Girders.

Heavy Loam Castings.

HYDRAULIC WORK.

Lamp Posts, Valves, Etc.

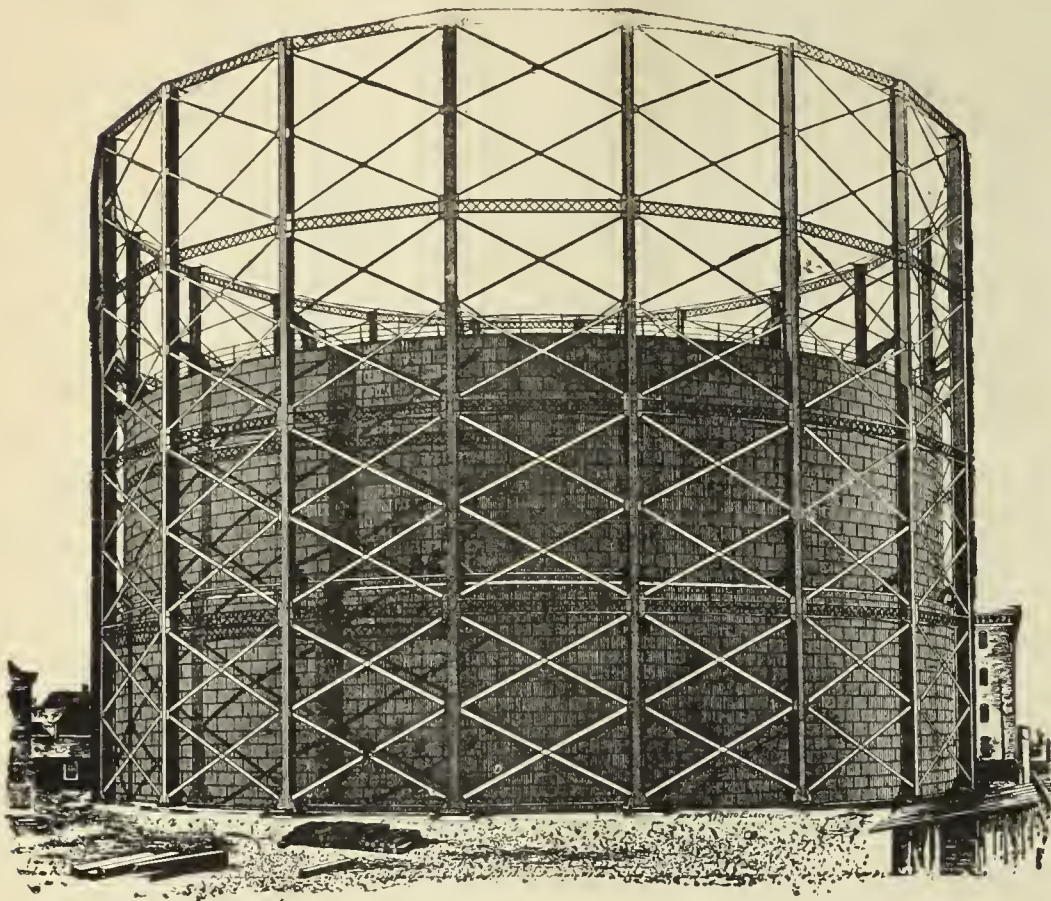

ROOTS' NEW GAS EXHAUSTER.

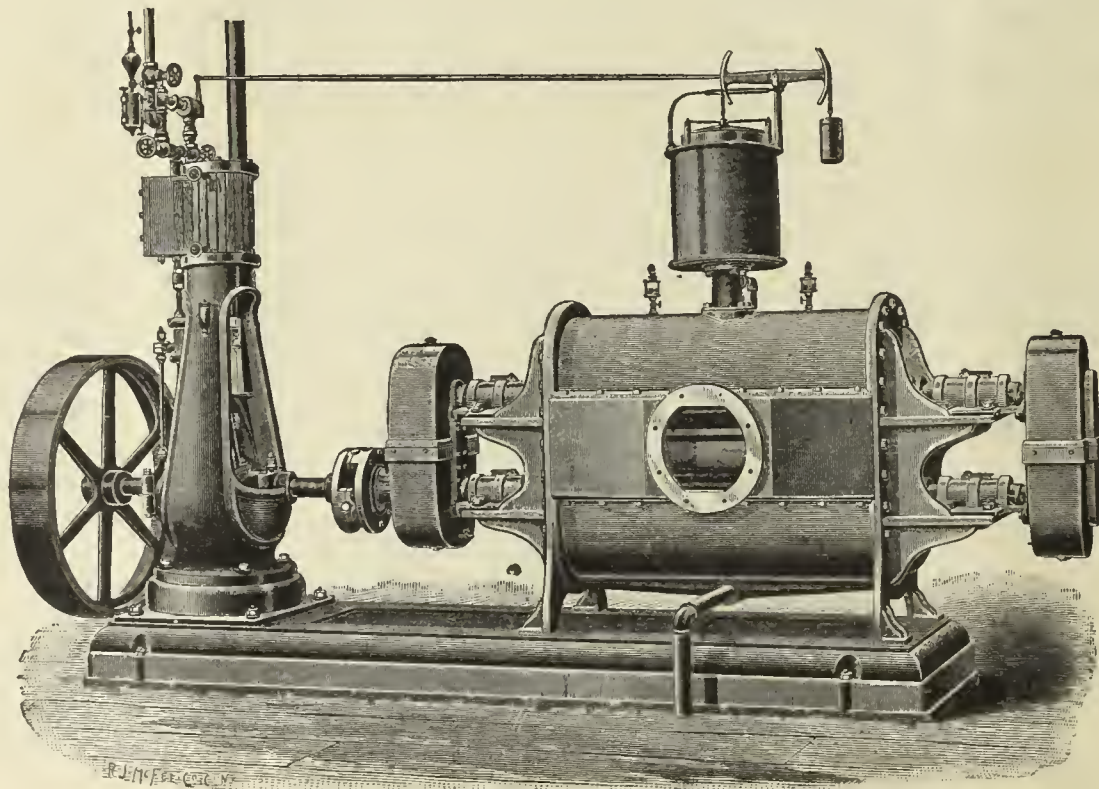

CONSTRUCTED ON ENTIRELY NEW PRINCIPLES.

THE ONLY EXHAUSTER MADE WHERE

The Parts Needing Attention are External and Easily Accessible.

Send for Descriptive Catalogue and Price List.

P. H. & F. M. ROOTS, Patentees and Manufacturers, CONNERSVILLE, IND.

S. S. TOWNSEND, Gen. Agt., 22 Cortlandt St., N. Y. COOKE & CO., Selling Agts., 22 Cortlandt St., N. Y.

GAS WORKS APPARATUS AND CONSTRUCTION.

GAS WORKS APPARATUS AND CONSTRUCTION.

JAMES R. FLOYD & SONS,

(SUCCESSORS TO HERRING & FLOYD)

Oregon Iron Works,

W. 20th & 21st. Sts., bet. 10th & 11th Avs.,

NEW YORK CITY.

Engineers and Contractors

FOR THE

CONSTRUCTION OF GAS WORKS.

MANUFACTURERS OF

All Kinds of Castings and General Ironwork

FOR

GAS APPARATUS.

Bench Castings, Regenerative and Half Regenerative Furnace Castings.

Condensers, Scrubbers, Purifiers, Street Drips and Connections, **Valves,**

Hydraulic Hoisting Purifier Carriage, Self-Sealing Retort Lids, Improved Valve Stand and Indicator, Seller's Cement.

Plans, Specifications, and Estimates furnished for Construction of New or Alteration of Old Works.

CONTINENTAL IRON WORKS.

THOS. F. ROWLAND, Prest.

WARREN E. HILL and CHAS. H. CORBETT, V-Prests.

THOS. F. ROWLAND, JR., Sec. & Tr

P. O. Station G., BROOKLYN, N. Y.

ENGINEERS AND MANUFACTURERS OF

Gas Holders

CONDENSERS, SCRUBBERS, VALVES,

PURIFIERS, SELF-SEALING RETORT LIDS.

Hydraulic Mains,

And all other articles connected with the manufacture and distribution of Gas.



H. RANSHAW, Prest. & Mangr.

WM. STACEY, Vice-Prest.

T. H. BIRCH, Asst. Mangr.

R. J. TARVIN, Sec. & Treas.

STACEY MFG. CO.,

MANUFACTURERS OF

Single and Telescopic Gasholders,

IRON ROOFS, BRIDGES, LAMP POSTS,

Water and Oil Tanks, Coal Elevator Cars,

COKE CRUSHERS, BENCH CASTINGS,

And all kinds of Wrought and Cast Iron Work used in the erection of Coal and Oil Gas Works Rolling Mill Machinery and Heavy Castings a Specialty.

Foundry:

33, 35, 37 & 39 Mill Street.

Wrought Iron Works:

16, 18, 20, 22, 24 & 26 Ramsey Street:

Cincinnati, Ohio.

Bouton Foundry Co.,

FOUNDERS AND MACHINISTS,

CHICAGO, ILL.

Gas Works Apparatus,

PURIFIERS, CONDENSERS,

Bench Work

SPECIALS, LAMP POSTS,

SCRUBBERS,

Iron Roofs and Floors.

Plans and Estimates furnished for new works or extensions of old works.

1842. **DEILY & FOWLER,** 1889.

Laurel Iron Works.

Address, No. 39 Laurel Street, Philadelphia, Pa.

BUILDERS OF

GASHOLDERS,

Single and Telescopic.

HOLDERS BUILT 1884 TO 1888, INCLUSIVE:

- | | | | | |
|----------------------------|-----------------------------|---------------------------|--------------------------|------------------------|
| Newport, R. I. | Long Island City, N. Y. | Port Chester, N. Y. | Malden, Mass. | West Chester, Pa. (2d) |
| Portland, Oregon. | Macon, Ga. | New Rochelle, N. Y. | Paducah, Ky. | Lancaster, Pa. (3d) |
| Allegheny, Pa. (2d.) | York, Pa. | Salem, N. J. (3d) | Norwich, Conn. | Tacony, Pa. (two) |
| Atlanta, Ga. (2d.) | Chester, Pa. | Omaha, Neb. (2d) | Seattle, W. T. | Mount Vernon, N. Y. |
| N.Y. City (Central Gas Co) | Hazleton, Pa. (2d.) | Lynn, Mass. (2d) | San Diego, Cal. | Binghamton, N. Y. |
| Lynchburg, Va. (2d.) | Staten Island, N. Y. | Little Rock, Ark. | Northern Gas Lt. Co., of | Concord, N. H. |
| Saylesville, R. I. | Saugerties, N. Y. | Irvington, N. Y. | New York, N. Y. | Dover, Del. (2d) |
| Rondout, N. Y. | Clinton, Mass. (Lan. Mills) | South Boston, Mass. | Westerly, R. I. | Calais, Me. |
| Atlantic City, N. J. | Chattanooga, Tenn. | Rye, N. Y. (2) | Willimantic, Conn | New London, Conn. (2d) |
| Augusta, Ga. | Galveston, Texas. (3d.) | Woodstock, Ont. | Montclair, N. J. | West Chester, N. Y. |
| Waltham, Mass. (2) | Omaha, Neb. | Malden, Mass. | Attleboro, Mass. | Bay Shore, L. I. |
| Mahanoy City, Pa. | Fort Plain, N. Y. | Staten Island, N. Y. (2d) | Santa Cruz, Cal. | Washington, D. C. |
| New Castle, Pa. | Brunswick, Ga. | Woodstock, Ont. | Erie, Pa. (2d) | |

SMITH & SAYRE MFG. COMPANY,

G. G. PORTER, Prest.

245 Broadway, N. Y.

CHAS. W. ISBELL, Sec'y.

Machinery & Apparatus for Gas Works

Drawings, Plans, and Estimates Furnished for the Improvement, Extension, or Alteration of Gas Works, or for the Construction of New Works.

Mackenzie's Patent Rotary and Steam Jet Gas Exhausters, Governors, Compensators, Condensers, Washers, Scrubbers. Isbell's Patent Automatic Street Pressure Governor, Gas and Water Valves, Hydraulic Main Dip Regulator, Bench Castings, etc. Purifying Boxes and "Standard" Scrubbers Isbell's Patent Self-Sealing Retort Doors.

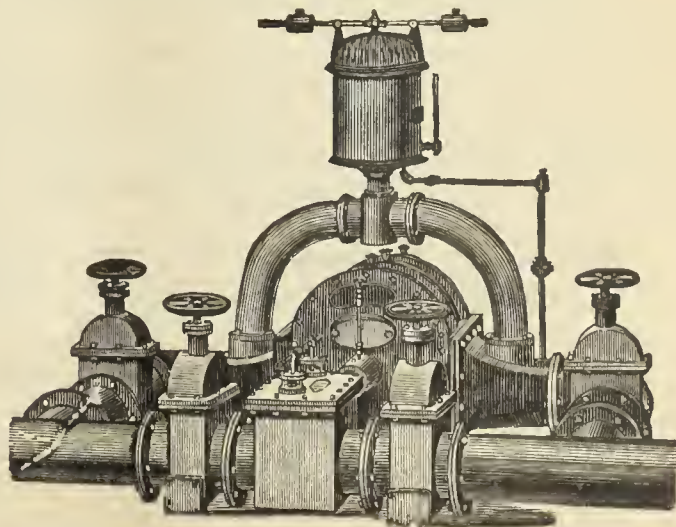

GAS COALS.

CANNEL COALS.

GAS ENRICHERS.

JAMES D. PERKINS. **PERKINS & CO.,** F. SEAVERNS.
 228 & 229 Produce Exchange, New York.
 Cable Address, "PERKINS, NEW YORK." Post Office Box 3695, New York.

GENERAL SALES AGENTS FOR

The Youghioghenny River Coal Company's
OCEAN MINE YOUGHIOGHENY GAS COAL.

HON. W. L. SCOTT, Prest. M. H. TAYLOR, Vice-Prest.

This Colliery is located at SCOTT HAVEN, PA., in the center of the Youghioghenny Gas Coal District, and produces the ONLY RELIABLE YOUGHIOGHENY COAL for gas purposes. (See Map on p. 87 of this JOURNAL, Feb. 16, '85.)

POINTS OF SHIPMENT,

Locust Point, BALTIMORE. Pier No. 62, PHILADELPHIA.

Also, SOLE AGENTS for the

BRECKENRIDGE CANNEL,
OF KENTUCKY.

Within the past two years we have delivered this Cannel to over ONE HUNDRED COMPANIES IN THIRTY-THREE DIFFERENT STATES, and it is now in use in some of the large Gas Works

On the Continent and in South America,

where it successfully competes with the Australian Shale. It is the ONLY AMERICAN GAS CANNEL of sufficiently high grade to warrant EXPORTATION TO EUROPE AND SOUTH AMERICA, and it is the only economical substitute for OIL OR NAPHTHA. ONE GROSS TON will produce

10,000 Cubic Feet of 75 Candle Gas,	} equal to {	750,000 Candle Feet of Gas, and 26 Bushels of merchantable Coke weighing 900 Pounds
or 12,500 " " 60 " "		
or 15,000 " " 50 " "		

This is the ONLY GAS CANNEL that will produce a REALLY MERCHANTABLE COKE. It can be delivered in parcels of one carload or more to any point in the United States or Canada. Cargo shipments of any size required can be made from NEW YORK, PHILADELPHIA, BALTIMORE, or NEWPORT NEWS. Samples will be sent and particulars of price, etc., forwarded upon application to above address.

JAMES & WILLIAM WOOD,
Gas and Cannel Coal Contractors,

No. 40 St. Enoch Sq., Glasgow. No. 2 Talbot Court, London.

Proprietors of the BATHVILLE COLLIERIES (which produce the celebrated BOGHEAD CANNEL), Shields, Shieldmuir, Drumpeller, and other Collieries. This Firm offer

STANDARD CANNELS,

Unequaled as Gas Enrichers.

Also, WEST FAIRMONT GAS COAL, of W. Va.

Analyses, prices, and all further information furnished on application to

Agency for U.S., Room 93, Nos. 2 & 4 Stone St., N.Y. City

The Standard Oil Company,

REFINERS OF

NAPHTHA AND GASOLINES.

ALSO MANUFACTURERS OF

A Special Grade of Naptha for
 Gas Companies

FOR ENRICHING COAL GAS.

Correspondence solicited.

No. 43 Euclid Avenue, Cleveland, Ohio.

To Gas Companies.

We make to order CAP BURNERS to burn any amount under a stated pressure. Send for samples.

Also, SERVICE CLEANERS, DRIP PUMPS, and STREET MAIN PROVING APPARATUS.

E. A. GEFROER,

248 N 5th Street, Phila., Pa.

COKE CRUSHERS.

GAS COALS.

GAS COALS.

Newburgh Orrel Coal and Coke Co.

MINERS AND SHIPPERS OF
STEAM, SMITHING, AND GAS COALS,
Foundry and Crushed Coke.

Home Office, 33 S. Gay Street, Baltimore, Md.

CHAS. MACKALL, Gen. Mangr.
CHAS. W. HAYS, Agent, No. 1 Broadway, N. Y.
Shipping Wharves, Locust Point, Baltimore.

The Despard Gas Coal Co.,

MINERS AND SHIPPERS OF
DESPARD GAS COAL,

AND MANUFACTURERS OF
COKE.

MINES, Clarksburg, Harrison Co., W. Va.

WHARVES, Locust Point, Baltimore, Md.

OFFICE, 225 E. German St., " "

ROUSSEL & HICKS, } AGENTS. } BANGS & HORTON,
71 Broadway, N. Y. } 60 Congress St., Boston.

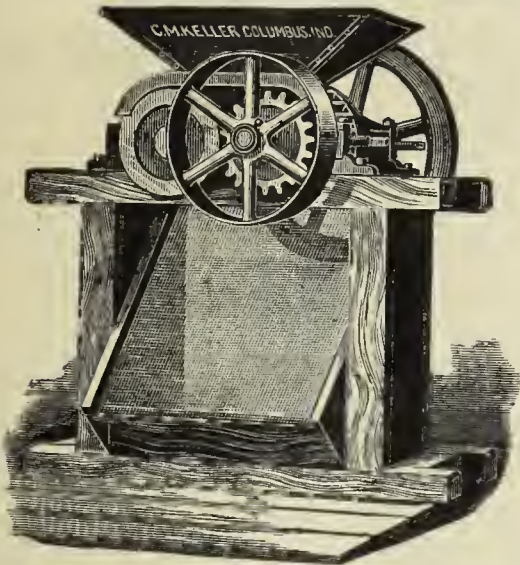

Keller's Adjustable Coke Crusher.

SIMPLE, STRONG, AND DURABLE.

O. M. Keller, Sec. & Supt. Gas Lt. & Coke Co. Columbus, Ind.

Correspondence Solicited.

King's Treatise on Coal Gas.

The most complete work on Coal Gas ever published.

Three Vols. Bound, \$30.

THE
PENN GAS COAL CO.

OFFER THEIR

Coal, Carefully Screened & Prepared for Gas Purposes.

Their Property is located in the Youghiogheny Coal Basin, near Irwin and Penn Stations on the Pennsylvania Railroad, and on the Youghiogheny River.

Principal Office:

209 SOUTH THIRD STREET, PHILA., PA.

Points of Shipment:

Pennsylvania Railroad Piers; Greenwich Wharves, Delaware River; Pier No. 1 (Lower Side), South Amboy, N. J.

Chesapeake & Ohio Railway Coal Agency,

FOR THE SALE OF THE

Superior Kanawha Gas Coals, Cannelton Cannel,
Also, SPLINT AND STEAM COALS,

From the Kanawha and New River Regions, on the line of the Chesapeake & Ohio R'way.

C. B. ORCUTT, General Agent, - - No. 1 Broadway (Room 217) New York City.

FRANCIS H. JACKSON, Prest. EDMUND H. MCCULLOUGH, V.-Prest. CHAS. F. GODSHALL, Treas. H. C. ADAMS, Sec.

THE WESTMORELAND COAL CO.

Chartered 1854.

Mines situated on the Pennsylvania and the Baltimore and Ohio Railroads, in Westmoreland County, Penn.

POINTS OF SHIPMENT:

PHILADELPHIA, BALTIMORE, SOUTH AMBOY, N. J.,
WATKINS (SENECA LAKE), N. Y.

Since the commencement of operations by this Company its well-known Coal has been largely used by the Gas Companies of New England and the Middle States, and its character is established as having no superior in gas-giving qualities, and in freedom from sulphur and other impurities.

Principal Office, 224 South 3d St., Phila., Pa.

WM. HENRY WHITE,

No. 32 Pine Street, - - - New York City.

ENGINEER AND CONTRACTOR FOR THE

Erection and Extension of Gas, Water, and Electric Light Works.

SOLE REPRESENTATIVE OF THE

McILHENNY REGENERATOR FURNACE PATENTS

And the Martin Water Gas Process.

Edison Incandescent and American Arc Electric Light Plants Installed.

Correspondence with Gas Companies contemplating extending or improving their Plants respectfully invited.
Plans and Estimates Furnished.

GAS METERS.

GAS METERS.

GAS METERS.

JOHN J. GRIFFIN & CO.,

Gas Meter Manufacturers,

Philadelphia, New York
and Chicago,

Will Occupy this Space Hereafter.

NATHANIEL TUFTS,

No. 153 Franklin Street, Boston, Mass.,

MANUFACTURER OF

DRY GAS METERS.

Station Meters of any Capacity.

Test and Experimental Meters, Pressure Registers, Pressure Gauges,
Pressure and Vacuum Gauges.

METER PROVERS, PHOTOMETERS, STREET LANTERNS, ETC., ETC.

Patent Cluster Lanterns for Street Illumination.



Dry Gas Meters.

With 40 years' experience and the best facilities for manufacturing, is enabled to furnish reliable work and answer orders promptly.

250 & 252 Pearl Street, **JOHN HILLEN'S BROOKLYN GAS METER WORKS.** BROOKLYN, N. Y.

MANUFACTURER OF

IMPROVED GAS METERS

REPAIRING OF METERS (of all makers) a specialty. All defective working parts are replaced without extra charge. A guarantee is given with all work sent from this shop. Write for Price List.

CHARLES E. DICKEY.

JAMES B. SMALLWOOD.

CHARLES H. DICKEY.

THE MARYLAND METER AND MANUFACTURING CO.

Established 1866.

BALTIMORE, North & Saratoga Sts.

CHICAGO, 197 Michigan Street.

NEW YORK, 766 Broadway.

BOSTON, 4 Central Street.

ST. LOUIS, 1115 Olive Street.

SAN FRANCISCO, 330 Pine Street.

CONSUMERS' & STATION METERS, PRESSURE GAUGES, Etc., Etc.

"Success" and "Perfect" Gas Stoves.

SCIENTIFIC BOOKS. All books forwarded by express, upon receipt of price; if sent by mail, postage must be added to price given. We take pains in forwarding any other Works desired. Remittances by check, draft, or P.O. money order.

KING'S TREATISE ON THE MANUFACTURE OF COAL GAS. Three vols; \$10 per vol.

GAS MANUFACTURE, by WILLIAM RICHARDS. 4to., with numerous Engravings and Plates, in Cloth binding. \$12.

TECHNICAL GAS ANALYSIS. \$3.00.

GAS CONSUMER'S GUIDE. \$1.

A GUIDE TO GAS LIGHTING. 40 cents.

GAS MEASUREMENT AND GAS METER TESTING, by F. W. HARTLEY. \$1.60.

GAS CONSUMER'S HANDBOOK, by WILLIAM RICHARDS, C.E.: 18mo., Sewed. 20 cents.

A PRACTICAL TREATISE ON GAS AND VENTILATION, with Special Relation to Illuminating, Heating, and Cooking by Gas, by E. E. PERKINS. \$1.25.

PRACTICAL TREATISE ON HEAT, by THOMAS BOX. Second edition. \$5.

COAL; ITS HISTORY AND USE, by PROF. THORPE. \$3.50.

THE GAS WORKS OF LONDON, by COLBURN. 60 cents.

THE GAS FITTER'S GUIDE, Showing the Principles and Practice of Lighting with Coal Gas, by JOHN ELDRIDGE. 40 cents.

MUNICIPAL LIGHTING, by F. H. WHIPPLE. \$1.

GAS WORKS, AND MANUFACTURING COAL GAS, HUGHES. \$2.20.

THE MANAGEMENT OF SMALL GAS WORKS, by C. J. R. HUMPHREYS. \$1.

MANUAL FOR GAS ENGINEERING STUDENTS, by D. LEE. 40 cents.

HOW TO MANAGE GAS, by F. WILKINS. Paper. 20 cents.

THE DOMESTIC USES OF COAL GAS, AS APPLIED TO LIGHTING, by W. SUGG. \$1.40.

DISTILLATION OF COAL TAR AND AMMONIACAL LIQUOR, by GEO. LUNGE. New Edition. \$12.50.

ILLUMINATING AND HEATING GAS, by W. BURNS. \$1.50.

A TREATISE ON THE COMPARATIVE COMMERCIAL VALUES OF GAS COALS AND CANNELS, by D. A. GRAHAM, 8vo. Cloth. \$3.

GAS COMPANIES DIRECTORY. \$8.

GAS VERSUS ELECTRIC LIGHT. 50 cents.

THE AMERICAN GAS ENGINEER AND SUPERINTENDENT'S HANDBOOK, by WM. MOONEY. \$3.

DIGEST OF GAS LAW. \$5.

GAS ENGINE INDICATOR DIAGRAM, by W. E. AYRTON. Paper. 20 cents.

TESTING PIPES AND PIPE JOINTS, by M. M. PATERSON. 80 cents.

DESIGNING WROUGHT AND CAST IRON WORK, by H. ADAMS. Paper. Three parts, 60 cents each.

NOTES IN MECHANICAL ENGINEERING, by H. ADAMS. \$1.

STRAINS IN IRONWORK, by H. ADAMS. With plates. \$1.75.

GAS WORKS—THEIR ARRANGEMENT, CONSTRUCTION, PLANT, AND MACHINERY. \$8.

A. M. CALLENDER & CO., 42 Pine Street, New York.

GAS METERS.

GAS METERS.

GAS METERS.

GEO. J. MCGOURKEY, Prest.

WM. H. MCFADDEN, Vice-Prest. (Phila.)

WM. N. MILSTED, Gen. Supt. and Treas. (New York).

WM. H. DOWN, Sec.

THE AMERICAN METER CO.

WET AND DRY GAS METERS.

PRESSURE REGISTERS.

METER PROVERS.

STATION METERS.

PRESSURE & VACUUM REGISTERS.

PORTABLE TEST METERS.

EXHAUSTER GOVERNORS.

PRESSURE & VACUUM GAUGES.

EXPERIMENTAL METERS.

DRY CENTER VALVES.

CRESSON GAS REGULATORS.

AMMONIA TEST METERS.

GOVERNORS FOR GAS WORKS.

MARSLAND WATER METERS.

BAR & JET PHOTOMETERS.

Manufactories:

512 West 22d St., N. Y.

Arch & 22d Sts., Phila.

GAS STOVES.

SUGG'S "STANDARD" ARGAND BURNERS,

SUGG'S ILLUMINATING POWER METER,

Wet Meters, with Lizar's "Invariable Measuring" Drum.

Agencies:

177 Elm Street, Cincinnati.

244 & 246 N. Wells Street, Chicago.

810 North Second Street, St. Louis.

222 Sutter Street, San Francisco.

HELME & McILHENNY,

(Established 1848.)

GAS METER MANUFACTURERS,

Nos. 1339 to 1349 Cherry Street, Philadelphia, Pa.,

WET AND DRY GAS METERS, STATION METERS, EXPERIMENTAL METERS, METER PROVERS,

Center Seals, Pressure Registers, Governors, Indicators, Photometers, and all other kinds of Apparatus for use in Gas Works.

FOULIS' PATENT STATION AND DISTRICT GOVERNORS.

REPAIRING DEPARTMENT.—We employ a special force of skilled workmen repairing meters of all makers.

WM WALLACE GOODWIN, Prest. and Treas.

WM. H. MERRICK, Vice-Prest.

S. L. JONES, Sec.

S. V. MERRICK, Supt.

THE GOODWIN GAS STOVE AND METER CO.,

Successors to W. W. GOODWIN & CO.

1012, 1014 and 1016 Filbert St., Phila., Pa.

142 Chambers St., New York City.

76 Dearborn, St., Chicago, Ills.

WALDO BROTHERS, Agents, 88 Water Streets, Boston, Mass.

MANUFACTURERS OF

DRY AND WET GAS METERS,

Station Meters (square, cylindrical, or in staves), Glazed Meters, King's and Sugg's Experimental Meters, Lamp Post Meters, etc., etc. Meter

Provers (sizes 2, 5, and 10 feet), Pressure Gauges of all kinds, Pressure Registers, Pressure and Vacuum Registers, Pressure Indicators

(sizes 4, 6, and 9 inch), King's Pressure and Vacuum Gauges, Dry and Wet Center Seals, Dry and Wet Governors, Exhauster

Governors, Photometers of all descriptions. Lethby's Sulphur and Ammonia Test Apparatus complete. Also, Testing

and Chemical Apparatus of all kinds, and of the most perfect description, for all purposes relating to Gas.

Manufacturers of the "SUN DIAL" GAS STOVES, for Cooking and Heating.

Goodwin's Improved Lowe's Jet Photometer.

Agents for Bray's Patent Gas Burners and Lanterns.

Special attention to Repairs of Meters and all Apparatus connected with the business. All work guaranteed first-class in every particular. Orders filled promptly.

G. B. EDWARDS, Manager, New York.

S. S. STRATTON, Manager, Chicago.

D. MCDONALD & CO.,

GAS METER MANUFACTURERS.

(Established 1854.)

51 Lancaster St., Albany, N. Y. 34 & 36 West Monroe St., Chicago, Ill.

STATION METERS, EXPERIMENTAL METERS, METER PROVERS, PRESSURE & VACUUM REGISTERS, PRESSURE GAUGES, ETC

Also STAR GAS STOVES, RANGES, and HEATING STOVES.

We use only the very best materials, and employ the most skilled labor, and by our long experience (32 years) and personal supervision of every detail, we feel justified in assuring the public that our goods will give perfect satisfaction. Every Meter emanating from our establishment will bear the State Inspector's BADGE, and will be fully warranted by us. Our Annual and Calendar will be sent to Gas Companies upon application.

GAS STOVES.

GAS STOVES.

GAS STOVES.

THE GOODWIN GAS STOVE AND METER CO.,

1012-18 Filbert St., Phila., 142 Chambers St., N. Y., 76 Dearborn St., Chicago.

Agents, WALDO BROTHERS, 88 Water Street, Boston.

WM. W. GOODWIN, Pres. and Treas.
W. H. MERRICK, Vice-Pres.
S. LEWIS JONES, Sec.

SAMUEL V. MERRICK, Supt.
G. B. EDWARDS, Mang'r, N. Y.
S. S. STRATTON, Mang'r, Chicago.

SOLE MANUFACTURERS OF THE

"SUN DIAL" GAS STOVES,

The Most Economical, Efficient, and Durable Gas Stove Made.



GAS COOKING STOVE, No. 8 C.

SIZE.

Stove.	Oven.	Roaster.	Top.	Length over Extension Shelves.
37 in. high. 20 in. wide.	12 in. high. 17½ in. wide. 12 in. deep.	12 in. high. 18 in. wide. 13 in. deep.	24 in. long. 21 in. wide.	36 in.

This Stove has four burners on top, and double oven burner. Consumption of gas with all burners in use, 42 feet per hour, at 1 inch pressure. The top is made in sections, so that a greater variety of cooking utensils may be used. By lifting out the covers and crosspieces and putting in a suitable forked ring, which is sent with each stove, a wash boiler or other large utensil may be set over two burners. Our No. 87 GRIDDLE also fits in the same position. The roasting oven is provided with a cast-iron door.

All Fittings are Nickel-Plated.



GAS COOKING STOVE, No. 7 B.

SIZE.

Stove.	Oven.	Roaster.	Top.	Length over Extension Shelves.
31 in. high. 17 in. wide.	9½ in. high. 14½ in. wide. 12 in. deep.	10 in. high. 15 in. wide. 13 in. deep.	21 in. long. 16 in. wide.	32 in.

This Stove has three boiling burners in the Top or Hot Plate, and one single oven burner.

This cut represents our New Style Cooking Stove. As will be seen, it has an ornamented cast-iron Base and Front, and extension shelves. The Oven Burner, which is atmospheric (unless otherwise ordered), is of an entirely new and improved pattern (patent). The ovens are of greater capacity than those of the old style. The Top, in conjunction with the Outlet Pipe, is designed to carry off all the products of combustion, if desired, but they are also supplied with a loosering which converts it into an ordinary open top stove.

The consumption of this Stove is 35 cubic feet per hour at 1 inch pressure, with all Burners in use.

All Fittings are Nickel-Plated.

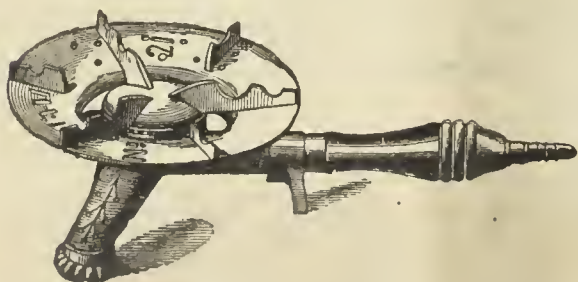

"RADIANT" BOILING STOVE, WITH REGENERATIVE BURNER.

Size, 6½ inches diameter, 3 inches high. Consumption, 6 cubic feet per hour at 1 in. pressure.

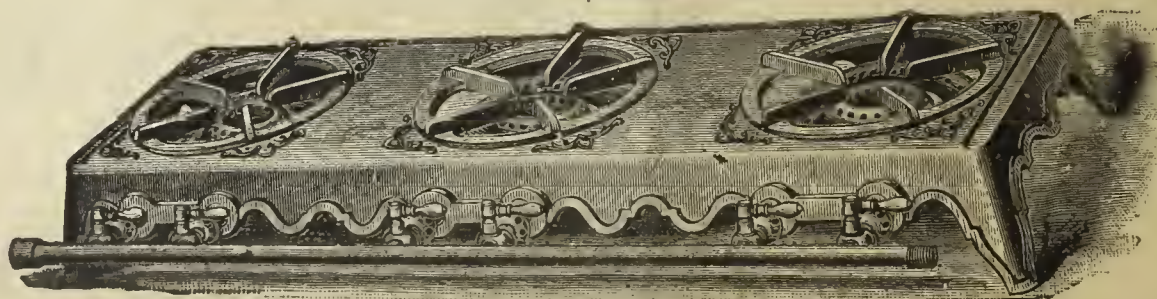

HOT PLATE, No. 111.

Size, 36 in. long, 12 in. wide, with three double burners, 6 taps. Consumption, with all burners in use, 36 cubic feet per hour, with 1 in. pressure. ½ in. supply pipe should be used where the pressure is 1 in. or over.

THE AMERICAN

GAS LIGHT JOURNAL

REDMAN & KENNY, N. Y.

PUBLISHING OFFICE NO. 42 PINE STREET

DEVOTED TO THE INTERESTS OF ILLUMINATION, VENTILATION, WATER SUPPLY AND DISTRIBUTION, & GENERAL SCIENCE.

VOLUME LII.—No. 2.
Whole No. 762.

NEW YORK, MONDAY, JANUARY 13, 1890.

{ \$3 PER ANNUM,
IN ADVANCE.

A. M. CALLENDER & CO., Proprietors. C. E. SANDERSON, Manager.
JOS. R. THOMAS, C. E., Editor. T. J. CUNNINGHAM, Asst. Editor.

ENTERED AT THE POST OFFICE AT NEW YORK, N. Y.
AS SECOND CLASS MATTER.

Published on each Monday of the year, at No. 42 Pine Street, N. Y.

Terms of Subscription, Including Postage.—For the United States and Canada, \$3 per annum. European countries, \$4.50 (19 shillings—22½ francs). All payments to be made in advance. Single copies, 10 cents.

CONTENTS.

An Asterisk (*) denotes an illustrated article.

EDITORIALS—

Briefly Told.....	37
Gas Stocks as Investments—An Old-New Firm—Annual Meeting, Lebanon, Pa.—Hints from Poughkeepsie, N. Y.—Will the Brush Company Carry out the Cincinnati Contract?—Annual Meeting, Fresno, Cal.—And Other Notes.	
Experiments on the Relation of Electric Lamps to Combustible Bodies.....	38
The Market for Gas Securities.....	38
The Chemistry of Illuminating Gas.....	39
*Carburetor for Gas Engines.....	40
*The Foulis Regenerative Furnace.....	41
The Deterioration of Electrical Conductors.....	41
*The Kusnezov Gas Washer.....	42
The Incandescent Light Controversy.....	42
Coke and Charcoal Compared.....	43
Chimney Proportion.....	44
Petroleum Market for 1889.....	44

ITEMS OF INTEREST FROM VARIOUS LOCALITIES..... 45

A Gas Inspector for Cleveland, O.—Free Turkeys—Consolidated at Fremont, O.—Public Lighting, Boston, Mass.—The Striking Stokers—Has the Council the Right to Regulate Gas Rates at Kansas City?—Gas Lamp Posts and Mail Boxes—Public Lighting, Denver, Col.—The Coroner's Verdict, Asheville (N. C.) Explosion—Public Lighting, Canton and Cleveland O.—Gas Stock at Auction—Public Lighting, East St. Louis, Mo.—Hints from Davenport, Ia.—Pleased with their Gas Engine—Annual Report, Supt. Public Lamps, Springfield, Mass—And Many Other Items.

[OFFICIAL NOTICE.]

New England Association of Gas Engineers.

SECRETARY'S OFFICE, BIRMINGHAM, CONN., Jan. 10, 1890.

The Twentieth Annual Meeting of the New England Association of Gas Engineers will be held at Young's Hotel, Boston, on Wednesday and Thursday, Feb. 19th and 20th. The meeting will be called to order on Wednesday, at 10 A. M., by the President, Mr. R. B. Taber.

At the present moment it is impossible to give a list of the papers which will be read at the meeting, but it is hoped that the literary part of the programme will equal any of those held in past years.

Persons eligible for membership who desire to join the Association will please communicate with the Secretary, who will forward at once blank form of application.

CHARLES H. NETTLETON, Sec'y.

BRIEFLY TOLD.

GAS STOCKS AS INVESTMENTS.—Following up our remarks of a week ago on the satisfactory increase in the gas business as shown from the records of the last twelvemonth, it is our present purpose to offer something further in confirmation of the fact that gas proprietors and gas makers share equally in the comfortable assurance that not only is their

joint dependence holding its own against all comers, but is again outstripping them, as in the days of about a decade ago. In the course of the past year we have collated from various reliable sources the opening and closing prices of gas shares at 87 different points in the country; and we think the result of the teaching disclosed by the figures is most convincing as to the upward tendency of this class of securities. The figures were obtained from places representative of all grades in respect to varying magnitude. That is, the Consolidated Company of this city, with its \$35,430,000 of capital, shares in the average with a small company in Illinois with a capital of less than \$20,000. The total capital figuring in the average is 62 millions of dollars. Of the 87 places noted a decrease in the value of the shares is found to have occurred in 5 instances—the average shrinkage being represented by 12½ points—while an increase, ranging from 2½ points to 35 points, is the result at the remaining localities about which inquiry was made. Spreading the averages over the entire value of the 62 millions, we find that the net average gain for the year (all these deductions are based on the market changes, on the "high and low" quotations for the year) was 11½ per cent., representing an increase in value for the twelvemonth of the snug sum of \$7,285,000. The average rate of dividend of these companies—excluding the Consolidated Company of this city, but admitting in the average 3 companies that did not pay any dividend—is shown to be 7.75 per cent. The dividend paid by the Consolidated Company for the year was 5 per cent., as against the 4 per cent. return made by it in 1888. The returns received go to show that Massachusetts gas shares are those which increase in value in the greatest relative proportion, and we may be forgiven for hinting that the method of State protection there followed is in no small degree responsible for the confidence manifested by investors. We would like to have it in our power to place before our readers these statistics in unmasked form, but as it was with our inquiries for sendout figures, so also was it with the request for the market valuation of shares—"the facts are so and so, but do not handle them so that our identity may be revealed." In any event, the figures, even though somewhat obscured, are nevertheless of a sort well calculated to dissipate any cloudy idea that gas shares do not continue to find favor with investors who value safety and progress as factors to determine them in the interest-earning disposition of their funds.

AN OLD-NEW FIRM.—It is probably no very great secret by this time that the Smith & Sayre Manufacturing Company has ceased to be, and that gas men are called to welcome its successor in the shape of the Isbell-Porter Company. Of course, the implied change is in reality no change at all, for both Messrs. Porter and Isbell have been the Smith & Sayre Company for years, and it is quite a certainty that they shall continue so for years to come. No change whatever is to be or has been made in the business of the firm, whose headquarters, as before, are to be at 245 Broadway, this city. We might, however, modify our statement in respect to the "no change whatever" clause by adding the qualifier that important changes are to be made on the Newark (N. J.) factories of the firm, which are to be greatly enlarged. This action had to be taken to enable the Company to keep easy pace between the reception and completion of contracts. The Company reports that the business outlook for 1890 is of the brightest sort.

THE METER COMPANY ANNUALS.—We are in receipt of copies of the annuals published by the Messrs. Helme & McIlhenny, of Philadelphia, the American Meter Company, and D. McDonald & Company, of Albany. We thought (and so said) last year that the meter men had about reached perfection in the arrangement and printing of their annuals, but that we were in error is easily discovered by a glance at the editions for this year. The lighting tables are as usual a feature of the books, and the supplementary pages are charts of information at once valuable and prettily arranged. The American Company's designer has brought out something novel in the way of a cover this year. The Helme & McIlhenny volume is notable for the fact that apart from its convenient pocket shape, it contains but $6\frac{1}{2}$ sheets devoted to advertising—this feature is not very prominent in any of the annuals now before us—and the McDonald specimen is notable particularly for the nice discrimination shown in editing the technical matter with which its pages abound. In their entirety the annuals are models of neatness, and there is little doubt that they will be eagerly sought for. Another thing in connection with the current editions that cannot help to attract the attention of the "old-timer" is the great disparity in their appearance when compared with the original volumes of some years ago. Of course, the difference is all in favor of the annual of to-day.

THE Parker-Russell Mining and Manufacturing Company, of St Louis, Mo., has been again awarded the annual contract for repairs and renewals to benchwork in both plants of the Cincinnati Gas Light and Coke Company.

ANNUAL MEETING, LEBANON, PA.—At the annual meeting of the Lebanon (Pa.) Gas Company (two-thirds of the stock being voted on) the following officers were chosen: President, Col. T. T. Worth; Secretary and Treasurer, John W. Mish; Managers, Messrs Anthony Aurentz, C. H. Killinger, Chas. H. Meily, J. W. Mish, Geo. H. Reinohel, Grant Wiedman and Col. T. T. Worth. The regular semi-annual dividend of 4 per cent. was declared, but the Managers failed to order a reduction in the gas rate, which it was presumed had been fully provided for. The average rate obtained for gas in Lebanon is \$2.35 per 1,000 cubic feet, but it is quite likely, however, that a considerable concession will be made in the year. Large plant extensions were completed last year, these including a holder of 30,000 cubic feet capacity, the iron work for which was furnished by Messrs. Deily & Fowler, and the excavation and tank work by Mr. W. C. Whyte, of New York. Both contractors finished their tasks in their usual manner. An interesting thing in connection with the executive management of this Company is afforded in the case of Secretary and Treasurer Mish, who has acted in that capacity since 1856, the year in which the Company was incorporated. Of the 15 persons named in the original papers of incorporation but five are living, and only two of these are at present holders of the stock.

THE Poughkeepsie (N. Y.) Gas Company will this spring put up an auxiliary holder on the site of the Laurel street plant. As an evidence that cheap gas for cooking, heating and power purposes pays (the Poughkeepsie rate for these purposes is \$1 per 1,000) we may note that the Company now has in position 200 cooking and heating stoves, and the average monthly consumption chargeable to this use is rather over than under 250,000 cubic feet.

It seems that the Brush Electric Light Company, of Cincinnati, O., is in the position of the youth who filled his mouth without paying due heed to the capacity of the same. In its eagerness to secure the contract for the public lighting it bid the remarkable rate of \$59.98 per lamp per annum, the schedule calling for all-night lighting and 2,000-candle power. We think the Company is hesitating in the breach, simply because at the figures noted it must lose money on every lamp that it would maintain. It is said that the "Parent Company," which it is presumed in this case is the Thomson-Houston Company, of Boston, objects to completing the contract for the simple reason that there "is no money in it." In any event, the Company is not taking any steps to get ready for the work.

At the annual meeting of the Fresno (Cal.) Gas and Electric Light Company, the following result was reached: President, Lewis Leach; Vice-President, F. G. Berry; Secretary, F. C. White; Superintendent, Daryille Decker; Assistant Superintendent, S. E. Johnson; Directors, Lewis Leach, F. G. Berry, P. P. Dryler, W. W. Phillips and C. M. Berry. Important betterments will be made at Fresno this season.

WE understand that the formation of a Gas Company for Aurora, Neb., is being seriously considered. Aurora is the capital seat of Hamilton county, and is growing rapidly in population and wealth.

THE recent rise in Baltimore Consolidated gas shares is attributed by some to the likelihood that the City Council will pass an ordinance based on the lines of the proposition recently submitted by Mr. Armstrong, whose argument and suggestions will be found in the JOURNAL for December 23, 1889. Perhaps this likelihood may have had some effect in the direction indicated; but the "guessers" should not lose sight of two other factors that would cause a similar result—the greatly increased business of the Company, which now more than ever feels the impulse of good management in all its departments.

THE Supreme Court of the State of Illinois has decided that an accepted franchise constitutes a contract. This finding was made in the case of the Chicago Municipal Gas Light and Fuel Company vs. the Town of Lake, and the salient points of decision are: The revised statutes of Illinois, c. 32, section 5, which authorizes corporations to exercise all powers necessary to carry into effect the objects for which they are formed, does not empower a gas company, incorporated for the purpose of supplying gas to towns, to lay pipes in the streets of a town whose charter gives the town authorities power to control and regulate its streets, without the consent of the town. A town ordinance authorizing a gas company, on condition of its furnishing gas at specified rates, to lay pipes in the streets, is, after it has been accepted by the gas company, a contract and not a revocable license.

WE understand that Mr. Frederic Egner has been appointed Engineer-in-Chief of the Laclede Gas Company, which means that he is to have charge of the works' end of the gas supply of the city of St. Louis. A superintendent is to be named for each station division of the plant. While not in position to say that the appointment has been officially made, nevertheless our information comes from a source so unlikely to be misinformed that we will venture to extend to him our congratulations on his promotion.

Experiments on the Relation of Electric Lamps to Combustible Bodies.

The Paris Society of Electricians have carried out a series of experiments as to the danger of fire from electric lighting. An experiment was made with a bare wire, placed on a small board, and in part with a second board—a wire which should normally conduct a current of about four amperes—and the current was carried up to 40 amperes without the wood commencing to carbonize. For a current much more intense the wood took fire at the part where the wire is uncovered before burning the other part, where the want of air made inflammation slower. It is known that these accidents are avoided in a very efficacious manner in practice by the use of fusible plugs. In order to determine to what extent the lamps themselves were capable of setting fire to strips and combustible bodies placed in their vicinity, the globe of an ordinary arc lamp of the Canse system was enveloped in several thicknesses of green tarlatan; a 32 candle incandescent lamp was enveloped in the same way, the folds of the material being joined under the lamp by an india rubber band; a lamp of 33 candles was covered with a cotton cap of double thickness; another was covered with a calotte of black silk, which was in its turn covered with another of black velvet; two lamps were covered with two layers of gummed wadding, white in one case and black in the other; a lamp of 32 candles was placed in vertical fold formed by an old theatrical decoration; and lastly, a lamp of 300 candles was applied against an old decoration. It was found that neither carbonization nor exaggerated heating took place in 20 minutes in the first, second, fifth or seventh experiment; at the end of a minute and a half the material in the eighth case carbonized at contact with the glass and began to burn without flame; at the end of two minutes, after melting and carbonization of the layers of wadding, the lamps in experiment sixth burst in, setting fire to the envelope; in about six minutes the velvet calotte was carbonized and began to burn slowly; at the end of ten minutes the cotton cap was partly carbonized at the points of contact, but combustion had not been commenced.

The Market for Gas Securities.

THE market for city gas shares was buoyant during the week, and the investment demand was a feature of the purchasing. No doubt the December and January interest and dividends are finding their way into permanent investments. Consolidated sold to-day (Friday, noon) at 95½, and it is worthy of note that this is the highest figure touched since 1887. Other city shares also joined in the upward movement. All classes of Brooklyn stocks are strong and higher. Chicago Trusts are steady at 44¼ to 44¾; and Baltimore Consolidated is up to 49¾ to 50. The Poughkeepsie (N. Y.) Company has increased its capital stock from \$84,000 to \$100,000. The shares of this Company are freely bid for at 120, with no offerings.

The Chemistry of Illuminating Gas.

Article XXXV., in the well written series on this subject, as contributed by Mr. Norton H. Humplrys to the *London Journal*, is as follows:

An important paper on the manufacture of illuminating gas from paraffine oil was read before the Royal Scottish Society of Arts, by Dr. Stevenson Macadam, in 1882. He stated that for several years past his attention had been repeatedly drawn to the subject of the production of gas of a permanent quality from these oils. At the commencement, the experiments were not very satisfactory, owing to the varying quality of the oil; but later on, by working with special kinds of oil which had to some extent undergone purification, and by paying attention to the question of the temperatures at which these oils were subjected to destructive distillation, he obtained reliable results. He had employed the crude oil which first came over in the distillation of shale for the purpose of making permanent gas, and had also taken it as a sort of standard as to the quality of the gas obtained from the other oils. If the crude oil was distilled and the volatile spirit removed from the distillate, green oil was obtained; and this, when rectified by the employment of acids and alkalis, so as to remove the tar bases, and treated for burning oil, intermediate oil, and solid paraffine, yielded a residue known as blue oil. An extremely volatile spirit known as gasoline was extracted from the first distillate of crude oil; but it was so combustible and explosive as to be unsuitable for the preparation of gas. An oil suitable for gas making should be thin enough to run readily into the retort at ordinary temperatures; and regard should be had to the specific gravity, and to the flashing and firing points. As to the method of working, he kept the retort at a cherry red heat, for which purpose some little skill was necessary, just as with a coal gas retort. The oil was supplied to the retort from a suitable reservoir through a long syphon tube, so as to prevent the gas being driven back, and the supply of oil could be easily regulated. Working in this manner no difficulty arose. The retorts kept wonderfully clean, and after working one for a whole day there would only be a little deposit of soot. He obtained the following practical results:

	Crude oil.	Green oil.	Blue oil.
Cubic feet of gas per gallon,	98.7	102.5	127.4
“ “ “ ton.	26,026	25,977	32,492
Candle power of 5 cu. ft.	50.4	53.2	54.3

About 80 per cent. of the quantity of light that would be obtained by burning the oil in lamps of the best construction was represented by these quantities of gas; and the cost of a ton of crude oil was £4 18s. 10d., or something less than 4s. per 1,000 cubic feet of 50-candle gas. The crude oil has the disadvantage of a low flashing point—92° Fahr. The green oil, having had the more volatile constituents extracted, was better. It flashed at 165° Fahr., and fired at 193° Fahr. It could be obtained for 7d. per gallon, or £7 9s. per ton. The blue oil was heavy, but fluid at ordinary temperatures, and, of course, more expensive. Dr. Macadam had also worked with a number of other oils, but had not obtained satisfactory results either in regard to quality or quantity. The heavier oils obtained by the destructive distillation of coal were included in this category. The best result obtained from them was 95 cubic feet of 42 candle gas per gallon, or 25,000 cubic feet per ton. The manufacture of oil gas was much simpler than that of coal gas. No scrubbers or purifiers were needed. The gas was simply passed through the condensers, where a little tar separated, and then it was conveyed to the gas-holders, and was quite permanent.

In a communication to the *Journal*, a year or two later, Mr. Ivison Macadam mentions the important fact that gas made from “crude oil as obtained from shale, or semi-refined varieties, such as the so-called “blue or green oil,” is much contaminated with sulphur and ammonia compounds, and with carbonic anhydride. It may here be remarked that there is considerable divergence on this point. As just noticed, Dr. Stevenson Macadam infers that the oil gas needs no purification. As a matter of fact it is usual to subject oil gas, in practice, to the action of a scrubber and a lime purifier, even when secondary products are used; so we may safely infer that this would be indispensable in the case of crude oil or crude petroleum. If the gas is to be used for buoys, railway trains, etc., the impurities may remain; but he considers it necessary that they should be removed if the gas is to be distributed in the ordinary way. He therefore suggests the employment of purer oils as a means of avoiding the expense of purification. He then describes the apparatus patented by Mr. Paterson, which simply consists of a number of tubes carried through the lid of an ordinary horizontal retort, nearly to the back end. The fluid is fed into these tubes and is vaporized as it passes along them. The vapor in the course of its return journey from the back to the front of the retort, is converted into permanent gas. The conversion is not complete, as a quantity of oil is deposited in the con-

densers, and it is so far charged with soot that it cannot be used again. But the results are very satisfactory; 100 cubic feet of 60-candle gas being readily obtained from ordinary burning oil. In this gas there are about 36 per cent. of olefines condensable by bromine; and the carbonic anhydride does not exceed 1.4 per cent. The proportion of this impurity would, however, depend upon the quality of the oil used. Reckoning the oil at 6d. per gallon, and the manufacturing charges at 1s., the cost of 1,000 cubic feet of oil gas would be 6s. But in comparing this with ordinary coal gas the quality must be considered. Bulk for bulk, the oil gas would be dearer; but when the 60 candle oil gas is compared with 16 or 20-candle coal gas it is much cheaper, light for light.

At a later period this gentleman read a paper before the Glasgow and Scottish Section of the Society of Chemical Industry, comprising a description of practical tests conducted upon several kinds of oil obtained in the Scottish shale industry, and one test of ordinary American petroleum. The results obtained are considerably higher than those already indicated, which may be due to improved apparatus, and also to the use of a burner suited to the consumption of these high quality gases at the photometer. In the course of the discussion which followed the reading of the paper, Dr. Wallace asked if the author had tried ordinary crude oil from blast furnace tar. A trial of this substance made by himself did not afford very promising results. It gave a large proportion of tar in the condenser, about one-third of the whole, and exhibited a tendency to choke up the pipes and to deposit carbon in the retorts. This oil was very cheap, and if it could be conveniently applied, it might well be used in conjunction with common coal as a means of producing gas equal to cannel gas—say, 22 to 26-candle power.

This subject was daily increasing in importance, because the cannel coal fields, particularly those of the better class, were being rapidly worked out, and some gas suppliers had even thought of reducing the quality of their gas, in view of the difficulties that might be experienced in the obtaining of supplies of first-class or even second-class coal. Mr. W. Foulis criticised the Paterson apparatus. He thought the small tubes would be likely to get choked, and that, being fixtures, they would interfere with the removal from the retort of the carbon that would undoubtedly accumulate. He also suggested the use of a jet of steam in conjunction with the oil. A simple apparatus on this principle was used in America in ordinary retorts, and, being attached to the lids, it could be taken away or brought into use, as might be desired, in a few minutes. It consisted of a tube attached to the mouthpiece and extending nearly to the back of the retort. Inside it was an inner tube, into which the oil was blown by a jet of steam. Escaping from this, the vapor and steam passed down the outer tube to the back of the retort, and were converted into permanent gas in coming forward to the ascension pipe. Professor Mills asked how long the retort would run without cleaning, and also as to the quantity of fuel required to maintain the high temperature at which it was worked. Mr. Macadam said he had not obtained satisfactory results, or figures of any practical value, with blast furnace tar; and he did not think the Paterson apparatus would give good results with such oils. The rectified coal oil used in his experiments was obtained from ordinary coke ovens. Though the tubes in the retort might at first sight appear an objection to a practical man, he had worked with them for some months without choking; and the apparatus had been in the hands of ordinary workmen, in no way specially skilled. The tubes were attached to the door of the retort, and could be removed with it; so they could scarcely be regarded as fixtures. It was seldom that cleaning was required, but when necessary it could very easily be done. He had made some experiments with the use of a jet of steam, and would bring forward his results on some future occasion. The gas had been rigorously experimented upon in regard to permanency, and proved to be quite as permanent as the coal gas supplied in Edinburgh. Although the tar contained a large proportion of naphthaline, it must be remembered that the proportion of tar was small; and he could not say if there was much naphthaline in the gas. He could not at the moment give the cost of the gas.

The preceding, together with some other matter relative to the subject of gas making from oil, invoked an editorial article in the *Journal* presenting other phases of the matter which should not be passed unnoticed. While admitting that experiments of this kind are deserving of every encouragement, as it is impossible to learn too much about the gas-making properties of mineral oils, especially as throwing a side light on some of the obscurities of coal gas manufacture and purification, it was submitted that there is a wide chasm to be bridged before the system of oil gas making can be worked in practice on a large scale. Professor Macadam's results were obtained from iron retorts worked at moderate heats; and there seemed to be a general idea that these liquid hydrocarbons needed only a moderate heat to gasify them, and

further, that this heat should be applied by degrees, so as first to convert the oil into vapor, and then to "fix" the vapor as a permanent gas. The experience of gas engineers who had had occasion to carbonize oil in ordinary gas works did not agree with this, as they found that the hottest clay retorts were best for the purpose. The residual deposit of carbon was the *crux* of oil gas making. Professor Macadam admitted that at least three-eighths of the burning oil remained in forms other than gas; and it might be assumed that carbon accounted for a considerable portion of the loss. The carbon deposit troubled the early American carbonizers of oil, and finally convinced them that they were working on the wrong principle. As soon as the oil met the heated surface, the more volatile portion passed off as vapor. The "fixing" of this vapor was attended with some formation of carbon, which was deposited in the retort. The liquid that remained was found to be heavier, richer in carbon, more difficult to gasify, and left a considerable deposit of carbon. So the result was a rapid accumulation of carbon, especially where the liquid entered the retort, but also upon all parts of the heated surface. In the iron retort comparatively little deposit would be formed at first, but as it deposited it would form a coating on the interior surface of the retort, like boiler scale, which would reduce the temperature to which the fluid was exposed. After a time the foul retort would not give more than half as much gas as was obtained at the commencement.

Many attempts had been made to get over this deposit of carbon—such as filling the retort with thin sheet or scrap iron; but the fact remains as one of the gravest evidences against mineral oil gas, that the direct carbonization of oil from gas has been abandoned in the United States after repeated trials. These attempts had discovered that the two principles that the oil must be gasified at the highest possible temperature, and that contact of the fluid with the interior surface of the retort should be avoided as far as possible. This might be accomplished by injecting the charge in a spray sufficiently fine to be gasified by radiant heat before it could touch the sides.

Carburetor for Gas Engines.

U. S. Letters Patent (No. 415,978) were granted on Nov. 26, 1889, to D. S. Reagan, of San Francisco, Cal., for an improved carburetor for gas engines. In describing the same Mr. Regan explains that the details of construction will be readily understood by an examination of the drawings, in which Fig. 1 is a vertical section taken through *aa* of Fig. 3; Fig. 2 is a perspective view of the exterior of the carburetor; Fig. 3 is a horizontal section taken through *dd* of Fig. 1; and Fig. 4 is a view showing the connection of the carburetor with the engine.

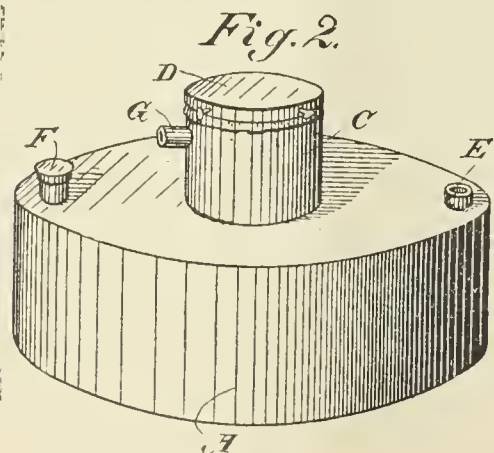
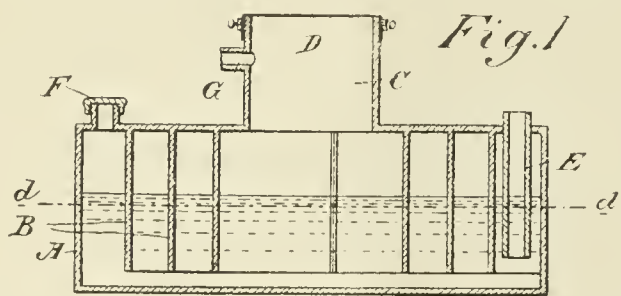

The object of the invention is to provide a device for charging atmospheric air with the vapor of a light hydrocarbon liquid, and transmitting this vapor directly to the engine cylinder, within which it is ignited and exploded, so as to propel the piston of the cylinder, said piston acting as a pump during alternate strokes, by which a sufficient quantity of air is drawn into the vacuum produced by the movement of the en-

gine piston to form a single charge for the engine, the carburetor ceasing to act immediately upon the stopping of the engine.

A is the exterior casing of the carburetor, having an extension or chamber *C* in the center of its upper portion. The top of this chamber *C* is covered by a flexible diaphragm *D*, which may be made of any suitable flexible material—as leather or parchment—and which serves by its flexibility to relieve the apparatus from the sudden vacuum which would otherwise be caused by the stroke of the engine piston.

G is a pipe extending from the chamber *C* to the engine cylinder *H*, and through which the carbureted air passes to the engine, being drawn

Fig. 3.

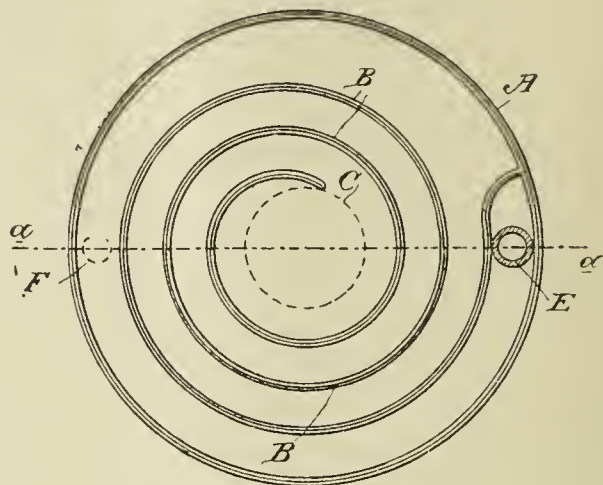
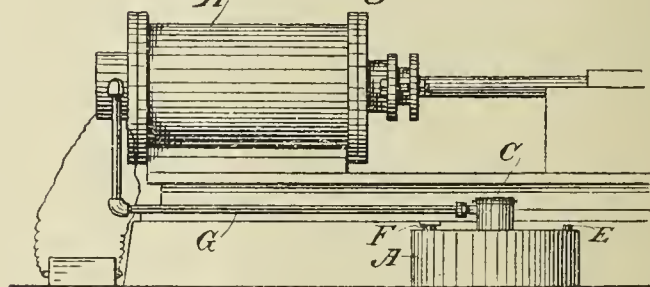

Fig. 4.



in at *E* by the vacuum caused by the forward movement of the piston when the valve is open.

The carburetor proper consists of a vertically arranged spiral partition *B B*, extending from the top of the casing *A* down to a point near the bottom, leaving a small space beneath the lower edges of the convolutions of the spiral, through which the liquid contained in the carburetor may pass freely and be constantly maintained at an even saturation throughout the apparatus. The liquid is introduced into the chamber through a filling nozzle, as shown at *F*, and is maintained at a sufficient depth to fill from one-half to two-thirds of the chamber.

E is a pipe extending into the top of the chamber *A*, and having its lower end very near the bottom of the chamber and beneath the surface of the liquid. This pipe is placed at the outer end of the spiral, and when the engine is in motion air will be drawn into the carburetor through this pipe by the stroke of the engine piston. This air being delivered beneath the surface of the liquid causes a considerable agitation, and by its ebullition through the liquid it becomes charged with the vapor, while its passage over the surface of the agitated liquid, following the channels made by the spiral, will complete its saturation, so that when it has reached the center, where it is delivered upward into the chamber or extension *C*, it is sufficiently saturated for the purposes of the engine. At each stroke of the piston, when the valve is open to allow the cylinder to receive a charge, vapor is drawn into the cylinder from the chamber *C*, and a corresponding amount of air is drawn through the pipe *E* into the carburetor, the chamber *C* being thus supplied with successive charges during the operation of the engine only. It will be seen that by this construction the air is drawn through the apparatus by means of the vacuum produced by the engine piston, and that there is no chance for leakage by forcing the vapor out through any openings in the carburetor. The pipe *E* acts as a seal to prevent any return of the air which has been drawn into the apparatus, and the flexible diaphragm *D* acts as a relief, vibrating easily with each stroke of the piston. The amount of air drawn into the carburetor at one stroke passes into the engine cylinder at the next stroke, and it will be manifest that only so much air is carbureted at each time as will serve for the following stroke of the engine piston, the operation ceasing instantly when the engine stops.

The Foulis Regenerative Furnace.

U. S. Letters Patent (No. 418,314) were granted, on December 31, 1889, to Mr. William Foulis, Glasgow, Scotland, for improvements in "regenerative gas retort furnaces," the protection sought for being supplementary to that obtained by the inventor in England on June 19, 1886, the serial number of the English patents being 8,157. Although the Foulis system has been described in the JOURNAL, we are inclined to the view that the publication of the inventor's specifications in respect to the American patent will not be without interest. Mr. Foulis says :

In regenerative gas retort furnaces, as at present arranged, combustible gas produced by partial combustion of fuel in a gas producer enters the combustion chamber, where it meets and burns with air heated by its

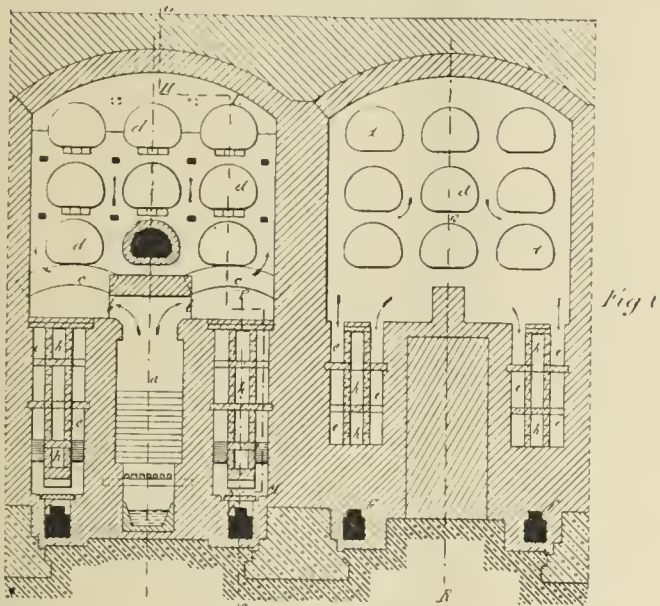

passage through flues arranged side by side with those which carry off the waste products of combustion.

Usually the gas enters the combustion chamber in a horizontal direction and the hot air rises vertically to meet it, so that the main heat of the combustion is directed immediately upon the structure above, causing rapid deterioration of the structure, and producing deposits and incrustations which seriously interfere with the free passage of the gases and render necessary frequent stoppage and repairs.

The object of the present invention is to remedy this evil in such furnaces, which is effected in the following manner: The hot air flues, instead of opening vertically into the combustion chamber, are continued beyond the point where the gas enters it. They are then directed upward to about the level of the combustion chamber and open with widened mouths into the flame chamber, where the air meets the gas and enters into combustion with it. The gas and hot air being thus made to meet

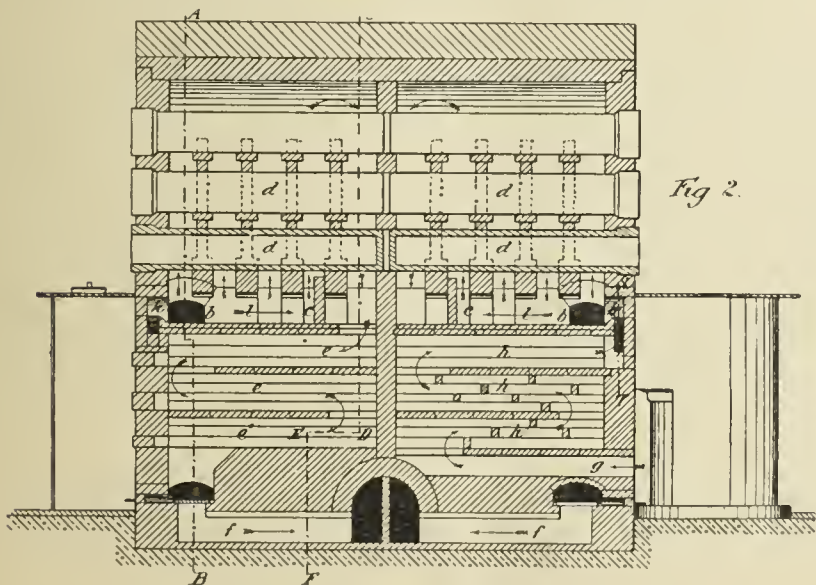

on the same level as they are moving horizontally, the flame, instead of being directed upward, impinging on the structure above, and causing intense local heat, sweeps freely along the flame chamber, delivering its heat uniformly over the furnace without such local intensity as can damage the structure. It is found, moreover, that by thus permitting the flame to take a free course, impinging as little as possible on any solid obstacle, more perfect combustion and complete evolution of heat are secured.

The accompanying drawings are vertical sections showing this invention applied to a regenerative gas retort furnace, these sections being taken on different planes, as follows :

Fig. 1, in its left half, is a section on *AB*, and in its right half on *CD EF*, of Fig. 2, which on its left half is a section on *GHIKLMNO*, and on its right *GHIKPO*, of Fig. 1. Fig. 3 is a section on *QR*, of Fig. 1, and Fig. 4 is a section on *ST*, of Fig. 2.

The gas generated in the producer *a* passes by the flues *b* into the combustion chamber *c*, where it meets with the supply of heated air and burns. As indicated by the arrows, the flame, which is mainly developed in the chamber *c*, and the products of combustion circulate between and around the retorts *d*, and then the products descend along the zigzag channels *e* to the flues *f*, whence they pass to the chimney shaft. The air entering at *g* ascends the zigzag channels *h*, which are arranged between the channels *e*, and separated from them by thin partitions, so that the air in its ascent along the channels *h* becomes heated. The uppermost channel *h* is extended beyond the mouth of the gas flue *b*, and an uptake from its end expands, as shown in Fig. 4, to a wide mouth *k*,

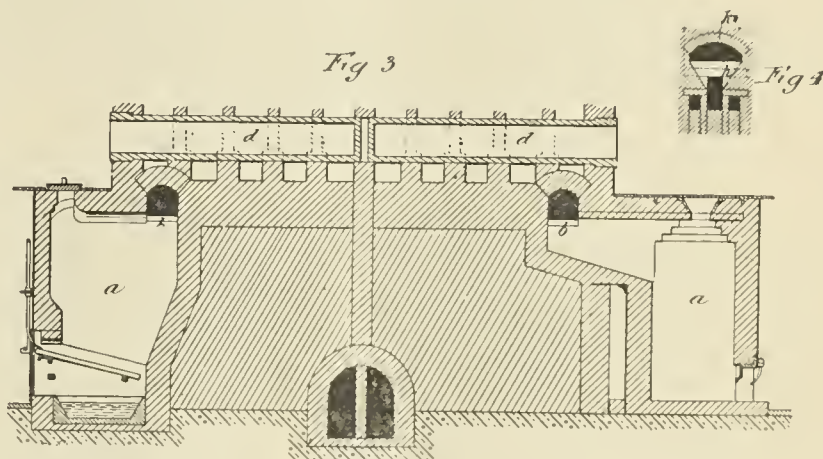

opening into the combustion chamber *c* at or about the same level with the gas flue *b*. Thus the heated air directed across the stream of gas mingles with it, supporting combustion and producing a gentle flow of flame along the chamber *c* (indicated by the arrows *l*), the flame and products thence diffusing themselves among the retorts.

Instead of a single mouth to the gas flue *b* and the air supply *k*, there must obviously be several mouths, so as to subdivide the gas and air into several streams directed either obliquely across or parallel to one another, so as to produce a flame traveling horizontally along the combustion chamber *c*.

I claim :

In a regenerating gas furnace, a combustion chamber, the walls thereof provided with horizontal air passages and horizontal gas passages opening into the said chamber in the same horizontal plane, near the bottom thereof, whereby the resultant flame is caused to travel horizontally near the bottom of the chamber before rising, as and for the purpose described.

The Deterioration of Electrical Conductors.

M. Firmin Larroque has published an account of some of his observations on the deterioration of copper conductors by the long-continued passage of strong currents of electricity through them. His attention seems to have been first called to the question in 1884, when he examined the electrical and mechanical properties of some pieces of electric lighting cables that had been in use for some years. One specimen—a portion of a cable which had conveyed electricity to a lighthouse lantern for a period of twenty years, gave very striking results. It was extremely brittle, and broke in fragments under the hammer, whilst its fractured surface resembled in all particulars that of electrolytic copper. The current through this cable had not been in any way excessive, nor had it been subjected to any heavy mechanical straining. Similar though less marked results were obtained with other cables, which had been in use for shorter spaces of time. The currents in all these cases were direct, but a portion of the secondary circuit of a small Runkorff coil, for many years employed in igniting the gas of a Lenoir gas engine, gave M. Larroque an opportunity of examining the effects produced by an alternating current. This coil had become very brittle, and broke up during the process of unwinding; its electrical resistance, moreover, had increased about 31 per cent. during the years it had been in use. M. Larroque then determined to make some systematic experiments on this subject. He endeavored in the first place to determine whether the long-continued passage of a powerful current of electricity

caused any expansion of the wire, and secondly, whether, and in what degree, it altered the elastic properties of the material. For each experiment nine pieces of copper ribbon 10 mm. broad and .3 mm. thick, were provided, and for the second of the experiments, each specimen was bent into a zigzag of 80 bends. One end of the zigzag was attached to a rigid support, and from the other a weight of 10 grammes was hung. Some of the specimens were hard drawn copper, and the others were made from the annealed metal. Through seven of the nine specimens a current, in some cases alternating, in the others direct, and ranging in different cases from .5 to 2 amperes was passed, whilst the other two specimens, one of which was hard drawn and the other annealed, were kept as standards, so as to eliminate any changes arising from causes unconnected with the passage of an electric current. Should the elasticity of the specimens be altered by the current, the position of the 10-gramme weight would of course vary correspondingly, and means were taken for the accurate estimation of such changes. During the first nine months of the four years over which the experiments have been prolonged, the observations showed a want of uniformity, but since then have been very regular, and the results now published show that the elastic properties of the wires have been very considerably changed. This variation takes place the more rapidly with strong than with weak currents, and with alternating than with direct.

The Kusnezov Gas Washer.

Vassily Kusnezov, of St. Petersburg, Russia, has been granted protection in this country (Letters Patent No. 415,646, Nov. 19, 1889) for a gas washer for application to gases obtained from naphtha or crude petroleum. Referring to the drawings, Fig. 1 represents a vertical section on the line 1 2, Fig. 3; Fig. 2 is a perspective view with the top and two adjoining sides cut off; and Fig. 3 is a sectional plan view on the line 3 4, Fig. 1.

The washer consists of a metallic casing *A*, preferably of rectangular form. This casing is divided by a horizontal partition or plate *B* into two compartments or chambers, in communication with each other only by a vertical pipe or duct *C*. The lower chamber, into which the gas to be purified enters by the openings *D*, is divided by vertical partitions *E*

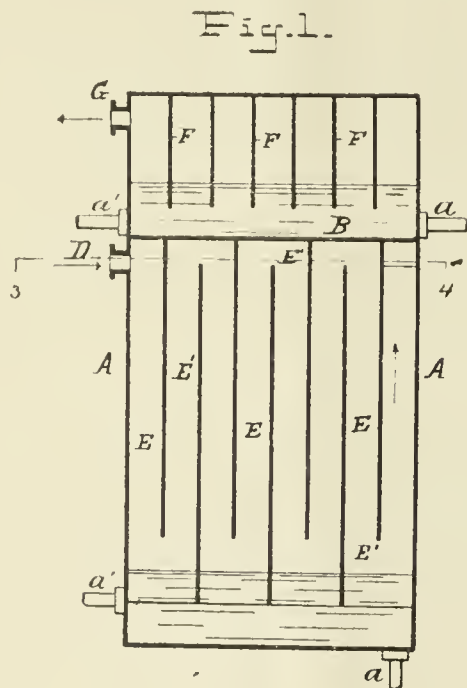

and *E'*, which cross each other at right angles and form a great number (from 64 to 500) of vertical chambers or ducts, communicating with each other alternately at the bottom of the casing above the level of the water contained therein, and at the top immediately under the partition *B*. By this arrangement the gas must pass in a circuitous course consecutively through all the vertical channels and ducts of the lower chamber, as shown by the arrows in Figs. 2 and 3, until it reaches the last vertical duct *C*, which leads to the upper compartment. The partitions *E'*, beginning at some distance from the plate *B*, do not reach the bottom of the casing (see Figs. 1 and 2), so that the water is at the same level in all the channels or ducts. In passing under the lower edges of the partitions which do not reach down into the water the gas is brought into contact with the water, which retains the particles of naphtha contained in the gas (and which escaped the hydraulic main), and is thereby cooled and purified. After passing through all the channels or ducts of the lower chamber the gas ascends through the tube or duct *C* into the

upper chamber, where it passes over a layer of water, with which this chamber is filled to about one third of its height. In this upper chamber there are arranged a number of metallic partitions *F* parallel to

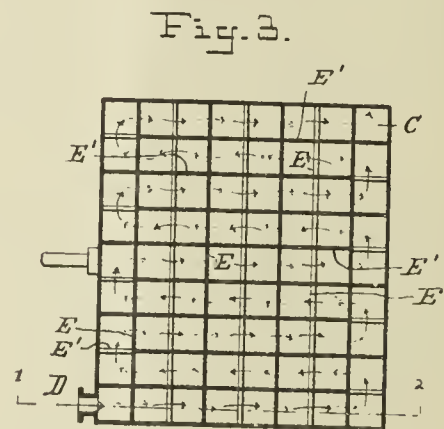
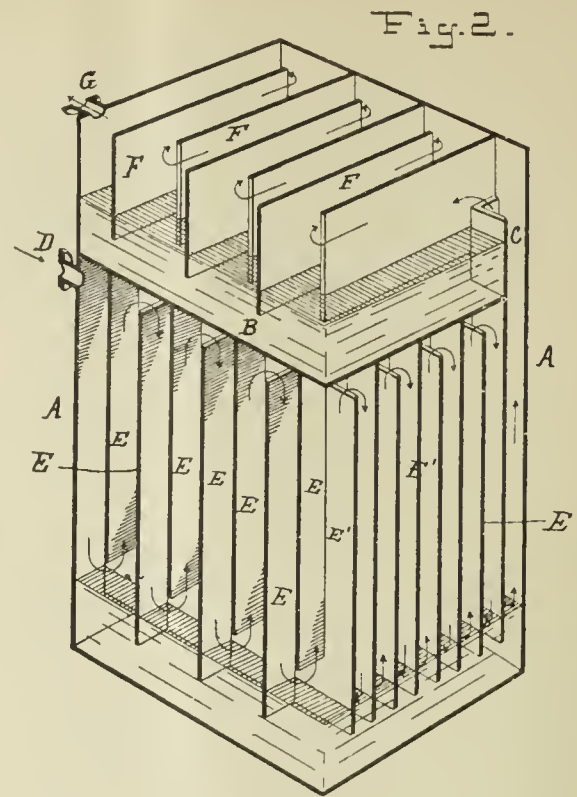

each other, and alternately open at opposite ends, so as to form a serpentine channel for the extended flow of the gas over the water, by which it is finally purified, and is let off from the apparatus by the opening *G*. An inlet *a* and outlet *a'* for the water are provided for each chamber.

The Incandescent Light Controversy.

The *Scientific American* believes that the controversy now in progress between the promoters of the rival systems of incandescent lighting, though some will think of doubtful expediency, so far as the companies are concerned, admirably serves to acquaint a public now grown timorous, with the detail of operation, and with the nature of precautions which, if employed, would render both systems entirely safe, at least to the user.

With perceptions sharpened by constant investigation, the rival champions have each in turn pointed out the defects of the other's system of lighting—defects which, because of the reticence of the companies, have till now only been surmised by the public.

It is the purpose of this article to examine these as they have been pointed out, inquiring as to the mischief that might come, and describing the steps which the studies of practical electricians show to be necessary for their correction.

The alternating current system, the attack on which led to the present controversy, is used very generally on both sides of the water for incandescent as well as for arc lighting; its chief recommendation being the power it possesses to light extensive districts from a single station. In an arc light circuit the current reaches the lamps directly from the conductors, the voltage varying, according to requirement, from 1,200 to 2,000. In the incandescent system this high voltage is maintained in the street circuit, but by the interposition of converters or transformers, located in or near each building, a secondary current of scarcely more than 50 volts is produced. This is suitable for operating a number of lamps, each equal to a full working five-foot gas burner of 16-candle power. The

transformer is made up of two separately wound and insulated coils, one of thin wire connected to the street mains, and the other of thick wire connected to the wires of the building to be lighted; currents sent through the coil of thin wire induce in the nearby coil of thick wire currents the voltage of which bears the same ratio to that of the primary current as the number of convolutions in the primary bears to the secondary coil of the converter. For example, if the electromotive force of the primary or street current is 500 volts, and the electromotive force of the secondary current is required to be 500 volts, the primary coil will require ten times as many convolutions as the secondary. The promoters of this system say that it is an easy matter to make the insulation between the two already separated coils effective and to prevent the current in the primary wire from penetrating it. On the other hand, their rivals say that no system of incandescence which has a high tension current behind it can be rendered absolutely safe, that breaks or leakages will come, because the mechanisms of man, however ingenious, are never perfect, and human watchfulness and foresight not to be depended upon. They instance the case of the employee of the Manhattan Electric Light Company, who got his death shock while carrying a portable incandescent light in the engine room of the station, a lamp, be it said, supposed to be protected from the main current by a converter. There would seem to have been a break in the insulation of the wire, which his hand must have rubbed against, his face perhaps touching a steam pipe, thus forming a ground. The station men say that only 120 volts were on the circuit, but as this would not destroy life, it is evident that the high pressure alternating current must have reached the wire, and passing through his body, got to the ground through the steam pipe.

This, however, happened within a station, and it is claimed cannot be construed as an argument against the safety of the system any more than the death of a man who should fall against a fly-wheel could be used against steam engines. The alternating current people say, and truthfully, it would seem, that the record does not furnish proof of a single case of death among the thousands who have been using the system where applied to incandescent lamps.

The continuous low tension system is that used in the circuits of Mr. Edison. Here the voltage on the street circuit, varying between 100 and 200, even the higher pressure not in the least dangerous to life, is the same on the house circuit. All underground mains are meshed into one network, and while in the alternating system the wires are designed to supply only about 1,500 to 2,000 lights per pair, and made of such a size that there is scarcely any decrease in the intensity of the lights at the further end, even when the demand for current is excessive, the low tension system at times calls for an enormous electrical energy, the pressure being far greater nearest the station than away from it. At times, when the switch is worked to put out the lights in a certain district an arc of blue flame is formed which must be blown out. This charge, made by a rival company, though true, is misleading, because the arc is harmless, never known to do any harm. The charge is made against the Edison system that it is subject to leakage which at times leads to fire. But it does not and cannot take life, while leakage from the alternating street mains can take life as well as start fires.

As will be seen, both systems have striking advantages, and to all appearance are fairly safe. Disinterested electricians, however, insist that to be rendered incapable of harm, where high tension currents are permitted in the streets, whether overhead or underground, every wire entering a house should be provided with a cut-out of lead or its alloy. It is a simple and inexpensive precaution by which a wire, however dangerously environed it may be, cannot transmit a high tension current beyond a certain point. Copper fuses at about 2,000° F., but lead at 608°, and its alloy at about 375°, and thus a strip of lead joining the house system with the outside current would melt and break off all connection should a vagrant current of high intensity essay to pass.

Coke and Charcoal Compared.

The *American Manufacturer* calls attention to the results of the following experiments, published by Dr. W. Thoerner, in *Stahl und Eisen*, in the matter of the comparison of coke with charcoal. He finds:

1. That charcoal consists of a large number of more or less regularly arranged cells which are joined together longitudinally. The walls of the cells are readily porous to gases, and are very easily oxidizable.

Coke, on the other hand, contains generally separate unconnected cells or groups of cells, the walls of which are composed of a dense and vitreous mass which does not admit of the passage of gas through it, and is exceedingly difficult to oxidize.

2. That the relatively smaller action in blast furnace practice of coke as compared with charcoal would be increased were it possible to cause

the structure and character of coke generally to more closely resemble that of charcoal, either by the formation of a coke more porous though sufficiently strong, or with greater certainty by rendering the coke substance more easily oxidizable.

The following table gives the results of the examination of several specimens:

Variety of Fuel.	Ash per cent.	Specific Gravity.		In 100 Grammes Coke.		Volume of 100 Grams of Coke.
		Apparent.	Real.	Cell Space Cubic Centimeters.	Coke Substance, Cu. Centimeters.	
1. Retort coke, Osnabruck Gas Works.....	3.8	1.825	0.850	61.6	54.8	116.4
2. Retort coke, Osnabruck Gas Works.....	7.5	1.811	0.868	60.6	52.2	115.2
3. Compressed coke, Cologne-Musen Co.....	7.7	1.852	0.974	48.6	54.0	108.6
4. Compressed coke, Cologne-Musen Co.....	6.9	1.786	0.909	40.2	56.0	103.2
5. Ordinary Coppee coke, Cologne-Musen Co.....	7.99	1.880	0.926	54.8	53.2	108.0
6. Carlsgluck and Planetfeld, Dortmund coal field....	7.8	1.825	0.909	55.2	54.8	110.0
7. Maassen, low level.....	7.3	1.852	0.890	54.4	54.8	112.4
8. Westhausen, Bodelschwingh.....	10.6	1.852	0.909	54.8	54.0	108.8
9. Neu-Iserlohn, Langendreer	8.8	1.852	0.874	60.4	54.0	114.4
10. Dannenbaum, Bochum....	8.45	1.894	0.800	59.6	52.8	112.4
11. Germania Works, Grevenbruck.....	7.6	1.909	0.963	58.4	52.4	110.8
12. Heinrichshutte, Au, a. d. Seg.....	7.6	1.887	0.980	49.0	53.0	102.0
13. Meiler coke, Silesia.....	2.9	1.488	1.646	28.4	67.2	95.6
14. Fine charcoal.....	2.9	1.626	0.382	200.4	61.6	262.0
15. Oak charcoal.....	2.45	1.347	0.587	96.2	74.2	170.4
16. Beech charcoal.....	2.10	1.481	0.594	100.8	67.6	168.4
17. Birch charcoal.....	1.65	1.351	0.484	132.5	74.0	200.5
18. Anthracite.....	9.3	1.666	1.572	3.6	60.0	63.6
19. Bituminous coal.....	8.30	1.323	1.300	1.4	75.6	77.0

In comparing these results, Dr. Thoerner observes that amongst the coke samples examined the meiler coke has the least porosity—28.4 cubic centimeters per 100 grammes—and the ordinary retort coke the greatest—61.6 cubic centimeters. The porosity of coke produced in ordinary ovens varied from 54.8 to 59.6 c.c. per 100 grams., a notable exception, however, being the “pressed coke,” Nos. 3 and 4, produced on the Lurmann system, in which the porosity is only about 47 c.c. on the same weight of coke.

The porosity of the charcoal varied between 96.2 cubic centimeters and 200.4 cubic centimeters per 100 grams., and it is curious that pine charcoal, the most porous of the varieties examined, possessed the densest charcoal substance.

Microscopical examination of the form and size of the cells and the strength of the cell walls necessitated the use of thin sections, which were photographed under the microscope by Dr. Thoerner and engraved for his paper. It was observed that the smallest details of the structure of the original wood were preserved in charcoal, the arrangement of the cells being such that the gaseous products of coking could escape easily, and therefore in burning the charcoal oxygen could easily enter. The charcoal substance is not fused by coking, but remains in an easily combustible form, whilst the coke substance is found to be fused into a dense, impenetrable, vitreous mass.

Experiments on the resistance to crushing stress shown by the different varieties of coke were found to give erroneous results when the coke was carefully turned into a cylindrical form. Mr. John Fulton, of Johnstown, in his investigations on the physical properties of coke, relied greatly on the indications of hardness given by resistance to crushing stress, but Dr. Thoerner remarks that the use of cubes, as employed by Mr. Fulton in his experiments, is open to the objection that it is almost impossible to obtain from such a brittle material cubes of exactly the same size, and that he found that cubes produced were never free from slight cracks. It was, however, shown by the experiments with cylindrical test pieces that, as a general rule, the crushing strain of coke was from 0.97 to 1.73 kilograms. per square millimeter of surface, but as the results agreed very badly, a further series of tests was made in which the coke was cut to pieces of about 10 millimeters diameter, surrounded by an iron jacket and put under a piston, by means of which it was subjected to a crushing stress. The volume to which the coke was compressed by successive increasing loads was noted after each load, and

the results showed that the relative strength or compressibility was, as a rule, directly dependent on the porosity, both in the case of charcoal and in that of coke.

In the following, Sir I. Lowthian Bell's line of investigation into the relative resistance of coke and charcoal to carbonic acid, Dr. Thoenner subjected the specimens to a preliminary heating at a white heat in a current of hydrogen, and found a considerable loss in some cases.

The following numbers show the decrease in weight per cent.

No. 2.	Retort coke.....	0.25
No. 3.	Compressed coke.....	1.41
No. 4.	Compressed coke.....	1.15
No. 5.	Coppee coke.....	1.13
No. 6.	Carlsgluck, etc., coke.....	1.55
No. 7.	Maassen coke.....	1.70
No. 8.	Westhausen coke.....	1.70
No. 10.	Dannenbaum coke.....	0.75
No. 13.	Meiler coke.....	29.70
No. 14.	Pine charcoal.....	17.90
No. 15.	Oak charcoal.....	13.20
No. 16.	Beech charcoal.....	11.80
No. 17.	Birch charcoal.....	13.20

The above considerable loss in the case of Meiler coke and others is explained as being due to the escape of hydrocarbons and not to evolution of water.

In examining the action of carbonic acid and of air on the specimens, 1 gram of each sample of coke and 0.5 gram of each variety of charcoal were placed in a platinum tray, and heated in currents of air or carbonic acid for different periods with the following results :

Fuel	Heated in Carbonic Acid (Loss Per Cent.)			Heated in Air for 10 minutes. 4.5 liters air being used. Loss Per Cent
	For 15 Minutes. 500 c. c. CO ₂ used.	For 30 Minutes. 1 Liter CO ₂ used.	For 2½ Hours. 5 Liters CO ₂ used.	
1. Retort coke.....	10.6	27.2	46.8
2. Retort coke.....	11.8	36.6	45.0
3. Compressed coke...	13.8	38.0	52.0
4. Compressed coke...	8.4	27.2	48.9
5. Coppee coke.....	8.7	27.5	50.1
6. Carlsgluck coke....	8.3	20.3	54.4
7. Maassen coke.....	8.9	29.3	54.5
8. Westhausen coke..	9.5	26.2	52.9
9. Neu Iserlohn coke.	12.2	34.0	46.8
10. Dannenbaum coke.	6.8	22.6	57.1
11. Germanialutte coke	8.9	32.0	52.1
12. Heinrichslutte coke	6.9	24.3	52.5
13. Meiler coke.....	45.6	100.0	87.7
14. Pine charcoal.....	61.1	96.3	100.0
15. Oak charcoal.....	48.8	85.0	78.6
16. Beech charcoal....	60.4	95.0	80.3
17. Birch charcoal....	68.0	95.0	100.0
18. Anthracite.....	45.4
19. Bituminous coal....	74.4

Chimney Proportion.

A foreign contemporary calls attention to the fact that the rearing of high chimney shafts in connection with factories, chemical works, etc., constitutes a specialty in building construction, and may fairly be considered as a matter of very considerable economic importance.

We do not propose in the present paper to go at all practically into the details of high chimney construction. Readers desirous of information on this subject may be safely referred to Messrs. Robert M. Bancroft and Francis J. Bancroft's excellent book on the subject, which is an exhaustive and authoritative resume of the matter.

Our present purpose is to call attention to some articles which appeared not long since in a German technical contemporary on the matter, and which considered it with special reference to the question whether decrease in height of factory chimneys might not effect a saving of fuel without impairing general efficiency.

Herr P. Huth records a case in which the erection of a new boiler in a relatively disused building necessitated (after an unsuccessful attempt to use it) the demolition of the old chimney, the dimensions of which were: Height, 65.61 ft., lower diameter, 19.68 in., diameter of interior of chimney, 13.78 in. The entire length of the draught, including the flue, was about 98.42 feet. In the new chimney the entire length of the draught, including the flue, was proposed to be about 95.14 ft., and the diameter at the narrowest square portion, 25.59 in.

Partially for experimental purposes and partially with a view to economy, a trial was made of heating the boiler when the chimney was 39.37 ft. in height. Although the results were affected by the damp masonry, there was a distinct improvement perceptible as compared with the old

chimney. At a height of 45.93 ft. the trials were still more satisfactory, and at 52.49 ft. all requirements were completely fulfilled, the smoke being absolutely white and sometimes scarcely noticeable, without any soot or flying ash. The heating of the boiler was excellent, and the consumption of coal 15 to 20 per cent. less than was the case with the old chimney. The top was then finished in the usual way, without any further improvement or addition to the height.

From these facts Herr Huth deduces the fact that not only the height, but also the diameter of a chimney in proportion to its height, demand attention for economic and administrative reasons. High chimneys are, he considers, as a rule too narrow in proportion to their height, and hence do not draw well, or else waste fuel and cover the neighborhood with soot and flying ash. The effort to remedy these evils by still further increasing the height of chimneys leads to their aggravation.

Herr Huth suggests more detailed researches as likely to elucidate the subject further. In a later number of the same journal, Herr Ramdohr, of Gotha, confirms the assertion that there is a dearth of exact information as to this point. He alludes to the opposite extremes of making chimneys decrease or increase in their internal diameter at the top as compared with the base. He recommends uniform diameter, and thinks that this should be estimated rather fully, in order that the heated gases in the center of a chimney may be, if possible, surrounded by a cooler stratum which protects the brickwork to some extent from the heat.

This uniformity of diameter can be obtained by cutting the bricks or by dividing the chimney into sections and ascertaining that no portion of these had less than the minimum diameter. This diameter can be estimated in proportion to the extent of the grate surface of all the fireplaces which the chimney serves, being about equal to the flue grate surfaces. This varies with different combustibles, brown or mineral coal, wood, etc., from one-eighth to one-fourth of the entire grate surface. The lower a chimney the larger may be its cross section.

The height, even when the boilers are small, should not be less than about 50 ft. For large steam appliances a height of 100 ft. to 120 ft. will usually suffice, providing the cross section be suitable.

When the fireplaces are some distance from the chimney, the height of the latter would be about 160 ft. to 200 ft., the cross section being modified on account of the coating of the smoke gases during their passage.

As to the form of the cross section of such chimneys, it is considered that a circular shape is preferable on account of its resistance to the wind pressure. An octangular form is considered a very suitable alternative, as only one special shape of brick is indispensable; and finally, it is stated, that the top of the chimney should not be called upon to bear any but a very slight projection, the whole being carefully surmounted with iron round the top of the brickwork.

Petroleum Market for 1889.

Messrs. Watson & Gibson, in an article specially prepared for a New York city contemporary, thus review the course of the petroleum market for the year 1889 :

The year 1889 opened with a dull market in petroleum, at something of a decline from the latter days of 1888. The highest price during the first week of this year was 85½ cents. The total net stock on the 31st day of December amounted to 18,595,474 barrels. Early in the month of January a conference took place between the representatives of the Standard Oil interest and the organized producers, resulting in a harmonious agreement between them. By this agreement the Standard extended the time of a "call" of 3,500,000 barrels until July 1st, and the Standard agreed that it would at that date accept any of this reserve oil which might remain unsold at a net profit to the producer of at least five cents per barrel. The Standard were to continue to carry this oil until July 1st, or till any previous date, when it might be called by the producers. This agreement, being a continuation of an option previously existing, did not have any very important effect upon the price of oil. From the first of the year up to the present time there has been a continual and steady reduction of the stock of oil above ground, but this gradually improving change in the situation did not begin to assert itself until the present autumn, and then only in a very moderate and indifferent sort of a way. The prices during the early months of the year ranged between 85 and 92½, falling to 80 cents the latter part of April. On the 24th of June, being just prior to the expiration of the "call" held by the producers, there was an important change in the temper and extent of speculation in the oil market, and the total dealings on that day in the Consolidated Exchange ran up to 4,910,000 barrels. The price on that day advanced from 83¾ cents at the opening to 95, reacting before the close to 89¾. This was not only an important advance, but an utter surprise to speculators and traders. On the 28th of June the Standard purchased from the producers the 3,500,000 barrels of oil which they had been carrying, subject to a "call" by the producers. They paid for it 91½ cents. By this trade the producers made something over \$200,000, and the relations between themselves and the Standard, which began in November, 1887, at the time of the original shut down movement, were terminated.

The price during the early part of July held around in the vicinity of

90 to 92, but on July 20th it rose to 95½ cents, and on July 27th to 102¼, having on the latter day advanced from 95¼ cents. These higher prices naturally resulted in an increase of development work in the field, which gave a larger production during the autumn months than had previously been turned out. The total exports for refined oil for the fiscal year ending June 30th were 496,691,346 barrels, against 452,855,695 the year before. Early in the present autumn oil advanced above \$1.12 and there was a good deal of talk about very high prices for it, but speculation was almost at a standstill and the constantly decreasing stock of oil did not create any enthusiasm among buyers, or any adequate speculative response.

The growth of the Russian oil business and its successful introduction on an enlarged scale in the far East, and the completion of a pipe line across the Suram Pass, which lies between Baku and Batoum, are important features to be considered in estimating the value of American oil.

Secondly, the existence of a large field in Ohio, the visible supply of which equals the visible supply of Pennsylvania oil, selling at about one-sixth the price of the latter, exercised a bearish or at least deterrent influence on would-be buyers. It is not an established fact that Ohio oil can be economically refined, but it is stated to be a fact that its refining is chemically possible, and, as the production is now at the present low price, fully half the production in Pennsylvania, and its possibilities of increase are very great whenever its price shall be advanced, it remains a constant menace to the prices of Pennsylvania oil. The oil dealt in on the exchanges is Pennsylvania oil, and since the new oil coming out of the wells of Pennsylvania commands a premium of about 25 cents, none of the fresh oil goes into the tanks covered by the certificates dealt in on the exchanges.

The oil now in the custody of the pipe line companies, which is a good delivery on the exchanges, is the old Bradford and Alleghany oil, and it is deteriorating by age. We believe that Ohio oil will be utilized for the production of illuminating fluid and the Standard has for some time had a large refinery at Lima. It may be feasible to blend Ohio with the Pennsylvania oil. In view of all the conditions surrounding the business, the utter and complete absence of all speculative desire on the part of the public, and the interest which the Standard must have, as the chief consumer of petroleum for conversion into refined, we cannot see our way to recommend purchases of Pennsylvania oil at current prices, notwithstanding the apparently strong and bullish complexion of statistics. We think that the price of Pennsylvania and Ohio oil must be more closely approximated, and we predict that within the year 1890 the Standard will openly admit what they now deny, that Lima oil can be successfully and economically refined.

Fluctuation in Prices per Barrel (40 gals.) of Petroleum during 1889.

(Consolidated Stock and Petroleum Exchange.)

Months.	Opening.	Highest.	Lowest.	Closing.	Sales.
January.....	88½	88½	84	85½	18,369,000
February.....	85½	92¼	85½	91½	323,040,000
March.....	90½	93	88½	92½	14,031,000
April.....	90	91¾	81¾	84¾	17,472,000
May.....	84¾	86½	80½	82½	10,472,000
June.....	82¼	95	82¼	92¼	12,956,000
July.....	92½	102½	91	98½	11,888,000
August.....	98¾	100½	97	97¾	14,818,000
September.....	98	5,851,000
October.....	98¾	108¾	99¾	98½	13,222,000
November.....	107	112½	103½	103¼	13,664,000
December.....	103½	106½	102¾	103½	5,269,000
Year.....	88½	112½	80½	103½	420,152,000

(New York Stock Exchange.)

Months.	Opening.	Highest.	Lowest.	Closing.	Sales.
January.....	87½	88½	83½	86½	7,920,000
February.....	85½	92¼	85½	91¼	3,125,000
March.....	91¾	92½	88½	90½	8,876,000
April.....	90½	91¾	81¾	84¾	8,616,000
May.....	84½	86½	81	82½	7,884,000
June.....	82½	95	82	92¼	4,327,000
July.....	92¼	102	90¾	98½	8,251,000
August.....	99	100½	97½	98¼	4,023,000
September.....	98	101½	97½	99	2,444,000
October.....	98¾	108½	99	106	10,479,000
November.....	106½	112½	103¼	103¼	8,158,000
December.....	102½	105½	101¾	103½	2,984,000
Year.....	87½	112½	81½	103½	87,077,000

The net stocks of oil held by the National Transit Company at the end of each month in 1889 were as follows :

January.....	16,483,804 barrels.	July.....	12,004,533 barrels.
February.....	15,398,677 "	August... .	11,225,340 "
March.....	14,820,668 "	September.	10,482,268 "
April.....	14,152,787 "	October... .	9,761,353 "
May.....	13,380,306 "	November	9,230,266 "
June.....	12,694,145 "	December*	8,750,000 "

ITEMS OF INTEREST FROM VARIOUS LOCALITIES.

It is about settled that Cleveland (O.) will appoint an official gas inspector, and that his office shall be equipped with all the modern appliances for testing for purity and candle power. The next step will be to provide for the appointment of an electric light inspector, who shall also be required to report on the average lighting value of the arcs supplied to the city.

THE employees of the Laclede Gas Light Company were made happy on Christmas eve. by the reception each of a good-sized turkey. The donor was President McMillin.

JAMESTOWN, N. Y., intends to install and operate an arc lighting plant on municipal account.

THE competition for supremacy between the Fremont (Ohio) Gas Company and the local electric light company has terminated in the purchase of the former by the latter. The proprietors of the Gas Company are said to have received a good round sum for their property, which was valued at \$75,000. During the contest gas was sold at as low a figure as \$1 per 1,000, while electricity could almost be had for the asking.

THE following are the bids made in response to the second call by the authorities of Boston, for the public lighting by means of arc lamps, the Mayor having rejected the bids submitted under the first call on the ground that the rates were excessive: Suburban Light and Power Company, Roxbury district, 1-year contract, 39.99 cents per arc per night; 3 years, 38.99; 5 years, 37.99; for city proper, South Boston, West Roxbury and Dorchester, 5 years, 39.74 cents; Brookline Gas Company, for Brighton district, 5 years, 40 cents; Walworth Light and Power Company, for city proper, East and South Boston, Charlestown, Roxbury, West Roxbury, Brighton and Dorchester districts, 5 years, at 40 cents. The proposals were based on all and every night lighting, arcs to be of 2,000-candle power. The award of the contract was taken under advisement. It will be noted that the Boston Electric Light Company and the Charlestown Gas Company, both of which submitted bids in the first competition, did not make a tender in the last. The Mayor, however, received letters from each of the named corporations, both conveying the information that because of the restrictions in the specifications (the second set of the latter announced that no bid would be recognized that exceeded 40 cents per arc per night) they could not assume a contract at the maximum rate named and fulfil their obligations with justice to their stockholders.

AN independent authority, writing on the recent ill-advised labor agitation among the English gas stokers, says: "The gas strikes at Manchester and Salford are over. The places vacant by the ill-timed action of the leaders and the foolish complicity of the men have been to a large extent filled. Some of the old hands have returned—sadder, if not wiser, men, but many have left never to return. The rate payers of the city of Manchester and of the borough of Salford undertook to give more wages and to lessen the hours of labor. But they were not prepared to become the mere agents of the Gas Stokers Union, and to insist that none should be employed except union men. Hence they put up with some inconvenience rather than coerce the gas committees of the two corporations. No such demand has ever been made by the older unions, although strikes against non-union hands have sometimes taken place. Such strikes have usually been ineffective; they have entailed great suffering and misery, and at the best they have been won at great cost. If it is right for the men to strike against non-union hands, it is equally right for employers to insist upon employing none but non-union hands. The policy in either case is sure to give rise to a feeling of permanent hostility, and further it violates the spirit of the law which now gives to all men equally the right to combine. Recent experience shows that there is a disposition abroad to rely upon force rather than

*Estimated.

upon moral or legal right; but force only engenders force in labor conflicts."

IN the meantime we might remark that the difficulty between the proprietors of the Lockport (N. Y.) gas works and their employees has been satisfactorily arranged.

SOME time ago Judge Black, of the Missouri State Supreme Court, rendered a decision in respect to a case known as the "grading suit," under which it became necessary to construe certain sections of the charter of Kansas City. In his opinion Judge Black holds that the charter "is the supreme or organic law of the city, and supersedes all previous laws enacted by the general assembly of the State for the regulation of the city's affairs." Under this ruling it is now held by the municipal authorities of Kansas City that the city has the right to say at what rate gas and electric light shall be supplied. Section 12 of Article 14 of the Kansas City charter is: "Provided, That no such person or corporation shall in any event charge more for light for the city or private parties than the prices specified, from time to time, by ordinance of the city, and that the city shall also have power to regulate and fix from time to time the prices such person or company may charge for the renting of meters or apparatus for ascertaining the quantity of material or means consumed for lighting. And provided, further, That the city shall not, in making the original grant, nor in any manner subsequent thereto, ever agree or bind itself to pay any fixed price for lighting streets, avenues, etc., for a longer period than one year."

ARTICLES incorporating the National Gas and Electric Fixture Company were filed at Camden, N. J., on December 30, 1889. The capital stock of the concern is fixed at \$500,000, with 5 per cent. paid in. The incorporators are Messrs. Benjamin Thackara and Clement M. Biddle, of Philadelphia, H. C. Beck, of Brooklyn, N. Y., Jno. C. Cassidy, of East Orange, N. J., and Charles H. Fischer, of Mount Vernon, N. Y.

AT the annual meeting of the Covington (Ky.) Gas Company, no change was made in the executive management. Colonel Amos Shinkle, President of the Company, believes that 1890 is to be a great gas year.

A CORRESPONDENT, writing under date of December 29, 1889, from Kansas City, Mo., says: "Some months ago the question of removing mail boxes from the gas lamps in the city that are no longer in service because of the substitution of arc lights, came up. The posts could be removed to other parts of the city if it were not for the mail boxes attached to them, and it is but a mere matter of generosity on the part of the Gas Company that the posts have been allowed to be so used at all, even when the posts were a part of the public lighting equipment. Secretary Woolcott has informed the post office authorities that the Company would now like to transfer the posts, and has forwarded a list of the ones which it is desirable to remove, to the Postmaster. He will not insist on an immediate transfer, but will grant ample time for the removal of the mail boxes to other locations."

THE authorities of Denver, Col., headed by the Mayor, have been investigating the matter of the economy involved in the operation of municipal electric lighting plants. A portion of their researches is shown in the following replies received from localities where such plants have been in operation for a year or over:

Locality.	No. lights.	Cost of installation.	Annual cost per lamp.
Bay City, Mich.	120	\$30,280	\$39
Madison, Ind.	81	18,500	60
Topeka, Kan.	120	26,500	88
Little Rock, Ark. ...	95	27,000	75
Wichita, Kan.	150	55

At Bay City water power is availed of, steam being the motor in the other instances. The annual maintenance charges do not include anything for wear and tear or interest.

IN completion of our former mention of the explosion last month at the works of the Asheville (N. C.) Gas Company, in which two employees (Louis Guthrie and Wm. Gates) lost their lives, we may say that the testimony taken at the coroner's inquiry showed the accident to have resulted from the placing of a common lantern (with a light burning therein) at a point about 3½ feet from an open manhole in the gasholder crown—the gasholder having been let down for repairs—from which gas was still escaping. The verdict bluntly states that "the victims lost their lives because of the employment of incompetent men at the gas works." And the evidence more than bears out that arraignment.

CANTON, Ohio, pays at the rate of \$108 per annum for each arc light supplied on city account. The lamps are of the 2,000-candle power variety, and are suspended over the street centers. All-night lighting is the rule. Cleveland employs for the lighting of one square mile in the center of the city four towers (one of which is 250 feet in height, the others being 150 feet from the surface), one of which carries eight 4,000-candle power arcs, while the others carry 6 lamps, each of a like illuminating value—4,000 candles. In addition to these 78 arcs (2,000-candle power) are maintained at other points. A lighting table of 3,760 hours per annum is followed. For the mast lights the charge is 10½ cents per lamp per hour; for the others 3.7 cents per hour is the rate. It is said that the mast illumination gives the greater satisfaction.

A CORRESPONDENT writes: "In the last week in December 800 shares of the Fitchburg (Mass.) Gas Light Company's stock was sold at auction. The entire block was purchased by Mr. Geo. F. Fay, who secured the shares at par. This sale was the final act in the purchase by the Gas Company of the Wachusett Electric Light Company, the arrangements for which were made some time ago. The terms of the consolidation called for an increase in the capital stock, and the shares bought in by Mr. Fay will represent that increase.—OBSERVER."

AT a recent meeting of the City Council of East St. Louis, Mo., it was resolved to accept a proposition for the public lighting, submitted by the Citizens Electric Light and Power Company, under which 60 arcs (2,000-candle power) are to be maintained for a period of 3 years, at an annual charge of \$125 per light per annum. This decision is made in face of the fact that some years ago the authorities awarded a 30-year contract for the public lighting to the East St. Louis Gas Light Company, which contract will not expire until 1905. The Company will undoubtedly resort to the courts in the maintenance of its rights, but the contract-breakers are of the opinion that the Company is without redress, basing their belief on a decision of the State Supreme Court to the effect that no corporate body (in this sense meaning the municipal or local legislative authority) can legislate for a term longer than its own existence.

THE proprietors of the Davenport (Iowa) Gas Light Company have kept up with the procession in the year just closed. In the twelvemonth expenditures on plant account have amounted to \$29,000. Of this sum \$20,000 was put into new apparatus, while \$9,000 was apportioned to the street department. In the year 1½ miles of new mains were buried, and the balance of the system (27 miles) was thoroughly inspected and repaired. The Company is now in excellent shape for business, which is progressing most satisfactorily.

THE Pawtucket (R. I.) Common Council has amended its contract for public lighting with the Pawtucket Gas and Electric Light Company so that the 2,000-candle power arcs now supplied on the all-night schedule may be changed to half arcs.

SUPERINTENDENT HAYDEN, of the Fishkill (N. Y.) Gas Company, has taken advantage of the continued mild season to overhaul the main system, which, to say the least, was far from being a model one.

A ST. LOUIS newspaper says that the talk about introducing and attempting to pass another gas bill in lieu of the vetoed Branham-Hardesty imposition is ridiculous, and then adds the following simple truths: "No additional gas works are needed in this city. The old gas trust was a pretty tough thing for the people, but the remedy is not in the direction of new companies. The history of gas legislation shows that every new company eventually increases the cost of gas by compelling the old companies to absorb it and to pay interest on increased capitalization."

THE following is from the Clinton (Mo.) *Democrat*, dated the 2d inst.: "For nearly one year the *Democrat* proprietors have contemplated making an exchange of the 4½-horse power Bookwalter steam engine for a motor power for our newspaper and job presses which required less personal supervision, and at the same time suitable for all demands. A water motor was placed in position last summer, but its capacity was inadequate and again our steam engine performed its daily service. Recently, correspondence was re-opened with the Van Duzen Gas Engine Company, Cincinnati, O., for the purchase of an engine, which resulted in our placing an order by telegraph subject to 15 days trial. When the engine arrived a substantial stone foundation was put in and connection made to the gas meter. The engine has now been tested, and it gives us pleasure to say fills our highest expectations. It is simple in construction, economical in use of gas, develops full power, runs as

steadily as a clock, and has come to stay as a permanent fixture in our press room. Its floor space is 4 x 4 feet, height 6 feet, weight 1,600 lbs. With not more than one-half of its 4-horse power developed, it runs with ease our 33in. by 48in. Campbell press and Dexter folder, paster and cutter and 14½ by 22 Peerless and 9 by 12 Gordon job presses. To Mr. J. T. Marsh, Superintendent of the Clinton Gas, Coal and Coke Company, the *Democrat* is under lasting obligations for his many acts of courtesy, in placing the engine in position and for instructing us in its management. He has been a citizen of Clinton over 6 years, and is always at his post of duty. Our gas engine can be seen in operation every week day, from 4:30 to 5 P.M., and Mondays and Thursdays from 9 to 12 A.M.

ACCORDING to the annual report of the Superintendent of Public Lights (Mr. J. S. Read), there are now maintained at Pawtucket (R. I.) 156 electric, 110 gas and 147 oil lights, an increase of 18 gas lights and 7 oil lights over last year. During the year 2,160 chimneys in the oil lamps were broken, while 1,586 lights of glass were broken in the gas lanterns. The total expenditure was \$24,485, and the rebate on lights for the year was only \$162.64.

THE Walla Walla (Wash.) Gas and Electric Light Company is building a new engine and dynamo house. A new 100-horse power engine has also been ordered.

EVEN the Knights of Labor, of St. Louis, were opposed to the Bramham-Hardesty gas works grab, as shown by the action taken at a meeting of the Executive Committee of the Knights held on December 29. It must have been a decidedly tough grab when they were forced to attest its indigestibility.

THE Fuel Gas Improvement Company of Pittsburg, Pa., has been chartered.

A DÉSPATCH from Eau Claire, Mo., dated December 24th, says that during a violent *thunderstorm* on that date, a flash of lightning caused sad havoc to the wires of the local Brush electric company, and that a similar visitation burned out the McDonough incandescent plant.

IT is rumored that Colonel J. M. Thompson, well-known in St. Louis gas circles, may secure the appointment of United States Assistant Treasurer at St. Louis.

THE offices of the New Bedford (Mass.) Gas Company are now located in the Winslow Building. Another evidence of Mr. Taber's good taste.

SUPT. WHITEMORE, of the Bath (Me.) Gas Company, has completed the alterations at the works rendered necessary by the marked increase in the business of the Company.

THE Suburban Gas Company has been incorporated at Chicago by Messrs. R. Custer, M. Cameron and J. A. Griffin. It is capitalized in \$50,000.

THE annual meeting of the Trenton (N. J.) Gas Light Company will be held to-day.

THE Plattsburgh Light, Heat and Power Company has been incorporated, with a capital of \$100,000. The Trustees are A. L. Inman, Jno. H. Myers, G. M. Cole and S. A. Kellogg, of Plattsburgh, and H. M. Pierson, of Brooklyn.

IT is interesting to note how the increase in the number of gasoline street lighting contractors has gradually reduced the contract rates in various cities. Perhaps the best illustration of this is shown in the bids recently opened by the Council's Committee on Gas, Minneapolis, Minn., for supplying that city during the coming year with 2,000 or more gasoline street lamps. The bids are appended :

Bidder.	Per Post.
W. Forrestal & Co., St. Paul.....	\$17.20
Wheeler Reflector Company	15.60
Wheeler Gasoline	15.84
Jno. Van der Horck.....	16.96
Chester Oil Company.....	16.50
N. Western Globe Gas Light Company....	14.40

The lowest bid is something like \$5.60 per post under the present contract rate, the work being in the hands of the Wheeler Reflector Company.

THE contract between the St. Charles (Mo.) Gas and Coal Company and the authorities for the public lighting of that place expires on the 31st inst. It is probable that an attempt will be made to have the new contract based on a mixed system of gas and electric lighting.

THE Uniontown (Pa.) Electric Light and Power Company has been chartered. Capitalized in \$50,000.

THE Boston *Traveller* says that the gas people have met unsurmountable obstacles in their efforts to get control of the gas plants at Chelsea and Brighton, and as the indications now point, they are hardly likely to be successful in their move for the possession of the Waltham plant. Some of the stockholders have deposited their holdings in accordance with the request of the Directors, and under the agreement the Trustees are authorized to accept not less than \$140 per share. Very many of the stockholders are not, however, satisfied with this figure, and are not inclined to come into the arrangement. This latter decision would seem to be in line with wisdom, for we fail to understand how the Waltham property can be more valuable to outsiders than to those who are so intimately acquainted with its past history, present business and future prospects.

IN the meantime, mention of the Bay State syndicate brings to mind the fact that certain people well-informed in respect to Brooklyn (N. Y.) gas matters, assert that the companies of that city are likely to come under the control of Messrs. Addicks and his associates. Speaking on our own account we are not inclined to share this view, for we presume that such men as Mr. Morgan of the Nassau Company, and General Jourdan of the Fulton Municipal Company, know pretty well when they have a good thing, and know also how to take care of it.

TESTS of the illuminating power of Hartford (Conn.) gas, made by Prof. Mixer, the State Gas Inspector, on Dec. 31, shows an average lighting value of 17.80 candles.

FROM the Springfield (Mass.) *Republican* we take the following summary of the annual report of the Committee on Street Lighting for the past year.

"The Committee on Street Lights reports that the appropriation amounted to \$32,500, and the receipts, \$8 from the sale of globes; the expenditures amounted to \$27,437, leaving a balance unexpended of \$5,071. This does not include \$7,449 paid for electric light poles, which was taken from the money in the treasury not otherwise appropriated. The number of electric lights in use is 294, of gas 54, and of oil 349. There are 44 electric lights already established not as yet in operation—an increase in the number of lights established over last year of 283. The electric lights are furnished by the United Electric Light Company, of this city, under a five-year contract recently signed by this Committee, at a cost of little less than 23 cents a night for each light. The Committee believes the contract to be admirably adapted for practical use, containing no technical terms capable of a double meaning, and owing to many requests they have had from other cities for a copy, they have included this as a part of their report. The report then gives a sketch of the struggle which the Committee had to secure the new contract. After finding at the beginning of the year that the price was exorbitant, and getting permission of the City Council, the Committee served notice, February 22, on the United Electric Light Company to that effect. Then the Committee endeavored to secure an estimate from the local Company. Being unable to obtain reasonable figures an order was introduced in the City Council asking leave to advertise for proposals for lighting the city; but the Aldermen tabled the measure. Almost discouraged the Committee began to agitate the question of municipal lighting, especially from a financial standpoint. The Committee did not favor it as expedient, and except as having a tendency to induce the local Company to accept a reasonable offer. It had the desired effect, for May 22 a contract with the United Electric Light Company was signed, they agreeing to furnish 300 half-arc electric lights for \$83½ a year for each light, a very satisfactory reduction from the former price of \$219. This investigation was carried on at an expense of less than \$20 to the city. Under the contract the city is required to furnish the lamp poles. The Committee endeavored to secure chestnut poles, but had to get of the Massachusetts Construction Company, of Boston, Georgia hard pine poles, which are believed to be equally durable. The work of setting the poles was also done by this Company. The Committee believes the contract to be very fair and reasonable, and recommends that a strict observance should be insisted on by the city. It is also recommended that the lights be tested from time to time, for electric lights, to be a success, must be of the specified candle power. Owing to the irregular streets and the unnecessary number of shade trees on many of them the Committee found it very difficult to derive the best results from lights in many localities. This has been obviated by using mast arms placing lights over the street. The arms used by the city are two patterns, the Brady, the longer in use and giving general satisfaction, and the other, the Russell, a much neater and lighter arm, equally satisfactory. It is recommended that the electric lights be increased so as to dispense as far as possible with the gas and oil lights, especially on the principal streets, where they serve the double purpose of giving light and protection. In June the Committee advertised for proposals for the care of the gas and oil lights, but owing to the greatly increased number of electric lights, no bids were received. T. W. Hamilton has continued the work at the old price, 2 cents a night for gas, and 2½ cents for oil lights, although he is under no contract. The Committee believes that the time has arrived when the city should establish by ordinance a superintendent of street lights, whose duty shall be to carefully inspect all electric lights and report any irregularities to the Committee, also to have supervision of all other lights of the city."

Advertisers Index.

GAS ENGINEERS.	
Jos. R. Thomas, New York City	60
Wm. Henry White, New York City	65
Wm. Mooney, New York City	60
William Gardner, Pittsburg, Pa.	60
Fred. Bredel, N. Y. City	59
GAS AND WATER PIPES.	
Gloucester Iron Works, Phila., Pa.	60
Mellert Foundry and Machine Co., Reading, Pa. (John Fox, Selling Agent, N. Y.)	60
Ohio Pipe Co., Columbus, Ohio	60
M. J. Drummond, New York City	60
R. D. Wood & Co., Phila., Pa.	62
Warren Foundry & Machine Co., New York City	60
Donaldson Iron Co., Emaus, Pa.	60
Dennis Long & Company, Louisville, Ky.	60
A. & W. S. Carr Co., New York City	18
GAS WORKS APPARATUS AND CONSTRUCTION.	
James R. Floyd & Sons, New York City	63
Continental Iron Works, Greenpoint, L. I.	63
Deily & Fowler, Phila., Pa.	63
Kerr Murray Mfg. Co., Fort Wayne, Ind.	51
Stacey Mfg. Co., Cincinnati, Ohio	63
Bartlett, Hayward & Co., Baltimore, Md.	61
Morris, Tasker & Co., Limited, Phila., Pa.	61
Davis & Farnum Mfg. Co., Waltham, Mass.	19
R. D. Wood & Co., Phila., Pa.	62
Bouton Foundry Co., Chicago, Ills.	63
Smith & Sayre Manufacturing Co., New York City	63
Fred. Bredel, N. Y. City	59
United Gas Improvement Co., Phila., Pa.	53
Henry Pratt & Co., Chicago, Ill.	59
National Gas Light and Fuel Co., Chicago, Ills.	54
Simpkin & Hillyer, Richmond, Va.	49
PROCESSES.	
National Gas Light and Fuel Co., Chicago, Ills.	54
Bartlett, Hayward & Co., Baltimore, Md.	61
Wm. Henry White, N. Y. City	65
United Gas Improvement Co., Phila., Pa.	53
Henry Pratt & Co., Chicago, Ill.	59
INCLINED RETORTS.	
Laclede Fire Brick Manuf'g Co., St. Louis, Mo.	51
GASHOLDER TANKS.	
W. C. Whyte, New York City	54
J. P. Whittier, Brooklyn, N. Y.	49
GASHOLDER PAINT.	
The Government Waterproof Paint Co., Boston, Mass.	49
RETORTS AND FIREBRICK.	
J. H. Gautier & Co., Jersey City, N. J.	58
B. Kreisler & Sons, New York City	58
Adam Weber, New York City	58
Laclede Fire Brick Manuf'g Co., St. Louis, Mo.	58
Brooklyn Retort and Fire Brick Works, Brooklyn, N. Y.	58
Borgner & O'Brien, Phila., Pa.	58
James Gardner, Jr., Pittsburgh, Pa.	58
Henry Maurer & Son, New York City	59
Chicago Retort and Fire Brick Co., Chicago, Ills.	58
Baltimore Retort and Fire Brick Co., Baltimore	58
Oakhill Gas Retort and Fire Brick Co., St. Louis, Mo.	58
SCRUBBERS AND CONDENSERS.	
G. Shepard Page, New York City	52
R. D. Wood & Co., Phila., Pa.	62
REGENERATIVE FURNACES.	
Bartlett, Hayward & Co., Baltimore, Md.	61
Fred. Bredel, New York City	59
Chicago Retort and Firebrick Co., Chicago, Ills.	58
Wm. Henry White, N. Y. City	65
J. H. Gautier & Co., Jersey City, N. J.	59
GAS GOVERNORS.	
Connelly & Co., New York City	55
Fred. Bredel, N. Y. City	59
Friedrich Lux, London, England	48
SELF-SEALING MOUTHPIECE DOORS.	
Smith & Sayre Mfg. Co., New York City	59
TAR AND CARBONIC ACID EXTRACTOR.	
Geo. Shepard Page, N. Y. City	20
PURIFYING MACHINES.	
C. & W. Walker, London, England	18
CEMENTS.	
C. L. Gerould & Co., Brooklyn, N. Y.	58
GAS ENRICHERS.	
Standard Oil Co., Cleveland, Ohio	64

GAS METERS.	
John J. Griffin & Co., Phila., Pa.	66
American Meter Co., New York and Philadelphia	67
The Goodwin Gas Stove and Meter Co., Philadelphia, Pa.	67
Helme & McLhenny, Phila., Pa.	67
D. McDonald & Co. Albany, N. Y.	67
Nathaniel Tufts, Boston, Mass.	66
Maryland Meter and Manufacturing Co., Baltimore, Md.	34
John Hillen, Brooklyn, N. Y.	66

EXHAUSTERS.	
P. H. & F. M. Roots, Connersville, Ind.	62
Smith & Sayre Manufacturing Co., New York City	63
Wilbraham Bros., Philadelphia, Pa.	55
Connelly & Co., New York City	55

GAS COALS.	
Penn Gas Coal Co., Phila., Pa.	65
Perkins & Co., New York City	64
Newburgh Orrel Coal Co., Baltimore Md.	65
Despard Coal Co., Baltimore, Md.	65
Chesapeake and Ohio R. R. Coal Agency, N. Y. City	65
Westmoreland Coal Company, Phila., Pa.	65
J. & W. Wood, New York City	64

CANNEL COALS.	
Perkins & Co., New York City	64
J. & W. Wood, New York City	64

VALVES.	
Ludlow Valve Manufacturing Co., Troy, N. Y.	56
John McLean, New York City	56
Chapman Valve Manufacturing Co., Boston, Mass.	56
R. D. Wood & Co., Phila., Pa.	62
A. & W. S. Carr Co., New York City	18

GAS ENGINES.	
Schleicher, Schumm & Co., Phila., Pa.	68
Clerk Gas Engine Co., Phila., Pa.	56
Van Duzen Gas Engine Co., Cincinnati, Ohio	56

ENGINES AND BOILERS.	
Jarvis Engineering Co., Boston, Mass.	55
Bail Engine Co., Erie, Pa.	49
Westinghouse Machine Co., Pittsburgh, Pa.	55

GAS LAMPS.	
G. Shepard Page, New York City	24
Standard Gas Lamp Co., Phila., Pa.	49
Welshach Incandescent Gas Light Co., Phila., Pa.	50
The Siemens-Lungren Company, Philadelphia, Pa.	50

PURIFIER SCREENS.	
John Cahot, New York City	56
Bartlett, Hayward & Co., Baltimore, Md.	56

GAS STOVES.	
American Meter Co., New York and Philadelphia	57
The Goodwin Gas Stove and Meter Co., Phila. Pa.	56
George M. Clark & Company, Chicago, Ills.	50

STREET LAMPS.	
J. G. Miner, Morrisania, New York City	49
Bartlett Street Lamp Man'g Co., New York City	49

BURNERS.	
C. A. Gefroerer, Phila., Pa.	64
H. W. Rappleye, Phila., Pa.	901

STEAM BLOWER FOR BURNING BREASE.	
H. E. Parson, New York City	56

PURIFYING MATERIAL.	
Connelly & Co., New York City	55
Friedrich Lux, London, England	48
Edgewater Lime Works, Edgewater, N. J.	48

COKE CRUSHER.	
C. M. Keller, Columbus, Ind.	65

ELECTRICAL APPARATUS.	
Wm. Henry White, N. Y. City	65

SOLVENTS.	
Maas & Waldstein, New York City	49

Position Wanted

As Superintendent or Assistant of a Gas Works,
By a man who can give the best of references. Thoroughly understands the manufacture and distribution of gas and the construction of works. Address
758-3 "C.," care this Journal.

FOR SALE,

Otto Gas Engine, 15-Horse Power,
With Counter Shafting, Belting, etc. Completely fitted for running electric lights. Used only 10 days; satisfactory reasons for selling. Address
761-2 "C. B.," Post Office Box 5104, Boston, Mass.

FOR SALE,

All the Appliances Necessary for the Passing of 100,000 Cubic Feet of Coal Gas per Day.
Now in operation at Stamford, Conn. Reason of sale, incapacity of present plant. For further information address
759-4 STAMFORD GAS LT. CO., Stamford, Conn.

FOR SALE.

A Complete Water Gas Plant.
60,000 Cu. Ft. Daily Capacity.

Fully equipped; all the latest improvements; includes Generator, Purifiers, and Holder. Can be removed to any part of the country, and set up at small cost. For further information apply to BRADFORD GAS LT. & HEATING CO., Dunkirk, N. Y.

GAS WORKS FOR SALE.

A CONTROLLING INTEREST IN SEVERAL

Interior California Coal Gas Plants,

now paying handsomely, are offered on very reasonable terms. This is an exceptionally good opportunity for practical gas men of limited means, wishing to remove to a mild and healthful climate, to acquire an established and paying business. Particulars given and full investigation solicited.

760-1f SECRETARY, 123 Beale Street, San Francisco, Cal.

Fuel and Its Applications.

By E. J. MILLS, D.Sc. F.R.S., and F. J. ROWAN, C.E., assisted by others, including Mr. F. P. Dewey, of the Smithsonian Inst., Wash., D. C.

7 PLATES, AND 607 OTHER ILLUSTRATIONS. ROYAL OCTAVO, PAGES XX, 802. HANDSOME CLOTH, \$7.50.

A. M. CALLENDER & CO., 42 Pine St., N. Y.

GEROULD'S

System Gas Bookkeeping.

Approved and adopted by many of the prominent Gas Engineers of the Country.

Sample Sheets and Price-List furnished free on application to

L. P. GEROULD, - - Mendota Ill.

EDGEWATER LIME WORKS

Chas. F. McKenna, Proprietor.

SHELL LIME.

Lime by the Cargo for Gas Purification.

EDGEWATER, BERGEN CO., N. J.

Write for Testimonials and Prices.

FRIEDRICH LUX,

Ludwigshafen am Rhein and London.

Lux Mass

GAS GOVERNORS,

Gas Balance.

PATENTS.

FRANKLIN H. HOUGH
Solicitor of American & Foreign Patents.

925 F. ST., WASHINGTON, D. C.

(NEAR U. S. PATENT OFFICE.)

Personal attention given to the preparation and prosecution of applications for Letters Patent. All business before the U. S. Patent Office attended to for moderate fees. **No Agency in the United States possesses superior facilities for obtaining Patents**, or for ascertaining the patentability of inventions. Copies of patents furnished for 25 cents each. Correspondence solicited.

6 PER CENT.

First Mortgage Bonds

ON GAS WORKS

SITUATED IN GROWING WESTERN TOWNS.

Principal and Interest Guaranteed.

INTEREST SEMI-ANNUALLY.

For sale by the undersigned, who will furnish all necessary information regarding them.

JOS. R. THOMAS, 42 Pine St., N. Y. City.

Simpkin & Hillyer

RICHMOND, VA.

MANUFACTURERS OF

Gas Works Apparatus

BENCH CASTINGS, CONDENSERS,

Scrubbers, Purifiers, Dry Center Seals,

FOUR-WAY VALVES, GAS VALVES,

SULPHATE OF AMMONIA APPARATUS, TANKS, ENGINES, BOILERS, PUMPS, ETC., ETC.

Plans, Specifications and Estimates furnished for new works, or alteration of old works. Correspondence solicited. Works, Newport News, Va.

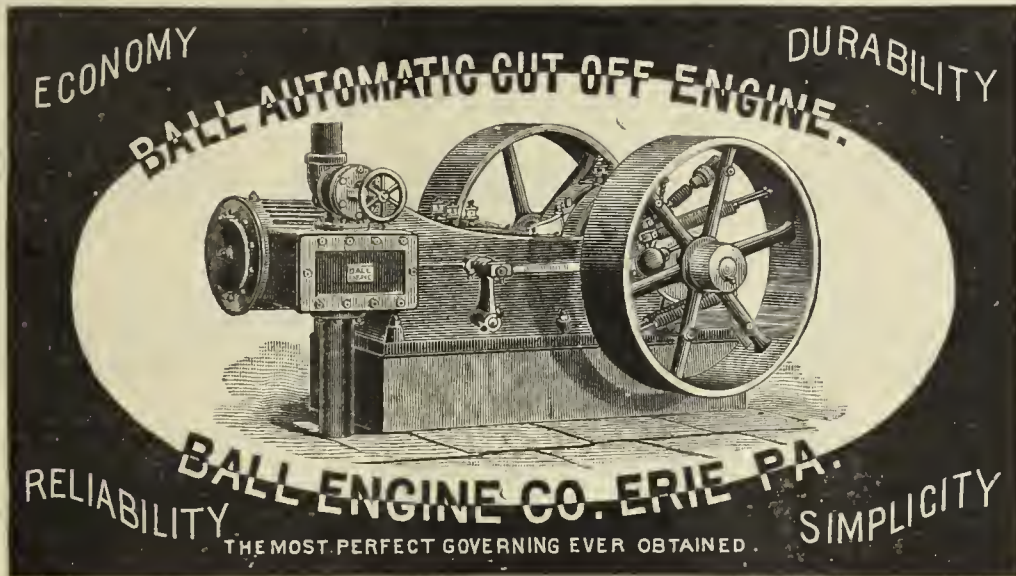

Bartlett Street Lamp Mfg. Co.

MANUFACTURERS OF

Globe Lamps,

FOR

Streets, Parks, Public Buildings, Railroad Stations, etc.

LAMP POSTS

A Specialty.

Office and Salesroom,

40 & 42 COLLEGE PLACE, - - N. Y. CITY.

Gas Companies and others intending to erect Lamps and Posts will do well to communicate with us.



PHILADELPHIA. NEW YORK. CHICAGO.
STEPHEN A. MORSE, President. EDWIN F. MORSE, Secretary.
GODFREY REBMANN, Vice-Pres. CARLTON M. WILLIAMS, Treas.
STANDARD GAS LAMP CO.,
Main Office, 411 Cherry St. Factory, 1101, 1103, 1105 Frankford Av.
PHILADELPHIA, PA.

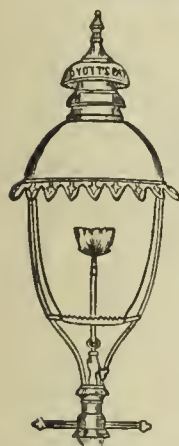

No. 29 Champion.

It is to the interest of Gas Companies and Cities to double the efficiency of the light on streets by using Dyott's Patent "CHAMPION" LAMPS. They save 50 per cent. over others in cost of repairs, are ornamental, and indestructible except by violence.
Our Patent System of Instantaneously Lighting Gas (without electricity), for Railroad Depots is unequalled.
Dyott's High Candle Power Burner is a very superior lamp where a concentrated and brilliant light is wanted in Hotels, Stores, Depots, etc.
Special Drawings furnished and Estimates cheerfully given, either from Architects, Engineers, or our Draughtmen's Plans.
We manufacture every description of Plain and Ornamental Lamps, Posts, Brackets, Clusters, etc. Correspondence solicited.



Standard Street Lamp

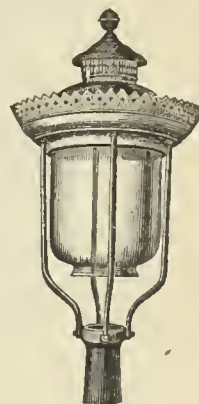
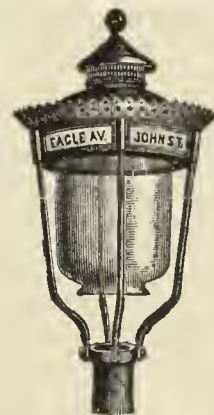

The Miner Street Lamps.

Jacob G. Miner,

No. 823 Eagle Ave., New York, N. Y.

GASHOLDER PAINT.

Use Only

THE GOVERNMENT WATERPROOF PAINT.

Proof against Ammonia, and Absolutely Waterproof. Send for Prices and Particulars.

THE GOVERNMENT WATERPROOF PAINT CO., 122 Milk Street, Boston, Mass.

(Patented.)

IMPORTANT!

(Patented)

NEW SOLVENT FOR GAS PIPE DEPOSITS.

Economical and Effective.

MAAS & WALDSTEIN, 44 Trinity Place and 81 Greenwich St., N. Y.

Gasholder Tanks & Gas Works Masonry Complete.

PLANS PREPARED AND ESTIMATES FURNISHED AT SHORT NOTICE.

J. P. WHITTIER, - - 499 Wythe Av., Brooklyn, N. Y.

The Gordon Portico Lamp.

A successful Competitor of the Arc Electric Light for lighting Store Fronts, Show Windows, Depots, Railway Sheds, etc., etc.

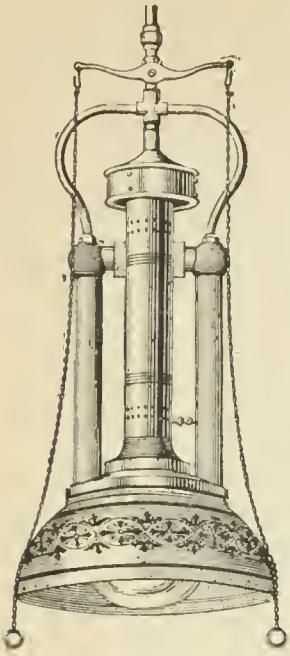

Gordon Portico Lamp.

The Gordon Street Lamp.

A Successful Competitor of the Arc Electric Light for lighting Streets, etc., etc.

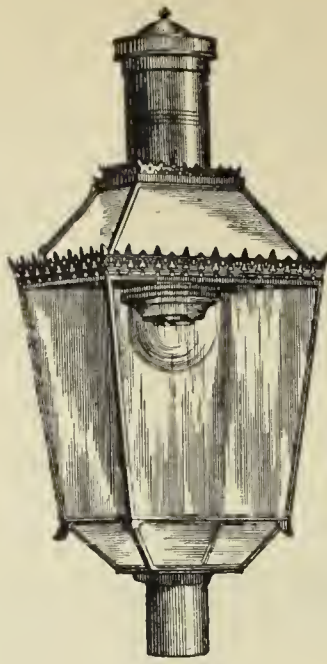

Gordon Street Lamp.

The Lungren Lamp.

A Successful Competitor of the Incandescent Electric Light for Interiors, etc. Is especially applicable for the lighting of Offices, Stores, Factories, Mills, Show Windows, Libraries, and all situations where an increased illumination is desired.

More than 25,000 Lungren Lamps are now in use. Testimonials, references, or any desired information will be cheerfully given.

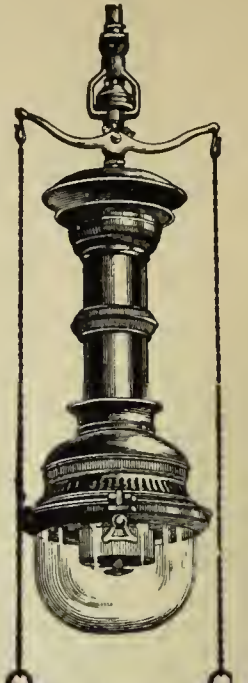

Lungren Lamp.

THE SIEMENS-LUNGREN CO., N.E. Cor. 21st St. & Washington Av., PHILADELPHIA.

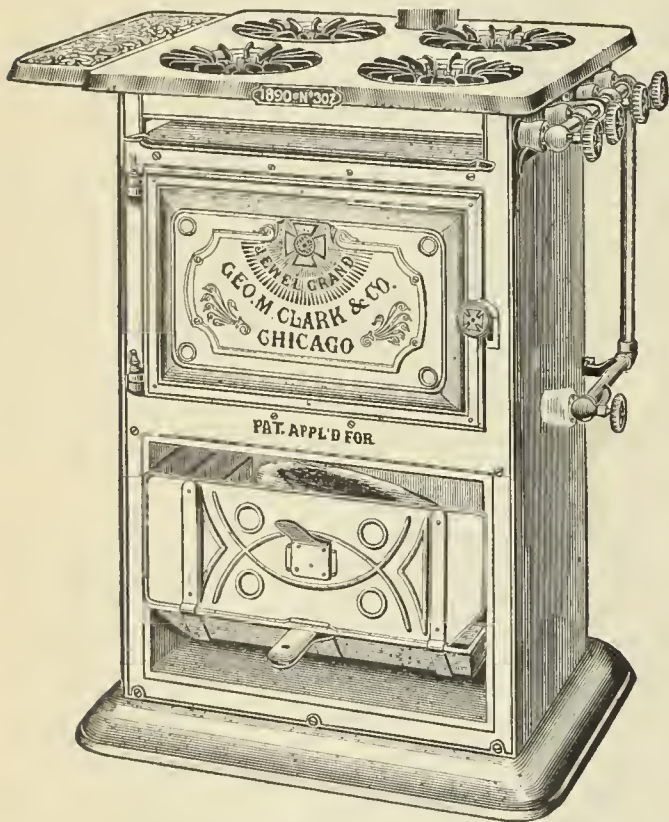

JEWEL GAS STOVES

MANUFACTURED BY

GEORGE M. CLARK & COMPANY,

Nos. 157 & 159 Superior Street, - - - Chicago, Ill

EVERY CONCEIVABLE SIZE AND STYLE,

Ranging in Prices from \$1.50 to \$30.00.

WE USE NO GAS COCKS.

All Flames are Regulated by a Direct Needle Valve.

The JEWEL

IS THE

Only Well-Made Gas Stove on the Market.

Write for our 1890 Catalogue and see for yourself.

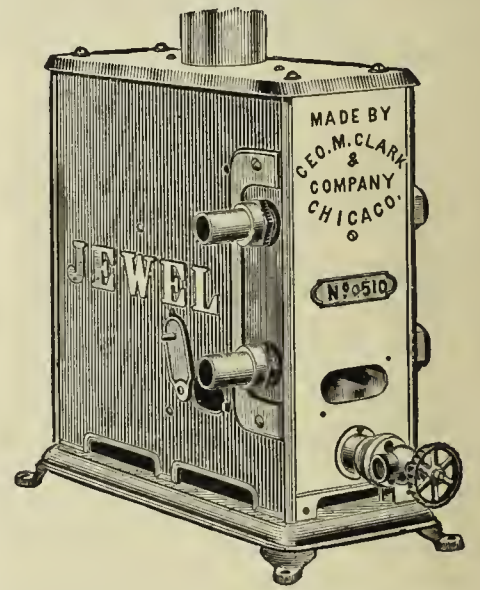

WELSBACH SYSTEM OF Incandescent Gas Lighting.

OFFICE, DREXEL BUILDING, PHILA., PA.

At the Fall Session of the Board of Supervisors of Winnebago County, held at the County Court House, Oshkosh, Wis., Nov. 26, 1889, the report submitted by Mr. C. W. Cook, Chairman of the Committee on Public Buildings, recommending the use of the Welsbach Incandescent Gas Burner in the Buildings under their charge, was unanimously adopted, because of the extreme economy in the consumption of Gas and the superior character of the light obtained.

THIS SPACE
WILL BE
Occupied Next Month by the
KERR MURRAY MFG. CO.
FORT WAYNE, IND.
**GAS WORKS
APPARATUS
AND
HOLDERS.**

LACLEDE FIRE BRICK MANUFACTURING COMPANY,

ST. LOUIS, MO.

Exclusive Agents in the United States

FOR THE

Coze System of Inclined Retorts.

IT IS THE COMING BENCH
FOR MAKING COAL GAS.

*It will Save from 50 to
60 per ct. in Labor.*

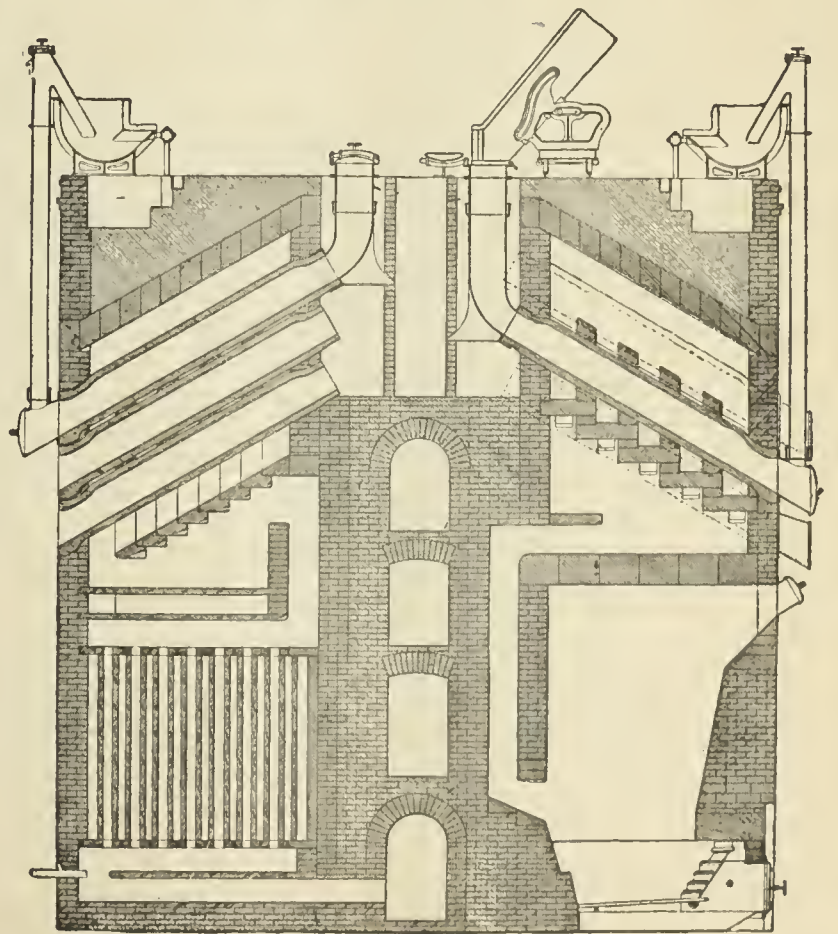
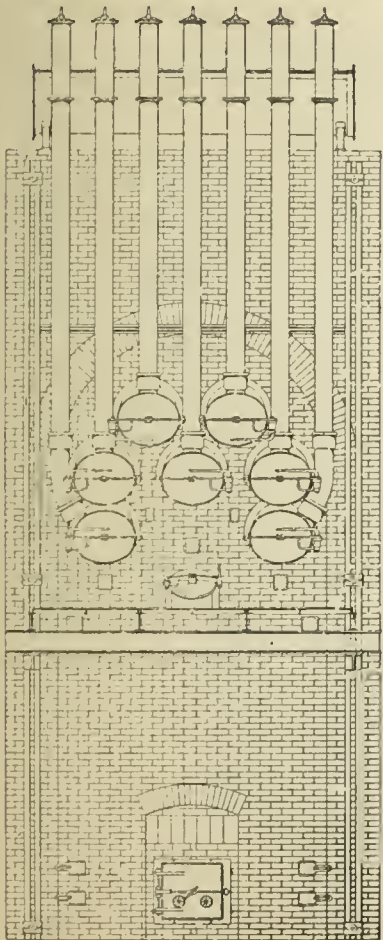

ESTIMATES AND PLANS FURNISHED BY THE

LACLEDE FIRE BRICK MFG. CO., ST. LOUIS, MO.

KIRKHAM, HULETT & CHANDLER, LIMITED.

PATENT "STANDARD" WASHER-SCRUBBERS
Erected and in course of construction at present date:

Capacity. Cubic feet per day.	Capacity. Cubic feet per day.	Capacity. Cubic feet per day.	Capacity. Cubic feet per day.
Altrincham..... 600,000	Dublin..... 3,000,000	LONDON—Continued.	Ober Schlesian..... 1,500,000
Adelaide..... 800,000	Dowlais..... 100,000	Shoreditch..... 2,500,000	Otto & Co.'s Coke Works..... 1,500,000
Aldershot..... 200,000	Douai..... 500,000	Pancras..... 1,500,000	Plymouth..... 2,000,000
Allegheny, U. S. A..... 1,000,000	Denton..... 500,000	"..... 1,500,000	Parramatta, N. S. W..... 100,000
Ashton-under-Lyne..... 1,250,000	Derby, U.S.A. 350,000	Pimlico..... 2,000,000	Prescott..... 150,000
Amsterdam..... 1,500,000	Denver, " 500,000	Nine Elms..... 3,000,000	Providence, U.S.A. 750,000
"..... 1,500,000	"..... 1,000,000	"..... 3,000,000	"..... 750,000
Annaberg..... 200,000	Dusseldorf..... 750,000	South Metropolitan Co:—	Plauen..... 300,000
Arcachon..... 100,000	"..... 500,000	Greenwich..... 3,000,000	"..... 300,000
Animal Charcoal Co..... 200,000	Dumfries..... 250,000	Woolwich..... 400,000	Portsmouth..... 2,500,000
Altoona, U.S.A. 350,000	Dunedin, N.Z..... 400,000	Vauxhall..... 3,000,000	"..... 2,500,000
Buxton..... 250,000	Darlington..... 1,250,000	"..... 3,000,000	Pittsburgh, U.S.A. 1,500,000
Bradford..... 1,000,000	Detroit, U.S.A. 750,000	Lea Bridge..... 300,000	Portland, " 560,000
"..... 1,250,000	Edinburgh..... 1,500,000	West Ham..... 1,500,000	Pawtucket, " 500,000
"..... 1,250,000	"..... 2,000,000	Leeds..... 2,000,000	Quebec 250,000
"..... 1,250,000	Enfield..... 300,000	"..... 3,000,000	Radcliffe..... 750,000
"..... 1,000,000	Essen..... 300,000	"..... 3,000,000	Rouen..... 250,000
"..... 1,000,000	Elbing..... 150,000	"..... 3,000,000	Ramsgate..... 1,000,000
"..... 3,000,000	Falmouth..... 150,000	"..... 2,000,000	Reigate..... 200,000
Bremen..... 150,000	Frankfort..... 300,000	"..... 3,000,000	Richmond, U.S.A. 250,000
Baltimore, U.S.A. 1,000,000	Farnworth..... 400,000	"..... 3,000,000	Roxbury, " 500,000
"..... 1,000,000	Fenton..... 400,000	"..... 3,000,000	Runcorn Soap Co..... 20,000
"..... 1,000,000	Friedenshutte..... 500,000	"..... 2,000,000	Rockhampton, N. S. W..... 125,000
Balmain, N.S.W..... 125,000	Furth..... 400,000	Leominster..... 150,000	Richmond..... 1,500,000
Bishops Stortford..... 150,000	Freiburg..... 200,000	Leiden..... 560,000	Reading..... 2,000,000
Blackpool..... 400,000	Goole..... 250,000	"..... 600,000	Reichenbach..... 200,000
Brussels..... 1,250,000	Glossop..... 300,000	Liverpool..... 2,000,000	Salford..... 1,750,000
"..... 1,250,000	Guildford..... 300,000	"..... 2,000,000	"..... 1,750,000
"..... 750,000	Gloucester..... 1,250,000	"..... 2,000,000	"..... 1,750,000
"..... 1,250,000	Gera..... 300,000	"..... 2,000,000	Smethwick..... 750,000
Banbury..... 250,000	Grafton, N.S.W..... 100,000	"..... 2,000,000	Sydney, N. S. W..... 1,000,000
Birmingham..... 5,000,000	Grieg..... 300,000	"..... 3,000,000	"..... 1,000,000
Birkenhead..... 2,500,000	Georgetown, U.S.A. 250,000	Lincoln..... 1,000,000	"..... 2,500,000
Blackburn..... 1,500,000	Gluckauf..... 200,000	"..... 600,000	"..... 50,000
Bochum..... 600,000	Heywood..... 600,000	Lowell, U. S. A. 1,000,000	"..... 50,000
Burntisland..... 250,000	Hollywood..... 125,000	Louisville " 1,500,000	Sunderland..... 1,500,000
Boston, U.S.A. 2,000,000	Huy..... 70,000	Long Eaton..... 500,000	St. Josephs, U.S.A. 250,000
Brisbane..... 1,500,000	Harrow..... 250,000	Lilie..... 900,000	Spa..... 100,000
"..... 300,000	Harrogate..... 250,000	"..... 450,000	Sevenoaks..... 300,000
Burton-on-Trent..... 1,500,000	Halstead..... 150,000	"..... 750,000	St. Petersburg..... 2,000,000
Barcelona..... 350,000	Heilbronn..... 200,000	"..... 250,000	"..... 1,500,000
Barking..... 100,000	Havana, Cuba 750,000	"..... 250,000	St. Louis, U.S.A. 2,000,000
Baerlien & Co..... 20,000	Hastings..... 1,500,000	Luckenwalde..... 330,000	"..... 2,000,000
"..... 20,000	Huddersfield..... 300,000	Liegwitz..... 300,000	"..... 1,000,000
Bombay..... 400,000	"..... 750,000	Lincoln, U. S. A. 250,000	Laclede 1,000,000
Buffalo, U.S.A., Mutual 750,000	"..... 1,500,000	Lawrence " 500,000	Silesian Coal Co..... 600,000
"..... Citizen 500,000	Hof..... 200,000	Lynn " 300,000	San Francisco, U.S.A. 2,000,000
Brookline, U.S.A. 500,000	Hampton Wick..... 500,000	Lyons..... 1,500,000	"..... 2,000,000
Bergen..... 350,000	Heckmondwicke..... 500,000	Maidstone..... 1,000,000	Sheepbridge Coal Co..... 40,000
Berlin..... 1,250,000	Haverfordwest..... 100,000	Marseilles..... 1,500,000	Stettin..... 200,000
Bournemouth..... 1,000,000	Halifax, N.S. 350,000	"..... 1,500,000	Singapore..... 300,000
Bridgeport, U.S.A. 500,000	Hamm..... 200,000	Mons..... 500,000	Sutton..... 500,000
Brunswick..... 300,000	Halle..... 400,000	Malines..... 250,000	Tonbridge..... 150,000
Beck & Co., St. Louis 100,000	Heidelberg..... 300,000	Melbourne..... 1,500,000	Tipton..... 400,000
Barmen Rittershausen..... 600,000	Hartford, U.S.A. 1,000,000	"..... 1,500,000	Tottenham..... 1,000,000
Bexhill..... 125,000	Ilkeston..... 300,000	"..... 1,500,000	Toledo, U.S.A. 750,000
Brooklyn, U.S.A. 1,000,000	Inverness..... 250,000	"..... 1,500,000	Toronto 1,000,000
"..... Nassau 1,000,000	Ilkley..... 200,000	"..... 1,500,000	Uxbridge..... 300,000
Brunner, Mond & Co..... 400,000	Ilford..... 100,000	Manchester..... 2,500,000	Valparaiso 500,000
Cheltenham..... 2,000,000	Kingston-on-Hull..... 400,000	Middleton..... 400,000	West Bromwich..... 1,000,000
Cannes..... 200,000	Kidderminster..... 750,000	Manley, N. S. W..... 100,000	Willenhall..... 250,000
Croydon..... 1,500,000	Kidsgrove..... 100,000	Minneapolis, U. S. A. 750,000	Weston-super-Mare..... 500,000
Copenhagen..... 200,000	Konigberg..... 1,000,000	Magdeburg..... 300,000	Waltham..... 150,000
Clevedon..... 200,000	King's Lynn..... 300,000	Memphis, U. S. A. 750,000	Wormwood Scrubs..... 300,000
Columbus, U.S.A. 500,000	LONDON:—	Nottingham..... 1,250,000	Williamsburg, U.S.A. 600,000
Cincinnati, " 1,500,000	The Gaslight and Coke Co. :	"..... 2,500,000	"..... 600,000
"..... 1,500,000	Beckton..... 1,250,000	"..... 2,500,000	Wellington..... 150,000
Chicago 3,000,000	"..... 1,250,000	"..... 2,000,000	Warwick..... 300,000
"..... 1,000,000	"..... 1,250,000	"..... 1,500,000	Wheeling, U.S.A. 500,000
"..... 1,000,000	"..... 1,250,000	"..... 2,000,000	Walker..... 300,000
Chemnitz..... 1,000,000	"..... 1,250,000	Newport, U.S.A. 430,000	Westgate..... 100,000
Crewe..... 1,250,000	"..... 1,250,000	Newmarket..... 150,000	Wilmington, U.S.A. 500,000
Colonial Gas Works Co..... 100,000	"..... 1,250,000	Newark, U.S.A. 680,000	Windsor, N. S. W..... 100,000
Cadiz..... 300,000	"..... 2,500,000	Northfleet..... 200,000	Wolverton..... 100,000
Charlottenburg..... 600,000	"..... 2,500,000	New York, U.S.A. 2,000,000	Wellington, N. Z..... 250,000
Dudley..... 750,000	Silvertown..... 1,000,000	Nice..... 600,000	Whitchurch..... 175,000
Driffeld..... 100,000	Bromley..... 2,000,000	Newcastle, N. S. W..... 200,000	Washington, U.S.A. 2,000,000
Dukenfield..... 500,000	"..... 1,500,000	Numea, "..... 100,000	Wallasey..... 750,000
Dover..... 750,000	"..... 1,500,000	Namur..... 250,000	Weimar..... 150,000
"..... 1,000,000	"..... 1,500,000	Newark..... 350,000	Wurzen..... 200,000
Deal..... 200,000	"..... 2,000,000	Oldbury..... 500,000	Worcester, U.S.A. 750,000
Derby 1,500,000	"..... 1,500,000	Otley..... 200,000	Yeadon..... 500,000
		Oswestry..... 250,000	Yeovil..... 250,000

SOLE AGENT FOR WESTERN HEMISPHERE,
GEO. SHEPARD PAGE, 69 WALL STREET, NEW YORK

THE UNITED GAS IMPROVEMENT CO.

DREXEL BUILDING, PHILADELPHIA.

OFFICERS:

WILLIAM W. GIBBS, President.

GEORGE PHILLER, Vice-President.

SAM'L T. BODINE, Gen'l Manager.

RANDAL MORGAN, Gen'l Counsel.

EDWARD C. LEE, Sec'y and Treas.

ALEX. C. HUMPHREYS, Gen'l Supt.

WALTON CLARK, Ass't Gen'l Supt.

H. H. EDGERTON, Chem. and Eng'r.

DIRECTORS:

GEORGE PHILLER,

THOMAS DOLAN

HENRY C. GIBSON,

WM. T. CARTER,

WILLIAM G. WARDEN,

SAM'L T. BODINE.

BUILDERS, LESSEES AND PURCHASERS OF

➤ GAS WORKS. ➤

Orders solicited from Large Cities, Small Towns, Mills, Institutions, from all who want more Light for Less Money.

NATIONAL GAS LIGHT AND FUEL COMPANY,

No. 218 La Salle Street, Chicago.

THE SPRINGER SYSTEM

OF

Fuel and Illuminating Water Gas Works.

REFERENCES.

People's Gas Lt. & Coke Co.. Chicago, Ill.
 Illinois Light, Heat & Power
 Co..... Chicago, Ill
 Elgin National Watch Co... Elgin, Ill.
 C. R. I. & P. R. R. Shops.. Chicago, Ill.
 Decatur Gas Lt & Coke Co.. Decatur, Ill.
 Niles Gas Light Co Niles, Mich.
 Newton Illuminating Co... Newton, Kansas.
 Wellington Light & Heat Co.. Wellington, Kansas.
 Chippewa Falls Gas Lt. Co.. Chippewa Falls, Wis.
 Elkhart Gas Lt & Coke Co.. Elkhart, Ind.
 Madison City Gas Light Co. Madison, Wis.
 South Bend Gas Light Co.. South Bend, Ind.
 Sheboygan National Gas Co. Sheboygan, Wis.
 Salina Gas Light Co..... Salina, Kansas.
 The Rathbun Co Deseronto, Prov. Ont.
 Jefferson City Gas Lt. Co .. Jeffersou City, Mo.
 Mankato Gas Light Co..... Mankato, Minn.
 Lima Gas Light Co. Lima, Ohio.

Minneapolis Gas Light and
 Coke Co..... Minneapolis, Minn.
 Bellevue Water and Fuel } Bellevue, Campbell
 Gas Light Co..... } County, Ky.
 Bucyrus Gas Lt. & Fuel Co. Bucyrus, Ohio.
 Morris Gas Co..... Morris, Ill.
 Los Angeles Gas Co..... Los Angeles, Cal.
 San Diego Gas Fuel & Elec-
 tric Lt. Co..... San Diego, Cal.
 Sioux Falls Gas Co..... Sioux Falls, Dak.
 Dakota Gas and Fuel Co. . Grand Forks, Dak.
 St. Johns Mutual Gas Co... St. Johns, Mich.
 Stillwater Gas Light Co... Stillwater, Minn.
 St. Paul Gas Light Co St. Paul, Minn.
 Emporia Electric and Gas
 Light Co..... Emporia, Kas.
 Van Wert Gas Light Co. . . Van Wert, Ohio.
 Lansing Gas Light Co..... Lansing, Mich.
 San Francisco Gas Lt. Co. . San Francisco, Cal.

Shelbyville Gas Light Co. . Shelbyville, Ind.
 Great Falls Gas Light Co.. Great Falls, N. H.
 Belleville Gas Co..... Belleville, Ontario
 Rochester Lt. and Fuel Co.. Rochester, Minn.
 Northwestern Gas Light and
 Coke Co..... Evanston, Ill.
 Lincoln Gas Light Co..... Lincoln, Neb.
 Davenport Gas Light Co ... Davenport, Iowa.
 Municipal Gas Co..... Albany, N. Y.
 Alliance Gas Light Co..... Alliance, Ohio.
 New Gas Light Co..... Janesville, Wis.
 *Chicago Gas Light & Coke
 Co..... Chicago, Ill.
 *Joliet Gas Co..... Joliet, Ills.
 *Superior Light & Fuel Co. Superior, Wis.
 *Kewanee Gas Light Co... Kewanee, Ill.
 *Standard Gas Light Co... New York City.

* Building.

GUARANTEED ESTIMATES of Cost of Gas Furnished on Application.

GASHOLDER TANK CONSTRUCTION, ETC.

Gas Companies and others about to erect Gasholders will find it profitable to consult W. C. Whyte, who for over 30 years has made a specialty of

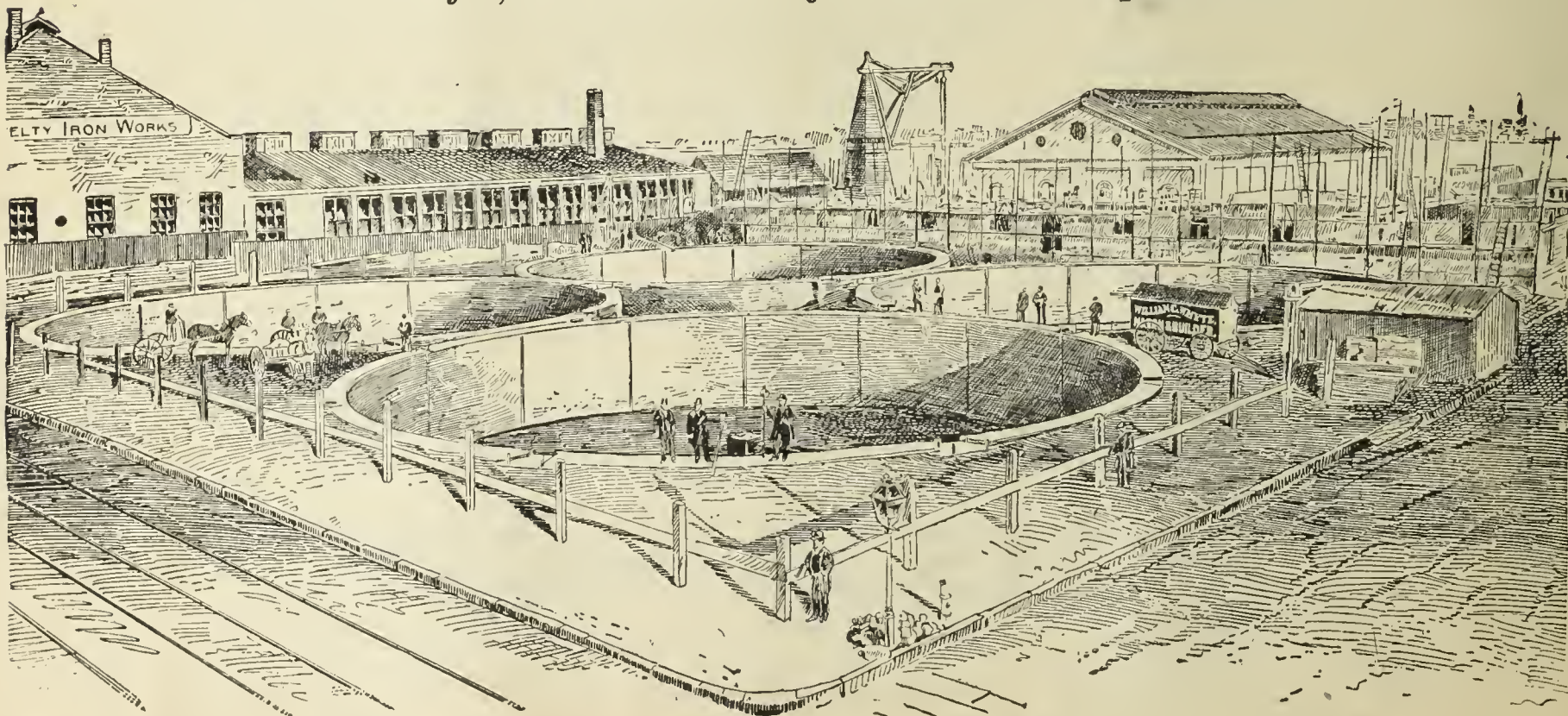

Tank Excavation and Mason Work.

Fifty Tanks now in operation show the sort of work done. Address

W. C. WHYTE, No. 15 Cortlandt Street, N. Y. City.

CONNELLY & CO.,

SOLE MANUFACTURERS OF THEIR PATENTED SPECIALTIES.

"IRON SPONGE." Saves money, saves labor, and is the most efficient purifying agent ever offered as a substitute for lime. Now used in every State in the Union, and purifying daily over thirty-five million cubic feet. Should be used in every gas works. Its own saving will pay for it many times over.

AUTOMATIC GOVERNOR. Has been on the market but three years, and in that time has been introduced more generally than any invention ever designed for use in gas works. Over two hundred of them now in use. Sensitive; reliable; perfectly automatic; reduces leakage; satisfies consumers, and gives great relief to the Manager. No gas works is complete without one of these machines.

STEAM JET EXHAUSTER. Designed particularly for small works. Combines Exhaust Tube, Steam Governor Gas Compensator, and Bye-Pass Valves in the most compact form possible; occupies but little space; uses very little steam; operated by ordinary workmen; saves formation of carbon in retorts; increases yield 10 to 15 per cent. Specially adapted for mixing air with oil gas. No works too small to use them profitably.

Prices given on all our specialties delivered at any point in the United States. Correspondence solicited.

CONNELLY & CO., No. 111 Broadway, New York City.

WILBRAHAM GAS EXHAUSTER

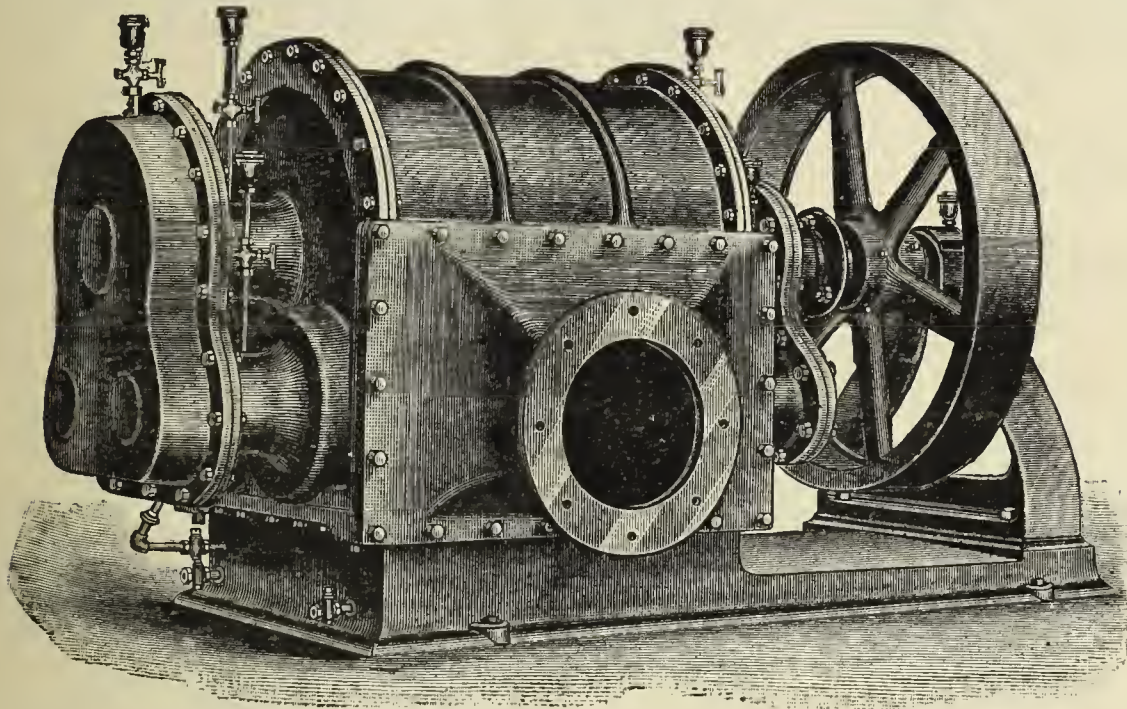

WILBRAHAM BROS.,
PHILADELPHIA, PA.

JARVIS ENGINEERING CO.,

61 Oliver St., Boston, Mass.

CONTRACTORS FOR ERECTING
COMPLETE STEAM OUTFITS FOR ELECTRIC LIGHTING STATIONS.

Steel Boilers set with Jarvis Pat. Boiler Setting

To burn **COKE SCREENINGS** for Fuel.

ARMINGTON & SIMS CO. ENGINES,

Belting direct to Dynamos, without using Shafting.

SEND FOR CIRCULARS.

REFERENCES.—Charlestown Gas & Electric Light Co., Charlestown, Mass.; Schenectady Gas & Electric Light Co., Schenectady N. Y.; Brookline Gas Co., Brookline, Mass.

Practical Electric Lighting

By A. BROMLEY HOLMES, A.M.I.C.E.

With 87 Illustrations. Third Edition. Price, \$1.00.

Electric Light Primer.

By CHARLES L. LEVEY.

A simple and comprehensive Digest of all the most important facts connected with the running of the Dynamo and Electric Lights, with Precautions for Safety, etc.

Price, 50 cents.

A. M. CALLENDER & CO., 42 Pine St., N.Y.

COMPOUND

Condensing or Non-Condensing.
16 SIZES, 5 to 500 H. P.

Not yet equaled by any form of Engine for
HIGH FUEL DUTY AND SIMPLICITY.

STANDARD

13 Sizes in Stock.
5 to 250 H. P.
3000 in use in all parts of the Civilized World.

JUNIOR

6 Sizes in Stock,
5 to 50 H. P.
An Automatic Engine cheaper than a Slide Valve.
WELL BUILT. ECONOMICAL. RELIABLE.

Over 300 Sold the First Year.

All the above built strictly to Gauge with
INTERCHANGEABLE PARTS.

REPAIRS CARRIED IN STOCK.

SEND FOR ILLUSTRATED CATALOGUES.

WESTINGHOUSE
ENGINES
The Westinghouse Machine Co.
PITTSBURGH, PA. U.S.A.

SELLING DEPARTMENT IN THE UNITED STATES.

New York,	47 Cortlandt St.	} Westinghouse, Church, Kerr & Co.
Boston,	Hathaway Building,	
Pittsburgh,	Westinghouse Build'g,	
Chicago,	156, 158 Lake St.	
Philadelphia,	608 Chestnut St. M. R. Muckle, Jr. & Co.	
St. Louis,	302, 304 Washington Av.	} Fairbanks & Co.
Kansas City,	312 Union Avenue,	
Denver,	1330 Seventeenth St.	
Omaha,	1619 Capitol Avenue, F. C. Ayer.	
Pine Bluffs, Ark.	Geo. M. Dille & Sons.	
Salt Lake City,	259 S. Main St.	} Utah & Montana Machinery Co.
Butte, Mont.	L. Granite St.	
San Francisco,	21, 23 Fremont Street, Parke & Lacy Co.	
Portland, Or.	33, 35 N. Front St. Parke & Lacy Mch. Co.	
Charlotte, N. C.	36 College St.	} The D. A. Tompkins Co.
Atlanta, Ga.	45 S. Prior St.	
Dallas, Tex.	Keating Imp. & Machine Co.	
Chattanooga, Tenn.,	C. R. James & Co.	



CHAPMAN VALVE MANUFACTURING CO.,

MANUFACTURERS OF

Valves and Gates for Gas, Ammonia, Water, Etc.

Also, Gate Fire Hydrants With and Without Independent Nozzle Valve. All Work Guaranteed.

WORKS & GEN'L OFFICE:
Indian Orchard, Mass.

TREASURER'S OFFICE:
72 Kilby & 112 Milk Sts, Boston, Mass.

LUDLOW VALVE MFG. CO.



OFFICE AND WORKS,

938 to 954 River Street and 67 to 83 Vail Av.,
TROY, N. Y.

Parson's Steam Blower,

FOR IMPROVING BAD DRAUGHT IN BOILERS, AND FOR BURNING BREEZE OR OTHER WASTE MATERIAL.

PARSON'S TAR BURNER,

FOR UTILIZING COAL TAR AS FUEL.

PARSON'S AIR JET TUBE CLEANER,

FOR CLEANING BOILER TUBES.

These devices are all first-class. They will be sent to any responsible party for trial. No sale unless satisfactory. Manufactured by the WATERTOWN STEAM BLOWER COMPANY.

H. E. PARSON, Supt., 33 & 35 Liberty St., N.Y.

MILLS' REVERSIBLE LIME TRAY,

AND

WOODWORK

Of Every Description

NEEDED BY GAS WORKS.

SEND FOR CIRCULAR AND PRICE LIST TO

BARTLETT, HAYWARD & CO.,

Pratt and Scott Streets, Baltimore, Md.

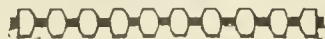
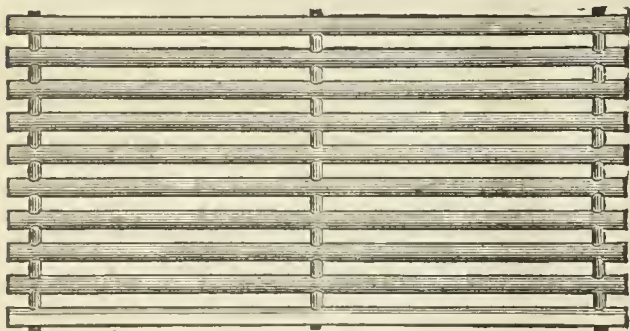

Hydraulic Main Dip Regulators, also Check Valves, Foot Valves, Yard-wash and Fire Hydrants. Send for Circulars.

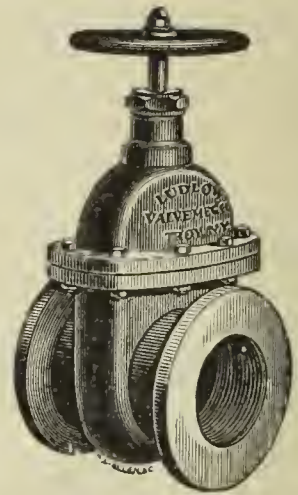

Valves.—Double and Single Gate, 1/2 in. to 48 in., outside and inside Screws. Indicator, etc., for Gas, Water, Steam, and Oil. Send for Circulars.

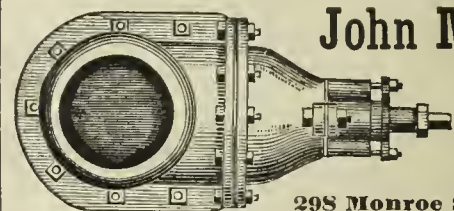

John McLean

Man'facturer

GAS VALVES.

298 Monroe Street, N. Y.

SPECIAL TRAYS FOR IRON SPONGE OR OXIDE OF IRON.

CHURCH'S TRAYS A SPECIALTY.

REVERSIBLE-STRONGEST-MOST DURABLE-MOST EASILY REPAIRED.



306-310 ELEVENTH AVENUE, NEW YORK.

WE ALSO MAKE THE CHEAPEST AND STRONGEST REVERSIBLE BOLTED TRAYS IN THE MARKET.

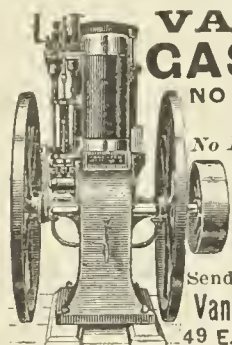

VAN DUZEN GAS ENGINE

NO BOILER. NO COAL. NO ENGINEER.

No Extra WATER RENT or INSURANCE.

INSTANTLY STARTED.

DURABLE, RELIABLE.

SAFE and ECONOMICAL.

Send for description and prices.

Van Duzen Gas Engine CO.,

49 E. 2nd St., CINCINNATI, O.

A. MacKinnon Machine Co., Agts., 22 Warren St., N.Y.

The Management of Small Gas Works.

BY C. J. R. HUMPHREYS.

Price, \$1.

Orders to be sent to **A. M. CALLENDER & CO.,**

42 PINE STREET, NEW YORK.

THE CLERK GAS ENGINE CO.,
Main Office, 1012, 1014, 1016, 1018 Filbert St., Philadelphia, Pa.

WM. W. GOODWIN, Prest.

E. STEIN, Sec.

S. LEWIS JONES, Asst. Sec.

A. J. DOTY, Supt.

The utility and convenience of the Gas Engine being no longer an open question, it only remains now for intending purchasers to select the BEST. We claim for the CLERK GAS ENGINE that it is equal to any other manufactured as regards steadiness in running, simplicity, and ease of keeping in repair, and that it gives the greatest amount of power for the least money (both in first cost and expense of running) of any engine made. In support of this claim we refer to the test of the Gas Engines made under the direction of the American Institute of New York, in December, 1885, and heretofore published in these columns. These engines are especially adapted for continuous running under heavy loads, and we can refer to Engines which have run 22 hours a day for months at a time

Made in Sizes of 5 10 15 20, and 25 Horse Power. All Engines Guaranteed for One Year.

GAS STOVES.

GAS METERS.

GAS STOVES.

THE AMERICAN METER CO.,

MANUFACTURERS OF

GAS METERS, Station Meters,

METER PROVERS, PHOTOMETERS,
PRESSURE GAUGES OF ALL KINDS,



Standard 3 Diaphragm Dry Meter

AND



Standard 2 Diaphragm Dry Meter.

Apparatus for Testing the Quantity and Quality of Gases.

GAS STOVES FOR HEATING AND COOKING

Sole Agents in the United States for

Verity's Patent Gas Fires.

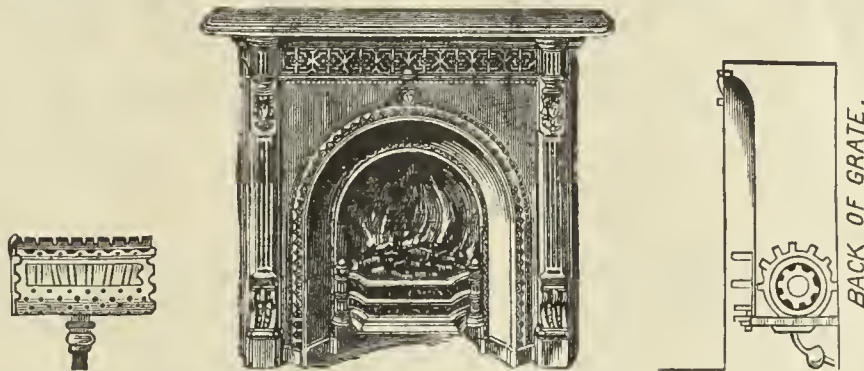

Circulars and Price Lists on Application.

MANUFACTORIES,

508 to 514 West Twenty-second St., N. Y.

Arch and Twenty-second St., Phila.

Nos. 244 & 246 North Wells Street, Chicago, Ill.

AGENCIES,

No. 177 Elm Street, Cincinnati, Ohio.

No. 222 Sutter Street, San Francisco, Cal

No. 810 North Second Street, St. Louis, Mo.

GAS STOVE SHOW ROOMS, No. 242 Sixth Avenue, New York City.

RETORTS AND FIRE BRICK.

J. H. GAUTIER & CO.,
CORNER OF
GREENE AND ESSEX STREETS,
JERSEY CITY, N. J.

MANUFACTURERS OF
**Clay Gas Retorts,
Gas House Tiles,
Fire Bricks, Etc. Etc.**
Ground Clay, Fire Brick and
Fire Sand in Barrels,

J. H. GAUTIER. C. E. GREGORY. C. E. GAUTIER.

BROOKLYN
Clay Retort & Fire Brick Works,
(EDWARD D. WHITE & CO.)
Manufacturers of Clay Retorts, Fire Brick,
Gas House and other Tile.
VAN DYKE, ELIZABETH, RICHARDS & PARTITION STS.
office, 88 Van Dyke St., Brooklyn, N. Y.

RETORTS AND FIRE BRICK.

LACLEDE FIRE BRICK MFG. CO.,
MANUFACTURERS OF
Fire Brick, Gas Retorts,

AND
ST. LOUIS STANDARD SEWER PIPE.
Blast Furnace and Cupola Linings, every description of Fire
Clay Material, Fire Clay Flue Linings, Chimney Tops
Dry Milled and Crude Fire Clays, etc.

OFFICE AND DEPOT
901, 903, and 905 Pine Street,
ST. LOUIS, MO.

ESTABLISHED IN 1845.

B. KREISCHER & SONS,

OFFICE FOOT OF HOUSTON ST., E. R., N. Y.

Gas Retorts,

TILES, FIRE BRICK.

AND EVERYTHING IN THE FIRE CLAY LINE.

RETORTS AND FIRE BRICK.

MANHATTAN
FIRE BRICK & ENAMELLED CLAY
RETORT WORKS
ADAM WEBER.

CLAY GAS RETORTS
AND RETORT SETTINGS
FIRE BRICKS, TILES, ETC.,
Office and Works, 15th Street and Avenue C., N. Y.

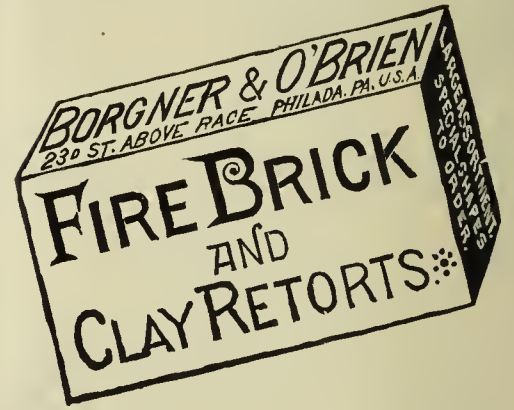

Works,
LOCKPORT STATION, PA.

—ESTABLISHED 1864.—

JAMES GARDNER, JR.,

Office, Rooms 19 & 20, Lewis Block,
PITTSBURGH, PA, P. O. Box 373.

Successor to WILLIAM GARDNER & SON.

Fire Clay Goods for Gas Works.

CHAS. H. SPRAGUE & SON, No. 70 KILBY STREET, BOSTON, MASS., Agents for the New England States.

GEO. C. HICKS, CHICAGO CHAS. A. REED,
Prest. Sec. & Treas.
Retort and Fire Brick Co.,
MANUFACTURERS OF
Fire Clay Goods of all Kinds,
AND BEST QUALITY ONLY.
Regenerative Furnaces & Water Gas Goods.
45th St., Clark to La Salle, Chicago.

GEROULD'S IMPROVED RETORT CEMENT.
A Cement for patching retorts, putting on mouthpieces, and
making up all bench-work joints. This Cement is mixed ready
or use. Economic and thorough in its work. Fully warranted
o stick. For recommendations and price list address
C. L. GEROULD & CO.,
5 & 7 Skillman St., Brooklyn, N. Y.
Western Agent, H. T. GEROULD, Mendota, Ill.

Parker-Russell
Mining and Mfg. Co.,

CITY OFFICE: { Me. mod-Jaccard Bldg., Rooms 307 & 308,
{ Broadway and Locust Street, St. Louis, Mo.

PROPRIETORS OF THE

OAKHILL GAS RETORT & FIRE BRICK W'KS

Our immense establishment is now employed almost entirely in
the manufacture of materials for

GAS COMPANIES.

We have studied and perfected three important points. Our re-
torts are made to stand changes of temperature, the strongest
heats of the furnace, and the abrasion of feeding and emptying.

We furnish and build Half-Depth or Full
REGENERATOR FURNACES
of different kinds and most approved styles.

Correspondence solicited.

THOS. SMITH, Prest. AUGUST LAMBLA, Vice-Prest. & Supt.

BALTIMORE
RETORT & FIRE BRICK CO.

MANUFACTORY AT

LOCUST POINT, BALTIMORE, MD.

Clay Retorts, Blocks & Tiles,
FIRE BRICK, FIRE CLAY,
AND FIRE CEMENT.

Red and Buff Ornamental Tiles and Chim-
ney Tops. Drain and Sewer Pipe (from
2 to 30 inches). Baker Oven Tiles
12 x 12 x 2 and 10 x 10 x 2.

WALDO BROS., 88 WATER ST., BOSTON, MASS
Sole Agents the New England States.

1889 DIRECTORY 1889

OF THE GAS LIGHT COMPANIES of the UNITED STATES & CANADA.

Price, \$8.00.

A. M. CALLENDER & CO., No. 42 Pine Street, N. Y. City.

HENRY MAURER & SON,

(ESTABLISHED 1836.)

EXCELSIOR FIRE BRICK & CLAY RETORT WORKS

WORKS, Perth Amboy, N. J.
OFFICE, 418 to 422 East 23d St., N. Y.

Clay Gas Retorts,
BENCH SETTINGS,
Fire Brick, Tiles, Etc.

FLEMMING'S Generator-Gas Furnace

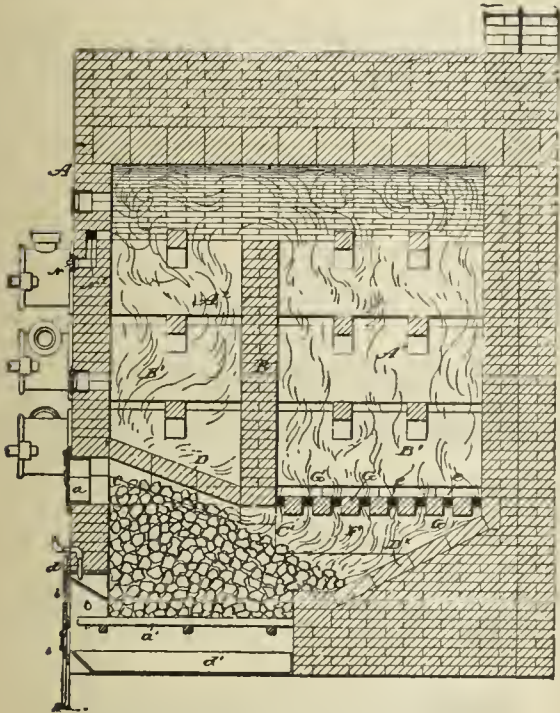

Materials furnished and Benches erected by

J. H. GAUTIER & CO., - Jersey City, N. J.

Address as above, or D. D. FLEMMING, Jersey City, N. J.

FRED. BREDEL,

CONTRACTOR FOR THE COMPLETE

Erection and Equipment of Gas Works.

SOLE PROPRIETOR OF THE

KLOENNE PATENTS

FOR NORTH AMERICA.

REGENERATIVE FURNACES.

(900 Retorts are now fired in America by the Kloenne-Bredel System.)

SELF-SEALING MOUTHPIECES.

(Over 800 Now in Use.)

Standard Condensers. Washer-Scrubbers.

TAR WASHERS FOR WATER GAS PLANTS.

(In use in the works of the Chicago Gas Lt. Co.)

GASHOLDERS.

Bredel's Automatic Gas Governor.

Refers, by permission, to Mr. Eugene Vanderpool, Newark, N. J.; Mr. E. G. Cowdery, Milwaukee, Wis.; and Mr. Theo. Forstall, Chicago, Ill. For further information, address

FRED. BREDEL,

No. 208 East Seventeenth Street, N. Y. City.

HENRY PRATT & CO.,

BUILDERS OF THE

PRATT & RYAN WATER GAS GENERATORS,

Arranged to Use Either Crude Oil or Naphtha.

Condensers, Scrubbers, Purifiers, and all Apparatus for Coal or Water Gas.

IRON ROOFS, BOILERS, TANKS, ETC.

Orders and Correspondence Solicited.

Plans and Estimates Furnished for New Works or for the Alteration of Old Works.

Office and Works, 869 to 875 So. Halsted St. CHICAGO, ILL.

THE BRENNER SELF-SEALING RETORT DOOR.

Simple, Strong, and Durable.

CLOSES ABSOLUTELY TIGHT & IS LOCKED BY A CAM LEVER. ALL NECESSARY ADJUSTMENT FOR WEAR PROVIDED.

BUILT BY

SMITH & SAYRE MFG. CO.,

No. 245 Broadway, - - - New York City.

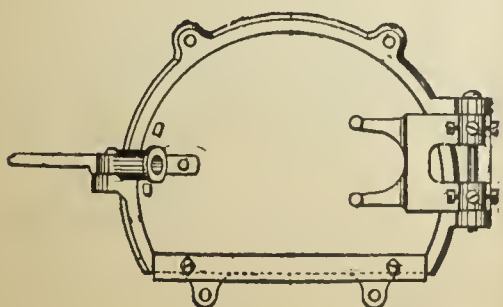

Brenner Self-Sealing Retort Door.

WILLIAM B. LUNDIE, Superintendent of the 42d Street Station of the Consolidated Gas Company, of New York, writes, under date of Jan. 4, 1889:

"We have 320 Brenner Self-Sealing Lids in use at this Station, built by the Smith & Sayre Mfg. Co. They require very little attention, and are the best of the kind that I have seen, giving entire satisfaction."

GAS AND WATER PIPES.

GAS AND WATER PIPES.

ENGINEERS.

SAM'L R. SHIPLEY, Pres.
HENRY B. CHEW, TreJAS. P. MICHELLON, Sec.
WM. SEXTON, Supt.P. D. WANNER, Chairman. A. H. MELLERT, Mangr. of Wk
R. B. KINSEY, Secretary. F. A. KNOPP, Treasurer.**GLOUCESTER IRON WORKS,**
GLOUCESTER CITY, N. J.**Cast Iron Gas & Water Pipes, Stop Valves, Fire Hydrants, Gasholders. &c.**

Office, Rooms 61 and 63 Bullitt Building, 131 S. 4th St., Phila., Pa.

WARREN FOUNDRY AND MACHINE CO.,

Established 1856.

Works at Phillipsburgh, N. J.

New York Office, 160 Broadway.

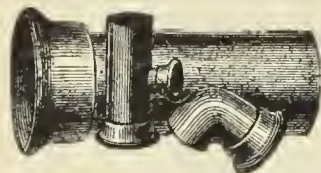
**CAST IRON WATER AND GAS PIPE,**

FROM TWO TO FORTY-EIGHT INCHES DIAMETER. ALSO, ALL SIZES OF

Flange Pipe for Sugar House and Mine Work. Branches, Bends, Retorts, etc., etc.

DENNIS LONG & COMPANY,

LOUISVILLE, KY.,



Manufacture Exclusively

CAST IRON GAS & WATER PIPE & SPECIAL CASTINGS
OF ALL SIZES.**King's Treatise on Coal Gas.**

A standard text-book for the Engineers and Managers of Gas Works, and for all who are concerned or take an interest in the manufacture and distribution of Coal Gas, and in the utilization of the Secondary Products resulting therefrom; treating also of the Gas Engine, and of Gas Cooking and Heating Appliances.

In 3 Vols. Price per Vol., \$10. Sold either by Volume or in Sets.

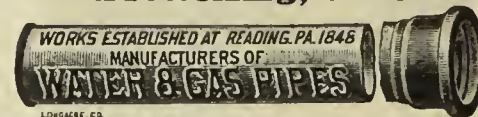
A M. CALLENDER & CO., 42 Pine St., N. Y.**MELLERT FOUNDRY & MACHINE CO. Ltd.**
and **READING FOUNDRY CO., Ltd.,**
Reading, Pa.Specials—Flange Pipe, Valves and Hydrants
Lamp Posts, Retorts, etc.

General Foundry and Machine Work.

JOHN FOX, Selling Agent. 160 Broadway, N.Y.**THE OHIO PIPE COMPANY,**

MANUFACTURERS OF

Cast Iron Gas & Water Pipe,

BRANCH AND SPECIAL CASTINGS.

Gas-House Bench Castings, Hydraulics, Lamp Posts, Flange Pipe
and Specials, Architectural Castings, Building Columns,
Joists, Cellar Grates, Sash Weights, etc.

GENERAL FOUNDERS AND MACHINISTS.

Columbus, Ohio.

M. J. DRUMMOND,

SPECIAL CASTINGS AND LAMP POSTS.

Office, Corbin Building, 192 Broadway, N. Y.

EMAUS PIPE FOUNDRY.

DONALDSON IRON COMPANY. EMAUS, PA.



MANUFACTURERS OF

CAST IRON PIPE AND SPECIAL CASTINGS
FOR WATER AND GAS.**JOS. R. THOMAS,**

No. 42 Pine Street, N.Y. City.

CONSULTING AND CONSTRUCTING

Gas Engineer and Contractor.PLANS, SPECIFICATIONS, AND ESTIMATES
FURNISHED.**Contracts taken for all Appliances**
required at a **Gas Works,**

Either for New Works or Extensions to Old Plants.

WM. MOONEY

(Successor to WM. FARMER)

No. 94 Liberty St., N. Y. City.

GAS ENGINEER AND CONTRACTOR FOR THE ERECTION
OF GAS WORKS, OR APPARATUS OF ANY
CAPACITY.

Plans and Specifications Furnished.

WM. GARDNER,
Gas Engineer,

Lewis Block, Room 20, Pittsburgh, Pa.

Those who intend to make alterations in existing gas plants, or
who contemplate the erection of new works, will find it to their
interest to open correspondence with the above. Plans made
and estimates furnished.

BARTLETT, HAYWARD & CO.

Baltimore, Md.

Triple Double, & Single-Lift
GASHOLDERS.

Iron Holder Tanks.

ROOF FRAMES.

Cirders.

BEAMS.

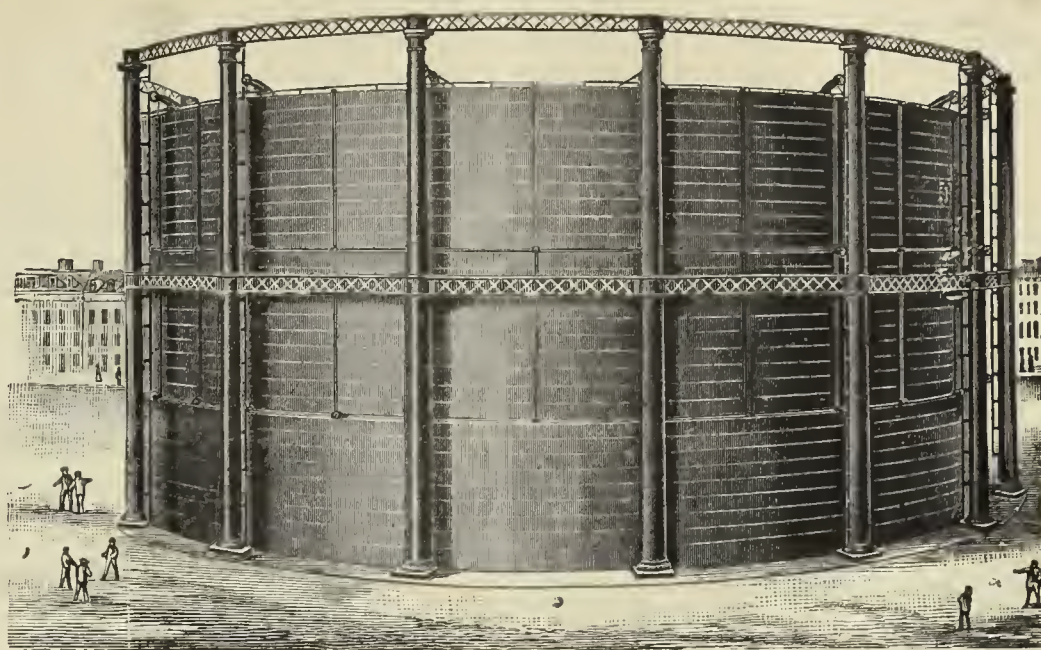

PURIFIERS.

CONDENSERS.

Scrubbers.

BENCH CASTINGS.

OIL STORAGE TANKS.

Boilers.

The Wilkinson Water Gas Process.

THIRTY-CANDLE, NON-CONDENSABLE, FIXED GAS. THE MOST SUCCESSFUL GAS PROCESS IN OPERATION.

Munich Regenerative Furnace, System Drs. Schilling & Bunte.

HAZELTON BOILERS.

Gas Works Designed and Constructed.

Pascal Iron Works. ESTABLISHED 1821. Delaware Iron Works.

MORRIS, TASKER & CO.,

INCORPORATED.

OFFICE, 224 SOUTH THIRD STREET, - - PHILADELPHIA, PA.

CONTRACTORS, BUILDERS, AND MANUFACTURERS OF

Gas, Water & Sugar Works

Bench Castings.

Condensers.

Scrubbers.

Purifiers.

Hyd. Carriages.

Iron Floors,

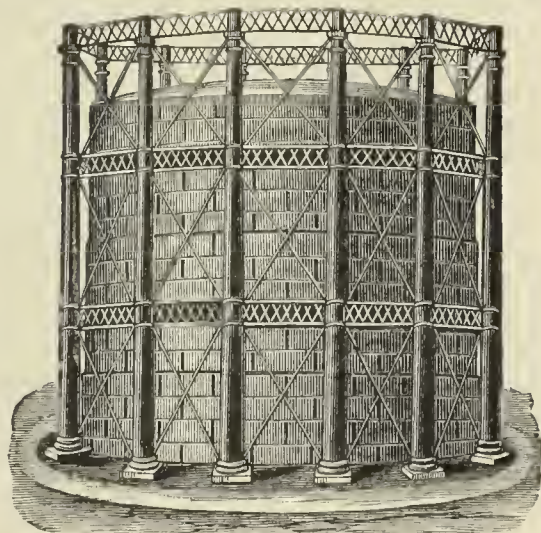

Iron Roofs.

Street Stops,

Valves, etc.

Stand-Pipes.

Water & Oil

Tanks, all Sizes.

Single, Double, and Triple-Lift Gas Holders.

SELF-SEALING RETORT LIDS. STAMPED STEEL RETORT LIDS.

Locomotive Water Columns, Filters, etc. Boiler Tubes, Wrought Iron Pipe & Fittings

Plans, Specifications and Estimates for all kinds of Machinery furnished on application.

Foundries & Works,
MILLVILLE, FLORENCE,
and CAMDEN, N. J.

R. D. WOOD & CO.,

Engineers,
Iron Founders,
and
Machinists.

400 Chestnut St., PHILADELPHIA, PA.

MANUFACTURERS OF

CAST IRON PIPE,

Gas Holders,

SINGLE, DOUBLE, AND TRIPLE LIFTS, WITH
OR WITHOUT WROUGHT IRON
OR STEEL TANKS.

PURIFIERS, CONDENSERS.

Scrubbers.

BENCH WORK.

Iron Floors and Roofs, Plate Girders.

Heavy Loam Castings.

HYDRAULIC WORK.

Lamp Posts, Valves, Etc.

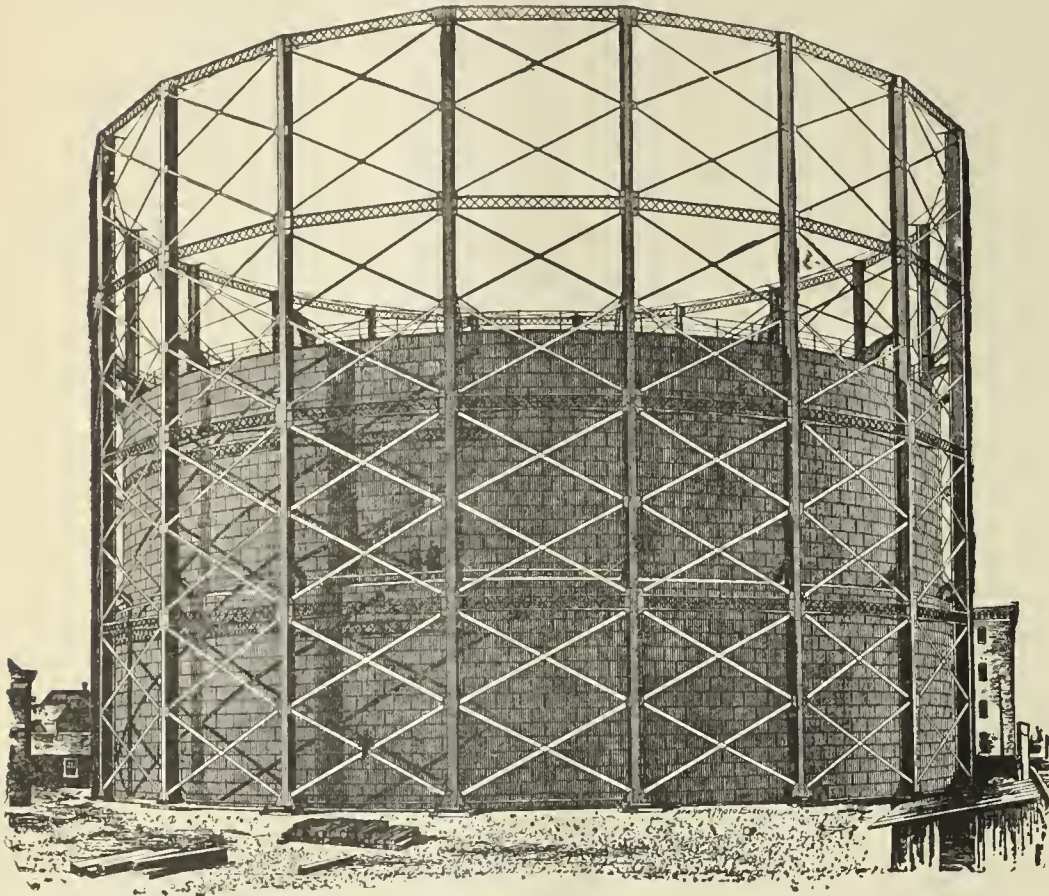

ROOTS' NEW GAS EXHAUSTER.

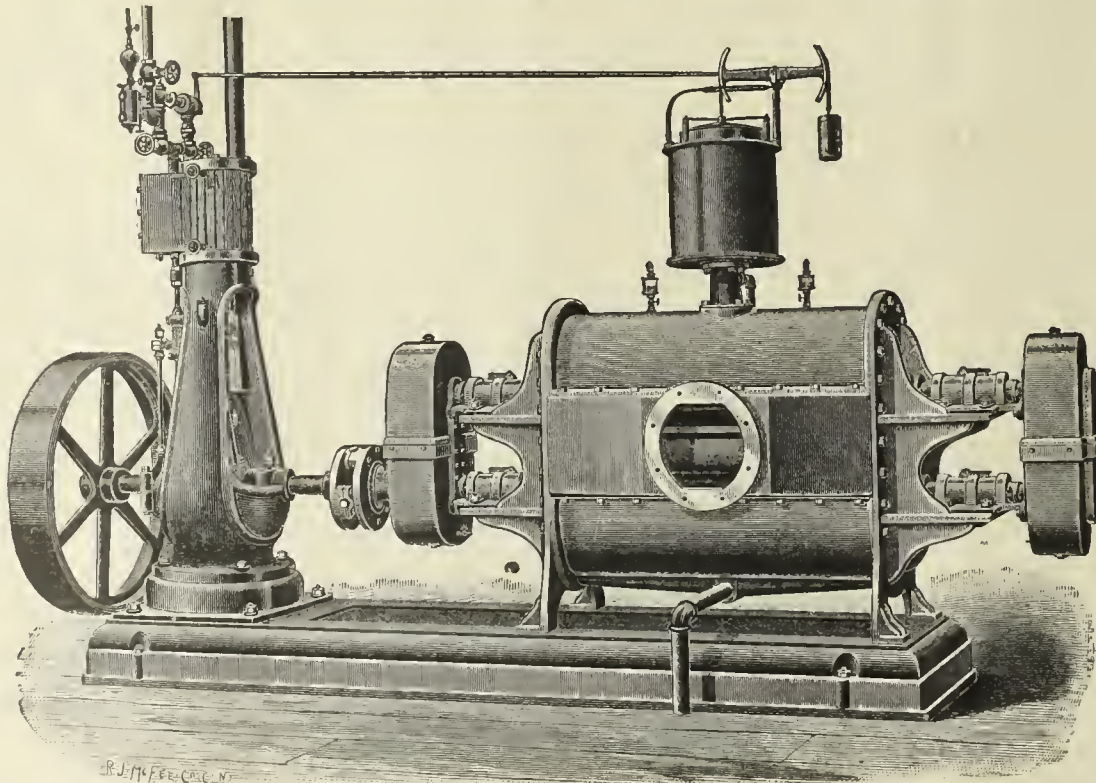

CONSTRUCTED ON ENTIRELY NEW PRINCIPLES.

THE ONLY EXHAUSTER MADE WHERE

The Parts Needing Attention are External and Easily Accessible.

Send for Descriptive Catalogue and Price List.

P. H. & F. M. ROOTS, Patentees and Manufacturers, CONNERSVILLE, IND.

S. S. TOWNSEND, Gen. Agt., 22 Cortlandt St., N. Y.

COOKE & CO., Selling Agts., 22 Cortlandt St., N. Y.

GAS WORKS APPARATUS AND CONSTRUCTION.

GAS WORKS APPARATUS AND CONSTRUCTION.

JAMES R. FLOYD & SONS,

(SUCCESSORS TO HERRING & FLOYD)

Oregon Iron Works,

W. 20th & 21st. Sts., bet. 10th & 11th Aves.,

NEW YORK CITY.

Engineers and Contractors

FOR THE

CONSTRUCTION OF GAS WORKS.

MANUFACTURERS OF

All Kinds of Castings and General Ironwork

FOR

GAS APPARATUS.

Bench Castings, Regenerative and Half Regenerative Furnace Castings.

Condensers, Scrubbers, Purifiers, Street Drips and Connections,

Valves,

Hydraulic Hoisting Purifier Carriage, Self-Sealing Retort Lids, Improved Valve Stand and Indicator, Seller's Cement.

Plans, Specifications, and Estimates furnished for Construction of New or Alteration of Old Works.

CONTINENTAL IRON WORKS.

THOS. F. ROWLAND, Prest.

WARREN E. HILL and CHAS. H. CORBETT, V-Prests.

THOS. F. ROWLAND, JR., Sec. & Tr.

P. O. Station G., BROOKLYN, N. Y.

ENGINEERS AND MANUFACTURERS OF

Gas Holders

CONDENSERS, SCRUBBERS, VALVES,

PURIFIERS, SELF-SEALING RETORT LIDS

Hydraulic Mains,

And all other articles connected with the manufacture and distribution of Gas.

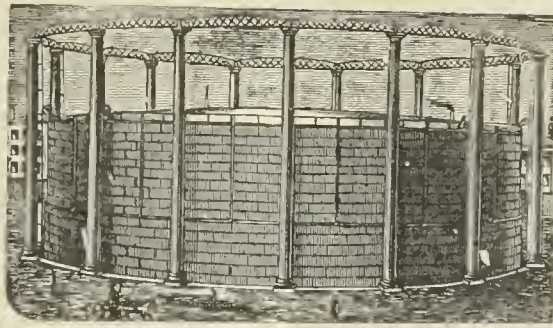

H. RANSHAW, Prest. & Mangr.

WM. STACEY, Vice-Prest.

T. H. BIRCH, Asst. Mangr.

R. J. TARVIN, Sec. & Treas.

STACEY MFG. CO.,

MANUFACTURERS OF

Single and Telescopic Gasholders,

IRON ROOFS, BRIDGES, LAMP POSTS,

Water and Oil Tanks, Coal Elevator Cars,

COKE CRUSHERS, BENCH CASTINGS,

And all kinds of Wrought and Cast Iron Work used in the erection of Coal and Oil Gas Works Rolling Mill Machinery and Heavy Castings a Specialty.

Foundry:

33, 35, 37 & 39 Mill Street.

Wrought Iron Works:

16, 18, 20, 22, 24 & 26 Ramsey Street.

Cincinnati, Ohio.

Bouton Foundry Co.,

FOUNDERS AND MACHINISTS,

CHICAGO, ILL.

Gas Works Apparatus,

PURIFIERS, CONDENSERS,

Bench Work

SPECIALS, LAMP POSTS,

SCRUBBERS,

Iron Roofs and Floors.

Plans and Estimates furnished for new works or extensions of old works.

1842. **DEILY & FOWLER,** 1889.

Laurel Iron Works.

Address, No. 39 Laurel Street, Philadelphia, Pa.

BUILDERS OF

GASHOLDERS,

Single and Telescopic.

HOLDERS BUILT 1884 TO 1888, INCLUSIVE:

- | | | | | |
|----------------------------|-----------------------------|---------------------------|--------------------------|------------------------|
| Newport, R. I. | Long Island City, N. Y. | Port Chester, N. Y. | Malden, Mass. | West Chester, Pa. (3d) |
| Portland, Oregon. | Macon, Ga. | New Rochelle, N. Y. | Paducah, Ky. | Lancaster, Pa. (3d) |
| Allegheny, Pa. (2d.) | York, Pa. | Salem, N. J. (3d) | Norwich, Conn. | Fac ny, Pa. (two) |
| Atlanta, Ga. (2d.) | Chester, Pa. | Omaha, Neb. (2d) | Seattle, W. T. | Mount Vernon, N. Y. |
| N.Y. City (Central Gas Co) | Hazleton, Pa. (2d.) | Lynn, Mass. (2d) | San Diego, Cal. | Binghamton, N. Y. |
| Lynchburg, Va. (2d.) | State Island, N. Y. | Little Rock, Ark. | Northern Gas Lt. Co., of | Concord, N. H. |
| Saylesville, R. I. | Clinton, Mass. (Lan. Mills) | Irrington, N. Y. | New York N. Y. | Dover, Del. (2d) |
| Rondout, N. Y. | Saugerties, N. Y. | South Boston, Mass. | Westerly, R. I. | Calais, Me. |
| Atlantic City, N. J. | Clinton, Mass. (Lan. Mills) | Rye, N. Y. (2) | Willimantic, Conn | New London, Conn. (2d) |
| Augusta, Ga. | Chattanooga, Tenn. | Woodstock, Ont. | Montclair, N. J. | West Chester, N. Y. |
| Waltham, Mass. (2) | Galveston, Texas. (3d.) | Malden, Mass. | Attleboro, Mass. | Bay Shore, L. I. |
| Mahanoy City, Pa. | Omaha, Neb. | Staten Island, N. Y. (2d) | Santa Cruz, Cal. | Washington, D. C. |
| New Castle, Pa. | Fort Plain, N. Y. | Woodstock, Ont. | Eric, Pa. (2d) | |
| | Brunswick, Ga. | | | |

SMITH & SAYRE MFG. COMPANY,

G. G. PORTER, Prest.

245 Broadway, N. Y.

CHAS. W. ISBELL, Sec'y.

Machinery & Apparatus for Gas Works

Drawings, Plans, and Estimates Furnished for the Improvement, Extension, or Alteration of Gas Works, or for the Construction of New Works.

Mackenzie's Patent Rotary and Steam Jet Gas Exhausters, Governors, Compensators, Condensers, Washers, Scrubbers. Isbell's Patent Automatic Street Pressure Governor, Gas and Water Valves, Hydraulic Main Dip Regulator, Bench Castings, etc. Purifying Boxes and "Standard" Scrubbers, Isbell's Patent Self-Sealing Retort Doors,

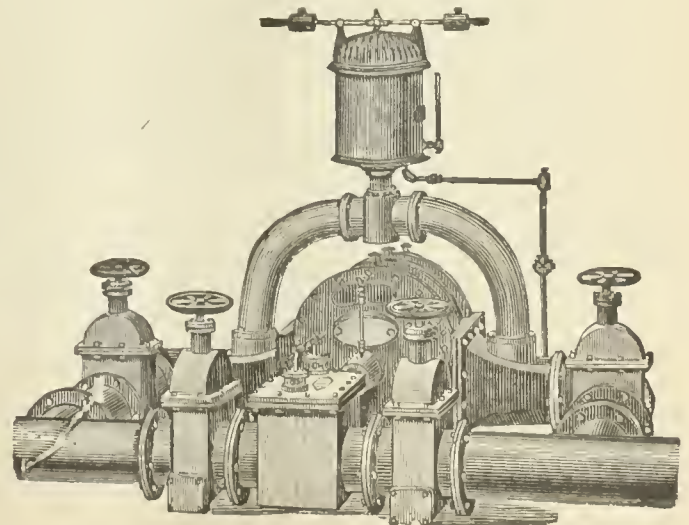

GAS COALS.

CANNEL COALS.

GAS ENRICHERS.

JAMES D. PERKINS. **PERKINS & CO.,** F. SEAVERN.
228 & 229 Produce Exchange, New York.

Cable Address, "PERKINS, NEW YORK."

Post Office Box 3695, New York.

GENERAL SALES AGENTS FOR

The Youghiogeny River Coal Company's

OCEAN MINE YOUGHIOGHENY GAS COAL.

HON. W. L. SCOTT, Prest.

M. H. TAYLOR, Vice-Prest.

This Colliery is located at SCOTT HAVEN, PA., in the center of the Youghiogeny Gas Coal District, and produces the ONLY RELIABLE YOUGHIOGHENY COAL for gas purposes. (See Map on p. 87 of this JOURNAL, Feb. 16, '85.)

POINTS OF SHIPMENT,

Locust Point, BALTIMORE.

Pier No. 62, PHILADELPHIA.

Also, SOLE AGENTS for the

BRECKENRIDGE CANNEL,

OF KENTUCKY.

Within the past two years we have delivered this Cannel to over ONE HUNDRED COMPANIES IN THIRTY-THREE DIFFERENT STATES, and it is now in use in some of the large Gas Works

On the Continent and in South America,

where it successfully competes with the Australian Shale. It is the ONLY AMERICAN GAS CANNEL of sufficiently high grade to warrant EXPORTATION TO EUROPE AND SOUTH AMERICA, and it is the only economical substitute for OIL OR NAPHTHA. ONE GROSS TON will produce

10,000 Cubic Feet of 75 Candle Gas,	} equal to {	750,000 Candle Feet of Gas, and 26 Bushels of merchantable Coke weighing 900 Pounds
or 12,500 " " 60 " "		
or 15,000 " " 50 " "		

This is the ONLY GAS CANNEL that will produce a REALLY MERCHANTABLE COKE. It can be delivered in parcels of one carload or more to any point in the United States or Canada. Cargo shipments of any size required can be made from NEW YORK, PHILADELPHIA, BALTIMORE, or NEWPORT NEWS. Samples will be sent and particulars of price, etc., forwarded upon application to above address.

JAMES & WILLIAM WOOD,

Gas and Cannel Coal Contractors,

No. 40 St. Enoch Sq., Glasgow. No. 2 Talbot Court, London.

Proprietors of the BATHVILLE COLLIERIES (which produce the celebrated BOGHEAD CANNEL), Shields, Shieldmuir, Drumpeller, and other Collieries. This Firm offer

STANDARD CANNELS,

Unequaled as Gas Enrichers.

Also, WEST FAIRMONT GAS COAL, of W. Va.

Analyses, prices, and all further information furnished on application to

Agency for U. S., Room 93, Nos. 2 & 4 Stone St., N.Y. City.

The Standard Oil Company,

REFINERS OF

NAPHTHA AND GASOLINES.

ALSO MANUFACTURERS OF

A Special Grade of Naptha for Gas Companies

FOR ENRICHING COAL GAS.

Correspondence solicited.

No. 43 Euclid Avenue, Cleveland, Ohio.

To Gas Companies.

We make to order CAP BURNERS to burn any amount under a stated pressure. Send for samples.

Also, SERVICE CLEANERS, DRIP PUMPS, and STREET MAIN PROVING APPARATUS.

C. A. GEFROER,

248 N 8th Street, Phila., Pa.

COKE CRUSHERS.

GAS COALS.

GAS COALS.

Newburgh Orrel Coal and Coke Co.

MINERS AND SHIPPERS OF

STEAM, SMITHING, AND GAS COALS,
Foundry and Crushed Coke.

Home Office, 33 S. Gay Street, Baltimore, Md.

CHAS. MACKALL, Gen. Mangr.
CHAS. W. HAYS, Agent, No. 1 Broadway, N. Y.
Shipping Wharves, Locust Point, Baltimore.

The Despard Gas Coal Co.,

MINERS AND SHIPPERS OF

DESPARD GAS COAL,

AND MANUFACTURERS OF

COKE.

MINES, Clarksburg, Harrison Co., W. Va.

WHARVES, Locust Point, Baltimore, Md.

OFFICE, 225 E. German St., " "

ROUSSEL & HICKS, } AGENTS. } BANGS & HORTON,
71 Broadway, N. Y. } 60 Congress St., Boston.

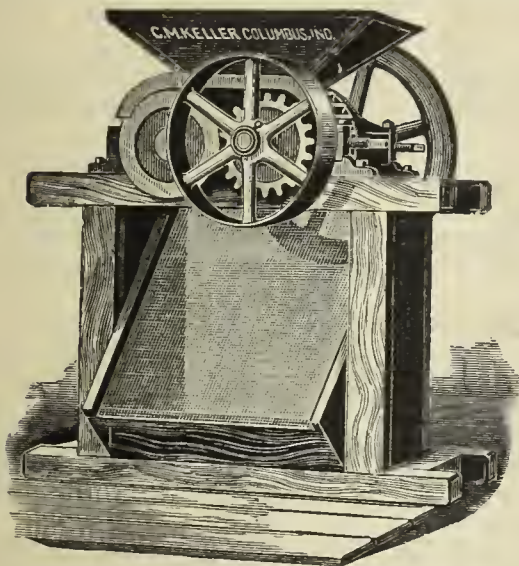

Keller's Adjustable Coke Crusher.

SIMPLE, STRONG, AND DURABLE.

C. M. Keller, Sec. & Supt. Gas Lt. & Coke Co. Columbus, Ind.

Correspondence Solicited.

King's Treatise on Coal Gas.

The most complete work on Coal Gas ever published

Three Vols. Bound, \$30.

THE
PENN GAS COAL CO.
OFFER THEIR
Coal, Carefully Screened & Prepared for Gas Purposes.

Their Property is located in the Youghiogheny Coal Basin, near Irwin and Penn Stations on the Pennsylvania Railroad, and on the Youghiogheny River.

Principal Office:

209 SOUTH THIRD STREET, PHILA., PA.

Points of Shipment:

Pennsylvania Railroad Piers; Greenwich Wharves, Delaware River; Pier No. 1 (Lower Side), South Amboy, N. J.

Chesapeake & Ohio Railway Coal Agency,

FOR THE SALE OF THE

Superior Kanawha Gas Coals, Cannelton Cannel,
Also, SPLINT AND STEAM COALS.

From the Kanawha and New River Regions, on the line of the Chesapeake & Ohio R'way.

C. B. ORCUTT, General Agent, - - No. 1 Broadway (Room 217) New York City.

FRANCIS H. JACKSON, Prest. EDMUND H. MCCULLOUGH, V.-Prest. CHAS. F. GODSHALL, Treas. H. C. ADAMS, Sec.

THE WESTMORELAND COAL CO.

Chartered 1854.

Mines situated on the Pennsylvania and the Baltimore and Ohio Railroads, in Westmoreland County, Penn.

POINTS OF SHIPMENT:

PHILADELPHIA, BALTIMORE, SOUTH AMBOY, N. J.,
WATKINS (SENECA LAKE), N. Y.

Since the commencement of operations by this Company its well-known Coal has been largely used by the Gas Companies of New England and the Middle States, and its character is established as having no superior in gas-giving qualities, and in freedom from sulphur and other impurities.

Principal Office, 224 South 3d St., Phila., Pa.

WM. HENRY WHITE,

No. 32 Pine Street, - - - New York City.

ENGINEER AND CONTRACTOR FOR THE

Erection and Extension of Gas, Water, and Electric Light Works.

SOLE REPRESENTATIVE OF THE

McILHENNY REGENERATOR FURNACE PATENTS

And the Martin Water Gas Process.

Edison Incandescent and American Arc Electric Light Plants Installed.

Correspondence with Gas Companies contemplating extending or improving their Plants respectfully invited.
Plans and Estimates Furnished.

GAS METERS.

GAS METERS.

GAS METERS.

JOHN J. GRIFFIN & CO.,

Gas Meter Manufacturers,

Philadelphia, New York
and Chicago,

Will Occupy this Space Hereafter.

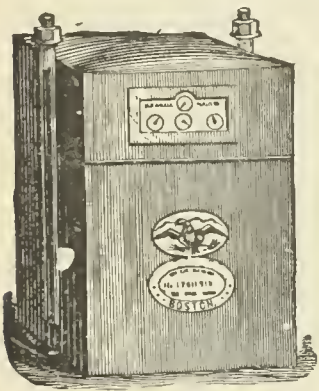

Dry Gas Meters.

With 40 years' experience and the best facilities for manufacturing, is enabled to furnish reliable work and answer orders promptly.

NATHANIEL TUFTS,

No. 153 Franklin Street, Boston, Mass.,

MANUFACTURER OF

DRY GAS METERS.

Station Meters of any Capacity.

Test and Experimental Meters, Pressure Registers, Pressure Gauges,
Pressure and Vacuum Gauges.

METER PROVERS, PHOTOMETERS, STREET LANTERNS, ETC., ETC.

Patent Cluster Lanterns for Street Illumination.

250 & 252
Pearl Street,

JOHN HILLEN'S BROOKLYN GAS METER WORKS.

BROOKLYN,
N. Y.

MANUFACTURER OF

IMPROVED GAS METERS

REPAIRING OF METERS (of all makers) a specialty. All defective working parts are replaced without extra charge. A guarantee is given with all work sent from this shop. Write for Price List.

SCIENTIFIC BOOKS.

We are prepared to furnish to Gas Managers, and others interested in the topics treated of, the following books, at prices named:

KING'S TREATISE ON THE MANUFACTURE OF COAL GAS. Three vols.: \$10 per vol.	GAS WORKS—THEIR ARRANGEMENT, CONSTRUCTION, PLANT, AND MACHINERY. \$8.	DISTILLATION OF COAL TAR AND AMMONIACAL LIQUOR by GEO. LUNGE. New Edition. \$12.50.
GAS MANUFACTURE, by WILLIAM RICHARDS. 4to., with numerous Engravings and Plates, in Cloth binding. \$12.	COAL: ITS HISTORY AND USE, by PROF. THORPE. \$3.50.	A TREATISE ON THE COMPARATIVE COMMERCIAL VALUES OF GAS COALS AND CANNELS, by D. A. GRAHAM 8vo., Cloth. \$3.
TECHNICAL GAS ANALYSIS. \$2.80.	THE GAS WORKS OF LONDON, by COLBURN. 60 cents.	GAS COMPANIES DIRECTORY. \$3.
GAS CONSUMER'S GUIDE. \$1.	THE GAS FITTER'S GUIDE, Showing the Principles and Practice of Lighting with Coal Gas, by JOHN ELDREDGE. 40 cents.	GAS VERSUS ELECTRIC LIGHT. 50 cents.
A GUIDE TO GAS LIGHTING. 40 cents.	GAS WORKS, AND MANUFACTURING COAL GAS, HUGHES. \$2.20.	THE AMERICAN GAS ENGINEER AND SUPERINTENDENT'S HANDBOOK, by WM. MOONEY. \$3.
GAS MEASUREMENT AND GAS METER TESTING, by F. W. HARTLEY. \$1.60	THE MANAGEMENT OF SMALL GAS WORKS, by C. J. R. HUMPHREYS. \$1.	GAS ENGINE INDICATOR DIAGRAM, by W. E. AYRTON. Paper. 20 cents.
GAS CONSUMER'S HANDBOOK, by WILLIAM RICHARDS, C.E.; 18mo., Sewed. 20 cents.	MANUAL FOR GAS ENGINEERING STUDENTS, by D. LEE, 40 cents.	ILLUMINATING AND HEATING GAS, by W. BURNS. \$1.50.
A PRACTICAL TREATISE ON GAS AND VENTILATION with Special Relation to Illuminating, Heating, and Cooking Gas, by E. E. PERKINS. \$1.25.	HOW TO MANAGE GAS, by F. WILKINS. Paper. 20 cents.	TESTING PIPES AND PIPE JOINTS, by M. M. PATERSON. 80 cents.
PRACTICAL TREATISE ON HEAT, by THOMAS BOX. Second edition. \$5.	THE DOMESTIC USES OF COAL GAS, AS APPLIED TO LIGHTING, by W. SUGG. \$1.40.	DESIGNING WROUGHT AND CAST IRON WORK, by H. ADAMS. Paper. Three parts, 60 cents each.
	DIGEST OF GAS LAW. \$5.	NOTES IN MECHANICAL ENGINEERING, by H. ADAMS. \$1.
		STRAINS IN IRONWORK, by H. ADAMS. With plates. \$1.75

The above will be forwarded by express, upon receipt of price. If sent by mail, postage must be added to above prices. We take especial pains in securing and forwarding any other Works that may be desired, upon receipt of order. All remittances should be made by check, draft, or post office money order.

A. M. CALLENDER & CO., 42 Pine Street, New York.

GAS METERS.

GAS METERS.

GAS METERS.

GEO. J. MCGOURKEY, Prest.

WM. H. MCFADDEN, Vice-Prest. (Phila.)

WM. N. MILSTED, Gen. Supt. and Treas. (New York).

WM. H. DOWN, Sec.

THE AMERICAN METER CO.

WET AND DRY GAS METERS.

PRESSURE REGISTERS.

METER PROVERS.

STATION METERS.

PRESSURE & VACUUM REGISTERS.

PORTABLE TEST METERS.

EXHAUSTER GOVERNORS.

PRESSURE & VACUUM GAUGES.

EXPERIMENTAL METERS.

DRY CENTER VALVES.

CRESSON GAS REGULATORS.

AMMONIA TEST METERS.

GOVERNORS FOR GAS WORKS.

MARSLAND WATER METERS.

BAR & JET PHOTOMETERS.

Manufactories:

512 West 22d St., N. Y.

Arch & 22d Sts., Phila.

GAS STOVES.

SUGG'S "STANDARD" ARGAND BURNERS,
SUGG'S ILLUMINATING POWER METER,
Wet Meters, with Lizar's "Invariable Measuring" Drum.

Agencies:

177 Elm Street, Cincinnati.
244 & 246 N. Wells Street, Chicago.
810 North Second Street, St. Louis.
222 Sutter Street, San Francisco.

HELME & McILHENNY,

(Established 1848.)

GAS METER MANUFACTURERS,

Nos. 1339 to 1349 Cherry Street, Philadelphia, Pa.,

WET AND DRY GAS METERS, STATION METERS, EXPERIMENTAL METERS, METER PROVERS,

Center Seals, Pressure Registers, Governors, Indicators, Photometers, and all other kinds of Apparatus for use in Gas Works.

FOULIS' PATENT STATION AND DISTRICT GOVERNORS.

REPAIRING DEPARTMENT.—We employ a special force of skilled workmen repairing meters of all makers.

WM WALLACE GOODWIN, Prest. and Treas.

WM. H. MERRICK, Vice-Prest.

S. L. JONES, Sec.

S. V. MERRICK, Supt.

THE GOODWIN GAS STOVE AND METER CO.,

Successors to W. W. GOODWIN & CO.

1012, 1014 and 1016 Filbert St., Phila., Pa.

142 Chambers St., New York City.

76 Dearborn, St., Chicago, Ills.

WALDO BROTHERS, Agents, 88 Water Streets, Boston, Mass.

MANUFACTURERS OF

DRY AND WET GAS METERS,

Station Meters (square, cylindrical, or in staves), Glazed Meters, King's and Sugg's Experimental Meters, Lamp Post Meters, etc., etc. Meter Provers (sizes 2, 5, and 10 feet), Pressure Gauges of all kinds, Pressure Registers, Pressure and Vacuum Registers, Pressure Indicators (sizes 4, 6, and 9 inch), King's Pressure and Vacuum Gauges, Dry and Wet Center Seals, Dry and Wet Governors, Exhauster Governors, Photometers of all descriptions. Letheby's Sulphur and Ammonia Test Apparatus complete. Also, Testing and Chemical Apparatus of all kinds, and of the most perfect description, for all purposes relating to Gas.

Manufacturers of the "SUN DIAL" GAS STOVES, for Cooking and Heating.

Goodwin's Improved Lowe's Jet Photometer.

Agents for Bray's Patent Gas Burners and Lanterns.

Special attention to Repairs of Meters and all Apparatus connected with the business. All work guaranteed first-class in every particular. Orders filled promptly.

G. B. EDWARDS, Manager, New York.

S. S. STRATTON, Manager, Chicago.

D. McDONALD & CO.,

GAS METER MANUFACTURERS.

(Established 1854.)

51 Lancaster St., Albany, N. Y. 34 & 36 West Monroe St., Chicago, Ill.

STATION METERS, EXPERIMENTAL METERS, METER PROVERS, PRESSURE & VACUUM REGISTERS, PRESSURE GAUGES, ETC

Also STAR GAS STOVES, RANGES, and HEATING STOVES.

We use only the very best materials, and employ the most skilled labor, and by our long experience (32 years) and personal supervision of every detail, we feel justified in assuring the public that our goods will give perfect satisfaction. Every Meter emanating from our establishment will bear the State Inspector's BADGE, and will be fully warranted by us. Our Annual and Calendar will be sent to Gas Companies upon application.

NEW ONE-THIRD HORSE POWER "OTTO" GAS ENGINE.

Fitted with
TUBE IGNITER,
and of
THE MOST SIMPLE
CONSTRUCTION.

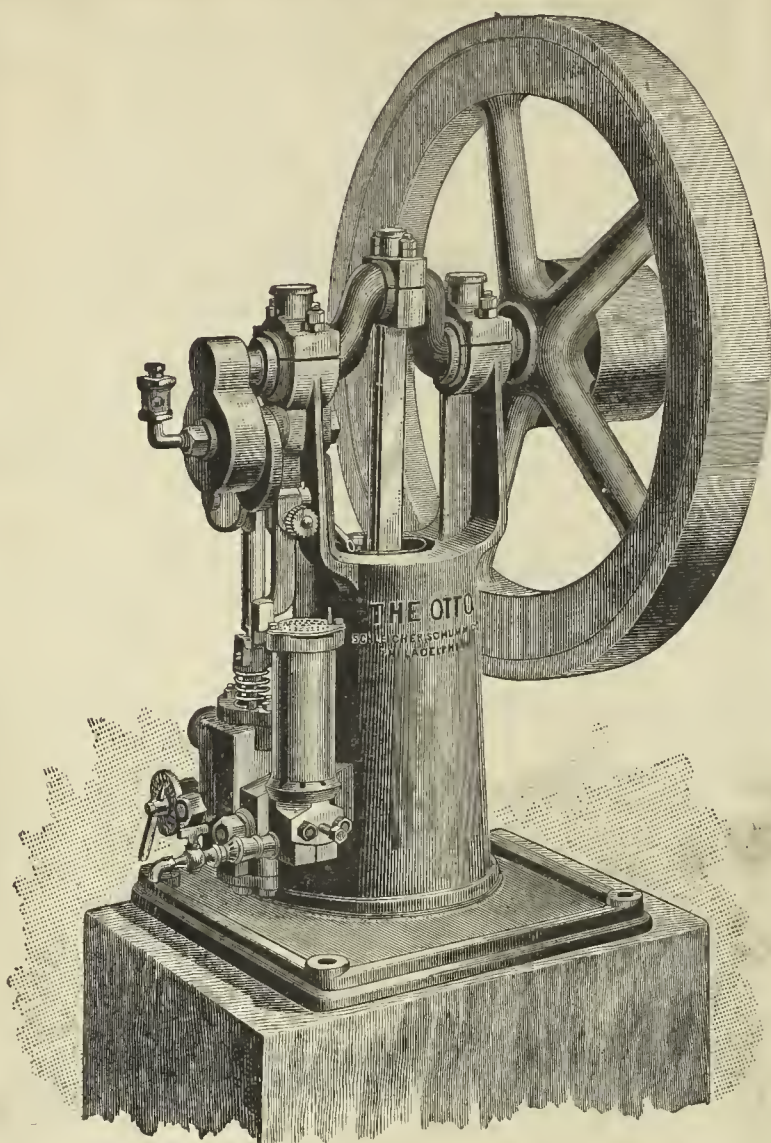

Will Regulate its
GAS CONSUMPTION
in
PROPORTION TO THE
WORK DONE.

Capable of Driving a No. 18 Enterprise or Star Coffee Mill, One Job Printing Press, Three to Four Fans, Dentists' Machinery, Amateur Tools, Household Pumps, Etc.

Many Valuable and Recent Improvements on all other Sizes,

AMONG WHICH ARE

INTERCHANGEABLE DUPLICATES OF SLIDES, PLATES, and COVERS,
Sent with each Engine Free of Charge. Also,

Power in Most Sizes has been Increased, while Floor Space has been Reduced.

SINGLE CYLINDERS AND TWIN ENGINES; HORIZONTALS AND VERTICALS, COMBINED WITH
WATER PUMPS, SEWAGE PUMPS, AIR COMPRESSORS, DYNAMOS, ETC.

Will Outdo in Economy and Every Other Respect the Rented or Electrical Power.

SIZES, 1-3d to 100 HORSE POWER.

"Otto Gas Engine Works,"

SCHLEICHER, SCHUMM & CO.,

151 Monroe St. (Kent Building), Chicago.

33d & Walnut Sts., Phila.

NEW YORK AGENCY, 18 VESEY STREET.

THE AMERICAN

GAS LIGHT JOURNAL

RODMAN & KENNY, N.Y.

PUBLISHING OFFICE No. 42 PINE STREET

DEVOTED TO THE INTERESTS OF ILLUMINATION, VENTILATION, WATER SUPPLY AND DISTRIBUTION, & GENERAL SCIENCE.

VOLUME LII.—No. 3. }
Whole No. 763.

NEW YORK, MONDAY, JANUARY 20, 1890.

{ \$3 PER ANNUM,
IN ADVANCE.

A. M. CALLENDER & CO., Proprietors. C. E. SANDERSON, Manager.
JOS. R. THOMAS, C.E., Editor. T. J. CUNNINGHAM, Asst. Editor.

ENTERED AT THE POST OFFICE AT NEW YORK, N. Y.
AS SECOND CLASS MATTER.

CONTENTS.

An Asterisk (*) denotes an illustrated article.

OFFICIAL NOTICE—

Annual Meeting, New England Association of Gas Engineers..... 69

EDITORIALS—

Briefly Told..... 69
Arc Lighting at Boston, Mass.—The Amendment was not Accepted by the Gas Company—An Application for an Opposition Charter at Freeport, Ills.—Suit for Damages—Processes and their Development in England During 1889.

CORRESPONDENCE—

Dr. Wilkinson Objects to the Figures..... 70
The Market for Gas Securities..... 70
*Another Step in the Granger Process..... 71
Pressure Gauges and Exhaust Registers..... 71
*The Alexander and Paterson Process of Making Oil Gas..... 72
The Illinois Coal Industry..... 73
Methods of Lighting Work on the New Croton Aqueduct..... 74
*Former for Square Pipe..... 75
The Lighting of an Imperial Railway Train..... 75
Electric Lighting of Ships..... 75
Conversion of Gas Globes into Regenerative Lamps, by D. R. Gardner..... 75

ITEMS OF INTEREST FROM VARIOUS LOCALITIES..... 77

Progress at Poughkeepsie, N. Y.—A Hint from Eufaula, Ala.—Changes at Cumberland, Md.—Mr. Cabot at Home Again—Contracts Awarded to Mr. Weber—An Electric Freak at Birmingham, Ala.—Bids for Public Lighting, Brooklyn, N. Y.—Public Lighting, Boston, Mass.—Can the Successful Contractors Carry out their Promise?—Experimenting with the Gordon Lamp, Troy, N.Y.—Gas Company for Monterey, Mexico—Main Extensions at Savannah, Ga.—Asking for Another Investigation at Washington, D. C.—Cost of the Eight Hour Labor Proposition, Philadelphia, Pa.—Cincinnati to Have an Electrical Engineer—Mayor Davidson and the Baltimore Consolidated Company—Annual Election, Laclède Gas Company—Quality of Philadelphia Gas—Proposition to Regulate Gas Rates in St. Louis—Breckenridge Cannel for Rio de Janeiro—Cheaper Gas for Galesburg, Ills.—Annual Meeting, Peoples Company, Cleveland, O.—Annual Meeting, White Plains (N. Y.) Company—And Many Other Items.

Corrosion..... 79

It is with sincere regret that we announce the death of Oliver E. Cushing, Agent of the Lowell (Mass.) Gas Light Company, who died Friday, 17th inst.

[OFFICIAL NOTICE.]

New England Association of Gas Engineers.

SECRETARY'S OFFICE, BIRMINGHAM, CONN., Jan. 10, 1890.

The Twentieth Annual Meeting of the New England Association of Gas Engineers will be held at Young's Hotel, Boston, on Wednesday and Thursday, Feb. 19th and 20th. The meeting will be called to order on Wednesday, at 10 A.M., by the President, Mr. R. B. Taber.

At the present moment it is impossible to give a list of the papers which will be read at the meeting, but it is hoped that the literary part of the programme will equal any of those held in past years.

Persons eligible for membership who desire to join the Association will please communicate with the Secretary, who will forward at once blank form of application.

CHARLES H. NETTLETON, Sec'y.

BRIEFLY TOLD.

ARC LIGHTING AT BOSTON, MASS.—Our item columns contain an account of the award for public lighting by means of arcs in Boston for the current year, the bulk of which is to be performed by the Suburban Light and Power Company, at its bid of 39.74 cents per night per light for city proper, and 39.99 cents for the Roxbury district. The Boston Electric Light Company refused to tender for the work because the new set of specifications provided that the maximum rate that would be considered should not exceed 40 cents per light per night, the refusal being based on the fact that at the maximum rate the Company would not be serving the interests of its stockholders did it attempt to secure the work. The Charlestown Gas Company, that had been performing the arc lighting for the Charlestown district, also refused to tender, and for similar reasons to those submitted by the other Company; but we understand that the Charlestown proprietors have reconsidered their former determination, and have since agreed to go on with the lighting of the district at the rate of 40 cents per arc per night. This later action we presume may be fairly taken as indicative of the fact that the Gas Company can supply electric currents for lighting more economically than can be done by an independent Company. But be this as it may, we are just now more concerned with the reasons put forward by President Gilbert, of the Boston Electric Light Company, in defending, or rather explaining, his action in the matter of refusing to submit a tender. Having asserted that the officers and directors of the Company proposed to do all in their power to protect the amount of money invested by the stockholders in their business, he stated that he was perfectly willing to leave the settlement of a contract price to the decision of the State Board of Gas and Electric Light Commissioners, or would consent to an inspection of the Company's books by an expert or experts to be named by the Mayor, and abide by the result. Continuing, President Gilbert said: "If Mayor Hart had removed the restriction of a 40-cent limit, the Company could have put in a bid of 50 cents for districts where the housetops are wired, and for the remaining circuits an offer for a lower figure could have been made that would have brought the total average expense below 50 cents a light per night. At present it costs the Company 47 cents per light to illuminate the streets, hence, and simply from a business standpoint, the Company could not make an offer of 40 cents, on the basis more particularly of a yearly contract." From President Gilbert's statement it would seem that arc lighting (that is, where a fair attempt to keep up to the candle power named in the specifications is the rule) is not a great bonanza at rates that are even largely in excess of many now maintained at various points in the country. President Gilbert's statement, in any event, has the merit of being plain, if not blunt.

THE AMENDMENT WAS NOT ACCEPTED BY THE GAS COMPANY.—The following item was printed in our issue for January 13th: "The Pawtucket (R. I.) Common Council has amended its contract for public lighting with the Pawtucket Gas and Electric Light Company so that the 2,000-candle power arcs now supplied on the all-night schedule may be changed to half arcs." Naturally this conveyed the intimation that the ordinance or agreement had been adopted by the Council and accepted by the Company. This, however, was not the result; the amendment

or order was only introduced, and the Gas Company negatived the proposition.

AN APPLICATION FOR AN OPPOSITION CHARTER AT FREEPORT, ILLS.—At a meeting of the City Council of Freeport, held on the 6th inst., Clerk Osborne read a lengthy ordinance, based on a proposition from Nathan Shelton, regulating the acts and prospects of an opposition gas company. The promoters propose to supply an uncarbureted fuel gas, under the Evans process, and to charge the consumers for it at the rate of \$1 per 1,000. Ald. Holland, immediately on the reading of the proposition, after asserting his belief that such a measure should receive careful attention, moved that a committee of three, acting in conjunction with the Mayor, should be appointed to sift the matter thoroughly. This opinion was concurred in by the Council, and the Mayor appointed Messrs. Holland, Brunn and Flachmeir as such committee. The Freeport Gas Light and Coke Company charges from \$1.80 to \$2.25 per 1,000 cubic feet for a good quality of illuminating gas, and its service so far has given good satisfaction to the residents. We imagine, however, that if the Council Committee gives the proposed ordinance a careful scanning, and goes thoroughly into the aims and objects of those who are backing it, the project will not be indorsed by the authorities.

SUIT FOR DAMAGES.—In the suit of Mr. J. S. Brown, of Bishop street, Montreal, who asks for \$800 damages against the Gas Company, alleging that his family's health was injured because of gas that escaped into his residence from a fractured street main, defendant has called the city into the case to guarantee it against the outcome of the suit. This is asked for because the main in question was fractured by the impact from a heavy steam roller used by the city in the operation of macadamizing Bishop street.

PROCESSES AND THEIR DEVELOPMENT IN ENGLAND DURING 1889.—In its retrospect for the last year, the *London Journal* thus makes mention of certain new processes and inventions in the gas industry:

"A fair number of new processes and inventions in connection with gas making have attracted public attention during the past year. There has been a distinct revival of speculation in new or ostensibly novel descriptions of illuminating and fuel gas. To say little of such devices as the Lawrence automatic gas, which is simply gas carbureted with petroleum spirit, or the Lothammer gas, which is carbureted under pressure with the same material, notice must be taken of the remarkable 'boom' in water gas, which was secured by the clever financial operations of the promoters of the British Water Gas Syndicate. The £5 shares of this venture (£3 paid) were at one time forced up to £26; and two concessionary companies were launched before the bubble collapsed. The question of the possibility of utilizing water gas plant as an auxiliary to the coal gas plant in British gas works, previously regarded as impracticable on the score of expense of production, was seriously raised towards the close of the year, when the Directors of the Gas Light and Coke Company sent their Chief Engineer (Mr. G. C. Trewby) to the United States to inquire into this and other matters of which American gas engineers have special knowledge. Several American gas engineers of experience in water gas manufacture came to this country about the same time with a view to demonstrating the practicability of making carbureted water gas here at a cost comparable with that of ordinary coal gas. It was reported that at least two, and perhaps more, of the London Gas Companies contemplated putting these claims to the proof of experiment on a working scale; and a working water gas plant has actually been erected by the Van Steenberg syndicate at Humphreys' Hall, Knightsbridge. Meanwhile pressing labor troubles caused attention to be given in increased measure to devices for reducing the handiwork of coal gas manufacture. Favorable notice was taken of the inclined retort settings of M. Coze, of Rheims, the successful working of which with English caking coal was proved to the satisfaction of a deputation of representative English engineers who visited Rheims for the purpose. M. Coze's success has already attracted a host of imitators, with whom he will probably have to fight for his profits if his system, or anything like it, should be generally adopted.

"The Dinsmore process of improving coal gas by carbonizing the tar has been partially adopted at Widnes, and is being experimented with in some other places. Mr. Valon, at Ramsgate, has developed a process for the production and use of pure oxygen in gas purification, by an ingenious modification of the Brin process for separating oxygen from the atmosphere. The Claus system of continuous gas purification by liquids in closed vessels was adopted at the Belfast gas works and used successfully for 72 days, when there was a complete breakdown of the pumps attached to the apparatus, which proved to be of unsuitable pattern. The capability of the plant, when in proper order, and the reliability of

the system for dealing with a daily make of 1,600,000 cubic feet of gas, were, however, established; and the apparatus is shortly to be started again with new pumps. The interesting problem of dispensing, wholly or in part, with the lofty guide-framing of gasholders, received further elucidation from the continued success of the Rotherhithe experiment, in which a triple-lift holder has framing only to the height of the second lift. The example was followed in designs for enlarging several other holders belonging to the South Metropolitan Company. Mr. W. Gadd, of Manchester, brought out a patented invention for guiding gasholders from the base, which was to be tried on a holder not yet finished, at Northwich. Mr. E. Lloyd Pease, of the firm of Messrs. Ashmore, Benson, Pease & Co., of Stockton, patented a system of rope-guiding for gasholders, which was tried with success on a holder at Haslingden."

The Market for Gas Securities.

During the week the market for city gas shares was strong even to buoyancy, although the actual number of transfers was not exceptionally large. Consolidated sold up to 96½, and then reacted somewhat, but at no time did it go below 95½, the highest point of the previous week. To-day (Friday, Jan. 17) opening sales were made at 95½, and some brokers predict that lower figures will be recorded. We, however, do not share this belief, unless a considerable disturbance in the loan market takes place. Other city shares are also strong.

Brooklyn shares are well up to the mark, with every indication that important developments in respect to consolidation of interests will shortly take place.

The event of the week in New York proposed gas legislation was the introduction by Senator Roesch, on the 16th inst., in the State Senate, of a bill amending the gas companies' act to the extent of empowering gas companies to borrow money to pay debts or extend operations by bonds issued on franchise or property, not to exceed in amount the capital stock, the issue to be made only with the consent of two-thirds of the stockholders.

In out-of-town shares the most notable showing is made by the Consolidated Company, of Baltimore, the bid rate having been advanced thereon to 55, holders offering at ½ point higher. This is an advance of 5 points for the week.

Bay State (Boston) common is inquired for at 23, while Laclede common is offered at 18½. Chicago Trusts are at 46 bid.

It is likely that American capital will be invoked to carry out the provisions of a franchise recently granted by the authorities of Monterey, Mexico, for the operation of a gas works at that point.

Correspondence

[The JOURNAL is not responsible for the opinions expressed by correspondents.]

Dr. Wilkinson Objects to the Figures.

NEW YORK CITY, Jan. 11, 1890.

To the Editor AMERICAN GAS LIGHT JOURNAL:

My attention has been called to the article "A Question and an Answer," in your JOURNAL, December 9th, 1889.

Mr. Smithson does not give you the whole story as to what the new gas company propose to do. In the first place, they have a complete coal gas plant of sufficient capacity to make coke for the balance of the works, which will consist of a process of "wood water gas," so successfully used for several years at the New York Mutual Company's works. We there found that wood of no matter what kind, oak, chestnut, pine (fat or lean), hemlock, bark, etc., would in every case produce the same number of cubic feet per pound; the average for the whole time being 55,000 cubic feet per cord.

The process is patented, and has not been used in works named by you. It is entirely different in working and results from the usual wood-gas making; hence the figures you give do not apply. We all know what Australian shale will do as an enricher, and the figures you quote have been far exceeded by the process we propose.

Again, it is by no means certain that we shall use shale; for I have before me a sample of oil that can be had in any quantities—1,000 barrels per day, if wanted—delivered in San Francisco at a price that will enable the company to deliver gas (of 25-candle power) in holder at about one-half the price named by you.

As a rule, I do not answer such statements; but when I have the figures of actual work I feel it a duty to give them to the profession.

A. W. WILKINSON, M. D.,
Chemist to the Mutual and Equitable Gas Light Companies, N. Y. city.

Another Step in the Granger Process.

Letters patent (No. 418,711) were granted, on January 7, to Arthur O. Granger, of Philadelphia, for an improvement in a gas making process, the apparatus for which was patented by him on January 9, 1885, the serial number of the patent being 152,385. The specification submitted with his latest effort is as follows :

My invention has reference to a process for the manufacture of water gas ; and it consists in first heating up a bed of carbon in a generator, and with the products of combustion therefrom heating up a superheater or fixing chamber by internal combustion, then passing steam into the bed of carbon producing water gas, then passing the water gas, mixed with carbureting fluid, through the superheater, entering at the end where it is least hot, and causing it to pass through the superheater, gradually entering a zone of greater temperature, until it finally escapes to the washer or holder from the end which is hottest, as is fully set forth in the following specification and referred to in the claim.

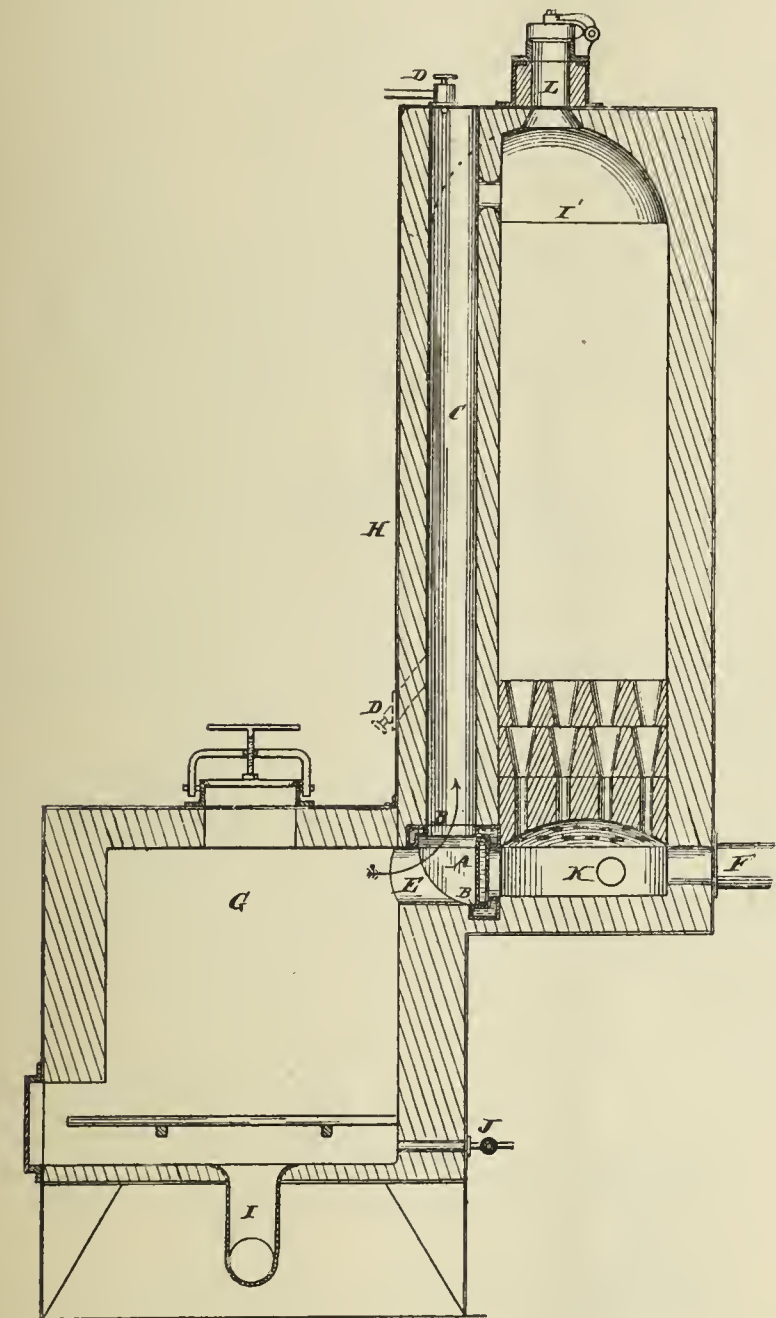

The object of my invention is to insure the illuminating gas passing into the superheater, at least the hot portion, and leaving the same at its hottest part, by which the thorough decomposition and fixing of the gases result, and at the same time the production of lampblack is entirely overcome. In apparatus in which the hydrocarbon vapors or liquids are caused to enter the superheater at its hottest portion of the hydrocarbon is instantly converted into lampblack and fixed upon the filling or lining of the superheater. By overcoming this production of lampblack I greatly increase the production of illuminating gas, as well as improve the working of the apparatus.

In the drawing is shown a sectional elevation of water gas apparatus in which to carry out my improved process.

H is a superheater, and *G* is a generator, which are connected together in any suitable manner, as by the connecting flue or passageway *E*, which opens from the top of the generator into the bottom of the superheater, or by an auxiliary flue connecting with the upper part of the said superheater. The generator is provided, as usual, with the blast pipe *I* and the steam pipe *J*, preferably entering below the grate bars.

The superheater *H* is provided with a lower combustion chamber *K* and auxiliary flue *C*, connecting the flue *E* with the upper part of the said superheater and above the filling *I*.

A is a water-cooled valve and works on the water-cooled seat *B*, and is adapted to close the entrance to the chamber *K* or the flue *C*, by which the product from the generator may be caused to pass either into the chamber *K* or the flue *C*, as desired, thus causing the said products to pass into the top or bottom of the superheater.

L is the smoke outlet opening from the top of the superheater, and *F* is the gas outlet opening from the chamber *K* and connecting with the usual water seal or washer.

D is the hydrocarbon spraying nozzle, which admits hydrocarbon fluid into the upper part of the superheater, preferably where the water gas, which passes through the flue *C*, enters the superheater. If desired, the fluid hydrocarbon may be admitted anywhere in the flue *C* or in the superheater proper, or it might be admitted in the generator.

In making gas the valve *A* is turned up, so as to close the flue *C* and open the passageway from the generator into the bottom of the superheater or its chamber *K*. The smoke outlet *L* is opened and the blast from pipe *I* is turned on. The coal in the generator is brought to incandescence by the blast from the pipe *I*, and the products are caused to pass into the chamber *K*, and are burned therein, the products therefrom passing up through the filling or internal brickwork of the superheater and escaping by the chimney outlet. The air blast from pipe *I* is then shut off, chimney *L* is closed, and valve *A* turned so as to close the entrance to the chamber *K* from the generator and open the auxiliary flue *C*. Steam is then admitted from pipe *J*, which, in passing up through the generator, is decomposed, forming carbonic oxide and hydrogen, which are conducted up through the flue *C* to the upper end of the superheater, where they are preferably brought in contact with a carbureting fluid from nozzle *D*, and the mixed gases then pass down through the superheater, entering that portion thereof which is least hot and emerging from that part which is hottest, becoming thoroughly incorporated and fixed into an illuminating gas, which then passes off by flue *F* through the usual water seal to the holder, if desired, preferably passing through purifying apparatus before reaching the said holder.

If desired, the auxiliary flue *C* might be separate and distinct from the superheater and built in the form of an external tube, and in place of one valve, *A*, two valves may be used, one controlling the entrance to the bottom of the superheater or chamber *K*, and the other the auxiliary flue thereof ; and it is evident that the smoke outlet might be from pipe *F* and the gas outlet from *L* ; but of course in this case the hydrocarbon nozzle *D* would be located at the bottom of the superheater or in the chamber *K*, the principle involved being identical with that hereinbefore described.

It is immaterial to my invention what the construction of the generator may be or what location may be given to the gas outlet or the steam and blast pipes.

Pressure Gauges and Pressure and Exhaust Registers.

W. Ralph Herring, in his articles on the "Construction of Gas Works," now running in the *English Gas Review*, makes the following remarks on the pieces of apparatus mentioned in the headline:

Pressure Gauges.—Gas as generated from the coal during the process of destructive distillation when subjected to the ordinary pressure existing in the apparatus of gas works, assumes a volume about 380 times greater than the coal from which it is extracted; and this volume is capable of augmentation and diminution by the effect of the variable atmospheric pressure and temperature. For the purpose of appreciating the various pressures to which the gas is subjected in the apparatus on the works, the water gauge is employed, which, in its simplest form, consists of a glass tube of about five-eighths of an inch internal diameter, bent in the form of a letter U. This tube is half filled with water, and a scale divided into inches and tenths of an inch is placed between the two tubes. One of the ends of the tube is covered by a perforated cap, while the other is made to communicate with the apparatus it is intended for. The gas pressure will depress the water in the tube to which it is connected, and raise it in a corresponding degree in the other tube; and the distance between the two levels indicates the pressure, which up to two or three inches is generally described in "tenths," and above this amount the term inches is applied.

The tubes are usually of equal diameter, so that the depression in one is equal to the rise in the other; but when two tubes of unequal diameters are employed, such as when a small tube is placed inside a larger one, the depression and elevation of the liquid is in proportion to their respective areas. At one period, when the baneful effects of heavy pres-

sure were not understood, it was by no means unusual to find a pressure of 30 or even 40 inches in some works, occasioned by small or choked mains and by defective purifiers. In these cases mercurial pressure gauges were used, which are similar to the water gauge, but having tubes of only a quarter of an inch in diameter, and as mercury is about thirteen and a half to fourteen times heavier than water, these gauges were made proportionately shorter. Thus a column of 30 inches of water would be substituted by a mercurial gauge of $2\frac{1}{4}$ inches in length; but, with the advanced knowledge now prevailing, such pressure should never exist; at the present time, therefore, the mercurial gauge is no longer in requisition, and any slight variations in the pressure are not nearly so well indicated by this as with the water gauge.

If tubes of unequal area are employed—say the one of ten times larger sectional area than the other—the water will be depressed nine-tenths in the smaller, and elevated but one-tenth in the large tube, and, by taking advantage of this circumstance, the pressure gauge can be made to indicate with one tube only, which in some cases may be desirable.

In all the various parts of gas works, whether in the retort house or on the apparatus, the simple tube gauge is preferable to all others, as there is no likelihood of its being [disarranged, whereas with other descriptions, if the water is not maintained strictly at the level, or when roughly handled, they are liable to mislead. By means of the gauge we are enabled to know the exact pressure existing in any part of the works, and from this ascertain the existence of any obstruction, either in the connections or in the apparatus, and stoppages in the district mains are, likewise, readily detected by its aid.

It is, for the before-mentioned reasons, important that a pressure-gauge be fixed to the inlet and outlet of each piece of apparatus through which the gas has to pass. In some cases, such as the washers, and more particularly the purifiers, one gauge on the inlet of each is sufficient, as the difference between the one and the other indicates the pressure.

Pressure and Exhaust Registers.—The principle of the action of these instruments is the same as that of the foregoing, with the important difference in make that they record as well as indicate the pressure or exhaust, as the case may be. This is accomplished by means of a float in water to which a vertical spindle is attached, having a lead pencil at the upper end, pressing upon a cylindrical graduated roll of paper upon a drum which is caused to revolve by clockwork once in the twenty-four hours, the paper roll being renewed daily.

The exhaust register should be connected to the mains at a point on the inlet side, and the record shows exactly whether the exhauster has been kept working with regularity.

The pressure register is in communication with the street mains, beyond the governor, and records the various pressures maintained therein during the day and night. The difference between the exhaust and pressure registers is simply one of detail in construction.

King's pressure-gauge works on somewhat the same principle, viz., a float in a suitable vessel of water. A cord is attached to the float, and passes over a small pulley on a spindle running in roller bearings. On one end of the spindle is a fixed pointer, which moves in front of a semi-circular dial, on which are inscribed very fine divisions indicating the pressure according to the rising or falling of water line caused by the pressure of the gas. This gauge indicates much finer variations of pressure, but is not used much, except when in skilled hands, as the loss of water by evaporation requires to be constantly made up, otherwise the indicators would be incorrect. This disadvantage has been quite recently overcome by the introduction of Messrs. Harrison and Sheard's patent mercurial gas pressure-gauge, Messrs. W. and B. Cowan (of Smith Square Works, Westminster, S. W.) being the manufacturers. It is a most convenient and portable appliance, and is constructed on the principle of the "King's" gauge, but with mercury to operate the float instead of water, thus absolutely overcoming the difficulty of loss by evaporation. To the float is attached a small spindle, on the upper end of which is a rack, which actuates a pinion on the pointed spindle. The dial can, when required, be made to indicate vacuum and pressure. The top of the float-chamber is arranged in such a manner that even if the gauge were turned upside down the mercury could not escape, thus allowing the instrument to be carried from place to place without fear of derangement. This is a very valuable instrument, and one that should be in the hands of all gas managers. I see no reason why the principle of substituting mercury for water should not be applied to the gauges on jet photometers, as now, with water, and in hot rooms, the level of the water requires constantly adjusting, and one can scarcely even look at the jet without the question presenting itself to the mind, "Is the water-line right?"

The Alexander and Paterson Process of Making Oil Gas.

Letters Patent (No. 419,098) were granted on the 7th inst., to Messrs. Thomas and Samuel Alexander, of Kirkintilloch, Scotland, and Robert Paterson, of Glasgow, Scotland, for an improved apparatus for making oil gas—the matters had already been protected by English patents—the principal features of which are outlined in the following specification. The inventers say:

Our invention has for its object, by improved, simple, and easily managed apparatus, to make gas of good quality from oil, the same be-

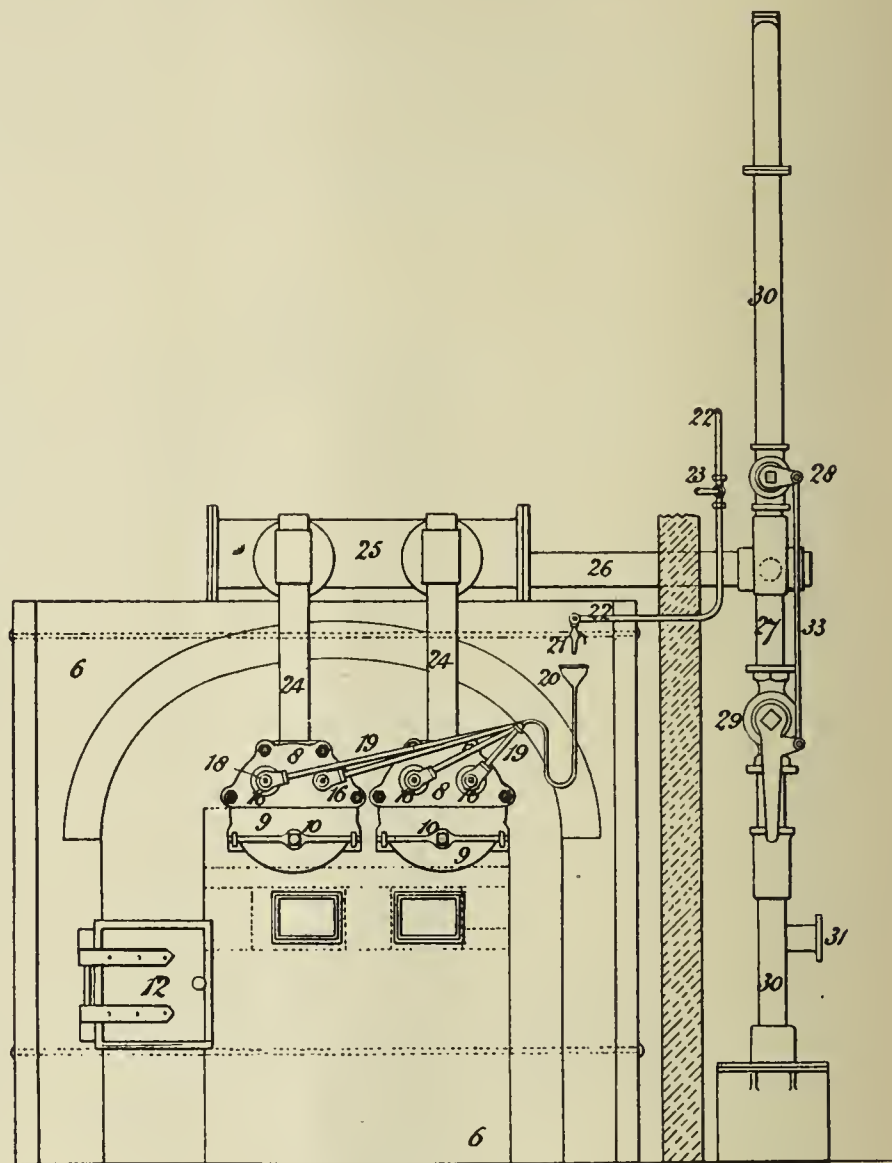

Fig. 1.

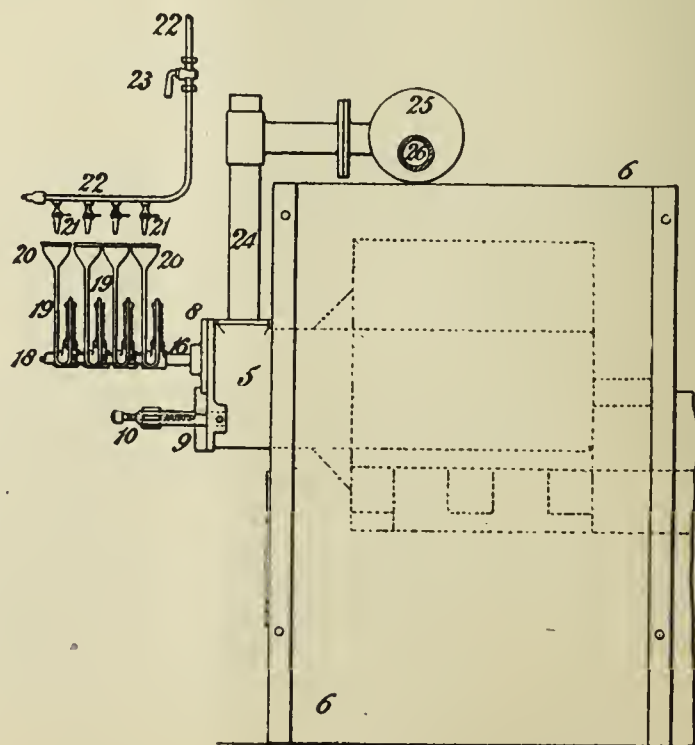

Fig. 2.

ing specially designed for use at country houses or in connection with works or other buildings where gas is made on the premises.

In carrying out our invention we employ one or more horizontal retorts of a cylindrical form arranged in a building with a fire grate and flues suitable for heating the retorts with ordinary fuel. The oil to be

converted into gas, and which is by preference purified petroleum or mineral oil, is led into each retort by two or more straight horizontal pipes placed near the inner surface of the retort, by preference at the upper part, and extending from the front end of the retort nearly to the back end, the inner ends of the pipes being open. The oil is partly converted in passing along the horizontal pipes and issuing from their inner ends. The vapor or gas is further acted on by the heat in passing from the back to the front end of the retort, at which latter part the outlet is situated.

Minor improved details, upon which the practical success of the apparatus largely depends, are hereinafter described.

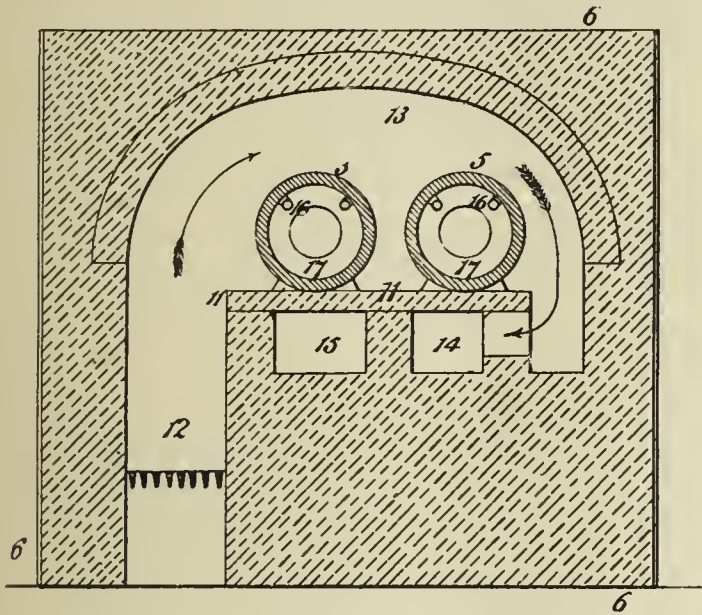

Fig. 3.

In the accompanying drawings, Figs. 1 and 2 are front and side elevations; and Figs. 3 and 4 are vertical sections, as at right angles to each other.

In the apparatus two cylindrical iron retorts 5 are placed in a brick building 6, the back ends of the retorts being formed with studs 7, by which they are supported in the back wall of the building. The front ends of the retorts project through the front wall of the building 6, and each retort is fitted with two end covers 8 9, each upper cover being bolted to the retort in a comparatively permanent manner, while each lower half 9 is held in place by a common bridle and screw 10, so that it can be easily opened for cleaning out the retort. Within the building 6 the retorts 5 rest on a horizontal fireclay slab 11, and the fire-place 12 is made at one side and communicates with an upper oven space 13, in which the retorts are situated. The fire gases pass over the retorts 5 and have free access to their sides, and then pass downward at the side further from the fire-place 12 and enter through ports into a flue 14, extending under one of the retorts. From the front end of the flue 14 the fire gases enter a flue 15 under the other retort and proceed along it to a chimney at the back (but not shown).

Through the top front cover 8 of each retort 5 two pipes 16 are fixed

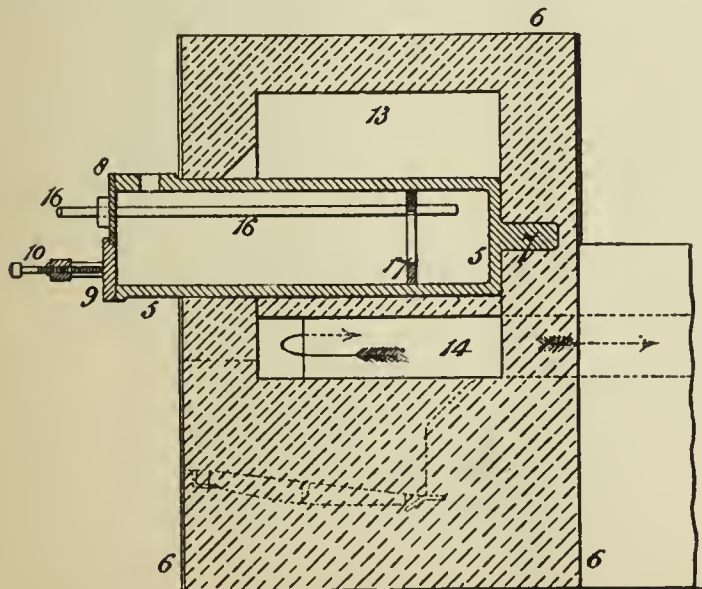

Fig. 4.

so as to extend along inside the retort near its upper internal surface to within a short distance of the inner end of the retort. These pipes 16 have their inner ends open, and are supported near their inner ends by a ring 17, placed inside of the retort, and which ring divides the retort into oil or gas chambers. The pipes 16 are made quite straight to facili-

tate the cleaning, and each is fitted with a screw-plug 18 at its front end which can be withdrawn to admit a cleaning instrument. The oil is led into each pipe 16 at one side, near its outer end, by a pipe 19, made with a siphon bend and provided with a funnel 20 at its outer end. Each retort pipe 16 is separately supplied with oil, the several funnels 20 being for convenience arranged in a horizontal row beneath separate stop-cocks 21 upon a main supply pipe 22, fitted with a main stop-cock 23, and connected with an oil tank (which is not shown, but which should be placed at a level a little higher than the stop-cocks 21). The total supply of oil can be regulated by the main stop-cock 23, while the portion of the supply allotted to each retort pipe 16 can be separately regulated by the branch stop-cocks 21. The gas formed in the retorts 5 passes off by ascension-pipes 24, connected to their front ends at the tops, into a main 25, and thence by a pipe 26 into a vertical pipe 27, which is provided with two stop-cocks 28 29, one above and the other below the junction of the pipe 26. The upper stop-cock 28, when open, communicates directly with the atmosphere, and the lower one 29 communicates with an ordinary assemblage of pipes 30, known as an air condenser, the set of these pipes 30 being supposed to be seen in edge view in Fig. 1 and to be extending backward. A branch pipe 31 (shown in Fig. 1) is at the back end of the condenser, and is for the attachment of a pipe leading to a gasholder of any convenient kind. The lever handles of the two stop-cocks 28 29 are connected by a rod 33 in such way that the action of opening one closes the other. When freshly starting to make gas the upper stop-cock 28 may be opened to allow the gas or vapor first formed, and which is mixed with air, to escape to the atmosphere instead of mixing with any good gas there may be in the condenser and gasholder. The gasholder drum is counterbalanced by weights made sufficiently heavy to raise it and produce a partial vacuum inside of it for the purpose of drawing the gas from the retorts and through the condenser and piping. This arrangement makes it necessary to provide the two connected stop-cocks 28 29, hereinbefore described, and the closing of the lower one 29 when the upper one 28 is open prevents air from being drawn in by the action of the partial vacuum.

Our improved apparatus, as hereinbefore described, is such as to allow of the action being easily and satisfactorily regulated and controlled, without which good gas cannot be formed economically and the apparatus cannot be kept in good order. With a suitable regular heat in the oven or flue space 13, it is essential for good working that neither more nor less than the proper supply of oil should be maintained. By opening the stop-cock 28 and allowing gas to issue from it its color will afford a means of judging whether the action is going on properly, and the attendant can adjust the supplies of oil or the heat from the furnace accordingly.

The Illinois Coal Industry.

The eighth annual compilation of statistics of the coal industry of Illinois has just been completed by Col. Lord, Secretary of the State Board of Labor Statistics, and is ready for publication. The record for the year ending July 1, 1889, shows the following summaries from the reports of the several mine inspectors as compared with the preceding year:

	1889.	1888.
Number of tons of lump coal mined.....	11,597,963	11,855,188
Aggregate value of product at the mine.....	\$12,496,885	\$13,309,030
Average value per ton at the mines.....	\$1.0775	\$1.123
Number of employees of all kinds.....	30,076	29,410
Number of miners..	23,583	23,648
Number of other employees (including boys)..	6,943	5,762
Number of boys employed underground.....	859	868
Average price paid per ton for hand mining..	\$0.731	\$0.716
Number of men killed	42	55

The total fuel product, including what goes through as well as over the screens, for 1888 was 13,396,362 tons; and for 1889, 13,105,698 tons. There is a shortage of 694,452 tons in the northern half of the State, and an excess of 437,227 tons in the southern half over any previous year. Macoupin is the banner county, raising 1,202,187 tons. The average value of coal at the mines in the State has gradually declined from \$1.51 in 1882 to \$1.07 in 1889. This, however, gives little idea of the wide variation in values in different localities and under differing conditions. The extreme of prices reported is from 50 cents to \$2.25 per ton. Fifty cents per ton on the track is given as the average value of coal at several places in St. Clair county, and in one instance 60,000 tons are reported at this price. This is, however, altogether exceptional, and is the lowest price ever given the inspectors. Above this, prices range in the same vicinity from 62½ cents to \$1 per ton, giving an average for the

fifth district of 87 $\frac{7}{10}$ cents. In the second district, on the other hand, in the northwestern portion of the coal fields, prices range from \$1.25 to \$2.25 per ton at the pit, with an average of \$1.43. These extremes in prices are by no means arbitrary, but doubtless fairly indicate the actual difference in the cost of production; for competition is sufficiently active everywhere to keep prices close down to the cost of the coal.

In view of the mildness of the winter and the depression in trade occasioned by it, and more especially in view of the general suspension of operations in the northern field pending a settlement of the wages question during the last two months of the year, the falling off in the annual output is perhaps less than might have been expected. The number of mines and of men is slightly increased over all former years; the average value of the product has dropped from \$1.12 $\frac{1}{2}$ to \$1.07 $\frac{3}{4}$ per ton; the average number of days of active operations has fallen from 220 to 211; the price of hand-mining for the State at large is found to have slightly increased, and the number of fatal accidents has materially diminished. There has been rather more than the usual number of new mines opened, but a corresponding increase in the number closed, while the number of mining machines reported as in use is less by 37 than the number in use the year before.

The four mines from which have been delivered the greatest tonnage during the year and the only ones which have produced over 200,000 tons are the Chicago, Wilmington and Vermillion Coal Company, No. 1, at Streator, La Salle County; Consolidated Coal Company of St. Louis, No. 6, at Staunton, Macoupin County; Consolidated Coal Company, of St. Louis, No. 1, at Mount Olive, Macoupin County, and Pana Coal and Mining Company, Colliery No. 1, at Pana, Christian County—the total tons produced being 922,484. The average daily wages paid machine men indicate ruling rates of \$2.25 and \$2.50 per day for machine operators, \$1.75 for helpers, \$2 for blasters, \$1.75 for loaders, \$2 for timber men, \$1.50 and \$1.75 for laborers and \$2 for drillers. The average prices paid for mining by hand decreased from 80 cents per ton in 1883 to 73 cents in 1889, though in 1886 the average was as low as 67 $\frac{1}{2}$ cents. These are general averages by districts. The extremes show the lowest to be 31 $\frac{1}{2}$ cents and the highest \$1.50. The price paid for the greater portion of hand-mining is from 50 cents to 95 cents a ton, the latter in the thin web coal of Will and Grundy counties and the former in the high and dry seams of the southern fields.

This year the machine-mined coal is 21 per cent. of the entire product; last year it was 19 per cent. The increase in the output of this character is largely in the fourth district, and the decline in the first and fifth. Several new machines have been produced during the year and several experiments have been made in the use of electricity in the place of compressed air. The mine at Girard, in Macoupin County, has an electric plant on trial which is furnishing motive power to a new device for under-cutting the coal and at the same time furnishing a current for a system of electric light throughout the workings. With the gradual development of the coal resources of the State it is found that the number of operatives drawn there by the demands of this industry increases year by year, regardless of the fluctuations in trade in wages. This receives fresh illustration in the totals reported for this year, which has not been altogether a prosperous one, and yet the number of employees now in the State is reported as 30,076, or 666 more than in any previous year.

After rehearsing the history and results of the great wage controversy in Northern Illinois the report says: "Thus ended a strike which involved more men, more loss of time, more loss of good wages and of product, occasioned more distress, commanded more public sympathy and discussion, more public declarations of the points at issue by both parties, and at the same time was conducted with more patience and moderation on the part of the men in view of their number and distress, than any which has occurred in the history of coal mining in this State."

Methods of Lighting Work on the New Croton Aqueduct.

The *Engineering Record*, in the course of a series of articles on "Builders' and Contractors' Engineering and Plant," alludes in the following manner to the methods of lighting followed by the contractors in charge of the work on the new Croton Aqueduct:

The methods employed for lighting the tunnel of the new Croton Aqueduct during its construction were chosen by the different contractors to suit their own ideas as to system, except on that portion of the work where the orders to use improved methods were complied with.

On the Northern Division, where the work was executed by Brown, Howard & Company, kerosene lamps and gasoline torches were generally used, Each torch being provided with 15 burners, consumed a large amount of oxygen, nearly as much as 15 men would require, and

the smoke from the torches and lamps sometimes became so dense in the headings as to cause a stoppage of the work. When more torches were added to increase the light the increased amount of oxygen consumed and smoke evolved produced an opposite effect, making the lights so dim that the darkness was almost visible; while the lamp-black emitted by these lamps filled the lungs of all exposed to its influence.

The stationary lamps were constructed of tin, with a flat reservoir to hold the burning fluid, from which a small pipe extended down about 2 feet, and then projected horizontally about 10 inches, terminating in the burner. Hat lamps were used by the miners, in which miners' oil was burned with kerosene added to increase the flame. Candles were also occasionally used for hat lights.

These lights were also used by John Brunton & Company at the beginning of the work below Harlem River, but they were generally replaced by electric lights in December, 1886. As the headings on this portion of the work were advanced only a few hundred feet at that time the bad effect of the oil lamps was less noticeable.

Electricity was introduced on the Northern Division in 1886, but the lamps placed in the tunnel were very far apart. In the tunnel leading from shaft 2 the intervals between the lamps varied from 500 to 600 feet. At shaft 11 there were three lamps in 2,000 feet. In November and December, 1886, the official report showed that 7 electric lights were burning in the headings of shaft 2, and the same at shaft 3. At shaft 5, on December 21, 3 lamps were reported to be in use by the bricklayers, and 8 along the tunnel; but this is the only case where so many lamps were used. Two lamps were reported at shaft 6, and 4 at shaft 9. The full number of electric lamps given above was not burning all the time, but only at intervals, particularly in the tunnel. Frequent reports were made of from 5 to 7 gasoline torches being used by the bricklayers in one heading.

On the Southern Division, which was built by O'Brien & Clark, electric lights were the rule, and, consequently, the condition of the atmosphere was very much better. The lights were not frequent enough in the tunnel to permit one to travel about freely without the aid of lamps, but all points where work was in progress were well lighted by electricity. On a portion of the work 4 lamps were burning within 1,000 feet; but in other places they were 500 feet apart. The miners and muckers were provided with the usual hat lamps, but in some of the headings candles were used altogether for hat lights, especially at shafts 16 and 17.

An electric light plant was placed at nearly every shaft. A complete electric lighting plant would have required a steam boiler, an engine, a dynamo, and necessary lamps, but as boilers were provided for operating the compressors and hoisting engines at each shaft, the surplus power was generally sufficient for operating the dynamos. At many of the shafts the dynamos were placed in a room separated from the rest of the plant to guard against accidents.

The best location for the wires in the tunnel was up out of the way near the roof, and secured to the rock or the arch of the completed conduit. On a portion of the work the wires were placed only a few feet above the floor, where they were liable to cause accidents whenever the insulation became imperfect. The lamps were suspended from the center of roof, or at one side, as was most convenient.

The engines used for operating the dynamos were small, usually from 15 to 20 horse power, and the dynamos were adapted for divided arc lamps. To operate a full-sized arc lamp of 2,000-candle power requires about 1-horse power. The lamps used were of 1,200-candle power, which did not require more than $\frac{3}{4}$ of a horse power each. Only one plant supplied more than 15 lights, so that a 15-horse power engine gave ample power except where there was more than one dynamo at a shaft. At Shaft 30 there was a large dynamo with capacity for 30 lamps, which supplied the current for lighting 6 shafts, from Shaft 27 to 32, inclusive. The conditions here were different from those on any other portion of the line, and unusually favorable for lighting several shafts with a single plant, as these shafts were either located in Tenth avenue or adjacent to it, permitting the telegraph poles on the avenue to be used for carrying the wires between the shafts, which were only $\frac{1}{2}$ a mile apart or less.

The dynamos and conductors used on the Aqueduct were in use continuously day and night, and were subjected to pretty rough treatment, the wires being carried in wet shafts and tunnels, in process of construction, and having, with the lamps, to be shifted daily to permit blasting.

Lightning arresters, to protect the dynamos, were placed on the main current wire, outside of the stations, except in the Ball system, where the wet poles were expected to supply all the conduction needed.

The lamps used for arc lighting on the Aqueduct differed slightly from the ordinary lamps for street service, but the change was only that necessary to adapt them for rough usage.

The dynamos and lamps used for supplying light in the Aqueduct

shafts and tunnels were furnished by the following parties: the Bell Electric Light Company, New York City; the Thomson-Houston Electric Company, Boston, Mass.; the Schuyler Electric Company, Middletown, Conn.; the United States Electric Lighting Company, New York City, and the Brush Electric Company, New York City and Cleveland, Ohio.

Power for running the dynamos was supplied by engines of the following makes—viz.: Westinghouse, Payne, Lidgerwood, Greenfield, Sullivan & Ehlers, and the New York Safety Steam Power Company.

Former for Square Pipe.

The Pittsburgh Sheet Metal Tool Company, Limited, of Allegheny, Pa., is introducing to the trade a machine for forming square heater pipe, cans, boxes, etc., a general view of which is shown in the accompanying illustration. The manufacturers state that this is one of the best for the purpose which has ever been offered the trade, and that it will form a perfect angle up to 90° with one motion of the hand. It is designed for executing any description of square work. It is claimed to be speedy, accurate, and economical in operation. The arrangement of the gauges is such as to make it unnecessary to lay off the sheets to be formed, and that when once set long and short sides can be alternately made as readily and speedily as if but one gauge was employed. A

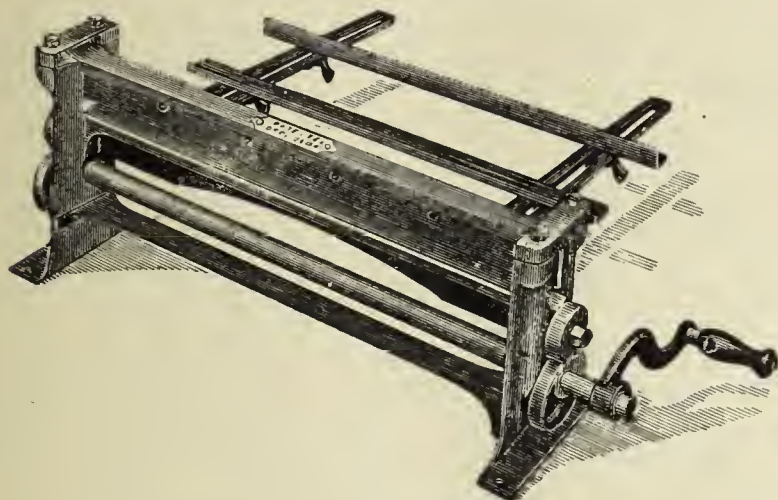

Machine for Forming Square Pipe.

careful inspection of the accompanying illustration will convey a very good idea of the general arrangement of parts, making a detailed description unnecessary in this connection. The machine weighs about 45 pounds, and may be employed on any bench without the necessity of fastening it down. It is said to be in use in a number of large manufacturing establishments in Pittsburgh and other cities, and those who have employed it speak in high terms of its operation.

The Lighting of an Imperial Railway Train.

M. Warchowsky, Engineer and General Inspector of the Russian railways, gives a description of the somewhat extensive electric lighting of the Imperial train which was adopted after preliminary experiments with a part of the train only. The firm of Jablockhoff & Co., of St. Petersburg, constructed and fitted the incandescent lamps, which are of 6 to 8-candle power at 30 volts, the conductors arranged with contacts between the carriages, the accumulators disposed in three groups, the apparatus for charging these accumulators, the voltmeters and ammeters, and also the dynamo. The steam engine for driving the dynamo is a Brotherhood 3-cylinder machine. The boiler, horizontal, with iron fire box and tubes, was made by Messrs. Nobel, St. Petersburg. The dynamo, steam engine, boiler, the battery of 36 accumulators, and the reservoir of water are fitted in the middle compartment of a wagon with four partitions specially constructed for the purpose. The other compartments containing the fittings and oil, the fire pumps, the Graftio apparatus for controlling the speed of the train, and, lastly, a Schwarzkopf apparatus for prevention of explosion of the boiler. The Imperial train consists in all of 15 carriages. The total number of lamps employed is 253, and they are disposed as follows: Electric wagon, 6; workshop wagon, 8; the Minister of Internal Communications, 22; the Czar's servants, 15; kitchen wagon, 13; buffet wagon, 13; dining-room car 26; Czarina's car, 18; Imperial car, 36; Grand Duke, 20; ladies-in-waiting, 21; body guard, 13; luggage, 7. All the incandescent lamps can be turned on or off separately by the aid of two cords, one red, the other black. Another battery of 18 accumulators is placed in the buffet

wagon, enclosed in a wood box; a third battery of the same number of cells is placed in the dining room car. The accumulators are charged by the main current from the dynamo. The engine is capable of working at 15-horse power, but works usually at about 12-horse power. In the carriages the lamps are distributed singly and in groups. The lamps are either obscured or fitted with ground glass shades, and in the Imperial car movable fittings are used.

When the whole of the train was completely fitted, the authorities made two thorough tests. First, the train when standing was lighted for 24 hours; secondly, the train was completely lighted during the journey from St. Petersburg to Moscow (400 miles), at an average speed of 35 miles an hour, at Moscow during a stoppage of 10 hours, and throughout the return journey to St. Petersburg. During the last test the dynamo was stopped for about two hours, and the accumulators completely charged were then used alone. The Imperial train during the journeyings of the Czar in 1888 ran a distance of more than 5,000 miles, and the electric light always worked well. The train was partially wrecked during the catastrophe of October, 1888, but the wagon on which was this rolling electric central station, which followed next to the tender of the second locomotive, was practically uninjured.

Electric Lighting of Ships.

Engineering says the past year has been notable for the large proportion of vessels fitted with the electric light, and also for the progress made in the economical and efficient production of that light. The speed of dynamos has formed one of the most important subjects of study by the electrician, and while in the case of almost all other engines greater speed is the desideratum, here the reduction of the number of revolutions is the aim sought after, for thereby is the life of the machine lengthened. We are now within a short distance of attaining 200 revolutions. The arc lamp, because of the great care it requires—and which is seldom given on shipboard—is being superseded by sunbeam and groups of high candle power lamps, which are adopted specially for cargo working. The relative advantages of single and double wires in ships is a bone of contention amongst electrical engineers; but the tendency is regarded as towards the single wire system, where with due care on the part of the engineer there is no likelihood of the compass being affected. Dynamos for incandescent lighting are of such low pressures as to insure complete safety of life. Danger alone lies in improper qualities of materials and indifferent workmanship. Steamers of all types now adopt the electric light, and this year the number of cargo vessels fitted with an installation has been most marked. It is used for all purposes, and in one particular respect in which the development is most noteworthy; it is the fitting of cargo boats with long cables which may be run from the ship over the wharves to light them up when cargo is being moved. It is too late in the day to speak of the general advantages of the electric light over the paraffine lamp.

The Conversion of Gas Globes into Regenerative Lamps.

[A paper read by Mr. D. R. Gardner, before the Glasgow (Scotland) Philosophical Society.]

The author began by stating that he was led up to the invention he was about to describe by his experience in connection with the consumption of smoke in boiler furnaces. Many years ago, after having been summoned for creating an alleged nuisance by smoke, he investigated the principle of consuming, or rather of preventing smoke; and he found that highly heated air, properly applied in the furnace, was all that was necessary. He afterwards proceeded to bring this principle to bear in the production of a regenerative gas lamp suitable for shops, halls, etc. He studiously avoided the method in which other inventors had carried out the principle of regeneration in gas lamps, and was led to supply the air from the bottom of the shade alone, and to control the draught by means of a damper at the top of the funnel, which, by being screwed up or down, adapted the lamp for burning gas of any quality or at any pressure. In like manner he carried out the same principle in ordinary gas globes or shades.

With the view of explaining the science of increasing light for illuminating gas, the author quoted from an article in "Ure's Dictionary of Manufactures and Mines," to show that the proper burning of illuminating gas depended upon certain physical and chemical conditions, the due observance of which was of great importance in the development of a maximum amount of light. Chief of these was the prevention of the escape of any particles of carbon unconsumed. He also referred

to Dr. Frankland's Argand burner, fitted with a double chimney for the purpose of highly heating the air; the result being that when 3.3 cubic feet of gas were consumed per hour with the single chimney, 13-candle power was yielded by the gas, whereas by employing the double chimney 21.7-candle power was developed. The double chimney was tried by the author before he was aware of its previous use; but he found it to be valueless, as the double glass considerably obstructed the light, and the dirt and moisture carried in by the current of air further obscured it. He then resorted to the ordinary globe, and discovered that by materially diminishing the outlet the flame materially increased in size. His thoughts were at once directed towards the materials and form best suited for a cover to the shade. Asbestos was tried, by moulding or fitting it on the globe; but when a high temperature was maintained the globes would occasionally crack. Latterly, after making various attempts to overcome this and other difficulties, the author hit upon the expedient of using small plates of mica between the asbestos and the glass shade as non-conductors of heat. Although he had subjected the shades to very severe tests, he had not since broken one. The cover might now be considered to be as simple and perfect as it was possible to make it, as it suited all qualities of gas, the different pressures, the vari-

increased luminosity to the carbon contained in the gas, and that it is necessary to retard the flow of gas at the burner. The question came to be: "Had those two points been attained by the application of the asbestos cover?" One experiment, he remarked, would be sufficient to demonstrate this. He caused a cloud of smoke from a piece of brown paper to enter the shade, which showed a quiet condition of the atmosphere around the flame, and consequently a retardation of the flow of gas at the burner, while the temperature of the surrounding air was raised to the point desiderated by Dr. Frankland for the combustion of the light carbureted hydrogen that passes off unconsumed from an ordinary gas flame. Mr. Gardner declared that he had burned a number of lights with the covers on in a small room for a couple of hours, and on returning to the room from the fresh air, he could not perceive the slightest unpleasantness in the atmosphere; whereas if the shades had been without covers the air of the room would have been both disagreeable and unhealthy.

The illuminating power attained by Glasgow gas by the use of the Gardner asbestos cover had been tested by Mr. Terrace, under the direction of Mr. Foulis, and the results were shown in a table exhibited, of which the following is a copy:

Description of Globes (Clear).	Tests with Union Jet Burners at 5-10ths Pressure.		Illuminating Power Corrected to Five Cubic Feet.			Increase per Cent. with Cover.	
	No.	Consumption per Hour. Cubic Feet.	Open Flame. Candles.	Globes without Cover. Candles.	Globes with Cover. Candles.	Open Flame as Standard. Per Cent.	Globes without Cover as Standard. Per Cent.
Comet.....	8	5.00	22.19	20.91	24.49	10.36	17.12
Squat.....	8	5.00	19.40	24.50	10.41	26.29
Nelson.....	8	5.00	22.25	20.25	24.61	10.60	21.53
Queen Anne.....	6	3.75	20.15	17.10	22.41	11.21	31.05
" ".....	4	2.75	15.49	13.25	18.83	21.56	42.11
Squat, small } 15-10ths.....	4	5.08	11.41	10.27	14.75	29.27	43.62
" large }.....	4	11.41	9.89	13.66	19.72	38.12
Nelson (ground, with flowers) 5-10ths....	8	5.00	22.35	14.35	19.68	37.14
Queen Anne (clear, with fern) at an angle of 45°, at 5-10ths.....	8	5.00	18.88	16.81	29.03	53.76	72.70
Queen Anne (clear) at an angle of 45°, at 5-10ths.....	4	2.75	9.59	21.15	120.50

ous sizes of burners, and could be used with the present shades and gas fittings by merely placing it on the shade and adjusting the regulator. The appliance has been patented in the United Kingdom, and will be in other countries.

The following is a brief description of the cover in the form now arrived at by the inventor: Sheet asbestos, specially prepared for the purpose, is cut into discs varying from 4 up to 7 $\frac{1}{4}$ inches in diameter, and rising $\frac{1}{4}$ inch to each size, so as to suit all the different sizes of shades. In order to hold the cover in its place three asbestos studs are fixed on its lower surface, moving in an eccentric, which allows the cover to be most perfectly fitted. Round the lower edge there are half-a-dozen discs of mica fixed. These act as non-conductors between the glass shade and the cover. In the center of the cover there is punched out an opening 1 $\frac{1}{4}$ inches in diameter, and the disc so removed is fixed by means of a stud to the cover at one side of the opening on which it turns—thus becoming a valve to regulate the size of the aperture according to the quality and quantity of gas used.

Mr. Gardner stated that he had recently called upon Mr. W. Foulis, the General Manager of the Glasgow Corporation Gas Department, to confer with him on the invention. This gentleman at once heartily took up the matter, and volunteered to have it subjected to a thorough scientific testing photometrically by Mr. D. Terrace at the Dawsholm Gas Works. The author then briefly referred to some of the papers on "The Economical Use of Gas," by Mr. Terrace and the late Dr. Wallace, and went on to state that the former gentleman, in showing that the improvement under consideration was not to be had from burners, said that in testing several of the devices intended to improve the ordinary open gas flame, he found no increase in luminosity per cubic foot of gas consumed from that given by the Union-jet burner consuming 5 cubic feet per hour, at 0.5 inch pressure. At this stage Mr. Gardner directed the attention of the members to a table in which were embodied the results of a series of tests made by Mr. Terrace, with the view to ascertain the loss of light with small burners and high pressure; also to a table showing the loss of light resulting from using different kinds of shades. He stated that if the extremes of the two tables were taken together the loss of light was something like 91 per cent.

In summing up, the author said he found from the different authorities that highly heated air produces complete combustion, and gives an

Proceeding, the author stated that the tests were taken horizontally and in the most favorable conditions for the open flame, viz., with a No. 8 burner consuming 5 cubic feet of gas per hour at 0.5-inch pressure. Comparing the covered globe with the open flame, an increase of light was obtained of from 10.36 to 21.56 per cent. Then, comparing the covered with the uncovered shades, a greater difference was arrived at, viz., 17.12 to 41.11 per cent. Blackened covers were tried in order to see if the increased luminosity was due to reflection; but they also showed the same good results. Tests were made at an angle of 45°, which is about the usual position of a light in relation to the person using it, and they gave, with a covered shade and a No. 8 burner, 53.76 per cent. more light than the open flame; whereas on comparing the light from the covered shade with that from the uncovered shade, 72.70 per cent. more light was obtained. With a No. 4 burner the increase of light, by using a covered shade, rose to as much as 120.5 per cent.

In conclusion, Mr. Gardner said that looking at the immense daily waste of gas (amounting, according to the late Dr. Wallace, to £130,000 per annum for Glasgow alone, fifteen years ago), he thought it would be well for the Glasgow Corporation Gas Trust to lead the way in promoting its economical consumption by instituting a Lighting Department that would superintend the burning of the gas, and not allow the consumers to waste so large a percentage of it.

There was very little time allowable for the discussion of the subject raised by Mr. Gardner's paper: but, as Mr. Foulis was present, he was called upon by the Chairman to make a few remarks. This gentleman said he had been much interested in the invention, the results of the testing of which had greatly surprised him. The gas authorities of the city and himself were always ready to encourage every feasible attempt to improve the illuminating effect of the gas supplied to the consumers, and in this spirit he had authorized Mr. Terrace and his assistant (Mr. Duncan) to test Mr. Gardner's invention most thoroughly. The results were seen both in the table exhibited and in the lamps with which Mr. Gardner had been experimenting that evening. He (Mr. Foulis) was not, however, yet prepared to admit that the whole of the effect, if even any appreciable amount of it, was obtained by the increased heat of the air used in the combustion of the gas. He rather thought it was almost wholly due to the quietness of the atmosphere within the shade. Having alluded to the experimental investigations which Mr. John Methven

had lately been conducting in a somewhat similar direction, but with Argand burners and the use of chimneys necessary for them, he remarked that he had been deeply interested in Mr. Gardner's paper and the experiments, and felt that the Society was much indebted to him for having brought the subject before them.

ITEMS OF INTEREST FROM VARIOUS LOCALITIES.

THE following plain, common-sense letter is well worth reading :

POUGHKEEPSIE GAS LT. COMPANY,
POUGHKEEPSIE, N. Y., Jan. 13, 1890. }

To the Editor AMERICAN GAS LIGHT JOURNAL :—I wish to thank you in behalf of our Company for the stand you have taken in regard to the general adoption by gas companies of the business of supplying electric currents. We have, I suppose, the very best facilities, from the peculiarities of our present position, for engaging in the production of what has been called the light of the future. We have a gas plant lying idle in the center of the city, with the privilege of paying a good round tax yearly on the same. We are often told by the venders of patented electric light apparatus that we are the only ones who could supply at a profit in Poughkeepsie this light of the future. Estimates have been received by us, and we have also figured on the prices received by the electric company doing business in our city, and the result is that we prefer to pay taxes on idle plant ; for experience has taught us that if we put half the capital and energy into our present business that would have to be employed did we determine to engage in electric lighting, our stockholders would be quite satisfied over the net result. Let me here state what we have been taught by our competitor in the business of supplying light. First, we find that, as a rule, where they succeed in securing a contract to light up a building the gas burners in that building were in bad condition. They make an impression on the mind of the user at once—he had poor gas burners and an inferior light ; the change to new incandescent lamps undoubtedly gives him a more satisfactory illumination. Naturally, his next door neighbor is called in, and the advertisement is secured. In fact, our electricians employ a man whose duty it is to ferret out places in which inferior gas burners are employed. In olden days, I must confess, we never thought of such a thing as looking after the state and condition of gas burners ; we let the consumer study the matter out for himself. But electricity and its advocates have taught us a good lesson, and brought us to the practice of doing that which in justice to our business was essential, provided we desired to give it that standing rightfully its own from inherent merit. We employ a man now to attend to all complaints, who is further instructed with the task of placing new burners where such are needed. The plan gives good satisfaction, for the burners are adjusted free of charge to the customers. We find this to be one of the best investments that we have ever made. The burner (made by the Jackson Burner Company, of your city) that we favor most is not expensive—it is an all steel burner and does not corrode. Of course, the Jackson article is for ordinary consumption in stores and dwellings ; for outdoor lights we use the Gordon lamp. We also use, in direct competition with the incandescent light, the albo-carbon, which, in my opinion, furnishes the cheapest illumination when the apparatus is properly cared for. But, Mr. Editor, permit me to impress on your mind that our field for gas supply is larger than that for illuminating purposes pure and simple ; and it is bound to widen when it can be shown that cooking by gas can be accomplished (at certain fairly remunerative figures) 25 per cent. cheaper than when dependence is placed upon the ordinary coal range. When you can afford to sell gas for such use at \$1 per 1,000 in the summer months, and all the time, why can you not keep your works going all the time at their full capacity? We started last May in the cooking business, and made the start with but little faith in our ultimate success as to the new enterprise ; but one season's struggle has demonstrated to our entire satisfaction that this year will be the twelvemonth of our greatest output, for the demand is greater than we ever expected it would be. We, however, did not secure this result and that trade by simply putting the cooking, heating and power rate at \$1 per 1,000. We had to experiment on the different kinds of stoves that were offered on the market, and when we found the specimen best adapted for our gas we not only placed them ourselves, but instructed the consumer how to use them to the best advantage, and after a half dozen had been placed we found no trouble in securing additional customers. What I would say, in conclusion, to my fellow gas men is this : If you have an opposition electric lighting company in your city all that you need do to hold your position is to put as much energy and capital into your gas business as they do into theirs. If, then, you do not earn double what they

do on the investment, all I have to say is that your gas plant is not up to standard.

Yours,
JOHN TRACY.

A LINE or two from Mr. James Ferrier, Superintendent of the Eufaula (Ala.) Gas, Electric Light and Power Company, says that both divisions of the Company's business are going along smoothly and satisfactorily. We imagine, however, that the last fall season must have been an anxious one with him, and a busy one withal. We incline to this view from the fact that between September 7th and October 29th a new bench of 3's was added to the gas plant, while the same period beheld the placing, complete, of a 50-light arc installation. Within two weeks from the arrival of the machinery the electric lamps were in service.

MR. J. FRED SEAMON, formerly Inspector of the City Gas Works, Wheeling, West Va., has been appointed Superintendent of the works of the Cumberland (Md.) Gas Light Company. The new appointee takes the place of Mr. C. A. Seay, who has acted as Superintendent of the Cumberland Company since 1854.

MR. JNO. CABOT, of this city, has returned from his protracted visit to Europe. He looks hale and hearty, and had a splendid time, but hereafter his P. O. address will be at the old station, 306 to 310 Eleventh avenue, N. Y. City.

MR. ADAM WEBER informs us that he has been awarded the following contracts:

- 24 benches of 6's for 14th st. station Consolidated Gas Light Co.
- 26 " " 42nd st. " " " " "
- 20 " " Equitable Gas Company, N. York City.

These benches are to be fired with the new and improved Weber recuperative furnace.

SOME days ago the Union Depot, Birmingham, Ala., was thrown into confusion because of an incipient conflagration that occurred thus wise: In the dining-room of the depot both gas and electricity are used for lighting, and the electric wires are trailed along the service pipes of the chandeliers. A defective bit of insulation permitted contact of the current wire and the gas pipe, whereupon the latter was burned through, permitting the gas to escape. On the ignition of the gas the wooden ceiling took fire. The flames, however, were extinguished before they had gained any headway.

THE bids recently opened by City Works Commissioner for the public lighting of Brooklyn, N. Y., for the ensuing year, show no change over those submitted in 1889 save in respect to the rate asked by the Brooklyn Gas Light Company. The proposals are as follows :

Bidder.	Rate per Light.
Citizens Electric Light Company.....	\$182.50
Municipal " " "	182.50
Brooklyn Gas Light Company.....	22.00*
Peoples " " "	22.00
Nassau " " "	22.00
Citizens " " "	22.00
Williamsburgh " "	21.75

The electric lighting specifications call for 1,200-candle power arcs (they have been " calling " for that illuminating value for some time back, but it is notorious that their real power does not exceed 400 candles) and 4,000 hours of burning. The gas lamps are equipped with 3-foot burners, and are lighted on an average of 4,000 hours per annum. The bid prices include lighting and extinguishing charges.

THE Brooklyn companies also agreed to supply gas to the public buildings at the uniform rate of \$1.60 per 1,000—which, by-the-way, is the maximum rate that may be charged for gas within the city limits.

WE understand that the Suburban Light and Power Company has been notified by the Mayor that its offer for lighting Boston has been accepted. The terms of the contract for the city proper, South Boston, Dorchester and West Roxbury are 39.74 cents per arc per night, the rate for the Roxbury district to be 39.99 cents. There are about 900 lamps in the allotment, and it is estimated that under the agreement Boston will save something like \$72,000 over the total sum paid out on like account last year. The new Company—it is at present without sufficient plant facilities to carry out the work—has pledged itself to be ready to light

*Last year, \$19.80.

both Roxburys and Dorchester within six weeks, South Boston within 12 weeks and Boston proper within 16 weeks. In the meantime, the Boston Electric Light Company (which performed the lighting for 1887) will keep on the service until the successful bidders are ready to take up the task.

No doubt the Boston authorities are satisfied that the Suburban Light and Power Company is solvent and amply able to perform all its promises; but in view of the very low figures that it has seen fit to accept (and presuming that the requirements as to candle power and service are to be looked after critically by the Superintendent of lamps), we nevertheless are under the impression that many a strain will be made during the life of the contract, on even what is known as the French style of measurement, by the Company. Lamps of the illuminating value required by the specifications cannot be supplied at a profit in Boston at the accepted contract figures.

THE proprietors of the Troy (N. Y.) Gas Company have placed on Second street, between Broadway and Congress street, ten Gordon lamps, with a view to making a determination whether such lamps can be depended upon with certainty for public lighting. The New York samples, it might be added, are answering every requirement.

MR. JNO. MACKEOT, Supt. of the West End Gas Works (Main street, Pittsburgh, Pa.), was the victim of a painful accident some days ago. While overlooking repairs to an oil tank, an explosion occurred that scattered the burning oil over the Superintendent's face and neck.

ABOUT a fortnight ago the City Council of Monterey, Mexico, granted a franchise for the operation of a gas and water works at that point to Messrs. B. F. Larue, G. S. Butcher and Blas D. Guiterrez. The concession is a good one, and the gentlemen named are perfectly solvent. This place is the capital of Nuevo Leon, Mexico, is on the river San Catalina at a point about 175 miles south of Laredo, Tex., and is in the heart of a very fertile valley. Population about 28,000.

THE proprietors of the St. Croix (Me.) Gas Company are inclined to add an incandescent plant to their present arc installation.

SUPT. DOUGLAS, of the Mutual Gas Light Company, Savannah, Ga., is busily engaged in making important extensions to the Company's distributing system. About two miles of 4-inch pipe will be placed, and we have an idea that it will prove to be about as good an investment as the Company ever made.

A CORRESPONDENT informs us that the General Statutes of the State of Ohio contain the following provision: "The Council of any corporation in which gas works may be constructed, may provide by ordinance for the appointment of an inspector of gas, whose duty it shall be to inspect all gas and gas meters, and certify the correctness of all bills against consumers, make photometric tests, and perform such other duties as may be prescribed."

SENATOR BUTLER has offered a resolution in the Senate directing the Committee on the District of Columbia to inquire into the expediency of the purchase by the government, by condemnation or otherwise, of the works of the Washington Gas Light Company, and to inquire what would be a reasonable profit on the capital stock of said Company, and what dividends have been paid in the past 10 years on the stock. The Committee is directed to report their investigations to the Senate. Have we not been treated already to a nauseating plethora of farcical investigations into the gas supply of Washington that originated in the "Upper House?"

THE authorities of Philadelphia are figuring on what the probable cost of introducing the eight hour labor system in the city would amount to. Their investigations so far point to the fact that in the Bureau of Gas the extra amount of cash required per annum would be \$255,360.

THE electric plant of the Rockville (Conn.) Gas Company has been completed. It is said to be quite satisfactory to the proprietors.

THE Chairman of the Finance Committee of Cincinnati Councils has reported an ordinance under which it is proposed to create the position of Electrical Engineer, the appointment to be made by the Mayor, subject to approval by the Council. The term of office is to be for two

years, the salary \$2,500 per annum, and the bond to be \$5,000. Further, that the sum of \$1,000 shall be appropriated annually to the Cincinnati University for the use of scientific apparatus for testing electric apparatus for light and power, and "artificial illumination of every kind."

THE City Council, of Columbus, Ga., having determined that the city was not being properly lighted under the arc contract now in force, has decreed that hereafter, within certain defined limits, there shall be only 600 feet between arcs.

ABOUT a fortnight ago Mayor Davidson, of Baltimore, forwarded to Capt. Hall, President of the Consolidated Gas Company, the following letter: "So much has been said and written in regard to what may be called the Armstrong proposition, and some of its features are so interesting that it is well worth considering. That the supply of gas is in the nature of a natural monopoly, and that the time has arrived when cities must derive some portion of the revenue to meet their necessarily enormous and increasing expenses from such monopolies may be conceded. The question then presents itself as to the certainty and amount of the city's revenue according to the proposition offered. If Mr. Armstrong's figures and estimates could be guaranteed the proposal would be very inviting, but as they are merely conjectured, I would suggest something more definite and certain. For instance, let the Gas Company (1) waive its claim to any exemption of its plant from taxation; (2) to agree to supply the city with gas at, say, \$1 per 1,000; (3) pay the city as a bonus, say, \$10,000 during 1890, and increase the same \$10,000 during each year for 25 years, such bonus to be considered as part of the expenses of the Company in ascertaining the profits to be paid to the city; (4) the city to reserve the right to abrogate the agreement at the expiration of any period of 5 years, upon giving, say, one year's notice to that effect. In this shape the city would derive immediate advantage from the arrangement though small in proportion to the enhancement in value of the Company's stock immediately upon the adoption of the measure, and at the same time the gas consumer will pay no higher rate than he will probably be compelled to pay for some years without such a measure." Mayor Davidson's cool assurance, say, for solidity, is little short of remarkable; and so it also seemed to strike the gentleman who was favored with the communication. On the day following the reception of the letter Capt. Hall sent the following reply: "We are in receipt of your letter. It has been read to the committee, and it is their unanimous opinion that the proposition is so onerous that it is impossible to accede to it under any circumstances."

THE following is the result of the recent election held by the Laclede Gas Light Company, shortly after the purchase by the latter of the old St. Louis Gas Light Company's franchises and property: President, Emerson McMillin; Vice-President and Purchasing Agent, J. D. Thompson; Treasurer and Paymaster, George M. Paschall; Secretary and General Bookkeeper, Alex. Ross; Engineer, Frederic Egner; Supt. Station "A," John B. Taylor; Supt. Station "B," Geo. C. Brown; Supt. Stations "C" and "D," Geo. T. Thompson—and a decidedly efficient staff it seems to us to be. It is the intention of the management to expend about \$500,000 in remodeling the works of the old St. Louis Gas Light Company at Second and Convent streets, and to use them as the main station of the Company, to be known as station A. Station B is the works of the Laclede Company, on Main and Howard streets. Station C is to include the two gasholders at 14th and Gratiot streets, and station D includes the new holder at Evans avenue and Sarah street.

MR. JAMES HOOPER, who had been Superintendent of the Media (Pa.) gas works for a number of years, has been incapacitated for duty because of ill-health.

SOME time ago we noted the incorporation of the Plattsburgh (N. Y.) Light, Heat and Power Company, which was formed for the purpose of consolidating the present gas and electric light interests of the place. The gas interest predominates in the amalgamation. It is probable that the gas plant will be transferred to the electric lighting station.

IT is estimated that an expenditure of \$200,000 will be made this year by the Gas Bureau of Philadelphia in main extensions.

IN 1852 the San Francisco (Cal.) Gas Light Company charged \$15 per thousand cubic feet for gas; now the ruling rate is \$2. During the past year a marked increase took place in the use of gas for purposes other than lighting.

AMONG the matters to be considered at the coming annual election at the stockholders of the Edison Electric Illuminating Company, of this city, will be a proposition to increase the capital stock from \$2,500,000 to \$4,500,000; also, to create a mortgage to secure a series of bonds on the present "and certain future property of the Company." The meeting will be held on the 28th inst.

SOME complaint has been made of late in Philadelphia about the poor quality of the gas that is being supplied to consumers, which is in direct conflict with the daily reports made at the works. These latter determinations go to prove that the quality of the Quaker City gas was never better than now. It is likely, however, that those who complain are consuming gas through undersized services and imperfect burners. Another reason, perhaps, and a good one, too, is that the main system in several districts of the city is all too small for the drafts that are being made upon it.

THE ordinance introduced in the St. Louis House of Delegates by Mr. Stone, under which it is proposed to regulate gas rates in the city, is as follows: "For a period of five years from and after the passage of this ordinance the price of illuminating gas in the city of St. Louis to consumers shall not exceed 90 cents per 1,000 cubic feet on all bills paid within 5 days after the presentation thereof, and 95 cents per 1,000 cubic feet on all bills paid after the expiration of 5 days from presentation, and for said period of years in said city the price of gas sold to consumers to be used for fuel and power purposes shall not exceed 45 cents per 1,000 cubic feet on all bills paid within 5 days after presentation, and 50 cents per 1,000 cubic feet on all bills paid after the expiration of 5 days from presentation." The Stone measure evoked a lively discussion, which terminated in its indorsement by the House. The ordinance now goes to the Council for concurrence. Mr. Stone, in arguing in support of his pet project, admitted that it was very uncertain whether the price of gas could be so fixed, but he thought it would be well to pass the ordinance, and then permit the courts to define it. Mr. Stone could give Dogberry points.

SENATOR HAYS has introduced to the notice of the Kentucky Senate an Act to amend the charter of the Louisville Gas Company, empowering the latter to supply electric currents. The City Council of Louisville recommends the adoption of the Act.

As the result of a recent shipment of Breckenridge cannel, by Messrs. Perkins & Co., of this city, to Rio de Janeiro, that firm has just contracted with the Gas Company at that port for the delivery of 5,000 tons of Breckenridge during the next six months. Messrs. Perkins & Co. have chartered a vessel which will clear from Newport News next month with the first installment (1,600 tons) on account of the contract.

THE annual meeting of the American Society of Civil Engineers was held at the House of the Society on the 15th and 16th inst. The meeting was in every way successful.

JUDGE COLT, in United States Circuit Court, for the Massachusetts district concerned, recently heard argument in the case of the Lynn Gas Light Company vs. Aaron S. Higgins, et al. This was a libel in admiralty brought by the owners of the schooner Calvin P. Harris to recover compensation for damages sustained by that schooner in the channel leading to the dock of the Company, September 1, 1885, as the vessel was making her way to discharge a cargo of coal on the wharf of the Company. The damage to the schooner was caused by grounding on a bar that had formed across and in front of the dock, and which the libellants assert, in respect to its existence and dangerous state, should have been known to the respondents. The latter denied that the vessel was staunch and strong, and not only so, but that it was weak and unfit to carry the cargo on board. They also denied that they maintained the channel; neither did they require the Harris to pass through it. They did not know of the existence of any hard or dangerous bar at the point mentioned, and alleged, if the master of the vessel knew if any sand or earth had worked into the channel, that the respondents had no knowledge of such state of affairs. Further, that the damage was the result of the negligence and lack of skill of the parties in charge of the vessel. The District Court found damages amounting to \$4,750.

THE proprietors of the Galesburg (Ills.) Gas Light and Coke Company have issued the following notice: "As it has been our custom to reduce the price of gas about every three years, we now announce the following changes in the schedule: For gas consumed after April 1st,

1890, the price will be reduced from \$2.50 to \$2 per 1,000 cu. ft., with following discounts when 1,000 cu. ft. or over are consumed on one or each meter per month, providing the bill is paid on or before the 15th of each month:

Discount Rate.	Monthly Consumption.
20 cents per 1,000.....	1,000 to 3,000
40 " "	3,000 " 10,000
50 " "	10,000 and over,

making net rates of \$1.50, \$1.60 and \$1.80 per 1,000, which gives the people of Galesburg gas at a lower price than is customary in cities of this size. We make this price to induce a more general use, not only for light, but for cooking, heating, etc. It is our intention to offer great inducements to housekeepers to use gas stoves as soon as the season arrives."

THE amended fuel gas ordinances offered for consideration by Messrs. A. A. Woods and L. E. Lemaire to the New Orleans City Council have been indefinitely postponed.

AT the annual meeting of the Peoples Gas Light and Coke Company, of Cleveland, O., the following Directors were chosen: George H. Warming-ton, Chas. McNeill, M. A. Hanna, R. P. Rhodes and Belden Seymour, Jr.

THE Bloomfield (N. J.) Town Committee has awarded to the Montclair Gas and Water Company a contract for the public lighting. Under its terms the Company is to maintain a stated number of gas lamps (3-ft. burners), the same to be lighted every night until 1 A.M., at a charge of \$16 per lamp per annum.

MR. J. M. GLICK has been elected Secretary of the Girardville (Pa.) Gas Company.

AT the annual meeting of the stockholders of the White Plains (N. Y.) Gas Light Company, the following officers were elected: President, Samuel Conover; Vice-President, J. T. Chesborough; Treasurer, Samuel R. Pullen; Secretary, E. R. Phelps. The capital stock is to be increased to \$150,000, the increase to be devoted to plant enlargement.

THE Macomb (Ills.) Electric Light and Gas Company has been incorporated by Messrs. Chas. Ketteron, H. W. Cummings and J. N. Rume. Capitalized in \$25,000.

THE Poughkeepsie (N. Y.) Gas Light Company offers to perform the public lighting (on an all-night schedule) at the rate of \$20 per lamp per annum.

THE proprietors of the Herkimer (N. Y.) Gas Company announce a reduction in the sales rate to \$2 per 1,000 cubic feet.

MR. SIMON O. DALRYMPLE, who had been a Director in the Salem (Mass.) Gas Light Company for many years, died on the 12th inst.

Corrosion.

The *Locomotive* says that the purest water often is the most active in corroding and pitting plates, and this makes it probable that the active substance, in some cases at least, is air. It is well known that water is capable of dissolving a considerable amount of air; in fact, it is this dissolved air that enables fish to breathe. It is not so widely known, however, that the oxygen of the air is more soluble than the nitrogen. If a small quantity of water be shaken up in a bottle it dissolves some of the inclosed air, and when this is afterward driven off by boiling and analyzed, it is found to consist of oxygen and nitrogen in the proportion of 1 to 1.87, instead of 1 to 4, as in the natural air. Thus the dissolved air, being more than twice as rich in oxygen as common air is, and being brought into more intimate contact with the metal by means of the water that holds it in solution, exerts a correspondingly more noticeable effect.

It is probable, too, that water plays some other important action in connection with the oxidation of metals, for it has been found by recent experiments that pure oxygen will not combine with things that it has the greatest affinity for, provided it is perfectly dry. Even the metal sodium, which has an intense affinity for oxygen, may be heated in it to a very high temperature without combination, provided sufficient precautions are taken to exclude the slightest trace of moisture. It appears, therefore, that water plays a most important part in the oxidation of metals by air—a part, indeed, that we cannot explain, and that we really know but little about.

Advertisers Index.

GAS ENGINEERS.	
Jos. R. Thomas, New York City	92
Wm. Henry White, New York City	97
Wm. Mooney, New York City	92
William Gardner, Pittsburgh, Pa.	92
Fred. Bredel, N. Y. City	91
GAS AND WATER PIPES.	
Gloucester Iron Works, Phila., Pa.	92
Mellert Foundry and Machine Co., Reading, Pa. (John Fox, Selling Agent, N. Y.)	92
Ohio Pipe Co., Columbus, Ohio	92
M. J. Drummond, New York City	92
R. D. Wood & Co., Phila., Pa.	94
Warren Foundry & Machine Co., New York City	92
Donaldson Iron Co., Emaus, Pa.	92
Dennis Long & Company, Louisville, Ky.	92
A. & W. S. Carr Co., New York City	82
GAS WORKS APPARATUS AND CONSTRUCTION.	
James R. Floyd & Sons, New York City	95
Continental Iron Works, Greenpoint, L. I.	95
Delly & Fowler, Phila., Pa.	95
Kerr Murray Mfg. Co., Fort Wayne, Ind.	83
Stacey Mfg. Co., Cincinnati, Ohio	95
Bartlett, Hayward & Co., Baltimore, Md.	93
Morris, Tasker & Co., Limited, Phila., Pa.	93
Davis & Farnum Mfg. Co., Waltham, Mass.	83
R. D. Wood & Co., Phila., Pa.	94
Bouton Foundry Co., Chicago, Ills.	95
Smith & Sayre Manufacturing Co., New York City	95
Fred. Bredel, N. Y. City	91
United Gas Improvement Co., Phila., Pa.	85
Henry Pratt & Co., Chicago, Ill.	91
National Gas Light and Fuel Co., Chicago, Ills.	86
Simpkin & Hillyer, Richmond, Va.	81
PROCESSES.	
National Gas Light and Fuel Co., Chicago, Ills.	86
Bartlett, Hayward & Co., Baltimore, Md.	93
Wm. Henry White, N. Y. City	97
United Gas Improvement Co., Phila., Pa.	85
Henry Pratt & Co., Chicago, Ill.	91
INCLINED RETORTS.	
Laclede Fire Brick Manuf'g Co., St. Louis, Mo.	51
GASHOLDER TANKS.	
W. C. Whyte, New York City	86
J. P. Whittier, Brooklyn, N. Y.	81
GASHOLDER PAINT.	
The Government Waterproof Paint Co., Boston, Mass.	81
RETORTS AND FIREBRICK.	
J. H. Gautier & Co., Jersey City, N. J.	90
B. Kreisler & Sons, New York City	90
Adam Weher, New York City	90
Laclede Fire Brick Manuf'g Co., St. Louis, Mo.	90
Brooklyn Retort and Fire Brick Works, Brooklyn, N. Y.	90
Borgner & O'Brien, Phila., Pa.	90
James Gardner, Jr., Pittsburgh, Pa.	90
Henry Maurer & Son, New York City	91
Chicago Retort and Fire Brick Co., Chicago, Ills.	90
Baltimore Retort and Fire Brick Co., Baltimore	90
Oakhill Gas Retort and Fire Brick Co., St. Louis, Mo.	90
SCRUBBERS AND CONDENSERS.	
G. Shepard Page, New York City	52
R. D. Wood & Co., Phila., Pa.	94
REGENERATIVE FURNACES.	
Bartlett, Hayward & Co., Baltimore, Md.	93
Fred. Bredel, New York City	91
Chicago Retort and Firebrick Co., Chicago, Ills.	90
Wm. Henry White, N. Y. City	97
J. H. Gautier & Co., Jersey City, N. J.	91
GAS GOVERNORS.	
Connelly & Co., New York City	87
Fred. Bredel, N. Y. City	91
Friedrich Lux, London, England	80
SELF-SEALING MOUTHPIECE DOORS.	
Smith & Sayre Mfg. Co., New York City	91
TAR AND CARBONIC ACID EXTRACTOR.	
Geo. Shepard Page, N. Y. City	84
PURIFYING MACHINES.	
C. & W. Walker, London, England	18
CEMENTS.	
C. L. Gerould & Co., Brooklyn, N. Y.	90
GAS ENRICHERS.	
Standard Oil Co., Cleveland, Ohio	56

GAS METERS.

John J. Griffin & Co., Phila., Pa.	98
American Meter Co., New York and Philadelphia	99
The Goodwin Gas Stove and Meter Co., Philadelphia, Pa.	99
Helme & McIlhenny, Phila., Pa.	99
D. McDonald & Co. Albany, N. Y.	96
Nathaniel Tufts, Boston, Mass.	98
Maryland Meter and Manufacturing Co., Baltimore, Md.	98
John Hillen, Brooklyn, N. Y.	98

EXHAUSTERS.

P. H. & F. M. Roots, Connersville, Ind.	94
Smith & Sayre Manufacturing Co., New York City	95
Wilbraham Bros., Philadelphia, Pa.	87
Connelly & Co., New York City	87

GAS COALS.

Penn Gas Coal Co., Phila., Pa.	97
Perkins & Co., New York City	96
Newburgh Orrel Coal Co., Baltimore Md.	97
Despard Coal Co., Baltimore, Md.	97
Chesapeake and Ohio R. R. Coal Agency, N. Y. City.	97
Westmoreland Coal Company, Phila., Pa.	97
J. & W. Wood, New York City	96

CANNEL COALS.

Perkins & Co., New York City	96
J. & W. Wood, New York City	96

VALVES.

Ludlow Valve Manufacturing Co., Troy, N. Y.	83
John McLean, New York City	88
Chapman Valve Manufacturing Co., Boston, Mass.	88
R. D. Wood & Co., Phila., Pa.	94
A. & W. S. Carr Co., New York City	82

GAS ENGINES.

Schleicher, Schumm & Co., Phila., Pa.	68
Clerk Gas Engine Co., Phila., Pa.	88
Van Duzen Gas Engine Co., Cincinnati, Ohio	88

ENGINES AND BOILERS.

Jarvis Engineering Co., Boston, Mass.	87
Ball Engine Co., Erie, Pa.	81
Westinghouse Machine Co., Pittsburgh, Pa.	87

GAS LAMPS.

G. Shepard Page, New York City	88
Standard Gas Lamp Co., Phila., Pa.	81
Welshach Incandescent Gas Light Co., Phila., Pa.	82
The Siemens-Lungren Company, Philadelphia, Pa.	82

PURIFIER SCREENS.

John Cahot, New York City	88
Bartlett, Hayward & Co., Baltimore, Md.	88

GAS STOVES.

American Meter Co., New York and Philadelphia	89
The Goodwin Gas Stove and Meter Co., Phila. Pa.	100
George M. Clark & Company, Chicago, Ills.	82

STREET LAMPS.

J. G. Miner, Morrisania, New York City	49
Bartlett Street Lamp Man'g Co., New York City	81

BURNERS.

C. A. Gefroerer, Phila., Pa.	96
------------------------------	----

STEAM BLOWER FOR BURNING BREESE.

H. E. Parson, New York City	88
-----------------------------	----

PURIFYING MATERIAL.

Connelly & Co., New York City	87
Friedrich Lux, London, England	80
Edgewater Lime Works, Edgewater, N. J.	80

COKE CRUSHER.

C. M. Keller, Columbus, Ind.	97
------------------------------	----

ELECTRICAL APPARATUS.

Wm. Henry White, N. Y. City	97
-----------------------------	----

SOLVENTS.

Maas & Waldstein, New York City	81
---------------------------------	----

SITUATION WANTED

As Inspector in a Gas Works

By a man of many years' experience. Understands stove work, improved lamps, inspection of houses, meter proving, etc.

763-2 Address "CAPABLE," care this Journal.

FOR SALE.

A Complete Water Gas Plant. 60,000 Cu. Ft. Daily Capacity.

Fully equipped; all the latest improvements; includes Generator, Purifiers, and Holder. Can be removed to any part of the country, and set up at small cost. For further information apply to BRADFORD GAS LT. & HEATING CO., Dunkirk, N. Y.

FOR SALE,

One 5-ft. Station Meter.

One Hydraulic Main (five sections), wrought iron, 22 by 24, with Bye-Pass on Dip-Pipes.

25 Valves, Stand-Pipes, 7-inch Mouthpieces and Lids, all complete, ready for use, to fit up five benches of 5's.

This apparatus is all in first-class condition.

Price, \$800, f.o.b. cars or boat, Poughkeepsie, N. Y.

Inquiries may be sent to this Office.

GAS WORKS FOR SALE.

A CONTROLLING INTEREST IN SEVERAL

Interior California Coal Gas Plants,

now paying handsomely, are offered on very reasonable terms. This is an exceptionally good opportunity for practical gas men of limited means, wishing to remove to a mild and healthful climate, to acquire an established and paying business. Particulars given and full investigation solicited.

760-11 SECRETARY, 123 Beale Street, San Francisco, Cal.

Fuel and Its Applications.

By E. J. MILLS, D.Sc. F.R.S., and F. J. ROWAN, C.E., assisted by others, including Mr. F. P. Dewey, of the Smithsonian Inst., Wash., D. C.

7 PLATES, AND 607 OTHER ILLUSTRATIONS. ROYAL OCTAVO, PAGES XX, 802. HANDSOME CLOTH, \$7.50.

A. M. CALLENDER & CO., 42 Pine St., N. Y.

GEROULD'S

System Gas Bookkeeping.

Approved and adopted by many of the prominent Gas Engineers of the Country.

Sample Sheets and Price-List furnished free on application to

L. P. GEROULD, - - Mendota Ill.

EDGEWATER LIME WORKS

Chas. F. McKenna, Proprietor.

SHELL LIME.

Lime by the Cargo for Gas Purification.

EDGEWATER, BERGEN CO., N. J.

Write for Testimonials and Prices.

FRIEDRICH LUX,

Ludwigshafen am Rhein and London.

Lux Mass

GAS GOVERNORS,

Gas Balance.

6 PER CENT.
First Mortgage Bonds
ON GAS WORKS
 SITUATED IN GROWING WESTERN TOWNS.
Principal and Interest Guaranteed.
 INTEREST SEMI-ANNUALLY.
 For sale by the undersigned, who will furnish all necessary information regarding them.
JOS. R. THOMAS, 42 Pine St., N. Y. City.

PATENTS.
FRANKLIN H. HOUGH
 Solicitor of American & Foreign Patents.
 925 F. ST., WASHINGTON, D. C.
 (NEAR U. S. PATENT OFFICE.)

Personal attention given to the preparation and prosecution of applications for Letters Patent. All business before the U. S. Patent Office attended to for moderate fees. **No Agency in the United States possesses superior facilities for obtaining Patents,** or for ascertaining the patentability of inventions. Copies of patents furnished for 25 cents each. Correspondence solicited.

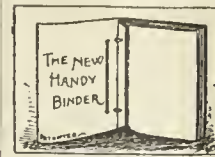
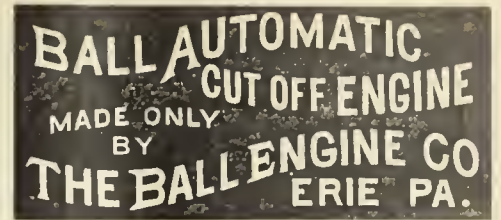

THE NEW HANDY BINDER.

This article may be described as elegant in appearance, strong, durable, and possessing many special qualities of its own. It allows the opening of the pages perfectly flat, whether one or several numbers are in the binder. Any number can be taken out and replaced without disturbing the others. The papers are not mutilated for subsequent binding in permanent form. The binder is supplied with gilt slide title, and is an ornament to any desk or reading table. The JOURNAL, filed in the Handy Binder, becomes a volume of great value, always convenient for instant reference. **Handy Binder, Postage paid, \$1.00.**

A. M. CALLENDER & CO., 42 Pine St., N. Y.

Simpkin & Hillyer
 RICHMOND, VA.
 MANUFACTURERS OF
Gas Works Apparatus
 BENCH CASTINGS, CONDENSERS,
 Scrubbers, Purifiers, Dry Center Seals,
FOUR-WAY VALVES, GAS VALVES,
 SULPHATE OF AMMONIA APPARATUS,
 TANKS, ENGINES, BOILERS,
 PUMPS, ETC., ETC.
 Plans, Specifications and Estimates furnished for new works, or alteration of old works. Correspondence solicited. Works, Newport News, Va.

Bartlett Street Lamp Mfg. Co.
 MANUFACTURERS OF
Globe Lamps,
 FOR
 Streets, Parks, Public Buildings, Railroad Stations, etc.
LAMP POSTS
A Specialty.
Office and Salesroom,
40 & 42 COLLEGE PLACE, - - N. Y. CITY.
 Gas Companies and others intending to erect Lamps and Posts will do well to communicate with us.

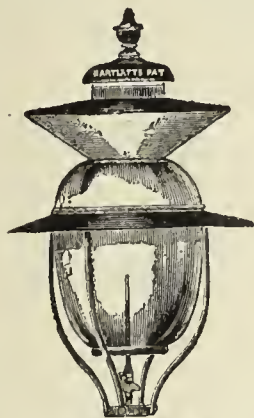

GAS vs. ELECTRIC LIGHT.

We would invite attention to the able and exhaustive argument of General A. Hickenlooper, President of the Cincinnati Gas Light and Coke Company, contained in a handsome pamphlet of 96 pages, entitled

"EDISON'S INCANDESCENT ELECTRIC LIGHTS FOR STREET ILLUMINATION. REPORT OF AN ARGUMENT DELIVERED BY A. HICKENLOOPER BEFORE THE COMMITTEE ON LIGHT, MUNICIPAL COUNCIL, CITY OF CINCINNATI, JULY 22, 1886."

This is a subject of special interest to all Gas Light Companies.

Prices.		
25 copies.....	\$7.50	100 copies..... \$22.50
50 copies.....	12.50	250 copies..... 50.00

A sample copy will be sent by mail on receipt of 50 cts.
A. M. CALLENDER & CO., 42 PINE ST., N. Y. CITY



PHILADELPHIA. NEW YORK. CHICAGO.
 STEPHEN A. MORSE, President. EDWIN F. MORSE, Secretary.
 GODFREY REBMANN, Vice-Pres. CARLTON M. WILLIAMS, Treas.
STANDARD GAS LAMP CO.,
 Main Office, 411 Cherry St. Factory, 1101, 1103, 1105 Frankford Av.
PHILADELPHIA, PA.

It is to the interest of Gas Companies and Cities to double the efficiency of the light on streets by using Dyott's Patent "CHAMPION" LAMPS. They save 50 per cent. over others in cost of repairs, are ornamental, and indestructible except by violence.
 Our Patent System of Instantaneously Lighting Gas (without electricity), for Railroad Depots is unequalled.
 Dyott's High Candle Power Burner is a very superior lamp where a concentrated and brilliant light is wanted in Hotels, Stores, Depots, etc.
 Special Drawings furnished and Estimates cheerfully given, either from Architects, Engineers, or our Draughtmen's Plans.
 We manufacture every description of Plain and Ornamental Lamps, Posts, Brackets, Clusters, etc. Correspondence solicited.

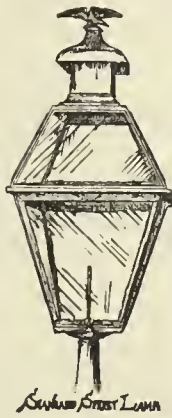

GASHOLDER PAINT.
 Use Only
THE GOVERNMENT WATERPROOF PAINT.
 Proof against Ammonia, and Absolutely Waterproof. Send for Prices and Particulars.
THE GOVERNMENT WATERPROOF PAINT CO., 122 Milk Street, Boston, Mass.

GREENOUGH'S
"DIGEST OF GAS LAW."
 Price, \$5.00.

This is a valuable and important work, a copy of which should be in the possession of every gas company in the country, whether large or small. As a book of reference it will be found invaluable. It is the only work of the kind which has ever been published in this country, and is most complete. Handsomely bound. Orders may be sent to

A. M. CALLENDER & CO.,
 42 Pine Street, N. Y.

(Patented.) **IMPORTANT!** (Patented)
NEW SOLVENT FOR GAS PIPE DEPOSITS.
 Economical and Effective.
MAAS & WALDSTEIN, 44 Trinity Place and 81 Greenwich St., N. Y.

Gasholder Tanks & Gas Works Masonry Complete.
 PLANS PREPARED AND ESTIMATES FURNISHED AT SHORT NOTICE.
J. P. WHITTIER, - - 499 Wythe Av., Brooklyn, N. Y.

The Gordon Portico Lamp.

A successful Competitor of the Arc Electric Light for lighting Store Fronts, Show Windows, Depots, Railway Sheds, etc., etc.

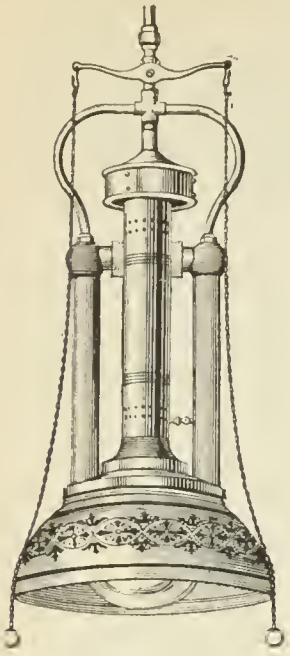

Gordon Portico Lamp.

The Gordon Street Lamp.

A Successful Competitor of the Arc Electric Light for lighting Streets, etc., etc.

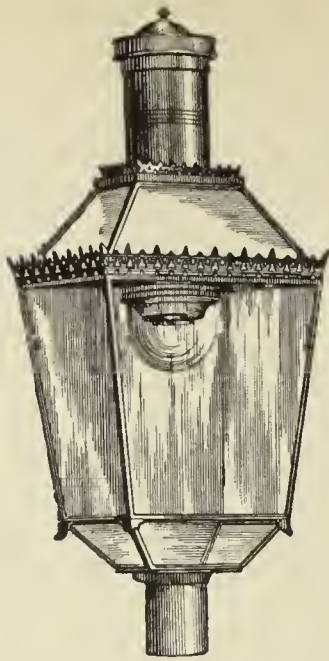

Gordon Street Lamp.

The Lungren Lamp.

A Successful Competitor of the Incandescent Electric Light for Interiors, etc. Is especially applicable for the lighting of Offices, Stores, Factories, Mills, Show Windows, Libraries, and all situations where an increased illumination is desired.

More than 25,000 Lungren Lamps are now in use. Testimonials, references, or any desired information will be cheerfully given.



Lungren Lamp.

THE SIEMENS-LUNGREN CO., N.E. Cor. 21st St. & Washington Av., PHILADELPHIA.

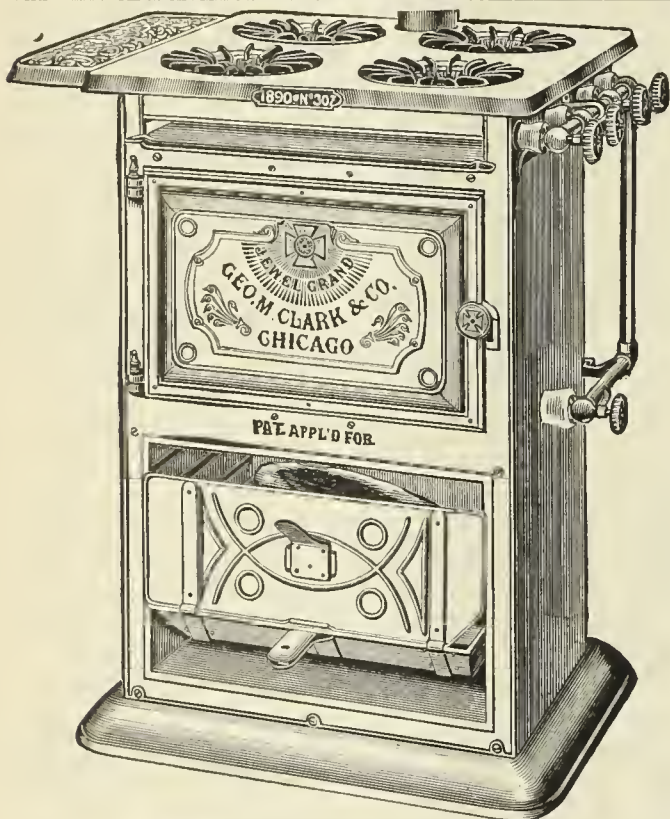

JEWEL GAS STOVES

MANUFACTURED BY

GEORGE M. CLARK & COMPANY,

Nos. 157 & 159 Superior Street, - - - Chicago, Ill.

EVERY CONCEIVABLE SIZE AND STYLE,

Ranging in Prices from \$1.50 to \$30.00.

WE USE NO GAS COCKS.

All Flames are Regulated by a Direct Needle Valve.

The JEWEL

IS THE

Only Well-Made Gas Stove on the Market.

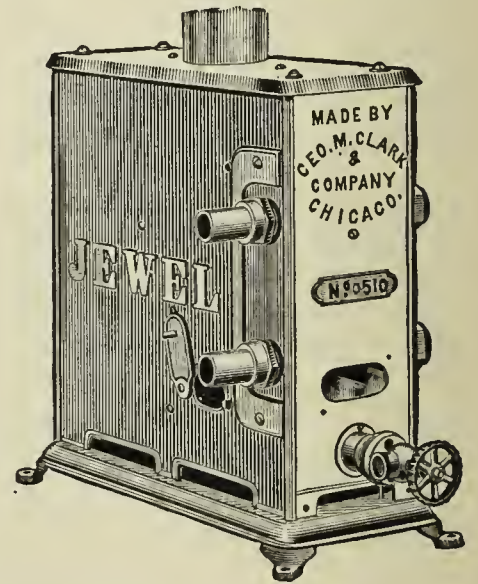

Write for our 1890 Catalogue and see for yourself.

A. & W. S. CARR CO. IRON PIPE, VALVES, 38 CENTRE ST. AND 140 NEW YORK. GATES, FITTINGS, PLUMBERS SUPPLIES.

WELSBACH SYSTEM

OF

Incandescent Gas Lighting.

OFFICE, DREXEL BUILDING, PHILA., PA.

At the Fall Session of the Board of Supervisors of Winnebago County, held at the County Court House, Oshkosh, Wis., Nov. 26, 1889, the report submitted by Mr. C. W. Cook, Chairman of the Committee on Public Buildings, recommending the use of the Welsbach Incandescent Gas Burner in the Buildings under their charge, was unanimously adopted, because of the extreme economy in the consumption of Gas and the superior character of the light obtained.

THIS SPACE
WILL BE
Occupied Next Month by the
KERR MURRAY MFG. CO.
FORT WAYNE, IND.
**GAS WORKS
APPARATUS
AND
HOLDERS.**

F. J. DAVIS & J. R. FARNUM,
TRUSTEES AND AGENTS FOR THE
SINUOUS FRICTION CONDENSER.

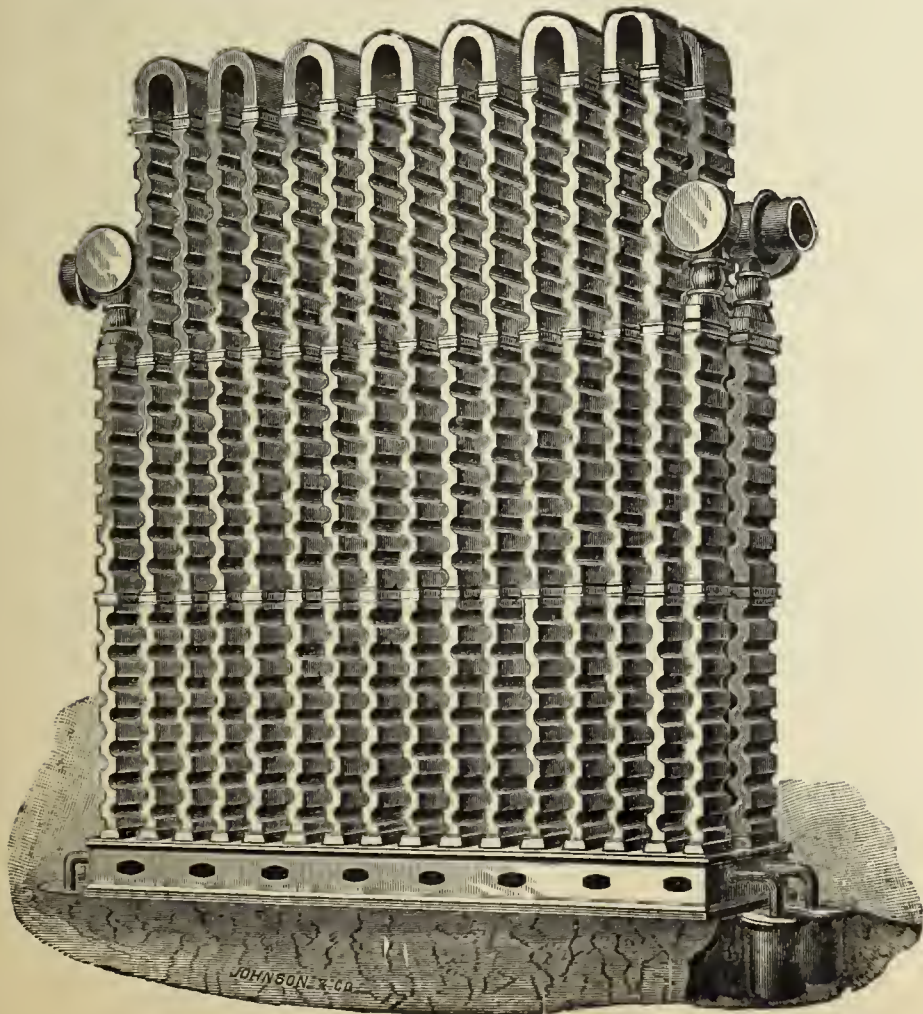

We desire to draw the attention of the gas community to the merits of the SINUOUS FRICTION CONDENSER. Companies intending to introduce new condensers into their works will do well to confer with us and examine plans and estimates before contracting for any other pattern. The FRICTION CONDENSER is now in use at the gas works located in the following places:

- | | | | |
|--------------------------------|------------------|-------------------------------|--------------------|
| Portland, Me. | Brookline, Mass. | Pawtucket, R. I. | Fredrickton, N. B. |
| Newport, R. I. | Chelsea, Mass. | Jamaica Plain, Mass. | St. John, N. B. |
| Gloucester, Mass. | Woburn, Mass. | Attleboro, Mass. | Paterson, N. J. |
| Newton & Water-
town, Mass. | Peoria, Ill. | Calais, Me. | Dover, N. H. |
| | Clinton, Mass. | Fall River, Mass. | Waltham, Mass. |
| | | Nassau Works, Brooklyn, N. Y. | |

DAVIS & FARNUM MFG. CO.

MANUFACTURERS OF

Gas and Water Pipes,

AND

GAS AND WATER MACHINERY

OF THE MOST APPROVED PATTERN.

Also, Gasholders and Iron Roofing.

Orders from Gas and Water Companies promptly attended to

WALTHAM, MASS.

Office, Room 55, Mason Building, 70 Kilby Street, Boston

THE WALKER TAR AND CARBONIC ACID EXTRACTOR.

A very general demand exists, in both large and small Gas Works, for an apparatus that will be absolutely efficient in the removal of the tar which passes the hydraulic main and condenser. Many attempts have been made to accomplish this, but, I believe, without success, until the introduction, five years ago, in England, of the C. & W. Walker Patent Tar and Carbonic Acid Extractor. During these years this apparatus has been adopted by many of the most prominent Engineers, not only in England, but also on the Continent of Europe and in other parts of the world. It is only necessary to give here a partial list in order to convince any intelligent American Gas Engineer that this machine must have succeeded fully in accomplishing the desired results.

The following Engineers have personally given permission to refer to them:

G. C. Trewby, Esq., Engineer-in-Chief of the Gas Light and Coke Co., London. The manufacturing plant at Beckton is built in complete sections of 3,000,000 cubic feet capacity each. A Walker Tar Extractor has been fitted to each one of these sections. This was done after a long and thorough trial on one of its sections. The Tar Extractor has been supplied to other works of the Gas Light and Coke Co., including those of which John Methven, Engineer of the Gas Light and Coke Co. at the Nine Elms Station, is in charge. Also to G. E. Stevenson, Peterborough Gas Works; B. Green, Mitcham and Wimbledon Gas Works; W. H. Smith, Bedford Gas Works; F. Linging, Norwich Gas Works; J. T. Browning, Colchester Gas Works; S. B. Darwin, Portsmouth Gas Works; J. McCrae, Dundee Gas Works; W. J. Wells, Stamford Gas Works; J. M. Darwin, Longton Gas Works; J. Paterson, Warrington Gas Works; and J. Coulter, of the Dundalk Gas Works. All of the foregoing gas works are located in Great Britain.

Mr. Charles A. Gerdenier, Superintendent of the Bridgeport (Conn.) Gas Light Company, writes as follows, under date of Dec. 3, 1887:

"The C. & W. Walker Tar and Carbonic Acid Extractor has been in operation at these works for the past six weeks, and is an unqualified success. It removes every particle of Tar from the gas in once passing through the apparatus, and a large percentage of the Carbonic Acid. I also feel quite sure that it prevents the formation and deposit of Naphthaline, because since I started the Washer I have had no stoppages from this cause. These works have been seriously troubled with Tar for many years, and I have used several kinds of apparatus and every expedient which has come to my attention for dealing with the difficulty, but without success. The Walker apparatus occupies comparatively small space, is less expensive than other systems, and requires but little attention. I carry 2½-inch seal, and have an automatic tar delivery valve. This Tar Extractor is indispensable to gas makers."

I have taken the Agency for the United States for this apparatus, and am now prepared to make contracts to erect it on the premises of any Gas Company. It would be manufactured in the following sizes:

No. 1,	50,000 to	100,000	cu. ft. per 24 hrs.,	3	ft. square,	5	ft. deep.
No. 2,	"	"	"	4	"	"	"
No. 3,	"	"	"	5	"	"	"
No. 4,	"	"	"	6	"	"	"
No. 5,	"	"	"	7	"	"	"
No. 6,	"	"	"	8	"	"	"
No. 7,	"	"	"	9	"	"	"
No. 8,	"	"	"	10	"	"	"
No. 9,	"	"	"	12	"	"	"
No. 10,	"	"	"	15	"	"	"

This Tar Extractor will perform its work with about one-fourth the usual back-pressure heretofore required. It is simple in construction, and can be supplied at a very reasonable price—less than any other ever before introduced. Satisfactory results will be guaranteed in every instance.

GEO. SHEPARD PAGE,

SOLE AGENT FOR THE UNITED STATES,

No. 69 Wall Street, - - - New York

THE UNITED GAS IMPROVEMENT CO.

DREXEL BUILDING, PHILADELPHIA.

OFFICERS:

WILLIAM W. GIBBS, President.

GEORGE PHILLER, Vice-President.

SAM'L T. BODINE, Gen'l Manager.

RANDAL MORGAN, Gen'l Counsel.

EDWARD C. LEE, Sec'y and Treas.

ALEX. C. HUMPHREYS, Gen'l Supt.

WALTON CLARK, Ass't Gen'l Supt.

H. H. EDGERTON, Chem. and Eng'r.

DIRECTORS:

GEORGE PHILLER,

THOMAS DOLAN

HENRY C. GIBSON,

WM. T. CARTER,

WILLIAM G. WARDEN,

SAM'L T. BODINE.

BUILDERS, LESSEES AND PURCHASERS OF

➤ GAS WORKS. ✦

Orders solicited from Large Cities, Small Towns, Mills, Institutions, from all who want more Light for Less Money.

NATIONAL GAS LIGHT AND FUEL COMPANY,

No. 218 La Salle Street, Chicago.

THE SPRINGER SYSTEM

OF

Fuel and Illuminating Water Gas Works.

REFERENCES.

People's Gas Lt. & Coke Co..Chicago, Ill.
 Illinois Light, Heat & Power
 Co.....Chicago, Ill
 Elgin National Watch Co...Elgin, Ill.
 C. R. I. & P. R. R. Shops..Chicago, Ill.
 Decatur Gas Lt & Coke Co..Decatur, Ill.
 Niles Gas Light Co.....Niles, Mich.
 Newton Illuminating Co...Newton, Kansas.
 Wellington Light & Heat Co..Wellington, Kansas.
 Chippewa Falls Gas Lt. Co..Chippewa Falls, Wis.
 Elkhart Gas Lt & Coke Co..Elkhart, Ind.
 Madison City Gas Light Co.Madison, Wis.
 South Bend Gas Light Co..South Bend, Ind.
 Sheboygan National Gas Co.Sheboygan, Wis.
 Salina Gas Light Co.....Salina, Kansas.
 The Rathbun Co.....Deseronto, Prov.Ont.
 Jefferson City Gas Lt. Co..Jefferson City, Mo.
 Mankato Gas Light Co.....Mankato, Minn.
 Lima Gas Light Co..Lima, Ohio.

Minneapolis Gas Light and
 Coke Co.....Minneapolis, Minn.
 Bellevue Water and Fuel }
 Gas Light Co..... } Bellevue, Campbell
 } County, Ky.
 Bucyrus Gas Lt. & Fuel Co.Bucyrus, Ohio.
 Morris Gas Co.....Morris, Ill.
 Los Angeles Gas Co.....Los Angeles, Cal.
 San Diego Gas Fuel & Elec-
 tric Lt. Co.....San Diego, Cal.
 Sioux Falls Gas Co.....Sioux Falls, Dak.
 Dakota Gas and Fuel Co..Grand Forks, Dak.
 St. Johns Mutual Gas Co...St. Johns, Mich.
 Stillwater Gas Light Co...Stillwater, Minn.
 St. Paul Gas Light Co.....St. Paul, Minn.
 Emporia Electric and Gas
 Light Co.....Emporia, Kas.
 Van Wert Gas Light Co...Van Wert, Ohio.
 Lansing Gas Light Co.....Lansing, Mich.
 San Francisco Gas Lt. Co...San Francisco, Cal.

Shelbyville Gas Light Co...Shelbyville, Ind.
 Great Falls Gas Light Co..Great Falls, N. H.
 Belleville Gas Co.....Belleville, Ontario
 Rochester Lt. and Fuel Co..Rochester, Minn.
 Northwestern Gas Light and
 Coke Co.....Evanston, Ill.
 Lincoln Gas Light Co.....Lincoln, Neb.
 Davenport Gas Light Co...Davenport, Iowa.
 Municipal Gas Co.....Albany, N. Y.
 Alliance Gas Light Co.....Alliance, Ohio.
 New Gas Light Co.....Janesville, Wis.
 *Chicago Gas Light & Coke
 Co.....Chicago, Ill.
 *Joliet Gas Co.....Joliet, Ills.
 *Superior Light & Fuel Co.Superior, Wis.
 *Kewanee Gas Light Co...Kewanee, Ill.
 *Standard Gas Light Co...New York City.

* Building.

GUARANTEED ESTIMATES of Cost of Gas Furnished on Application.

GASHOLDER TANK CONSTRUCTION, ETC.

Gas Companies and others about to erect Gasholders will find it profitable to consult
 W. C. Whyte, who for over 30 years has made a specialty of

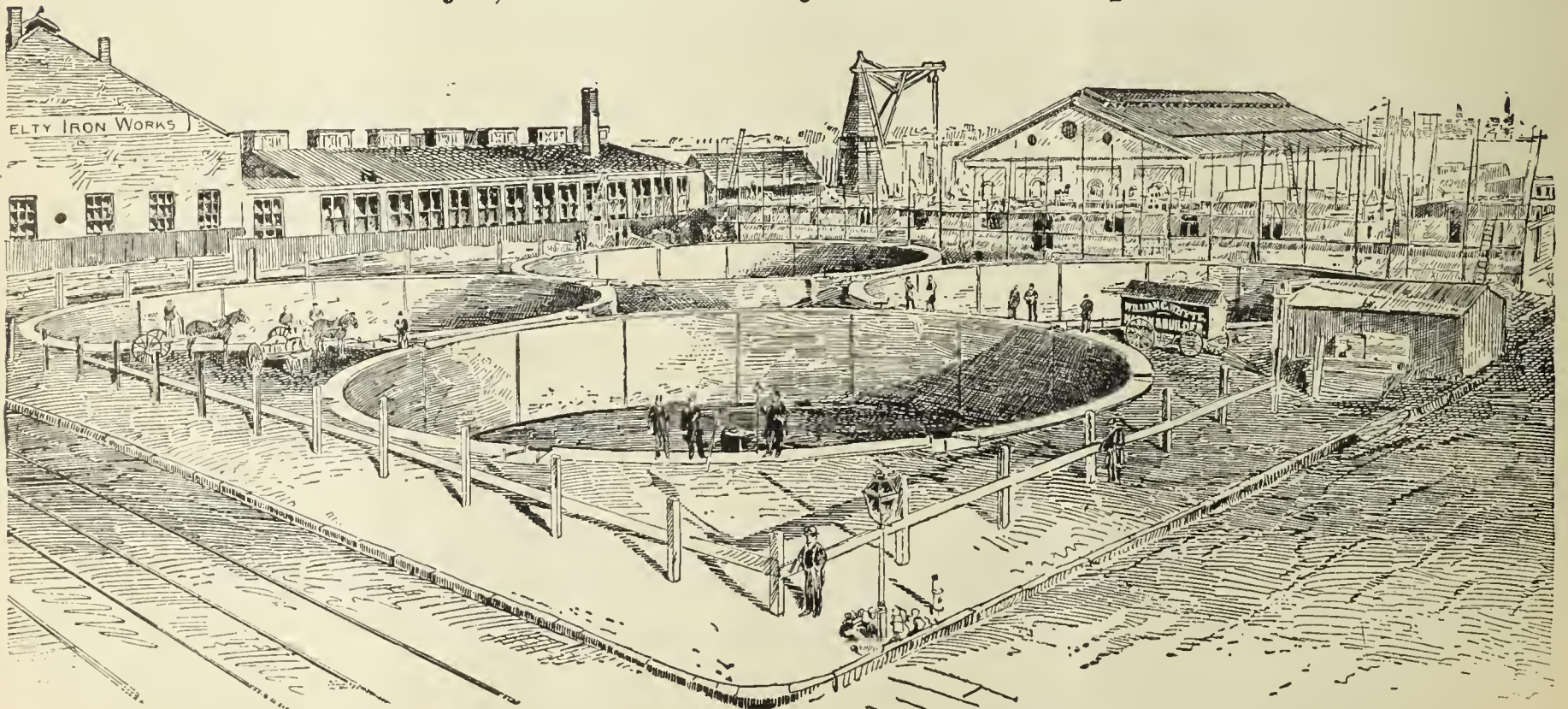

Tank Excavation and Mason Work.

Fifty Tanks now in operation show the sort of work done. Address

W. C. WHYTE, - No. 15 Cortlandt Street, N. Y. City.

CONNELLY & CO.,

SOLE MANUFACTURERS OF THEIR PATENTED SPECIALTIES.

"IRON SPONGE." Saves money, saves labor, and is the most efficient purifying agent ever offered as a substitute for lime. Now used in every State in the Union, and purifying daily over thirty-five million cubic feet. Should be used in every gas works. Its own saving will pay for it many times over.

AUTOMATIC GOVERNOR. Has been on the market but three years, and in that time has been introduced more generally than any invention ever designed for use in gas works. Over two hundred of them now in use. Sensitive; reliable; perfectly automatic; reduces leakage; satisfies consumers, and gives great relief to the Manager. No gas works is complete without one of these machines.

STEAM JET EXHAUSTER. Designed particularly for small works. Combines Exhaust Tube, Steam Governor Gas Compensator, and Bye-Pass Valves in the most compact form possible; occupies but little space; uses very little steam; operated by ordinary workmen; saves formation of carbon in retorts; increases yield 10 to 15 per cent. Specially adapted for mixing air with oil gas. No works too small to use them profitably.

Prices given on all our specialties delivered at any point in the United States. Correspondence solicited.

CONNELLY & CO., No. 111 Broadway, New York City.

WILBRAHAM GAS EXHAUSTER & ENGINE COMBINED.

WILBRAHAM BROS.,
PHILADELPHIA, PA.

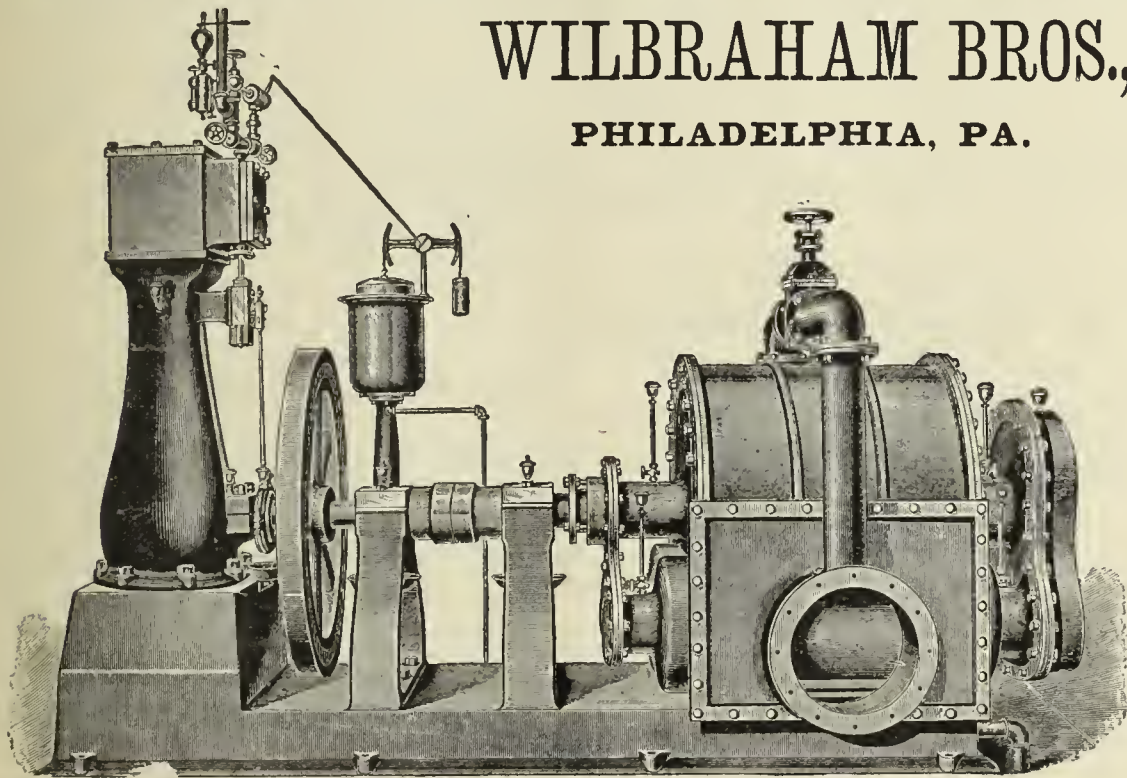

JARVIS ENGINEERING CO.,

61 Oliver St., Boston, Mass.

CONTRACTORS FOR ERECTING

COMPLETE STEAM OUTFITS FOR ELECTRIC LIGHTING STATIONS.

Steel Boilers set with Jarvis Pat. Boiler Setting

To burn **COKE SCREENINGS** for Fuel.

ARMINGTON & SIMS CO. ENGINES,

Belting direct to Dynamos, without using Shafting.

SEND FOR CIRCULARS.

REFERENCES.—Charlestown Gas & Electric Light Co., Charles town, Mass.; Schenectady Gas & Electric Light Co., Schenectady N. Y.; Brookline Gas Co., Brookline, Mass.

Practical Electric Lighting

By A. BROMLEY HOLMES, A.M.I.C.E.

With 87 Illustrations. Third Edition. Price, \$1.00.

Electric Light Primer.

By CHARLES L. LEVEY.

A simple and comprehensive Digest of all the most important facts connected with the running of the Dynamo and Electric Lights, with Precautions for Safety, etc.

Price, 50 cents.

A. M. CALLENDER & CO., 42 Pine St., N.Y.

COMPOUND Condensing or Non-Condensing.
16 SIZES, 5 to 500 H. P.

Not yet equaled by any form of Engine for
HIGH FUEL DUTY AND SIMPLICITY.

STANDARD 13 Sizes in Stock.
5 to 250 H. P.
3000 in use in all parts of the Civilized World.

JUNIOR 6 Sizes in Stock,
5 to 50 H. P.

An Automatic Engine cheaper than a Slide Valve.
WELL BUILT. ECONOMICAL. RELIABLE.
Over 300 Sold the First Year.

All the above built strictly to Gauge with
INTERCHANGEABLE PARTS.

REPAIRS CARRIED IN STOCK.

SEND FOR ILLUSTRATED CATALOGUES.

WESTINGHOUSE ENGINES
The Westinghouse Machine Co.
PITTSBURGH, PA. U.S.A.

SELLING DEPARTMENT IN THE UNITED STATES.

New York,	47 Cortlandt St.	} Westinghouse, Church, Kerr & Co.
Boston,	Hathaway Building,	
Pittsburgh,	Westinghouse Build'g,	
Chicago,	156, 158 Lake St.	
Philadelphia,	608 Chestnut St. M. R. Muckle, Jr. & Co.	
St. Louis,	302, 304 Washington Av.	} Fairbanks & Co.
Kansas City,	312 Union Avenue,	
Denver,	1330 Seventeenth St.	
Omaha,	1619 Capitol Avenue, F. C. Ayer.	
Pine Bluffs, Ark.	Geo. M. Dilley & Sons.	
Salt Lake City,	259 S. Main St.	} Utah & Montana Machinery Co.
Butte, Mont.	L. Granite St.	
San Francisco,	21, 23 Fremont Street,	} Parke & Lacy Co.
Portland, Or.	33, 35 N. Front St. Parke & Lacy Mch. Co.	
Charlotte, N. C.	36 College St.	} The D. A. Tompkins Co.
Atlanta, Ga.	45 S. Prior St.	
Dallas, Tex.	Keating Imp. & Machine Co.	
Chattanooga, Tenn.,	C. E. James & Co.	



CHAPMAN VALVE MANUFACTURING CO.,

MANUFACTURERS OF

Valves and Gates for Gas, Ammonia, Water, Etc.

Also, Gate Fire Hydrants With and Without Independent Nozzle Valve. All Work Guaranteed.

WORKS & GEN'L OFFICE:
Indian Orchard, Mass.

TREASURER'S OFFICE:
72 Kilby & 112 Milk Sts, Boston, Mass.

LUDLOW VALVE MFG. CO.

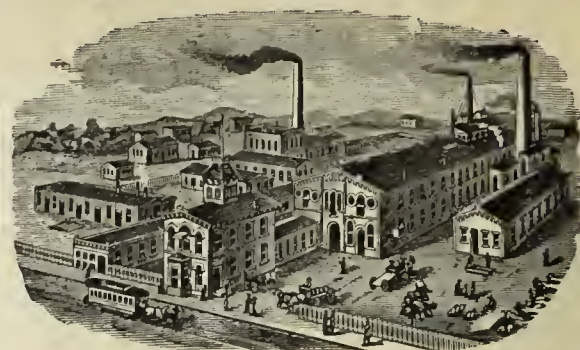

OFFICE AND WORKS,

938 to 954 River Street and 67 to 83 Vail Av.,
TROY, N. Y.

GEO. SHEPARD PAGE,

No. 69 Wall Street, N. Y. City.

REPRESENTING

THE BOWER GAS LAMP.

C. & W. Walker's Carbonic Acid & Tar Extracting Washer

B. DONKIN & CO.'S PAT. IMP. GAS VALVE.

Young & Beilby's Patents. Henry Aitkin's Patents.

R. P. SPICE, London, Eng. HENRY SIMON, Manchester, Eng.

MILLS' REVERSIBLE LIME TRAY,

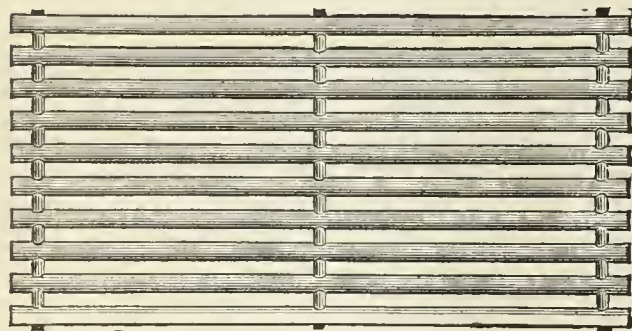

AND

WOODWORK

Of Every Description

NEEDED BY GAS WORKS.

SEND FOR CIRCULAR AND PRICE LIST TO

BARTLETT, HAYWARD & CO.,

Pratt and Scott Streets, Baltimore, Md.

Hydraulic Main Dip Regulators, also
Check Valves, Foot Valves, Yard-
wash and Fire Hydrants.
Send for Circulars.

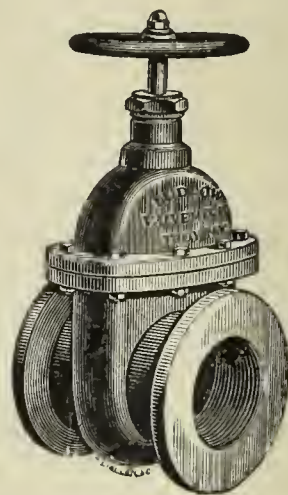

Valves.—Double and Single Gate, ½ in. to
48 in., outside and inside Screws. Indica-
tor, etc., for Gas, Water, Steam, and Oil.
Send for Circulars.

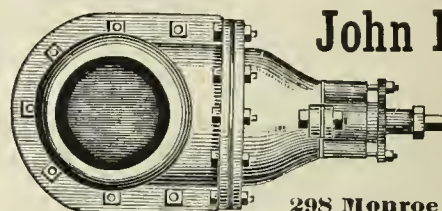

John McLean

Man'facturer

**GAS
VALVES.**

298 Monroe Street, N. Y.

SPECIAL TRAYS FOR IRON SPONGE OR OXIDE OF IRON.
CHURCH'S TRAYS A SPECIALTY.
REVERSIBLE—STRONGEST—MOST DURABLE—MOST EASILY REPAIRED.

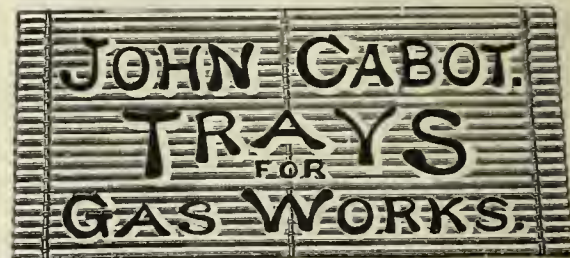

306-310 ELEVENTH AVENUE, NEW YORK.

WE ALSO MAKE THE CHEAPEST AND STRONGEST
REVERSIBLE BOLTED TRAYS IN THE MARKET.

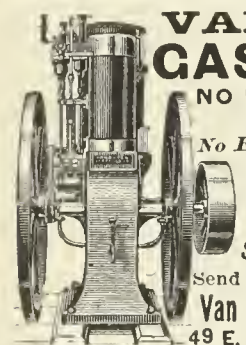

**VAN DUZEN
GAS ENGINE**

NO BOILER. NO COAL.
NO ENGINEER.

No Extra WATER RENT
or INSURANCE.

INSTANTLY STARTED.
DURABLE, RELIABLE,
SAFE and ECONOMICAL.

Send for description and prices.

Van Duzen Gas Engine CO.,
49 E. 2nd St., CINCINNATI, O.

A. MacKinnon Machine Co., Agts., 22 Warren St., N.Y.

**The Management of Small
Gas Works.**

BY C. J. R. HUMPHREYS.

Price, \$1.

Orders to be sent to **A. M. CALLENDER & CO.,**

42 PINE STREET, NEW YORK.

THE CLERK GAS ENGINE CO.,
Main Office, 1012, 1014, 1016, 1018 Filbert St., Philadelphia, Pa.

WM. W. GOODWIN, Prest.

E. STEIN, Sec.

S. LEWIS JONES, Asst. Sec.

A. J. DOTY, Supt.

The utility and convenience of the Gas Engine being no longer an open question, it only remains now for intending purchasers to select the BEST. We claim for the CLERK GAS ENGINE that it is equal to any other manufactured as regards steadiness in running, simplicity, and ease of keeping in repair, and that it gives the greatest amount of power for the least money (both in first cost and expense of running) of any engine made. In support of this claim we refer to the test of the Gas Engines made under the direction of the American Institute of New York, in December, 1885, and heretofore published in these columns. These engines are especially adapted for continuous running under heavy loads, and we can refer to Engines which have run 22 hours a day for months at a time

Made in Sizes of 5, 10, 15, 20, and 25 Horse Power. All Engines Guaranteed for One Year.

GAS STOVES.

GAS METERS.

GAS STOVES.

THE AMERICAN METER CO.,

MANUFACTURERS OF

GAS METERS, Station Meters,

METER PROVERS, PHOTOMETERS,

PRESSURE GAUGES OF ALL KINDS,



Standard 3 Diaphragm Dry Meter

AND

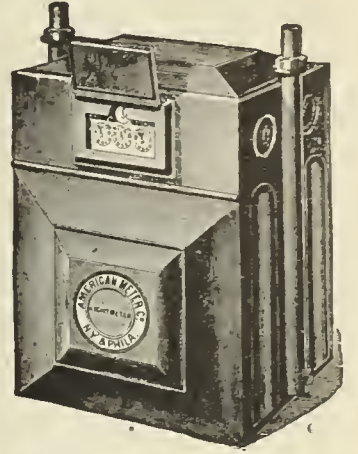

Standard 2 Diaphragm Dry Meter.

Apparatus for Testing the Quantity and Quality of Gases.

GAS STOVES FOR HEATING AND COOKING

Sole Agents in the United States for

Verity's Patent Gas Fires.

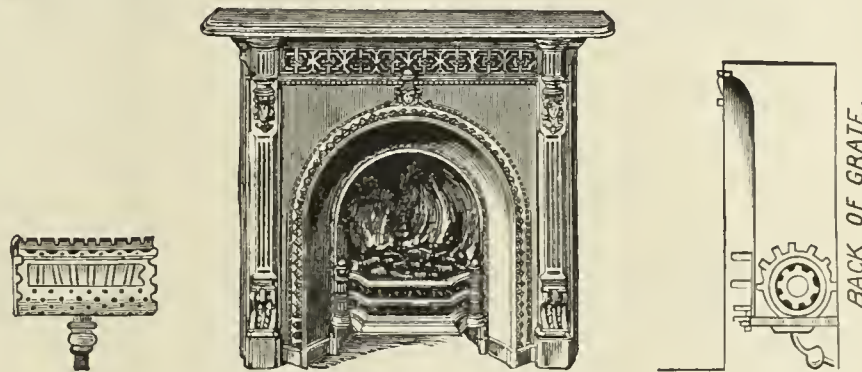

Circulars and Price Lists on Application.

MANUFACTORIES,

508 to 514 West Twenty-second St., N. Y.

Arch and Twenty-second St., Phila.

Nos. 244 & 246 North Wells Street, Chicago, Ill.

AGENCIES,

No. 177 Elm Street, Cincinnati, Ohio.

No. 222 Sutter Street, San Francisco, Cal

No. 810 North Second Street, St. Louis, Mo.

GAS STOVE SHOW ROOMS, No 242 Sixth Avenue, New York City.

RETORTS AND FIRE BRICK.

RETORTS AND FIRE BRICK.

RETORTS AND FIRE BRICK.

J. H. CAUTIER & CO., CORNER OF GREENE AND ESSEX STREETS, JERSEY CITY, N. J.

MANUFACTURERS OF Clay Gas Retorts, Gas House Tiles, Fire Bricks, Etc. Etc. Ground Clay, Fire Brick and Fire Sand in Barrels,

J. H. GAUTIER. C. E. GREGORY. C. E. GAUTIER.

BROOKLYN Clay Retort & Fire Brick Works, (EDWARD D. WHITE & CO.) Manufacturers of Clay Retorts, Fire Brick, Gas House and other Tile. VAN DYKE, ELIZABETH, RICHARDS & PARTITION STS. Office, 88 Van Dyke St., Brooklyn, N. Y.

LACLEDE FIRE BRICK MFG. CO., MANUFACTURERS OF Fire Brick, Gas Retorts,

AND ST. LOUIS STANDARD SEWER PIPE. Blast Furnace and Cupola Linings, every description of Fire Clay Material, Fire Clay Flue Linings, Chimney Tops Dry Milled and Crude Fire Clays, etc. OFFICE AND DEPOT 901, 903, and 905 Pine Street, ST. LOUIS, MO.

ESTABLISHED IN 1845.

B. KREISCHER & SONS, OFFICE FOOT OF HOUSTON ST., E.R., N.Y. Gas Retorts, TILES, FIRE BRICK. AND EVERYTHING IN THE FIRE CLAY LINE.

MANHATTAN FIRE BRICK & ENAMELLED CLAY RETORT WORKS ADAM WEBER. CLAY GAS RETORTS AND RETORT SETTINGS FIRE BRICKS, TILES, ETC., Office and Works, 15th Street and Avenue C., N. Y.

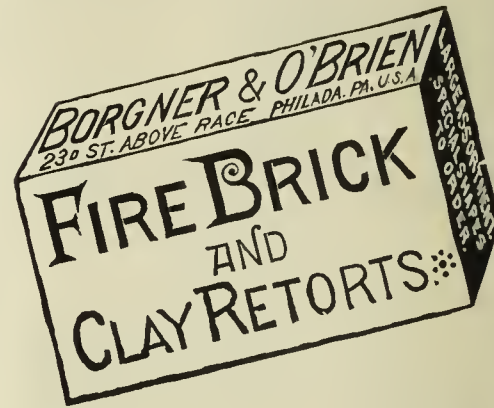

Works, LOCKPORT STATION, PA.

—ESTABLISHED 1864.—

JAMES GARDNER, JR.,

Office, Rooms 19 & 20, Lewis Block, PITTSBURGH, PA, P. O. Box 373.

Successor to WILLIAM GARDNER & SON.

Fire Clay Goods for Gas Works.

CHAS. H. SPRAGUE & SON, No. 70 KILBY STREET, BOSTON, MASS., Agents for the New England States.

GEO. C. HICKS, Prest. CHICAGO CHAS. A. REED, Sec. & Treas. Retort and Fire Brick Co., MANUFACTURERS OF Fire Clay Goods of all Kinds, AND BEST QUALITY ONLY. Regenerative Furnaces & Water Gas Goods. 45th St., Clark to La Salle, Chicago.

GEROULD'S IMPROVED RETORT CEMENT. A Cement for patching retorts, putting on mouthpieces, and making up all bench-work joints. This Cement is mixed ready or use. Economie and thorough in its work. Fully warranted o stick. For recommendations and price list address C. L. GEROULD & CO., 5 & 7 Skillman St., Brooklyn, N. Y. Western Agent, H. T. GEROULD, Mendota, Ill.

Parker-Russell Mining and Mfg. Co., CITY OFFICE: { Me. mod-Jaccard Bldg., Rooms 307 & 308, Broadway and Locust Street, St. Louis, Mo. PROPRIETORS OF THE OAKHILL GAS RETORT & FIRE BRICK W'KS

Our immense establishment is now employed almost entirely in the manufacture of materials for GAS COMPANIES. We have studied and perfected three important points. Our retorts are made to stand changes of temperature, the strongest heats of the furnace, and the abrasion of feeding and emptying. We furnish and build Half-Depth or Full REGENERATOR FURNACES of different kinds and most approved styles. Correspondence solicited.

THOS. SMITH, Prest. AUGUST LAMBLA, Vice-Prest. & Supt. BALTIMORE RETORT & FIRE BRICK CO. MANUFACTORY AT LOCUST POINT, BALTIMORE, MD.

Clay Retorts, Blocks & Tiles, FIRE BRICK, FIRE CLAY, AND FIRE CEMENT. Red and Buff Ornamental Tiles and Chimney Tops. Drain and Sewer Pipe (from 2 to 30 inches). Baker Oven Tiles 12x12x2 and 10x10x2. WALDO BROS., 88 WATER ST., BOSTON, MASS Sole Agents the New England States.

1889 DIRECTORY 1889

OF THE GAS LIGHT COMPANIES of the UNITED STATES & CANADA.

Price, \$3.00.

A. M. CALLENDER & CO., No. 42 Pine Street, N. Y. City.

HENRY MAURER & SON,
 (ESTABLISHED 1856.)
EXCELSIOR FIRE BRICK & CLAY
RETORT WORKS
 WORKS, Perth Amboy, N. J.
 OFFICE, 418 to 422 East 23d St., N. Y.
Clay Gas Retorts,
BENCH SETTINGS,
 Fire Brick, Tiles, Etc.

FLEMMING'S
Generator-Gas Furnace

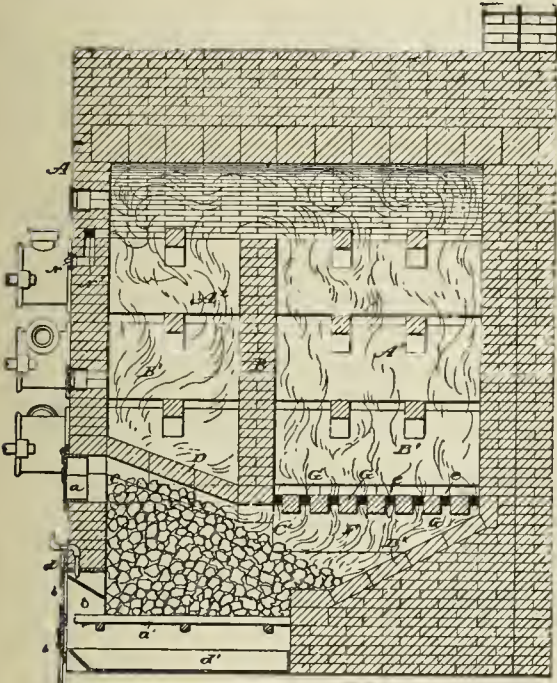

Materials furnished and Benches erected by

J. H. GAUTIER & CO., - Jersey City, N. J.
 Address as above, or D. D. FLEMMING, Jersey City, N. J.

FRED. BREDEL,
 CONTRACTOR FOR THE COMPLETE
Erection and Equipment of Gas Works,
 SOLE PROPRIETOR OF THE
KLOENNE PATENTS
 FOR NORTH AMERICA.

REGENERATIVE FURNACES.

(900 Retorts are now fired in America by the Kloenne-Bredel System.)

SELF-SEALING MOUTHPIECES.

(Over 800 Now in Use.)

Standard Condensers. Washer-Scrubbers.

TAR WASHERS FOR WATER GAS PLANTS.

(In use in the works of the Chicago Gas Lt. Co.)

GASHOLDERS.

Bredel's Automatic Gas Governor.

Refers, by permission, to Mr. Eugene Vanderpool, Newark, N. J.; Mr E. G. Cowdery, Milwaukee, Wis.; and Mr. Theo. Forstall, Chicago, Ills. For further information, address

FRED. BREDEL,
No. 208 East Seventeenth Street, N. Y. City.

Plans and Estimates Furnished for New Works or for the Alteration of Old Works.

HENRY PRATT & CO.,
 BUILDERS OF THE
PRATT & RYAN WATER GAS GENERATORS,
 Arranged to Use Either Crude Oil or Naphtha.
Condensers, Scrubbers, Purifiers, and all Apparatus for Coal or Water Gas.
IRON ROOFS, BOILERS, TANKS, ETC.
 Orders and Correspondence Solicited.

Office and Works,
 869 to 875
 So. Halsted St.
 CHICAGO, ILL.

THE BRENNER SELF-SEALING RETORT DOOR.
Simple, Strong, and Durable.

CLOSES ABSOLUTELY TIGHT & IS LOCKED BY A CAM LEVER. ALL NECESSARY ADJUSTMENT FOR WEAR PROVIDED.

BUILT BY

SMITH & SAYRE MFG. CO.,
No. 245 Broadway, - - - New York City.

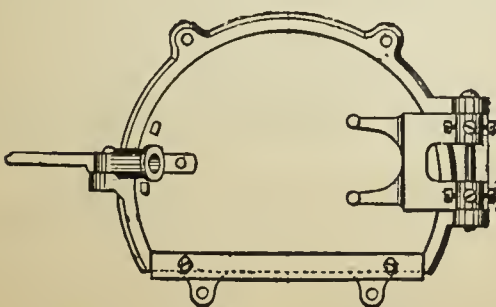

Brenner Self-Sealing Retort Door.

WILLIAM B. LUNDIE, Superintendent of the 42d Street Station of the Consolidated Gas Company, of New York, writes, under date of Jan. 4, 1889:

"We have 320 Brenner Self-Sealing Lids in use at this Station, built by the Smith & Sayre Mfg. Co. They require very little attention, and are the best of the kind that I have seen, giving entire satisfaction."

GAS AND WATER PIPES.

GAS AND WATER PIPES.

ENGINEERS.

SAM'L R. SHIPLEY, Pres.
HENRY B. CHEW, Tre

JAS. P. MICHELLON, Sec.
WM. SEXTON, Supt.

GLOUCESTER IRON WORKS,
GLOUCESTER CITY, N. J.



Cast Iron Gas & Water Pipes, Stop Valves, Fire Hydrants, Gasholders. &c.

Office, Rooms 61 and 63 Bullitt Building, 131 S. 4th St., Phila., Pa.

WARREN FOUNDRY AND MACHINE CO.,

Established 1856. Works at Phillipsburgh, N. J.

New York Office, 160 Broadway.

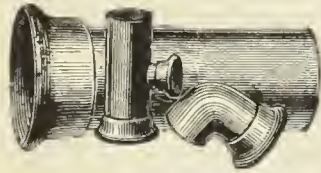

CAST IRON WATER AND GAS PIPE,

FROM TWO TO FORTY-EIGHT INCHES DIAMETER. ALSO, ALL SIZES OF

Flange Pipe for Sugar House and Mine Work. Branches, Bends, Retorts, etc., etc.

DENNIS LONG & COMPANY,

LOUISVILLE, KY.,



Manufacture Exclusively

CAST IRON GAS & WATER PIPE & SPECIAL CASTINGS
OF ALL SIZES.

King's Treatise on Coal Gas.

A standard text-book for the Engineers and Managers of Gas Works, and for all who are concerned or take an interest in the manufacture and distribution of Coal Gas, and in the utilization of the Secondary Products resulting therefrom; treating also of the Gas Engine, and of Gas Cooking and Heating Appliances.

In 3 Vols. Price per Vol., \$10. Sold either by Volume or in Sets.

A M. CALLENDER & CO., 42 Pine St., N. Y.

P. D. WANNER, Chairman. A. H. MELLERT, Mangr. of Wk
R. B. KINSEY, Secretary. F. A. KNOPP, Treasurer.

MELLERT FOUNDRY & MACHINE CO. Ltd.
and **READING FOUNDRY CO., Ltd.,**
Reading, Pa.

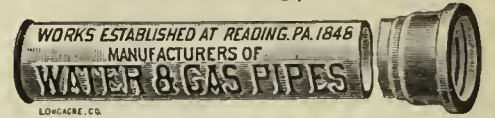

Specials—Flange Pipe, Valves and Hydrants
Lamp Posts, Retorts, etc.

General Foundry and Machine Work.

JOHN FOX, Selling Agent. 160 Broadway, N. Y.

THE OHIO PIPE COMPANY,

MANUFACTURERS OF

Cast Iron Gas & Water Pipe,

BRANCH AND SPECIAL CASTINGS.

Gas-House Bench Castings, Hydraulics, Lamp Posts, Flange Pipe
and Specials, Architectural Castings, Building Columns,
Joists, Cellar Grates, Sash Weights, etc.

GENERAL FOUNDERS AND MACHINISTS.

Columbus, Ohio.

M. J. DRUMMOND,



SPECIAL CASTINGS AND LAMP POSTS.

Office, Corbin Building, 192 Broadway, N. Y.

EMAUS PIPE FOUNDRY.

DONALDSON IRON COMPANY. EMAUS, PA.



MANUFACTURERS OF

CAST IRON PIPE AND SPECIAL CASTINGS
FOR WATER AND GAS.

JOS. R. THOMAS,

No. 42 Pine Street, N. Y. City.

CONSULTING AND CONSTRUCTING

Gas Engineer and Contractor.

PLANS, SPECIFICATIONS, AND ESTIMATES
FURNISHED.

Contracts taken for all Appliances
required at a Gas Works,

Either for New Works or Extensions to Old Plants.

WM. MOONEY

(Successor to WM. FARMER)

No. 94 Liberty St., N. Y. City.

GAS ENGINEER AND CONTRACTOR FOR THE ERECTION
OF GAS WORKS, OR APPARATUS OF ANY
CAPACITY.

Plans and Specifications Furnished.

WM. GARDNER,
Gas Engineer,

Lewis Block, Room 20, Pittsburgh, Pa.

Those who intend to make alterations in existing gas plants, or who contemplate the erection of new works, will find it to their interest to open correspondence with the above. Plans made and estimates furnished.

BARTLETT, HAYWARD & CO.

Baltimore, Md.

Triple Double, & Single-Lift
GASHOLDERS.

Iron Holder Tanks.

ROOF FRAMES.

Cirders.

BEAMS.

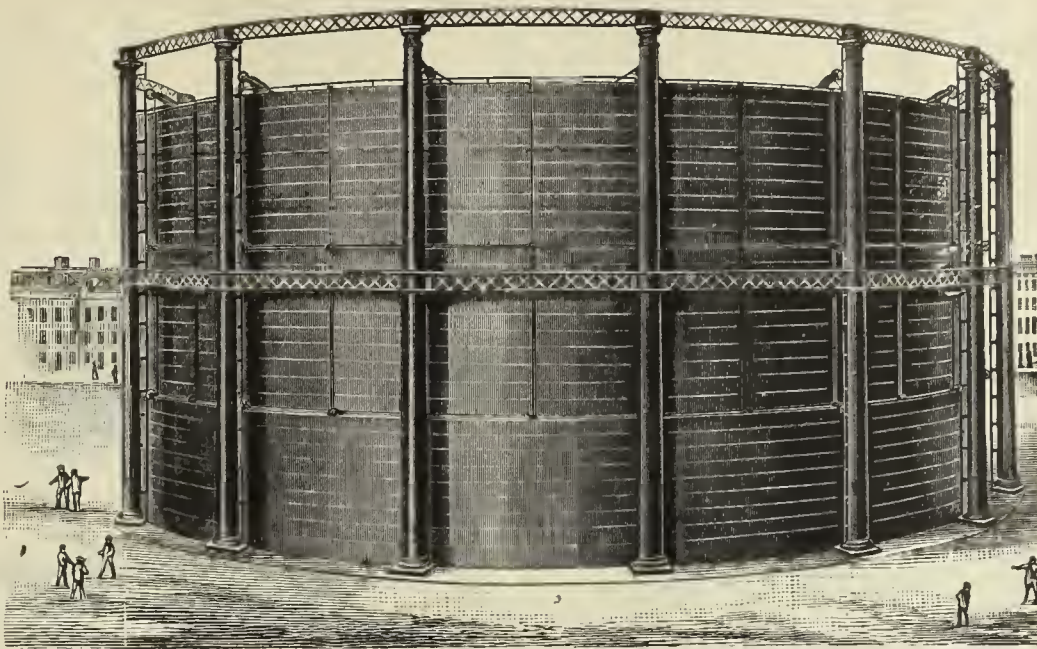

PURIFIERS.

CONDENSERS.

Scrubbers.

BENCH CASTINGS.

OIL STORAGE TANKS.

Boilers.

The Wilkinson Water Gas Process.

THIRTY-CANDLE, NON-CONDENSABLE, FIXED GAS. THE MOST SUCCESSFUL GAS PROCESS IN OPERATION.

Munich Regenerative Furnace, System Drs. Schilling & Bunte.

HAZELTON BOILERS.

Gas Works Designed and Constructed.

Pascal Iron Works. ESTABLISHED 1821. Delaware Iron Works.

MORRIS, TASKER & CO.,

INCORPORATED.

OFFICE, 224 SOUTH THIRD STREET, - - PHILADELPHIA, PA.

CONTRACTORS, BUILDERS, AND MANUFACTURERS OF

Gas, Water & Sugar Works

Bench Castings.

Condensers.

Scrubbers.

Purifiers.

Hyd. Carriages.

Iron Floors,

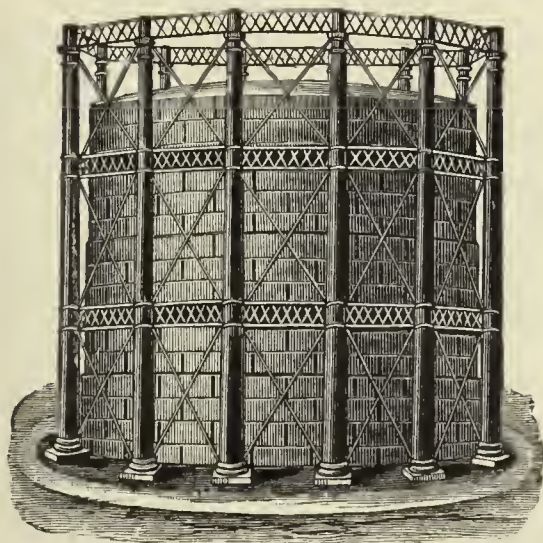

Iron Roofs.

Street Stops,

Valves, etc.

Stand-Pipes.

Water & Oil

Tanks, all Sizes.

Single, Double, and Triple-Lift Gas Holders.

SELF-SEALING RETORT LIDS. STAMPED STEEL RETORT LIDS.

Locomotive Water Columns, Filters, etc. Boiler Tubes, Wrought Iron Pipe & Fittings

Plans, Specifications and Estimates for all kinds of Machinery furnished on application.

Foundries & Works,
MILLVILLE, FLORENCE,
and CAMDEN, N. J.

R. D. WOOD & CO.,

Engineers,
Iron Founders,
and
Machinists.

400 Chestnut St., PHILADELPHIA, PA.

MANUFACTURERS OF

CAST IRON PIPE,

Gas Holders,

SINGLE, DOUBLE, AND TRIPLE LIFTS, WITH
OR WITHOUT WROUGHT IRON
OR STEEL TANKS.

PURIFIERS, CONDENSERS.

Scrubbers.

BENCH WORK.

Iron Floors and Roofs, Plate Girders.

Heavy Loam Castings.

HYDRAULIC WORK.

Lamp Posts, Valves, Etc.

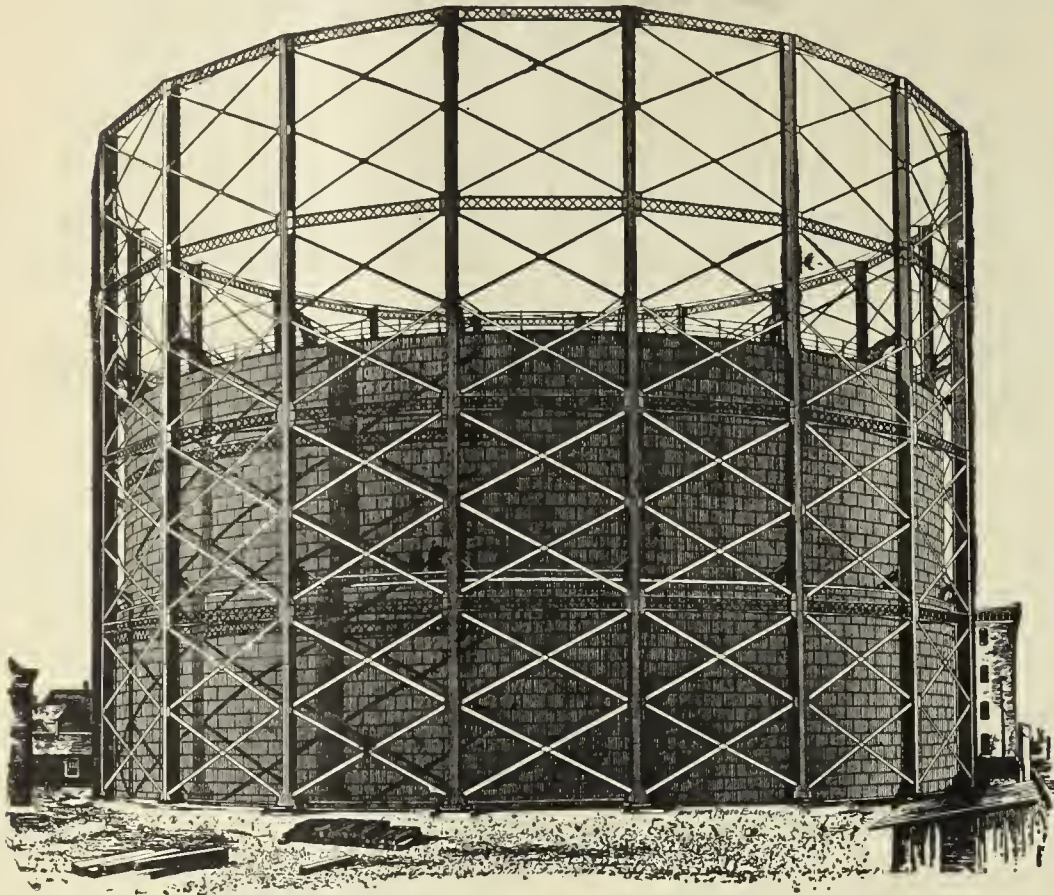

ROOTS' NEW GAS EXHAUSTER.

The Only
Exhauster
Made with
Provision for
Taking up
Lost Motion
or Wear.

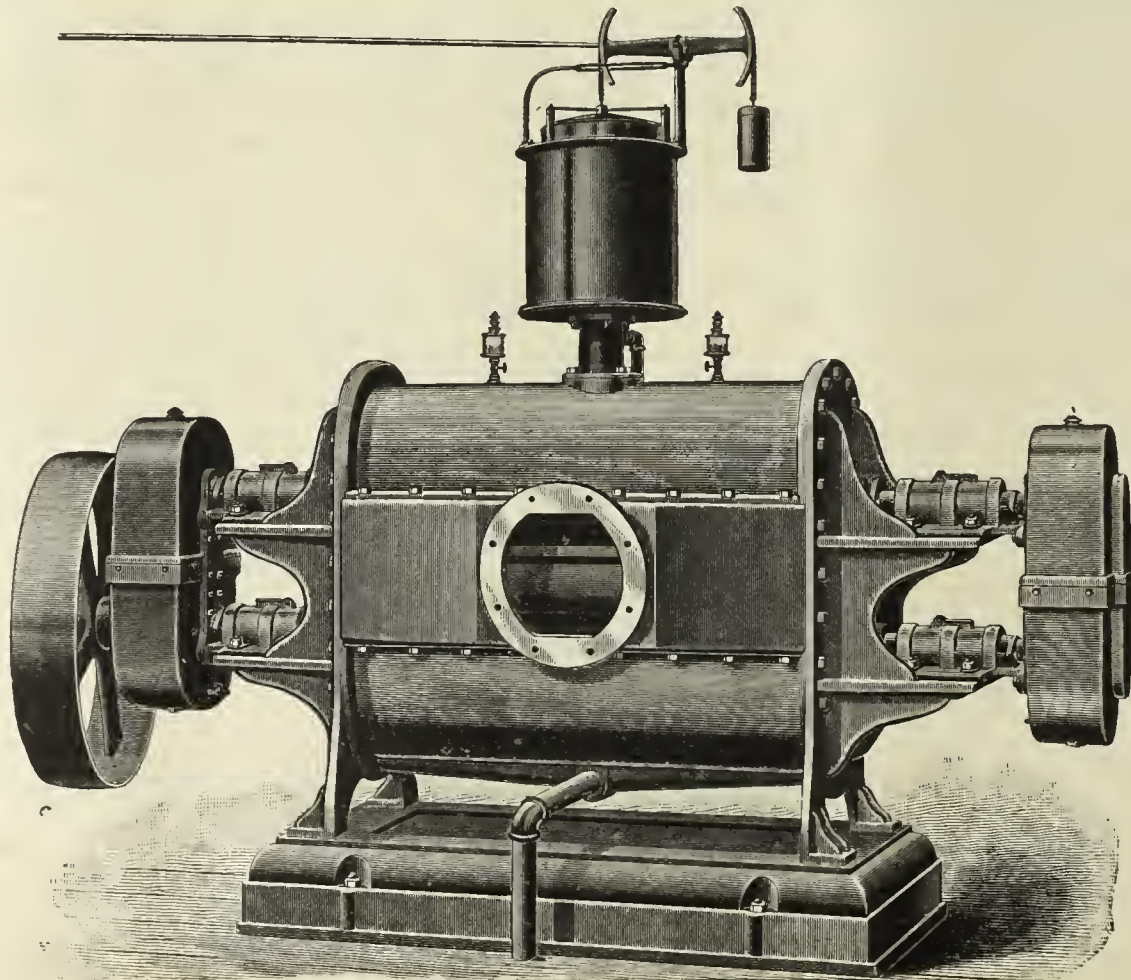

All Parts
Requiring
Alteration
are External
and Easily
Accessible.
at all Times.

Send for Descriptive Catalogue and Price List.

P. H. & F. M. ROOTS, Patentees and Manufacturers, CONNERSVILLE, IND.

S. S. TOWNSEND, Gen. Agt., 22 Cortlandt St., N. Y.

COOKE & CO., Selling Agts., 22 Cortlandt St., N. Y.

GAS WORKS APPARATUS AND CONSTRUCTION.

GAS WORKS APPARATUS AND CONSTRUCTION.

JAMES R. FLOYD & SONS,

(SUCCESSORS TO HERRING & FLOYD)

Oregon Iron Works,

W. 20th & 21st. Sts., bet. 10th & 11th Avs.,

NEW YORK CITY.

Engineers and Contractors

FOR THE

CONSTRUCTION OF GAS WORKS.

MANUFACTURERS OF

All Kinds of Castings and General Ironwork

FOR

GAS APPARATUS.

Bench Castings, Regenerative and Half Regenerative Furnace Castings.

Condensers, Scrubbers, Purifiers, Street Drips and Connections,

Valves,

Hydraulic Hoisting Purifier Carriage, Self-Sealing Retort Lids, Improved Valve Stand and Indicator,

Seller's Cement.

Plans, Specifications, and Estimates furnished for Construction of New or Alteration of Old Works.

CONTINENTAL IRON WORKS.

THOS. F. ROWLAND, Prest.

WARREN E. HILL and CHAS. H. CORBETT, V-Prests.

THOS. F. ROWLAND, JR., Sec. & Tr

P. O. Station G., BROOKLYN, N. Y.

ENGINEERS AND MANUFACTURERS OF

Gas Holders

CONDENSERS, SCRUBBERS, VALVES,

PURIFIERS, SELF-SEALING RETORT LIDS

Hydraulic Mains,

And all other articles connected with the manufacture and distribution of Gas.



H. RANSHAW, Prest. & Mangr.

WM. STACEY, Vice-Prest.

T. H. BIRCH, Asst. Mangr.

R. J. TARVIN, Sec. & Treas.

STACEY MFG. CO.,

MANUFACTURERS OF

Single and Telescopic Gasholders,

IRON ROOFS, BRIDGES, LAMP POSTS,

Water and Oil Tanks, Coal Elevator Cars,

COKE CRUSHERS, BENCH CASTINGS,

And all kinds of Wrought and Cast Iron Work used in the erection of Coal and Oil Gas Works Rolling Mill Machinery and Heavy Castings a Specialty.

Foundry:

33, 35, 37 & 39 Mill Street.

Wrought Iron Works:

16, 18, 20, 22, 24 & 26 Ramsey Street:

Cincinnati, Ohio.

Bouton Foundry Co.,

FOUNDERS AND MACHINISTS,

CHICAGO, ILL.

Gas Works Apparatus,

PURIFIERS, CONDENSERS,

Bench Work

SPECIALS, LAMP POSTS,

SCRUBBERS,

Iron Roofs and Floors.

Plans and Estimates furnished for new works or extensions of old works.

1842. **DEILY & FOWLER,** 1889.

Laurel Iron Works.

Address, No. 39 Laurel Street, Philadelphia, Pa.

BUILDERS OF

GASHOLDERS,

Single and Telescopic.

HOLDERS BUILT 1884 to 1888, Inclusive:

- | | | | | |
|----------------------------|-----------------------------|---------------------------|--------------------------|------------------------|
| Newport, R. I. | Long Island City, N. Y. | Port Chester, N. Y. | Malden, Mass. | West Chester, Pa. (2d) |
| Portland, Oregon. | Macon, Ga. | New Rochelle, N. Y. | Paducah, Ky. | Lancaster, Pa. (3d) |
| Allegheny, Pa. (2d.) | York, Pa. | Salem, N. J. (3d) | Norwich, Conn. | Tacony, Pa. (two) |
| Atlanta, Ga. (2d.) | Chester, Pa. | Omaha, Neb. (2d) | Seattle, W. T. | Mount Vernon, N. Y. |
| N.Y. City (Central Gas Co) | Hazleton, Pa. (2d.) | Lynn, Mass. (2d) | San Diego, Cal. | Binghamton, N. Y. |
| Lynchburg, Va. (2d.) | Staten Island, N. Y. | Little Rock, Ark. | Northern Gas Lt. Co., of | Concord, N. H. |
| Saylesville, R. I. | Saugerties, N. Y. | Irvington, N. Y. | New York, N. Y. | Dover, Del. (2d) |
| Rondout, N. Y. | Clinton, Mass. (Lan. Mills) | South Boston, Mass. | Westerly, R. I. | Calais, Me. |
| Atlantic City, N. J. | Chattanooga, Tenn. | Rye, N. Y. (2) | Willimantic, Conn | New London, Conn. (2d) |
| Augusta, Ga. | Galveston, Texas. (3d.) | Woodstock, Ont. | Montclair, N. J. | West Chester, N. Y. |
| Waltham, Mass. (2) | Omaha, Neb. | Malden, Mass. | Attleboro, Mass. | Bay Shore, L. I. |
| Mahanoy City, Pa. | Fort Plain, N. Y. | Staten Island, N. Y. (2d) | Santa Cruz, Cal. | Washington, D. C. |
| New Castle, Pa. | Brunswick, Ga. | Woodstock, Ont. | Erie, Pa. (2d) | |

SMITH & SAYRE MFG. COMPANY,

G. G. PORTER, Prest.

245 Broadway, N. Y.

CHAS. W. ISBELL, Sec'y.

Machinery & Apparatus for Gas Works

Drawings, Plans, and Estimates Furnished for the Improvement, Extension, or Alteration of Gas Works, or for the Construction of New Works.

Mackenzie's Patent Rotary and Steam Jet Gas Exhausters, Governors, Compensators, Condensers, Washers, Scrubbers. Isbell's Patent Automatic Street Pressure Governor, Gas and Water Valves, Hydraulic Main Dip Regulator, Bench Castings, etc. Purifying Boxes and "Standard" Scrubbers, Isbell's Patent Self-Sealing Retort Doors.

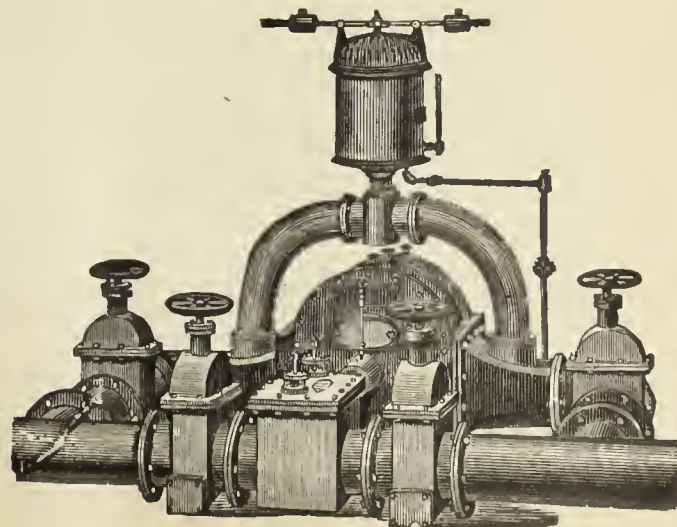

GAS COALS.

CANNEL COALS.

GAS ENRICHERS.

JAMES D. PERKINS. **PERKINS & CO.,** F. SEAVERN.
 228 & 229 Produce Exchange, New York.
 Cable Address, "PERKINS, NEW YORK." Post Office Box 3695, New York.

GENERAL SALES AGENTS FOR

The Youghioghenny River Coal Company's

OCEAN MINE YOUGHIOGHENY GAS COAL.

HON. W. L. SCOTT, Prest. M. H. TAYLOR, Vice-Prest.

This Colliery is located at SCOTT HAVEN, PA., in the center of the Youghioghenny Gas Coal District, and produces the ONLY RELIABLE YOUGHIOGHENY COAL for gas purposes. (See Map on p. 87 of this JOURNAL, Feb. 16, '85.)

POINTS OF SHIPMENT,

Locust Point, BALTIMORE. Pier No. 62, PHILADELPHIA.

Also, SOLE AGENTS for the

**BRECKENRIDGE CANNEL,
OF KENTUCKY.**

Within the past two years we have delivered this Cannel to over ONE HUNDRED COMPANIES IN THIRTY-THREE DIFFERENT STATES, and it is now in use in some of the large Gas Works

On the Continent and in South America,

where it successfully competes with the Australian Shale. It is the ONLY AMERICAN GAS CANNEL of sufficiently high grade to warrant EXPORTATION TO EUROPE AND SOUTH AMERICA, and it is the only economical substitute for OIL OR NAPHTHA. ONE GROSS TON will produce

10,000 Cubic Feet of 75 Candle Gas,	} equal to {	750,000 Candle Feet of Gas, and 26 Bushels of merchantable Coke weighing 900 Pounds
or 12,500 " " 60 " "		
or 15,000 " " 50 " "		

This is the ONLY GAS CANNEL that will produce a REALLY MERCHANTABLE COKE. It can be delivered in parcels of one carload or more to any point in the United States or Canada. Cargo shipments of any size required can be made from NEW YORK, PHILADELPHIA, BALTIMORE, or NEWPORT NEWS. Samples will be sent and particulars of price, etc., forwarded upon application to above address.

JAMES & WILLIAM WOOD,
Gas and Cannel Coal Contractors,

No. 40 St. Enoch Sq., Glasgow. No. 2 Talbot Court, London.

Proprietors of the BATHVILLE COLLIERIES (which produce the celebrated BOGHEAD CANNEL), Shields, Shieldmuir, Drumpeller, and other Collieries. This Firm offer

STANDARD CANNELS,

Unequaled as Gas Enrichers.

Also, WEST FAIRMONT GAS COAL, of W. Va.

Analyses, prices, and all further information furnished on application to

Agency for U. S., Room 93, Nos. 2 & 4 Stone St., N.Y. City.

The Standard Oil Company,

REFINERS OF

NAPHTHA AND GASOLINES.

ALSO MANUFACTURERS OF

A Special Grade of Naptha for Gas Companies

FOR ENRICHING COAL GAS.

Correspondence solicited.

No. 43 Euclid Avenue, Cleveland, Ohio.

To Gas Companies.

We make to order CAP BURNERS to burn any amount under a stated pressure. Send for samples.

Also, SERVICE CLEANERS, DRIP PUMPS, and STREET MAIN PROVING APPARATUS.

C. A. GEFRORER,

248 N 8th Street, Phila., Pa.

COKE CRUSHERS.

GAS COALS.

GAS COALS.

Newburgh Orrel Coal and Coke Co.

MINERS AND SHIPPERS OF

STEAM, SMITHING, AND GAS COALS,
Foundry and Crushed Coke.

Home Office, 33 S. Gay Street, Baltimore, Md.

CHAS. MACKALL, Gen. Mangr.
CHAS. W. HAYS, Agent, No. 1 Broadway, N. Y.
Shipping Wharves, Locust Point, Baltimore.

The Despard Gas Coal Co.,

MINERS AND SHIPPERS OF

DESPARD GAS COAL,

AND MANUFACTURERS OF

COKE.

MINES, Clarksburg, Harrison Co., W. Va.

WHARVES, Locust Point, Baltimore, Md.

OFFICE, 225 E. German St., " "

ROUSSEL & HICKS, } AGENTS. } BANGS & HORTON,
71 Broadway, N. Y. } 60 Congress St., Boston.

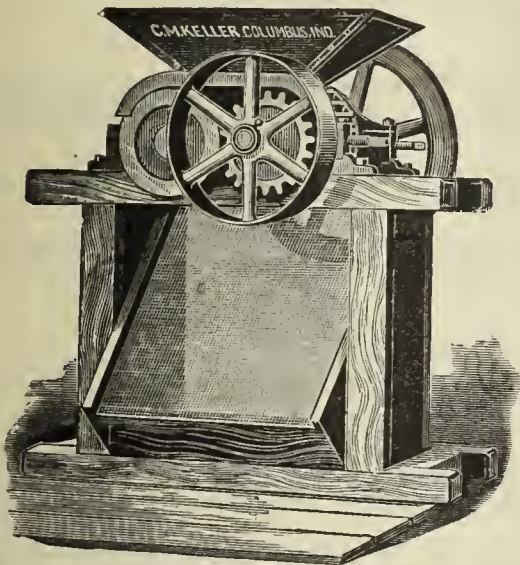

Keller's Adjustable Coke Crusher.

SIMPLE, STRONG, AND DURABLE.

C. M. Keller, Sec. & Supt. Gas Lt. & Coke Co. Columbus, Ind.

Correspondence Solicited.

King's Treatise on Coal Gas.

The most complete work on Coal Gas ever published

Three Vols. Bound, \$30.

THE PENN GAS COAL CO.

OFFER THEIR

Coal, Carefully Screened & Prepared for Gas Purposes.

Their Property is located in the Youghiogeny Coal Basin, near Irwin and Penn Stations on the Pennsylvania Railroad, and on the Youghiogeny River.

Principal Office:

209 SOUTH THIRD STREET, PHILA., PA.

Points of Shipment:

Pennsylvania Railroad Piers; Greenwich Wharves, Delaware River; Pier No. 1 (Lower Side), South Amboy, N. J.

Chesapeake & Ohio Railway Coal Agency,

FOR THE SALE OF THE

Superior Kanawha Gas Coals, Cannelton Cannel,
Also, SPLINT AND STEAM COALS,

From the Kanawha and New River Regions, on the line of the Chesapeake & Ohio R'way.

C. B. ORCUTT, General Agent, - - No. 1 Broadway (Room 217) New York City.

FRANCIS H. JACKSON, Prest. EDMUND H. MCCULLOUGH, V.-Prest. CHAS. F. GODSHALL, Treas. H. C. ADAMS, Sec.

THE WESTMORELAND COAL CO.

Chartered 1854.

Mines situated on the Pennsylvania and the Baltimore and Ohio Railroads, in Westmoreland County, Penn.

POINTS OF SHIPMENT:

PHILADELPHIA, BALTIMORE, SOUTH AMBOY, N. J.,
WATKINS (SENECA LAKE), N. Y.

Since the commencement of operations by this Company its well-known Coal has been largely used by the Gas Companies of New England and the Middle States, and its character is established as having no superior in gas-giving qualities, and in freedom from sulphur and other impurities.

Principal Office, 224 South 3d St., Phila., Pa.

WM. HENRY WHITE,

No. 32 Pine Street, - - - New York City.

ENGINEER AND CONTRACTOR FOR THE

Erection and Extension of Gas, Water, and Electric Light Works.

SOLE REPRESENTATIVE OF THE

McILHENNY REGENERATOR FURNACE PATENTS

And the Martin Water Gas Process.

Edison Incandescent and American Arc Electric Light Plants Installed.

Correspondence with Gas Companies contemplating extending or improving their Plants respectfully invited.
Plans and Estimates Furnished.

GAS METERS.

GAS METERS.

GAS METERS.

JOHN J. GRIFFIN & CO.,

Gas Meter Manufacturers,

Philadelphia, New York
and Chicago,

Will Occupy this Space Hereafter.



Dry Gas Meters.

With 40 years' experience and the best facilities for manufacturing, is enabled to furnish reliable work and answer orders promptly.

NATHANIEL TUFTS,

No. 153 Franklin Street, Boston, Mass.,

MANUFACTURER OF

DRY GAS METERS.

Station Meters of any Capacity.

Test and Experimental Meters, Pressure Registers, Pressure Gauges,
Pressure and Vacuum Gauges.

METER PROVERS, PHOTOMETERS, STREET LANTERNS, ETC., ETC.

Patent Cluster Lanterns for Street Illumination.

250 & 252
Pearl Street,

JOHN HILLEN'S BROOKLYN GAS METER WORKS.

BROOKLYN,
N. Y.

MANUFACTURER OF

IMPROVED GAS METERS

REPAIRING OF METERS (of all makers) a specialty. All defective working parts are replaced without extra charge. A guarantee is given with all work sent from this shop. Write for Price List.

CHARLES E. DICKEY.

JAMES B. SMALLWOOD.

CHARLES H. DICKEY.

THE MARYLAND METER AND MANUFACTURING CO.

Established 1866.

BALTIMORE, North & Saratoga Sts.

CHICAGO, 197 Michigan Street.

NEW YORK, 766 Broadway.

BOSTON, 4 Central Street.

ST. LOUIS, 1115 Olive Street.

SAN FRANCISCO, 330 Pine Street.

CONSUMERS' & STATION METERS, PRESSURE GAUGES, Etc., Etc.

"Success" and "Perfect" Gas Stoves.

SCIENTIFIC BOOKS.

All books forwarded by express, upon receipt of price; if sent by mail, postage must be added to price given. We take pains in forwarding any other Works desired. Remittances by check, draft, or P.O. money order.

KING'S TREATISE ON THE MANUFACTURE OF COAL GAS. Three vols; \$10 per vol.
GAS MANUFACTURE, by WILLIAM RICHARDS. 4to., with numerous Engravings and Plates, in Cloth binding. \$12.
TECHNICAL GAS ANALYSIS. \$3.00.
GAS CONSUMER'S GUIDE. \$1.
A GUIDE TO GAS LIGHTING. 40 cents.
GAS MEASUREMENT AND GAS METER TESTING, by F. W. HARTLEY. \$1.60.
GAS CONSUMER'S HANDBOOK, by WILLIAM RICHARDS, C.E.: 18mo., Sewed. 20 cents.
A PRACTICAL TREATISE ON GAS AND VENTILATION, with Special Relation to Illuminating, Heating, and Cooking by Gas, by E. E. PERKINS. \$1.25.
PRACTICAL TREATISE ON HEAT, by THOMAS BOX. Second edition. \$5.

COAL; ITS HISTORY AND USE, by PROF. THORPE. \$3.50.
THE GAS WORKS OF LONDON, by COLBURN. 60 cents.
THE GAS FITTER'S GUIDE, Showing the Principles and Practice of Lighting with Coal Gas, by JOHN ELDRIDGE. 40 cents.
MUNICIPAL LIGHTING, by F. H. WHIPPLE. \$1.
GAS WORKS, AND MANUFACTURING COAL GAS, HUGHES. \$2.20.
THE MANAGEMENT OF SMALL GAS WORKS, by C. J. R. HUMPHREYS. \$1.
MANUAL FOR GAS ENGINEERING STUDENTS, by D. LEE. 40 cents.
HOW TO MANAGE GAS, by F. WILKINS. Paper. 20 cents.
THE DOMESTIC USES OF COAL GAS, AS APPLIED TO LIGHTING, by W. SUGG. \$1.40.
DISTILLATION OF COAL TAR AND AMMONIACAL LIQUOR, by GEO. LUNGE. New Edition. \$12.50.
ILLUMINATING AND HEATING GAS, by W. BURNS. \$1.50.

A TREATISE ON THE COMPARATIVE COMMERCIAL VALUES OF GAS COALS AND CANNELS, by D. A. GRAHAM. 8vo, Cloth. \$3.
GAS COMPANIES DIRECTORY. \$3.
GAS VERSUS ELECTRIC LIGHT. 50 cents.
THE AMERICAN GAS ENGINEER AND SUPERINTENDENT'S HANDBOOK, by Wm. MOONEY. \$3.
DIGEST OF GAS LAW. \$5.
GAS ENGINE INDICATOR DIAGRAM, by W. E. AYRTON. Paper. 20 cents.
TESTING PIPES AND PIPE JOINTS, by M. M. PATERSON. 80 cents.
DESIGNING WROUGHT AND CAST IRON WORK, by H. ADAMS. Paper. Three parts, 60 cents each.
NOTES IN MECHANICAL ENGINEERING, by H. ADAMS. \$1.
STRAINS IN IRONWORK, by H. ADAMS. With plates. \$1.75.
GAS WORKS—THEIR ARRANGEMENT, CONSTRUCTION, PLANT, AND MACHINERY. \$8.

A. M. CALLENDER & CO., 42 Pine Street, New York.

GAS METERS.

GAS METERS.

GAS METERS.

GEO. J. MCGOURKEY, Prest.

WM. H. MCFADDEN, Vice-Prest. (Phila.)

WM. N. MILSTED, Gen. Supt. and Treas. (New York).

WM. H. DOWN, Sec.

THE AMERICAN METER CO.

WET AND DRY GAS METERS.

PRESSURE REGISTERS.

METER PROVERS.

STATION METERS.

PRESSURE & VACUUM REGISTERS.

PORTABLE TEST METERS.

EXHAUSTER GOVERNORS.

PRESSURE & VACUUM GAUGES.

EXPERIMENTAL METERS.

DRY CENTER VALVES.

CRESSON GAS REGULATORS.

AMMONIA TEST METERS.

GOVERNORS FOR GAS WORKS.

MARSLAND WATER METERS.

BAR & JET PHOTOMETERS.

Manufactories:

512 West 22d St., N. Y.

Arch & 22d Sts., Phila.

GAS STOVES.

SUGG'S "STANDARD" ARGAND BURNERS,

SUGG'S ILLUMINATING POWER METER,

Wet Meters, with Lizar's "Invariable Measuring" Drum.

Agencies:

177 Elm Street, Cincinnati.

244 & 246 N. Wells Street, Chicago.

810 North Second Street, St. Louis.

222 Sutter Street, San Francisco.

HELME & McILHENNY,

(Established 1848.)

GAS METER MANUFACTURERS,

Nos. 1339 to 1349 Cherry Street, Philadelphia, Pa.,

WET AND DRY GAS METERS, STATION METERS, EXPERIMENTAL METERS, METER PROVERS,

Center Seals, Pressure Registers, Governors, Indicators, Photometers, and all other kinds of Apparatus for use in Gas Works.

FOULIS' PATENT STATION AND DISTRICT GOVERNORS.

REPAIRING DEPARTMENT.—We employ a special force of skilled workmen repairing meters of all makers.

WM WALLACE GOODWIN, Prest. and Treas.

WM. H. MERRICK, Vice-Prest.

S. L. JONES, Sec.

S. V. MERRICK, Supt.

THE GOODWIN GAS STOVE AND METER CO.,

Successors to W. W. GOODWIN & CO.

1012, 1014 and 1016 Filbert St., Phila., Pa.

142 Chambers St., New York City.

76 Dearborn, St., Chicago, Ills.

WALDO BROTHERS, Agents, 88 Water Streets, Boston, Mass.

MANUFACTURERS OF

DRY AND WET GAS METERS,

Station Meters (square, cylindrical, or in staves), Glazed Meters, King's and Sugg's Experimental Meters, Lamp Post Meters, etc., etc. Meter Provers (sizes 2, 5, and 10 feet), Pressure Gauges of all kinds, Pressure Registers, Pressure and Vacuum Registers, Pressure Indicators (sizes 4, 6, and 9 inch), King's Pressure and Vacuum Gauges, Dry and Wet Center Seals, Dry and Wet Governors, Exhauster Governors, Photometers of all descriptions. Letheby's Sulphur and Ammonia Test Apparatus complete. Also, Testing and Chemical Apparatus of all kinds, and of the most perfect description, for all purposes relating to Gas.

Manufacturers of the "SUN DIAL" GAS STOVES, for Cooking and Heating.

Goodwin's Improved Lowe's Jet Photometer.

Agents for Bray's Patent Gas Burners and Lanterns.

Special attention to Repairs of Meters and all Apparatus connected with the business. All work guaranteed first-class in every particular. Orders filled promptly.

G. B. EDWARDS, Manager, New York.

S. S. STRATTON, Manager, Chicago.

D. McDONALD & CO.,

GAS METER MANUFACTURERS.

(Established 1854.)

51 Lancaster St., Albany, N. Y. 34 & 36 West Monroe St., Chicago, Ill.

STATION METERS, EXPERIMENTAL METERS, METER PROVERS, PRESSURE & VACUUM REGISTERS, PRESSURE GAUGES, ETC

Also STAR GAS STOVES, RANGES, and HEATING STOVES.

We use only the very best materials, and employ the most skilled labor, and by our long experience (32 years) and personal supervision of every detail, we feel justified in assuring the public that our goods will give perfect satisfaction. Every Meter emanating from our establishment will bear the State Inspector's Badge, and will be fully warranted by us. Our Annual and Calendar will be sent to Gas Companies upon application.

GAS STOVES.

GAS STOVES.

GAS STOVES.

THE GOODWIN GAS STOVE AND METER CO.,

1012-18 Filbert St., Phila., 142 Chambers St., N. Y., 76 Dearborn St., Chicago.

Agents, WALDO BROTHERS, 88 Water Street, Boston.

WM. W. GOODWIN, Pres. and Treas.
W. H. MERRICK, Vice-Pres.
S. LEWIS JONES, Sec.

SAMUEL V. MERRICK, Supt.
G. B. EDWARDS, Mang'r, N. Y.
S. S. STRATTON, Mang'r, Chicago.

SOLE MANUFACTURERS OF THE

"SUN DIAL" GAS STOVES,

The Most Economical, Efficient, and Durable Gas Stove Made.

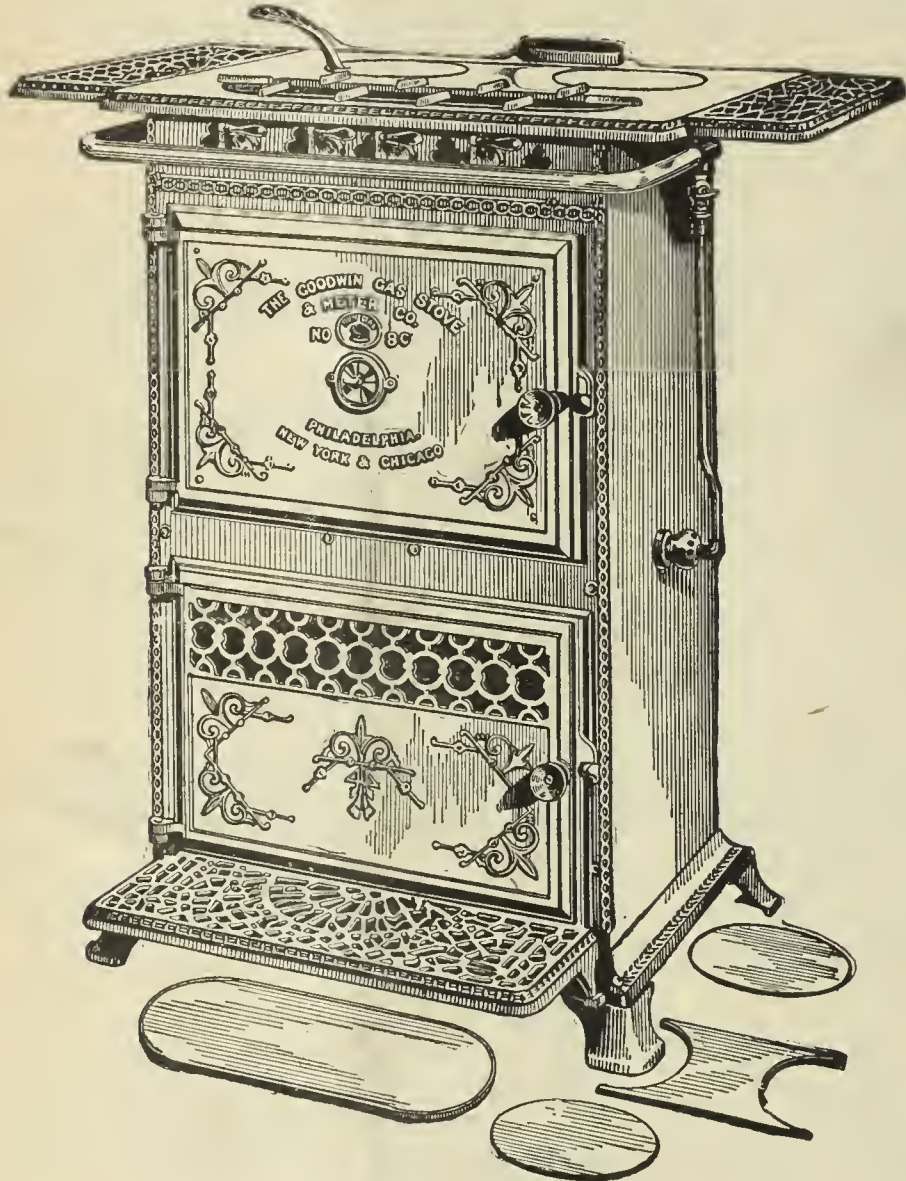

GAS COOKING STOVE, No. 8 C.

SIZE.

Stove.	Oven.	Roaster.	Top.	Length over Extension Shelves.
37 in. high. 20 in. wide.	12 in. high. 17½ in. wide. 12 in. deep.	12 in. high. 18 in. wide. 13 in. deep.	24 in. long. 21 in. wide.	36 in.

This Stove has four burners on top, and double oven burner.
Consumption of gas with all burners in use, 42 feet per hour, at 1 inch pressure.
The top is made in sections, so that a greater variety of cooking utensils may be used.
By lifting out the covers and crosspieces and putting in a suitable forked ring, which is sent with each stove, a wash boiler or other large utensil may be set over two burners.
Our No. 87 GRIDDLE also fits in the same position. The roasting oven is provided with a cast-iron door.

All Fittings are Nickel-Plated.

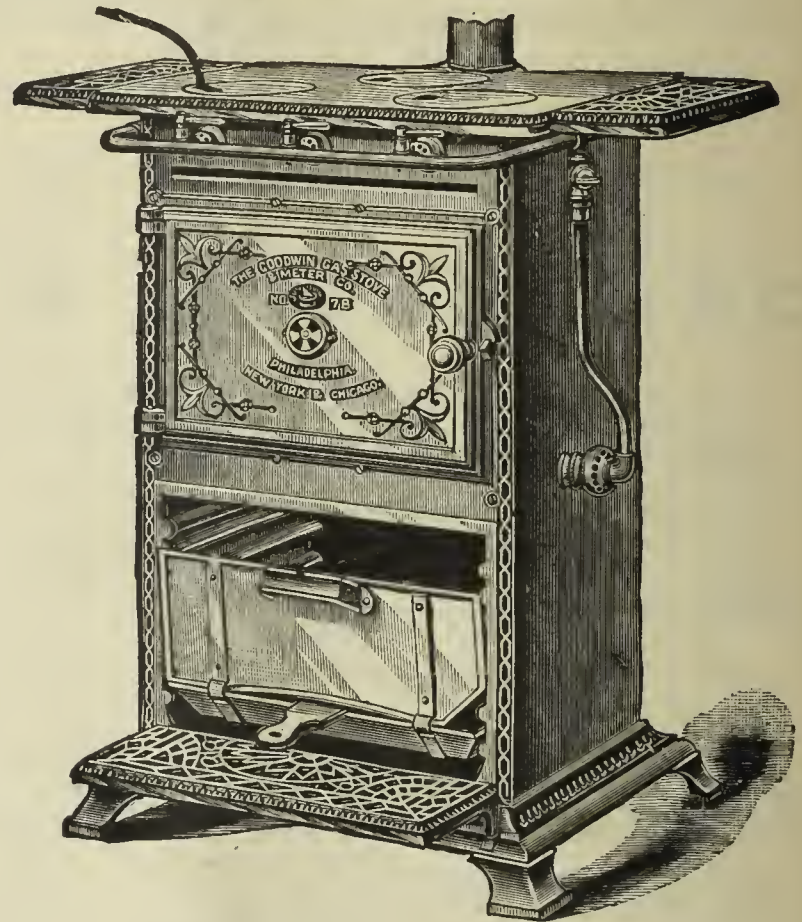

GAS COOKING STOVE, No. 7 B.

SIZE.

Stove.	Oven.	Roaster.	Top.	Length over Extension Shelves.
31 in. high. 17 in. wide.	9½ in. high. 14½ in. wide. 12 in. deep.	10 in. high. 15 in. wide. 13 in. deep.	21 in. long. 18 in. wide.	32 in.

This Stove has three boiling burners in the Top or Hot Plate, and one single oven burner.

This cut represents our New Style Cooking Stove. As will be seen, it has an ornamented cast-iron Base and Front, and extension shelves. The Oven Burner, which is atmospheric (unless otherwise ordered), is of an entirely new and improved pattern (patent). The ovens are of greater capacity than those of the old style. The Top, in conjunction with the Outlet Pipe, is designed to carry off all the products of combustion, if desired, but they are also supplied with a loosering which converts it into an ordinary open top stove.

The consumption of this Stove is 33 cubic feet per hour at 1 inch pressure, with all Burners in use.

All Fittings are Nickel-Plated.

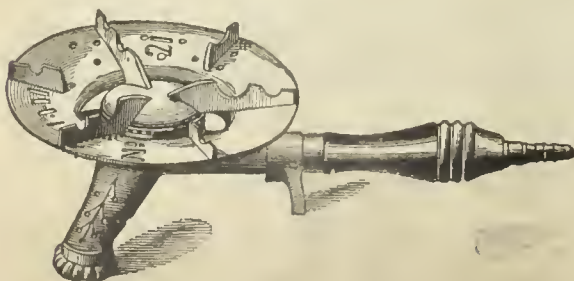

"RADIANT" BOILING STOVE, WITH REGENERATIVE BURNER.

Size, 6½ inches diameter, 3 inches high. Consumption, 6 feet per hour at 1 in. pressure.



HOT PLATE, No. 111.

Size, 36 in. long, 12 in. wide, with three double burners, 6 taps.
Consumption, with all burners in use, 36 cubic feet per hour, with 1 in. pressure.
½ in. supply pipe should be used where the pressure is 1 in. or over.

THE AMERICAN

GAS LIGHT JOURNAL

RODMAN & KENNY, N.Y.

PUBLISHING OFFICE NO. 42 PINE STREET

DEVOTED TO THE INTERESTS OF ILLUMINATION, VENTILATION, WATER SUPPLY AND DISTRIBUTION, & GENERAL SCIENCE.

VOLUME LII.—No. 4. }
Whole No. 764. }

NEW YORK, MONDAY, JANUARY 27, 1890.

{ \$3 PER ANNUM,
IN ADVANCE. }

A. M. CALLENDER & CO., Proprietors. C. E. SANDERSON, Manager.
JOS. R. THOMAS, C.E., Editor. T. J. CUNNINGHAM, Asst. Editor.

ENTERED AT THE POST OFFICE AT NEW YORK, N. Y.
AS SECOND CLASS MATTER.

CONTENTS.

An Asterisk (*) denotes an illustrated article.

OFFICIAL NOTICES—

Annual Meeting, New England Association of Gas Engineers.....	101
Ohio Gas Light Association.....	101

EDITORIALS—

Obituary—Oliver E. Cushing.....	101
Obituary—Theobald Forstall.....	102
Briefly Told.....	102
Annual Meeting, Poughkeepsie (N. Y.) Company—Annual Meeting, Consolidated (N. Y. City) Company.....	102
The Market for Gas Securities.....	102
Looking Backward, By Mr. J. L. Hallett.....	103
Utilization of Residuals from Coke Manufacture.....	104
The Limiting Pressure upon Foundations.....	105
Origin of the Rock Pressure of Natural Gas in the Trenton Limestone of Ohio and Indiana.....	105
Mr. Trewby on the Manufacture of Water Gas.....	106
Paints and Painting for Iron Work.....	107
Special English Correspondence.....	108

Gardner's Gas Coke—The Rights of the Sweep—Recent Strikes—Dangers of Civilized Life—Mr. G. C. Trewby on Water Gas.

ITEMS OF INTEREST FROM VARIOUS LOCALITIES..... 109

In Charge at Fort Worth, Tex.—At Washington, Ind.—Changes at Chicago, Ill.—Sale of the Danville, Ill., Company—Cheaper Edison Service, Boston, Mass.—New Secretary, Lexington, Ky.—Annual Meeting, Spencer, Mass.—Public Lighting, Linwood, O.—A Novel Suit—Annual Election, Citizens Company, Newark, N. J.—Some Gas Trust Figures—Annual Meeting, Hartford, Conn.—A Municipal Electric Plant for Fort Worth—Annual Meeting, Niagara Falls, N. Y.—The Phoenix (Ariz.) Works—Public Lighting, Clinton, Iowa—Hints from Tonawanda, N. Y.—Letter from Mr. Page—Points from Alton, Ill.—Annual Meeting, Williamsport, Pa.—Annual Meeting, Brooklyn (N. Y.) Company—New Gas Company, Mansfield, Mass.—And Many Other Items.

[OFFICIAL NOTICE.]

New England Association of Gas Engineers.

SECRETARY'S OFFICE, BIRMINGHAM, CONN., Jan. 10, 1890.

The Twentieth Annual Meeting of the New England Association of Gas Engineers will be held at Young's Hotel, Boston, on Wednesday and Thursday, Feb. 19th and 20th. The meeting will be called to order on Wednesday, at 10 A.M., by the President, Mr. R. B. Taber.

At the present moment it is impossible to give a list of the papers which will be read at the meeting, but it is hoped that the literary part of the programme will equal any of those held in past years.

Persons eligible for membership who desire to join the Association will please communicate with the Secretary, who will forward at once blank form of application. CHARLES H. NETTLETON, Sec'y.

[OFFICIAL NOTICE.]

Ohio Gas Light Association.

OFFICE OF SECRETARY,
COLUMBUS, O., January 20, 1890.

To Members of the Ohio Gas Light Association:

Gentlemen—The Sixth Annual Meeting of this Association will be held at Toledo, O., on March 19 and 20, 1890.

This announcement is made thus early in order that all members may be reminded of the meeting in ample time to make their arrangements to

be present. Every member is urged not only to attend this meeting, but also to interest himself in inducing others of his acquaintance who are eligible for membership, but who have not as yet joined the Association, to come to the meeting and become members.

It is not intended that as many papers as usual shall be presented at the forthcoming meeting, in order that more time than formerly may be had for the discussion of those that are read, and for such other matters and business as the members may desire to dwell upon.

Although the Secretary has for some time been engaged in the work of soliciting papers for this meeting, he has not yet secured as many as should be had, notwithstanding fewer are desired than heretofore, and he therefore earnestly calls upon all members who can possibly do so to notify him immediately of their willingness to furnish papers.

It has been decided that an interesting and valuable feature of our meeting would be a "Question Box," in which members can place questions, which will be withdrawn and read to the meeting and answered and discussed by the members. Every member is requested to send to the Secretary at once any question or questions which he would like to have thus brought before the meeting.

Future circulars will announce further details concerning the meeting.

Respectfully, IRVIN BUTTERWORTH, Sec'y.

OBITUARY—OLIVER E. CUSHING.

Again are we called on to record the death of a member of the fraternity whose persuasive personality and cheerful manner had always been potent in making for him a warm place in the hearts of his confreres—a place that once gained by him was never made vacant, so strong was his hold on the gentle force of retaining through innate merit and goodness and loveliness a friendship once sealed in the pact of companionship. The shining mark so unerringly aimed at by death in this instance was afforded by Oliver E. Cushing, who since 1860 had been agent and engineer of the Lowell (Mass.) Gas Light Company. Neither was the dread visitor ever a more silent conquerer. About a fortnight ago deceased experienced an attack of the prevailing influenza, but his seeming recovery had been to all appearances rapid—in fact on the day preceding his death he was able to leave his room—but even in the act of congratulating himself on his recovery an attack of heart failure carried him off. However, the end was painless, death claiming him at an early hour of the morning of the 17th inst. In accordance with our custom we herewith publish an account of his life, which can be accepted as substantially correct.

Oliver Edwards Cushing was born at Chelmsford, Mass., in March, 1829, and almost within view of his birthplace was the whole of his useful life spent. Having received an education in the local public schools, graduating with honor from Phelps Academy, in 1845, the tendency of which was to fit him for the profession of an engineer, he, in various positions, proved his worth and merit for business direction, and his success was such that the proprietors of the Lowell Gas Light Company—Chelmsford is but 3½ miles southwest of Lowell—invited him, in 1860, to the post of agent of their Company. To those not intimately familiar with the plan of conducting business corporations in some of the East-

ern States it might be well to explain that an agent is the virtual manager of his company, and in the case of Massachusetts gas companies the agent is usually the engineer also. So it was with the subject of this sketch, and his capacity as an engineer is shown in the fact that while many of his contemporaries were debating a decade and a half ago how to sell gas cheaply, Mr. Cushing was the leader in so selling it. In fact Lowell may justly claim the distinction of being the banner cheap gas city of America, where the rate for some time back has ruled at \$1.10 per 1,000 cubic feet. We instance this merely to show what a progressive man Mr. Cushing was, and that his progressiveness found vent in action. To speak at length on the growth of the Lowell Company is not necessary here in illustration of Mr. Cushing's success in the management of its affairs. Suffice it to say that he was the zealous and capable director of its fortunes. In other local councils his voice was often heard, and many other local enterprises have been benefited by his direction. He was President of the Board of Trustees of the Lowell Cemetery, Vice-President of the Five Cent Savings Bank, and Clerk of the Vestry Board of St. Anne's Parish, of which church he had always been an ardent supporter. The only public office held by him was a chair in the Board of Aldermen (1885). Of his immediate family his widow and three daughters survive.

Turning now to his more extended relations with the fraternity of the country, the records show that he was one of the party of 16 who, at Boston, Mass., on February 2d, 1871, subscribed to the original articles of agreement forming the New England Association of Gas Engineers—this meeting being the sequel of the sad gathering at Worcester, Mass., of December 18, 1870, when the remains of the late Jas. B. Blake, ex-Mayor, and Engineer of the Worcester Gas Light Company, were consigned to earth. At the initial meeting of the Association Mr. Cushing was elected one of its Directors, and although he refused thereafter to occupy higher office in its gift, his voice and presence were ever at its command. He was elected to membership in the American Association at the second annual meeting—Brooklyn, N. Y., October 21, 1874—and his course therein was in accord with his history in the New England body. He became a member of the Society of Gas Lighting in 1876, and, if we mistake not, was a charter member of the Guild of Gas Managers, of which organization he was at one time President. Of all these bodies he was a member at the time of his death, and it need not here be said that his loss will be keenly felt by each.

The funeral services were celebrated at St. Anne's Church, on the 20th inst., the ceremonies being conducted by the Reverend Dr. Chambre, a close friend of the deceased. The attendance was of a most noteworthy character, and could one have banished the knowledge of the sad reason why all were gathered in the sacred edifice, it would seem as if a joint conclave of the Guild of Gas Managers and the New England Association was in session at Lowell.

The moral that is to be drawn from this concise narrative of a busy, useful and even life, is that the gas industry of this country owes its present stability to the quiet though persistent efforts of such pioneers in its history as Oliver E. Cushing and others of his type. In conclusion, we have but to say—and our acquaintance with the deceased covers a period of over a quarter of a century—that a kindlier gentleman nor a more faithful friend than Oliver E. Cushing ever found refuge from the cares of life in the repose of the grave.

OBITUARY—THEOBALD FORSTALL.

Before the first shock occasioned by the news of the sudden death of Mr. Cushing had abated, came a renewal of our sadness in the intimation that Mr. Theobald Forstall, of Chicago, Ills., had gone over to the majority. It is true that we were aware and shared with others in the apprehension so created that Mr. Forstall's tenure of life had been more than uncertain for some months back—but whoever of the living can accept with equanimity at once the bald fact that one's relative, co-laborer or friend lies quiet in death? Mr. Forstall had for months been suffering from a malady that resisted all the skill of his physicians to ward off its insidious attacks, but many months, if not years of useful life seemed to be yet before him. The prevailing scourge that has so deeply set its mark on almost all the peoples of the globe aggravated his disease, to which he fell a victim on the evening of the 19th inst.

Deceased was born in New Orleans, La., in 1836, and traced his lineage back to the earliest French settlers of that section, many of his relatives having taken great part in the religious, civil and warlike events that make up the history of that section of our country when it was yet a French dependence. At an early age deceased was thrown completely on his own resources, and adversity soon developed those latent resources that would have made him successful in any branch of industry,

and which did cause his name to be known, almost as a household word, wherever the art of gas making is practiced. In 1856 we find him located in Stillwater, Minn., where, at the age of 20, he was in control of an important business enterprise, relinquishing the same in 1860 to engage in the shipping business at his birthplace. The outbreak of the civil war all but bankrupted him, and next we find him in the Confederate army, from which he was soon released as invalid. In 1864 he became a bookkeeper in the counting-room of the New Orleans Gas Light Company, where his great knowledge—deceased was always a remarkably close student and a most retentive observer—soon brought him outside the narrow precincts of the counting-room. Shortly, then, he was named General Manager of the Company, and this was followed by his appointment (in addition to his other duties) as the Company's Engineer. In 1874 he was elected to membership in the American Association—2d annual meeting, Brooklyn, N. Y., 1874—and the potency of his personality was soon felt in its affairs. He was an earnest advocate before it of the abolition of Sunday labor in gas works, and his remarks on that subject, while commanding widespread attention to the subject, also directed the notice of his confreres towards himself. Although always something of an invalid, his bodily ills were in no wise reflected in his vigorous mentality. Logical, calm and just, he was not to be diverted by bombast nor influenced by flattery. Perhaps the ablest paper ever read before the American Association was that contributed by him to the third semi-annual meeting (Washington, D. C., May, 1875), on the subject of "The Proper Preparation of Lime for Use in the Purification of Coal Gas." At all events it established completely in this country Mr. Forstall's fame as an engineer. He served the Association as Vice-President in 1881-2, and was its President in 1883. In 1887 he became a member of the Society of Gas Lighting, and joined the Western Association at the Chicago meeting, 1888. There can be no doubt about the fact that to Mr. Forstall's ability and service much of the prestige attained by the American Association is due.

In 1882 three cities—St. Louis, Philadelphia and Chicago—bid for his services in connection with the engineering management of certain gas works. He elected to go to the last named, there to assume the Vice-Presidency and General Management of the Chicago Gas Light and Coke Company, and became President of the latter corporation after the Trust agreement was an accomplished fact—he resigned the Presidency on the occasion of the last annual meeting, Jan. 13th. The wonderful success achieved by him at Chicago is still too fresh in the minds of our readers to require recounting here. Taking hold of the affairs of the Company at a period when everything in connection with it was awry—a worn-out plant, sharp competition that savored of anything but fairness, and a disquieted host of customers—it required a steady hand and stout heart to master the difficulties that presented themselves. He solved the riddle and served his employers in a fashion that will cause his course to be long remembered by those who were dispassionate observers of the contest. But the victory was all too dearly bought. Anxiety and long vigils completed the wreck of a constitution at best never robust, and now the highest penalty has been exacted from him. It admits of no doubt that if ever a man wrecked himself on the deck of action that man was Theobald Forstall. He was in his leisure hours—unhappily, of late, all too few—a delightful companion, whose delicacy and wit were only outshone by his candor and polish. His wife and nine children survive him.

At the annual meeting of the Poughkeepsie (N. Y.) Gas Company Mr. W. H. Young was elected President, vice Mr. E. S. Atwater, resigned. Mr. Atwater has consented to act as legal adviser of the Company, retains his interest in the enterprise, and continues to hold his place as Director. Mr. Atwater accomplished much during his occupancy of the chair.

At the annual meeting of the Consolidated Company of this city the following Trustees were chosen: Gen. Chas. Roome, Thos. K. Lees, Oscar Zollikoffer, Thomas Rutter, Harrison E. Gawtry, Percy R. Pyne, Sam Sloan, Jas. W. Smith, Henry Day, John P. Higgins, H. Clausen, Jr., Wilson G. Hunt and Eugene Higgins.

The Market for Gas Securities.

Consolidated keeps making a net advance during each week, and today (noon, Friday) is at 97½ bid, offered at 98. Apart from its intrinsic worth as an acceptable investment to ordinary investors, these shares have been largely absorbed within the last three weeks by companies (fire and life insurance, etc.) who seek safe and profitable places for a portion of their surplus funds. Other city shares are strong and higher, and the same applies to Brooklyn. Baltimore Consolidated holds its advance, being at 52½-53. Bay State (Boston) common is at 23 to 24, and this stock seems to us at the figure to be worth looking into. Advices from all points are favorable to the shareholder.

[A Paper read before the Society of Gas Lighting.]

Looking Backward.

By MR. J. L. HALLETT, SPRINGFIELD, MASS.

This is a retrospective glance seemingly not unprofitable for us to consider at this time; for, in the light of the past and present condition of the gas lighting business, we may be able to discern and at least partly shape the pathway of the future.

Prior to 1871 there was neither a Society of Gas Lighting nor a kindred Association in this country devoted to the consideration and advancement of matters connected with gas engineering and manufacture. The gas manager stood alone, securely entrenched and fairly independent of outside influences respecting the growth of his business; and he had none of the care and worry of those in ordinary mercantile trade, with one or more competitors in the same block. He was particularly favored in that he controlled a monopoly, "With none to molest or make afraid."

The soliciting of business was unheard of; it must come to him. Every foot of service pipe, meter connections, each burner and every hour of labor taken up in completing the laying on of a gas supply were charged to the consumer, and at a handsome profit, too. Even a tax was levied for the use of that indispensable machine, of equal benefit to both producer and consumer—the meter—which furnishes the only effectual method of determining the quantity of gas sold, and accordingly the size of the gas bill.

Fifteen-candle power gas and a yield of 3.5 cubic feet per pound of coal carbonized was thought creditable, while a shrinkage of 20 per cent. in distribution was of slight concern, not worth digging for; for, at the prices charged, the shareholders were reasonably satisfied with the profits. True, it is thought that the fathers lived up to the light of their day and should not be severely criticised.

Gas Light Associations and weekly issues of papers devoted to the lighting industry have since multiplied, and both have found and imparted knowledge on the subject of gas and electric lighting which could in no other way be obtained. To these sources much credit is due for the brilliant progress made in our business during these later years.

Competition and would-be competitors—cheap oil with improved lamps and burners and electric lighting—have stimulated the gas manager to greater activity. With improved furnaces and settings the yield has nearly doubled, the waste has been reduced to a minimum, and the candle power is 25 per cent. greater, while the price charged is less than the product cost in the earlier days.

The custom of charging for setting meters and meter rental is almost wholly discarded. For the old-style closed globe and iron burner, with its flickering light, opal, etched and ground shades, with large opening and automatic governing burners have been substituted, producing a soft, steady and pleasant light. Formerly 3 candles per foot of gas was the maximum standard attained, but that is now in some States the minimum low limit. No company could exist with that power light against the present competing lights.

The high candle power burners of recent invention, developing 17 candle power per cubic foot of gas, have met the public demand for more light, and are boons to gas companies. What the outcome of this service will be we can only predict. Is it unreasonable to assert that in the near future the inventor will devise a burner—embodying the principles of the Lungren, Wenham, arc, and other high candle lamps, suited to parlor, library, and store fixtures, and in appearance not unlike the incandescent electric lamp, but devoid of shadows—that will develop 85 candle power in place of the common 5-foot burner of 18 to 20?

The efficiency of such a substitute would reduce the cost of lighting to so low a figure that few, if any, incandescent electric lamps would be found in public places, and new impetus would be given the gas lighting business. As 17 candles per foot is now developed in the larger burners, may a commensurate result not be attained in a divided light with a corresponding lessening of cost and heat?

The encircling of the town or city with electric wires, cutting out the hundreds of gas lamps, means a diminution of many million feet, which is a serious loss. Neither is it a pleasant thing to see the names of many of our best customers, of years' standing, dropped from the gas ledger by the inroad of a competing light company, with our only alternative to erect an electric plant or purchase from others a franchise of doubtful profit.

Because of the large increase in population and general business prosperity, the effect of the pushing electric companies has not yet been felt on the output. In fact, an increase is generally reported. These electric companies, in my opinion, would not in any sense be our competi-

tors were the charges for electric light put on a commercial paying basis. This is evident from the large number of electric light companies that, having sunk their entire capital and sold out for a sum equivalent to their debts, have either gone into insolvency or are doing business at a loss. While this is the case, it is equally true that as the electric light becomes no longer a novelty, and it is demonstrated that for the same money more light can be obtained from gas, with more reliable service, former patrons return either wholly or in part to gas lighting. However, it is said that electric lighting companies have come to stay, and that they will demand and secure a share of the lighting business.

The problem, then, for us to consider is how to meet this competition and increase the yearly output. Without borrowing from the future for supposable or hoped-for devices for improving and further diminishing the cost of lighting with gas, how are the fires to be kept burning, and how is our revenue to remain intact, with the resources at our present command?

Fortunately there is a remedy. The gas manager has three strings to his bow—light, heat, and power. The last two have hitherto been secondary forces, and, comparatively, very little attention has been given to their development. Thanks to the meter and other manufacturers, the stoves, ranges, and other appliances for domestic and mechanical purposes, and gas engines for power, have reached a state of perfection that for efficiency and economy can without hesitation be recommended.

We might differ in opinion as to the best method for introducing such apparatus, but all will agree that the greater number of such devices that are put into practical use, either by gift, sale, or rental, the better it is for the receipts of the company.

Our policy in regard to stoves is, whenever possible, to sell them at cost, believing that an article that costs something will be more appreciated and have better care than if the property of others. A few ranges have been loaned at a nominal rental to those that could not afford to purchase.

To show what a limited knowledge the consumer has of these appliances. In a canvas made last summer we found some who did not know what a gas stove was. Many others were prejudiced, and thought the daily use of gas for cooking would be a ruinous expense. To overcome these prejudices, and to demonstrate the efficiency and economy of such a use of gas, 275 stoves were given away. These helped the sale of 248 more. The result was that the skeptical were more than pleased, and their old kerosene stoves were discarded forever. Statements were made by some that, to their surprise, the cost for gas was no greater than it had previously been for oil. The revenue from these gift stoves in one season paid for their cost and yielded a profit to the Company beside.

Without special advertising or any unusual effort to dispose of stoves, excepting in the case given, in four years 1,100 stoves have been placed, which, with those previously sold, make a total of about 1,900 now in use in our city.

The effect these have had on the output is shown in part by the amount of gas distributed from 8 A.M. to 3 P.M. in the months of June, July, August and September:

	June.	July.	August.	September.	
1886....	314,000	298,000	251,000	313,000	= 1,176,000 cu. ft.
1887....	317,000	314,000	431,000	485,000	= 1,547,000 "
1888....	488,000	527,000	540,000	614,000	= 2,169,000 "
1889....	568,000	633,000	604,000	720,000	= 2,525,000 "

This last item multiplied by three, to cover the gas used morning and evening, would give 7,575,000 cubic feet, the approximate amount to the credit of gas stoves in four months being 4,000 feet to each stove. This is 38 per cent. of the whole output for the summer months, and nearly one-tenth of the total output for the entire year.

While the increase in make in the months named in four years was 40 per cent., the increase in the stove consumption was 115 per cent.

In addition to cooking stoves and ranges, 48 heating stoves, of an improved pattern, and very effective for the work required of them, were sold for fall, winter and spring use—a total of 571 stoves in the year.

Looking backward and looking forward, here is a field that legitimately belongs to our craft for their occupation. The people only have to be taught the advantages that may be obtained by them in the use of gas for domestic and mechanical purposes and they will gladly adopt these appliances.

Systematic efforts would bring surprising results.

THE City Council of Poughkeepsie, N. Y., have awarded the contract for public street lighting to the Electric Light Company, at its bid of \$113 per arc per annum, while the Poughkeepsie Gas Company is to light the public buildings, at the rate of \$1.75 per 1,000 cubic feet,

Utilization of Residuals from Coke Manufacture.

Mr. C. M. Percy is contributing a series of articles to the *Colliery Engineer* on the subject of improvements in coke manufacture in Europe, and a most interesting chapter in the series is his comment on the possibility of utilizing the residual products from such manufacture. In referring to the Pernolet system of doing this Mr. Percy says:

Before describing his apparatus in detail Mr. Pernolet proceeded to estimate the reduction in the price of producing coke which would result from the process. The supplementary products, due to the improved arrangements, were a larger yield of coke, and all the tar, the ammoniacal liquors, and the gas which would be obtained from the same coals if distilled in the retorts of a gas manufactory.

The increase in the yield of coke depended partly on the kind of coal, and partly on the way in which the charging was done before the introduction of the improvements. In the great coke works at St. Etienne, where ovens with hemispherically vaulted tops were used, the yield of coke had been advanced from 58.8 to 69.3 per cent., and at another establishment from 54.6 to 69.5 per cent.

In general it might be said that the increase in the yield from the rich and partially rich coals was from 10 to 15 per cent. Consequently, in distilling the same quantity of these coals, there would be a return of coke exceeding on an average one-sixth that which was obtained from the old ovens before their alteration. As to the tar, the amount collected depended on the nature of the coal, and on the care taken both in the distillation of the coal and in the condensation of its volatile products. This proportion had averaged 2.53, 3, 3.25 per cent., and had reached even as high as 5 per cent. where only very bituminous coals were employed. Taking, therefore, the average of these various averages, the amount of tar obtained from the bulk of coal distilled may be taken at 3 per cent.

The proportion of ammoniacal liquors depends not only on the conditions mentioned for the coke and tar, but also on the quantity of moisture contained in the coal.

At one works where unwashed coal was used, for every 100 parts of coal distilled there was not obtained much more than 6 parts of ammoniacal liquor; while at several other works, where the distillation was principally from washed coal, the quantity of liquor collected amounted to 10 or 12 per cent. But in other respects the useful substances contained did not appear to have any relation to the amount of water collected, and the aggregate of resulting ammoniacal substances showed but little variation for the different coals which had been tried.

Provided the condensation was properly attended to, the quantity might be stated at a weight of not less than 10 pounds, and sometimes of as much as 13 pounds of sulphate of ammonia per ton of coal distilled.

The gas obtained had only been computed at the ovens of one establishment, and it was found that by charging the ovens to a height of 2 ft. 4 in., and distilling 6 tons per oven in 72 hours, from 10,000 to 11,500 cubic feet of purified gas were generally obtained from a ton of coal, yielding from 69 to 70 per cent. of coke fit for delivery to the railway companies for locomotive use.

The density of that gas was to that of common air as 40 to 100, and its illuminating power was equal to that obtained from the same coal distilled in retorts, in the ordinary process of gas manufacture; so that the weight of purified gas was about 15 or 16 per cent. of the weight of the coal distilled.

Where coke is manufactured for metallurgical purposes, it is not usual to collect the gas given off, but it is conducted beneath the ovens, to be there consumed in maintaining the necessary temperature for distillation. Provided that the coal is rich or partially rich, this gas will be found sufficient for the purpose (precaution being taken to avoid the risk of explosion); but generally it is desirable to force the heat in order to obtain at once a firmer coke and a tar richer in benzene. This had been obtained without any increased expense, by burning, in addition in the fire-grate, either the small rubbish, which was not good enough to be sold as coke, and which at some places will form from $2\frac{1}{2}$ to 3 per cent. of the coal distilled, or the residue from the washing, which is of usually small value, and may amount to 10 per cent. of the coal distilled.

At one establishment, where the heating of the ovens was entirely performed with gas coke from the retorts, from 22 to 23 per cent. of the weight of coal distilled was burnt; but as the coke contained probably not less than 12 or 15 per cent. of cinder, the consumption stated represented about 20 per cent. of pure coke, that is to say, of carbon. That statement would give an accurate idea of the maximum amount of heat required for ovens then actually in use, which were large and cylindrical

vaulted, 23 ft. 4 in. long, by 6 ft. 8 in. wide, and were provided at both ends with openings the full size of the furnace, closed with cast-iron doors; an arrangement, however, not the most advantageous.

M. Pernolet said that by his improvements in the manufacture of coke, there could be extracted from 1,000 tons of coal 650 to 700 tons of good coke instead of from 500 to 600 tons; 25 to 40 tons of tar; compounds of ammonia, equivalent to at least 5 tons of sulphate of ammonia.

Now, then, as to value of these resulting products. Seven shillings to eight shillings per ton for coke (a very low price indeed; while we write, coke in England is selling at double these prices); twenty to thirty shillings per ton for the tar (that we venture to think will not now obtain;) and £14 to £15 per ton for the sulphate of ammonia (that also is an outside figure;) the total net value of the improvement under the Pernolet system, amounting to £100 per 1,000 tons of coal, or say two shillings per ton.

If it be assumed that at Newcastle, or say, County Durham, and at Wigan, Lancashire, in order to procure one ton of coke, worth say about 8 shillings (certainly a very much under estimate in 1889), it is not at all uncommon to use two tons of rich coal, and this certainly is not uncommon in Lancashire even yet, and that the nature of this coal is such as to permit of the extraction of all the supplementary products. M. Pernolet said it would be seen that the adoption of his ovens would effect a saving of more than four shillings per ton of coke manufactured, and consequently upon a basis of a selling price, eight shillings per ton would reduce the cost of production at least 50 per cent.

But great as even this was, the reduction might be carried still further. If all the gas, or even part of it, were made use of, as there was every facility for doing, particularly in the works which have both coke ovens and gas apparatus, and also in those small gas works where canal coal is generally used, a substantial item of expense might be entirely got rid of by the alteration of some of the ordinary ovens; for the employment of the gas would effect so great an economy as to constitute an advantage equal or even superior to that which could be obtained from the supplementary products estimated at higher prices, because, since on the one hand the gas produced by the improved ovens was capable of supplying all the heat required for the distillation of coal, and on the other hand, the heat can be produced by 20 parts of carbon to 100 parts of coal distilled, it follows that the process of heating would not consume more than 500 pounds of the most ordinary coal to transform into coke a ton of coal yielding in the Pernolet ovens from 10,000 cubic feet to 11,500 cubic feet of gas, at an average expense of one shilling at the highest, or about one penny per thousand cubic feet, or at less than the thirty-sixth part of the lowest price of gas employed in Newcastle, North of England, for the town supply.

[I have very often been struck with the pertinacious manner in which a certain class of inventors will exaggerate the possible benefits of their invention. The gas made and supplied to the principal towns of England not only does not cost three shillings a thousand cubic feet, but can be made and is put into gasholders at less than one shilling a thousand, and neither the Pernolet nor any other system can give us gas at a penny a thousand. We are having just now in England, a craze about water gas, and upon this some excellent criticisms were made at the recent Paris meeting of the Iron and Steel Institute.]

The reduction, says M. Pernolet, in the price of coke effected by the use of his ovens, would generally be at least from four shillings per ton to four shillings and sixpence per ton, and it might amount to eight shillings or nine shillings per ton.

[It really amounts to this, that as compared with the ordinary process of coke manufacture, we should have all the amount of coke we used to make, produced free of cost.]

But it is important to make a more profitable use of the gas than that which it had been applied at the establishments referred to by M. Pernolet; for it was frequently burnt when the most ordinary description of fuel would afford all the heat required, and when the large supply of gas might be increased in value, by reserving it for special purposes, not limited to the lighting of towns, but extended to heating steam boilers or stoves, or the air of blast furnaces, or to evaporating and distilling liquids, puddling cast iron, reducing mineral oxides, and to many other uses of which some had got to be, and no doubt would be, discussed.

[It strikes one upon reading this that hot air for blast furnaces or steam boilers in connection therewith can hardly be included. Blast furnaces as now worked produce sufficient and more than sufficient waste gas to heat all the blast and generate all the steam.]

But sufficiently varied as the best possible purposes which we have named would seem to be, M. Pernolet was not exhausted, and he remarks that it has been proved that one of the elements of illuminating

gas may be transformed into alcohol, and that hitherto that manufacture had only been stopped by the expense of evaporating the dilute sulphuric acid which is present in large quantities. The gas of the Pernolet ovens being able to furnish at once both a supply of alcohol at a low price and a fuel eminently fitted to evaporate it, might perhaps help to introduce the manufacture into the field of commerce.

As regards the use of gas in blast furnaces, for the manufacture of cast iron, an application of it had recently been made in France, by which it was said a purer iron had been obtained, with a saving of 40 per cent. of the fuel usually necessary; and it was also stated that after several weeks' experience twenty Pernolet ovens yielding on an average 20 tons of coke per day, would keep one blast furnace supplied both with coke and gas.

So far, in his remarks, Pernolet had been referring to the employment of the richer, more bituminous kinds of coal, and these were in fact the best adapted for obtaining the products of distillation. But, though the saving would not be so considerable, the Pernolet oven might be profitably used for the poorer coals, and even for the anthracites, provided that some of the richer kinds be used with them. [It is now an unusual occurrence to mix bituminous and anthracite coals for coking. When I visited South Wales last year, I found that the Coppee oven made coke with much success from a mixture. The bituminous coal was too gaseous, and the anthracite coal not gaseous enough, but a proper mixture was found just the thing.]

In such cases the economy would consist chiefly in the smaller quantity of the superior coal required, but of course the products would be proportionally less abundant, in consequence of the small amount of tar, hydrole of ammonia, or gas furnished by the poorer part of the mixture. There would, however, result an important reduction in the price of coke, not only on account of the saving effected in the distillation of the rich coal, but because the poorer kinds, when thus mixed with the richer, instead of being charred alone, would yield three times as much coke as when used singly; in fact, by means of this mixture, it was easy to transform into good coke such coals as were usually considered incapable of being charred, or at least of yielding coke in pieces of an available size.

The collieries of Earl Granville, at Hanley, North Staffordshire, are mentioned as an example where two sorts of coal are used; one flaring, but poor, which had hitherto only been charred in the open air, and in large pieces; and the other partially rich, which was charred in the ordinary ovens—all the poor and comparatively small coal, in pieces less than six inches thick, being rejected. Yet, by mixing it with the partially rich kind found in that neighborhood, and by charring the whole in the Pernolet ovens, the poorer coal might be used with facility, and at least 65 per cent. of good coke would be obtained, instead of the 45 or 50 per cent. produced by the rich coal, when charred by itself in the coke ovens in ordinary use.

In certain cases, also, tar, or dry pitch, might be used with coals which had little or no bitumen, and which were at the same time too brittle to be put into blast furnaces in their crude state. By the admixture of from 8 to 10 per cent. of the above substances, these coals would be supplied with all the bitumen in which they were naturally deficient, and would then become profitable for use in blast furnaces; for if only the small, cheap coal were consumed, the cost of the mixture would not exceed that of ordinary coking coal. Still, the agglomerating matters, being much more expensive than the small coal with which they are combined, it is always important to economize them; and the best way of economizing them is to exclude the air, and thus prevent them from burning, and to collect the products of distillation, and to contribute to their formation during the process.

These recommendations, said M. Pernolet, constitute the leading characteristics of the new system.

The Limiting Pressure upon Foundations.

A writer in the *Mechanical World* notes that very little data is available as to the limiting pressure to which foundations may be subjected. Since the safe load will vary considerably with the nature of the soil, the only satisfactory method of determining this important factor is by direct experiment. In the erection of the weighty and lofty structures on the Champ de Mars, in Paris, in connection with the exhibition, experiments were conducted with this object in view, for the purpose of determining the size of foundations. The method adopted was to level a large surface of ground and place four rectangular blocks of cast iron, 1 foot 8 inches square, so disposed as to form corners of a square, the distance apart being 11 feet 8 inches from center to center. These blocks were bridged by girders of T-iron, and these were then loaded with the

same until a total weight of 143,923 pounds was reached, when a settlement occurred. The pressure on the ground was 7,311 tons per square foot. During the night the settlement increased about $\frac{1}{4}$ of an inch. The load was increased next day to 209,776 pounds, when some of the corner blocks had sunk out of sight, leaving the girders on the surface of the soil. It was found by these experiments that the soil was capable of resisting a load equivalent to 5.43 tons per square foot. When the load reached 7.31 tons, settlement took place, and the ground was incapable of supporting a load of 8.14 tons per square foot.

Origin of the Rock Pressure of Natural Gas in the Trenton Limestone of Ohio and Indiana.

The appended facts are taken from a paper on this subject delivered by Prof. Edward Orton (State Geologist of Ohio) at the New York meeting of the American Geological Society.

Natural gas derived from the Trenton limestone has supplied during the last year, and is now supplying all the fuel and a considerable part of the artificial light that is used by at least 400,000 people in Northwestern Ohio and in Central Indiana. Within the same limits it is the basis of a varied line of manufactories, the annual product of which will make an aggregate of many millions of dollars. More than 40 glass furnaces, not one of them three years old, are now in very successful operation within the territory named, while iron and steel mills, potteries and brickworks, and a long list of factories in which cheap power is a desideratum, have been built up on all sides with wonderful rapidity.

The largest gas production of Trenton limestone that has yet been reached is to be credited to the present year. A well drilled at Stuartsville, six miles north of Findlay, early last summer, produced through the casing, a pipe $5\frac{1}{2}$ inches in diameter, 28,000,000 cubic feet of gas every 24 hours. There are but few wells in any fields that exceed these figures. Most of the wells that have been so reported have been estimated, not measured. An equally astonishing advance had been made in the oil production of this rock, within four counties of Northwestern Ohio. Single wells during the last year have begun their production at a rate of 10,000 barrels a day, and more than 200,000 barrels of total production are already to be credited to single wells of the new field, while a considerable number have passed the 100,000 barrel mark.

The rock pressure of the gas is a vital factor in all this production. To its energy is due the propulsion of the volatile fuel from the wells where it is released through 20, 30, 50 miles of buried pipes to the cities which it supplies with the unspeakable advantages of gaseous fuel. This is the same cause that lifts the oil from the rock in all flowing wells.

By rock pressure is meant the pressure which a gauge shows in a well that is locked in after the drill has reached the gas reservoir. The iron tubing of the well becomes by this means a part of the reservoir, and the same conditions as to pressure are supposed to pertain to it that are found in the porous rock below. The rock pressure of gas varies greatly in different fields, and to a less, but still an important extent, in different portions of the same field. The highest rock pressure recorded in the Trenton limestone is about 650 pounds to the square inch, while there are considerable sections of the gas territory that never reach 300 pounds pressure per square inch. The original pressure in the Findlay field was 450 pounds, varying somewhat in wells of different depths.

In the Wood county field from which the largest amount of gas is now being conveyed to Ohio cities the original pressure ranged from 420 to 480 pounds, the general pressure being counted 460 pounds to the square inch. There were occasional records made of higher pressures still in single wells, but of such cases the number is very small, and the existence of these incredulous pressures was short lived.

In the Indiana field a still greater reduction of rock pressure is noted. The range of the principal Indiana wells is between 250 and 325 pounds to the square inch. The Indiana gas wells, as compared with the Ohio gas wells, are marked by a reduction in total depth as well as in rock pressure, the figures for depth in the productive territory seldom or never passing 1,000 feet.

Sagacious operators are becoming satisfied by their own experience that the root of rock pressure is to be found in the water column that stands connected with the porous rock in which the gas and oil are contained.

When the drill descends into the gas rock proper, dry gas escapes; when into the contiguous and lower-lying terrace, oil accompanied by the gas appears; but at a little lower level salt water is struck, and this rises promptly in the well, sometimes to the point of overflow. Far out from the narrow ridges, or restricted terraces, where gas and oil are found, the salt water reigns undisturbed, and whenever drilled to it, rises in the wells as in those already described.

The rise of the salt water is unmistakably artesian. It depends on hydrostatic pressure, as does the flow of all artesian wells, and its head must be sought, as in other like flows, in the higher portions of the structure that are contiguous. The nearest outcrops of this porous Trenton are found in the shores of Lake Superior, at an altitude of about 100 feet above tide.

It is certainly significant that an abundant flow of salt water is struck in boring in Northern Ohio or in Indiana. No matter at what depth, it rises generally to the level of Lake Superior, or, in other words, about 600 feet above tide. If the mouth of the well is below this level, as in the case in the Wabash Valley, the salt water overflows. The height to which the salt water rises in any portion of the field is one of the elements to be used in measuring the force which can be exerted on the gas and oil that are caught in the traps of the terraces and arches of the porous Trenton limestone.

The rock pressure of the gas differs at various points, because of the difference in depth of the rock below sea level. The rock pressure of Trenton limestone gas is due to a salt water column measured from about 600 feet above tide to the level of the structure which yields the gas.

There is no danger that the great gas reservoirs of to-day will "cave in" or "blow up" after the gas is withdrawn from them. The gas will not leave the porous rock until the salt water obliges it to by driving it out and taking its place. The doctrine lays the axe at the root of all the optimistic theories which blossom out in every district where natural gas is discovered, and especially among the real estate operators of each new field, to the effect that nature will not fail to perpetually maintain or perpetually renew the supplies which we find so delightfully adapted to our comfort and service. So far as we are concerned, it is certain that nature has done about all that she is going to do in this line. In her great laboratory a thousand years are as a single day.

Judging from the present indications, the Trenton limestone gas in Ohio is not likely to be long-lived. It seems entirely probable that the term of its future duration can be expressed within the limits of a number of one digit. In considerable sections of the field the salt water is very aggressive. It requires a steadily increasing pressure on the wells to hold it back.

Mr. Trewby on the Manufacture of Water Gas.

The London *Journal* has interviewed Mr. G. C. Trewby, of London, on his visit to America, with the following result:

The great attention which is now being paid by gas engineers and managers throughout the United Kingdom to the question of the manufacture of water gas, induced us to invite Mr. G. C. Trewby, the Chief Engineer of the Gas Light and Coke Company, to send for publication in these columns a communication giving an account of his recent trip to America, and the results of his investigations, on behalf of his Company, into the various water gas processes which are in operation in that country. Owing to the pressure of business engagements Mr. Trewby could not comply with our request, but courteously suggested that a representative of the *Journal* should wait upon him. The suggestion was carried out a short time since when Mr. Trewby gave a *resume* of the information which he gathered in America. This we now present to our readers practically in Mr. Trewby's own words.

Acting under the instructions of my Company, I recently visited the United States and the borders of Canada, and made myself acquainted with some of the principal carbureted water gas processes in use there. I found in most of the cities that carbureted water gas was more or less manufactured. In New York about two thirds of the supply is water gas, and at Toronto, one-half. At Chicago, on one day in September, when I was there, 7 million out of the 8½ million cubic feet supplied were water gas. At Washington the proportion of water gas varies according to the daily consumption—ranging in the winter time from 35 to 50 per cent. I am not able to give the proportion in all the towns, because I had not time to visit all the companies or works to collect statistics; but it will perhaps be sufficient for me to state that where petroleum spirit or crude oil is bought cheaply the manufacture of water gas is on the increase.

The reasons which have led the different companies to supplement their coal gas supply with water gas have been, in the first place, the cheapness of petroleum; and, secondly, the desire on the part of the public to have a higher illuminating power. In some of the towns companies have been started for the exclusive purpose of manufacturing nothing but carbureted water gas under special patents. In New York there are three distinct Companies who make nothing but this gas, besides the Consolidated Company, who make something like one-half. The illuminating power of the water gas supplied in New York is about

30 candles; and the peculiarity about this high illuminating power is that the gas burns with a clear white flame without any appearance of smoking. It has been found to satisfy the public requirement of a high candle power, and is a successful rival of the electric light wherever introduced. In the case of some few works that I visited where coal gas of about 16-candle power was supplied, the consumption had fallen off year by year during the last few years, and the electric light had made considerable advance. As far as I was able to judge there does not seem to be much consumption of the gas for cooking and heating purposes; but this may be accounted for by the price ranging from 5s. to 8s. per 1,000 cubic feet.

A good deal has been said about the deleterious nature of water gas by reason of the large percentage of carbonic oxide it contains. Plain water gas contains about 40 per cent. of carbonic oxide. But in carbureted water gas the proportion is reduced to about 32 per cent., and by specific processes even below that. The quantity in ordinary coal gas is about 6 per cent. Of course, there is no prejudicial effect produced by burning a gas containing a large percentage of carbonic oxide. The danger is that when an escape takes place fatal effects are likely to be produced much sooner by breathing an atmosphere of this kind than with an atmosphere of coal gas. Notwithstanding this, I was informed that during the seven years water gas has been used in Chicago not a single death could be traced to this cause.* The old Boston Coal Gas Company, who opposed the introduction of water gas some years ago, induced the Legislature of Massachusetts to pass a law limiting to 10 per cent. the maximum amount of carbonic oxide to be allowed in that city; and although this would allow of an admixture of water gas equal to 16 per cent. of the whole bulk, yet it has been found impossible to make anything like this quantity and still get within the limit, because the water gas and coal gas could not be thoroughly mixed together, and the official tester might be able to find some particular point where more than the allowed 10 per cent. of carbonic oxide existed. The present Boston Gas Company hope to have the law abrogated, especially as Massachusetts is the only State in the Union that has passed it; and, as far as I am aware, nothing of the sort exists in Canada. This being the state of the case, I think there is no fear of any legislative action that would interfere with the judicious use of carbureted water gas in this country.

Passing on to a description of the manufacture of water gas, I may shortly state that it is a very old invention; some patents in connection with it being taken out by Kirkham in 1852. The gas is produced in a vessel after the style of an iron cupola—either rectangular or circular—which is filled with anthracite coal or coke. The heat is brought up to the point of incandescence by blowing air into the cupola; and the products of combustion are allowed to pass off into the air. The next operation is the making of the water gas, which is effected by shutting off the air, and blowing superheated steam through the fuel. The steam being composed of hydrogen and oxygen, these two gases are separated. The former passes off in a free condition, and the latter combines with the carbon of the fuel, and forms carbonic oxide. These two gases, together with some carbonic acid and nitrogen, and a small percentage of sulphureted hydrogen, form what is known as crude water gas. The effect of the steaming is, of course, to bring down the temperature of the fuel. Therefore, at the end of ten minutes, this has to be discontinued, and the mass of fuel blown up again with air; and about every two hours or oftener, fresh fuel has to be added.

There are three distinct methods of carbureting the water gas. One is known as the Tessie du Motay process. In this the gas is taken to a small gasholder which acts as a governor; thence it is led into a carbureting vessel supplied with naphtha; and from there it passes up to the fixing retorts, which are ordinary clay gas retorts. The water gas and naphtha go in at one end of a 20-foot retort, and out at the other end as a fixed gas; the contact with the red-hot sides making the fixing permanent. The gas then passes into the hydraulic main, and from thence through the washers, etc., in the ordinary way to the gasholders, I was told that, in the cold weather, the gas does not suffer any greater loss in illuminating power than cannel gas.

The second method of carbureting consists in the use of what is called a superheater, which is a circular or rectangular vessel, surrounded by sheet iron and lined with fire brick, and filled with pigeon holed work. The operation consists in passing the hot producer gas through this vessel; admitting, if necessary, a secondary supply of atmospheric air to effect the complete combustion of producer gas. By this means, the superheater is made red hot; and when the water gas is generated, it is passed through this vessel, and at the same time naphtha or oil is spread on the top of the producer or bottom or top of the superheater—depending upon the course the gas is made to take. This makes an illuminat

* Mr. Trewby must be incorrectly reported in respect to this.—ED. A. G. L. J.

ing gas of a permanent character, but not of such a constant or rich quality as by the first-named method, although the cost is apparently less. One advantage it possesses is that crude petroleum or "gas oil" can be used, which is inadmissible in the Tessie du Motay method.

The third process consists in carbureting the water gas in the cupola, without the use of a subsequent superheater. The operation consists in blowing up the cupola in the ordinary way; then, while the steaming is proceeding to make water gas, naphtha is introduced in several places round the circumference, and about two-thirds of the height of the incandescent fuel. Therefore the naphtha vapor would have to pass through one-third of the heated carbon in contact with water gas; and it is claimed that the same action takes place as with the use of a separate superheating vessel. Great care is exercised to keep the fuel at one regular height.

There is another process which differs very much from the foregoing. It is called the Jerzmanowski; and the object of the process is the reduction of the amount of carbonic oxide made. The operation is as follows: A fire-clay retort is set in an oven. It is filled with limestone, which is heated to redness. Steam and naphtha vapors are introduced into the mouthpiece of the retort, and passed up through the heated limestone, which decompose some portion of the carbonic oxide formed, substituting for it carbonic acid. Another modification of the same plan is by the use of a rectangular producer divided into two parts. The first half is filled with anthracite coal or coke, and the second with limestone. The heat is blown up in the usual way; and the producer gas passes down through the limestone. When gas is being made, naphtha is passed on to the top of the limestone at the rate of $1\frac{1}{2}$ to 2 gallons per minute. The effect of this method of working is to reduce the carbonic oxide from what it would be in the ordinary way—namely, 32 per cent.—to not more than about 20 per cent. This gas, which has an illuminating power of about 5 candles, is conveyed to a governing gas-holder, and brought back to the coal gas system of retorts to be carbureted in the same way as in the Tessie du Motay process first described. The process was originally introduced to meet the objection that has been raised to a large percentage of carbonic oxide, the reduction of which can only be effected by changing it into carbonic acid, which has no heating power, and exists as a diluent of the gas. It is claimed that the illuminating power is not appreciably lessened by leaving it in; a small extra amount of naphtha being sufficient to compensate for the deterioration in the illuminating power.

There is a process called the Meeze, which has been experimentally tried in New York, with very favorable results, for a period of fourteen months, and is now about to be tried by The Gas Light and Coke Company at one of their works. The apparatus consists of a circular retort, 18 inches in diameter, and 20 feet long, through the centre of which a cast iron pipe, about 6 inches in diameter, is led from one end to the other. The oil to be used, and superheated steam, are passed through this pipe to the extreme end of the retort, and find their way back between the pipe and the sides of the retort in contact with conical deflectors; and in this way a certain quantity of steam is taken up in combination with the oil, and made into a very rich gas. The water gas, manufactured in the ordinary way and already stored in a holder, is brought into contact with this gas, either in the retort or in the hydraulic main; the result being that a gas of 27-candle power is said to be produced. This process was brought out for the purpose of dealing with the heavy oils and petroleum, and is thought to be thoroughly suited for the Russian petroleum, which is very heavy, and contains but little naphtha. If anything is to be done in introducing water gas into this country to any large extent, it will probably be by means of the importation of Russian petroleum, which, as far as I can see, is likely to be delivered here at a cheaper rate than American oil, unless it be the Lima oil, which is found in the State of Ohio. This oil, however, contains a large quantity of sulphur. It must be understood that, in the manufacture of water gas, no alteration is required in the existing plant of a gas work. The only addition would be a cupola, and the necessary blowing apparatus for getting the fuel up to a state of incandescence.

I cannot close my account of the various processes I inspected without mentioning the cordial way in which I was received by the different gentlemen connected with the gas industry in America and Canada with whom I came in contact, and to whom I am greatly indebted for the amount of useful information I have collected.

THE new Lowe type of water gas apparatus recently installed on the Pottsville (Pa.) plant by the United Gas Improvement Company was started up about a fortnight ago. No hitch of any kind occurred at the initiation.

Paints and Painting for Iron Work.

Some time ago, in an article on "Paints," the *London Journal* remarked that whether the winds of the season breathe soft or biting, the approach of spring never fails to bring one sign of its presence beside lengthening days, and that is, the painter. Continuing, the commenter says:

It almost appears that the forcing process whereby the period of youth and immaturity has been abbreviated in many modern instances has extended to the years, and that spring is hurried over, not to make more room for summer, but to allow the artificial mist and gloom which exaggerate our winters to work out their full developments. Whether winds breathe soft or biting, however, what becomes of painters in the winter is a problem upon which other varieties of the British workman are wont to exercise a rough-and-ready wit; but it is certain that, whereas town residents learn through correspondence in the newspapers that those traditional harbingers of spring, the swallows and the cuckoo, have been seen and heard in country places, they might retaliate upon country cousins by naming as urban spring visitants the cheerful painter and his associate the whitewasher. Not only do town residences confess the presence of these busy visitors, making life so intensely wretched for anybody else who cannot get out of their way; but also in the grimmest factories painters are manufactured out of "handy men," and set to touch up iron and wood work stained and worn by the long winter's wear. The modern extension of the use of wrought iron and steel in place of the less perishable cast iron, has rendered the regular use of the paint brush imperative in places where it was formerly seldom seen. In gas works particularly, there is now much more wrought iron and steel than could have been found a generation earlier, and the consumption of paint has accordingly largely increased. The manufacture of paints for iron work is a very much more important industry than it used to be; but it is to be feared that in many cases increased excellence of the product has not accompanied the swelling of the trade. Of course it may be said, and with a great deal of truth, that the advance of knowledge in the matter of paint making has in some respects led to many improvements in the character of paints in general, and especially in regard to the preparation of paints for special purposes. Paints can now be bought that will cover and stand and preserve their colors when applied to purposes for which a few years ago painting was regarded as an unavailable means of protection. All the same, there is much truth in the reproach that when the application of chemistry to manufactures facilitated adulteration, it was in the paint, varnish, and oil trades that scientific sophistication found its favorite home.

Consideration of paints and painting is, as we have already said, seasonable just now; but it is also suggested by a paper of Professor V. B. Lewes, F. C. S., etc., read before the Institution of Naval Architects. The corrosion of iron ships is a subject which, regarded in its narrowest aspect, would not appear to specially interest gas engineers. Looking at ships as structures built of iron and steel, however, and only differing from other structures in the same materials by the severity of the corroding influences and strains to which they are exposed, it becomes clear that all who are interested in the preservation of these materials from the destroying influence to which they are naturally liable, must be able to draw valuable instruction from the experience of those who have to deal with these influences when manifested in their extreme rigor. Iron is perishable everywhere and under all ordinary conditions of use; but what will preserve the ironwork of a ship would, as one may reasonably conclude, preserve ironwork anywhere. It is this thought that impels us to devote some attention in these columns to Mr. Lewes's interesting paper.

The author does not set out with any claim to having made or heard of any new or startling discoveries in connection with his subject, but merely desires to keep the matter before the world of technical workers in iron and steel, in order that the ever-present importance of this particular quality of iron structures—perishability—should not be lost sight of. Professor Lewes has already done good service by pointing out in a paper read two years ago that in all processes of rusting, carbonic acid gas and moisture play an important part, the iron uniting with the carbonic acid and oxygen of the water to form ferrous carbonate, then taking up oxygen dissolved in the water, or present in the atmosphere, as the case may be, and decomposing into ferric oxide (rust) and carbonic acid, which being liberated in actual contact with the moist surface of the iron, carries on the process of "rusting." This view of the phenomena is confirmed by a paper read by Professor Crum-Brown before the Iron and Steel Institute in Edinburgh, and is generally accepted as the true explanation of the corrosion taking place on iron or steel surfaces

exposed to moist air or fresh water. The action of salt water on iron has been supposed by some chemists to involve a more complicated reaction; but Professor Lewes is persuaded that this is mythical, and that there is no essential difference between the rusting of iron in salt water and in fresh. Salt water, however, may, and probably does, set up a galvanic action between iron and any foreign substances in contact with it; but with this part of the question we are not particularly concerned. Any place where wet coal or carbon dust is brought in contact with iron, which is specially the case in gas works, is held by Professor Lewes to show speedy corrosion of the metal.

Dismissing metallic coatings of ironwork as unsatisfactory, Professor Lewes enumerates five divisions of non-metallic preservative coatings in common use. These consist of oil paints; pitch, asphalt, tar, or waxes; varnishes consisting of resins and gums dissolved in volatile solvents; varnishes containing substances to give them body; and coatings of cement. Before going into these in detail, he gave some necessary consideration to the condition of the surfaces to which they have to be applied. When an iron structure is scraped down to the bare metal, there is presented a huge surface which varies in temperature much more rapidly than the surrounding air. As it cools, so the iron chills the layer of air in immediate contact with it, and shows, by what is called "sweating," the deposition of surplus water on its surface, over which the protective coating has to be applied. If now a rapidly drying varnish is put on, the evaporation of the volatile solvent causes again a further loss of temperature, which brings another deposition of condensed moisture, this time on the surface of the protective, so that the coating is sandwiched between two layers of moisture, both of them probably acting deleteriously upon the resin or gum of the varnish, whilst the moisture on the iron also prevents adherence of the varnish to the metal. If instead of a quick-drying varnish a paint had been used, the second deposition would not have taken place; but the sweating of the iron would have prevented cohesion, and when dry, any rubbing of the coating would bring it off in strips. The condition of the skin of an iron structure, while the coating intended to protect it is being applied, is one of the prime factors in the observed discrepancies in the behavior of such compositions. Too much stress cannot be laid upon the condition of the surface of the iron at the time of coating; and it is perfectly essential either to have a dry surface or else a composition which is not affected by water. The author remarks that when an old iron structure is broken up, on the backs of the plates may often be seen the numbers painted on them in white lead and linseed oil when the work was put together, and under the paint the iron in a perfect state of preservation, the secret being that the paint was put on while the plates were hot and dry.

Compounds prepared with boiled linseed oil are, however, open to objection, on account of the presence of lead. The drying of boiled linseed oil is due to the fact of its containing a certain quantity of an organic compound of lead; and the drying property is moreover imparted by boiling it with litharge (oxide of lead), so that lead compounds are present even when the oil is not mixed with red or white lead pigment. When boiled oil dries, it does so by absorbing oxygen from the air, and becomes converted into a kind of resin, the acid properties of which also have a bad effect upon iron. Protectives of the class of tar and its derivatives, such as pitch and black varnish, and also asphalt and mineral waxes, are regarded by Professor Lewes as among the best. Certain precautions, however, must be taken in the case of tar and tar products, both of which are liable to contain small quantities of acid and of ammonia salts. If care is taken to eliminate these, and if it could be contrived to always apply this class of protectives hot to warm iron, the question of protection would be practically solved; bituminous and asphaltic substances forming an enamel on the surface of iron which is free from the objections to be raised against all other protectives—that is, of being microscopically porous and therefore pervious to water. Spirit or naphtha varnishes are condemned by Professor Lewes as open to several objections. Varnishes to which a body has been given by some pigment, generally a metallic oxide, are preferable to the last class, "if the solvent used is not too rapid in its evaporation, and if care has been taken to select substances which do not themselves act injuriously upon iron, or upon the gums or resins which are to bind them together, and are also free from any impurities which could do so."

At the present time, as the author truly remarks, the favorite substance for this purpose is the red oxide of iron; but care should be taken to exclude from it free sulphuric acid and soluble sulphates, which are common impurities and extremely injurious. The finest colored oxides are, as a rule, the worst offenders in this respect, as they are made by heating green vitriol (sulphate of iron), and in most cases the whole of the sulphuric acid is not driven off, the heat required being injurious to the color. The acid is often neutralized by washing the oxide with di-

lute soda solution; but very little trouble, as a rule, is taken to wash it free from the resulting sulphate of soda, which is left in the oxide. The best form of oxide of iron to use for paint making is obtained by calcining a good specimen of hematite iron ore at a high temperature. When prepared in this way it contains no sulphates, but a proportion of clay which is harmless if it does not exceed 12 to 18 per cent. Paint makers can easily test their red oxide for soluble sulphates by warming a little of it with pure water, filtering, and adding to the clear solution a few drops of pure hydrochloric acid and a little chloride of barium solution. If a white sediment forms in the solution the sample should be at once rejected.

In the application of a preservative coating to iron, Prof. Lewes directs, first, thorough scraping and scrubbing from all non-adherent old paint and rust. New iron should be pickled with dilute acid to get rid of every trace of mill scale; the acid to be neutralized afterwards by a slightly alkaline wash, and this again to be washed off by clean water. Under these conditions, and given a composition of good adhering properties, but little apprehension need be felt with regard to the ravages of corrosion, the chief remaining risks being from abrasion or other mechanical injury to the composition, coupled with improper constituents in itself. In conclusion, we have only to recognize the great care and knowledge with which Prof. Lewes has prepared his paper, which has been reprinted, and may be profitably consulted in detail by all who are in any way interested in the subjects of ironwork and ironwork paints.

SPECIAL ENGLISH CORRESPONDENCE.

COMMUNICATED BY NORTON H. HUMPHRYS.

SALISBURY, Jan. 10, 1890.

Gardner's Gas Globes.—The Rights of the Sweep.—Recent Strikes.—Dangers of Civilized Life.—Mr. G. C. Trewby on Water Gas.

Mr. D. R. Gardner, of Glasgow, has lately directed attention to a fact which has been pointed out in other ways on two or three occasions previously, but has not hitherto attracted the attention of gas consumers to any important extent. It is nevertheless a matter of great importance to all users of gas who wish to obtain the best possible value for their money. I allude to a principle first illustrated by Michael Faraday, about 50 years ago, by surrounding an ordinary argand gas burner with a cylindrical glass chimney about one inch or so larger in diameter. The air for the supply of the flame was thus caused to enter at the top of the outer chimney, and passing down the annular space between the two glass cylinders, became heated to a considerable degree before reaching the gas burner. The result was a great improvement in the "duty" obtained per cubic foot of gas used, and it was due to two causes. The first was a diminution in the quantity of air passing through the gas burner, and the second the heating of the air previously to reaching the flame. These two causes are both concerned in all endeavors to improve gas burners. In the modern regenerative burner it is usual to claim that a great advantage results from the heating of the air supply by means of some of the waste heat from the products of combustion. But a part of the benefit is undoubtedly due to the fact that the air supply, in following the tortuous course designed for it, is greatly diminished as compared with the supply of air that reaches an ordinary open flame. Just as a large excess of air admitted to a boiler furnace reduces the heating effect obtained from the fuel by taking away a part of the heat, so the large volume of air, rushing up the chimney of an argand burner, or through the openings of an ordinary globe, diminishes the flame temperature, and thereby causes a certain loss of light. Some few years since, Mr. Lewis T. Wright showed that by the simple expedient of a disc, the same diameter as the chimney, supported on the top by a cross bar and adjusting screw, the air supply could be adjusted to suit the quality of the gas consumed. The cap, in effect, is analogous to the damper of an ordinary furnace, and just as careful adjustment of the damper will economize the fuel, so attention to the air supply of the burner will economize the light. The same thing may be illustrated by introducing halfpence, one on the other, under the central opening in a Standard argand burner, and it is quite possible to increase the quality of the gas to the extent of a candle or two by this means.

Mr. Gardner applies this principle to ordinary globes in a very simple manner. He cuts a disc of asbestos sheet rather larger than the top of the globe, and fits on the under side three asbestos studs, each moving on an eccentric axis, for the purpose of accurately fixing the disc in contact with the top of the globe. At first it was found that the heat of the discs would cause the globes to break, but this objection was entirely overcome by the use of strips of mica between the disc and the globe. They act efficiently as a non-conductor. An opening about 1½ inches in

diameter is punched out of the center of the cover, and is covered by means of a circular piece of similar size, hinged on a pivot at one side, so that it can be turned to cover the hole, or to uncover it, to any desired extent. By turning the disc the air supply to the flame can be governed and adjusted so as to give the best result. Mr. Terrace, of the Tradeston gas works, Glasgow, has tried a series of experiments with this device and finds that it has the effect of improving the duty yielded by the gas to the extent of 20 to 30 per cent. Globes fitted with Mr. Gardner's simple arrangement ought, therefore, to find a ready sale.

An Irish newspaper publishes a complaint, presumably from a member of the sooty fraternity, as to the "unfairness" of the local gas companies in fixing gas stoves and so interfering with the business of chimney sweeping. No doubt the sweep has little ground for expecting an increase of business. People are slowly—very slowly—learning that it is better and cheaper to convert all the carbon into carbonic acid, and to secure the benefit of the heat thus evolved, than to deposit it in their flues as soot. The age of smokeless fuel will come, and it is not likely to be kept back by considerations of sympathy for the sweep, much less on account of anything in the way of vested interests in his business. His visits are regarded as a necessary nuisance, and would gladly be dispensed with. But owing to the slowness with which the public move in matters concerning their everyday welfare, he may count on no very great loss of business for many years yet.

The recent strikes of gas workers in Manchester, Salford, and London, offer a very large field for instruction. The experience thus gained leads to several conclusions of a general nature, useful to those who undertake the organization of labor disputes, beside those interesting to gas companies, with which we are specially concerned. It has shown that the business of gas making can be carried on, if need be, by ordinary, able-bodied laborers, under intelligent supervision, and that a matter of a fortnight or so is quite sufficient to make a fairly competent scoop driver or coke drawer of a raw recruit. In agitating for shorter hours of labor, the malcontents themselves have greatly aided this result, for it is only reasonable to suppose that a man unused to furnace work would become inured to exposure to heat with much greater facility on the eight hour, than on the twelve hour shift. The great stronghold of the stoker was not skill so much as strength and endurance. This has been broken into considerably by the reduction of hours of labor, and numerous other privileges so freely accorded by the companies, and I hear that men used to light labors only—clerks out of employ, hawkers and petty tradesmen, and such like—are able to undertake retort house work without discomfort. Another point unmistakably set forth is, that new hands take much more kindly to the scoop as compared with shovel charging. Some of this may be due to the fact that a badly charged retort is great trouble to an experienced rake hand, and of course much more so to a new beginner. But the chief lesson is the fact that in cases where the men have always been treated liberally, and no act of tyranny or oppression can be put forward as a cause for the strikers, the position of the employers is very strong, and that of the laborers is at a corresponding disadvantage. Had it been known that injustice of any kind was exercised toward the men, either at Manchester, Salford, or South London, the vacancies created by the continued withdrawal of the old hands would not have been so quickly filled up. The only chance of conducting a strike with any reasonable hope of success, is when a good case can be made out for public sympathy, or where, on account of special skill or other peculiarities of the work, the place of the strikers cannot be filled up. So far as the gas industry is concerned, it is to be hoped that the recent experience, disastrous as it has proved to many a steady and respectable working man, will not be without its use, as tending to promote a better understanding between employers and the employed. It may lead the latter to see that their masters are not necessarily their enemies, nor labor agitators their friends; whilst the former may reflect that payment of wage is not everything. The places referred to above are rather noted for kindness to the men than otherwise, but there are many employers of labor who need to be reminded that a little sympathy with the monotonous life of the toiler, a little endeavor in the way of brightening his colorless existence, is not thrown away.

The advance of civilization certainly increases our sorrows in one respect, and that is in regard to the various dangers that beset us on our way-through life. The latest public scare is that called the influenza epidemic, which is said to have raged all over Europe. The plain fact is that with the recent cold, damp, and extremely variable weather, coupled, perhaps, with the free living usually indulged in at this season of the year, has rendered ordinary catarrh more prevalent than usual of late. In gas circles a great deal of attention has been directed towards

the dangers of water gas, and also those of electricity. As usually happens in these cases, a great deal of exaggeration has occurred in both directions, and the main points at issue have been obscured or greatly distorted. One or two zealous individuals, roused by accidents that have come within the narrow range of their own personal experiences, have promulgated their views on the poisonous nature of water gas or of electricity, as the case may be, and being very scantily informed as to the principles of chemical and electrical science, have done more harm than good. Others, whose interests happen to be concerned, have hastily flown into print with a view of counteracting the effects of such statements on the mind of the public, and have proved too much. The accident at the Leeds forge, alluded to in my last letter, has been pronounced to be due to water gas. At the last moment the Company withdrew their attempts to account for it in other ways. But this accident is not sufficient to condemn water gas. Undoubtedly it is more poisonous than coal gas, just as a solution of arsenic containing 35 grains of that death-dealing element would be more poisonous than one containing only 7 grains. Yet both solutions might be safely used with the observance of proper precautions, and mixtures containing 20 or 30 per cent. of carbonic oxide might be distributed to the public as safely as ordinary coal gas, provided that the proper means were taken to guard against accident. The same considerations apply to electricity, the distribution of which is attended with special dangers. It is useless to deny the existence of such dangers, on the one hand, or to decry them as utterly unavoidable and without remedy on the other. Once let the principles underlying them be ascertained and clearly defined, and the precautions necessary to prevent them can readily be determined. Whilst deprecating recklessness, we must not run into the avoidance of every possible source of danger.

The current number of the *Journal of Gas Lighting* contains some interesting observations by Mr. G. C. Trewby, Chief Engineer of the Gas Light and Coke Company, on the information gathered during his recent visit to America, for the purpose of investigating the various water gas processes that are in operation in that country. He thinks that if anything is done in the way of introducing water gas into this country to any large extent, it will probably be by means of the importation of Russian petroleum, which is likely to be delivered in England at a cheaper rate than the American product, with the exception, perhaps, of Lima oil. Mr. Trewby acknowledges the cordial manner in which he was received by gentlemen connected with the gas industry, both in America and Canada, with whom he came in contact.

ITEMS OF INTEREST FROM VARIOUS LOCALITIES.

MR. JAMES C. LORD, who had been in charge of the Washington (Ind.) Gas Light Company's plant since March, 1877, has been appointed Superintendent of the Fort Worth Gas and Electric Light Company, Fort Worth, Texas. Mr. Lord is quite conversant with the electric light business, as the Washington Company was also engaged in the furnishing of electric currents. He is to be congratulated on his promotion to so large a field as Fort Worth certainly is, and his new employers are also to be congratulated on having secured such a competent man. We make no doubt that he will be fully up to the responsibilities of his new post, which will prove to be anything but the berth of a sinecurist.

MR. EDWARD P. GARTLAND, of the St. Louis Gas, Fuel and Power Company, has been named to succeed Mr. Lord at Washington, Ind.

MR. C. T. YERKES has been elected President of the Chicago (Ills.) Gas Light and Coke Company, vice Mr. Theobald Forstall. The First and Second Vice-Presidents chosen are C. R. Cummings and C. G. K. Billings respectively. The changes in the Board of Directors are the replacing of Messrs. Theobald Forstall, C. N. Fay, and W. W. Gibbs by Messrs. E. C. Benedict, Henry Fitzhugh, and F. S. Winston.

THE authorities of Rome, Ga., have determined to sell at auction shortly all the old gas lamps and posts that have been put out of service because of the adoption of electricity for illuminating the streets. Perhaps they would be doing about as well if they stored them for a while.

WE understand that Mr. Andrew C. Daniel, a member of the Board of Directors of the Consolidated Coal Company (St. Louis, Mo.) has purchased a controlling interest in the Danville (Ills.) Gas Light Company.

THE Edison Electric Illuminating Company, of Boston, has announced a reduction (to take effect Feb. 1) in the rate per hour for each 16-candle incandescent lamp. The new schedule calls for 1 cent per hour, as against the ruling one of 1½ cents per hour.

MR. HENRY SKILLMAN has been appointed Secretary of the Lexington (Ky.) Gas Company. By the way, what has become of the gentlemen who some months ago succeeded in inducing the City Council to grant them an ordinance for the operation of a fuel gas plant in this place?

AT the annual meeting of the Spencer (Mass.) Gas Company the following officers were chosen: President, Hon. Luther Hill; Vice-President, Hon. Geo. P. Ladd; Treasurer Richard Sugden; Secretary, Emerson Stone. The matter of raising the gas rate to \$1.50 per 1,000 (it is now \$1.25) was discussed, but the shareholders finally decided—and by unanimous vote—not to make any change. The average candle power of the gas sold by the Company during 1889 is returned at 20.70.

THE Directors of the Jefferson City (La.) Gas Light Company have declared a dividend of 2½ per cent. out of the earnings for the 6 months ended Jan. 1.

H. E. BYRON, Corporation Clerk of Linwood, Ohio, advertises for proposals for the lighting of 75 public lamps, hours of lighting same to be based on a moontable averaging 18 nights per month. Deodorized gasoline (74°) is to be the illuminating agent, and the bidder is to agree to keep the lamps "clean and in good repair." The contract is to run for 3 years, and the competition closes at noon of Friday next.

JUSTICE FURSMAN, of Troy, N. Y., on application of Judge Wilkinson has appointed Messrs. J. Irving Wendell, J. Crawford Green, and Geo. A. Stone, of Troy, appraisers to determine the value of 362 shares of stock in the old Troy Citizens Gas Light Company, held by Cornelius Callahan and others, of this city. Callahan refused to accept the price allotted the other shareholders when the terms for the consolidation of the three independent Troy gas companies were being arranged.

IN Circuit Court, before Judge Bartlett, a novel suit was brought by one John O'Brien, against the Manhattan Elevated Railway Company, plaintiff asking for damages for personal injuries in the sum of \$15,000. In presenting his case, counsel for plaintiff explained that O'Brien, in the performance of his labors for the Company—he was at the time of the accident hauling coal in cans to a platform in the structure owned by defendant, at the corner of Morris and Greenwich street—he had to step upon a single plank. Owing to insufficient light—it was early in the morning in the winter season—he slipped and fell, receiving injuries that resulted in gangrene of the lungs. From the evidence it was shown that the gas service pipe had been rendered temporarily useless because of "the gas being frozen therein." After testimony for plaintiff had been submitted, Mr. Ward, of counsel for defendant, moved to dismiss the case on the following grounds: The contributory negligence of the defendant; his acceptance of the risks attaching to his employment; the absence of proof of negligence on the part of the defendant, and that the accident was not of a nature for which the Company could be held blamable. After hearing counsel, Judge Bartlett said: The only negligence of which there is any proof at all is the failure of the defendant to keep the place properly lighted where the plaintiff was injured. Counsel for the plaintiff, upon the argument of this motion to dismiss the complaint, assert positively—what I am inclined to think the evidence shows, but they assume the position whether the evidence shows it or not—that this place where the accident occurred had always previously been sufficiently well lighted to enable the workmen there to do their work safely. As I have already suggested, the law does impose upon the master the obligation, which he cannot delegate or evade, of providing his servant with a safe and suitable place in which to do his work, or at all events, to use due diligence to make such provision. That obligation is generally, if not always, fulfilled by providing such a place as shall be safe and suitable in the first instance. I think that rule may be stated without any qualification, so far as premises or machinery are concerned, which are not apt to become dangerous simply by the lapse of time or the failure to inspect. So that this Company did their full duty to this employee and the others who were called upon to work in the same place, when they provided, so far as this case is concerned, suitable light at the point where the accident happened. That obligation they have fulfilled always up to the present time. I am unable to see how any negligence can be imputed to them, unless it is held either that they were bound to daily and almost hourly inspection of the gas there, which I think would be unreasonable, or unless some notice had been given to them of the dark condition of that part of the building. It does not appear to have come to anybody's attention that the place was dark until this man—very unfortunately, and we must assume, for the purpose of this motion, without any negligence on his part—suffered this injury. But we cannot shut our eyes to the fact that there are a great many accidents that are inevitable, or at all events for which nobody is to blame. I am inclined to think, on the evidence in this case, that the law does not hold the defendants liable; that they had fulfilled their obligation to keep the place properly lighted always theretofore; that they had no notice that it was dark on this occasion, and I cannot

see in the surrounding circumstances or in the lapse of time anything which ought reasonably to have put them upon such notice. For these reasons the motion to dismiss this complaint must be granted.

THE Citizens Gas Light Company (Newark, N. J.) has elected the following Directors: Messrs. A. A. Smalley, S. H. Condict, W. Clark, John L. Blake, C. A. Lighthipe, H. C. Kelsey, G. A. Halsey, Edmund L. Joy and H. Powles.

ACCORDING to the reports of the Gas Bureau (Phila., Pa.) the receipts for the year 1899 were \$3,658,224.83, and the expenditures, \$2,851,019.51, leaving a cash profit of \$807,205.32. The expenditures, however, included \$292,146.08 spent for extensions, so that the real profit from works operation was \$1,099,351.40. The receipts for the previous year were \$3,870,383.69, and included \$125,000 paid by the Schuylkill River East Side Railroad Company for damages to the Fifteenth Ward works. For the same time the expenditures were \$3,321,962.74. The receipts as compared with those of the preceding year were as follows: For gas, services, etc., at main office (1888), \$2,177,329.52; 1889, \$2,178,704.53. Spring Garden office (1888), \$869,174.72; 1889, \$903,922.02. Germantown office (1888), \$125,458.99; 1889, \$124,413.33. Frankford office (1888), \$62,803.10; 1889, \$61,812.18. Manayunk office (1888), \$46,586.71; 1889, \$46,486.65. For coke, tar, etc.: At Market street works (1888), \$218,544.08; 1889, \$170,322.69. Point Breeze works (1888), \$105,832.89; 1889, \$94,708.04. Manayunk works (1888), \$3,890.13; 1889, \$3,485.03. Richmond works (1888), \$130,603.10; 1889, \$56,501.31. For rents, repairs to mains, damages, etc., \$17,869.05. The falling off in the receipts from the sale of coke, tar, etc., is accounted for by the manufacture of water gas. A comparison of expenditures shows the following:

Account.	Year.	Amount.
For works.....	1888.....	\$128,568.32
" "	1889.....	276,386.39
For mains.....	1888.....	163,576.36
" "	1889.....	140,848.59
For services.....	1888.....	91,059.71
" "	1889.....	96,779.68
For gas.....	1888.....	2,120,011.73
" "	1889.....	1,654,772.85
For repairs.....	1888.....	273,088.87
" "	1889.....	273,689.55
For public lighting...	1888.....	157,809.32
" " "	1889.....	82,304.40
Miscellaneous.....	1888.....	386,848.43
"	1889.....	326,238.05

In addition to the gas sold, about 650,000,000 cubic feet were manufactured for and used by the city without cost, and if this were paid for at the rate of \$1.50 per 1,000 the receipt for the same would bring the total profit of the works up to \$2,074,351.40.

ONE of the local dailies, in commenting on these figures, believes the outcome is very creditable to Gen. Wagner's direction and Chief Park's supervision, and follows the encomium by remarking that "it (the report) demonstrates very clearly that the city would have been foolish to have sold the works a year or two ago at any price, much less at the price originally offered." The same authority also believes that as Gen. Wagner has met with so great a measure of success in carrying on the gas works bureau, a municipal electric lighting plant ought also to be installed and committed to his care.

IN the meantime it seems to us that if the figures submitted prove anything at all they are most potent in the line of showing that Philadelphia gas rates are altogether too high. Gas should be sold in that city certainly at a figure not in excess of \$1.25 per 1,000, with, say, 10 cents per M. off for prompt payment.

THE Brown estate holding (which comprised a majority of the shares) in the Madison (Wis.) Gas Light Company has been purchased by Western capitalists.

AMONG the recommendations submitted by the "Committee of 17," appointed some time ago to report desirable amendments to the city ordinances of Dunkirk, N. Y., is one to the effect that hereafter all gas and water services from street main to cellar wall lines shall be of leaden pipe.

AT the annual meeting of the Hartford City (Conn.) Gas Light Company the following Directors were elected: Messrs. John P. Harbison, F. B. Cooley, J. L. Howard, H. K. Morgan, George Roberts, Hugh Harbison, Atwood Collins, Nathaniel Shipman and Rodney Dennis.

THE Council of Fort Worth (Texas) has decided to accept the report from its sub-committee, which recommended that a municipal electric lighting plant be installed, at a cost not to exceed \$27,000. Arc and incandescent lamps are to be maintained—the Brush type to be employed for the former, the Edison being selected for the latter.

THE owners of the franchise for the establishment of a gas and electric lighting plant at Cicero, Ills., will erect the gas works this spring.

THE proprietors of the Niagara Falls (N. Y.) Gas Company have chosen the following officers: President, S. M. N. Whitney; Secretary and Treasurer, A. W. R. Henning. Directors, S. M. N. Whitney, Amos W. R. Henning, W. F. Evans, W. B. Rice, Benjamin Flagler, Francis R. Delano, E. E. Davis, J. Vedder and S. F. Symonds.

THE Phoenix, Arizona, gas works (built 3 years ago) comprises an oil gas plant of the type manufactured by W. Smith, of Pittsburgh. The daily capacity of the works is about 30,000 cubic feet; the holder capacity is equal to 66 per cent. of the maximum make; the main mileage is 1½, and 12 street lamps are paid for by the authorities. The works cost \$30,000. The officers are: President, N. C. Parsons; Vice-President and Treasurer, J. H. White; Secretary, A. P. Wade; Superintendent, H. Ohnick.

THE Directors of the Peoples Gas Light Company (Cleveland, O.) have named the following executive management: President, Geo. H. Warmington; Secretary and Treasurer, Julius M. Carrington; Supt. and Engineer, Edward Lindsley; Asst. Supt., Daniel Warmington.

THE following are the bids submitted in response to the invitation of the authorities for tenders for the public lighting of Clinton, Iowa:

Bidder.	No. of Nom. 2,000 c. p. Arcs.	Actual Candle Power.	No. Incan. Lights 32 c. p.	No. Incan. Lights 25 c. p.	Price per Light per Annum.
Excelsior Electric Co. (burn all and every night).....	any	1,600	\$90 00
Clinton Gas Lt. & Coke Co. (all night P. G. and M. T.)	45	700	75 00
Clinton Gas Lt. & Coke Co.	200	20 00
Clinton Gas Lt. & Coke Co.	225	18 00
Brush Electric Co. (burn all night P. G. and M. T.)....	50	130 00
Brush Electric Co. (burn all and every night).....	50	142 50
Schuyler Electric Co. (burn all and every night).....	75	150 00
Fort Wayne Electric Co. (burn all and every night)	50	1,700	137 50
Fort Wayne Electric Co. (all night P. G. and M. T.)	50	125 00
Fort Wayne Electric Co. (on nights dark by clouds)....	50	130 00
Keystone Const. Co. (burn all night P. G. and M. T.)	20	700	78 00
Keystone Const. Co.	75	22 00
Keystone Const. Co.	75	20 00

THE following letter holds several good hints:

TONAWANDA, N. Y., Jan. 18, 1890.

To the Editor AMERICAN GAS LIGHT JOURNAL: It is with pleasure and interest that your valuable issues of gas items, appearing from time to time, are perused, the reader extracting therefrom good and valuable information. As yet, however, I have seen nothing to "elevate" and do justice to one of the most important accessories of our business, viz., the much abused and condemned gas meter—innocence and purity are fully stamped on its face. A silent, just and honorable calling it has to perform; and as a just monitor between man and man it should be justly treated and respected. Yet, when placed in a building, some dark, out-of-the-way corner is selected for its location—"out of sight, out of mind," seems to be the custom. Consumers should for their own protection have their meters in convenient and accessible places. By so doing the consumers can easily read their meters and control the flow of gas, thus helping the faithful meter taker in the prosecution of his duties.—METER.

THE proprietors of the Tonawanda (N. Y.) Gas Light Company are now about to enjoy the fruits of their intelligent scheme of reorganization, that was perfected some two years ago, and there can be little doubt that a good round dividend rate will soon be their reward. The rates

for gas, determined on the first of the year, and which are to rule for the present, are:

Monthly Consumption.	Net Rate per 1,000.
4,900 cu. ft. and under....	\$1.50
5,000 " to 15,000 cu. ft.....	1.40
15,000 " and over.....	1.25

Street lamps for public lighting are supplied at the very low rate of \$18 per post, on an all night burning table. These rates are surely of the liberal sort, and cannot fail to tell in the increasing prosperity of the Company.

MR. GEORGE SHEPARD PAGE, of this city, sends the following greeting to the fraternity:

HOTEL METROPOLE, MONTE CARLO, Jan. 7, 1890.

Dear Mr. Editor:—Possibly some of the readers of the JOURNAL, as well as yourself, will be interested to know that Mrs. McMillin, with her two daughters and son, as well as Mrs. Page and the writer, are spending some days in this most delightful winter resort. Mrs. Page and I were in Rome during the Holidays. Mr. McMillin's family are to remain abroad for a year. Miss Stella McMillin will during that time be under the instruction of the famous Madame Lagrange, in Paris, perfecting the training of her already remarkable voice—a pure soprano.

Mrs. Page and I return to London towards the close of January. Notwithstanding a severe attack of influenza experienced in Rome, I am being greatly benefited by the needed rest from most active attention to business for the three past years. * * *

Wishing you all, and my many friends among your patrons, a happy and prosperous New Year, I remain,

Sincerely yours, GEO. SHEPARD PAGE.

THE enterprising proprietors of the Alton (Ills.) Gas and Electric Light Company have made many improvements on their establishment. The office quarters have been renovated and renewed. An automatic governor has been placed, and the new bench of retorts is equal to the work that was expected from it. Supt. Tracy also informs us that an additional dynamo will be placed in the electric annex at an early date in the spring. He will also make a determined effort to popularize the use of gas for cooking and heating, and if his success at Alton will be like that obtained by him at Peru, Ind. (his old post of duty), a marked increase in day output will be the result.

AT the annual election of the Williamsport (Pa.) Gas Company the following result was reached: President, Hon. Joseph M. Gazzam; Secretary, Treasurer and Superintendent, C. A. Byers; Assist. Supt., M. J. Winters; Solicitor, Jas. G. Reading, Jr.; Collector, Jas. Calvert. Directors, the Hons. Jos. Gazzam, R. P. Allen and R. J. C. Walker, and Messrs. H. Mudge, John G. Reading, Jr., B. C. Bowman and John G. Reading.

MENTION of the election at Williamsport brings to mind one result of *la grippe* at that point. About a fortnight ago (the trouble lasted for two days) the people complained of bad gas, and the reason therefor was the sudden prostration, by an attack of influenza, of the working force in the purifying house.

A STILL more remarkable instance of the power of this unwelcome visitor is shown in the fact that the annual meeting of the stockholders in the Newport (R. I.) Gas Light Company (set for the 13th of January) had to be postponed for a fortnight—so many of the stockholders were suffering from the influenza that a quorum could not be gathered together at the appropriate time.

THE following Directors were chosen at the annual meeting of the Brooklyn (N. Y.) Gas Light Company: H. D. Polhemus, H. K. Shelton, A. M. White, Jas. H. Armington, H. H. Rogers, G. H. R. Lyman, A. E. Orr and W. Cary Sanger. We understand that Mr. Sanger has been elected to the Presidency.

THE Mansfield (Mass.) Gas and Electric Light Company has been incorporated by a score of local capitalists. Its President is A. F. Rogerson, and W. C. Winter is its Clerk and Treasurer. It is proposed to commence construction work on the gas plant next March. This place is in Bristol county, Mass., at a point 24 miles south and west of Boston, and 20 miles north, northeast of Providence, R. I. It is quite a manufacturing center—cutlery, straw goods, furnaces, spindles, etc.—and has a population of perhaps 5,500.

THE family of the laborer Guthrie, who was killed in the explosion at the Asheville gas works, have brought suit against the Company for \$25,000 damages.

Advertisers Index.

GAS ENGINEERS.		Page
Jos. R. Thomas, New York City	124	
Wm. Henry White, New York City	129	
Wm. Mooney, New York City	124	
William Gardner, Pittsburgh, Pa.	124	
Fred. Bredel, N. Y. City	123	
GAS AND WATER PIPES.		
Gloucester Iron Works, Phila., Pa.	124	
Mellert Foundry and Machine Co., Reading, Pa. (John Fox, Selling Agent, N. Y.)	124	
Ohio Pipe Co., Columbus, Ohio	124	
M. J. Drummond, New York City	124	
R. D. Wood & Co., Phila., Pa.	126	
Warren Foundry & Machine Co., New York City	124	
Donaldson Iron Co., Emaus, Pa.	124	
Dennis Long & Company, Louisville, Ky.	124	
GAS WORKS APPARATUS AND CONSTRUCTION.		
James R. Floyd & Sons, New York City	127	
Continental Iron Works, Greenpoint, L. I.	127	
Delly & Fowler, Phila., Pa.	127	
Kerr Murray Mfg. Co., Fort Wayne, Ind.	115	
Stacey Mfg. Co., Cincinnati, Ohio	127	
Bartlett, Hayward & Co., Baltimore, Md.	125	
Morris, Tasker & Co., Limited, Phila., Pa.	125	
Davis & Farnum Mfg. Co., Waltham, Mass.	83	
R. D. Wood & Co., Phila., Pa.	126	
Bouton Foundry Co., Chicago, Ills.	127	
Smith & Sayre Manufacturing Co., New York City	127	
Fred. Bredel, N. Y. City	123	
United Gas Improvement Co., Phila., Pa.	117	
Henry Pratt & Co., Chicago, Ill.	123	
National Gas Light and Fuel Co., Chicago, Ills.	118	
Slmpkin & Hillyer, Richmond, Va.	113	
PROCESSES.		
National Gas Light and Fuel Co., Chicago, Ills.	118	
Bartlett, Hayward & Co., Baltimore, Md.	125	
Wm. Henry White, N. Y. City	129	
United Gas Improvement Co., Phila., Pa.	117	
Henry Pratt & Co., Chicago, Ill	123	
INCLINED RETORTS.		
Laclede Fire Brick Manuf'g Co., St. Louis, Mo.	115	
GASHOLDER TANKS.		
W. C. Whyte, New York City	118	
J. P. Whittier, Brooklyn, N. Y.	113	
GASHOLDER PAINT.		
The Government Waterproof Paint Co., Boston, Mass.	113	
RETORTS AND FIREBRICK.		
J. H. Gautier & Co., Jersey City, N. J.	122	
B. Kreischer & Sons, New York City	122	
Adam Weber, New York City	122	
Laclede Fire Brick Manuf'g Co., St. Louis, Mo.	122	
Brooklyn Retort and Fire Brick Works, Brooklyn, N. Y.	122	
Borgner & O'Brien, Phila., Pa.	122	
James Gardner, Jr., Pittsburgh, Pa.	122	
Henry Maurer & Son, New York City	123	
Chicago Retort and Fire Brick Co., Chicago, Ills.	122	
Baltimore Retort and Fire Brick Co., Baltimore	122	
Oakhill Gas Retort and Fire Brick Co., St. Louis, Mo.	122	
SCRUBBERS AND CONDENSERS.		
G. Shepard Page, New York City	116	
R. D. Wood & Co., Phila., Pa.	126	
REGENERATIVE FURNACES.		
Bartlett, Hayward & Co., Baltimore, Md.	125	
Fred. Bredel, New York City	123	
Chicago Retort and Firebrick Co., Chicago, Ills.	122	
Wm. Henry White, N. Y. City	129	
J. H. Gautier & Co., Jersey City, N. J.	123	
GAS GOVERNORS.		
Connelly & Co., New York City	119	
Fred. Bredel, N. Y. City	123	
Friedrich Lux, London, England	112	
SELF-SEALING MOUTHPIECE DOORS.		
Smith & Sayre Mfg. Co., New York City	123	
TAR AND CARBONIC ACID EXTRACTOR.		
Geo. Shepard Page, N. Y. City	84	
PURIFYING MACHINES.		
C. & W. Walker, London, England	18	
CEMENTS.		
C. L. Gerould & Co., Brooklyn, N. Y.	122	
GAS ENRICHERS.		
Standard Oil Co., Cleveland, Ohio	128	

GAS METERS.	
John J. Griffin & Co., Phila., Pa.	130
American Meter Co., New York and Philadelphia	131
The Goodwin Gas Stove and Meter Co., Philadelphia, Pa.	131
Helme & Mellhenny, Phila., Pa.	131
D. McDonald & Co. Albany, N. Y.	131
Nathaniel Tufts, Boston, Mass.	130
Maryland Meter and Manufacturing Co., Baltimore, Md.	98
John Hillen, Brooklyn, N. Y.	130

EXHAUSTERS.	
P. H. & F. M. Roots, Connerville, Ind.	126
Smith & Sayre Manufacturing Co., New York City	127
Wilbraham Bros., Philadelphia, Pa.	119
Connelly & Co., New York City	119

GAS COALS.	
Penn Gas Coal Co., Phila., Pa.	129
Perkins & Co., New York City	128
Newburgh Orrel Coal Co., Baltimore Md.	129
Despard Coal Co., Baltimore, Md.	129
Chesapeake and Ohio R. Coal Agency, N. Y. City.	129
Westmoreland Coal Company, Phila., Pa.	129
J. & W. Wood, New York City	128

CANNEL COALS.	
Perkins & Co., New York City	128
J. & W. Wood, New York City	128

VALVES.	
Ludlow Valve Manufacturing Co., Troy, N. Y.	120
John McLean, New York City	120
Chapman Valve Manufacturing Co., Boston, Mass.	120
R. D. Wood & Co., Phila., Pa.	126

GAS ENGINES.	
Schlelecher, Schumm & Co., Phila., Pa.	152
Clerk Gas Engine Co., Phila., Pa.	120
Van Duzen Gas Engine Co., Cincinnati, Ohio	120

ENGINES AND BOILERS.	
Jarvis Engineering Co., Boston, Mass.	119
Ball Engine Co., Erie, Pa.	113
Westinghouse Machine Co., Pittsburg, Pa.	119

GAS LAMPS.	
G. Shepard Page, New York City	88
Standard Gas Lamp Co., Phila., Pa.	113
Welsbach Incandescent Gas Light Co., Phila., Pa.	114
The Siemens-Lungren Company, Philadelphia, Pa.	114

PURIFIER SCREENS.	
John Cabot, New York City	120
Bartlett, Hayward & Co., Baltimore, Md.	120

GAS STOVES.	
American Meter Co., New York and Philadelphia	121
The Goodwin Gas Stove and Meter Co., Phila. Pa.	100
George M. Clark & Company, Chicago, Ills.	120

STREET LAMPS.	
J. G. Miner, Morrisania, New York City	113
Bartlett Street Lamp Man'g Co., New York City	113

BURNERS.	
C. A. Gefroerer, Phila., Pa.	128

STEAM BLOWER FOR BURNING BREESE.	
H. E. Parson, New York City	120

PURIFYING MATERIAL.	
Connelly & Co., New York City	119
Friedrich Lux, London, England	112
Edgewater Lime Works, Edgewater, N. J.	112

COKE CRUSHER.	
C. M. Keller, Columbus, Ind.	129

ELECTRICAL APPARATUS.	
Wm. Henry White, N. Y. City	129

SOLVENTS.	
Maas & Waldstein, New York City	113

Position Wanted
As Superintendent or Assistant,
 Or Inspector of Meters, and all outside and inside work. Has had many years' experience; ten years in last employ. Best of references. Address 764-I "W. A.," care this Journal.

FOR SALE.
A Complete Water Gas Plant.
60,000 Cu. Ft. Daily Capacity.
 Fully equipped; all the latest improvements; Includes Generator, Purifiers, and Holder. Can be removed to any part of the country, and set up at small cost. For further information apply to BRADFORD GAS LT. & HEATING CO., Dunkirk, N. Y.

FOR SALE,
One 5-ft. Station Meter.
One Hydraulic Main (five sections), wrought iron, 22 by 24, with Bye-Pass on Dip-Pipes.
25 Valves, Stand-Pipes, 7-inch Mouthpieces and Lids, all complete, ready for use, to fit up five benches of 5's.
 This apparatus is all in first-class condition.
Price, \$800, f.o.b. cars or boat, Poughkeepsie, N. Y.
 Inquiries may be sent to this Office.

GAS WORKS FOR SALE.
 A CONTROLLING INTEREST IN SEVERAL
Interior California Coal Gas Plants,
 now paying handsomely, are offered on very reasonable terms. This is an exceptionally good opportunity for practical gas men of limited means, wishing to remove to a mild and healthful climate, to acquire an established and paying business. Particulars given and full investigation solicited.
 SECRETARY, 123 Beale Street,
 San Francisco, Cal.
 760-1f

Fuel and Its Applications.
 By E. J. MILLS, D.Sc. F.R.S., and F. J. ROWAN, C.E., assisted by others, including Mr. F. P. Dewey, of the Smithsonian Inst., Wash., D. C.
 7 PLATES, AND 607 OTHER ILLUSTRATIONS. ROYAL OCTAVO, PAGES XX, 802. HANDSOME CLOTH, \$7.50.
A. M. CALLENDER & CO., 42 Pine St., N. Y.

GEROULD'S
System Gas Bookkeeping.
Approved and adopted by many of the prominent Gas Engineers of the Country.
 Sample Sheets and Price-List furnished free on application to
L. P. GEROULD, - - Mendota Ill.

EDGEWATER LIME WORKS
Chas. F. McKenna, Proprietor.

SHELL LIME.
 Lime by the Cargo for Gas Purification.
EDGEWATER, BERGEN CO., N. J.
 Write for Testimonials and Prices.

FRIEDRICH LUX,
 Ludwigshafen am Rhein and London.
Lux Mass
GAS GOVERNORS,
Gas Balance.

6 PER CENT.

First Mortgage Bonds

ON GAS WORKS

SITUATED IN GROWING WESTERN TOWNS.

Principal and Interest Guaranteed.

INTEREST SEMI-ANNUALLY.

For sale by the undersigned, who will furnish all necessary information regarding them.

JOS. R. THOMAS, 42 Pine St., N. Y. City.

PATENTS.

FRANKLIN H. HOUGH

Solicitor of American & Foreign Patents.

925 F. ST., WASHINGTON, D. C.

(NEAR U. S. PATENT OFFICE.)

Personal attention given to the preparation and prosecution of applications for Letters Patent. All business before the U. S. Patent Office attended to for moderate fees. **No Agency in the United States possesses superior facilities for obtaining Patents**, or for ascertaining the patentability of inventions. Copies of patents furnished for 25 cents each. Correspondence solicited.

Simpkin & Hillyer

RICHMOND, VA.

MANUFACTURERS OF

Gas Works Apparatus

BENCH CASTINGS, CONDENSERS, Scrubbers, Purifiers, Dry Center Seals, FOUR-WAY VALVES, GAS VALVES, SULPHATE OF AMMONIA APPARATUS, TANKS, ENGINES, BOILERS, PUMPS, ETC., ETC.

Plans, Specifications and Estimates furnished for new works, or alteration of old works. Correspondence solicited. Works, Newport News, Va.

Bartlett Street Lamp Mfg. Co.

MANUFACTURERS OF

Globe Lamps,

FOR

Streets, Parks, Public Buildings, Railroad Stations, etc.

LAMP POSTS

A Specialty.

Office and Salesroom,

40 & 42 COLLEGE PLACE, - - N. Y. CITY.

Gas Companies and others intending to erect Lamps and Posts will do well to communicate with us.

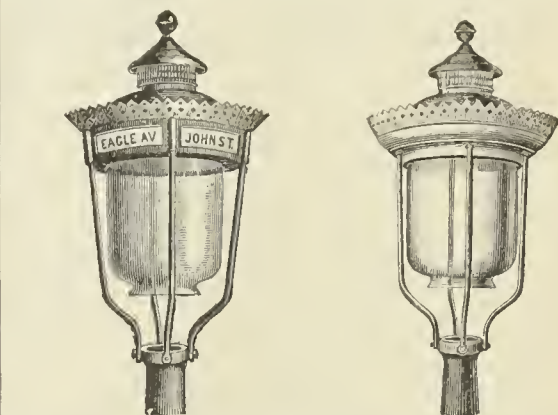

The Miner Street Lamps.

Jacob G. Miner,

No. 823 Eagle Ave., New York, N. Y.

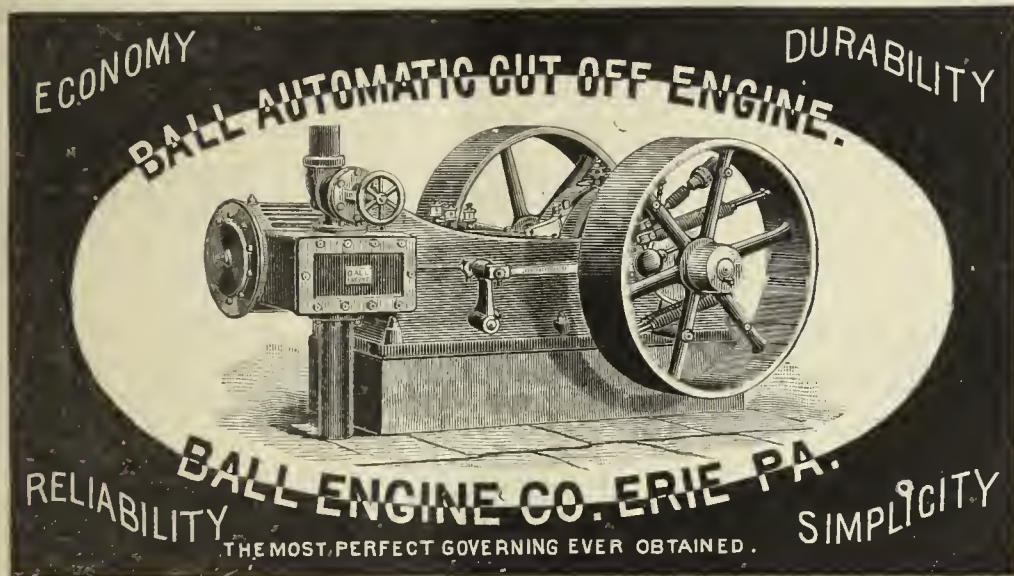

PHILADELPHIA.

NEW YORK.

CHICAGO.

STEPHEN A. MORSE, President.
GODFREY REBMANN, Vice-Pres.

EDWIN F. MORSE, Secretary.
CARLTON M. WILLIAMS, Treas.

STANDARD GAS LAMP CO.,

Main Office, 411 Cherry St. Factory, 1101, 1103, 1105 Frankford Av.

PHILADELPHIA, PA.

It is to the interest of Gas Companies and Cities to double the efficiency of the light on streets by using Dyott's Patent "CHAMPION" LAMPS. They save 50 per cent. over others in cost of repairs, are ornamental, and indestructible except by violence.

Our Patent System of Instantaneously Lighting Gas (without electricity), for Railroad Depots is unequalled.

Dyott's High Candle Power Burner is a very superior lamp where a concentrated and brilliant light is wanted in Hotels, Stores, Depots, etc.

Special Drawings furnished and Estimates cheerfully given, either from Architects', Engineers', or our Draughtmen's Plans.

We manufacture every description of Plain and Ornamental Lamps, Posts, Brackets, Clusters, etc. Correspondence solicited.



No. 29 Champion.



Standard Street Lamp

GASHOLDER PAINT.

Use Only

THE GOVERNMENT WATERPROOF PAINT.

Proof against Ammonia, and Absolutely Waterproof. Send for Prices and Particulars.

THE GOVERNMENT WATERPROOF PAINT CO., 122 Milk Street, Boston, Mass.

(Patented.)

IMPORTANT!

(Patented)

NEW SOLVENT FOR GAS PIPE DEPOSITS.

Economical and Effective.

MAAS & WALDSTEIN, 44 Trinity Place and 81 Greenwich St., N. Y.

Gasholder Tanks & Gas Works Masonry Complete.

PLANS PREPARED AND ESTIMATES FURNISHED AT SHORT NOTICE.

J. P. WHITTIER, - - 499 Wythe Av., Brooklyn, N. Y.

The Gordon Portico Lamp.

A successful Competitor of the Arc Electric Light for lighting Store Fronts, Show Windows, Depots, Railway Sheds, etc., etc.

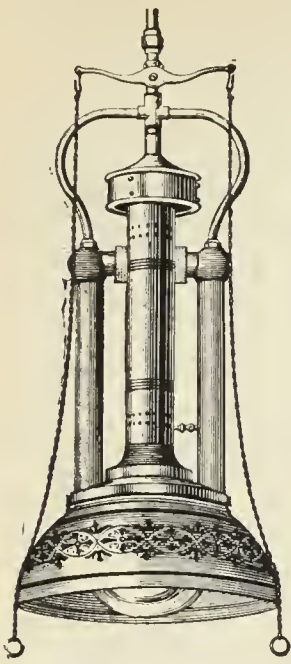

Gordon Portico Lamp.

The Gordon Street Lamp.

A Successful Competitor of the Arc Electric Light for lighting Streets, etc., etc.

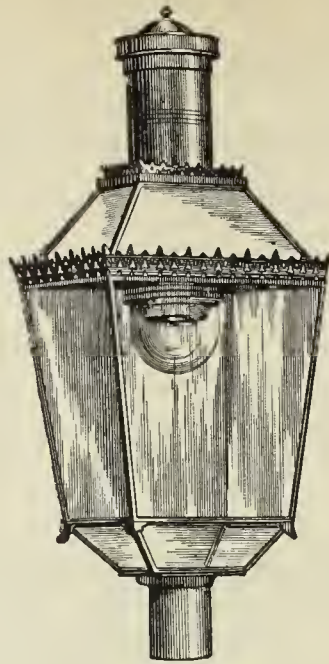

Gordon Street Lamp.

The Lungren Lamp.

A Successful Competitor of the Incandescent Electric Light for Interiors, etc. Is especially applicable for the lighting of Offices, Stores, Factories, Mills, Show Windows, Libraries, and all situations where an increased illumination is desired.

More than 25,000 Lungren Lamps are now in use. Testimonials, references, or any desired information will be cheerfully given.

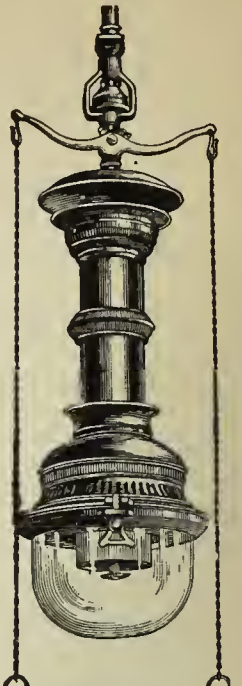

Lungren Lamp.

THE SIEMENS-LUNGREN CO., N.E. Cor. 21st St. & Washington Av., PHILADELPHIA.

WELSBACH SYSTEM OF Incandescent Gas Lighting.

OFFICE, DREXEL BUILDING, PHILA., PA.

At the Fall Session of the Board of Supervisors of Winnebago County, held at the County Court House, Oshkosh, Wis., Nov. 26, 1889, the report submitted by Mr. C. W. Cook, Chairman of the Committee on Public Buildings, recommending the use of the Welsbach Incandescent Gas Burner in the Buildings under their charge, was unanimously adopted, because of the extreme economy in the consumption of Gas and the superior character of the light obtained.

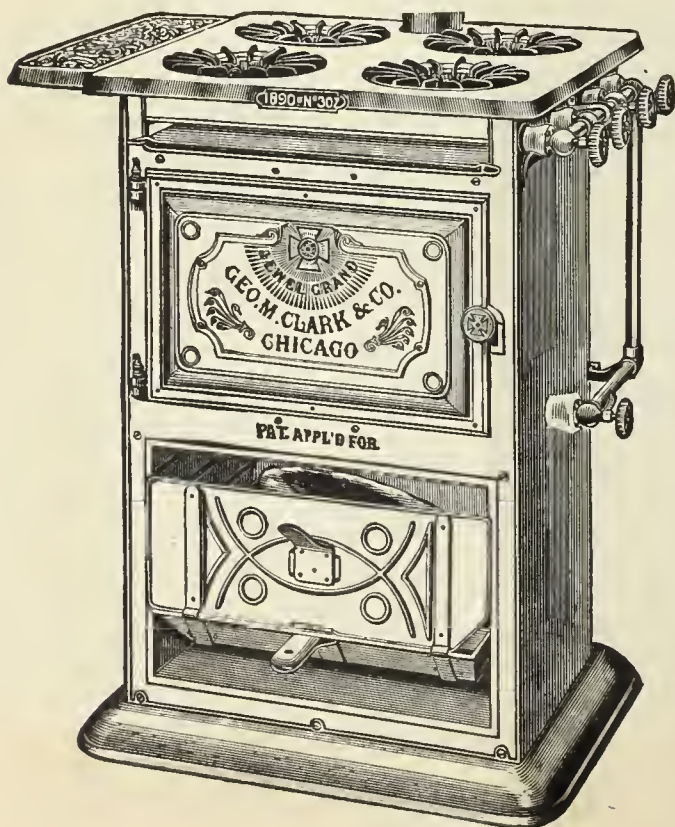

JEWEL GAS STOVES

MANUFACTURED BY

GEORGE M. CLARK & COMPANY,

Nos. 157 & 159 Superior Street, - - - Chicago, Ill.

EVERY CONCEIVABLE SIZE AND STYLE,

Ranging in Prices from \$1.50 to \$30.00.

WE USE NO GAS COCKS.

All Flames are Regulated by a Direct Needle Valve.

The JEWEL

IS THE

Only Well-Made Gas Stove on the Market.

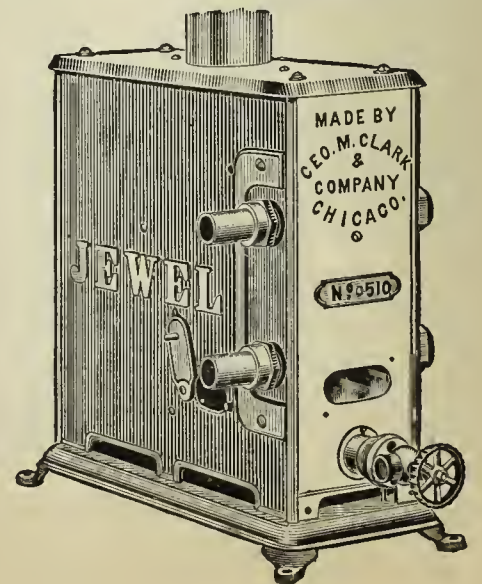

Write for our 1890 Catalogue and see for yourself.

THIS SPACE
 WILL BE
 Occupied Next Month by the
KERR MURRAY MFG. CO.
 FORT WAYNE, IND.
**GAS WORKS
 APPARATUS
 AND
 HOLDERS.**

LACLEDE FIRE BRICK MANUFACTURING COMPANY,

ST. LOUIS, MO.

Exclusive Agents in the United States

FOR THE

Coze System of Inclined Retorts.

IT IS THE COMING BENCH
FOR MAKING COAL GAS.

*It will Save from 50 to
60 per ct. in Labor.*

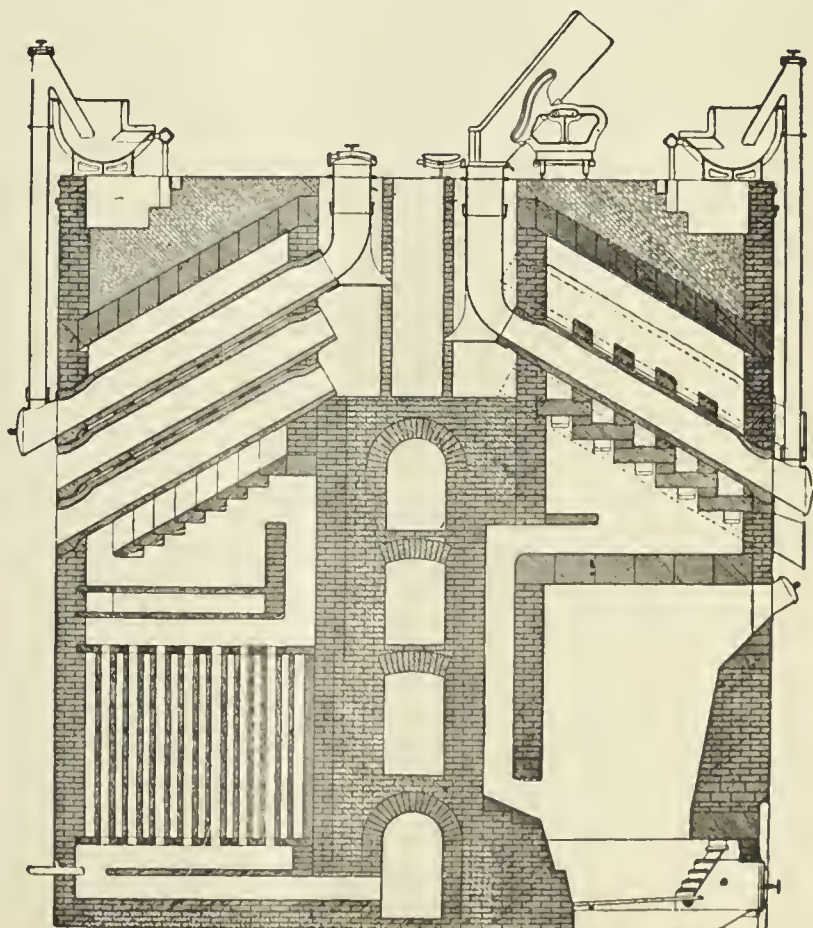
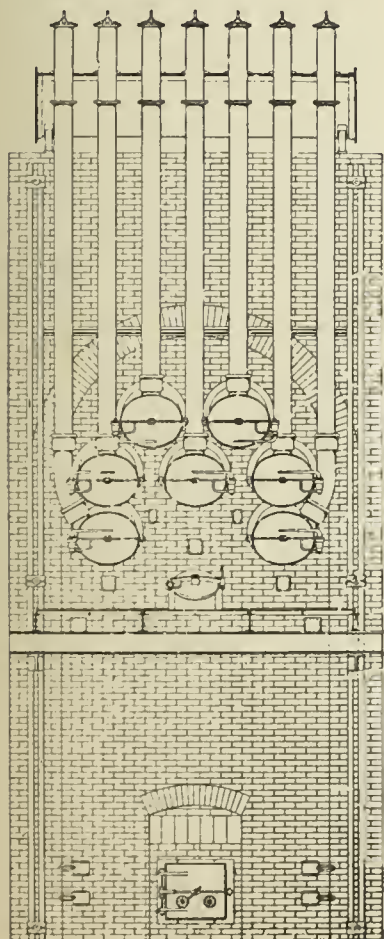

ESTIMATES AND PLANS FURNISHED BY THE

LACLEDE FIRE BRICK MFG. CO., ST. LOUIS, MO.

KIRKHAM, HULETT & CHANDLER, LIMITED.

PATENT "STANDARD" WASHER-SCRUBBERS

Erected and in course of construction at present date:

Capacity. Cubic feet per day.	Capacity. Cubic feet per day.	Capacity. Cubic feet per day.	Capacity. Cubic feet per day.
Altrincham..... 600,000	Dublin..... 3,000,000	LONDON—Continued.	Ober Schlesian..... 1,500,000
Adelaide..... 600,000	Dowlais..... 100,000	Shoreditch..... 2,500,000	Otto & Co.'s Coke Works..... 1,500,000
Aldershot..... 200,000	Douai..... 500,000	Pancras..... 1,500,000	Plymouth..... 2,000,000
Allegheny, U. S. A. 1,000,000	Denton..... 500,000	"..... 1,500,000	Parramatta, N. S. W..... 100,000
Ashton-under-Lyne..... 1,250,000	Derby, U.S.A. 350,000	Pimlico..... 2,000,000	Prescott..... 150,000
Amsterdam..... 1,500,000	Denver, " 500,000	Nine Elms..... 3,000,000	Providence, U.S.A. 750,000
"..... 1,500,000	"..... 1,000,000	"..... 3,000,000	"..... 750,000
Annaberg..... 200,000	Dusseldorf..... 750,000	South Metropolitan Co:—	Plauen..... 300,000
Arcachon..... 100,000	"..... 500,000	Greenwich..... 3,000,000	"..... 300,000
Animal Charcoal Co..... 200,000	Dumfries..... 250,000	Woolwich..... 400,000	Portsmouth..... 2,500,000
Altoona, U.S.A. 350,000	Dunedin, N.Z..... 400,000	Vauxhall..... 3,000,000	"..... 2,500,000
Buxton..... 250,000	Darlington..... 1,250,000	"..... 3,000,000	Pittsburgh, U.S.A. 1,500,000
Bradford..... 1,000,000	Detroit, U.S.A. 750,000	Lea Bridge..... 300,000	Portland, " 560,000
"..... 1,250,000	Edinburgh..... 1,500,000	West Ham..... 1,500,000	Pawtucket, " 500,000
"..... 1,250,000	"..... 2,000,000	Leeds..... 2,000,000	Quebec 250,000
"..... 1,250,000	Enfield..... 300,000	"..... 3,000,000	Radcliffe..... 750,000
"..... 1,000,000	Essen..... 300,000	"..... 3,000,000	Rouen..... 250,000
"..... 1,000,000	Elbing..... 150,000	"..... 3,000,000	Ramsgate..... 1,000,000
"..... 3,000,000	Falmouth..... 150,000	"..... 3,000,000	Reigate..... 200,000
Bremen..... 150,000	Frankfort..... 300,000	"..... 3,000,000	Richmond, U.S.A. 250,000
Baltimore, U.S.A. 1,000,000	Farnworth..... 400,000	"..... 3,000,000	Roxbury, " 500,000
"..... 1,000,000	Fenton..... 400,000	"..... 2,000,000	Runcorn Soap Co..... 20,000
"..... 1,000,000	Friedenshutte..... 500,000	Leominster..... 150,000	Rockhampton, N. S. W..... 125,000
Balmain, N.S.W..... 125,000	Furth..... 400,000	Leiden..... 560,000	Richmond..... 1,500,000
Bishops Stortford..... 150,000	Freiburg..... 200,000	"..... 600,000	Reading..... 2,000,000
Blackpool..... 400,000	Goole..... 250,000	Liverpool..... 2,000,000	Reichenbach..... 200,000
Brussels..... 1,250,000	Glossop..... 300,000	"..... 2,000,000	Salford..... 1,750,000
"..... 1,250,000	Guildford..... 300,000	"..... 2,000,000	"..... 1,750,000
"..... 750,000	Gloucester..... 1,250,000	"..... 2,000,000	Smethwick..... 750,000
"..... 1,250,000	Gera..... 300,000	"..... 2,000,000	Sydney, N. S. W..... 1,000,000
Banbury..... 250,000	Grafton, N.S.W..... 100,000	"..... 2,000,000	"..... 1,000,000
Birmingham..... 5,000,000	Grieg..... 300,000	"..... 3,000,000	"..... 2,500,000
Birkenhead..... 2,500,000	Georgetown, U.S.A. 250,000	Lincoln..... 1,000,000	"..... 50,000
Blackburn..... 1,500,000	Gluckauf..... 200,000	Lowell, U. S. A..... 1,000,000	Sunderland..... 1,500,000
Bochum..... 600,000	Heywood..... 600,000	Louisville 1,500,000	St. Josephs, U.S.A. 250,000
Burntisland..... 250,000	Hollywood..... 125,000	Long Eaton..... 500,000	Spa..... 100,000
Boston, U.S.A. 2,000,000	Huy..... 70,000	Lilie..... 900,000	Sevenoaks..... 300,000
Brisbane..... 1,500,000	Harrow..... 250,000	"..... 450,000	St. Petersburg..... 2,000,000
"..... 300,000	Harrogate..... 250,000	"..... 750,000	"..... 1,500,000
Burton-on-Trent..... 1,500,000	Halstead..... 150,000	"..... 250,000	St. Louis, U.S.A. 2,000,000
Barcelona..... 350,000	Heilbronn..... 200,000	"..... 350,000	"..... 2,000,000
Barking..... 100,000	Havana, Cuba. 750,000	Luckenwalde..... 250,000	"..... 1,000,000
Baelien & Co..... 20,000	Hastings..... 1,500,000	Liegwitz..... 300,000	Laclede 1,000,000
"..... 20,000	Huddersfield..... 300,000	Lincoln, U. S. A. 250,000	Silesian Coal Co..... 600,000
Bombay..... 400,000	"..... 750,000	Lawrence..... 500,000	San Francisco, U.S.A. 2,000,000
Buffalo, U.S.A., Mutual 750,000	"..... 1,500,000	Lynn..... 300,000	"..... 2,000,000
"..... Citizen 500,000	Hof..... 200,000	Lyons..... 1,500,000	Sheepbridge Coal Co..... 40,000
Brookline, U.S.A. 500,000	Hampton Wick..... 500,000	Maidstone..... 1,000,000	Stettin..... 200,000
Bergen..... 350,000	Heckmondwicke..... 500,000	Marseilles..... 1,500,000	Singapore..... 300,000
Berlin..... 1,250,000	Haverfordwest..... 100,000	Mons..... 500,000	Sutton..... 500,000
Bournemouth..... 1,000,000	Halifax, N.S. 350,000	Malines..... 250,000	Tonbridge..... 150,000
Bridgeport, U.S.A. 500,000	Hamm..... 200,000	Melbourne..... 1,500,000	Tipton..... 400,000
Brunswick..... 300,000	Halle..... 400,000	"..... 1,500,000	Tottenham..... 1,000,000
Beck & Co., St. Louis 100,000	Heidelberg..... 300,000	"..... 1,500,000	Toledo, U.S.A. 750,000
Barmen Rittershausen..... 600,000	Hartford, U.S.A. 1,000,000	"..... 1,500,000	Toronto 1,000,000
Bexhill..... 125,000	Ilkeston..... 300,000	Manchester..... 2,500,000	Uxbridge..... 300,000
Brooklyn, U.S.A. 1,000,000	Inverness..... 250,000	Middleton..... 400,000	Valparaiso 500,000
"..... Nassau 1,000,000	Ilkley..... 200,000	Manley, N. S. W..... 100,000	West Bromwich..... 1,000,000
Brunner, Mond & Co..... 400,000	Ilford..... 100,000	Minneapolis, U. S. A. 750,000	Willenhall..... 250,000
Cheltenham..... 2,000,000	Kingston-on-Hull..... 400,000	Magdeburg..... 300,000	Weston-super-Mare..... 500,000
Cannes..... 200,000	Kidderminster..... 750,000	Memphis, U. S. A. 750,000	Waltham..... 150,000
Croydon..... 1,500,000	Kidsgrove..... 100,000	Nottingham..... 1,250,000	Wormwood Scrubs..... 300,000
Copenhagen..... 200,000	Konigberg..... 1,000,000	"..... 2,500,000	Williamsburg, U.S.A. 600,000
Clevedon..... 200,000	King's Lynn..... 300,000	"..... 2,500,000	"..... 600,000
Columbus, U.S.A. 500,000	LONDON:—	"..... 2,000,000	Wellington..... 150,000
Cincinnati, "..... 1,500,000	The Gaslight and Coke Co.:	"..... 1,500,000	Warwick..... 300,000
"..... 1,500,000	Beckton..... 1,250,000	"..... 2,000,000	Wheeling, U.S.A. 500,000
Chicago 3,000,000	"..... 1,250,000	"..... 1,500,000	Walker..... 300,000
"..... 1,000,000	"..... 1,250,000	Newport, U.S.A. 430,000	Westgate..... 100,000
"..... 1,000,000	"..... 1,250,000	Newmarket..... 150,000	Wilmington, U.S.A. 500,000
Chemnitz..... 1,000,000	"..... 1,250,000	Newark, U.S.A. 680,000	Windsor, N. S. W..... 100,000
Crewe..... 1,250,000	"..... 1,250,000	Northfleet..... 200,000	Wolverton..... 100,000
Colonial Gas Works Co..... 100,000	"..... 2,500,000	New York, U.S.A. 2,000,000	Wellington, N. Z..... 250,000
Cadiz..... 300,000	Silvertown..... 1,000,000	Nice..... 600,000	Whitchurch..... 175,000
Cadiz..... 300,000	Bromley..... 2,000,000	Newcastle, N. S. W..... 200,000	Washington, U.S.A. 2,000,000
Charlottenburg..... 600,000	"..... 1,500,000	Numea, "..... 100,000	Wallasey..... 750,000
Dudley..... 750,000	"..... 1,500,000	Namur..... 250,000	Weimar..... 150,000
Driffield..... 100,000	"..... 1,500,000	Newark..... 350,000	Wurzen..... 200,000
Dukenfield..... 500,000	"..... 2,000,000	Oldbury..... 500,000	Worcester, U.S.A. 750,000
Dover..... 750,000	"..... 1,500,000	Otley..... 200,000	Yeadon..... 500,000
"..... 1,000,000	"..... 1,500,000	Oswestry..... 250,000	Yeovil..... 250,000
Deal..... 200,000	"..... 1,500,000		
Derby..... 1,500,000			

SOLE AGENT FOR WESTERN HEMISPHERE,

GEO. SHEPARD PAGE, 69 WALL STREET, NEW YORK

THE UNITED GAS IMPROVEMENT CO.

DREXEL BUILDING, PHILADELPHIA.

OFFICERS:

WILLIAM W. GIBBS, President.

GEORGE PHILLER, Vice-President.

SAML T. BODINE, Gen'l Manager.

RANDAL MORGAN, Gen'l Counsel.

EDWARD C. LEE, Sec'y and Treas.

ALEX. C. HUMPHREYS, Gen'l Supt.

WALTON CLARK, Ass't Gen'l Supt.

H. H. EDGERTON, Chem. and Eng'r.

DIRECTORS:

GEORGE PHILLER,

THOMAS DOLAN

HENRY C. GIBSON,

WM. T. CARTER,

WILLIAM G. WARDEN,

SAML T. BODINE.

BUILDERS, LESSEES AND PURCHASERS OF

✻ GAS WORKS. ✻

Orders solicited from Large Cities, Small Towns, Mills, Institutions, from all who want more Light for Less Money.

NATIONAL GAS LIGHT AND FUEL COMPANY,

No. 218 La Salle Street, Chicago.

THE SPRINGER SYSTEM

OF

Fuel and Illuminating Water Gas Works.

REFERENCES.

People's Gas Lt. & Coke Co.. Chicago, Ill.
Illinois Light, Heat & Power

Co. Chicago, Ill

Elgin National Watch Co. Elgin, Ill.

C. R. I. & P. R. R. Shops. Chicago, Ill.

Decatur Gas Lt & Coke Co. Decatur, Ill.

Niles Gas Light Co. Niles, Mich.

Newton Illuminating Co. Newton, Kansas.

Wellington Light & Heat Co. Wellington, Kansas.

Chippewa Falls Gas Lt. Co. Chippewa Falls, Wis.

Elkhart Gas Lt & Coke Co. Elkhart, Ind.

Madison City Gas Light Co. Madison, Wis.

South Bend Gas Light Co. South Bend, Ind.

Sheboygan National Gas Co. Sheboygan, Wis.

Salina Gas Light Co. Salina, Kansas.

The Rathbun Co. Deseronto, Prov. Ont.

Jefferson City Gas Lt. Co. Jefferson City, Mo.

Mankato Gas Light Co. Mankato, Minn.

Lima Gas Light Co. Lima, Ohio.

Minneapolis Gas Light and

Coke Co. Minneapolis, Minn.

Bellevue Water and Fuel } Bellevue, Campbell
Gas Light Co. } County, Ky.

Bucyrus Gas Lt. & Fuel Co. Bucyrus, Ohio.

Morris Gas Co. Morris, Ill.

Los Angeles Gas Co. Los Angeles, Cal.

San Diego Gas Fuel & Elec-

tric Lt. Co. San Diego, Cal.

Sioux Falls Gas Co. Sioux Falls, Dak.

Dakota Gas and Fuel Co. Grand Forks, Dak.

St. Johns Mutual Gas Co. St. Johns, Mich.

Stillwater Gas Light Co. Stillwater, Minn.

St. Paul Gas Light Co. St. Paul, Minn.

Emporia Electric and Gas

Light Co. Emporia, Kas.

Van Wert Gas Light Co. Van Wert, Ohio.

Lansing Gas Light Co. Lansing, Mich.

San Francisco Gas Lt. Co. San Francisco, Cal.

Shelbyville Gas Light Co. Shelbyville, Ind.

Great Falls Gas Light Co. Great Falls, N. H.

Belleville Gas Co. Belleville, Ontario

Rochester Lt. and Fuel Co. Rochester, Minn.

Northwestern Gas Light and

Coke Co. Evanston, Ill.

Lincoln Gas Light Co. Lincoln, Neb.

Davenport Gas Light Co. Davenport, Iowa.

Municipal Gas Co. Albany, N. Y.

Alliance Gas Light Co. Alliance, Ohio.

New Gas Light Co. Janesville, Wis.

Chicago Gas Lt. & Coke Co. Chicago, Ill.

Joliet Gas Co. Joliet, Ills.

Superior Light & Fuel Co. Superior, Wis.

Kewanee Gas Light Co. Kewanee, Ill.

Aberdeen Light & Fuel Co. Aberdeen, So. Dak.

Pierre Light and Fuel Co. Pierre, So. Dak.

*Standard Gas Light Co. New York City.

*Carlinville Gas Light Co. Carlinville, Ill.

* Building.

GUARANTEED ESTIMATES of Cost of Gas Furnished on Application.

GASHOLDER TANK CONSTRUCTION, ETC.

Gas Companies and others about to erect Gasholders will find it profitable to consult W. C. Whyte, who for over 30 years has made a specialty of

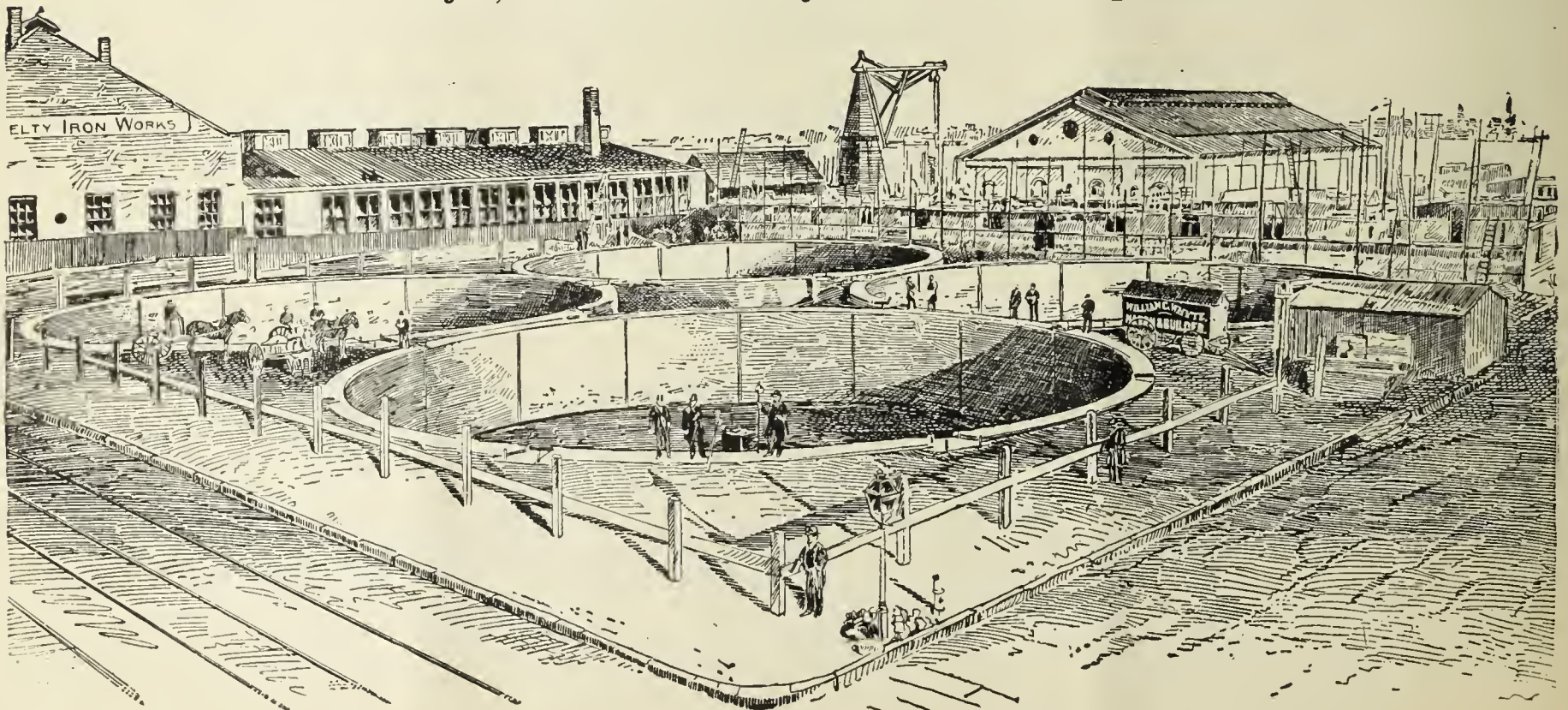

Tank Excavation and Mason Work.

Fifty Tanks now in operation show the sort of work done. Address

W. C. WHYTE, - No. 15 Cortlandt Street, N. Y. City.

CONNELLY & CO.,

SOLE MANUFACTURERS OF THEIR PATENTED SPECIALTIES.

"IRON SPONGE." Saves money, saves labor, and is the most efficient purifying agent ever offered as a substitute for lime. Now used in every State in the Union, and purifying daily over thirty-five million cubic feet. Should be used in every gas works. Its own saving will pay for it many times over.

AUTOMATIC GOVERNOR. Has been on the market but three years, and in that time has been introduced more generally than any invention ever designed for use in gas works. Over two hundred of them now in use. Sensitive; reliable; perfectly automatic; reduces leakage; satisfies consumers, and gives great relief to the Manager. No gas works is complete without one of these machines.

STEAM JET EXHAUSTER. Designed particularly for small works. Combines Exhaust Tube, Steam Governor Gas Compensator, and Bye-Pass Valves in the most compact form possible; occupies but little space; uses very little steam; operated by ordinary workmen; saves formation of carbon in retorts; increases yield 10 to 15 per cent. Specially adapted for mixing air with oil gas. No works too small to use them profitably.

Prices given on all our specialties delivered at any point in the United States. Correspondence solicited.

CONNELLY & CO., No. 111 Broadway, New York City.

WILBRAHAM GAS EXHAUSTER

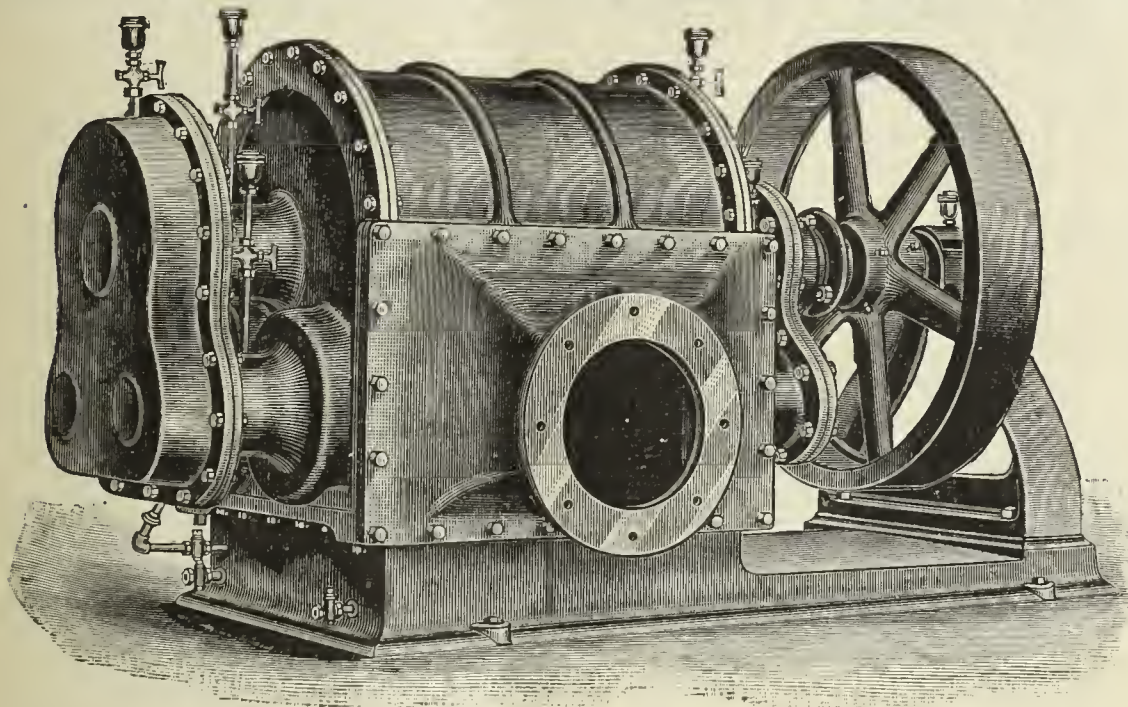

WILBRAHAM BROS.,
PHILADELPHIA, PA.

JARVIS ENGINEERING CO.,

61 Oliver St., Boston, Mass.

CONTRACTORS FOR ERECTING
COMPLETE STEAM OUTFITS FOR ELECTRIC LIGHTING STATIONS.

Steel Boilers set with Jarvis Pat. Boiler Setting
To burn **COKE SCREENINGS** for Fuel.

ARMINGTON & SIMS CO. ENGINES,
Belting direct to Dynamos, without using Shafting.

SEND FOR CIRCULARS.

REFERENCES.—Charlestown Gas & Electric Light Co., Charlestown, Mass.; Schenectady Gas & Electric Light Co., Schenectady N. Y.; Brookline Gas Co., Brookline, Mass.

Practical Electric Lighting

By A. BROMLEY HOLMES, A.M.I.C.E.

With 87 Illustrations. Third Edition. Price, \$1.00.

Electric Light Primer.

By CHARLES L. LEVEY.

A simple and comprehensive Digest of all the most important facts connected with the running of the Dynamo and Electric Lights, with Precautions for Safety, etc.

Price, 50 cents.

A. M. CALLENDER & CO., 42 Pine St., N.Y.

COMPOUND Condensing or Non-Condensing.
16 SIZES, 5 to 500 H. P.

Not yet equaled by any form of Engine for
HIGH FUEL DUTY AND SIMPLICITY.

STANDARD 13 Sizes in Stock.
5 to 250 H. P.
3000 in use in all parts of the Civilized World.

JUNIOR 6 Sizes in Stock,
5 to 50 H. P.
An Automatic Engine cheaper than a Slide Valve.
WELL BUILT. ECONOMICAL. RELIABLE.
Over 300 Sold the First Year.

All the above built strictly to Gauge with
INTERCHANGEABLE PARTS.
REPAIRS CARRIED IN STOCK.
SEND FOR ILLUSTRATED CATALOGUES.

WESTINGHOUSE
ENGINES
The Westinghouse Machine Co.
PITTSBURGH, PA. U.S.A.

SELLING DEPARTMENT IN THE UNITED STATES.

New York,	47 Cortlandt St.	} Westinghouse, Church, Kerr & Co.
Boston,	Hathaway Building,	
Pittsburgh,	Westinghouse Build'g,	
Chicago,	156, 158 Lake St.	
Philadelphia,	608 Chestnut St. M. R. Muckle, Jr. & Co.	
St. Louis,	302, 304 Washington Av.	} Fairbanks & Co.
Kansas City,	312 Union Avenue,	
Denver,	1330 Seventeenth St.	
Omaha,	1619 Capitol Avenue, F. C. Ayer.	
Pine Bluffs, Ark.		Geo. M. Dilley & Sons.
Salt Lake City,	250 S. Main St.	} Utah & Montana Machinery Co.
Butte, Mont.	L. Granite St.	
San Francisco,	21, 23 Fremont Street,	Parke & Lacy Co.
Portland, Or.	33, 35 N. Front St.	Parke & Lacy Mch. Co.
Charlotte, N. C.	36 College St.	} The D. A. Tompkins Co.
Atlanta, Ga.	45 S. Prior St.	
Dallas, Tex.		Keating Imp. & Machine Co.
Chattanooga, Tenn.,		G. E. James & Co.

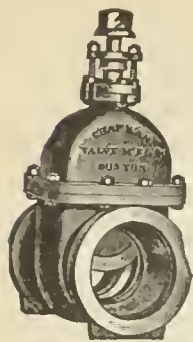

CHAPMAN VALVE MANUFACTURING CO.,

MANUFACTURERS OF

Valves and Gates for Gas, Ammonia, Water, Etc.

Also, Cate Fire Hydrants With and Without Independent Nozzle Valve. All Work Guaranteed.

WORKS & GEN'L OFFICE:
Indian Orchard, Mass.

TREASURER'S OFFICE:
72 Kilby & 112 Milk Sts, Boston, Mass.

LUDLOW VALVE MFG. CO.

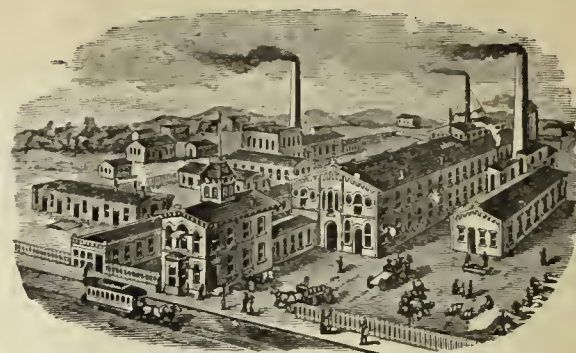

OFFICE AND WORKS,

938 to 954 River Street and 67 to 83 Vail Av.,
TROY, N. Y.

Parson's Steam Blower,

FOR IMPROVING BAD DRAUGHT IN BOILERS, AND FOR BURNING BREEZE OR OTHER WASTE MATERIAL.

PARSON'S TAR BURNER,

FOR UTILIZING COAL TAR AS FUEL.

PARSON'S AIR JET TUBE CLEANER,

FOR CLEANING BOILER TUBES.

These devices are all first-class. They will be sent to any responsible party for trial. No sale unless satisfactory. Manufactured by the WATERTOWN STEAM BLOWER COMPANY.

H. E. PARSON, Supt., 33 & 35 Liberty St., N.Y

MILLS' REVERSIBLE LIME TRAY,

AND

WOODWORK

Of Every Description

NEEDED BY GAS WORKS.

SEND FOR CIRCULAR AND PRICE LIST TO

BARTLETT, HAYWARD & CO.,

Pratt and Scott Streets, Baltimore, Md.

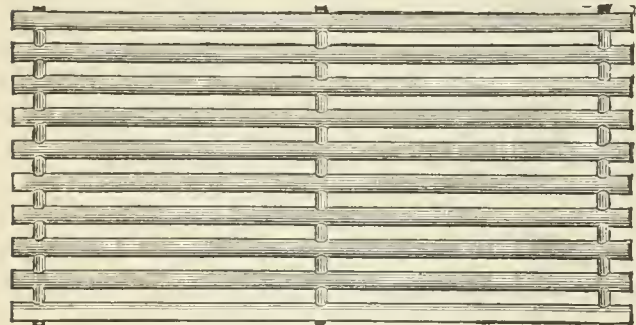

Hydraulic Main Dip Regulators, also
Check Valves, Foot Valves, Yard-
wash and Fire Hydrants.
Send for Circulars.

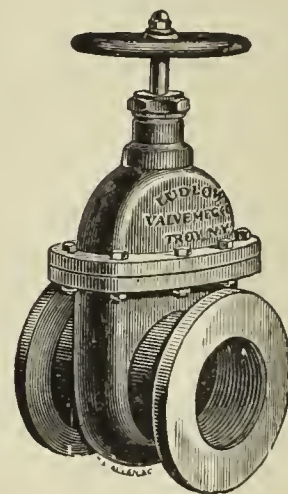

Valves.—Double and Single Gate, 1/2 in. to
48 in., outside and inside Screws. Indica-
tor, etc., for Gas, Water, Steam, and Oil.
Send for Circulars.

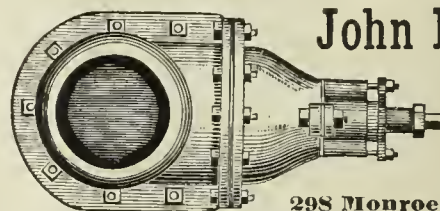

John McLean

Manufacturer

GAS
VALVES.

298 Monroe Street, N. Y.

SPECIAL TRAYS FOR IRON SPONGE OR OXIDE OF IRON.

CHURCH'S TRAYS A SPECIALTY.

REVERSIBLE-STRONGEST-MOST DURABLE-MOST EASILY REPAIRED.

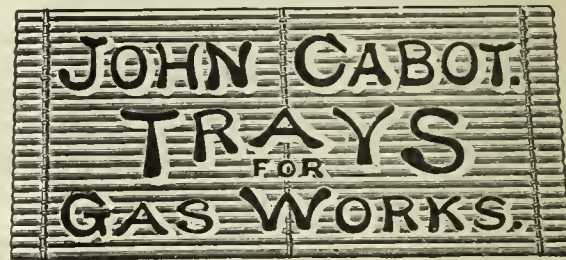

306-310 ELEVENTH AVENUE, NEW YORK.

WE ALSO MAKE THE CHEAPEST AND STRONGEST
REVERSIBLE BOLTED TRAYS IN THE MARKET.

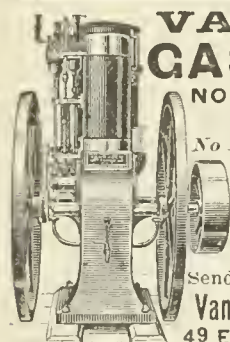

VAN DUZEN GAS ENGINE

NO BOILER. NO COAL.
NO ENGINEER.

No Extra WATER RENT
or INSURANCE.

INSTANTLY STARTED.

DURABLE, RELIABLE.

SAFE and ECONOMICAL.

Send for description and prices.

Van Duzen Gas Engine CO.,

49 E. 2nd St., CINCINNATI, O.

A. MacKinnon Machine Co., Agts., 22 Warren St., N.Y.

The Management of Small Gas Works.

BY C. J. R. HUMPHREYS.

Price, \$1.

Orders to be sent to A. M. CALLENDER & CO..

42 PINE STREET, NEW YORK.

THE CLERK GAS ENGINE CO.,

Main Office, 1012, 1014, 1016, 1018 Filbert St., Philadelphia, Pa.

WM. W. GOODWIN, Prest.

E. STEIN, Sec.

S. LEWIS JONES, Asst. Sec.

A. J. DOTY, Supt.

The utility and convenience of the Gas Engine being no longer an open question, it only remains now for intending purchasers to select the BEST. We claim for the CLERK GAS ENGINE that it is equal to any other manufactured as regards steadiness in running, simplicity, and ease of keeping in repair, and that it gives the greatest amount of power for the least money (both in first cost and expense of running) of any engine made. In support of this claim we refer to the test of the Gas Engines made under the direction of the American Institute of New York, in December, 1885, and heretofore published in these columns. These engines are especially adapted for continuous running under heavy loads, and we can refer to Engines which have run 22 hours a day for months at a time

Made in Sizes of 5 10 15² 20, and 25 Horse Power. All Engines Guaranteed for One Year.

GAS STOVES.

GAS METERS.

GAS STOVES.

THE AMERICAN METER CO.,

MANUFACTURERS OF

GAS METERS, Station Meters,

METER PROVERS, PHOTOMETERS,

PRESSURE GAUGES OF ALL KINDS,



Standard 3 Diaphragm Dry Meter

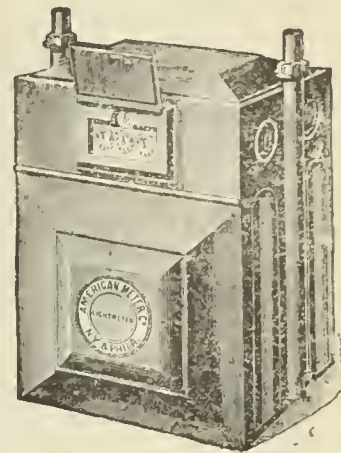

Standard 2 Diaphragm Dry Meter.

AND

Apparatus for Testing the Quantity and Quality of Gases.

GAS STOVES FOR HEATING AND COOKING

Sole Agents in the United States for

Verity's Patent Gas Fires.

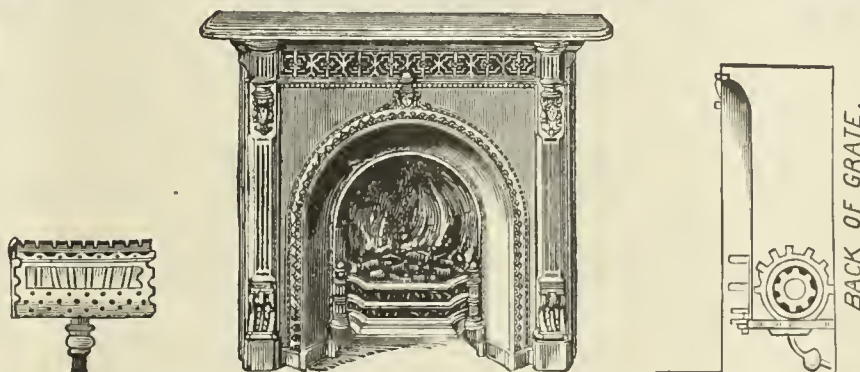

Circulars and Price Lists on Application.

MANUFACTORIES,

508 to 514 West Twenty-second St., N. Y.

Arch and Twenty-second St., Phila.

Nos. 244 & 246 North Wells Street, Chicago, Ill.

AGENCIES,

No. 177 Elm Street, Cincinnati, Ohio.

No. 222 Sutter Street, San Francisco, Cal

No. 810 North Second Street, St. Louis, Mo.

GAS STOVE SHOW ROOMS, No 242 Sixth Avenue, New York City.

RETORTS AND FIRE BRICK.

RETORTS AND FIRE BRICK.

RETORTS AND FIRE BRICK.

J. H. GAUTIER & CO., CORNER OF GREENE AND ESSEX STREETS, JERSEY CITY, N. J.

MANUFACTURERS OF Clay Gas Retorts, Gas House Tiles, Fire Bricks, Etc. Etc.

Ground Clay, Fire Brick and Fire Sand in Barrels,

J. H. GAUTIER. C. E. GREGORY. C. E. GAUTIER.

BROOKLYN Clay Retort & Fire Brick Works, (EDWARD D. WHITE & CO.) Manufacturers of Clay Retorts, Fire Brick, Gas House and other Tile. VAN DYKE, ELIZABETH, RICHARDS & PARTITION STS. Office, 88 Van Dyke St., Brooklyn, N. Y.

LACLEDE FIRE BRICK MFG. CO., MANUFACTURERS OF Fire Brick, Gas Retorts,

AND ST. LOUIS STANDARD SEWER PIPE. Blast Furnace and Cupola Linings, every description of Fire Clay Material, Fire Clay Flue Linings, Chimney Tops Dry Milled and Crude Fire Clays, etc.

OFFICE AND DEPOT 901, 903, and 905 Pine Street, ST. LOUIS, MO.

ESTABLISHED IN 1845.

B. KREISCHER & SONS, OFFICE FOOT OF HOUSTON ST., E.R., N.Y.

Gas Retorts, TILES, FIRE BRICK. AND EVERYTHING IN THE FIRE CLAY LINE.

MANHATTAN FIRE BRICK & ENAMELLED CLAY RETORT WORKS ADAM WEBER.

CLAY GAS RETORTS AND RETORT SETTINGS FIRE BRICKS, TILES, ETC.,

Office and Works, 15th Street and Avenue C., N. Y.



Works, LOCKPORT STATION, PA.

—ESTABLISHED 1864.— JAMES GARDNER, JR.,

Office, Rooms 19 & 20, Lewis Block, PITTSBURGH, PA, P. O. Box 373.

Successor to WILLIAM GARDNER & SON.

Fire Clay Goods for Gas Works.

CHAS. H. SPRAGUE & SON, No. 70 KILBY STREET, BOSTON, MASS., Agents for the New England States.

GEO. C. HICKS, Prest. CHICAGO CHAS. A. REED, Sec. & Treas. Retort and Fire Brick Co., MANUFACTURERS OF Fire Clay Goods of all Kinds, AND BEST QUALITY ONLY. Regenerative Furnaces & Water Gas Goods. 45th St., Clark to La Salle, Chicago.

GEROULD'S IMPROVED RETORT CEMENT. A Cement for patching retorts, putting on mouthpieces, and making up all bench-work joints. This Cement is mixed ready or use. Economical and thorough in its work. Fully warranted o stick. For recommendations and price list address C. L. GEROULD & CO., 5 & 7 Skillman St., Brooklyn, N. Y. Western Agent, H. T. GEROULD, Mendota, Ill.

Parker-Russell Mining and Mfg. Co., CITY OFFICE: { Mermod-Jaccard Bldg., Rooms 307 & 308, Broadway and Locust Street, St. Louis, Mo. PROPRIETORS OF THE OAKHILL GAS RETORT & FIRE BRICK W'KS

Our immense establishment is now employed almost entirely in the manufacture of materials for GAS COMPANIES. We have studied and perfected three important points. Our retorts are made to stand changes of temperature, the strongest heats of the furnace, and the abrasion of feeding and emptying. We furnish and build Half-Depth or Full REGENERATOR FURNACES of different kinds and most approved styles. Correspondence solicited.

THOS. SMITH, Prest. AUGUST LAMBLA, Vice-Prest. & Supt. BALTIMORE RETORT & FIRE BRICK CO. MANUFACTORY AT LOCUST POINT, BALTIMORE, MD.

Clay Retorts, Blocks & Tiles, FIRE BRICK, FIRE CLAY, AND FIRE CEMENT. Red and Buff Ornamental Tiles and Chimney Tops. Drain and Sewer Pipe (from 2 to 30 inches). Baker Oven Tiles 12x12x2 and 10x10x2. WALDO BROS., 88 WATER ST., BOSTON, MASS Sole Agents the New England States.

1889 DIRECTORY 1889

OF THE GAS LIGHT COMPANIES of the UNITED STATES & CANADA.

Price, \$3.00.

A. M. CALLENDER & CO., No. 42 Pine Street, N. Y. City.

HENRY MAURER & SON,

(ESTABLISHED 1856.)

**EXCELSIOR FIRE BRICK & CLAY
RETORT WORKS**

WORKS, Perth Amboy, N. J.
OFFICE, 418 to 422 East 23d St., N. Y.

**Clay Gas Retorts,
BENCH SETTINGS,
Fire Brick, Tiles, Etc.**

**FLEMMING'S
Generator-Gas Furnace**

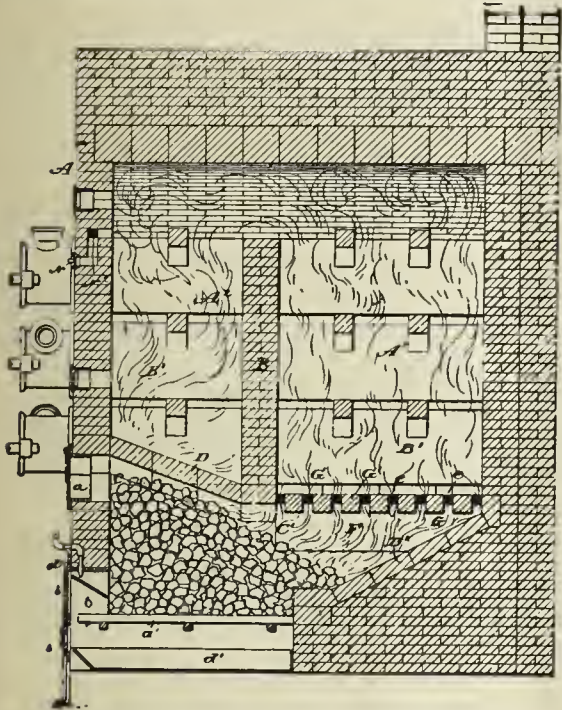

Materials furnished and Benches erected by

J. H. GAUTIER & CO., - Jersey City, N. J.

Address as above, or D. D. FLEMMING, Jersey City, N. J.

FRED. BREDEL,

CONTRACTOR FOR THE COMPLETE

Erection and Equipment of Gas Works.

SOLE PROPRIETOR OF THE

KLOENNE PATENTS

FOR NORTH AMERICA.

REGENERATIVE FURNACES.

(900 Retorts are now fired in America by the Kloenne-Bredel System.)

SELF-SEALING MOUTHPIECES.

(Over 800 Now in Use.)

Standard Condensers. Washer-Scrubbers.

TAR WASHERS FOR WATER GAS PLANTS.

(In use in the works of the Chicago Gas Lt. Co.)

GASHOLDERS.

Bredel's Automatic Gas Governor.

Refers, by permission, to Mr. Eugene Vanderpool, Newark, N. J.; Mr E. G. Cowdery, Milwaukee, Wis.; and Mr. Theo. Forstall, Chicago, Ills. For further information, address

FRED. BREDEL,

No. 208 East Seventeenth Street, N. Y. City.

HENRY PRATT & CO.,

BUILDERS OF THE

PRATT & RYAN WATER GAS GENERATORS,

Arranged to Use Either Crude Oil or Naphtha.

Condensers, Scrubbers, Purifiers, and all Apparatus for Coal or Water Gas.

IRON ROOFS, BOILERS, TANKS, ETC.

Orders and Correspondence Solicited.

Plans and Estimates Furnished for New Works or for the Alteration of Old Works.

Office and Works, 869 to 875 So. Halsted St. CHICAGO, ILL.

THE BRENNER SELF-SEALING RETORT DOOR.

Simple, Strong, and Durable.

CLOSES ABSOLUTELY TIGHT & IS LOCKED BY A CAM LEVER. ALL NECESSARY ADJUSTMENT FOR WEAR PROVIDED.

BUILT BY

SMITH & SAYRE MFG. CO.,

No. 245 Broadway, - - - New York City.

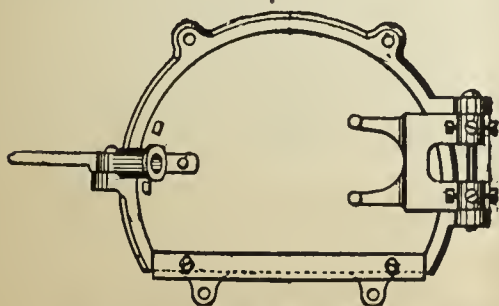

Brenner Self-Sealing Retort Door.

WILLIAM B. LUNDIE, Superintendent of the 42d Street Station of the Consolidated Gas Company, of New York, writes, under date of Jan. 4, 1889:

"We have 320 Brenner Self-Sealing Lids in use at this Station, built by the Smith & Sayre Mfg. Co. They require very little attention, and are the best of the kind that I have seen, giving entire satisfaction."

GAS AND WATER PIPES.

GAS AND WATER PIPES.

ENGINEERS.

SAM'L R. SHIPLEY, Pres.
HENRY B. CHEW, Tre

JAS. P. MICHELLON, Sec.
WM. SEXTON, Supt.

GLOUCESTER IRON WORKS,
GLOUCESTER CITY, N. J.



Cast Iron Gas & Water Pipes, Stop Valves, Fire Hydrants, Gasholders. &c.

Office, Rooms 61 and 63 Bullitt Building, 131 S. 4th St., Phila., Pa.

WARREN FOUNDRY AND MACHINE CO.,

Established 1856. Works at Phillipsburgh, N. J.

New York Office, 160 Broadway.

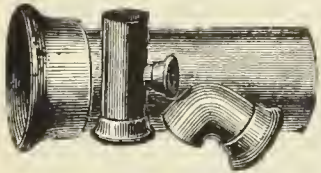

CAST IRON WATER AND GAS PIPE,

FROM TWO TO FORTY-EIGHT INCHES DIAMETER. ALSO, ALL SIZES OF

Flange Pipe for Sugar House and Mine Work. Branches, Bends, Retorts, etc., etc.

DENNIS LONG & COMPANY,

LOUISVILLE, KY.,



Manufacture Exclusively

CAST IRON GAS & WATER PIPE & SPECIAL CASTINGS
OF ALL SIZES.

King's Treatise on Coal Gas.

A standard text-book for the Engineers and Managers of Gas Works, and for all who are concerned or take an interest in the manufacture and distribution of Coal Gas, and in the utilization of the Secondary Products resulting therefrom; treating also of the Gas Engine, and of Gas Cooking and Heating Appliances.

In 3 Vols. Price per Vol., \$10. Sold either by Volume or in Sets.

A M. CALLENDER & CO., 42 Pine St., N. Y.

P. D. WANNER, Chairman. A. H. MELLERT, Mangr. of Wk
R. B. KINSEY, Secretary. F. A. KNOPP, Treasurer.

MELLERT FOUNDRY & MACHINE CO. Ltd.
and **READING FOUNDRY CO., Ltd.,**
Reading, Pa.

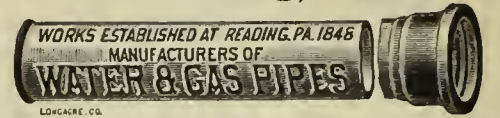

Specials—Flange Pipe, Valves and Hydrants
Lamp Posts, Retorts, etc.

General Foundry and Machine Work.
JOHN FOX, Selling Agent. 160 Broadway, N. Y.

THE OHIO PIPE COMPANY,

MANUFACTURERS OF

Cast Iron Gas & Water Pipe,

BRANCH AND SPECIAL CASTINGS.

Gas-House Bench Castings, Hydraulics, Lamp Posts, Flange Pipe
and Specials, Architectural Castings, Building Columns,
Joists, Cellar Grates, Sash Weights, etc.

GENERAL FOUNDERS AND MACHINISTS.
Columbus, Ohio.

M. J. DRUMMOND,



SPECIAL CASTINGS AND LAMP POSTS.
Office, Corbin Building, 192 Broadway, N. Y.

EMAUS PIPE FOUNDRY.

DONALDSON IRON COMPANY. EMAUS, PA.



MANUFACTURERS OF

CAST IRON PIPE AND SPECIAL CASTINGS
FOR WATER AND GAS.

JOS. R. THOMAS,

No. 42 Pine Street, N. Y. City.

CONSULTING AND CONSTRUCTING

Gas Engineer and Contractor.

PLANS, SPECIFICATIONS, AND ESTIMATES
FURNISHED.

Contracts taken for all Appliances
required at a Gas Works,
Either for New Works or Extensions to Old Plants.

WM. MOONEY

(Successor to WM. FARMER)

No. 94 Liberty St., N. Y. City.

GAS ENGINEER AND CONTRACTOR FOR THE ERECTION
OF GAS WORKS, OR APPARATUS OF ANY
CAPACITY.

Plans and Specifications Furnished.

WM. GARDNER,
Gas Engineer,

Lewis Block, Room 20, Pittsburgh, Pa.

Those who intend to make alterations in existing gas plants, or who contemplate the erection of new works, will find it to their interest to open correspondence with the above. Plans made and estimates furnished.

BARTLETT, HAYWARD & CO.

Baltimore, Md.

Triple Double, & Single-Lift

GASHOLDERS.

Iron Holder Tanks.

ROOF FRAMES.

Cirders.

BEAMS.

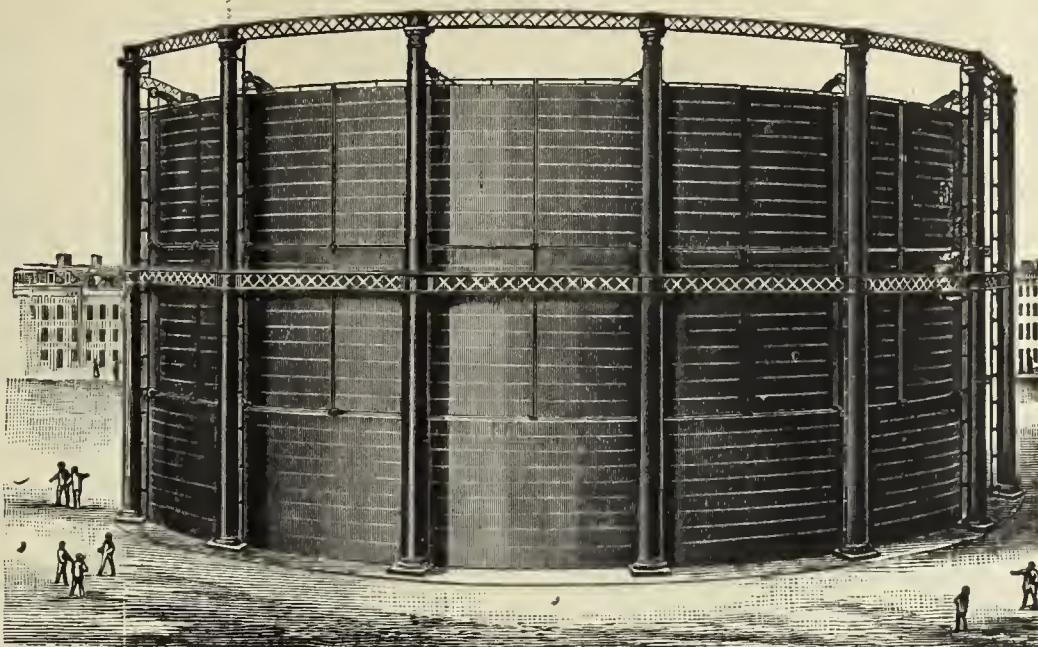

PURIFIERS.

CONDENSERS.

Scrubbers.

BENCH CASTINGS.

OIL STORAGE TANKS.

Boilers.

The Wilkinson Water Gas Process.

THIRTY-CANDLE, NON-CONDENSABLE, FIXED GAS. THE MOST SUCCESSFUL GAS PROCESS IN OPERATION.

Munich Regenerative Furnace, System Drs. Schilling & Bunte.

HAZELTON BOILERS.

Gas Works Designed and Constructed.

Pascal Iron Works. ESTABLISHED 1821. Delaware Iron Works.

MORRIS, TASKER & CO.,

INCORPORATED.

OFFICE, 224 SOUTH THIRD STREET, - - PHILADELPHIA, PA.

CONTRACTORS, BUILDERS, AND MANUFACTURERS OF

Gas, Water & Sugar Works

Bench Castings.

Condensers.

Scrubbers.

Purifiers.

Hyd. Carriages.

Iron Floors,

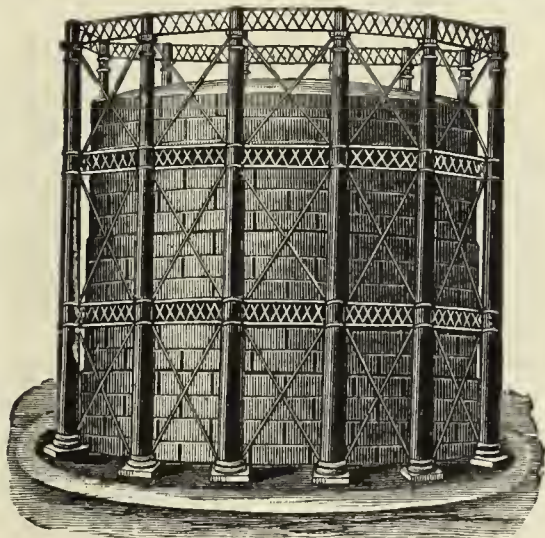

Iron Roofs.

Street Stops,

Valves, etc.

Stand-Pipes.

Water & Oil

Tanks, all Sizes.

Single, Double, and Triple-Lift Gas Holders.

SELF-SEALING RETORT LIDS. STAMPED STEEL RETORT LIDS.

Locomotive Water Columns, Filters, etc. Boiler Tubes, Wrought Iron Pipe & Fittings

Plans, Specifications and Estimates for all kinds of Machinery furnished on application.

Foundries & Works,
MILLVILLE, FLORENCE,
and CAMDEN, N. J.

R. D. WOOD & CO.,

Engineers,
Iron Founders,
and
Machinists.

400 Chestnut St., PHILADELPHIA, PA.

MANUFACTURERS OF

CAST IRON PIPE,

Gas Holders,

SINGLE, DOUBLE, AND TRIPLE LIFTS, WITH
OR WITHOUT WROUGHT IRON
OR STEEL TANKS.

PURIFIERS, CONDENSERS.

Scrubbers.

BENCH WORK.

Iron Floors and Roofs, Plate Girders.

Heavy Loam Castings.

HYDRAULIC WORK.

Lamp Posts, Valves, Etc.

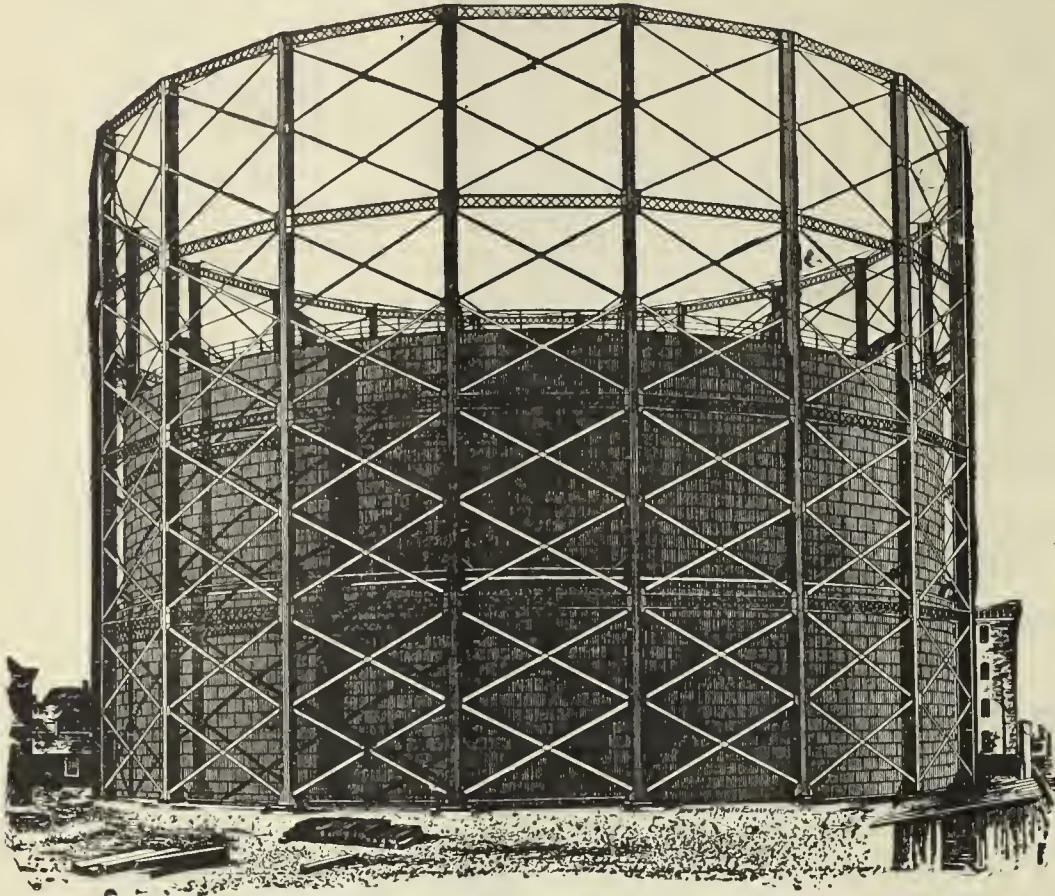

ROOTS' NEW GAS EXHAUSTER.

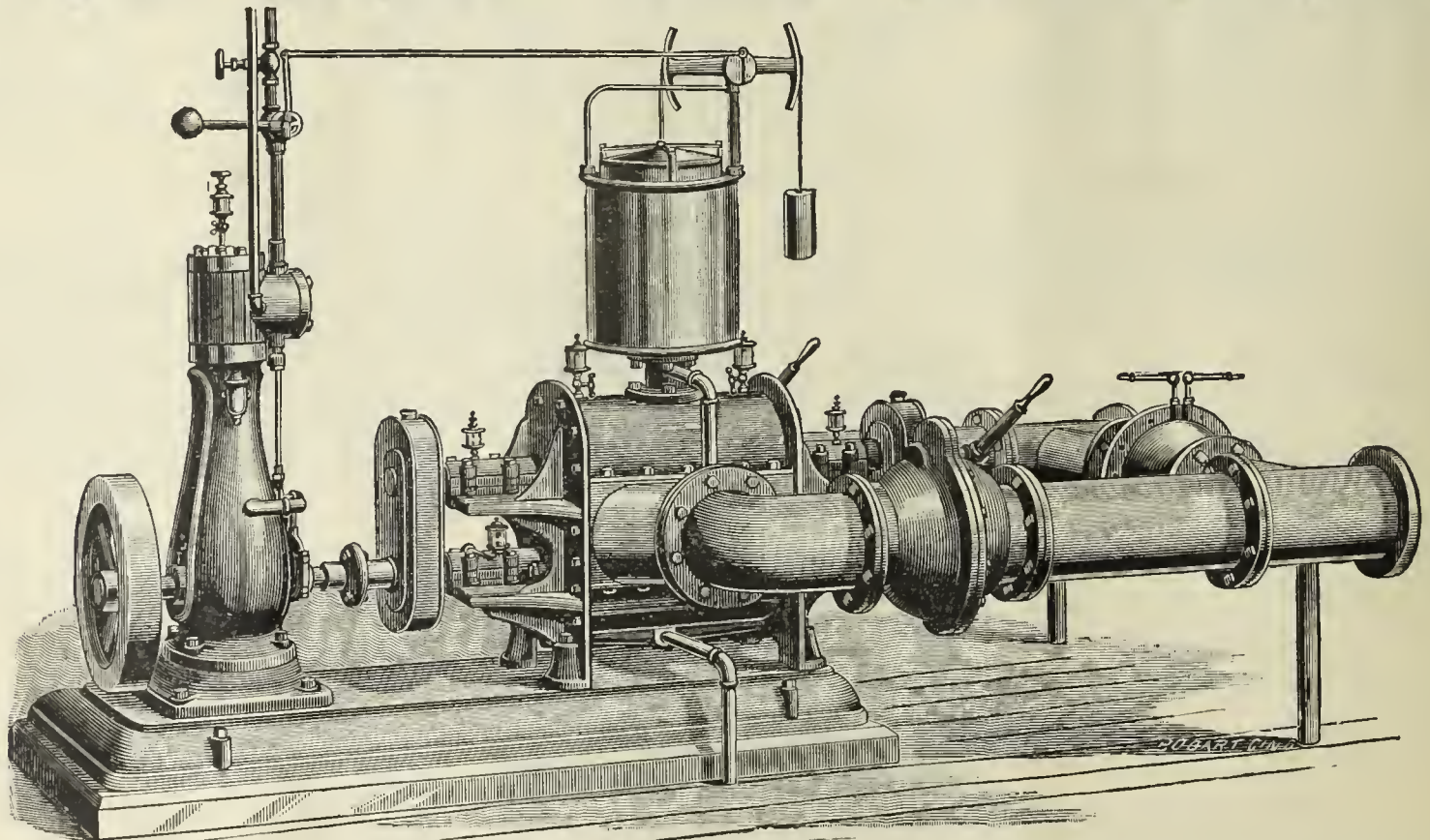

We will take pleasure in furnishing estimates on complete plants, including **GAS EXHAUSTER, ENGINE,** and **GAS GOVERNOR,** all connected, complete, on same bedplate. Also, estimates for **GAS VALVES, BY-PASS VALVES,** and **PIPE FITTINGS,** arranged in any manner to suit the exhauster room or main connections.

All flanges of pipe and valve fittings faced off, with bolt holes drilled, all ready to go together.

S. S. TOWNSEND, General Agent, } 22 Cortlandt St., N. Y. P. H. & F. M. ROOTS CO., Connerville, Ind.
COOKE & CO., Selling Agents,

GAS WORKS APPARATUS AND CONSTRUCTION.

GAS WORKS APPARATUS AND CONSTRUCTION.

JAMES R. FLOYD & SONS,

(SUCCESSORS TO HERRING & FLOYD)

Oregon Iron Works,

W. 20th & 21st. Sts., bet. 10th & 11th Avs.,

NEW YORK CITY.

Engineers and Contractors

FOR THE

CONSTRUCTION OF GAS WORKS.

MANUFACTURERS OF

All Kinds of Castings and General Ironwork

FOR

GAS APPARATUS.

Bench Castings, Regenerative and Half Regenerative Furnace Castings.

Condensers, Scrubbers, Purifiers, Street Drips and Connections,

Valves,

Hydraulic Hoisting Purifier Carriage, Self-Sealing Retort Lids, Improved Valve Stand and Indicator, Seller's Cement.

Plans, Specifications, and Estimates furnished for Construction of New or Alteration of Old Works.

CONTINENTAL IRON WORKS.

THOS. F. ROWLAND, Prest.

WARREN E. HILL and CHAS. H. CORBETT, V-Prests.

THOS. F. ROWLAND, JR., Sec. & Tr.



P. O. Station G., BROOKLYN, N. Y.

ENGINEERS AND MANUFACTURERS OF

Gas Holders

CONDENSERS, SCRUBBERS, VALVES,

PURIFIERS, SELF-SEALING RETORT LIDS

Hydraulic Mains,

And all other articles connected with the manufacture and distribution of Gas.

H. RANSHAW, Prest. & Mangr.

WM. STACEY, Vice-Prest.

T. H. BIRCH, Asst. Mangr.

R. J. TARVIN, Sec. & Treas.

STACEY MFG. CO.,

MANUFACTURERS OF

Single and Telescopic Gasholders,

IRON ROOFS, BRIDGES, LAMP POSTS,

Water and Oil Tanks, Coal Elevator Cars,

COKE CRUSHERS, BENCH CASTINGS,

And all kinds of Wrought and Cast Iron Work used in the erection of Coal and Oil Gas Works Rolling Mill Machinery and Heavy Castings a Specialty.

Foundry:

33, 35, 37 & 39 Mill Street.

Wrought Iron Works:

16, 18, 20, 22, 24 & 26 Ramsey Street:

Cincinnati, Ohio.

Bouton Foundry Co.,

FOUNDERS AND MACHINISTS,

CHICAGO, ILL.

Gas Works Apparatus,

PURIFIERS, CONDENSERS,

Bench Work

SPECIALS, LAMP POSTS,

SCRUBBERS,

Iron Roofs and Floors.

Plans and Estimates furnished for new works or extensions of old works.

1842. DEILY & FOWLER, 1889.

Laurel Iron Works.

Address, No. 39 Laurel Street, Philadelphia, Pa.

BUILDERS OF

GASHOLDERS,

Single and Telescopic.

Holder Built 1884 to 1888, Inclusive:

- | | | | | |
|----------------------------|-----------------------------|---------------------------|--------------------------|------------------------|
| Newport, R. I. | Long Island City, N. Y. | Port Chester, N. Y. | Malden, Mass. | West Chester, Pa. (2d) |
| Portland, Oregon. | Macon, Ga. | New Rochelle, N. Y. | Paducah, Ky. | Lancaster, Pa. (3d) |
| Allgheny, Pa. (2d.) | York, Pa. | Salem, N. J. (3d) | Norwich, Conn. | Tacony, Pa. (two) |
| Atlanta, Ga. (2d.) | Chester, Pa. | Omaha, Neb. (2d) | Seattle, W. T. | Mount Vernon, N. Y. |
| N.Y. City (Central Gas Co) | Hazleton, Pa. (2d.) | Lynn, Mass. (2d) | San Diego, Cal. | Binghamton, N. Y. |
| Lynchburg, Va. (2d.) | Stateo Island, N. Y. | Little Rock, Ark. | Northern Gas Lt. Co., of | Concord, N. H. |
| Saylesville, R. I. | Saugerties, N. Y. | Irrington, N. Y. | New York, N. Y. | Dover, Del. (2d) |
| Rondout, N. Y. | Clinton, Mass. (Lan. Mills) | South Boston, Mass. | Westerly, R. I. | Calais, Me. |
| Atlantic City, N. J. | Chattanooga, Tenn. | Rye, N. Y. (2) | Willimantic, Conn | New Loudon, Conn. (2d) |
| Augusta, Ga. | Galveston, Texas. (3d.) | Woodstock, Ont. | Montclair, N. J. | West Chester, N. Y. |
| Waltham, Mass. (2) | Omaha, Neb. | Malden, Mass. | Attleboro, Mass. | Bay Shore, L. I. |
| Mahanoy City, Pa. | Fort Plain, N. Y. | Staten Island, N. Y. (2d) | Santa Cruz, Cal. | Washington, D. C. |
| New Castle, Pa. | Brunswick, Ga. | Woodstock, Ont. | Erie, Pa. (2d) | |

SMITH & SAYRE MFG. COMPANY,

G. G. PORTER, Prest.

245 Broadway, N. Y.

CHAS. W. ISBELL, Sec'y.

Machinery & Apparatus for Gas Works

Drawings, Plans, and Estimates Furnished for the Improvement, Extension, or Alteration of Gas Works, or for the Construction of New Works.

Mackenzie's Patent Rotary and Steam Jet Gas Exhausters, Governors, Compensators, Condensers, Washers, Scrubbers. Isbell's Patent Automatic Street Pressure Governor, Gas and Water Valves, Hydraulic Main Dip Regulator, Bench Castings, etc. Purifying Boxes and "Standard" Scrubbers, Isbell's Patent Self-Sealing Retort Doors.

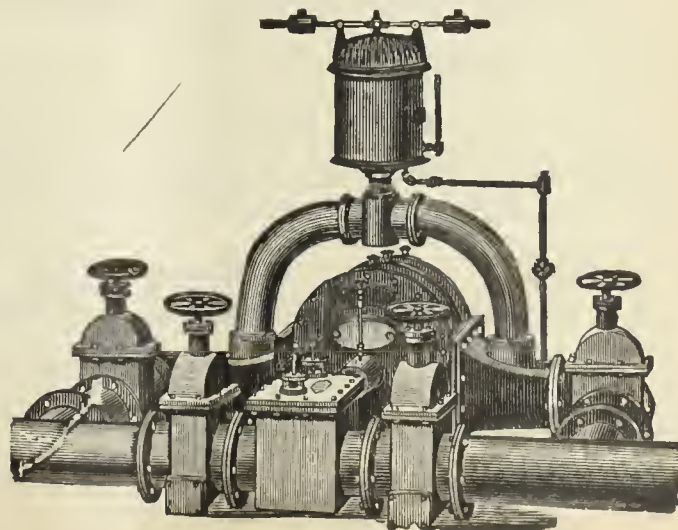

GAS COALS.

CANNEL COALS.

- GAS ENRICHERS.

JAMES D. PERKINS. **PERKINS & CO.,** F. SEAVERN.
228 & 229 Produce Exchange, New York.

Cable Address, "PERKINS, NEW YORK."

Post Office Box 3695, New York.

GENERAL SALES AGENTS FOR

The Youghiogeny River Coal Company's

OCEAN MINE YOUGHIOGHENY GAS COAL.

HON. W. L. SCOTT, Prest.

M. H. TAYLOR, Vice-Prest.

This Colliery is located at SCOTT HAVEN, PA., in the center of the Youghiogeny Gas Coal District, and produces the ONLY RELIABLE YOUGHIOGHENY COAL for gas purposes. (See Map on p. 87 of this JOURNAL, Feb. 16, '85.)

POINTS OF SHIPMENT,

Locust Point, BALTIMORE.

Pier No. 62, PHILADELPHIA.

Also, SOLE AGENTS for the

**BRECKENRIDGE CANNEL,
OF KENTUCKY.**

Within the past two years we have delivered this Cannel to over ONE HUNDRED COMPANIES IN THIRTY-THREE DIFFERENT STATES, and it is now in use in some of the large Gas Works

On the Continent and in South America,

where it successfully competes with the Australian Shale. It is the ONLY AMERICAN GAS CANNEL of sufficiently high grade to warrant EXPORTATION TO EUROPE AND SOUTH AMERICA, and it is the only economical substitute for OIL OR NAPHTHA. ONE GROSS TON will produce

10,000 Cubic Feet of 75 Candle Gas,	} equal to {	750,000 Candle Feet of Gas, and 26 Bushels of merchantable Coke weighing 900 Pounds
or 12,500 " " 60 " "		
or 15,000 " " 50 " "		

This is the ONLY GAS CANNEL that will produce a REALLY MERCHANTABLE COKE. It can be delivered in parcels of one carload or more to any point in the United States or Canada. Cargo shipments of any size required can be made from NEW YORK, PHILADELPHIA, BALTIMORE, or NEWPORT NEWS. Samples will be sent and particulars of price, etc., forwarded upon application to above address.

JAMES & WILLIAM WOOD,
Gas and Cannel Coal Contractors,

No. 40 St. Enoch Sq., Glasgow. No. 2 Talbot Court, London.

Proprietors of the BATHVILLE COLLIERIES (which produce the celebrated BOGHEAD CANNEL), Shields, Shieldmuir, Drumpeller, and other Collieries. This Firm offer

STANDARD CANNELS,

Unequaled as Gas Enrichers.

Also, WEST FAIRMONT GAS COAL, of W. Va.

Analyses, prices, and all further information furnished on application to

Agency for U.S., Room 93, Nos. 2 & 4 Stone St., N.Y. City.

The Standard Oil Company,

REFINERS OF

NAPHTHA AND GASOLINES.

ALSO MANUFACTURERS OF

A Special Grade of Naptha for Gas Companies

FOR ENRICHING COAL GAS.

Correspondence solicited.

No. 43 Euclid Avenue, Cleveland, Ohio.

To Gas Companies.

We make to order CAP BURNERS to burn any amount under a stated pressure. Send for samples.

Also, SERVICE CLEANERS, DRIP PUMPS, and STREET MAIN PROVING APPARATUS.

C. A. GEFROER,

248 N 8th Street, Phila., Pa.

COKE CRUSHERS.

GAS COALS.

GAS COALS.

Newburgh Orrel Coal and Coke Co.

MINERS AND SHIPPERS OF
STEAM, SMITHING, AND GAS COALS,
Foundry and Crushed Coke.

Home Office, 33 S. Gay Street, Baltimore, Md.
J. HARRY LEE, President.
CHAS. W. HAYS, Agent, No. 1 Broadway, N. Y.
Shipping Wharves, Locust Point, Baltimore.

The Despard Gas Coal Co.,

MINERS AND SHIPPERS OF
DESPARD GAS COAL,
AND MANUFACTURERS OF
COKE.

MINES, Clarksburg, Harrison Co., W. Va.
WHARVES, Locust Point, Baltimore, Md.
OFFICE, 225 E. German St., " "

ROUSSEL & HICKS, } *AGENTS.* } BANGS & HORTON,
71 Broadway, N. Y. } 60 Congress St., Boston.

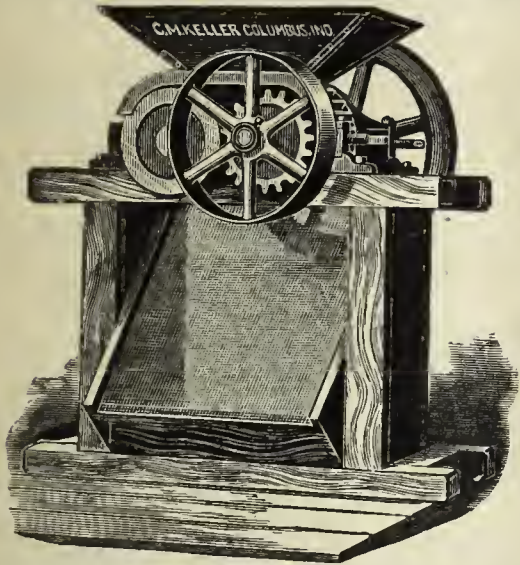

Keller's Adjustable Coke Crusher.

SIMPLE, STRONG, AND DURABLE.

C. M. Keller, Sec. & Supt. Gas Lt. & Coke Co. Columbus, Ind.

Correspondence Solicited.

King's Treatise on Coal Gas.

The most complete work on Coal Gas ever published.

Three Vols. Bound, \$30.

THE PENN GAS COAL CO.

OFFER THEIR

Coal, Carefully Screened & Prepared for Gas Purposes.

Their Property is located in the Youghiogheny Coal Basin, near Irwin and Penn Stations on the Pennsylvania Railroad, and on the Youghiogheny River.

Principal Office:

209 SOUTH THIRD STREET, PHILA., PA.

Points of Shipment:

Pennsylvania Railroad Piers; Greenwich Wharves, Delaware River; Pier No. 1 (Lower Side), South Amboy, N. J.

Chesapeake & Ohio Railway Coal Agency,

FOR THE SALE OF THE

Superior Kanawha Gas Coals, Cannelton Cannel,
Also, SPLINT AND STEAM COALS

From the Kanawha and New River Regions, on the line of the Chesapeake & Ohio R'way.

C. B. ORCUTT, General Agent, - - No. 1 Broadway (Room 217) New York City.

FRANCIS H. JACKSON, Prest. EDMUND H. MCCULLOUGH, V.-Prest. CHAS. F. GODSHALL, Treas. H. C. ADAMS, Sec.

THE WESTMORELAND COAL CO.

Chartered 1854.

Mines situated on the Pennsylvania and the Baltimore and Ohio Railroads, in Westmoreland County, Penn.

POINTS OF SHIPMENT:

PHILADELPHIA, BALTIMORE, SOUTH AMBOY, N. J.,
WATKINS (SENECA LAKE), N. Y.

Since the commencement of operations by this Company its well-known Coal has been largely used by the Gas Companies of New England and the Middle States, and its character is established as having no superior in gas-giving qualities, and in freedom from sulphur and other impurities.

Principal Office, 224 South 3d St., Phila., Pa.

WM. HENRY WHITE,

No. 32 Pine Street, - - - New York City.

ENGINEER AND CONTRACTOR FOR THE

Erection and Extension of Gas, Water, and Electric Light Works.

SOLE REPRESENTATIVE OF THE

McILHENNY REGENERATOR FURNACE PATENTS

And the Martin Water Gas Process.

Edison Incandescent and American Arc Electric Light Plants Installed.

Correspondence with Gas Companies contemplating extending or improving their Plants respectfully invited.
Plans and Estimates Furnished.

GAS METERS.

GAS METERS.

GAS METERS.

JOHN J. GRIFFIN & CO.,

Gas Meter Manufacturers,

Philadelphia, New York
and Chicago,

Will Occupy this Space Hereafter.

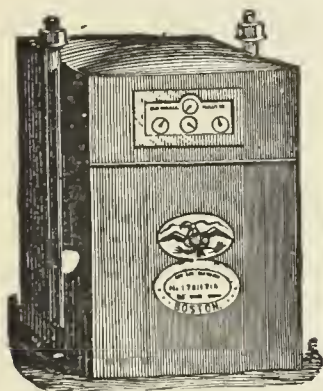

Dry Gas Meters.

With 40 years' experience and the best facilities for manufacturing, is enabled to furnish reliable work and answer orders promptly.

NATHANIEL TUFTS,

No. 153 Franklin Street, Boston, Mass.,

MANUFACTURER OF

DRY GAS METERS.

Station Meters of any Capacity.

Test and Experimental Meters, Pressure Registers, Pressure Gauges,
Pressure and Vacuum Gauges.

METER PROVERS, PHOTOMETERS, STREET LANTERNS, ETC., ETC.

Patent Cluster Lanterns for Street Illumination.

250 & 252
Pearl Street,

JOHN HILLEN'S BROOKLYN GAS METER WORKS.

BROOKLYN,
N. Y.

MANUFACTURER OF

IMPROVED GAS METERS

REPAIRING OF METERS (of all makers) a specialty. All defective working parts are replaced without extra charge. A guarantee is given with all work sent from this shop. Write for Price List.

SCIENTIFIC BOOKS.

We are prepared to furnish to Gas Managers, and others interested in the topics treated of, the following books, at prices named:

KING'S TREATISE ON THE MANUFACTURE OF COAL GAS. Three vols.; \$10 per vol.

GAS MANUFACTURE, by WILLIAM RICHARDS. 4to., with numerous Engravings and Plates, in Cloth binding. \$12.

TECHNICAL GAS ANALYSIS. \$2.80.

GAS CONSUMER'S GUIDE. \$1.

A GUIDE TO GAS LIGHTING. 40 cents.

GAS MEASUREMENT AND GAS METER TESTING, by F. W. HARTLEY. \$1.60

GAS CONSUMER'S HANDBOOK, by WILLIAM RICHARDS, C.E.; 18mo., Sewed. 20 cents.

A PRACTICAL TREATISE ON GAS AND VENTILATION with Special Relation to Illuminating, Heating, and Cooking Gas, by E. E. PERKINS. \$1.25.

PRACTICAL TREATISE ON HEAT, by THOMAS BOX. Second edition. \$5.

GAS WORKS—THEIR ARRANGEMENT, CONSTRUCTION, PLANT, AND MACHINERY. \$8.

COAL; ITS HISTORY AND USE, by PROF. THORPE. \$3.50.

THE GAS WORKS OF LONDON, by COLBURN. 60 cents.

THE GAS FITTER'S GUIDE, Showing the Principles and Practice of Lighting with Coal Gas, by JOHN ELDRIDGE. 40 cents.

GAS WORKS, AND MANUFACTURING COAL GAS, HUGHES. \$2.20.

THE MANAGEMENT OF SMALL GAS WORKS, by C. J. R. HUMPHREYS. \$1.

MANUAL FOR GAS ENGINEERING STUDENTS, by D. LEE, 40 cents.

HOW TO MANAGE GAS, by F. WILKINS. Paper. 20 cents.

THE DOMESTIC USES OF COAL GAS, AS APPLIED TO LIGHTING, by W. SUGG. \$1.40.

DIGEST OF GAS LAW. \$5.

DISTILLATION OF COAL TAR AND AMMONIACAL LIQUOR by GEO. LUNGE. New Edition. \$12.50.

A TREATISE ON THE COMPARATIVE COMMERCIAL VALUES OF GAS COALS AND CANNELS, by D. A. GRAHAM 8vo., Cloth. \$3.

GAS COMPANIES DIRECTORY. \$3.

GAS VERSUS ELECTRIC LIGHT. 50 cents.

THE AMERICAN GAS ENGINEER AND SUPERINTENDENT'S HANDBOOK, by WM. MOONEY. \$3.

GAS ENGINE INDICATOR DIAGRAM, by W. E. AYRTON. Paper. 20 cents.

ILLUMINATING AND HEATING GAS, by W. BURNS. \$1.50.

TESTING PIPES AND PIPE JOINTS, by M. M. PATERSON. 80 cents.

DESIGNING WROUGHT AND CAST IRON WORK, by H. ADAMS. Paper. Three parts, 60 cents each.

NOTES IN MECHANICAL ENGINEERING, by H. ADAMS. \$1.

STRAINS IN IRONWORK, by H. ADAMS. With plates. \$1.75.

The above will be forwarded by express, upon receipt of price. If sent by mail, postage must be added to above prices. We take especial pains in securing and forwarding any other Works that may be desired, upon receipt of order. All remittances should be made by check, draft, or post office money order.

A. M. CALLENDER & CO., 42 Pine Street, New York.

GAS METERS.

GAS METERS.

GAS METERS.

GEO. J. MCGOURKEY, Prest.

WM. H. MCFADDEN, Vice-Prest. (Phila.)

WM. N. MILSTED, Gen. Supt. and Treas. (New York).

WM. H. DOWN, Sec.

THE AMERICAN METER CO.

WET AND DRY GAS METERS.

PRESSURE REGISTERS.

METER PROVERS.

STATION METERS.

PRESSURE & VACUUM REGISTERS.

PORTABLE TEST METERS.

EXHAUSTER GOVERNORS.

PRESSURE & VACUUM GAUGES.

EXPERIMENTAL METERS.

DRY CENTER VALVES.

CRESSON GAS REGULATORS.

AMMONIA TEST METERS.

GOVERNORS FOR GAS WORKS.

MARSLAND WATER METERS.

BAR & JET PHOTOMETERS.

Manufactories:

512 West 22d St., N. Y.

Arch & 22d Sts., Phila.

GAS STOVES.

SUGG'S "STANDARD" ARGAND BURNERS,

SUGG'S ILLUMINATING POWER METER,

Wet Meters, with Lizar's "Invariable Measuring" Drum.

Agencies:

177 Elm Street, Cincinnati.

244 & 246 N. Wells Street, Chicago.

510 North Second Street, St. Louis.

222 Sutter Street, San Francisco.

HELME & McILHENNY,

(Established 1848.)

GAS METER MANUFACTURERS,

Nos. 1339 to 1349 Cherry Street, Philadelphia, Pa.,

WET AND DRY GAS METERS, STATION METERS, EXPERIMENTAL METERS, METER PROVERS,

Center Seals, Pressure Registers, Governors, Indicators, Photometers, and all other kinds of Apparatus for use in Gas Works.

FOULIS' PATENT STATION AND DISTRICT GOVERNORS.

REPAIRING DEPARTMENT.—We employ a special force of skilled workmen repairing meters of all makers.

WM WALLACE GOODWIN, Prest. and Treas.

WM. H. MERRICK, Vice-Prest.

S. L. JONES, Sec.

S. V. MERRICK, Supt.

THE GOODWIN GAS STOVE AND METER CO.,

Successors to W. W. GOODWIN & CO.

1012, 1014 and 1016 Filbert St., Phila., Pa.

142 Chambers St., New York City.

76 Dearborn, St., Chicago, Ills.

WALDO BROTHERS, Agents, 88 Water Streets, Boston, Mass.

MANUFACTURERS OF

DRY AND WET GAS METERS,

Station Meters (square, cylindrical, or in staves), Glazed Meters, King's and Sugg's Experimental Meters, Lamp Post Meters, etc., etc. Meter

Provers (sizes 2, 5, and 10 feet), Pressure Gauges of all kinds, Pressure Registers, Pressure and Vacuum Registers, Pressure Indicators

(sizes 4, 6, and 9 inch), King's Pressure and Vacuum Gauges, Dry and Wet Center Seals, Dry and Wet Governors, Exhauster

Governors, Photometers of all descriptions. Letheby's Sulphur and Ammonia Test Apparatus complete. Also, Testing

and Chemical Apparatus of all kinds, and of the most perfect description, for all purposes relating to Gas.

Manufacturers of the "SUN DIAL" GAS STOVES, for Cooking and Heating.

Goodwin's Improved Lowe's Jet Photometer.

Agents for Bray's Patent Gas Burners and Lanterns.

Special attention to Repairs of Meters and all Apparatus connected with the business. All work guaranteed first-class in every particular. Orders filled promptly.

G. B. EDWARDS, Manager, New York.

S. S. STRATTON, Manager, Chicago.

D. McDONALD & CO.,

GAS METER MANUFACTURERS.

(Established 1854.)

51 Lancaster St., Albany, N. Y.

34 & 36 West Monroe St., Chicago, Ill.

STATION METERS, EXPERIMENTAL METERS, METER PROVERS, PRESSURE & VACUUM REGISTERS, PRESSURE GAUGES, ETC

Also STAR GAS STOVES, RANGES, and HEATING STOVES.

We use only the very best materials, and employ the most skilled labor, and by our long experience (32 years) and personal supervision of every detail, we feel justified in assuring the public that our goods will give perfect satisfaction. Every Meter emanating from our establishment will bear the State Inspector's BADGE, and will be fully warranted by us. Our Annual and Calendar will be sent to Gas Companies upon application.

NEW ONE-THIRD HORSE POWER "OTTO" GAS ENGINE.

Fitted with
TUBE IGNITER,
and of
THE MOST SIMPLE
CONSTRUCTION.

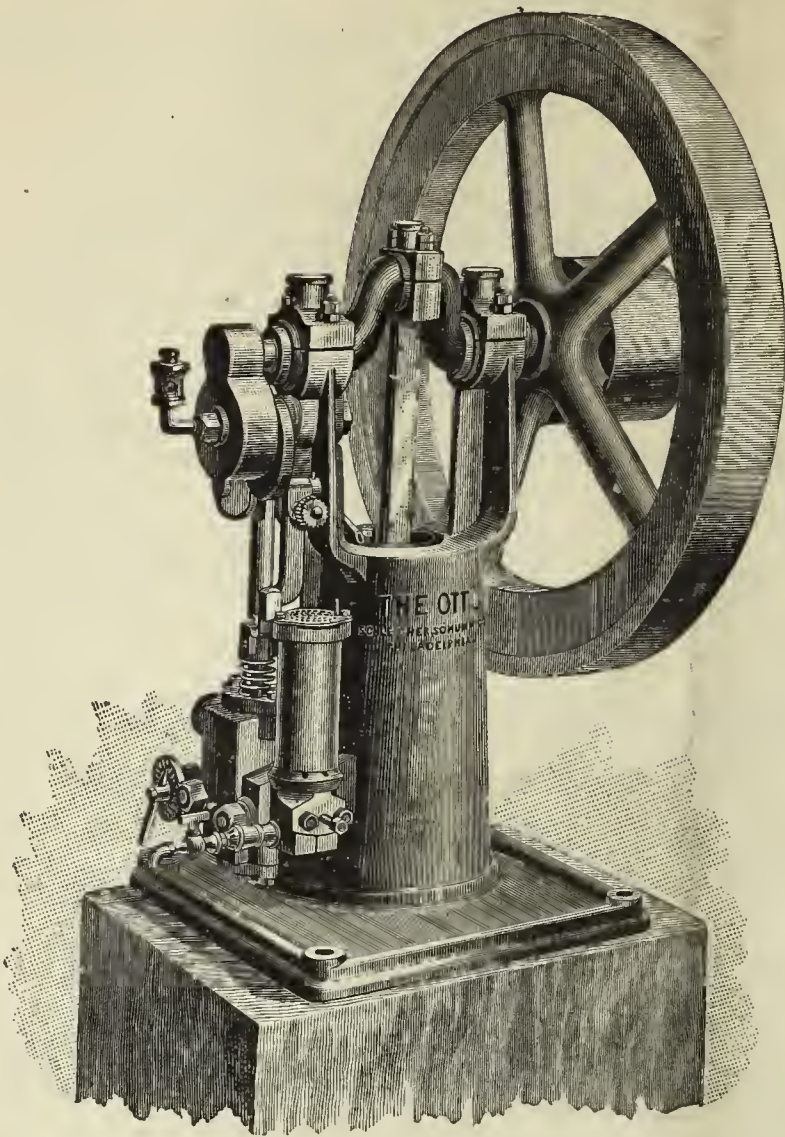

Will Regulate its
GAS CONSUMPTION
in
PROPORTION TO THE
WORK DONE.

Capable of Driving a No. 18 Enterprise or Star Coffee Mill, One Job Printing Press, Three to Four Fans, Dentists' Machinery, Amateur Tools, Household Pumps, Etc.

Many Valuable and Recent Improvements on all other Sizes,

AMONG WHICH ARE

INTERCHANGEABLE DUPLICATES OF SLIDES, PLATES, and COVERS,
Sent with each Engine Free of Charge. Also,

Power in Most Sizes has been Increased, while Floor Space has been Reduced.

SINGLE CYLINDERS AND TWIN ENGINES; HORIZONTALS AND VERTICALS, COMBINED WITH
WATER PUMPS, SEWAGE PUMPS, AIR COMPRESSORS, DYNAMOS, ETC.

Will Outdo in Economy and Every Other Respect the Rented or Electrical Power.

SIZES, 1-3d to 100 HORSE POWER.

"Otto Gas Engine Works,"

SCHLEICHER, SCHUMM & CO.,

151 Monroe St. (Kent Building), Chicago.

33d & Walnut Sts., Phila.

NEW YORK AGENCY, 18 VESEY STREET.

THE AMERICAN

GAS LIGHT JOURNAL

REDMAN & KENNEDY, N. Y.

PUBLISHING OFFICE No. 42 PINE STREET

DEVOTED TO THE INTERESTS OF ILLUMINATION, VENTILATION, WATER SUPPLY AND DISTRIBUTION, & GENERAL SCIENCE.

VOLUME LII.—No. 5. }
Whole No. 765.

NEW YORK, MONDAY, FEBRUARY 3, 1890.

{ \$3 PER ANNUM,
IN ADVANCE.

A. M. CALLENDER & CO., Proprietors. C. E. SANDERSON, Manager.
JOS. R. THOMAS, C.E., Editor. T. J. CUNNINGHAM, Asst. Editor.

ENTERED AT THE POST OFFICE AT NEW YORK, N. Y.
AS SECOND CLASS MATTER.

CONTENTS.

An Asterisk (*) denotes an illustrated article.

OFFICIAL NOTICES—

- Annual Meeting, New England Association of Gas Engineers..... 133
Ohio Gas Light Association..... 133

EDITORIALS—

- Briefly Told..... 134
Mr. Hallett's Success at Springfield, Mass.—Mr. Hallett's Resignation from the Springfield Company—Obituary Note: Wm. Parrish, Seneca Falls, N. Y.—Mandamus Proceedings, Supreme Court, Philadelphia, Decided against Trustees of Roman Catholic High School—Flemming Benches at Philadelphia—Messrs. Connelly & Co. Report Good Business—Annual Meetings.
*Flannery's Patent Gas and Liquid Holder..... 135
*Steel Pressure Blower..... 136
Specific Gravity and Illuminating Power of Coal Gas, by N. H. Humphrys..... 136
The Operation of Felling an Electric Light Pole..... 137
The Dangers of Electric Lighting, by S. Z. de Ferranti and Francis Ince..... 138
The Demand for More Light..... 139
Pile Protection 140
Fifth Annual Report of the Massachusetts Board of Gas and Electric Light Commissioners..... 140
Annual Meeting of the Springfield (Mass.) Gas Company..... 141

ITEMS OF INTEREST FROM VARIOUS LOCALITIES..... 142

A Correction—Tribute to the Late Mr. Forstall—Proposed Purchase by the Borough of the Downingtown (Pa.) Gas and Water Works—Annual Meeting, Peoples Company, Manchester, N. H.—Improvements at Aurora, Ills.—Something from Newport, R. I.—Annual Meeting, Belfast, Me.—Consolidated at Fremont, O.—Annual Meeting, East Boston, Mass.—Calendars Received—The Future of the U. G. I. Company—Hints from Fishkill, N. Y.—Annual Meeting, Warsaw, N. Y.—Charlestown, Mass.—Leaves from History of Providence (R. I.) Company—Letter from Mr. Richardson, Dover, Del.—Chapters from St. Joseph, Mo.—Annual Meeting, Brookline, Mass.—And Many Other Items.

- Recent Patent Issues..... 145

CORRESPONDENCE—

- The Lighting Situation at Fort Scott, Kas..... 145
The Market for Gas Securities..... 146

[OFFICIAL NOTICE.]

New England Association of Gas Engineers.

SECRETARY'S OFFICE, BIRMINGHAM, CONN., Jan. 30, 1890.

The Twentieth Annual Meeting of the New England Association of Gas Engineers will be held at Young's Hotel, Boston, on Wednesday and Thursday, Feb. 19th and 20th. The meeting will be called to order by the President, Mr. Robert B. Taber, on the 19th inst., at 10 o'clock A.M. It can now be definitely stated that the following papers will be read sometime during the meeting:

"Vaporization and Feed of Oil to Generator or Retort," by Dr. Robt. Amory, of Brookline, Mass.

"Management of Small Gas and Electric Light Plant," by S. J. Fowler, of Westfield, Mass.

"A Point or Two in Regard to Illuminants During Condensation and Purification," by George F. Goodno, of Dedham, Mass.

"Notes on Revivification of Oxide," by Waldo A. Learned, of Newton, Mass.

"Various Methods of Introducing Gas Stoves," by H. A. Norton, of Boston, Mass.

"A Few of the Advantages of Water Gas over Coal Gas for Small Works," by F. H. Parker, of Burlington, Vt.

"Why I Shall Make Water Gas," by A. B. Slater, of Providence, R. I.

"A Chapter of Don'ts," by W. H. Snow, of Holyoke, Mass.

"Some Notes Taken in a Small Gas Works," by Ralph Woodward, of Waltham, Mass.

"Problems Constantly before the Gas Manager," by E. H. Yorke, of Brockton, Mass.

In addition to the above there are partially promised several other papers. I think all the members who see this notice will agree that, judging by the above list, the coming meeting bids fair to be a greater success than any of the meetings which have been held in previous years. The topics are quite varied, and many of the subjects are among the most important that gas managers have to deal with at the present time.

The officers of the Association believe that no member of the Association, and no one connected with the active business management of any gas company in New England, can afford to be absent from this meeting. Persons eligible for membership and desiring to join the Association will please apply at once to the Secretary, who will forward them blank applications. Although the membership is large, there are still a good many persons connected with the gas business through New England who do not belong to the Association. It is hoped that all such persons will see fit to join at the coming meeting, and make the Association what it ought to be, truly representative of the gas interest in the New England States.

CHARLES H. NETTLETON, Sec'y.

[OFFICIAL NOTICE.]

Ohio Gas Light Association.

OFFICE OF SECRETARY,
COLUMBUS, O., January 20, 1890.

To Members of the Ohio Gas Light Association:

Gentlemen—The Sixth Annual Meeting of this Association will be held at Toledo, O., on March 19 and 20, 1890.

This announcement is made thus early in order that all members may be reminded of the meeting in ample time to make their arrangements to be present. Every member is urged not only to attend this meeting, but also to interest himself in inducing others of his acquaintance who are eligible for membership, but who have not as yet joined the Association, to come to the meeting and become members.

It is not intended that as many papers as usual shall be presented at the forthcoming meeting, in order that more time than formerly may be had for the discussion of those that are read, and for such other matters and business as the members may desire to dwell upon.

Although the Secretary has for some time been engaged in the work

of soliciting papers for this meeting, he has not yet secured as many as should be had, notwithstanding fewer are desired than heretofore, and he therefore earnestly calls upon all members who can possibly do so to notify him immediately of their willingness to furnish papers.

It has been decided that an interesting and valuable feature of our meeting would be a "Question Box," in which members can place questions, which will be withdrawn and read to the meeting and answered and discussed by the members. Every member is requested to send to the Secretary at once any question or questions which he would like to have thus brought before the meeting.

Future circulars will announce further details concerning the meeting.

Respectfully, IRVIN BUTTERWORTH, Sec'y.

BRIEFLY TOLD.

MR. HALLETT'S SUCCESS AT SPRINGFIELD, MASS.—Our last issue for January contained a paper, read by Mr. J. L. Hallett, of the Springfield (Mass.) Gas Light Company, entitled "Looking Backward," that must have been read with interest by the fraternity, but which also must have afforded them surprise in the nature of the facts recorded. Perhaps no clearer illustration of what may be accomplished in the line of increasing day consumption, by means of well directed and intelligent effort, has yet been put forward in this country than is afforded by the practice of Mr. Hallett at Springfield during the last four years. The figures as given are so concisely arranged, and carry their own story so plainly, that any comment of an extended nature here respecting them would of necessity savor much of reiteration. Yet we cannot help remarking that if the Springfield Company's output of gas for day purposes in the four months named—June, July, August and September—amounts to 10 per cent. of the total output for the year, its manager ought to come in for most hearty congratulation. Adding to this the knowledge that the aforesaid consumption amounts to an increase of 38 per cent. on the total sendout for the particular third of the year to which the tabulation refers, it looks to us that the solution of the fuel gas problem in the East—especially when one remembers in this connection what has been accomplished at Worcester and Lowell, Mass., at Providence, R. I., at New Haven, Birmingham and Hartford, Conn., and at Nashua, N. H.—in so far as the same refers to the domestic phase of the question, is as good as solved. One other striking outcome of the Springfield figures is the large quantity of gas—4,000 cubic feet per month—that is consumed per fixture per month. It is more than likely that many large ranges are in service, which also goes to show that the wealthier class of residents have taken kindly to fuel gas. The story of Springfield's success, so concisely and plainly told by Mr. Hallett, ought to be proof positive to the few remaining "doubters" of the poverty of their belief that there is no great profit in or field for the distribution of gas for fuel purposes by the existing gas companies of the day.

MR. HALLETT'S RESIGNATION FROM THE SPRINGFIELD COMPANY.—Elsewhere in this issue will be found a communication from "Observer," giving a synopsis of the doings at the annual meeting of the Springfield Gas Company. To our intense surprise and great regret we find that the leading feature of the session was the voluntary retirement of Mr. Hallett from all connection with the executive management of the Company. While it is not in any sense an agreeable task to refer to personal differences respecting the management of any business affair, we nevertheless, from an intimate acquaintance with Mr. Hallett, whose calmness of habit precludes the idea that he acted in this case with haste or without sufficient cause for his determination to sever a business relation that covered a period of 25 years, must hold him to have been the injured and aggrieved party. Place without honor and authority is valueless; and Mr. Hallett is not of the caliber of those who can content themselves in a persistent attempt to pose as placid "occupiers of emptiness."

OBITUARY NOTE—WILLIAM PARRISH, SENECA FALLS, N. Y.—Again are we called upon to chronicle the death of a member of the fraternity in the person of Mr. William Parrish, Treasurer and Manager of the Seneca Falls and Waterloo (N. Y.) Gas Light Company. Deceased, who succumbed, on the morning of January 24th, to an attack of pneumonia, was born at Canandaigua, N. Y., on April 23d, 1828, and was educated at the Canandaigua Academy. Having graduated, he visited the West, and on his return therefrom engaged in business at Buffalo, N. Y. In 1868 he succeeded his brother Stephen in the general charge of the Seneca Falls and Waterloo Company, remaining in this position until death severed the connection. Deceased was elected to membership in the American Gas Light Association in October, 1881, and was a fre-

quent attendant at its sessions. He served his Company faithfully and efficiently. His only public office was that embraced in a three years' term as Superintendent of the County Poor, the responsibilities attaching to which were borne in most worthy manner. A local authority, in a sketch of the life of deceased, says: "In his demise our village loses a citizen whose place cannot be easily filled. His many acts of kindness, his genial presence, and his sterling manhood, will long keep his memory green. He was one of the kindest of parents, a loving husband, an obliging neighbor and an accommodating friend, whose death is deeply regretted by the entire community. To the family in their affliction sympathy and condolence will go forth as sincerely from the hearts of strangers as from those of friends."

MANDAMUS PROCEEDINGS, SUPREME COURT, PHILADELPHIA, DECIDED AGAINST THE TRUSTEES OF THE ROMAN CATHOLIC HIGH SCHOOL.—Our readers have from time to time been informed of the various stages of the legal procedure in the case of the Trustees of the Roman Catholic High School, of Philadelphia vs. the Department of Public Works, and in concluding this history we can now say that the Supreme Court has sustained the ruling of the Court of Common Pleas, which was adverse to the Trustees. A summary of the case is that complainants asked for a mandamus requiring the Department of Public Works to make the necessary connections for the introduction of gas into the new Catholic High School, at Broad and Vine streets. The connection and service were refused on the ground that tenants of houses which had been on the site were indebted to the city for gas which they had consumed. The mandamus was asked for on the ground that the Trustees were in no manner indebted to the city for gas, and that no lien existed against land for gas used on premises over it. The lower Court refused on the ground that the ordinance reserving to the Trustees of the gas works the right to refuse to introduce gas into premises until all arrears due on said premises shall have been paid was one which it was within the power of the city to make and enforce. The Supreme Court indorsed this opinion.

FLEMMING BENCHES AT PHILADELPHIA.—The Philadelphia gas works authorities have decided to put in 24 benches of sixes, to be fired under the Flemming plan, at the Point Breeze station. Messrs. Gautier & Co., Jersey City, are to furnish the fireclay materials, the castings to be supplied by Jas. R. Floyd & Sons, of this city. This is good testimony to the value of the Flemming furnace, as the last contract is a sequel to the one awarded a year ago, under which the construction of 24 benches of this type was authorized.

MESSRS. CONNELLY & CO. REPORT GOOD BUSINESS.—Writing under date of January 29th, the Messrs. Connelly & Co., Limited, of this city, say: "Iron sponge is not only holding its own but its use is gradually extending all over the country, and the business increases each year. Our shipments during the present month exceed those of any month in the past, being almost 40,000 bushels, or 45 carloads—almost two carloads for every working day. In automatic governors we have done an unexpectedly large business during the present winter; for gas companies as a rule do not break connections and place machinery of this character during the winter. Notwithstanding this practice we have shipped 12 governors since the first of December; and from the numerous inquiries from all parts of the country we anticipate a regular boom in the enlargement of gas plants next season."

ANNUAL ELECTION, HOUSTON, TEX.—The annual meeting of the Houston (Tex.) Gas Light Company resulted in the following choice of officers: President, T. W. House; Vice-President, T. H. Scanlan; Secretary and Treasurer, G. R. Vaughn; Directors, Messrs. B. A. Shepard, T. H. Scanlan, Jno. T. Brady, Henry S. Fox and T. W. House.

THE works of the Freeport (Pa.) Gas Company were closed on 1st inst. The reason for this is stated to be the competition of natural gas.

ANNUAL MEETING, ILION AND MOHAWK, N. Y.—At the annual meeting of the Ilion and Mohawk Gas Light Company it was determined to construct a gasholder of 50,000 cu. ft. capacity. The officers chosen were: President, Hon. Thomas Ringwood; Vice-President, John Hoefler; Treasurer, C. W. Carpenter; Secretary, John V. Schmidt; Manager, John A. Giblin; Directors, Thos. Ringwood, John Hoefler, John V. Schmidt, C. W. Carpenter, A. N. Russell, F. C. Shepard, M. J. Richardson, Edmund Roche and H. D. Alexander.

THE offices of the Elizabeth (N. J.) Gas and Water Companies have been consolidated. Mr. Thomas P. Smith, for many years Collector for the Gas Company, has been appointed Secretary and Treasurer.

Flannery's Patent Gas and Liquid Holder.

On Jan. 21 U. S. Letters Patent (No. 419,845) were granted to Joseph Flannery, of this city, for improvements in gas and liquid holders. In his specification the inventor says :

The object of this improvement is to provide a simple and ready means for storing liquid, and particularly oil to be used in the manufacture of gas ; to effect a saving of the gaseous vapors arising from the evaporation of the stored oil and prevent the escape of such vapor in the surrounding atmosphere ; to provide means for forcing the liquid stored in the tank, therefore to guard against danger from explosion of the oil, and to effect a saving of ground space over what has heretofore been possible as such storage tanks have been erected. To accomplish these results I place a tank for containing the liquid directly within the the gasholder, whereby the tank will be always surrounded by water, by which the gasholder is sealed, and will therefore be always kept cool, and at the same time so inclosed as to be protected against danger from sparks or other causes which might tend to induce an explosion. I further provide the tank with a vent by which the gaseous vapors arising from the evaporation of oil within the tank may pass directly into the gasholder, thereby not only enriching the gas in the holder and preventing waste, but also providing against the escape of such gaseous vapors into the surrounding atmosphere, as is the common practice, by which the atmosphere is contaminated and the health of a neighborhood

vided with cocks s^1 . D designates a liquid tank, which tank has, as shown, a closed bottom and top, and is secured at its lower side to the bottom of the well C . d d^1 are respectively filling and emptying pipes, by which liquid is delivered to and from the tank D . They are provided with cocks s^2 s^3 . e designates a vent in the upper portion of the tank, by which means open communication is afforded between the tank and the gasholder.

In Fig. 4 I have shown that a float f may be employed, which float is mounted upon a spindle f^1 , extending upwardly through the vent e , and upon which is secured a valve f^2 , adapted to seat upon a valve-seat f^3 ,

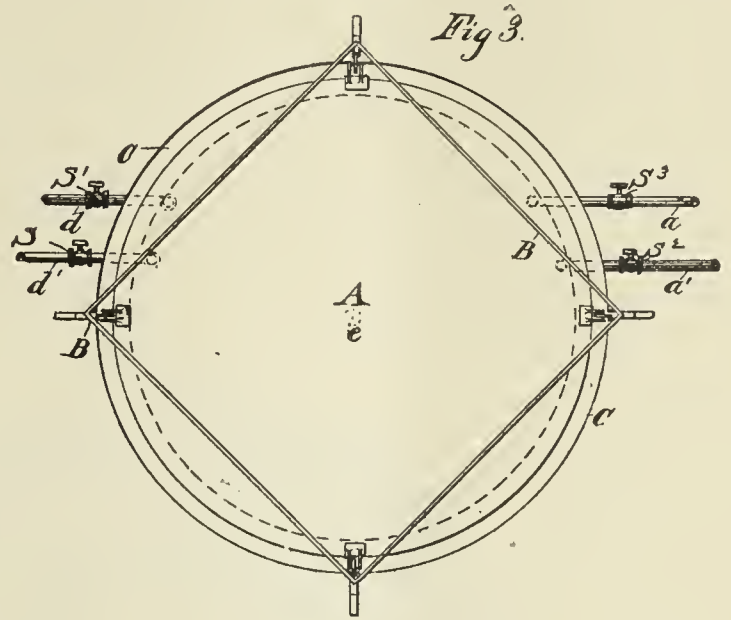
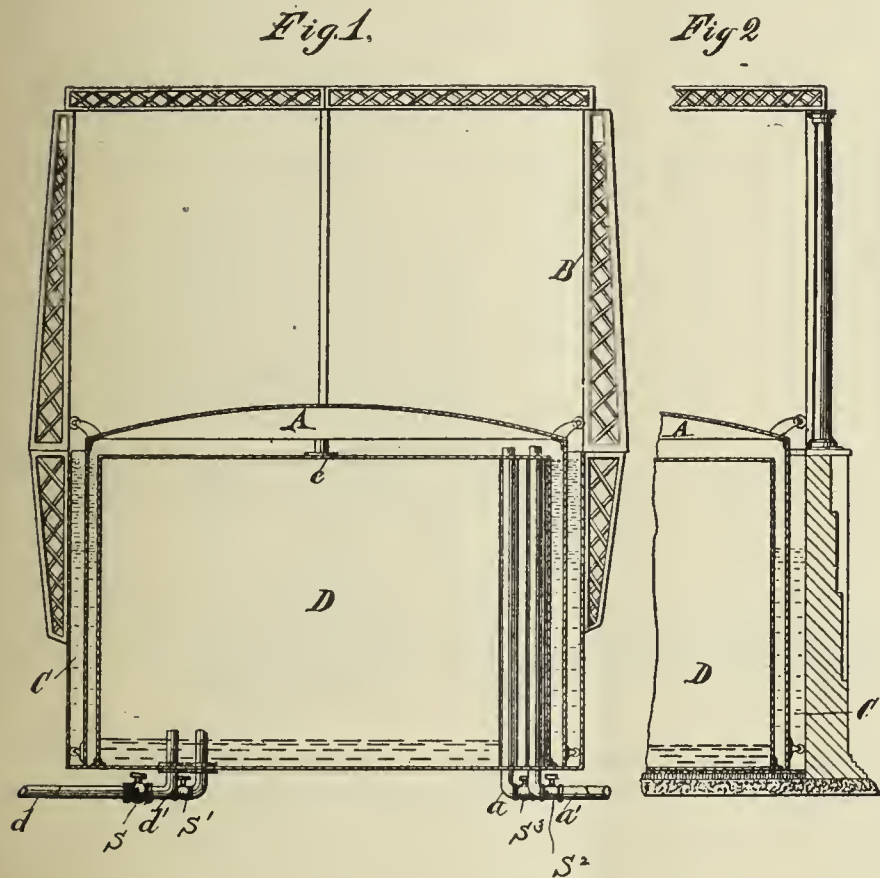

formed upon the inner end of the vent e when the liquid in the tank shall have risen to a sufficient height. This will prevent any overflow of oil into the water space between the tank and the sides of the well when oil is contained in the tank.

In Fig. 1 I have shown the well as made of metal—such as plate iron—and in Fig. 2 I have shown the same as constructed of masonry. In the latter case the bottom of the well is formed of cement or similar material, and the tank D rests thereon.

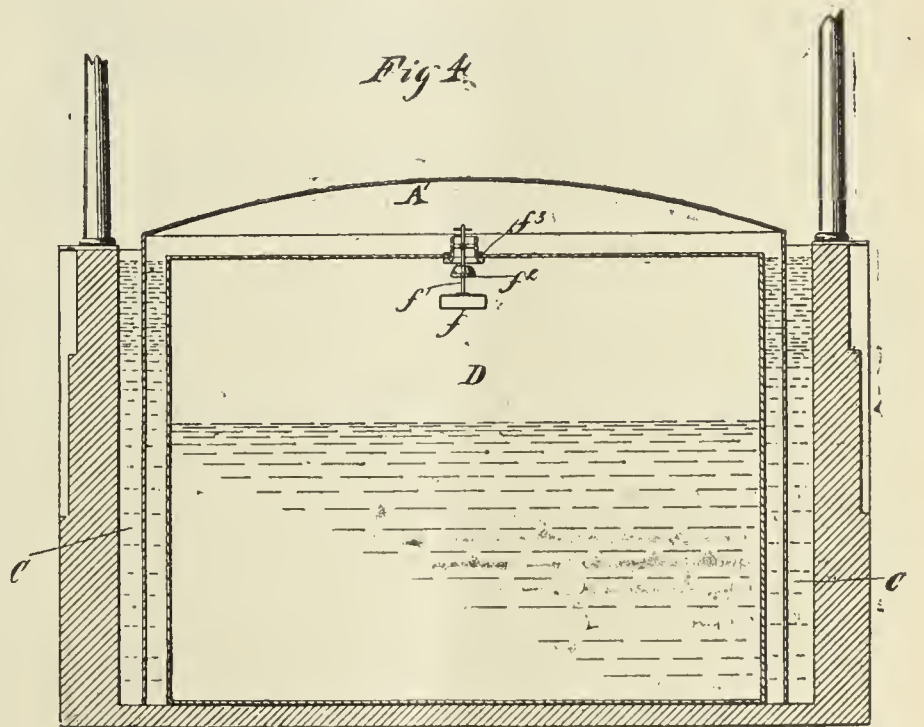

endangered. As the tank is in open communication with the gasholder, in which a heavy pressure is maintained, the weight of the holder and the pressure therein will operate to force oil out of the tank through its delivery pipe, and raise it to a considerable elevation when it is desired to withdraw the oil, the effect being that of a force pump. The arrangement of the tank within the holder will not curtail the gas space of the gasholder, for the reason that the space occupied by the tank is ordinarily filled with water. By placing the tank within the gasholder it will be seen also that a considerable saving is effected in the ground space over what could be effected if the tank and the gasholder occupied different and separate positions.

Gaseous vapors arising from oil stored in the tank will pass out through the vent e , and will become mixed with the gas in the gasholder, thereby enriching such gas and preventing the waste of said gaseous vapors, besides wholly confining them so that they cannot escape into the surrounding atmosphere.

In the accompanying drawings Fig. 1 is an elevation, partly in section, of a gasholder and tank embodying the improvements. Fig. 2 is a similar view, but partly broken away to save space, and illustrating a slightly modified construction. Fig. 3 is a plan or top view of the improvement shown in Fig. 1. Fig. 4 is a vertical section of the tank, and shows a slight modification. Similar letters of reference designate corresponding parts in all the figures.

When it is desired to withdraw oil from the tank, the cock s^3 in the filling pipe d is closed and the cock s^2 in the emptying pipe d^1 is opened. The weight of the gasholder and the pressure therein will then operate to force oil out through the emptying pipe and raise it to a level considerably above the level of the oil in the tank. This is advantageous where the tank and holder are situated at a level below that at which it is desired to use the oil.

A designates the gasholder, which may be of the usual or any desired construction, adapted to be moved upwardly and downwardly in the frame B . C designates the well in which the lower portion of the gasholder is received and in which the water is contained. a a^1 designate gas inlet and outlet pipes, respectively, which may be of the ordinary construction and open directly into the gasholder. They are pro-

Of course, instead of using separate pipes for filling and emptying the tank, both operations might be performed through a single pipe.

Steel Pressure Blower.

The accompanying engraving shows a Buffalo steel pressure blower mounted on an adjustable bed and provided with countershaft. It is designed and constructed with special reference to high pressure duty, such as supplying blast for cupola furnaces, forge fires and sand-blast machines; also for forcing air long distances. By means of a tightening screw the blower may be moved upon the bed while running at full speed, taking up any slack, giving both belts a uniform tension which is regulated at the will of the operator, and is an important point in preventing the inconvenience and loss incurred by a stoppage during heat when blowers are used for cupola purposes. A decided saving by use of the bed is gained in the wear and tear of belts, for a simple turn or two of the nut on the end of the adjusting screw and retightening of the holding-down bolts takes but a moment or two and accomplishes the same end as the relacing of the belts, which usually is put off until the belt will run no longer on account of so much slack. Special attention should be directed to pressure blower belts on account of the high rate of speed at which they must necessarily run, and absolutely perfect alignment of the countershaft with the blower is essential in order to secure smooth running, even tracking, and to avoid undue wear of belts by slipping.

A telescopic mouthpiece is employed in order that the blast piping may not be disarranged in moving the blower on the bed, while suffi-

be eclipsed to the extent of three or fourfold. But so long as the parliamentary standard remains what it is gas engineers will have to make gas that will fit in with the standard, irrespective of its suitability for general purposes to the consumer. Judging from published analyses, a gas that will satisfactorily pass the 16-candle parliamentary standard may vary in composition within the following limits: Illuminants, from 3 to 5 per cent.; hydrogen, from 43 to 53 per cent.; marsh gas, from 35 to 45 per cent.; carbonic oxide, from 3 to 8 per cent.; impurities, such as nitrogen, oxygen, air and carbonic acid, from 2 to 10 per cent. by volume.

There is no reason for supposing that the constituents of coal gas are present in other form than that of a plain mechanical mixture; and it therefore follows that the specific gravity is merely a sum of the specific gravity of the various constituents. The apparent simplicity of this method of arriving at its specific gravity is, however, greatly mitigated by the fact that obtaining an accurate analysis of coal gas is a very difficult thing. Even in the hands of the cleverest chemists it is scarcely possible to entirely exclude calculation. Very few published results are free from the objection that indirect methods of estimation have been resorted to in the case of one or two constituents at least. On the other hand, the accurate determination of the specific gravity by direct weighing is a delicate operation, calling for the best available skill. Not only must there be accurate weighing of the gas, but also accurate reading of the barometer and thermometer, to say nothing of some rather intricate

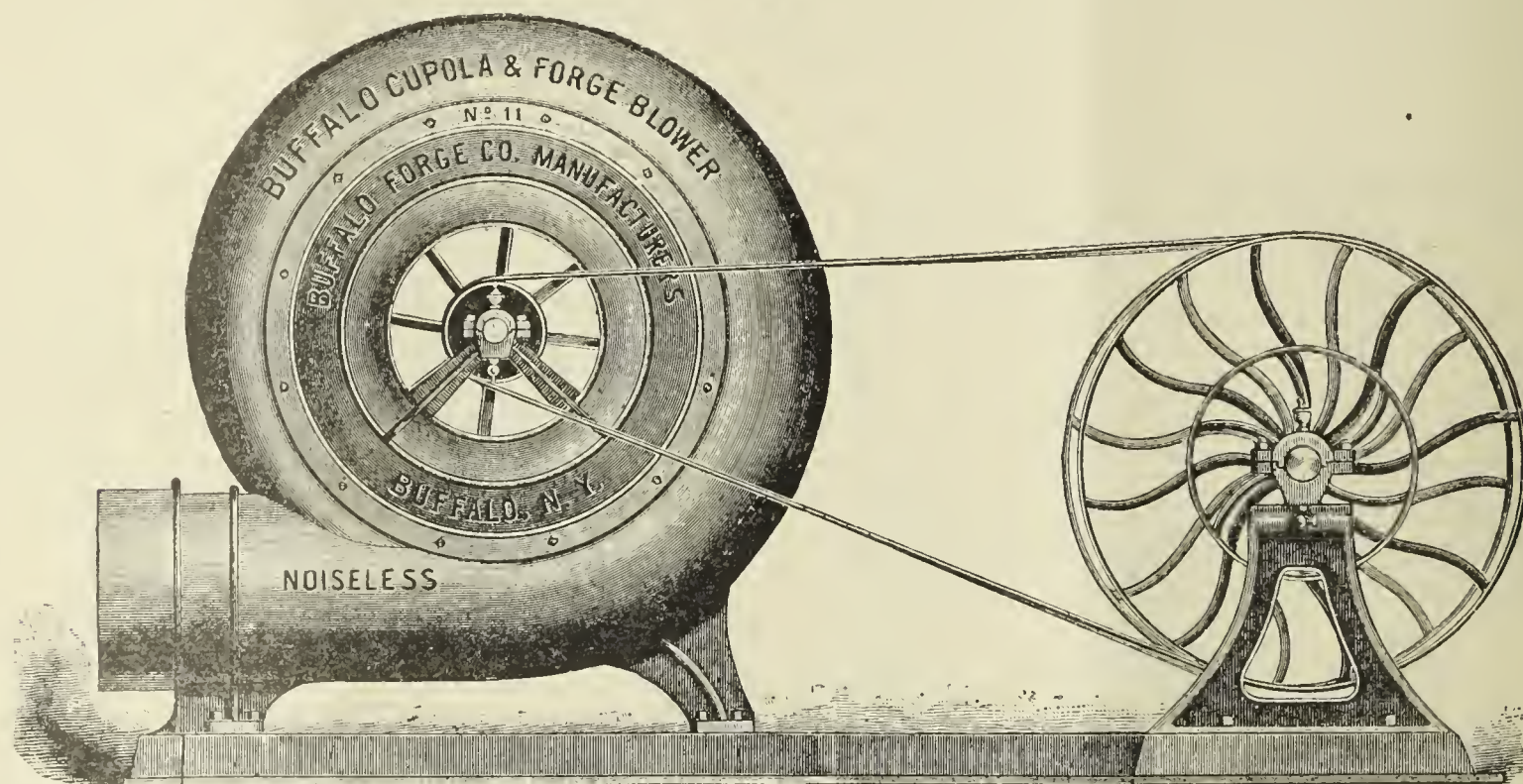

cient length is afforded to the countershaft so that tight and loose pulleys can be used for main driving belt; a self-oiling device fitted to the countershaft enables it to run at high speeds for long periods of time without heating or cutting. A prominent feature of these blowers is the solid case, the peripheral portion of the shell being cast in one solid piece, dispensing entirely with the objectionable "putty joint." Thus, being practically one piece, under the hardest service the bearing must always be in perfect alignment, vertically and laterally, with the rest of the machine. The journals are long and heavy, in the standard ratio of length to diameter of 6 to 1—, with cap bearings secured by bolts screwed in the lower half of bearing held in place by lock nuts.

The Specific Gravity and Illuminating Power of Coal Gas.

[Communicated by NORTON H. HUMPHREYS to the *London Journal*.]

Some little confusion seems to have arisen lately as to the value of the specific gravity test as a means of determining, or rather approximately indicating, the value of an illuminating gas; and it may therefore be interesting to examine some of the principal factors concerned. It should first be specified that the term "illuminating value" is very indefinite. It simply indicates the value of the gas as ascertained by one particular plan—the consumption at the rate of 5 cubic feet per hour in an Argand burner—which may or may not be favorable to the gas under examination. Further, the absurdity of regarding the results thus indicated as anything like an absolute quality of the gas is illustrated by the fact that by means of regenerator and other improved burners they can

arithmetic afterwards. It is not too much to assert that some of the published data on this subject are based upon experiments in which the whole of the above precautions were not rigidly observed. Sometimes, for practical purposes only, a rapid approximate test, such as the diffusion test, is used. In other cases the results quoted are gathered from foreign sources, originated in countries where different standards of temperature and pressure to those used in England prevail. But even after allowing for all these possible sources of error, there still remains a wide divergency to be accounted for.

Owing to the variations in weight, due to changes of temperature and pressure, to which it is continually subjected, it is not usual to give the actual weight of the sample of gas experimented upon. The result ultimately obtained represents the weight of the dried gas under standard conditions of temperature and pressure. And even this is not stated in direct terms, but as a fraction of the weight of an equal bulk of air under similar conditions. The weight of a cubic foot of dry air, at 60° F. and 30 inches of mercury, is about 537 grains; and, therefore, if the specific gravity of a gas is stated as 0.5, the actual weight is $537 \times 0.5 = 268.5$ grains per cubic foot. If this quantity of air has been standing over water it will have taken up about 1.7 per cent. of water vapor, and will weigh rather lighter—about 532.5 grains. But a cubic foot of gas, saturated with moisture, would be rendered rather heavier. The vapor of water at 60° F. is lighter than air, but not so light as coal gas. The reason for taking the weight of the dry gas is that the water vapor varies according to temperature and pressure.

If the several constituents present in coal gas were about equal in the

matter of specific gravity, a moderate variation in constitution would not have much effect as regards the weight. But, as a matter of fact, they vary over a wide range, as shown by the following table, which gives the principal constituents of coal gas, their specific gravity, weight of a cubic foot in grains, and ratio to an assumed specific gravity of 0.45, or 242 grains, which may be taken to represent that of 16-candle gas :

	Specific Gravity.	Weight in Grains.	Ratio.
Hydrogen.....	.069	37	0.15
Marsh gas.....	.553	300	1.20
Acetylene.....	.898	482	1.99
Carbonic oxide.....	.967	519	2.14
Olefiant gas.....	.968	520	2.15
Nitrogen.....	.971	521	2.15
Air.....	1.000	537	2.22
Oxygen.....	1.106	594	2.45
Carbonic acid.....	1.520	821	3.39
Benzene.....	2.695	1,445	5.97
Naphthaline.....	4.423	2,372	9.58

The highest constituent present is hydrogen, which is less than one-sixth the weight of the gas. It is rather singular that this is the only constituent that is lighter than the mean—all the rest being heavier; and with the exception of marsh gas nearly twice as heavy, and upwards. Several of the constituents are near the twofold limit; then there is carbonic acid; and lastly, the heavy vapors of benzene and naphthaline.

Assuming that the gas of 0.45 specific gravity contained the lower limit of hydrogen (43 per cent.) the effect of adding another 10 per cent. would be as follows :

$$\frac{(.45 \times 10) + .069}{10 + 1} = .415$$

making it lighter to the extent of nearly 8 per cent. Or the effect of taking away 10 per cent. would be :

$$\frac{(.45 \times 10) - .069}{10 - 1} = .492$$

an increase of nearly 10 per cent.

The addition of 10 per cent. of marsh gas would raise the specific gravity :

$$\frac{(.45 \times 10) + .553}{10 + 1} = .460$$

and taking away a similar quantity would lower it :

$$\frac{(.45 \times 10) - .553}{10 - 1} = .439$$

In a similar manner the effect of variation in the proportion of carbonic oxide can be arrived at. The addition of 5 per cent. of this gas would raise the specific gravity thus :

$$\frac{(.45 \times 100) + (.967 \times 5)}{100 + 5} = .474.$$

Or the deduction of a similar quantity would lower it :

$$\frac{(.45 \times 100) - (.967 \times 5)}{100 - 5} = .423.$$

From these calculations it is plain that variations in the proportion of hydrogen and carbonic oxide, which need not necessarily exert any marked influence on the photometrical value of the gas, may alter the weight and specific gravity to the extent of 10 per cent. or more in either direction.

Although the illuminants are present in small proportion there is reason to believe that they are certainly not less than four, and perhaps as much as five times as heavy as the mean. But in their case there is a compensating cause. If they are small in quantity, they must be heavier, and therefore richer in quality. It was this consideration that led Mr. Lewis Thompson to suppose that in gases of equal illuminating value the *weight* of the illuminants, which is a very different thing from the percentage by volume, would also be practically equal. Scientists and others who talk about coal gas being only charged with a trifling proportion of illuminants, have probably overlooked the fact that it consists of heavy hydrocarbons to the extent of 20 to 25 per cent. by weight. The 10 cubic feet of the gas above referred to would weigh 2,420 grains; and if it contained 5 per cent. of hydrocarbons, of which the average specific gravity was 2, the weight would be 537 grains, or more than 22 per cent.

But the chief cause of variation in specific gravity is the presence of impurities, such as nitrogen, oxygen, air, or carbonic acid. Not only do these range from 2.2 to 3.4 times the weight of the mean, but there is the important fact that an additional weight of illuminants must be present in order to make up for the depreciating effect of the impurities on the illuminating power. The removal of such impurities would cause

an important increase in the photometrical value; and therefore a 16-candle gas containing appreciable quantities of them is, to all intents and purposes, an adulterated 17, 18, or 19-candle gas, according to the proportion present. The removal of the impurities would also be attended by a reduction in the specific gravity and at the same time improve the illuminating value of the gas.

The most common impurities of this class are nitrogen and carbonic acid. The former is very slightly heavier than carbonic oxide; so we may apply the calculation for that substance to it, and say that variations to the extent of 5 per cent., either way, in the proportion of nitrogen present, would cause the specific gravity to range from 0.423 to 0.474. The effect of carbonic acid is very similar; for although it is present in smaller quantities, its specific gravity is high. In towns where the sulphur clauses prevail this impurity must of necessity be removed from the gas. In other places, for reasons which need not here be entered upon, there is as much as 2 per cent. of carbonic acid in the gas. Applying the above form of calculation, we shall find that 2 per cent. of carbonic acid added to the gas increases the specific gravity to 0.480; or a similar quantity deducted from the gas will reduce the specific gravity to 0.424.

It appears that within the variations in constitution that are found to occur in the ordinary way of manufacturing gas from coal, the only constituent that is not likely to exercise an important influence on the specific gravity is marsh gas. This will probably not affect it to the extent of more than 2 per cent from the mean in either direction; whereas the others range from 5 to more than 10 per cent. With the exception of the illuminants there is no reason to suspect the existence of any compensating influence—*i.e.*, that the presence of a large proportion of any one constituent must necessarily result in the presence to a correspondingly small proportion of any other one; though, of course, if one is high, the others as a whole must be correspondingly less. In order to confine the specific gravity within reasonable limits of accuracy as an indicator of photometrical value it is necessary that the proportion of hydrogen and carbonic oxide present should not vary beyond narrow limits; and also that nitrogen, oxygen and carbonic acid should be conspicuous by their absence. If so much difference exists between samples of illuminating gas made on the same system, by the destructive distillation of coal, a much greater difference may be expected to obtain between the specific gravity and photometrical value of other kinds, such as oil gas, wood gas, or carbureted water gas.

The Operation of Felling an Electric Light Pole.

An observant New Yorker, in recounting some of the sights that attract crowds of the curious in this city, says that for several months past New York city has been endeavoring, through its authorities, to do away with all electric conductors stretched upon poles, and to compel the placing of them in so-called subways in the streets. The city, in carrying out this work, has frequently been called upon to take down a pole so located that the placing of it in a horizontal position called for nice judgment and well adapted rope connections. How these poles are taken down when they must be felled in exactly the right position, or in other words, when the top of the pole must not vary 4 feet from the line it stood in, are questions which of course interest every one. The method of taking down a pole, therefore, which stood between the elevated structure in Church street, and from which structure the house line of the building was not more than 7 feet away, presents points of general interest. After this pole had been relieved of its cross bars and all wires connected with it, it was stayed at the bottom with four ropes placed at right angles to each other and attached just above the cut. These ropes were intended to prevent any movement or jump of the butt of the pole. It was then provided with three ropes about midway between the top and the bottom, one of which was so arranged as to guide the descent of the pole, the other to prevent the pole falling in the opposite direction, and the third to insure the pole falling in a line with the elevated road.

The cutting of the pole at the base, evidently done by a backwoodsman, since he handled his axe with a degree of precision not found in the city, was begun on that side toward which it was desired to fell the pole. After he had cut beyond the center of the pole he began work on the opposite side. As he approached the dividing line between his cuts all ropes were tightened. Thus the butt of the pole by its four ropes was prevented from any jumping, and also the top of the pole was prevented from striking the building, where it might have done some damage, by the rope connected with the elevated railroad, and it was also prevented from falling too fast in either direction by ropes which extended parallel with the elevated structure. After he had cut about half way through this side of the butt of the pole, the rope was hauled on that side to

which it was desired the pole should lean, and as the pole gave way to this pressure the rope upon the opposite side was played out, while that toward the elevated structure was so guided that the pole just missed the cross ties; and in this way was lowered to the street without any hitch whatever, and without deviating 12 inches from the line it should have followed. The system of taking down poles, as developed here in New York, shows that by the simplest means any pole can be felled and carried down within the closest limits; in other words, as was the case with the pole above mentioned, it can be taken down by an elevated structure projecting over the sidewalk and between the buildings on the line of the sidewalk, and yet can be done easily and gently and without in any way interfering, beyond a few minutes, with travel on the elevated road or on the sidewalk.

The Dangers of Electric Lighting.

BY S. Z. DE FERRANTI AND FRANCIS INCE.

[These authors have prepared the following review (for *Engineering*) of the dangers of electric lighting. The concluding portion will be given in our issue for February 10th]:

The time has now arrived when it is absolutely necessary for the public generally to clearly understand one or two matters connected with electrical science, and we propose to explain to the uninitiated certain electrical terms, and, having explained them, to show what are the "dangers of electric lighting," whether a high tension or a low tension system is used.

In the first place it is of primary importance to understand that, when dealing with an electric current, two things require immediate attention; first of all, the "tension" or "pressure" of the current; and secondly, the "quantity," and to understand fully the meaning of the terms pressure and quantity, take water by way of illustration. With water no one has any difficulty in understanding that, with a pipe of a given size, and with water flowing through it from a cistern placed 20 feet above it, a certain quantity of water would flow through the pipe in a minute; but if the cistern were then placed 40 feet above the pipe, a considerably larger quantity of water would flow through the same pipe in a minute, this result being brought about by the extra pressure due to the water falling through 40 feet in lieu of 20 feet. Tension or pressure of an electric current, technically called "volts," may be taken as similar to water pressure. Now, with regard to quantity, here again a pipe of a certain size will, at a given pressure, allow a certain quantity of water to flow through it in a given time, and if the water pressure be doubled, about twice the quantity of water will flow through it in the minute. So again with the electric current, if a conductor, or bar, or tube of copper of a given size be taken, the quantity of current which will pass along it varies with the pressure; that is to say, that if the current is sent into the conductor with a pressure we will call one, a given quantity of current passes along the conductor in a minute, and if we have a pressure of twice one, or two, twice the quantity of current will pass along the conductor in the minute. Quantity is technically called "amperes."

We will now pass to another matter; we must consider what work—or useful energy—can be got out of a current. This is arrived at by multiplying the pressure and the quantity together, and the result is called "watts," and watts, therefore, represent the actual work—or energy—any given current will give. Now let us explain clearly what this means. A horse power is a power capable of raising a weight of 33,000 pounds 1 foot high in a minute, and to perform this work 746 watts are required, that is to say, the pressure of an electric current multiplied by the quantity must give the answer 746 to make the electric power equal one-horse power; thus a current with a pressure 1 (1 volt) and with a quantity 746 (746 amperes) will equal one-horse power, or a current with a pressure 2 (2 volts) and with a quantity 373 (373 amperes) will also give one-horse power, as $2 \times 373 = 746$; or again, if we have a pressure of 746 (746 volts), and a quantity of 1 (1 ampere), the two multiplied together still give 746, and thus we should still have a power equal to one horse.

Now, it will be remembered that when dealing with water passing through a pipe, the quantity passed in a minute was about doubled if the pressure was doubled; therefore if you wish the pipe only to deliver a certain quantity of water in a minute or to do a certain work, the size will be reduced, if your pressure is increased. So with electricity, if you increase your pressure you decrease the size of your conductor, as the quantity of electricity always passing will be less, to do certain work.

To make ourselves clear, let us give an illustration: The pressure at high electricity is used ordinarily for lighting incandescent lamps is

100 (100 volts), and the quantity of current a 10-candle power lamp consumes is .35 (about $\frac{3}{10}$ of an ampere); therefore to light 5,000 of such lamps a current is required at the constant pressure of 100 (100 volts) and the quantity that would be required is $5,000 \times .35$, or 1,750 amperes, the energy consumed in watts being equal to the pressure (100 volts) multiplied by the quantity of 1,750 amperes, the result is 175,000 watts.

Thus to light 5,000 lamps, the current being sent out from the central station at a pressure of 100 volts, a conductor would have to be provided which would carry in quantity 1,750 amperes; thus the pressure $100 \times$ by the quantity 1,750 gives 175,000 watts, the power required to do the work. Now, if the current were being sent out from the central station at a pressure of 10,000 volts, a conductor would have to be provided which would carry in quantity 17.5 amperes only; thus again the pressure $10,000 \times$ by the quantity 17.5 would again give 175,000 watts, the power required to do the work, and the size of the conductors required therefor in the two cases to do the same work would be in the proportion of 1,750 to 17.5, that is to say, that with a pressure of 10,000 volts the size of the copper conductor would be about one hundredth of the size required if dealing with 100-volt current only.

It is now only necessary for us to point out one other scientific fact, and we shall then be in a position to clearly consider "the dangers of electric lighting;" that fact is that for heating purposes the quantity of the current only has to be considered, and not the voltage or pressure, as it is the passing of too great a quantity through a conductor that causes it to heat, and ultimately to melt, irrespective of the voltage or pressure, which has nothing whatever to do with heating. A pipe, if too much water for its strength was being forced through it, would burst; the electrical conductor with too much quantity through it heats and ultimately melts. Thus, if a conductor is put under ground of a size sufficient to carry current for 5,000 lamps only, and we turn on 10,000 lamps, the conductor will heat, and if we go on turning on more and more lamps, the conductor will ultimately melt at the weakest point. When the continuity of the conductor will be broken, no more current will be passed, the lights go out, and no further danger exists. Now, besides giving a conductor too much work by putting on too many lights, there is a second way in which an underground conductor may be made to do too much work, and so to heat or melt—that is to say, if the conductor is so constructed that it can, and is so placed in the ground that it may, and it does, come into contact with another conductor, such as a telephone or telegraph wire, a gas or water pipe, the current will leak into and through such other conductor, and will find a short way back to the central station from whence it came in preference to going through the lamps or doing other work, the resistance in going back through the earth by the short cut being less than the resistance of the work to be done; just in the same way if a pipe bursts, the water will spout out at the burst point in every direction, as the resistance is less at that point to the water than the resistance in the further length of pipe, if the water were to proceed to do its work; again, as before pointed out, the pipe bursts under the pressure, but the main at the point of contact with another main or wire, where the rush of the current takes place, heats, and finally melts, setting fire to or melting anything in its neighborhood. Here is the danger of fire. Now let us see how this danger is got over in this country. As before pointed out, if too many lights are put on any main, or conductor, the main heats and finally melts at the weakest point; and in the second case, where the conductor comes across another conductor, as above pointed out, there is an enormous rush of current through the conductor, it heats and ultimately melts at the point of contact. Now, how is this danger to be entirely got rid of? The question is in fact answered by the above statement, which must be clear to any one, that when too many lights are turned on the conductor heats and melts at the weakest point.

What have we to do, then? We place at our central station, close to the dynamo which generates the current, the weakest point in every main or conductor that leaves the station; this weakest point is a short bridge of copper so slight and of a so carefully calculated capacity that if a conductor is of such a size that it should be used for lighting 5,000 lights only, if 6,000 lights are turned on the rush of current is too great for the bridge, and it melts or fuses (hence the bridge is technically called a fuse), and that main or conductor is cut out long before any part of it even becomes warm. But you say, What occurs if it is not too many lights that are turned on, but is a contact, as suggested, with another conductor or a gas pipe? Consider for a moment what happens at the point of contact; there is a too great rush of current to that point, and the result therefore is the same as turning on too many lights; if there is too great a rush of current from any cause it must all pass over the bridge into the conductor, and the bridge cares not for the reason that causes the great flow, but the great flow instantly causes the bridge

to fuse, and with a conductor so arranged accident by fire is an impossibility. Mr. Edison has said, in a recent article by his pen on the same subject as that on which we are writing, that "near the corner of William and Wall streets, New York, the underground conductors of the Edison Illuminating Company became crossed (by which he means they came in contact), and the current which was passing through them at a pressure of 110 volts melted not only the wires but several feet of iron tubing in which they were incased, and reduced the paving stones within a radius of 3 feet or 4 feet to a molten mass." Now no man knows better than Mr. Edison that the tension of the current in the mains to which he refers had nothing whatever to do with the heating effect of the current; it was the quantity, and the quantity alone, that caused the heat. Now, if his main were lighting 5,000 lamps of 10-candle power at 110 volts, the quantity of his current would have been, roughly, about 1,700 amperes, and by the contact, this quantity would have been enormously increased, whereas if he had been using a 10,000 volt current his quantity, as we have seen, would have been only 17 amperes about, and the heating power of his current would have been 100 times less; but where was Mr. Edison's bridge or fuse at his central station?

It is clear that he could have had none, or it would have melted before any damage could by any possibility have been done; and his statement proves, as the reader will see, not that a higher tension would have been more dangerous (it would have been safer), but that the work at the station to which he refers must have been done on most incorrect and inefficient principles. Mr. Edison may argue that with increased pressure it is possible to force a greater quantity through a main, and that therefore a 10,000 volt pressure is more unsafe than a 100 volt pressure; but this is not the fact—as the conductor to be melted is in size only one hundredth of the size of his main it will heat and melt sooner, and there is not the same quantity of molten mass to deal with; but the real answer is, that the bridge or fuse at the station, if used, is, with either low or high pressure, the real safety, as it will never allow so large a quantity of current to pass over it as is necessary to cause the conductor to heat, no matter whether the pressure be 100 or 10,000 volts. Take again the calorific effect of the low tension system. We have seen that to do the same work, the low tension system requires 1,750 amperes against 17.5 on the high pressure, and thus if an accident does happen on the low tension system, the immediate calorific effect of 1,750 amperes is called into play. Now, if on the high tension system such an effect could be reached, our engines would be called on to do an absolute impossibility, as they would be required to give 100 times their nominal power before the quantity and equal heating effect of 1,750 amperes could be reached.

Then comes the further question, How did Mr. Edison's mains become crossed, or rather in contact, with another conductor crossing his mains at right angles apparently at a street crossing? This must have arisen through the negligent way in which the Edison mains were placed underground without sufficient protection. It is idle to suggest that this is a danger that cannot be guarded against. It is easy enough to protect one conductor underground from coming in contact by any possibility with another crossing it, and we should be wasting the reader's time if we were to attempt to describe the thousand and one ways in which this may be done, for many will suggest themselves to every reader. But the further question arises, Is it not possible to construct your mains or underground conductors in such a manner that the passing of another main or conductor at an angle above and in contact with it will produce no harmful result whatever? The answer is Yes, distinctly yes.

(To be continued.)

The Demand for More Light.

The *Gas World*, in commenting on the demands for more light, says that in mentioning Bristol as a town where talk about "bad" gas has been somewhat prevalent during recent months we do so only to direct attention to the growing desire of the general public for more light. A decade ago a light that would make darkness visible was considered good enough; and any company seeking parliamentary powers was seldom asked to bind itself to the supply of gas of more than 13 or, at most, 15-candle power. The Bristol United Gas Light Company, working under Acts obtained many years ago, is legally bound to supply gas of only 13½-candle power, and very few English companies are called upon to supply 16 candles. That is the full pound of flesh the public can demand, but, as a matter of fact, very little gas is supplied in this country under 16 candles. The Bristol Company, while it may with impunity supply 13½-candle gas, actually supplies 16-candle gas; and as in Bristol so in nearly every other town and village throughout

England. Yet, notwithstanding this generous interpretation of the bond by the gas companies, the continuous cry of the public, or rather of the public's representatives in council assembled, is "give us more light." To have a "dim religious light" in the streets is not sufficient for the present generation; the light of to-day must be brilliant and all pervading. If we were asked to state what has brought about this change in the public taste, we would say, naming the causes in order of merit, (1) the desire to improve upon the achievements of the past; (2) the example of private enterprise; (3) the impression left upon the public mind by a passing acquaintance with an arc lamp. In an age which we are proud to call an age of progress the desire to improve the public lighting of our streets is a perfectly natural one; a comparison between the general lighting of the streets and that of the outside of an enterprising tradesman's shop (a comparison which most of us involuntarily make every day of our lives) shows that such improvement is, not only possible, but ridiculously easy of accomplishment; and the electricians are continually pushing their arc lamps under our noses, as much as to say: "If the gas companies won't satisfy your desires, we will."

But here the trouble arises. The public wants more light, and because it does not get it, says the gas is "bad." As we have already said, the gas is better in quality than the requirements of the Legislature demand; so to be honest the public must either give up the cry of "bad" gas or set about mending the legislation under which it is permitted to be "bad." There is no medium course so far as the quality of the gas is concerned. But before hastily amending the legislation we would recommend those who are dissatisfied with 16-candle power to see how "bad" even 30 candle gas can be made to appear. We were recently passing through the Fair City of Perth after the sun had set upon its fairness, and although gas of nearly 30-candle power was being burned in the street lamps, the streets would have had anything but a pleasing appearance had it not been for the light streaming forth from the shop windows. What the city is like after the shops are closed we did not wait to see. When this is the condition of affairs where the gas is 30-candle power it must become apparent to the most enthusiastic anti-gas municipal ruler that deficient street lighting cannot be wholly attributable to the low illuminating power of the gas. He may even begin to suspect that the fault lies with his own method of using the gas supplied to him. If he does so there is hope, for he is now on the right path toward improvement.

You cannot light a palace with a candle; neither can you light 30 yards of street by the combustion of 2½ cubic feet of gas per hour through an antiquated burner. The man who attempted the former would be called something not very polite. The latter is equally impracticable, but when the inevitable failure ensues the gas is "bad!" All this cry about "bad" gas is simply beating the air. The public wants more light—there cannot be a doubt about that—but for its new requirements the public must pay—either by paying the extra cost of a higher illuminating power or by consuming more of the present quality gas by means of improved apparatus. Gas companies are paid for providing a certain quantity of light; they cannot be called upon to supply double, or any other multiple of that quantity for the same money. Municipal rulers must therefore face the inevitable by providing the extra money required to pay for the extra light demanded by their constituents. This extra light can, as we have indicated, be obtained in two ways—by increasing the illuminating power of the gas and adhering to the present consumption per lamp, or by increasing the consumption and adhering to the present illuminating power. To our mind the latter course is the proper one to pursue. By increasing the illuminating power you cannot afford that distribution so essential to street lighting, and you also compel the private consumers to pay an extra penny or twopence per 1,000 cubic feet (as the case may be) for an extra illuminating power which many of them do not desire. By adhering to the present quality and increasing the consumption you can distribute the light more evenly, and obtain a higher yield of light per cubic foot of gas consumed by taking advantage of the well known law that within limits the greater consumption in an individual lamp the greater the yield of light per cubic foot of gas. Indeed, under this law you obtain light for which the gas company does not get a farthing.

The subject is one which demands the most careful consideration by those charged with the lighting of our streets. We do not now put the case as one of gas *versus* the electric light; we are simply dealing with the growing demand for "more light." To satisfy that demand will cost money—whether the result be obtained by a more generous and scientific use of gas or by the introduction of the electric light. That gas can satisfy the demand is abundantly proved by what has been done in different corners of London, in Brighton, and in every town where a gas

installation has been fitted up under the eyes of competent supervisors. That the electric light can satisfy it has yet to be proved. In Barnet and in Leamington the incandescent electric lamps have been woeful failures (both financially and practically); and any one who has had experience of the arc lamp must admit that its distributive and diffusive powers are not of a very high order.

Pile Protection.

Mr. J. A. Pritchard not long since read before the Ohio Society of Surveyors and Civil Engineers a very interesting paper on the subject of "Pile Protection." An extract of this paper is appended:

It has been a study with landowners along the streams (I would add here by way of parenthesis that I refer to those who believe in taking care of land, and not those who allow things to go to rack) to devise some effective and cheap method of protecting banks and levees. Some have tried to do this by building cribs of round timber and filling with brush and boulders. These caused the wash to be more instead of less, and were considered failures. Others have built brush dams, excavated new channels and changed the course of the stream. While one attempt at this was successful others failed, and the expense of making a new channel was considerable. In the fall of 1887, there was commenced a system of pile protection, of which there was put in at that time 742 feet in all, which consisted of three wings, and 546 feet, which was in one continuous curve of about 475 feet radius, the piles of which were driven close up to the bank and sheeted on the water side with 2-inch oak sheeting. But it is the wings that I wish to speak of, as to place a continuous sheet along the water front of a large farm that is liable to wash would be rather expensive. The wings are constructed in the following manner: No. 1 is located where the creek makes a curve of 800 feet radius, and consists of thirteen piles seven feet from center to center, seven of which were driven close up to the bank. The remaining six were placed across the stream at an angle of 45°. Brush was then laid across the line of piling well out into the stream. The bottom plank of the sheeting was then forced down on the brush and made fast by 6-inch wire spikes. The sheeting was placed behind the piles on the bank part, and is held in place by a back filling of brush and gravel. On the part which extends into the stream, the sheeting is placed on the front or upper side, and is secured to the piles by 6-inch wire spikes. The top piece of sheeting is made double, and in such a manner as to break joints, and is bolted with $\frac{1}{2}$ -inch bolts, two to a pile. The extreme 35 feet which extends into the stream is double sheeted, and in such a manner as to break joints between the piles, and is bolted at the joints to a 4-inch by 6-inch stay, placed behind the sheeting, with $\frac{1}{2}$ -inch bolts. The piles were driven by horse power with an 800-pound hammer. The leads were placed on a common farm wagon, and were about 16 feet full length. The length of this wing is 84 feet. An estimate of the cost would be:

Thirteen piles, fourteen feet long, at \$1.50..	\$19.50
Driving same, at \$1.50.....	19.50
Boarding three men and team..	5.00
Sheeting, 1,320 feet, at B. M. \$68 per 1,000..	24.90
Placing sheeting and back filling.....	10.00
Bolts and spikes	3.00
Total.....	\$81.90

I would here say that the cost of the whole 742 feet was between seven and eight hundred dollars, or about one dollar per foot. The effects of this wing has been to protect the bank for about 400 feet, at which point the wash originally began, on the opposite side, but since the wing has been placed has begun further up the stream. It also had the effect of deepening the channel, which before was about 2 $\frac{1}{2}$ feet and now is 4 $\frac{1}{2}$ feet deep. Wings Nos. 2 and 3 are built in the same manner, but with a more favorable location and 28 feet less in bank part. No. 3 failed, the stream end having washed out when the ice broke up in the spring of '88. The depth of water where it stood is now about 11 feet. Wing No. 3 is 190 feet below No. 2, and the current does not strike the bank between them, although they are on a curve with a radius of 475 feet. One hundred and sixty feet from wing No. 3 the continuous sheeting begins. My opinion is that the better practice would be to cross the current at an angle not to exceed 20°, and continue the wings 20 to 30 feet further, according to circumstances, and the piles should be longer than those used in this case, and be driven lower, so that when the ice breaks up, that with a moderately high water it could flow over the top of the wing. And there should be two piles driven from 8 to 10 feet back of the wings, and two heavy round timber braces placed at the end pile and the third from the end to insure stability, as the weight sustained during an ice gorge is tremendous. I am not aware that any engineer was called on to

plan or locate the work that has been done, but I think that by being properly located, that a wing, not to exceed a cost of eighty dollars, can be made to protect a bank from 200 to 500 feet, according to the curvature of stream where located.

Fifth Annual Report of the Massachusetts Board of Gas and Electric Light Commissioners.

The Fifth Annual Report of the Board of Gas and Electric Light Commissioners has been presented. In the State there are 75 gas companies, 26 of which have the right to supply both gas and electricity, and 100 electric light and power companies. So far the policy of the Legislature, as shown in the various acts for the regulation and control of gas and electric companies, has been fully justified. The work of the Board in executing these laws has been done with a constant regard for the welfare of the communities in which it was called upon to act. It has had, following the policy indicated by the Legislature, great confidence in the wisdom of allowing one company to do all the lighting in smaller cities and towns. When consumers have been shown the powers of the Board to regulate the price and quality of light a general approval of the enactments and of its action has been manifested. The companies are as a whole very ready to correct any fault to which their attention is called by the Board. In executing recent statutes the Board has reluctantly been compelled to refuse new companies the privilege of going into business, but these adverse decisions were felt to be most beneficial to the permanent interests of the city or town. Seven gas companies have been authorized to engage in electric lighting business, and there have been six cases before the Board on appeal from the decisions of the Mayor and Aldermen and Selectmen of as many cities and towns. The various decisions are given at length.

In the past year the property of the Cottage City Gas Company has passed to a new company, but the business has been so interrupted that no report of value could be made. The Citizens Steam and Gas Light Company, of Lynn, gave up making gas early in the year, and its works were destroyed in the late fire. The New Bedford Company has been authorized to supply gas to Fairhaven.

The Board since its last report has continued its investigations on the subject of water gas. It is understood that the parties in interest do not desire to offer further evidence in the cases pending at the close of the year. The Board believes that some modification of the present law is desirable, and that a report of the work of the Commissioners in this branch of their duties ought to be made to the Legislature at the present time. Accordingly a very long and interesting chapter is devoted to water gas. The Board, by personal inspection and correspondence, has heard from more than a hundred companies. So many different items and circumstances enter into the manufacture of gas that it is not easy to exactly determine the relative cost of water and coal gas; but from a wide survey the Board estimates the cost of coal gas in the holder at from 50 to 57 cents per 1,000, and of water gas at from 46 to 55 cents. Various improvements in the manufacture of water gas are noted, and the advantage afforded by its apparatus in the production of gas of the high illuminating power now demanded is alluded to. The larger companies recognize these advantages, and nearly one-third of all the companies in the country now manufacture some water gas. Various benefits resulting from the manufacture of both kinds of gas in the same works are specified.

The question of the comparative safety of water and coal gas is pronounced a very perplexing one to solve satisfactorily. One or more members of the Board have examined personally the premises where deaths have occurred from asphyxiation by inhaling gas. A few of these deaths were caused by coal gas, others probably by a mixed gas, but the larger number were due to water gas. Results of the investigation are given in detail. As near as can be estimated from reports received from various sources there were 107 deaths in the United States, in 1889, from inhaling illuminating gas. There is conclusive evidence that 30 of these persons committed suicide, and there were several others where the circumstances pointed to the same fact. But this leaves 77 deaths caused by the accidental inhaling, 25 happening in places where only water gas is manufactured; 46 occurred in places where mixed gas is made; and 6 in towns using coal gas only. Forty-six of the deaths occurred in hotels, mostly of the cheaper class, lodging and boarding houses, where the rooms were small and poorly ventilated. In 18 of the accidents the gas was blown out by ignorant persons; 8 deaths were caused by gas stoves; 1 by a leaky pipe, and 3 by defective keys where the gas is turned on to the burner. Various statistics bearing on these deaths are given, and the inferences drawn are that about 30 per cent. of the deaths from illuminating gas are

suicides, 20 per cent. are persons more or less intoxicated at the time of the accidents, and a considerable number are persons unacquainted with the use of gas. A comparatively small number of cases are purely accidents that could not have been avoided.

The Board's interpretation of chapter 428 of the acts of 1888, is that it is not permitted to issue a revocable license or one subject to modification, or qualify in any way the certificate they issue "that in their opinion the gas can be used with safety" for illuminating purposes. The danger which appertains to the careless use of any gas is an obstacle in the minds of the Commissioners against granting a license in the form required by the law. The question of the comparative safety of the various kinds of gas and the considerations bearing upon their use are discussed, and suggestions advanced as to the means for securing greater safety. The Board is firmly of the opinion that the certificate as to safety ought to be omitted from the license, and that it should be empowered to place such conditions in the license as will tend to guard the community against accidents. A draft of a bill embodying these ideas is submitted.

The usual elaborate tables are included in the report. These are prepared by the efficient clerk, Mr. Walter S. Allen, and involve a great amount of labor. The average price for coal gas to consumers of 24 companies making more than 30,000,000 feet each is \$1.4495 a thousand. The average for the rest is \$1.987, an average for all of \$1.4935 a thousand. In 1886 the average price was \$1.72, in 1887 it was \$1.66, and in 1888 it was \$1.56, showing a gradual reduction each year. The number of meters in use June 30 was 100,714, representing a capacity of 742,781 lights, an increase of 5699 meters, or 41,930 lights.

The number of public gas lamps continues to diminish in about the same ratio as last year, electric lights taking their places. The coal gas companies lost 999 lights.

The total income of all the companies was \$4,869,342.11. The expenses were \$3,314,337.98, leaving the net income \$1,555,004.13.

The year was an active one for those engaged in the electric lighting business. There were 44 new electric light and power companies, and 4 new companies for the manufacture of gas and electric light incorporated. The Board says there is a demand for a simple and economical means of testing the candle power and quantity of electricity supplied to consumers.

The demand for both gas and electric light is constantly growing, and the advance in electric lighting has been especially noteworthy. The following table shows the number of electric lights of various candle power in use in the State in 1888 and 1889:

	1888.	1889.
16-candle power.....	52,075	80,075
20 " "	1,200	2,800
15 " "	880	880
2,000 " "	5,846	6,978
1,200 " "	2,757	4,206
1,600 " "	110	130
1,500 " "		35
1,800 " "		40
800 " "		140.

Annual Meeting of the Springfield (Mass.) Gas Company.

"Observer" forwards the following regarding the annual meeting of the Springfield (Mass.) Gas Company:

The annual meeting of the Springfield Gas Company was held on the 27th of January, and resulted in some radical changes in the management, the most important of these being the resignation of Mr. J. L. Hallett from all active participation in the direction of the Company's affairs. To say that this will be regretted by the Eastern fraternity is to put it mildly; and, speaking for myself solely in giving utterance to the opinion, I have every reason for believing that a certain clique in the ownership are responsible for having made it so unpleasant for Mr. Hallett that in justice to himself he could no longer retain the place and preserve his self-respect. When the situation is fit for final review I will forward a statement of the case for the judgment of your readers.

To come back to the proceedings, Messrs. J. L. Hallett and W. H. Wesson retired from the Board of Directors, and were succeeded by Edward S. Brewer and James Kirkham. The plan announced some time ago to separate the offices of Treasurer and Superintendent was carried out, and Ira B. Allen was chosen Treasurer, receiving a large majority of the 3,484 shares of stock represented. Joseph L. Hallett, who has held for two years the offices of Treasurer and Superintendent, had sent in his resignation of the latter office to the Board of Directors a week ago. The Directors tabled the resignation, and Mr. Hallett ap-

pealed yesterday to the stockholders. As they took no action to define the duties of Treasurer and Superintendent, Mr. Hallett will persist in his resignation as Superintendent. E. S. Brewer was chosen clerk of the corporation to succeed Ira B. Allen.

As stated in Mr. Hallett's report given below, the trouble in the management of the Springfield Company has been partially due to a misunderstanding between Mr. Hallett and the bookkeeper, Ira B. Allen, who has for some time been ambitious to become Treasurer. After a dispute about the conduct of each regarding the Treasurership, Mr. Hallett discharged Mr. Allen. The Directors questioned Mr. Hallett's right to take such action, and Mr. Allen was taken back at their request. This resulted in Mr. Hallett's resignation as Superintendent and Manager. Mr. Hallett has been with the Company since his return from the war 25 years ago, and has been its Manager for eight years. Below is the report he submitted as Treasurer, Manager and Superintendent of the Company:

The manufacturer feels a sense of pride when, as the time comes around for the semi-annual and annual accounting, the balances are all found on the right side. This is especially true when the business is threatened with loss from competition. There was a time when the gas lighting industry was practically a monopoly and the gas manager independent of criticism. There was no thought of seeking trade; it must come to him, and every foot of service pipe and item of labor was charged to the consumer at a large profit. Nor is it long since a tax was levied on the consumer for the use of that indispensable machine, the meter, of equal benefit to both producer and consumer in determining the amount of the gas bill. Then 3½ cubic feet of 15 candle power gas to the pound of coal was thought creditable, and a shrinkage of 20 per cent. in the annual output was of such little consequence it was not considered worth digging for; 18,000 feet to a bench of retorts was an excellent result. The gas business of 1890 is wholly unlike that of former years. Competition and would-be competitors, cheap oil with improved burners, have stimulated the gas manager to greater activity. The yield of gas from the coal has nearly doubled. Candle power is 25 per cent. better, and the unaccounted-for gas reduced to a minimum, while the price now charged the consumer is less than the product then cost. Instead of 18,000 feet to the bench 50,000 is now obtained. Improvements in the method of making and using gas have placed the gas business on a better footing. In lieu of the old-style closed globe and iron burner with its flickering light, opal, etched and ground shades, with large opening and automatic governing burners, have been substituted, producing a soft and pleasant light. The Lungren and arc high power burners (the latter made in this city) have met the demand for more light, have displaced the electric light in some cities and to a limited extent here.

The encircling of the city with electric wires, cutting out hundreds of gas lamps, means a diminution of millions of feet in the annual output. Nor is it a pleasant thing to see the names of some of our best consumers of years standing dropped from the gas ledger by the inroad of a competing light company, with the only alternative to erect an electric plant or purchase from others a franchise of doubtful profit. Considering the large growth in population and general business prosperity, the effect of competition has not yet been felt. In fact, the records show an increase of over 3,000,000 feet over the previous year. Nor would there be any loss in the annual sales, in my opinion, were the charges for electric lighting put on a paying commercial footing. This is evident from the number of electric companies throughout the country that have sunk their entire capital and sold out for a sum equivalent to their debts, have gone into insolvency, or are doing business at a loss. While we are losing some customers as the electric light system is extended, it is equally true that as the electric light becomes no longer a novelty, and as it is demonstrated that for the same money more light is obtained from gas, with more reliable service, our former patrons return to gas lighting.

During the year special efforts were made to increase the summer consumption by the use of gas stoves. This is a department of the business that admits of large development. Stoves and ranges for domestic and mechanical purposes, and gas engines for power, have reached a state of perfection that, for efficiency and economy, can without hesitation be recommended. Our policy in regard to stoves is, where possible, to sell them at cost rather than to rent, believing that an article that costs something would be more appreciated and have better care than if the property of others. To show what limited knowledge the public has of these appliances, in a canvass made last summer we found those who did not know what a gas stove was. Others were prejudiced, and thought the daily use of gas for cooking would be a ruinous expense. To overcome these objections 275 stoves were given away, and these helped the sale of

as many more. The result was, the skeptical were more than pleased, the old kerosene stoves discarded forever, and statements made by some that, to their surprise, the cost of gas was no greater than it had previously been for oil. The revenue from these gift stoves in one season paid their cost and a profit beside. Seventeen ranges, 48 heating stoves and 506 cook stoves were sent out during the year, making about 1,900 now in use. Thirty-eight per cent. of the output for the months of June, July, August and September, and 10 per cent., or 8,000,000 feet of the whole amount of gas made in the year, can be credited to gas stove account. The people have only to learn the advantages of cooking and heating by gas, and they will readily adopt it in preference to all other fuel. The State Gas Inspector reports that the illuminating power and purity of the gas is better than in any previous year.

The report for the year shows that 7,015 tons of coal have been used, an increase of 230 tons over 1888, while 46,290 gallons of crude oil have been consumed, an increase of 4,678 gallons over the previous year. There were 82,582,000 cubic feet of gas made, an increase of 3,363,000, while there were 758 meters set. There have been 13,043 feet of gas mains laid, against 10,935 the preceding year, while 159 houses have been connected with gas, 19 with steam, and 571 gas stoves and ranges have been disposed of. The city has disused 483 public lamps. The average candle power of the gas has increased to 18.58, from 18.24 in 1888, while the sulphur has been reduced from 9.88 to 9.72, and ammonia from 2.41 to 2.10.

Mr. Hallett continues as follows: I am pleased to report that the make of gas for January, 1890, will approximate the send out of January, 1889, notwithstanding the loss of the public lamps. The earnings have now reached such proportions, I believe the time has arrived when a substantial reduction of not less than 25 cents per 1,000 feet in the price of gas should be made. This is due the consumer, as the use of gas for lighting, fuel and mechanical purposes has become a public necessity. This reduction would still provide for all fixed charges, including 8 per cent. dividends amounting to \$40,000 and leave a handsome margin for the extension of the plant. In 10 years the amount of gas made has doubled. The output was 41,071,000 in 1879, while in 1889 it was 82,582,000 cubic feet. The net profits for 1889 were \$60,224. The earnings in 10 years were \$629,676, including \$32,000 earnings on the steam plant, from which were distributed \$525,500 in dividends. While generous to ourselves the public is entitled to a share of the profits in a reduction in the price of this commodity, and it is wise for you to keep in mind that the rights of the consumers are fully protected as to the matter of the price and quality of the gas, and that if a reduction is not considered, advantage of the provisions of statute authorizing application to the Gas Commissioners for a reduction in prices may be made.

In presenting this report and laying down my charge as Treasurer, not being a candidate for re-election, I wish to submit to you, stockholders, a question, the definite settlement of which will facilitate the work of whoever we may elect as Treasurer. Has the Treasurer the privilege of appointing his own clerks and bookkeeper, the privilege to appoint carrying with it the right of removal? This question has already been raised in your Board of Directors and with what seemed to me a singular unanimity of opinion, they agree that the Treasurer has no such privilege or right. A brief statement of a few facts may serve to set forth the question clearly. On January 10, for what seemed to me imperative reasons, I discharged Ira B. Allen, who had been for many years in our service. The Directors claimed that in such discharge I had exceeded my authority and they requested that he be reinstated. I presented to them a written account of Mr. Allen's conduct, and set forth what I considered the privilege of the Treasurer to choose his own subordinates. Their opinion, however, remained unshaken. In the course of a few days Mr. Allen, in company with one of the Directors, called on me and offered full apology for his conduct, and out of consideration for him, as a personal matter, I received him back in his old place. I took him back not because I thought that in his discharge I had exceeded any authority vested in me as Treasurer, nor because in his discharge I had acted unjustly, for his apology showed the propriety and rightfulness of my action, but I reinstated him because he had been a faithful servant of the Company for many years, and after this unfortunate experience I thought that neither I nor the Company would have any reason to complain of his future.

The really important question (for Mr. Allen happens only to be the cause that brings it to the surface), as to whether the Treasurer has the right to appoint his own clerks, is left wholly undetermined. I quote from my statement to the Directors:

During 25 years, to my certain knowledge, the Directors, as a Board, have never been solicited or counseled in regard to the appointment of any employe of the Company; with the exception of a Superintendent,

and in the case of Elis A. Hallett. To this the records attest. The only by-law bearing on appointments is article 5 which reads, "A President shall be chosen by the Directors who shall preside," etc., "all other officers or agents shall be appointed by the Directors, who shall prescribe their duties and fix their compensation," also, "the Directors shall elect a clerk who shall keep a record of the Board." The word "agents" as here used does not apply to mere clerks and employes; otherwise all laborers at the works could only be employed and discharged by the Directors. The fact that the Treasurer is responsible for all of the moneys received, keeps the accounts and is the party in charge of the finances of the Company, is required to give bonds for the faithful performance of the duties of his office, carries with it, by implication, the right to choose the bookkeepers and clerks who are to handle the money for which he and his bondsmen are liable, and make entries on the books for the accuracy of which he is responsible.

For the best interests of the Company and for the convenience of the Treasurer who may be elected and for our common interests as stockholders this question ought to be decided.

ITEMS OF INTEREST FROM VARIOUS LOCALITIES.

In our issue for the 13th ult. it was stated that the trouble between the Lockport (N. Y.) Gas Light Company and its employees had been satisfactorily arranged. There are more Lockports than the one in this country, and unfortunately imperfect proof reading caused our item to be credited to the wrong place. As it would not do any particular good now to name the Lockport where the labor trouble did crop out, we will not so identify it. We can, however, in justice to the Lockport (N. Y.) Company, say that its principal employees are the same who have figured on its pay rolls for terms ranging from 15 to 30 years. Oh, no; it was not Lockport, N. Y.

In a letter recently received from an esteemed correspondent, the following tribute to the late Theobald Forstall is paid: "Mr. Forstall was a self-made man; he was fearless and honest. In all the years I have known him I never knew him to do anything to be ashamed of. Not a time server, he knew his duty and performed it. He made many friends and very few foes. Though others might differ with him, yet they recognized his simple sincerity, and were bound to admire him for it. A busy man, yet he always had time to extend to others the courtesies of a gentleman. He imparted information to others very freely, and the student and uninitiated in gas works were never turned away unanswered when seeking information. I feel that a great man has fallen; quiet and unostentatious, he wielded an influence such as few men have. He was prompt, thorough and painstaking—a man of clear foresight and prompt judgment. He was a thorough believer in low prices for gas—\$1 was his mark. He had been ailing for some time, and his trip to Europe last summer did not benefit him. On his return he grew rapidly worse, and we all said that death had marked him for his own. He did not like to have any reference made in his presence to his health. He declined to go south or elsewhere for his physical benefit, preferring to be with his family, to whom he was much attached. He was a kind husband and father, and a true friend. We all miss him greatly. I think the worry and cares of business had something to do with his early breaking down. It gives me great satisfaction to say that his son Alfred, who is in charge of the works of the Chicago Gas Light and Coke Company, is a most estimable young man, well qualified to keep the name of Forstall before the fraternity. I attended the funeral services, which were very simple; the ceremonies were carried out in accordance with the wishes of deceased. He desired that no one mourn for him.—J. S."

SOMETHING over a fortnight ago an explosion occurred in the purifying room of the Ottawa (Ont.) gas works, that caused damage to the amount of \$500.

A MEETING of representative citizens of the borough of Downingtown, Pa., was held a few days ago, the purpose for which the gathering was called being to agitate the availability and good policy of purchasing from the present owners the coal gas and water supply plants, the same to be thereafter operated on borough account. The sentiment of the gathering was strongly inclined to the affirmative of the proposition, and a committee of 5 (Messrs. Jos. H. Johnson, John McGraw, H. B. Sides, S. A. Bicking and D. M. Cox) was appointed to interview Mr. Frank Buck, President of the Company, as to what the proprietors would consider a fair price for the property. The President, who spoke for perhaps 85 per cent. of the stock, replied that the entire capital of the Company (meaning both gas and water divisions of the enterprise)

could be purchased for \$75,000, and that that offer would remain open for 30 days. The citizens, on receiving the report of the committee, enlarged the latter to 15 members, with instructions to have the law examined, to determine whether or not it was in the province of the borough to raise money for such a purpose. The water works franchise of the Company is a valuable one, and the gas works portion of the enterprise would no doubt have been fairly profitable had even ordinary routine business management been devoted to its development.

At the annual meeting of the Peoples Gas Light Company (Manchester, N. H.) the following officers were elected: President, John B. Varick; Vice President, Frank Dowst; Treasurer, W. L. Elkins, Jr.; Supt., Walter G. Africa; Directors, W. L. Elkins, Jas. F. Briggs, John B. Varick, Frank Dowst, Alonzo Elliott, Jas. A. Weston and W. L. Elkins, Jr.

THE Aurora (Ills.) Gas Company has been greatly enlarged and improved the past season. Over 7 miles of mains were put down, and plans for an extension similar to that of 1889 are being prepared for 1890. Mr. Copley says that the Company proposes to keep its pipe lines ahead of the times instead of behind them. This probably means that the mains are to be extended to what is known as the Downer Place Addition. The moneys expended on betterments in 1889 must certainly foot up \$40,000.

THE Newport (R. I.) Gas Light Company will soon be in readiness to start up its auxiliary water gas plant. And this reminds us that if the annual meeting of the shareholders had to be postponed because of *la grippe*, the latter demon seems to have been unable to "hold down" the engineering and executive management. In any event, the reports of work accomplished for the last six months of 1889 show that over 4 per cent. had been earned on the capital stock, which rate of dividend was declared when the annual meeting was finally brought off.

THE Westinghouse Machine Company, of Pittsburgh, has received an order through its agency at Copenhagen, Denmark, for one of its famous automatic compound engines. The size selected is 14 and 24 by 14, and it will be set up at Kopparberg's Bergslaget, at Falur, near Stockholm, Sweden. Large numbers of these engines are now being shipped to foreign countries.

At the annual meeting of the Belfast (Me.) Gas Company the following officers were elected: President, W. B. Swan; Clerk and Treasurer, John H. Quimby; Supt., A. K. Pierce; Directors, W. B. Swan, N. F. Houston, A. A. Howes, Chas. R. Hazeltine and John H. Quimby.

THE Fremont (O.) Electric Light and Power Company and the Fremont Gas, Steam and Plumbing Company have been consolidated. Mr. W. H. Ford has been chosen Secretary of the consolidated enterprise. Important plant improvements—both on the gas and electric light divisions—will be carried out forthwith. Mr. Fred. Fabing, former Superintendent of the gas works, will carry on the plumbing business in Fremont. We wish him the best of good fortune in this venture.

At the annual meeting of the East Boston (Mass.) Gas Company the following Directors were chosen: Stephen H. Whidden, Thomas J. Whidden, William R. Sturtevant, John Thompson and Geo. L. Thorn-dike. The resignation of the Company's former Treasurer, Mr. Frederick Pease, was received and accepted.

THE Altoona (Pa.) Gas Company has made a demand on the authorities for damages in the sum of \$177.80, for injuries occasioned the gas mains because of the falling in of the walls of the sewer drain now being laid through Ninth street, between Eighth and Eleventh avenues.

WE are in receipt of a couple of blotter calendars from the Kerr Murray Company, which we presume is the first issue of a series that shall be continued for the year. The calendar is for the current 30 days. It is a good idea.

WE are also in receipt of a very handsome annual calendar, published at the instance of Nathaniel Tufts, of Boston, Mass. It is a beautiful specimen of the engraver's art and the printer's skill. The etching on supporting sheet shows a typical mid-winter scene in New England—that is, it would be typical of the scene that should exist now, but which does not. The etching, however, has yet two chances of becoming emblematic of the winter season—the current month and December next.

THE Philadelphia *Inquirer*, of January 24th, said: "Financial circles found a choice morsel of gossip yesterday in the rumor that there had been consummated the sale of a controlling interest in the United

Gas Improvement Company to a syndicate of English capitalists. To understand what such a sale means to the money market, it is necessary to know that the capital stock of the Company is \$5,000,000, and that its gas plant possessions throughout the United States are almost of inestimable value. Practically it is a trust that seeks control of the gas interests of the country. The plants of city after city have been purchased, and many important patents in the gas manufacturing industry are owned by it. Based upon the knowledge that negotiations were pending for the purchase outright, or of a controlling interest in the Company, unknown investors have been buying all the stock of the Company coming out on the market. Within the past few days there has been a large increase in the market quotations of the stock. Its par value is \$50, and yesterday 100 shares were eagerly bought in at 80, and 14 shares at 81 just as readily found a purchaser. This is against its closing price of 72½ in the early part of the month. The terms of the rumored syndicate purchase are shrouded in mystery; in fact, every effort is being made by those in interest to keep the matter strictly secret, but the shrewdest financiers give greatest credence to the most conservative statement of the hour, which is that \$100 per share was offered for a controlling interest in the stock. A prominent officer and large stockholder of the Company, who asked that he be quoted anonymously, said last night: "I will not deny that there have been negotiations with a number of English gentlemen who propose forming a syndicate and putting their capital in our Company, but nothing definite has been arrived at yet. I am not at liberty either to state the names of those who will compose the syndicate or of the terms of the negotiations. Everything in life is so uncertain that it is hard to say when any proposition will be consummated. I can say, though, that none of the negotiations so far considered contemplate a change in the methods of the Company or of officers. The way I account for the sudden rise in the stock is that its intrinsic value has met greater appreciation in the eyes of financiers. Not at any time during the past year, though I am a large holder, would I have accepted \$100 per share for my stock. For a long time we have been looking for capital. We could use it advantageously; but I think the terms for a controlling interest would have to be more seductive than any sensible financier would offer. There is no desire to sell such an interest; we consider the works too valuable for that. I do not think the recent increase in stock at all artificial."

WE gather, from an independent source, and one quite likely to know something of what is going on in the above respect, that the Company has been successful in securing a long loan (at low interest rates) of considerable magnitude, the money to be used in increasing the number of leaseholds, or actual purchase of plants, to be operated by the Company.

MR. ROBERT F. MULLINS, lessee of the Fishkill and Matteawan (N. Y.) Gas Company, is endeavoring to secure a contract for the public lighting by gas of these villages. As an inducement he offers to supply gas to the lamps at a concession of 25 cents per thousand cubic feet from that now charged as the lowest net rate to ordinary consumers.

MR. MULLINS' proposition recalls to mind the fact that Superintendent W. H. Hayden has made many changes at Fishkill in the plant conditions respecting the gas supply. Hayden does not believe in manufacturing gas simply for the purpose of permitting an abnormally large percentage of the product to wander at its ill smelling will through the soil that covers the mains.(?)

At the annual meeting of the Charlestown (Mass.) Gas Company the officers chosen were: President, J. F. Hunnewell; Clerk and Treasurer, G. B. Neal; Directors, J. F. Hunnewell, W. W. Wheildon, P. J. Stone, J. A. Sawtell, L. B. Hathan, C. F. F. Byam and C. R. Lawrence.

WE understand that an explosion that occurred on the works of the Sioux City (Ia.) Gas Light Company, on the night of Jan. 21, destroyed apparatus valued at \$10,000.

THE electric light plant at Cleburne (Texas) has passed out of the receivers' hands, the property and franchises having been purchased by Max Elser, of Fort Worth and W. H. Gaston, of Dallas.

At the annual meeting of the Warsaw (N. Y.) Gas Company the officers chosen were: President, S. D. Lewis; Vice-President, Augustus Frank; Secretary, J. B. Gates; Treasurer, B. F. Fargo; Directors, T. G. Hulett and L. W. Pettibone, of Niagara Falls, and S. D. Lewis, Augustus Frank, L. W. Thayer, Wm. Bristol, E. E. Forman, L. H. Humphrey and J. B. Gates, of Warsaw.

THE following leaves from the history of the Providence (R. I.) Gas Company will be read with interest :

Year.	Annual Output, Cu. Ft.	Year.	Annual Output, Cu. Ft.
*1849.....	6,178,000	1860.....	58,143,000
1865.....	75,626,000	1870.....	132,310,000
1875.....	258,039,000	1880.....	280,833,400
1881.....	305,780,600	1882.....	310,026,500
1883.....	329,622,000	1884.....	344,773,000
1885.....	354,000,000	1886.....	361,149,000
1887.....	383,096,000	1888.....	429,720,000
1889.....	450,000,000		

The Company has a main mileage of 161, and 12,700 meters are in position. The unaccounted-for gas is returned for '89 at 8.7 per cent. The Company is notable in Providence financial history from the great number of shareholders, a statement of which is here given to prove the faith of the residents in the stability of the enterprise: There are in all 938 shareholders, among which the 50,000 shares are distributed. Of these 323 are men, holding 19,236 shares, 453 are women, holding 17,283 shares, 73 are trustees, holding 690 shares, 13 are guardians, holding 215 shares for their wards, and 41 are administrators and executors, holding 220 shares. Besides these 30 institutions have 4,124 shares. Three stockholders have 1,000 shares or over, 9 have from 500 to 1,000 shares, 123 have from 100 to 500 shares, 110 have from 50 to 100 shares, and 693 have less than 50 shares. There are 46,188 shares held by 833 shareholders in Rhode Island, and 3,812 shares are held by persons outside of the State. These latter can be traced to Massachusetts, New York, Connecticut, Maine, New Jersey, Vermont, California, Illinois, Ohio, New Hampshire, Pennsylvania and Virginia.

MR. A. B. RICHARDSON, of the Dover (Del.) Gas Company, writing under date of Jan. 22, on the subject of the Toraya process of gas making which is soon to be tried on a fairly large working scale at one of the branches of the Philadelphia municipal gas works, says: "The new Toraya process of making gas appears to be very similar to a process used here in Dover in 1862. The gas works in this town were built just before the war to manufacture gas from rosin, and during the war rosin went up to \$60 per barrel. Then the following process was resorted to: Yellow pine wood was cut up into small blocks and soaked in oil until the wood was completely saturated. The blocks were then put into a charger, and the charger put into the retorts (of which there were six) and kept until all the gas was taken from the wood, which left the blocks transformed into very nice charcoal. The gas was then passed from the retorts to a scrubber filled with shavings, thence to a purifier filled with lime, thence to gasholder and street mains. As to the quality of the gas. If the blocks had taken up just the right quantity of oil the gas would be good; if not enough oil had been absorbed it would be poor; if too much oil it would smoke. In fact the ceilings in all the houses that burned the gas were well smoked, and, furthermore, the oil condensed in the pipes and fixtures, so that when the key was opened to light the gas the oil would come out in a spray before the gas would ignite. If the key was opened to light a burner that had not been used for 10 days, the gas would be so poor that it would not light until the freshly-made gas came to the burner. The consumers finally became so disgusted that they quit using the gas, consequently the works were shut down for a year. Then the firm of Richardson & Robbins bought the works and eventually fitted them up for making coal gas. The meters were worthless, the pyroigneous acid having destroyed all the diaphragms. Perhaps the Toraya Gas Company has overcome the difficulties."

AT the annual meeting of the Davenport (Ia.) Gas Company the following result was reached: President, J. J. Richardson; Secretary and Treasurer, Ross Woodmansee; Directors, G. H. Pendleton, O. T. Gaylord, R. Woodmansee, W. C. Putnam and J. J. Richardson.

MR. J. H. FARISH, Secretary and Treasurer of the St. Joseph (Mo.) Gas and Manufacturing Company writes: "It might interest the gas fraternity to know that our fuel gas schemers are not all dead. A few days ago Mr. W. S. Crosby, of Chicago, the chief promoter of the enterprise, despairing of the resurrection of his first bill, prepared another—a twin brother of its predecessor, except that it called for a deposit of \$15,000, to be made by him, and to be held by the City Comptroller, until the sum of \$50,000 should have been expended by him, the said Crosby, in the erection of a fuel gas plant, when the deposit should be returned to him. At the same meeting of the City Council another water gas bill was introduced by one Charles McGuire, an obscure resi-

dent of this city, and undoubtedly a 'man of straw.' In his bill, Mr. McGuire, as a bait to our Councilmen, proposes to furnish what *light* and *heat* the city may wish in all of its public buildings, for *nothing*. It seems hard for a legitimate enterprise to live when so many people are willing to do business for nothing. However, both ordinances have been referred to a special committee of five, by whom the matter will soon be investigated."

THE authorities of St. Joseph would seem to be easily gulled were they to swallow the bait offered by either Crosby or McGuire; for certainly neither proposition contains anything likely to be of material benefit to the city. Should Crosby be successful he gets his \$15,000 back. Quite likely he would expect to receive interest on it—and as for McGuire—well! when his employers had been successful in blackmailing the present St. Joseph Company, the latter could of course elect to work under its old charter. In the event of the McGuire coterie being obliged to buy out the old company, they would undoubtedly elect to work under the old company charter, wherefore the city would not be a gainer in either event. The rulers of St. Joseph might better encourage and protect the old company, whose course towards the public has always been of the liberal order.

IN proof of this latter claim we beg to submit the following evidence, which comes to us in the shape of an official announcement from Secretary Farish. The concession took effect on the first inst., and its terms, as explained by Mr. Farish are: "Conforming to our usual custom of reducing the price of gas from time to time as our increasing consumption would justify, we have reduced the price of gas to \$1.50 per 1,000 cubic feet to all customers using from 1,000 to 100,000 cubic feet monthly. Quantities in excess of this are to be supplied at \$1.37½, and gas used for fuel or power purposes is to be sold at \$1.25."

WE think our readers will agree with us that these are cheap rates. Further, the article of gas that the St. Joseph Company distributes—when used for fuel purposes—at the rate of \$1.25 per 1,000 will be found at least twice as effective as the article which Crosby *proposes* to distribute at a slightly lower rate. We would also like to add in conclusion, that the Company's ability to supply gas at these rates is a striking testimonial to the ability of its engineer—Mr. K. M. Mitchell.

A LINE from Mr. John Lorenz, Supt. of the Johnstown and Gloversville (N. Y.) Gas Company, informs us that oil of a good quality has been struck in a well that was being drilled for gas about one mile south of Johnstown. Naturally, great excitement prevails in the district over the discovery; but as yet nothing definite has been learned as to the yield, work on the well-hole having been temporarily suspended.

MR. H. A. NORTON, No. 4 Central street, Boston, Mass., succeeds Messrs. Sprague & Sons as agents for the fireclay goods from the works of James Gardner, Jr., Lockport Station, Pa. The Messrs. Sprague resigned the agency because of the pressure of other business. We congratulate Mr. Gardner on his good fortune in securing so capable a successor to the Messrs. Sprague—who are, as they ought to be, in high favor with the Eastern fraternity—since Mr. Norton is the worthy son of his father—Nashua's Honorable gas man.

AT the annual meeting of the Wallingford (Conn.) Gas Company the following officers were elected: President and Treasurer, Col. W. G. Leavenworth; Secretary, Judge L. M. Hubbard; Directors, L. M. Hubbard, W. S. Leavenworth, G. W. Hull, B. A. Treat and Mrs. W. C. McClellan.

AT the annual meeting of the Van Wert (Ohio) Gas Light Company the following officers were elected: President, A. C. Glenn; Vice-President, D. Shepard; Secretary and Superintendent, J. M. Tryon; Treasurer, G. C. Glenn. It was decided to increase the capital stock to \$37,500 from \$25,000. The business of the Company is increasing steadily, and the outlook for the year is of the most encouraging sort.

THE meter manufacturing firm of Bell & Jones will erect the new 14 ft. by 14 ft. station meter for the Philadelphia municipal gas works station at Point Breeze. The contract was awarded on Jan. 28th.

"SOME of the residents of Chelsea, Mass., are preparing a petition for the consideration of the State Board of Gas and Electric Light Commissioners in which it is sought to secure a cheaper gas rate for the city. There is evidently some malice behind this movement that can probably be traced to those not widely separated from others connected with the project for establishing a fuel gas plant in Chelsea.—HADDAM."

At the annual meeting of the Newport (R. I.) Gas Light Company, Mr. Henry Bull was re-elected President, Mr. Thomas A. Lawton was chosen Treasurer, and Mr. Andrew K. Quinn was named as Secretary. The Directors are Messrs. Henry Bull, Jas. C. Swan, Thos. A. Lawton, Philip Rider, Robt. S. Case, W. H. Fludder and A. K. Quinn. The latter takes the place of the late Mr. John A. C. Stacy.

The Cambridge (Mass.) Gas Light Company has reduced its net selling rate to \$1.60 per 1,000 cubic feet.

NEW YORK and Rochester capitalists hold an option to purchase the Batavia (N. Y.) gas works, the option to last until February 20th. It is likely that a sale will result.

ACCORDING to the minutes of a recent session of the Committee on Lamps of the Boston Board of Aldermen, several residents on Commonwealth avenue have petitioned for the restoration of gas lamps on that avenue. Messrs. C. P. Curtis, C. Woodburn and E. I. Brown appeared before the Committee and asserted that the electric lights were of but little use, particularly in the summer time, as the shade trees in the park prevented the light from extending to the sidewalks. They *wanted the gas lights restored*, but did not want the electric lights to be removed. The petition was taken under advisement.

At the annual meeting of the Manchester (N. H.) Gas Light Company the following officers were chosen: President, Hon. Moody Currier; Clerk, Lucien B. Clough; Treasurer, Walter M. Parker; Directors, Hons. Moody Currier, Nathan Parker, Daniel Clark, G. Byron Chandler and Mr. Chas. Warren.

PETER J. KLINGES has brought suit in the Philadelphia Court of Common Pleas (No. 3) on behalf of Henry Sauer, who asks for \$5,000 damages for injuries occasioned by an explosion of gas on December 28, 1889. Complainant had for five years been a tenant of the premises 2313 East Thompson street, where he carried on the business of a baker. He claims that owing to the wearing out, by oxidation, of the service pipes from the gas main, gas escaped and accumulated in the vault under the house in such volume that an explosion occurred. Sauer was severely burned, and he further asserts that his business was ruined because his house was so badly damaged that he was compelled to remove.

PATRICK HOYT, a well-known character in the employ of the Citizens Gas Light Company, of Newark, N. J., died about a fortnight ago. He was known among his fellows as "the gas house poet."

THE annual meeting of the stockholders of the Brookline (Mass.) Gas Light Company was held at the office of the Company in Brookline, on Wednesday, January 22, President Robert Amory in the chair. The report of the Clerk and Treasurer, Francis W. Lawrence, was a very satisfactory one. President Amory, in presenting the Directors' report, stated that the loss by leakage had been reduced to 10.95 per cent., although the number of consumers per mile of main has not correspondingly increased. The taxes are a little more than the salaries of the Company's executive officers. The profits of the Company from electric street lights were barely 4 per cent. last year on the cost of installation. There is every reason to believe that the cost of a municipal plant to the taxpayers would be very much larger than it is to a private corporation of a Gas and Electric Light Company combined under one management, and with this understanding of the case, the Directors had agreed to furnish electric lights for Brighton at 40 cents per night for 5 years. This will yield small profit, but will obviate the necessity of enlarging the Company's gas plant, the demands upon which are now almost up to the limit. President Amory reported the sale of the stock of the Suburban Light and Power Company to a Roxbury syndicate. The following named Directors were chosen by a vote of 3,354 shares each, the entire number thrown: Robert Amory, Wm. H. Hill, Francis W. Lawrence (Clerk and Treasurer), F. H. Odiorne, McPherson Lemoyne. Organization was effected with the unanimous choice of Mr. Amory as President.

Recent Patent Issues.

The following list of recent patents relating to the gas interests is specially reported by Franklin H. Hough, solicitor of American and foreign patents, 925 F street, N. W., Washington, D. C.

ISSUE OF JANUARY 7, 1890.

- 419,098. Gas, Apparatus for Making Oil. T. and S. Alexander and R. Patterson, Kirkintilloch, Scotland.
418,807. Gas Blow Pipe. D. M. Monroe, Baltimore, Md.
418,846. Gas Burner for Stoves. J. H. Keyser, New York, N. Y.
418,821. Gas Engine. J. D. Smith, Philadelphia, Pa.
418,711. Gas, Manufacture of. W. Rogers, Pittsburg, Pa.

ISSUE OF JANUARY 14, 1890.

- 419,183. Gas Burner. G. K. Cooke, Jamaica, N. Y.
419,444. Gas Fuel Burner. C. L. Holden, Indianapolis, Ind.
419,350. Gas Washing Apparatus. M. A. Piedra, Schriever, La.

ISSUE OF JANUARY 21, 1890.

- 419,845. Gas and Liquid Holder. J. Flannery, New York, N. Y.
419,651. Gas Burner. W. F. Folmer, New York, N. Y.
419,652. Gas Burner. W. F. Folmer, New York, N. Y.
419,784. Gas Burner. W. S. Mead, New York, N. Y.
419,806. Gas Engine. C. W. Weiss, Brooklyn, N. Y.

ISSUE OF JANUARY 28, 1890.

- 420,193. Gas and Liquid Holder. J. Flannery, New York, N. Y.
420,169. Gas Engines, Gas Regulator and Equalizer for. W. C. Rossney, Cambridge, Mass.
420,241. Gas Motor or Engine. P. J. McMahon.
420,412. Gas Regulator. J. H. Lehman, Philadelphia, Pa.

Correspondence

[The JOURNAL is not responsible for the opinions expressed by correspondents.]

The Lighting Situation at Fort Scott, Kas.

FORT SCOTT CITY GAS COMPANY,
FORT SCOTT, Kas., January 27th, 1890. }

To the Editor AMERICAN GAS LIGHT JOURNAL:

A word about the present condition of the lighting interests in Fort Scott, Kas.

Having seen nothing in the JOURNAL in regard to the present *raid* upon the lighting industries of the city, I think it may interest the JOURNAL readers, and the gas fraternity generally, to learn what is going on in this portion of Kansas. The total failure to develop and distribute natural gas at this place three years ago left the parties badly stranded, and several later attempts to form combinations by which the old natural gas pipe lines were to be made use of for an opposition illuminating company all resulted in failure, until last summer, when, in the throes and agony of despair, the parties visited New York and picked up one W. H. Frost, at the time in the employ of the "Consolidated Gas Company," and induced him to put his money, or that of others, into a scheme with the idea of wiping out, at one fell stroke, all of the legitimately invested gas and electric light interests in this city.

A reorganization of the old Company was effected by electing Mr. Frost President and General Manager, and Messrs. Geo. G. Porter and C. W. Isbell, of the Smith & Sayre Mfg. Company, New York, named in the Directory, together with others here, who had been hurt in the failure of the natural gas scheme.

Work was commenced on an expensive "coal gas plant," and *flaming advertisements* inserted in the daily papers that gas would be furnished for both *heating* and *lighting* purposes at 50 cents per 1,000 cubic feet, and that it would be as cheap as coal *for fuel*.

Gas was to be furnished by the 1st of January, 1890, and the city was thoroughly canvassed for consumers. Service pipes and meter connections were to be put in free of charge, and people were led to believe that they were to have this gas for fuel as cheap or cheaper than coal. Their building is still incomplete, but work is progressing on it, and I presume that in a few months they will be ready for business.

It is possible that Eastern capital may find it very profitable to invest in opposition gas companies in Kansas for the purpose of selling gas at 50 cents per 1,000 cubic feet, but the average gas manager will be pleased to learn by what method it can be accomplished. If it has ever been demonstrated in the East that such a thing can be done, why does not New York keep her *educated experts* at home, building gas works and selling cheap gas? This question we would be pleased to see answered.

The Fort Scott City Gas Company, that has supplied the town with gas for over 20 years, extending its works from time to time to meet the wants of the people, laid out in 1887 and 1888 \$30,000 for improvements and extensions, and owns as complete a manufacturing and distributing system as can be found in any city of the size of Fort Scott, either East or West. To sum up, it has a capacity of over 200,000 feet per day, and nearly 15 miles of substantial cast iron mains, the price for gas ranging from \$1.25 to \$2 per 1,000.

The electric light plant established over 4 years ago with a capital invested said to be nearly \$100,000, is furnishing incandescence lights at from 25 to 75 cents each per month, against which the old Gas Company has thus far held its own.

The fact of two Gas Companies and one arc and incandescence electric light plant engaged in a triangular fight, in a city of the size of Fort Scott, does not look promising for large dividends in the near future. The old Companies, backed by home capital, will maintain their position at all hazard, and somebody will suffer.

L. K. SCOFIELD, President Ft. Scott City Gas Co.



A. M. CALLENDER & CO.,
PROPRIETORS.

EDITOR—Jos. R. Thomas, C.E.
ASST. EDITOR—T. J. Cunningham.
MANAGER—C. E. Sanderson.

PUBLISHED ON EACH MONDAY OF THE YEAR AT
No. 42 Pine Street, New York.

TERMS:

SUBSCRIPTION—Three Dollars per annum, in advance. Single copies, 10 cents.

AGENTS.

NEW YORK.—AMERICAN NEWS CO., 39 and 41 Chambers Street.
PHILADELPHIA.—PRATT & CO., Corner Ninth and Arch Streets.
Germany.—B. WESTERMANN & CO., of New York.

MONDAY, FEBRUARY 3, 1890.

The Market for Gas Securities.

Consolidated sold up to 97 $\frac{1}{2}$ during the week, but rather free offerings towards the close drove the sale back to 96 $\frac{1}{2}$, at which figure opening sales were made to-day (Friday, January 31). On Wednesday Muller sold at auction 33 shares Consolidated at 97 $\frac{3}{8}$. Equitable is steady at 119 to 122, and Mutual is at 107 $\frac{1}{2}$ bid. Brooklyn shares are inclined to higher prices, old Brooklyn being quoted at 108 to 110, while there is every likelihood that it will soon score a still further advance. Metropolitan is at 93 to 96, and Peoples is bid for at 77. In out of town shares we note that Cincinnati gas is at 201 $\frac{1}{2}$ bid. Baltimore Consolidated lost some of the recent advance, having sold during the week at 52 $\frac{3}{4}$. There is no good reason, however, for the slump. A block of 841 shares Jersey City gas was disposed of at auction this week, at 186. It seems to us the stock is cheap at that figure.

Rumor is very busy with the intentions of those in control of the United Gas Improvement Company, shares in which are advancing rapidly. The Company proposes, as we understand it, to largely increase its operations, and in furtherance of this proposition we believe it has been determined to increase the capital stock from five to ten millions of dollars.

Bay State gas is at 23 to 25, and Laclede Common is offered at 17. Chicago Trust shares are quoted at 47 $\frac{3}{8}$ bid. The reports submitted by 21 Eastern Companies at the annual meetings of the shareholders show net average earnings on the capital stocks represented of 9.4 per cent.

Gas Stocks.

Quotations by Geo. W. Close, Broker and Dealer in Gas Stocks,

16 WALL ST., NEW YORK CITY.

FEBRUARY 3.

All communications will receive particular attention.

The following quotations are based on the par value of \$100 per share.

	Capital.	Par.	Bid	Asked
Consolidated.....	\$35,430,000	100	96 $\frac{1}{2}$	--
Central.....	500,000	50	--	--
“ Scrip.....	220,000	--	--	--
Equitable.....	4,000,000	100	119	122
“ Bonds.....	1,000,000	--	113	115

Harlem, Bonds.....	170,000	--	--	--
Metropolitan, Bonds....	658,000	--	116	118
Mutual.....	3,500,000	100	107 $\frac{1}{2}$	--
“ Bonds.....	1,500,000	--	100	102
Municipal, Bonds.....	750,000	--	--	--
Northern.....	50	--	--
“ Bonds.....	150,000	--	--	100
Standard Gas Co.—				
Common Stock.....	5,000,000	100	--	--
Preferred.....	5,000,000	100	--	--
Yonkers.....	50	112	--
Richmond Co., S. I.	346,000	50	60	70
“ Bonds.....	20,000	--	--	--
Gas Co's of Brooklyn.				
Brooklyn.....	2,000,000	25	108	110
Citizens.....	1,200,000	20	63	70
“ S. F. Bonds.. .	320,000	1000	100	103
Fulton Municipal.....	3,000,000	100	122	125
“ Bonds....	300,000	100	115
Peoples.....	1,000,000	10	77	--
“ Bonds (5's).....	368,000	--	100	--
“ “ (6's).....	94,000	--	100	--
Metropolitan.....	1,000,000	100	93	96
Nassau.....	1,000,000	25	112	--
“ Cts.....	700,000	1000	100	--
Williamsburgh.....	1,000,000	50	118	122
“ Bonds... ..	1,000,000	--	108	112
Out of Town Gas Companies.				
Boston United Gas Co.—				
1st Series S. F. Trust	7,000,000	1000	--	92 $\frac{1}{2}$
2d “ “ “	3,000,000	1000	71	72
Bay State Gas Co.—				
Stock.....	5,000,000	50	23	25
Income Bonds.....	2,000,000	1000	--	--
Buffalo Mutual, N. Y... ..	750,000	100	90	95
“ Bonds... ..	200,000	1000	95	100
Citizens, Newark.....	1,000,000	50	155	160
“ “ Bonds.	45,000	--	--	--
Chicago Gas Trust.....	25,000,000	100	47 $\frac{3}{8}$	--
Chicago Gas Light & Coke Co.—				
G'd Gold Bonds	7,650,000	1000	93 $\frac{1}{2}$	93 $\frac{3}{4}$
Equitable Gas & Fuel Co., Chicago, Bonds	2,000,000	1000	97	--
People's Gas and Coke Co., Chicago—				
1st Mortgage.....	2,100,000	1000	--	99
2d “	2,500,000	1000	--	97
Consumers Gas Light Co., Jersey City.....	2,000,000	100	--	--
Bonds.....	600,000	1000	--	--
Cincinnati G. & C. Co..	6,000,000	100	201	203
Consumers Toronto....	1,000,000	50	190	200
Central, S. F., Cal.....	80	90
Capital, Sacramento, Cal	58
Consolidated, Balt.....	11,000,000	100	52 $\frac{1}{2}$	53
“ Bonds.....	6,400,000	107	107 $\frac{1}{2}$
Hartford, Conn.....	750,000	25	102	108
Jersey City.....	750,000	20	186	190
Laclede Gas Light Co., St. Louis, Mo.—				
Common Stock....	7,500,000	100	--	17
Preferred “	2,500,000	100	--	--
Bonds.....	9,034,400	1000	86	--
Louisville, Ky.....	2,570,000	50	125	130
Little Falls, N. Y.....	50,000	100	--	100
“ Bonds	25,000	--	100	103
Montreal, Canada.....	2,000,000	100	200	208
Memphis (Tenn.) Gas... ..	750,000	100	48	51
“ Bonds.	240,000	100	103	--
New Haven, Conn.....	25	200	--
Oakland, Cal.....	35	35 $\frac{1}{2}$
Peoples, Jersey City...	--	60	61
“ “ Bonds..	--	--	--
Paterson, N. J.....	25	99	102
Rochester, N. Y.....	50	99	100
Syracuse, N. Y.....	500,000	25	--	--
San Francisco Gas Co.	60	60 $\frac{1}{2}$
San Francisco, Cal.	10,000,000	100	59 $\frac{3}{4}$	60
Washington, D. C.....	2,000,000	20	200	208
Wilmington, Del.....	50	88	90

Advertisers Index.

GAS ENGINEERS.

	Page
Jos. R. Thomas, New York City	160
Wm. Henry White, New York City.....	148
Wm. Mooney, New York City.....	160
William Gardner, Pittsburgh, Pa.....	160
Fred. Bredel, N. Y. City.....	159

GAS AND WATER PIPES.

Gloucester Iron Works, Phila., Pa.....	160
Mellert Foundry and Machine Co., Reading, Pa. (John Fox, Selling Agent, N. Y.).....	160
Ohio Pipe Co., Columbus, Ohio.....	160
M. J. Drummond, New York City.....	160
R. D. Wood & Co., Phila., Pa.....	162
Warren Foundry & Machine Co., New York City.....	160
Donaldson Iron Co., Emaus, Pa.....	160
Dennis Long & Company, Louisville, Ky.....	160

GAS WORKS APPARATUS AND CONSTRUCTION.

James R. Floyd & Sons, New York City	163
Continental Iron Works, Greenpoint, L. I.	163
Deily & Fowler, Phila., Pa.....	163
Kerr Murray Mfg. Co., Fort Wayne, Ind.....	151
Stacey Mfg. Co., Cincinnati, Ohio.....	163
Bartlett, Hayward & Co., Baltimore, Md.....	161
Morris, Tasker & Co., Limited, Phila., Pa.....	161
Davis & Farnum Mfg. Co., Waltham, Mass.....	151
R. D. Wood & Co., Phila., Pa.....	162
Bouton Foundry Co., Chicago, Ills.....	163
Smith & Sayre Manufacturing Co., New York City.....	163
Fred. Bredel, N. Y. City.....	159
United Gas Improvement Co., Phila., Pa.....	153
Henry Pratt & Co., Chicago, Ill.....	159
National Gas Light and Fuel Co., Chicago, Ills.....	154
Simpkin & Hillyer, Richmond, Va.....	148

PROCESSES.

National Gas Light and Fuel Co., Chicago, Ills.....	154
Bartlett, Hayward & Co., Baltimore, Md.....	161
Wm. Henry White, N. Y. City.....	148
United Gas Improvement Co., Phila., Pa.....	153
Henry Pratt & Co., Chicago, Ill.....	159

INCLINED RETORTS.

Laclede Fire Brick Manuf'g Co., St. Louis, Mo.....	115
--	-----

GASHOLDER TANKS.

W. C. Whyte, New York City.. ..	154
J. P. Whittier, Brooklyn, N. Y.....	148

GASHOLDER PAINT.

The Government Waterproof Paint Co., Boston, Mass.....	148
--	-----

RETORTS AND FIREBRICK.

J. H. Gautier & Co., Jersey City, N. J.....	158
B. Kreischer & Sons, New York City.....	158
Adam Weber, New York City.....	158
Laclede Fire Brick Manuf'g Co., St. Louis, Mo.....	158
Brooklyn Retort and Fire Brick Works, Brooklyn, N. Y.....	158
Borgner & O'Brien, Phila., Pa.....	158
James Garduer, Jr., Pittsburgh, Pa.....	158
Henry Maurer & Son, New York city.....	159
Chicago Retort and Fire Brick Co., Chicago, Ills.....	158
Baltimore Retort and Fire Brick Co., Baltimore.....	158
Oakhill Gas Retort and Fire Brick Co., St. Louis, Mo.....	158

SCRUBBERS AND CONDENSERS.

G. Shepard Page, New York City.....	116
R. D. Wood & Co., Phila., Pa.....	162

REGENERATIVE FURNACES.

Bartlett, Hayward & Co., Baltimore, Md.....	161
Fred. Bredel, New York City	159
Chicago Retort and Firebrick Co., Chicago, Ills.....	158
Wm. Henry White, N. Y. City.....	148
J. H. Gautier & Co., Jersey City, N. J.....	159

GAS GOVERNORS.

Connelly & Co., New York City.....	155
Fred. Bredel, N. Y. City.....	159
Friedrich Lux, London, England.. ..	147

SELF-SEALING MOUTHPIECE DOORS.

Smith & Sayre Mfg. Co., New York City.....	159
--	-----

TAR AND CARBONIC ACID EXTRACTOR.

Geo. Shepard Page, N. Y. City.....	152
------------------------------------	-----

PURIFYING MACHINES.

C. & W. Walker, London, England.....	150
--------------------------------------	-----

CEMENTS.

C. L. Gerould & Co., Brooklyn, N. Y.....	158
--	-----

GAS ENRICHERS.

Standard Oil Co., Cleveland, Ohio	164
---	-----

GAS METERS.

John J. Griffin & Co., Phila., Pa..... 166
 American Meter Co., New York and Philadelphia.... 167
 The Goodwin Gas Stove and Meter Co., Philadelphia, Pa... 167
 Helme & McIlhenny, Phila., Pa..... 167
 D. McDonald & Co. Albany, N. Y..... 167
 Nathaniel Tufts, Boston, Mass..... 166
 Maryland Meter and Manufacturing Co., Baltimore, Md... 166
 John Hillen, Brooklyn, N. Y..... 167
 Bell & Jones, Philadelphia, Pa..... 166

EXHAUSTERS.

P. H. & F. M. Roots, Connersville, Ind..... 162
 Smith & Sayre Manufacturing Co., New York City..... 163
 Wilbraham Bros., Philadelphia, Pa..... 155
 Connelly & Co., New York City..... 155

GAS COALS.

Penn Gas Coal Co., Phila., Pa..... 165
 Perkins & Co., New York City..... 164
 Newburgh Orrel Coal Co., Baltimore Md..... 165
 Despard Coal Co., Baltimore, Md..... 165
 Chesapeake and Ohio R. R. Coal Agency, N. Y. City..... 165
 Westmoreland Coal Company, Phila., Pa..... 165
 J. & W. Wood, New York City..... 164

CANNEL COALS.

Perkins & Co., New York City..... 164
 J. & W. Wood, New York City..... 164

VALVES.

Ludlow Valve Manufacturing Co., Troy, N. Y..... 156
 John McLean, New York City..... 156
 Chapman Valve Manufacturing Co., Boston, Mass..... 156
 R. D. Wood & Co., Phila., Pa..... 162

GAS ENGINES.

Schleicher, Schumm & Co., Phila., Pa..... 132
 Clerk Gas Engine Co., Phila., Pa..... 156
 Van Duzen Gas Engine Co., Cincinnati, Ohio..... 156

ENGINES AND BOILERS.

Jarvis Engineering Co., Boston, Mass..... 155
 Ball Engine Co., Erie, Pa..... 147
 Westinghouse Machine Co., Pittsburgh, Pa..... 155

GAS LAMPS.

G. Shepard Page, New York City..... 156
 Standard Gas Lamp Co., Phila., Pa..... 148
 Welsbach Incandescent Gas Light Co., Phila., Pa..... 149
 The Siemens-Lungren Company, Philadelphia, Pa..... 149

PURIFIER SCREENS.

John Cabot, New York City..... 156
 Bartlett, Hayward & Co., Baltimore. Md..... 156

GAS STOVES.

American Meter Co., New York and Philadelphia..... 157
 The Goodwin Gas Stove and Meter Co., Phila. Pa..... 168
 George M. Clark & Company, Chicago, Ills..... 149
 D. McDonald & Co., Albany, N. Y..... 167
 Maryland Meter and Manufacturing Co., Baltimore, Md... 166
 Bell & Jones, Philadelphia, Pa..... 166

STREET LAMPS.

J. G. Miner, Morrisania, New York City..... 113
 Bartlett Street Lamp Man'fg Co., New York City..... 148

BURNERS.

C. A. Gefroerer, Phila., Pa..... 164

STEAM BLOWER FOR BURNING BREASE.

H. E. Parson, New York City..... 120

PURIFYING MATERIAL.

Connelly & Co., New York City..... 155
 Friedrich Lux, London, England..... 147
 Edgewater Lime Works, Edgewater, N. J..... 147

COKE CRUSHER.

C. M. Keller, Columbus, Ind..... 165

ELECTRICAL APPARATUS.

Wm. Henry White, N. Y. City..... 148

SOLVENTS.

Maas & Waldstein, New York City..... 148

BOOKS, ETC.

Gerould's System Gas Bookkeeping..... 147
 1889. Directory. 1889..... 158
 King's Treatise..... 165
 Scientific Books..... 150
 Management of Small Gas Works..... 156
 Gas vs. Electricity..... 148
 Practical Electric Lighting..... 155
 Electric Light Primer..... 155
 American Gas Engineer and Superintendents' Handbook... 165
 Digest of Gas Law..... 165
 Fuel and its Applications..... 147

POSITION WANTED.

A Mechanical Engineer,

Experienced in Gas Manufacture, wishes a position as Superintendent of a Gas Works. Best of references given and asked Salary, \$1,200.

"MECHANICAL ENGINEER," care this Journal,
 765-1f or Box 972, West Bay City, Mich

Position Desired

By a man of practical experience in TESTING, SETTING, and REPAIRING METERS, STOVE WORK, COMPLAINTS, LAYING OF MAINS, SERVICES, ETC. Could manage a works of 20 millions. References A1.

766-2 "J. J. D.," care this Journal.

Position Wanted

As Superintendent or Assistant of a Gas Works,

By a man who can give the best of references. Thoroughly understands the manufacture and distribution of gas and the construction of works. Address

765-5 "M.," care this Journal.

Position Wanted

As Superintendent or Assistant,

Or Inspector of Meters, and all outside and inside work. Has had many years' experience; ten years in last employ. Best of references. Address

764-1 "W. A.," care this Journal.

FOR SALE.

**A Complete Water Gas Plant.
 60,000 Cu. Ft. Daily Capacity.**

Fully equipped; all the latest improvements; includes Generator, Purifiers, and Holder. Can be removed to any part of the country, and set up at small cost. For further information apply to BRADFORD GAS LT. & HEATING CO., Dunkirk, N. Y.

FOR SALE,

One 5-ft. Station Meter.
 One Hydranlic Main (five sections), wrought iron, 22 by 24, with Bye-Pass on Dip-Pipes.

25 Valves, Stand-Pipes, 7-inch Mouthpieces and Lids, all complete, ready for use, to fit up five benches of 5's.

This apparatus is all in first-class condition.
 Price, \$800, f.o.b. cars or boat, Poughkeepsie, N. Y.

Inquiries may be sent to this Office.

GAS WORKS FOR SALE.

A CONTROLLING INTEREST IN SEVERAL
Interior California Coal Gas Plants,

now paying handsomely, are offered on very reasonable terms. This is an exceptionally good opportunity for practical gas men of limited means, wishing to remove to a mild and healthful climate, to acquire an established and paying business. Particulars given and full investigation solicited.

760-3 mos. SECRETARY, 123 Beale Street, San Francisco, Cal.

6 PER CENT.

**First Mortgage Bonds
 ON GAS WORKS**

SITUATED IN GROWING WESTERN TOWNS.

Principal and Interest Guaranteed.

INTEREST SEMI-ANNUALLY.

For sale by the undersigned, who will furnish all necessary information regarding them.

JOS. R. THOMAS, 42 Pine St., N. Y. City.

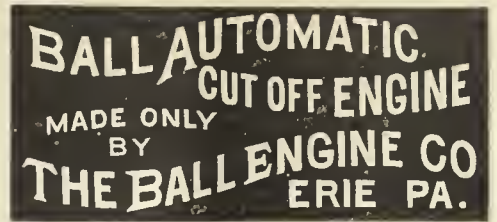

Fuel and Its Applications.

By E. J. MILLS, D.Sc. F.R.S., and F. J. ROWAN, C.E., assisted by others, including Mr. F. P. Dewey, of the Smithsonian Inst., Wash., D. C.

7 PLATES, AND 607 OTHER ILLUSTRATIONS. ROYAL OCTAVO, PAGES XX, 802. HANDSOME CLOTH, \$7.50.

A. M. CALLENDER & CO., 42 Pine St., N. Y.

GEROULD'S

System Gas Bookkeeping.

Approved and adopted by many of the prominent Gas Engineers of the Country.

Sample Sheets and Price-List furnished free on application to

L. P. GEROULD, - - Mendota Ill.

EDGEWATER LIME WORKS

Chas. F. McKenna, Proprietor.

SHELL LIME.

Lime by the Cargo for Gas Purification.

EDGEWATER, BERGEN CO., N. J.

Write for Testimonials and Prices.

FRIEDRICH LUX,

Ludwigshafen am Rhein and London.

**Lux Mass
 GAS GOVERNORS,
 Gas Balance.**

PATENTS.

FRANKLIN H. HOUGH

Solicitor of American & Foreign Patents.

925 F. ST., WASHINGTON, D. C.

(NEAR U. S. PATENT OFFICE.)

Personal attention given to the preparation and prosecution of applications for Letters Patent. All business before the U. S. Patent Office attended to for moderate fees. No Agency in the United States possesses superior facilities for obtaining Patents, or for ascertaining the patentability of inventions. Copies of patents furnished for 25 cents each. Correspondence solicited.

Simpkin & Hillyer

RICHMOND, VA.

MANUFACTURERS OF

Gas Works Apparatus

BENCH CASTINGS, CONDENSERS,
Scrubbers, Purifiers, Dry Center Seals,
FOUR-WAY VALVES, GAS VALVES,
SULPHATE OF AMMONIA APPARATUS,
TANKS, ENGINES, BOILERS,
PUMPS, ETC., ETC.

Plans, Specifications and Estimates furnished for new works, or alteration of old works. Correspondence solicited. Works, Newport News, Va.

Bartlett Street Lamp Mfg. Co.

MANUFACTURERS OF

Globe Lamps,

FOR

Streets, Parks, Public Buildings, Railroad Stations, etc.

LAMP POSTS

A Specialty.

Office and Salesroom,

40 & 42 COLLEGE PLACE, - - N. Y. CITY.

Gas Companies and others intending to erect Lamps and Posts will do well to communicate with us.

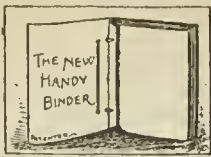

THE NEW HANDY BINDER.

This article may be described as elegant in appearance, strong, durable, and possessing many special qualities of its own. It allows the opening of the pages perfectly flat, whether one or several numbers are in the binder. Any number can be taken out and replaced without disturbing the others. The papers are not mutilated for subsequent binding in permanent form. The binder is supplied with gilt side title, and is an ornament to any desk or reading table. The JOURNAL, filed in the Handy Binder, becomes a volume of great value, always convenient for instant reference. Handy Binder, Postage paid, \$1.00.

A. M. CALLENDER & CO., 42 Pine St., N. Y.

GAS vs. ELECTRIC LIGHT.

We would invite attention to the able and exhaustive argument of General A. Hickenlooper, President of the Cincinnati Gas Light and Coke Company, contained in a handsome pamphlet of 96 pages, entitled

"EDISON'S INCANDESCENT ELECTRIC LIGHTS FOR STREET ILLUMINATION. REPORT OF AN ARGUMENT DELIVERED BY A. HICKENLOOPER BEFORE THE COMMITTEE ON LIGHT, MUNICIPAL COUNCIL, CITY OF CINCINNATI, JULY 22, 1886."

This is a subject of special interest to all Gas Light Companies.

Prices.

25 copies.....	\$7.50	100 copies.....	\$22.50
50 copies.....	12.50	250 copies.....	50.00

A sample copy will be sent by mail on receipt of 50 cts
 A. M. CALLENDER & CO., 42 PINE ST., N. Y. CITY

PHILADELPHIA.

STEPHEN A. MORSE, President.
 GODFREY REBMANN, Vice-Pres.

NEW YORK.

EDWIN F. MORSE, Secretary.
 CARLTON M. WILLIAMS, Treas.

CHICAGO.



STANDARD GAS LAMP CO.,

Main Office, 411 Cherry St. Factory, 1101, 1103, 1105 Frankford Av.

PHILADELPHIA, PA.

It is to the interest of Gas Companies and Cities to double the efficiency of the light on streets by using Dyott's Patent "CHAMPION" LAMPS. They save 50 per cent. over others in cost of repairs, are ornamental, and indestructible except by violence.

Our Patent System of Instantaneously Lighting Gas (without electricity), for Railroad Depots is unequalled.

Dyott's High Candle Power Burner is a very superior lamp where a concentrated and brilliant light is wanted in Hotels, Stores, Depots, etc.

Special Drawings furnished and Estimates cheerfully given, either from Architects', Engineers', or our Draughtmen's Plans.

We manufacture every description of Plain and Ornamental Lamps, Posts, Brackets, Clusters, etc. Correspondence solicited.

No. 29 Champion.

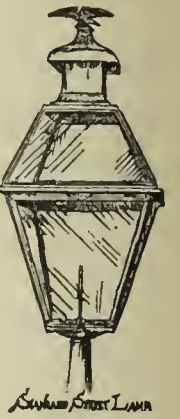

GASHOLDER PAINT.

Use Only

THE GOVERNMENT WATERPROOF PAINT.

Proof against Ammonia, and Absolutely Waterproof. Send for Prices and Particulars.

THE GOVERNMENT WATERPROOF PAINT CO., 122 Milk Street, Boston, Mass.

WM. HENRY WHITE,

No. 32 Pine Street, - - - New York City.

ENGINEER AND CONTRACTOR FOR THE

Erection and Extension of Gas, Water, and Electric Light Works.

SOLE REPRESENTATIVE OF THE

McILHENNY REGENERATOR FURNACE PATENTS

And the Martin Water Gas Process.

Edison Incandescent and American Arc Electric Light Plants Installed.

Correspondence with Gas Companies contemplating extending or improving their Plants respectfully invited. Plans and Estimates Furnished.

(Patented.)

IMPORTANT!

(Patented)

NEW SOLVENT FOR GAS PIPE DEPOSITS.

Economical and Effective.

MAAS & WALDSTEIN, 44 Trinity Place and 81 Greenwich St., N. Y.

Gasholder Tanks & Gas Works Masonry Complete.

PLANS PREPARED AND ESTIMATES FURNISHED AT SHORT NOTICE.

J. P. WHITTIER, - - 499 Wythe Av., Brooklyn, N. Y.

The Gordon Portico Lamp.

A successful Competitor of the Arc Electric Light for lighting Store Fronts, Show Windows, Depots, Railway Sheds, etc., etc.

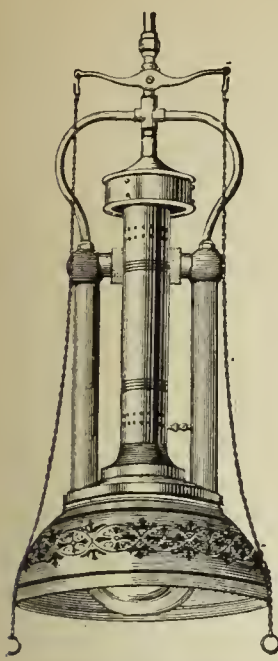

Gordon Portico Lamp.

The Gordon Street Lamp.

A Successful Competitor of the Arc Electric Light for lighting Streets, etc., etc.

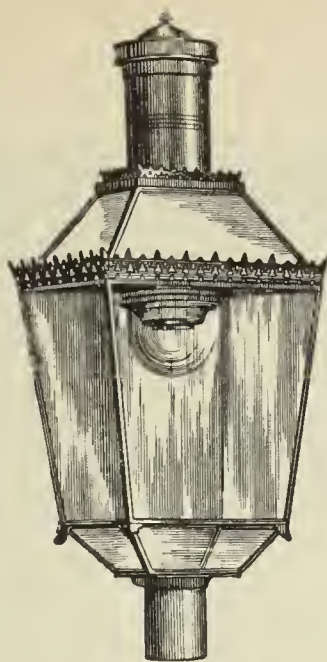

Gordon Street Lamp.

The Lungren Lamp.

A Successful Competitor of the Incandescent Electric Light for Interiors, etc. Is especially applicable for the lighting of Offices, Stores, Factories, Mills, Show Windows, Libraries, and all situations where an increased illumination is desired.

More than 25,000 Lungren Lamps are now in use. Testimonials, references, or any desired information will be cheerfully given.



Lungren Lamp.

THE SIEMENS-LUNGREN CO., N.E. Cor. 21st St. & Washington Av., PHILADELPHIA.

WELSBACH SYSTEM OF Incandescent Gas Lighting.

OFFICE, DREXEL BUILDING, PHILA., PA.

At the Fall Session of the Board of Supervisors of Winnebago County, held at the County Court House, Oshkosh, Wis., Nov. 26, 1889, the report submitted by Mr. C. W. Cook, Chairman of the Committee on Public Buildings, recommending the use of the Welsbach Incandescent Gas Burner in the Buildings under their charge, was unanimously adopted, because of the extreme economy in the consumption of Gas and the superior character of the light obtained.

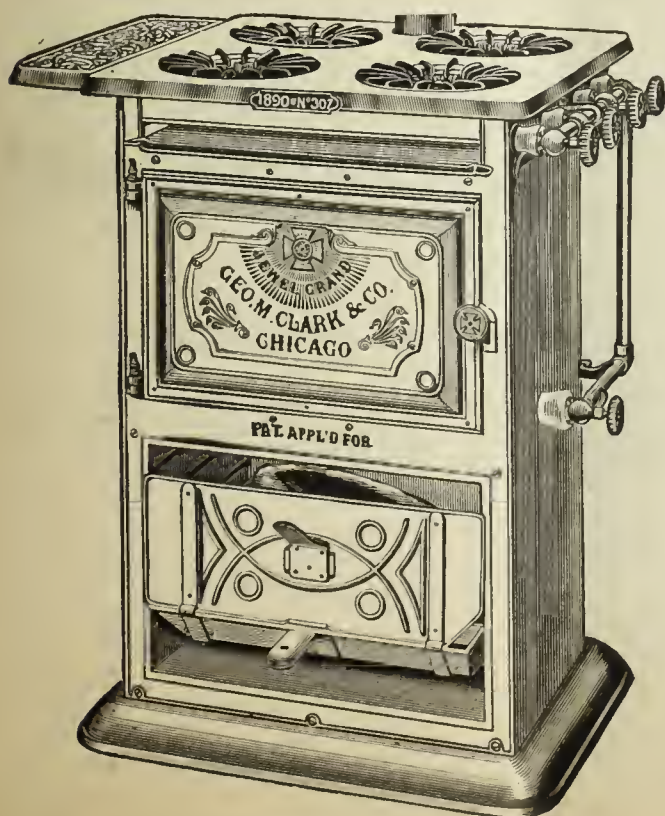

JEWEL GAS STOVES

MANUFACTURED BY

GEORGE M. CLARK & COMPANY,

Nos. 157 & 159 Superior Street, - - - Chicago, Ill.

EVERY CONCEIVABLE SIZE AND STYLE,

Ranging in Prices from \$1.50 to \$30.00.

WE USE NO GAS COCKS.

All Flames are Regulated by a Direct Needle Valve.

The JEWEL

IS THE

Only Well-Made Gas Stove on the Market.

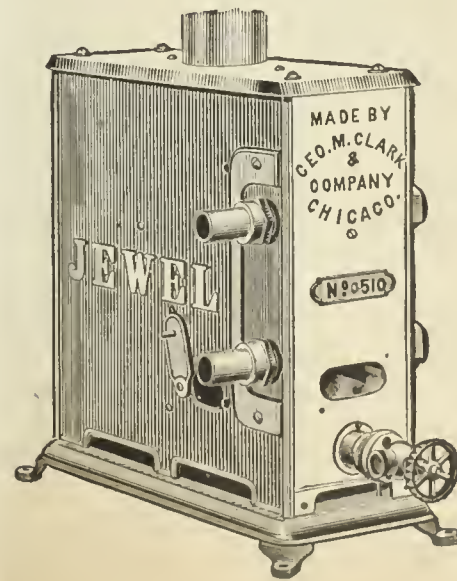

Write for our 1890 Catalogue and see for yourself.

C. & W. WALKER'S PAT. PURIFYING MACHINE.

TAKING ALL THE WORK FROM THE OUTLET OF THE CONDENSER TO THE INLET OF THE PURIFIERS.

Patented in Great Britain and Ireland, Australia, France Germany, Italy, and the United States.

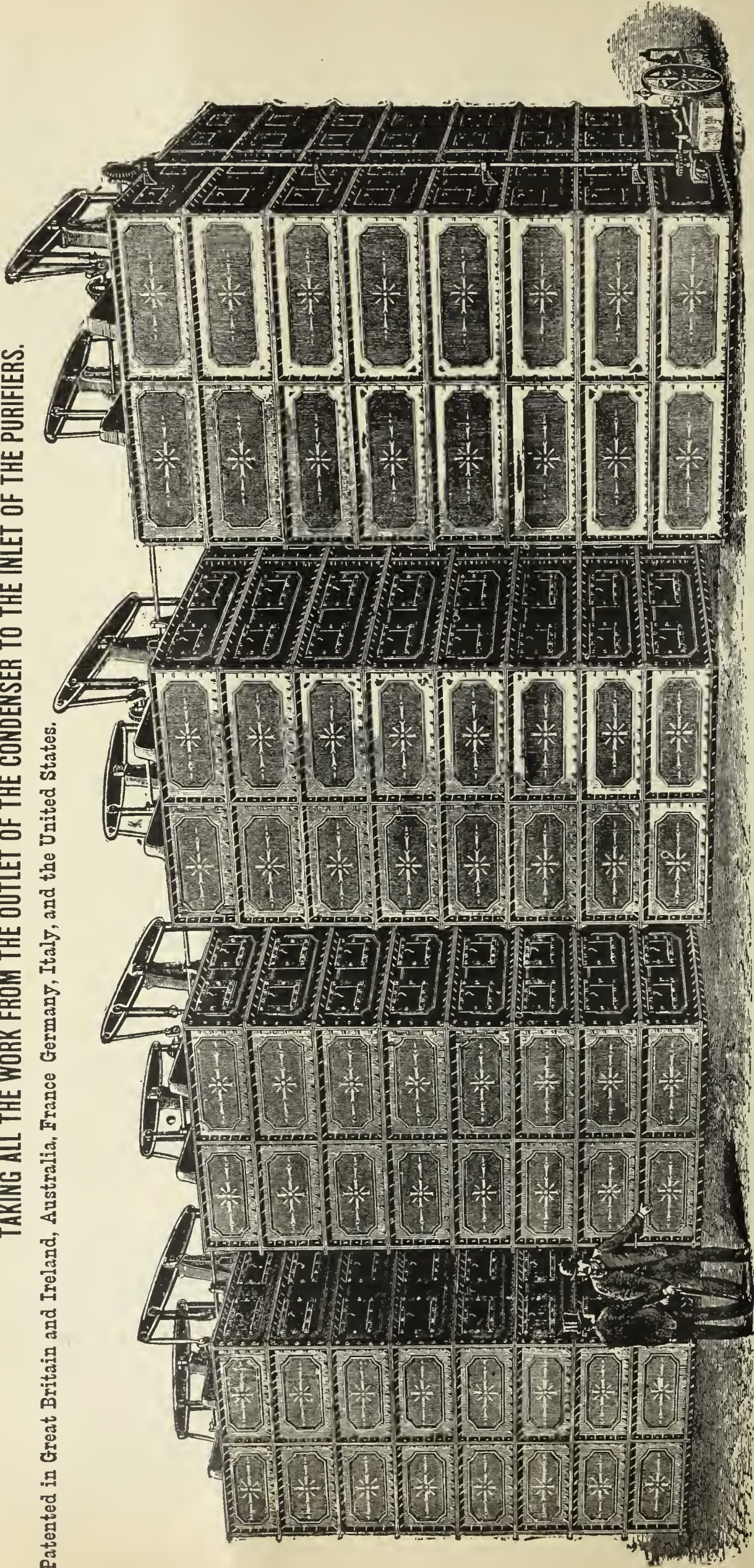

These Four Machines Purify 12 Millions per Day, and only occupy a Ground Space of 60 ft. by 12 ft., and are 23 ft. 6 in. High.

Four of these powerful Machines for the new extensions at the Beckton Gas Works, London, are now working, purifying Twelve Million Cubic Feet of Gas per day, each Machine taking Three Millions per day.

These Machines can be seen at Beckton, where, after being long and abundantly tried, tested, and proved in every variety of working, have been accepted by the Gas Light and Coke Company, of London, as superior to all other apparatus for taking all the work of the purification of gas between the Condensers and the Purifiers.

The Machine is the most important improvement effected in gas works for years past. The purifying power developed is most remarkable. We send an Engineer with a working model to any Gas Company inviting information. It is equally adapted to gas works of any size.

DESCRIPTION.

The gas enters into the washing chamber at the lowermost part, where it is first subjected to a thorough washing in the strong Ammoniacal Liquor. The washing is most effective. The entire surface of the Ammoniacal Liquor is in a bubbling state of ebullition, presenting an

agitated, frothy surface all over. All the Tar left in the gas after surface condensation is here completely extracted, and a large amount of Carbonic Acid.

The gas, thus so far purified, ascends from the washing chamber and passes from one superposed chamber to another in contact with the enormous amount of movable, constantly dipping wetted surfaces, leaving the uppermost chamber entirely purified from Ammonia, meeting the chemical requirements of the Board of Trade.

The Machine is self-cleansing, and can never choke or stop up; and in this important respect it is superior to all Machines heretofore known. The space occupied by the Machine is very small. In most cases it can be placed in the space inside the end of the Purifying House. Its cost is less than any other known apparatus for purifying gas from Tar and Ammonia.

These Machines are at work and in hand for Widnes, Burnley, and Oswaldtwistle, in Lancashire; at Harrogate and Wakefield, in Yorkshire; at Stalybridge, in Cheshire; at Stone, in Staffordshire; also at Cheltenham and Northampton, also at Melbourne, in Australia.

Apply, until American Agency is appointed, to

C. & W. WALKER, 8 Finsbury Circus, London.

THIS SPACE
WILL BE
Occupied Next Month by the
KERR MURRAY MFG. CO.
FORT WAYNE, IND.
**GAS WORKS
APPARATUS
AND
HOLDERS.**

DAVIS & FARNUM MFG. CO.,
WALTHAM, MASS.

PRINCIPAL OFFICE AND WORKS, Waltham, Mass.

BOSTON OFFICE, Room 55, Mason Building, 70 Kilby Street.

SINGLE, DOUBLE,
AND
TRIPLE LIFT

Gas holders.

OF ANY CAPACITY.

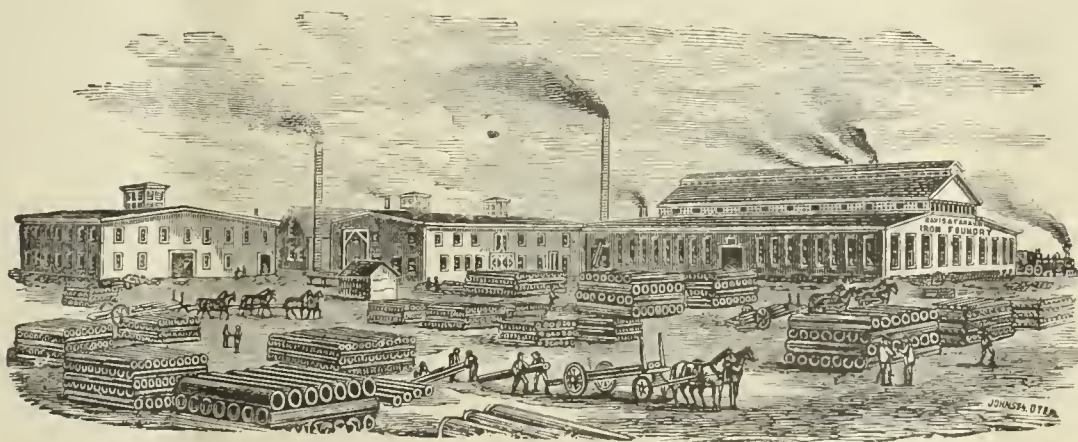

TUBULAR, PIPE,
AND
SINUOUS FRICTION

Condensers.

OF ALL SIZES.

IRON ROOF FRAMES AND FLOORS.

Purifying Boxes, Center Seal or Valve Connections, Bench Work.

Reversible Lime Trays.

SELF-SEALING AND PRESSED STEEL MOUTHPIECE LIDS.

Coke Barrows, Coal Wagons, and all Apparatus Requisite for a Complete Gas Plant.

— ALSO —

Gas and Water Pipe, Flanged Pipe,

Sugar House Work, and Special Castings of all Descriptions.

THE WALKER TAR AND CARBONIC ACID EXTRACTOR.

A very general demand exists, in both large and small Gas Works, for an apparatus that will be absolutely efficient in the removal of the tar which passes the hydraulic main and condenser. Many attempts have been made to accomplish this, but, I believe, without success, until the introduction, five years ago, in England, of the C. & W. Walker Patent Tar and Carbonic Acid Extractor. During these years this apparatus has been adopted by many of the most prominent Engineers, not only in England, but also on the Continent of Europe and in other parts of the world. It is only necessary to give here a partial list in order to convince any intelligent American Gas Engineer that this machine must have succeeded fully in accomplishing the desired results.

The following Engineers have personally given permission to refer to them:

G. C. Trewby, Esq., Engineer-in-Chief of the Gas Light and Coke Co., London. The manufacturing plant at Beckton is built in complete sections of 3,000,000 cubic feet capacity each. A Walker Tar Extractor has been fitted to each one of these sections. This was done after a long and thorough trial on one of its sections. The Tar Extractor has been supplied to other works of the Gas Light and Coke Co., including those of which John Methven, Engineer of the Gas Light and Coke Co. at the Nine Elms Station, is in charge. Also to G. E. Stevenson, Peterborough Gas Works; B. Green, Mitcham and Wimbledon Gas Works; W. H. Smith, Bedford Gas Works; F. Linging, Norwich Gas Works; J. T. Browning, Colchester Gas Works; S. B. Darwin, Portsmouth Gas Works; J. McCrae, Dundee Gas Works; W. J. Wells, Stamford Gas Works; J. M. Darwin, Longton Gas Works; J. Paterson, Warrington Gas Works; and J. Coulter, of the Dundalk Gas Works. All of the foregoing gas works are located in Great Britain.

Mr. Charles A. Gerdenier, Superintendent of the Bridgeport (Conn.) Gas Light Company, writes as follows, under date of Dec. 3, 1887:

"The C. & W. Walker Tar and Carbonic Acid Extractor has been in operation at these works for the past six weeks, and is an unqualified success. It removes every particle of Tar from the gas in once passing through the apparatus, and a large percentage of the Carbonic Acid. I also feel quite sure that it prevents the formation and deposit of Naphthaline, because since I started the Washer I have had no stoppages from this cause. These works have been seriously troubled with Tar for many years, and I have used several kinds of apparatus and every expedient which has come to my attention for dealing with the difficulty, but without success. The Walker apparatus occupies comparatively small space, is less expensive than other systems, and requires but little attention. I carry 2½-inch seal, and have an automatic tar delivery valve. This Tar Extractor is indispensable to gas makers."

I have taken the Agency for the United States for this apparatus, and am now prepared to make contracts to erect it on the premises of any Gas Company. It would be manufactured in the following sizes:

No. 1,	50,000 to	100,000	cu. ft. per 24 hrs.,	3 ft. square,	5 ft. deep.
No. 2,	" "	125,000	" " "	4 " " "	" "
No. 3,	" "	250,000	" " "	5 " " "	" "
No. 4,	" "	500,000	" " "	6 " " "	" "
No. 5,	" "	750,000	" " "	7 " " "	" "
No. 6,	" "	1,000,000	" " "	8 " " "	" "
No. 7,	" "	1,250,000	" " "	9 " " "	" "
No. 8,	" "	1,500,000	" " "	10 " " "	" "
No. 9,	" "	2,000,000	" " "	12 " " "	" "
No. 10,	" "	3,000,000	" " "	15 " " "	" "

This Tar Extractor will perform its work with about one-fourth the usual back-pressure heretofore required. It is simple in construction, and can be supplied at a very reasonable price—less than any other ever before introduced. Satisfactory results will be guaranteed in every instance.

GEO. SHEPARD PAGE,

SOLE AGENT FOR THE UNITED STATES,

No. 69 Wall Street, - - - New York

THE UNITED GAS IMPROVEMENT CO.

DREXEL BUILDING, PHILADELPHIA.

OFFICERS:

WILLIAM W. GIBBS, President.

GEORGE PHILLER, Vice-President.

SAM'L T. BODINE, Gen'l Manager.

RANDAL MORGAN, Gen'l Counsel.

EDWARD C. LEE, Sec'y and Treas.

ALEX. C. HUMPHREYS, Gen'l Supt.

WALTON CLARK, Ass't Gen'l Supt.

H. H. EDGERTON, Chem. and Eng'r.

DIRECTORS:

GEORGE PHILLER,

THOMAS DOLAN

HENRY C. GIBSON,

WM. T. CARTER,

WILLIAM G. WARDEN,

SAM'L T. BODINE.

BUILDERS, LESSEES AND PURCHASERS OF

⌘ GAS WORKS ⌘

Orders solicited from Large Cities, Small Towns, Mills, Institutions, from all who want more Light for Less Money.

NATIONAL GAS LIGHT AND FUEL COMPANY,

No. 218 La Salle Street, Chicago.

THE SPRINGER SYSTEM

OF

Fuel and Illuminating Water Gas Works.

REFERENCES.

People's Gas Lt. & Coke Co.. Chicago, Ill.
 Illinois Light, Heat & Power
 Co..... Chicago, Ill
 Elgin National Watch Co.. Elgin, Ill.
 C. R. I. & P. R. R. Shops.. Chicago, Ill.
 Decatur Gas Lt & Coke Co.. Decatur, Ill.
 Niles Gas Light Co..... Niles, Mich.
 Newton Illuminating Co... Newton, Kansas.
 Wellington Light & Heat Co.. Wellington, Kansas.
 Chippewa Falls Gas Lt. Co.. Chippewa Falls, Wis.
 Elkhart Gas Lt & Coke Co.. Elkhart, Ind.
 Madison City Gas Light Co.. Madison, Wis.
 South Bend Gas Light Co.. South Bend, Ind.
 Sheboygan National Gas Co.. Sheboygan, Wis.
 Salina Gas Light Co..... Salina, Kansas.
 The Rathbun Co..... Deseronto, Prov. Ont.
 Jefferson City Gas Lt. Co.. Jefferson City, Mo.
 Mankato Gas Light Co..... Mankato, Minn.
 Lima Gas Light Co..... Lima, Ohio.

Minneapolis Gas Light and
 Coke Co..... Minneapolis, Minn.
 Bellevue Water and Fuel } Bellevue, Campbell
 Gas Light Co..... } County, Ky.
 Bucyrus Gas Lt. & Fuel Co.. Bucyrus, Ohio.
 Morris Gas Co..... Morris, Ill.
 Los Angeles Gas Co..... Los Angeles, Cal.
 San Diego Gas Fuel & Elec-
 tric Lt. Co..... San Diego, Cal.
 Sioux Falls Gas Co..... Sioux Falls, Dak.
 Dakota Gas and Fuel Co.. Grand Forks, Dak.
 St. Johns Mutual Gas Co... St. Johns, Mich.
 Stillwater Gas Light Co... Stillwater, Minn.
 St. Paul Gas Light Co..... St. Paul, Minn.
 Emporia Electric and Gas
 Light Co..... Emporia, Kas.
 Van Wert Gas Light Co... Van Wert, Ohio.
 Lansing Gas Light Co..... Lansing, Mich.
 San Francisco Gas Lt. Co... San Francisco, Cal.

Shelbyville Gas Light Co... Shelbyville, Ind.
 Great Falls Gas Light Co.. Great Falls, N. H.
 Belleville Gas Co..... Belleville, Ontario
 Rochester Lt. and Fuel Co.. Rochester, Minn.
 Northwestern Gas Light and
 Coke Co..... Evanston, Ill.
 Lincoln Gas Light Co..... Lincoln, Neb.
 Davenport Gas Light Co... Davenport, Iowa.
 Municipal Gas Co..... Albany, N. Y.
 Alliance Gas Light Co..... Alliance, Ohio.
 New Gas Light Co..... Janesville, Wis.
 Chicago Gas Lt. & Coke Co., Chicago, Ill.
 Joliet Gas Co..... Joliet, Ills.
 Superior Light & Fuel Co.. Superior, Wis.
 Kewanee Gas Light Co... Kewanee, Ill.
 Aberdeen Tight & Fuel Co.. Aberdeen, So. Dak.
 Pierre Light and Fuel Co.. Pierre, So. Dak.
 *Standard Gas Light Co... New York City.
 *Carlinville Gas Light Co.. Carlinville, Ill.

* Building.

GUARANTEED ESTIMATES of Cost of Gas Furnished on Application.

GASHOLDER TANK CONSTRUCTION, ETC.

Gas Companies and others about to erect Gasholders will find it profitable to consult
 W. C. Whyte, who for over 30 years has made a specialty of

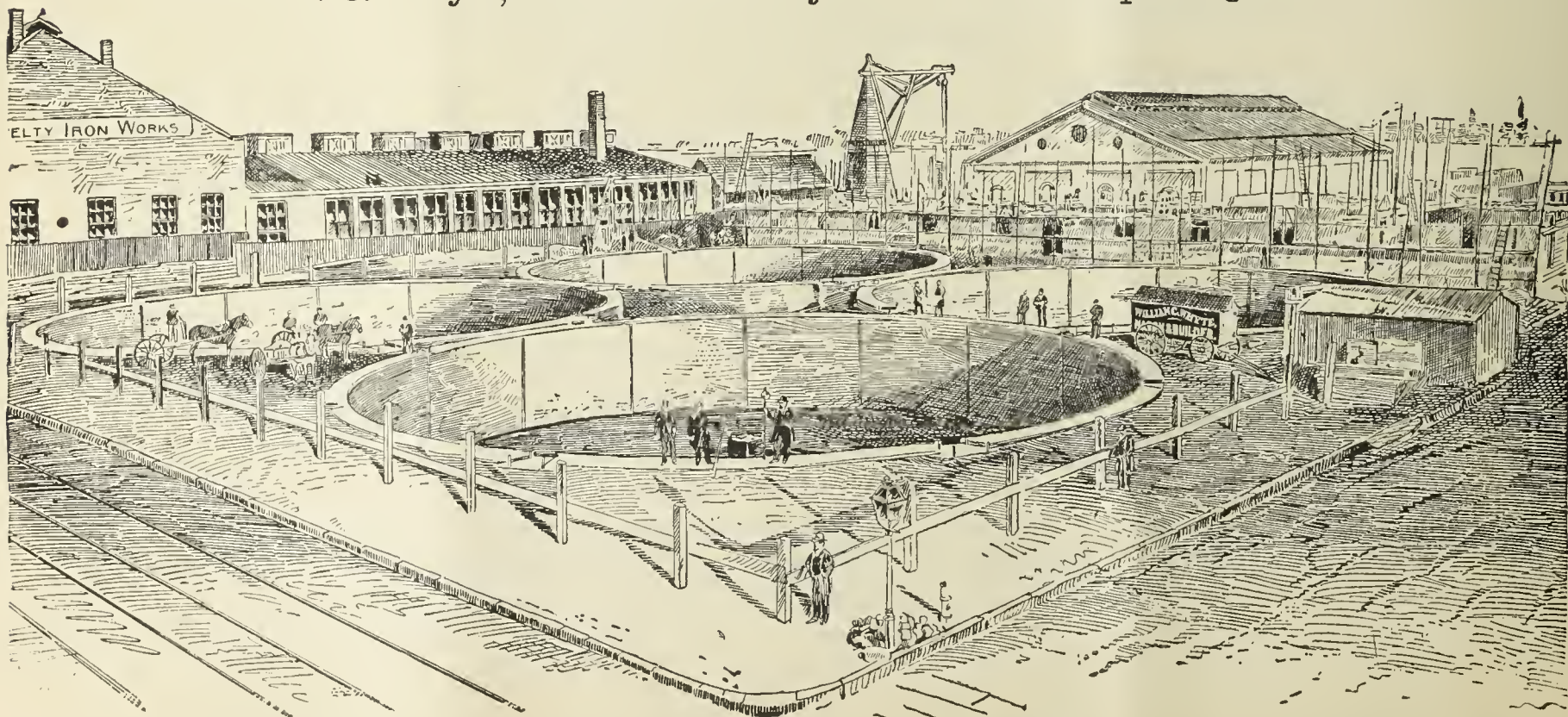

Tank Excavation and Mason Work.

Fifty Tanks now in operation show the sort of work done. Address

W. C. WHYTE, - No. 15 Cortlandt Street, N. Y. City.

CONNELLY & CO.,

SOLE MANUFACTURERS OF THEIR PATENTED SPECIALTIES.

"IRON SPONGE." Saves money, saves labor, and is the most efficient purifying agent ever offered as a substitute for lime. Now used in every State in the Union, and purifying daily over thirty-five million cubic feet. Should be used in every gas works. Its own saving will pay for it many times over.

AUTOMATIC GOVERNOR. Has been on the market but three years, and in that time has been introduced more generally than any invention ever designed for use in gas works. Over two hundred of them now in use. Sensitive; reliable; perfectly automatic; reduces leakage; satisfies consumers, and gives great relief to the Manager. No gas works is complete without one of these machines.

STEAM JET EXHAUSTER. Designed particularly for small works. Combines Exhaust Tube, Steam Governor Gas Compensator, and Bye-Pass Valves in the most compact form possible; occupies but little space; uses very little steam; operated by ordinary workmen; saves formation of carbon in retorts; increases yield 10 to 15 per cent. Specially adapted for mixing air with oil gas. No works too small to use them profitably.

Prices given on all our specialties delivered at any point in the United States. Correspondence solicited.

CONNELLY & CO., No. 111 Broadway, New York City.

WILBRAHAM GAS EXHAUSTER & ENGINE COMBINED.

WILBRAHAM BROS.,
PHILADELPHIA, PA.

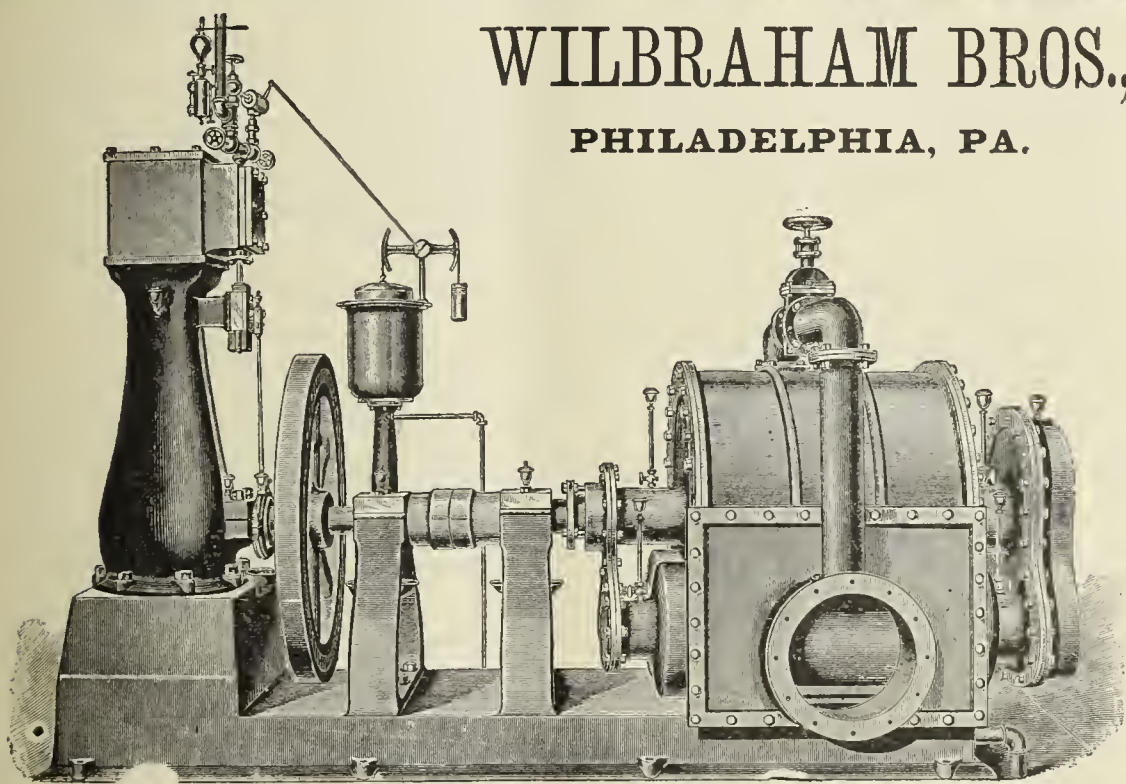

JARVIS ENGINEERING CO.,

61 Oliver St., Boston, Mass.

CONTRACTORS FOR ERECTING

COMPLETE STEAM OUTFITS FOR ELECTRIC LIGHTING STATIONS.

Steel Boilers set with Jarvis Pat. Boiler Setting

To burn **COKE SCREENINGS** for Fuel.

ARMINGTON & SIMS CO. ENGINES,

Belting direct to Dynamos, without using Shafting.

SEND FOR CIRCULARS.

REFERENCES.—Charlestown Gas & Electric Light Co., Charlestown, Mass.; Schenectady Gas & Electric Light Co., Schenectady N. Y.; Brookline Gas Co., Brookline, Mass.

Practical Electric Lighting

By A. BROMLEY HOLMES, A.M.I.C.E.

With 87 Illustrations. Third Edition. Price, \$1.00.

Electric Light Primer.

By CHARLES L. LEVEY.

A simple and comprehensive Digest of all the most important facts connected with the running of the Dynamo and Electric Lights, with Precautions for Safety, etc.

Price, 50 cents.

A. M. CALLENDER & CO., 42 Pine St., N.Y.

COMPOUND

Condensing or Non-Condensing.

16 SIZES, 5 to 500 H. P.

Not yet equaled by any form of Engine for HIGH FUEL DUTY AND SIMPLICITY.

STANDARD

13 Sizes in Stock, 5 to 250 H. P.

3000 in use in all parts of the Civilized World.

JUNIOR

6 Sizes in Stock, 5 to 50 H. P.

An Automatic Engine cheaper than a Slide Valve. WELL BUILT. ECONOMICAL. RELIABLE.

Over 300 Sold the First Year.

All the above built strictly to Gauge with INTERCHANGEABLE PARTS.

REPAIRS CARRIED IN STOCK.

SEND FOR ILLUSTRATED CATALOGUES.

WESTINGHOUSE ENGINES
 The Westinghouse Machine Co.
 PITTSBURGH, PA. U.S.A.

SELLING DEPARTMENT IN THE UNITED STATES.

New York,	47 Cortlandt St.	} Westinghouse, Church, Kerr & Co.
Boston,	Hathaway Building,	
Pittsburgh,	Westinghouse Build'g,	
Chicago,	156, 158 Lake St.	
Philadelphia,	608 Chestnut St. M. R. Muckle, Jr. & Co.	
St. Louis,	302, 304 Washington Av.	} Fairbanks & Co.
Kansas City,	312 Union Avenue,	
Denver,	1330 Seventeenth St.	
Omaha,	1619 Capitol Avenue, F. C. Ayer.	
Pine Bluffs, Ark.	Geo. M. Dilley & Sons.	
Salt Lake City,	256 S. Main St.	} Utah & Montana Machinery Co.
Butte, Mont.	1. Granite St.	
San Francisco,	24, 23 Fremont Street, Parke & Lacy Co.	
Portland, Or.	33, 35 N. Front St. Parke & Lacy Mch. Co.	
Charlotte, N. C.	36 College St.	} The D. A. Tompkins Co.
Atlanta, Ga.	45 S. Prior St.	
Dallas, Tex.	Keating Imp. & Machine Co.	
Chattanooga, Tenn.,	C. E. James & Co.	



CHAPMAN VALVE MANUFACTURING CO.,

MANUFACTURERS OF

Valves and Gates for Gas, Ammonia, Water, Etc.

Also, Gate Fire Hydrants With and Without Independent Nozzle Valve. All Work Guaranteed.

WORKS & GEN'L OFFICE:
Indian Orchard, Mass.

TREASURER'S OFFICE:
72 Kilby & 112 Milk Sts, Boston, Mass.

LUDLOW VALVE MFG. CO.

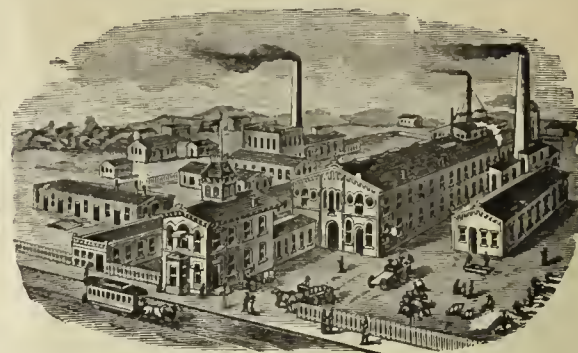

OFFICE AND WORKS,

938 to 954 River Street and 67 to 83 Vall Av.,
TROY, N. Y.

GEO. SHEPARD PAGE,

No. 69 Wall Street, N. Y. City.

REPRESENTING

THE BOWER GAS LAMP.

C. & W. Walker's Carbonic Acid & Tar Extracting Washer

B. DONKIN & CO.'S PAT. IMP. GAS VALVE.

Young & Beilby's Patents. Henry Aitkin's Patents.

R. P. SPICE, London, Eng. HENRY SIMON, Manchester, Eng.

Hydraulic Main Dip Regulators, also
Check Valves, Foot Valves, Yard-
wash and Fire Hydrants.
Send for Circulars.

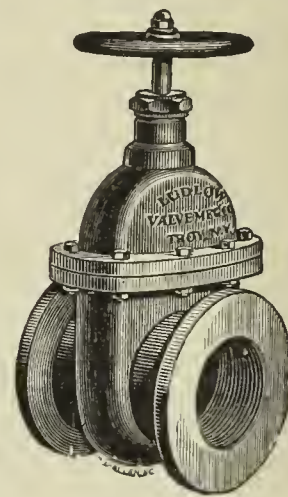

Valves.—Double and Single Gate, ½ in. to
48 in., outside and inside Screws. Indica-
tor, etc., for Gas, Water, Steam, and Oil.
Send for Circulars.

MILLS' REVERSIBLE LIME TRAY,

AND

WOODWORK

Of Every Description

NEEDED BY GAS WORKS.

SEND FOR CIRCULAR AND PRICE LIST TO

BARTLETT, HAYWARD & CO.,

Pratt and Scott Streets, Baltimore, Md.

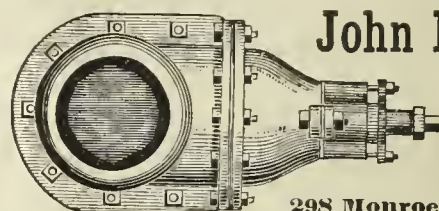
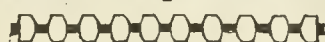
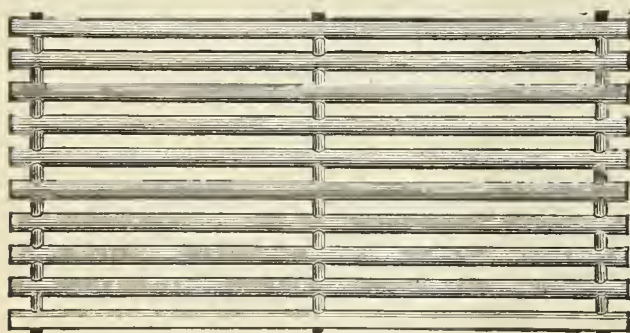

John McLean

Man'facturer

**GAS
VALVES.**

298 Monroe Street, N. Y.

SPECIAL TRAYS FOR IRON SPONGE OR OXIDE OF IRON.
CHURCH'S TRAYS A SPECIALTY.

REVERSIBLE-STRONGEST-MOST DURABLE-MOST EASILY REPAIRED.

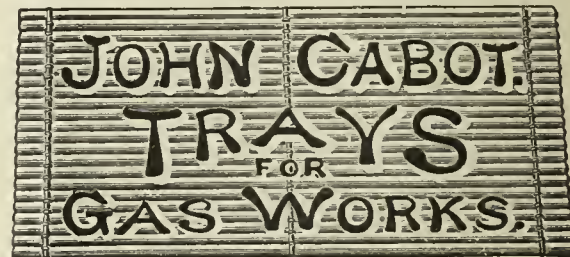

306-310 ELEVENTH AVENUE, NEW YORK.

WE ALSO MAKE THE CHEAPEST AND STRONGEST
REVERSIBLE BOLTED TRAYS IN THE MARKET.

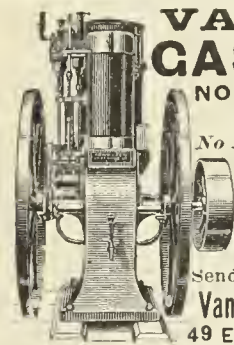

**VAN DUZEN
GAS ENGINE**

NO BOILER. NO COAL.
NO ENGINEER.

No Extra WATER RENT
or INSURANCE.

INSTANTLY STARTED.
DURABLE, RELIABLE,
SAFE and ECONOMICAL.

Send for description and prices.

Van Duzen Gas Engine CO.,

49 E. 2nd St., CINCINNATI, O.

A. MacKinnon Machine Co., Agts., 22 Warren St., N.Y.

**The Management of Small
Gas Works.**

BY C. J. R. HUMPHREYS.

Price, \$1.

Orders to be sent to **A. M. CALLENDER & CO.,**

42 PINE STREET, NEW YORK.

THE CLERK GAS ENGINE CO.,

Main Office, 1012, 1014, 1016, 1018 Filbert St., Philadelphia, Pa.

WM. W. GOODWIN, Prest.

E. STEIN, Sec.

S. LEWIS JONES, Asst. Sec.

A. J. DOTY, Supt.

The utility and convenience of the Gas Engine being no longer an open question, it only remains now for intending purchasers to select the BEST. We claim for the CLERK GAS ENGINE that it is equal to any other manufactured as regards steadiness in running, simplicity, and ease of keeping in repair, and that it gives the greatest amount of power for the least money (both in first cost and expense of running) of any engine made. In support of this claim we refer to the test of the Gas Engines made under the direction of the American Institute of New York, in December, 1885, and heretofore published in these columns. These engines are especially adapted for continuous running under heavy loads, and we can refer to Engines which have run 22 hours a day for months at a time

Made in Sizes of 5 10 15 20, and 25 Horse Power. All Engines Guaranteed for One Year.

GAS STOVES.

GAS METERS.

GAS STOVES.

THE AMERICAN METER CO.,

MANUFACTURERS OF

GAS METERS, Station Meters,

METER PROVERS, PHOTOMETERS,

PRESSURE GAUGES OF ALL KINDS,

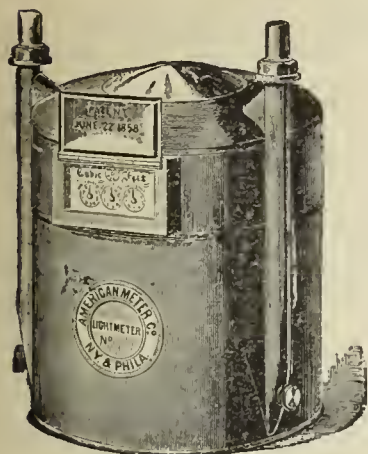

Standard 3 Diaphragm Dry Meter

AND

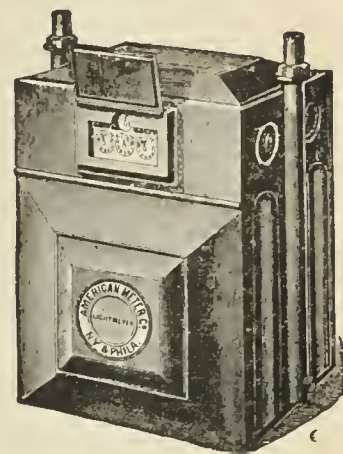

Standard 2 Diaphragm Dry Meter.

Apparatus for Testing the Quantity and Quality of Gases.

GAS STOVES FOR HEATING AND COOKING

Sole Agents in the United States for

Verity's Patent Gas Fires.

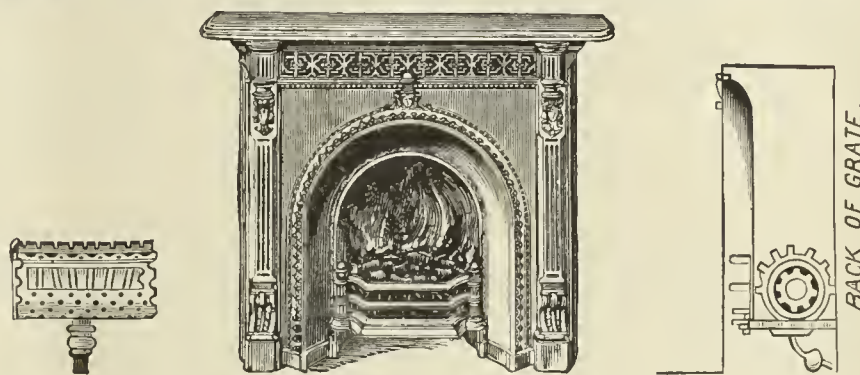

Circulars and Price Lists on Application.

MANUFACTORIES,

508 to 514 West Twenty-second St., N. Y.

Arch and Twenty-second St., Phila.

Nos. 244 & 246 North Wells Street, Chicago, Ill.

AGENCIES,

No. 177 Elm Street, Cincinnati, Ohio.

No. 222 Sutter Street, San Francisco, Cal

No. 810 North Second Street, St. Louis, Mo.

GAS STOVE SHOW ROOMS, No 242 Sixth Avenue, New York City.

RETORTS AND FIRE BRICK.

J. H. GAUTIER & CO..
CORNER OF
GREENE AND ESSEX STREETS,
JERSEY CITY, N. J.

MANUFACTURERS OF
**Clay Gas Retorts,
Gas House Tiles,
Fire Bricks, Etc. Etc.**
Ground Clay, Fire Brick and
Fire Sand in Barrels,

J. H. GAUTIER. C. E. GREGORY. C. E. GAUTIER.

BROOKLYN
Clay Retort & Fire Brick Works,
(EDWARD D. WHITE & CO.)
Manufacturers of Clay Retorts, Fire Brick,
Gas House and other Tile.
VAN DYKE, ELIZABETH, RICHARDS & PARTITION STS.
Office, 88 Van Dyke St., Brooklyn, N. Y.

RETORTS AND FIRE BRICK.

LACLEDE FIRE BRICK MFG. CO.,
MANUFACTURERS OF

Fire Brick, Gas Retorts,
AND
ST. LOUIS STANDARD SEWER PIPE.
Blast Furnace and Cupola Linings, every description of Fire
Clay Material, Fire Clay Flue Linings, Chimney Tops
Dry Milled and Crude Fire Clays, etc.
OFFICE AND DEPOT
901, 903, and 905 Pine Street,
ST. LOUIS, MO.

ESTABLISHED IN 1845.

B. KREISCHER & SONS,
OFFICE FOOT OF HOUSTON ST., E. R., N. Y.

Gas Retorts,
TILES, FIRE BRICK.
AND EVERYTHING IN THE FIRE CLAY LINE.

RETORTS AND FIRE BRICK.

MANHATTAN
FIRE BRICK & ENAMELLED CLAY
RETORT WORKS
ADAM WEBER.

CLAY GAS RETORTS
AND RETORT SETTINGS
FIRE BRICKS, TILES, ETC.,
Office and Works, 15th Street and Avenue C., N. Y.



Works,
LOCKPORT STATION, PA.

—ESTABLISHED 1864.—

JAMES GARDNER, JR.,

Office, Rooms 19 & 20, Lewis Block,
PITTSBURGH, PA, P. O. Box 373.

Successor to WILLIAM GARDNER & SON.

Fire Clay Goods for Gas Works.

H. A. NORTON, No. 4 CENTRAL STREET, BOSTON, MASS., Agent for the New England States.

GEO. C. HICKS, Presl. **CHICAGO** CHAS. A. REED, Sec. & Treas.

Retort and Fire Brick Co.,
MANUFACTURERS OF
Fire Clay Goods of all Kinds,
AND BEST QUALITY ONLY.
Regenerative Furnaces & Water Gas Goods.
45th St., Clark to La Salle, Chicago.

GEROULD'S IMPROVED RETORT CEMENT.
A Cement for patching retorts, putting on mouthpieces, and
making up all bench-work joints. This Cement is mixed ready
or use. Economic and thorough in its work. Fully warranted
o stick. For recommendations and price list address
C. L. GEROULD & CO.,
5 & 7 Skillman St., Brooklyn, N. Y.
Western Agent, H. T. GEROULD, Mendota, Ill.

Parker-Russell
Mining and Mfg. Co.,

CITY OFFICE: { Mermod-Jaccard Bldg., Rooms 307 & 308,
Broadway and Locust Street, St. Louis, Mo.

PROPRIETORS OF THE

OAKHILL GAS RETORT & FIRE BRICK W'KS

Our immense establishment is now employed almost entirely in
the manufacture of materials for

GAS COMPANIES.

We have studied and perfected three important points. Our re-
torts are made to stand changes of temperature, the strongest
heats of the furnace, and the abrasion of feeding and emptying.

We furnish and build Half-Depth or Full
REGENERATOR FURNACES
of different kinds and most approved styles.

Correspondence solicited.

THOS. SMITH, Prest. AUGUST LAMBLA, Vice-Prest. & Supt.

BALTIMORE
RETORT & FIRE BRICK CO.

MANUFACTORY AT

LOCUST POINT, BALTIMORE, MD.

Clay Retorts, Blocks & Tiles,
FIRE BRICK, FIRE CLAY,
AND FIRE CEMENT.

Red and Buff Ornamental Tiles and Chim-
ney Tops. Drain and Sewer Pipe (from
2 to 30 inches). Baker Oven Tiles
12x12x2 and 10x10x2.

WALDO BROS., 88 WATER ST., BOSTON, MASS
Sole Agents the New England States.

1889 DIRECTORY 1889

OF THE GAS LIGHT COMPANIES of the UNITED STATES & CANADA.

Price, \$3.00.

A. M. CALLENDER & CO., No. 42 Pine Street, N. Y. City.

HENRY MAURER & SON,
 (ESTABLISHED 1856.)
EXCELSIOR FIRE BRICK & CLAY
RETORT WORKS
 WORKS, Perth Amboy, N. J.
 OFFICE, 418 to 422 East 23d St., N. Y.
Clay Gas Retorts,
BENCH SETTINGS,
 Fire Brick, Tiles, Etc.

FLEMMING'S
Generator-Gas Furnace

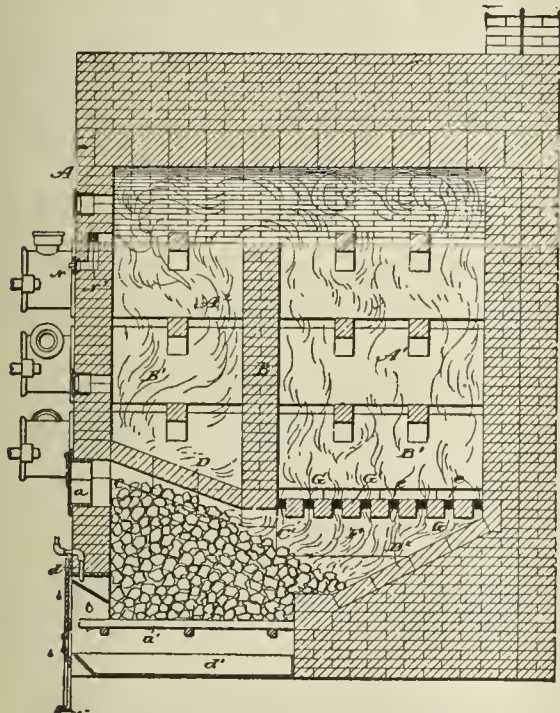

Materials furnished and Benches erected by

J. H. GAUTIER & CO., - Jersey City, N. J.

Address as above, or **D. D. FLEMMING, Jersey City, N. J.**

FRED. BREDEL,
 CONTRACTOR FOR THE COMPLETE
Erection and Equipment of Gas Works.
 SOLE PROPRIETOR OF THE
KLOENNE PATENTS
 FOR NORTH AMERICA.

REGENERATIVE FURNACES.

(900 Retorts are now fired in America by the Kloenne-Bredel System.)

SELF-SEALING MOUTHPIECES.

(Over 800 Now in Use.)

Standard Condensers. Washer-Scrubbers.

TAR WASHERS FOR WATER GAS PLANTS.

(In use in the works of the Chicago Gas Lt. Co.)

GASHOLDERS.

Bredel's Automatic Gas Governor.

Refers, by permission, to Mr. Eugene Vanderpool, Newark, N. J.; Mr. E. G. Cowdery, Milwaukee, Wis.; and Mr. Theo. Forstall, Chicago, Ills. For further information, address

FRED. BREDEL,
No. 208 East Seventeenth Street, N. Y. City.

HENRY PRATT & CO.,

BUILDERS OF THE

PRATT & RYAN WATER GAS GENERATORS,

Arranged to Use Either Crude Oil or Naphtha.

Condensers, Scrubbers, Purifiers, and all Apparatus for Coal or Water Gas.

IRON ROOFS, BOILERS, TANKS, ETC.

Orders and Correspondence Solicited.

Plans and Estimates Furnished for New Works or for the Alteration of Old Works.

Office and Works,
 869 to 875
 So. Halsted St.
 CHICAGO, ILL.

THE BRENNER SELF-SEALING RETORT DOOR.

Simple, Strong, and Durable.

CLOSES ABSOLUTELY TIGHT & IS LOCKED BY A CAM LEVER. ALL NECESSARY ADJUSTMENT FOR WEAR PROVIDED.

BUILT BY

SMITH & SAYRE MFG. CO.,

No. 245 Broadway, - - - New York City.

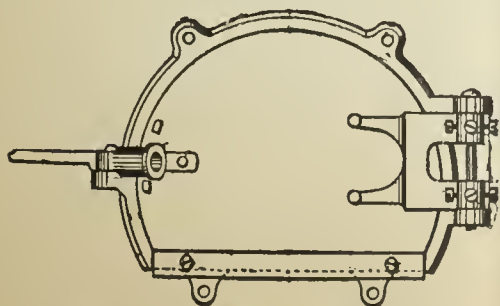

Brenner Self-Sealing Retort Door.

WILLIAM B. LUNDIE, Superintendent of the 42d Street Station of the Consolidated Gas Company, of New York, writes, under date of Jan. 4, 1889:

"We have 320 Brenner Self-Sealing Lids in use at this Station, built by the Smith & Sayre Mfg. Co. They require very little attention, and are the best of the kind that I have seen, giving entire satisfaction."

GAS AND WATER PIPES.

GAS AND WATER PIPES.

ENGINEERS.

SAM'L R. SHIPLEY, Pres.
HENRY B. CHEW, Tre

JAS. P. MICHELLON, Sec.
WM. SEXTON, Supt.

GLOUCESTER IRON WORKS,
GLOUCESTER CITY, N. J.



Cast Iron Gas & Water Pipes, Stop Valves, Fire Hydrants, Gasholders, &c.
Office, Rooms 61 and 63 Bullitt Building, 131 S. 4th St., Phila., Pa.

WARREN FOUNDRY AND MACHINE CO.,

Established 1856. Works at Phillipsburgh, N. J.

New York Office, 160 Broadway.

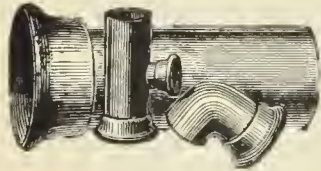

CAST IRON WATER AND GAS PIPE,

FROM TWO TO FORTY-EIGHT INCHES DIAMETER. ALSO, ALL SIZES OF

Flange Pipe for Sugar House and Mine Work. Branches, Bends, Retorts, etc., etc.

DENNIS LONG & COMPANY,

LOUISVILLE, KY.,



Manufacture Exclusively

CAST IRON GAS & WATER PIPE & SPECIAL CASTINGS
OF ALL SIZES.

King's Treatise on Coal Gas.

A standard text-book for the Engineers and Managers of Gas Works, and for all who are concerned or take an interest in the manufacture and distribution of Coal Gas, and in the utilization of the Secondary Products resulting therefrom; treating also of the Gas Engine, and of Gas Cooking and Heating Appliances.

In 3 Vols. Price per Vol., \$10. Sold either by Volume or in Sets.

A M. CALLENDER & CO., 42 Pine St., N. Y.

P. D. WANNER, Chairman. A. H. MELLERT, Mangr. of Wks.
R. B. KINSEY, Secretary. F. A. KNOPP, Treasurer.

MELLERT FOUNDRY & MACHINE CO. Ltd.
and **READING FOUNDRY CO., Ltd.,**
Reading, Pa.



Specials—Flange Pipe, Valves and Hydrants
Lamp Posts, Retorts, etc.

General Foundry and Machine Work.
JOHN FOX, Selling Agent, 160 Broadway, N. Y.

THE OHIO PIPE COMPANY,

MANUFACTURERS OF

Cast Iron Gas & Water Pipe,
BRANCH AND SPECIAL CASTINGS.

Gas-House Bench Castings, Hydraulics, Lamp Posts, Flange Pipe
and Specials, Architectural Castings, Building Columns,
Joists, Cellar Grates, Sash Weights, etc.

GENERAL FOUNDERS AND MACHINISTS.
Columbus, Ohio.

M. J. DRUMMOND,



SPECIAL CASTINGS AND LAMP POSTS.
Office, Corbin Building, 192 Broadway, N. Y.

EMAUS PIPE FOUNDRY.

DONALDSON IRON COMPANY. EMAUS, PA.



MANUFACTURERS OF

CAST IRON PIPE AND SPECIAL CASTINGS
FOR WATER AND GAS.

JOS. R. THOMAS,

No. 42 Pine Street, N. Y. City.

CONSULTING AND CONSTRUCTING
Gas Engineer and Contractor.

PLANS, SPECIFICATIONS, AND ESTIMATES
FURNISHED.

Contracts taken for all Appliances
required at a Gas Works,
Either for New Works or Extensions to Old Plants.

WM. MOONEY

(Successor to WM. FARMER)

No. 94 Liberty St., N. Y. City.

GAS ENGINEER AND CONTRACTOR FOR THE ERECTION
OF GAS WORKS, OR APPARATUS OF ANY
CAPACITY.

Plans and Specifications Furnished.

WM. GARDNER,
Gas Engineer,

Lewis Block, Room 20, Pittsburgh, Pa.

Those who intend to make alterations in existing gas plants, or
who contemplate the erection of new works, will find it to their
interest to open correspondence with the above. Plans and
estimates furnished.

BARTLETT, HAYWARD & CO.

Baltimore, Md.

Triple Double, & Single-Lift
GASHOLDERS.

Iron Holder Tanks.

ROOF FRAMES.

Cirders.

BEAMS.

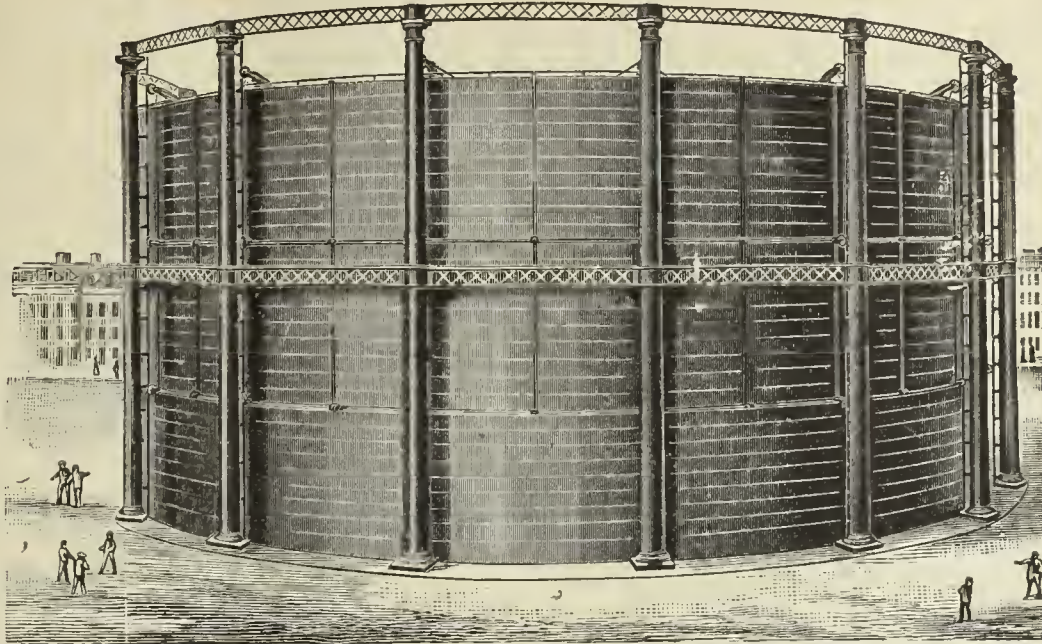

PURIFIERS.

CONDENSERS.

Scrubbers.

BENCH CASTINGS.

OIL STORAGE TANKS.

Boilers.

The Wilkinson Water Gas Process.

THIRTY-CANDLE, NON-CONDENSABLE, FIXED GAS. THE MOST SUCCESSFUL GAS PROCESS IN OPERATION.

Munich Regenerative Furnace, System Drs. Schilling & Bunte.

HAZELTON BOILERS.

Gas Works Designed and Constructed.

Pascal Iron Works. ESTABLISHED 1821. Delaware Iron Works.

MORRIS, TASKER & CO.,

INCORPORATED.

OFFICE, 224 SOUTH THIRD STREET, - - PHILADELPHIA, PA.

CONTRACTORS, BUILDERS, AND MANUFACTURERS OF

Gas, Water & Sugar Works

Bench Castings.

Condensers.

Scrubbers.

Purifiers.

Hyd. Carriages.

Iron Floors,

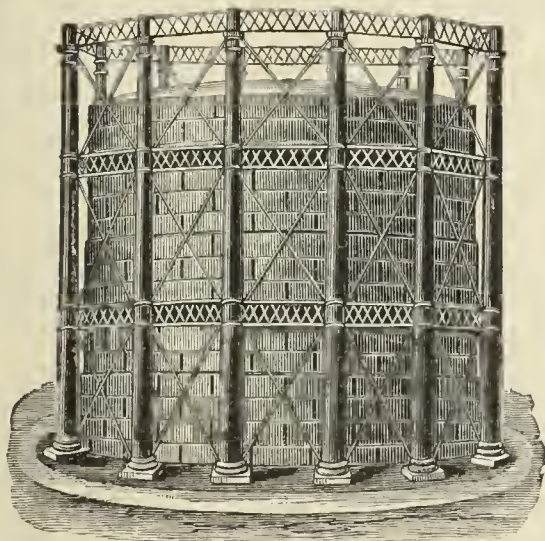

Iron Roofs.

Street Stops,

Valves, etc.

Stand-Pipes.

Water & Oil

Tanks, all Sizes.

Single, Double, and Triple-Lift Gas Holders.

SELF-SEALING RETORT LIDS. STAMPED STEEL RETORT LIDS.

Locomotive Water Columns, Filters, etc. Boiler Tubes, Wrought Iron Pipe & Fittings

Plans, Specifications and Estimates for all kinds of Machinery furnished on application.

Foundries & Works,
MILLVILLE, FLORENCE,
and CAMDEN, N. J.

R. D. WOOD & CO.,

Engineers,
Iron Founders,
and
Machinists.

400 Chestnut St., PHILADELPHIA, PA.

MANUFACTURERS OF

CAST IRON PIPE,

Gas Holders,

SINGLE, DOUBLE, AND TRIPLE LIFTS, WITH
OR WITHOUT WROUGHT IRON
OR STEEL TANKS.

PURIFIERS, CONDENSERS.

Scrubbers.

BENCH WORK.

Iron Floors and Roofs, Plate Girders.

Heavy Loam Castings.

HYDRAULIC WORK.

Lamp Posts, Valves, Etc.

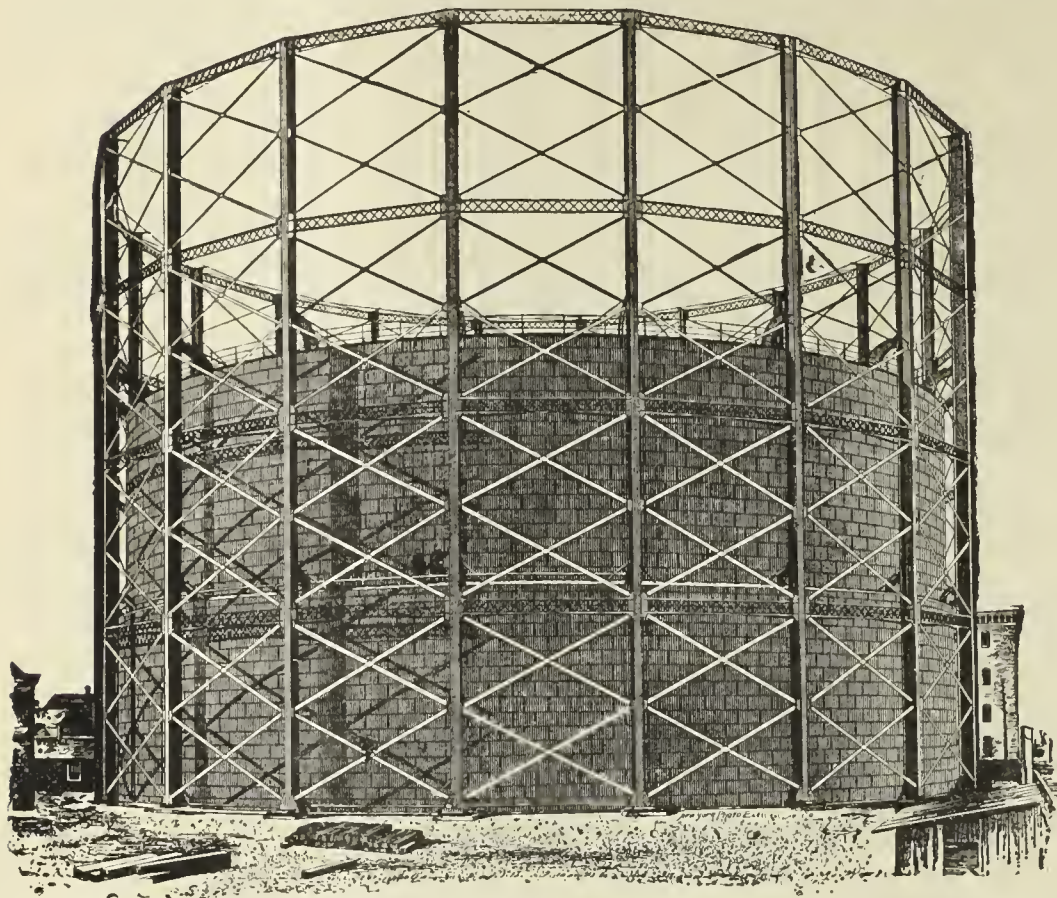

ROOTS'

GAS AND BYE-PASS VALVES.

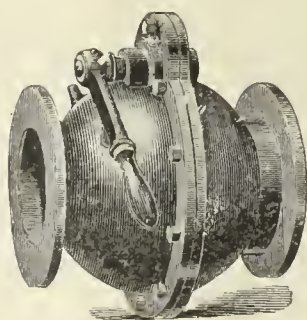

GAS VALVE

Quick Acting,
Simple,
Efficient, Durable.

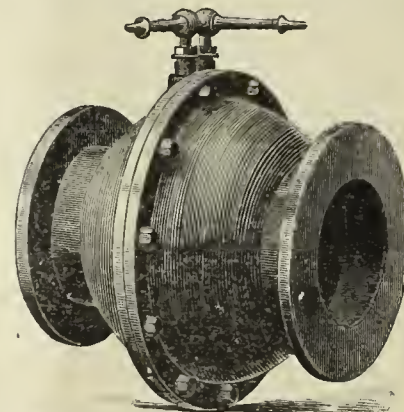

BYE-PASS VALVE.

Automatic Action,
Reliable,
Simple, Durable.

Thousands now in use and giving perfect satisfaction. Write for Catalogue and Prices.

THE P. H. & F. M. ROOTS CO., - - CONNERSVILLE, IND.

S. S. TOWNSEND, Gen. Agt., 22 Cortlandt St., N. Y.

COOKE & CO., Selling Agts., 22 Cortlandt St., N. Y.

GAS WORKS APPARATUS AND CONSTRUCTION.

GAS WORKS APPARATUS AND CONSTRUCTION.

JAMES R. FLOYD & SONS,

(SUCCESSORS TO HERRING & FLOYD)

Oregon Iron Works,

W. 20th & 21st Sts., bet. 10th & 11th Avs.,

NEW YORK CITY.

Engineers and Contractors

FOR THE

CONSTRUCTION OF GAS WORKS.

MANUFACTURERS OF

All Kinds of Castings and General Ironwork

FOR

GAS APPARATUS.

Bench Castings, Regenerative and Half Regenerative Furnace Castings.

Condensers, Scrubbers, Purifiers, Street Drips and Connections,

Valves,

Hydraulic Hoisting Purifier Carriage, Self-Sealing Retort Lids, Improved Valve Stand and Indicator, Seller's Cement.

Plans, Specifications, and Estimates furnished for Construction of New or Alteration of Old Works.

CONTINENTAL IRON WORKS.

THOS. F. ROWLAND, Prest.

WARREN E. HILL and CHAS. H. CORBETT, V-Prests.

THOS. F. ROWLAND, JR., Sec. & Tr

P. O. Station G., BROOKLYN, N. Y.

ENGINEERS AND MANUFACTURERS OF

Gas Holders

CONDENSERS, SCRUBBERS, VALVES,

PURIFIERS, SELF-SEALING RETORT LIDS

Hydraulic Mains,

And all other articles connected with the manufacture and distribution of Gas.

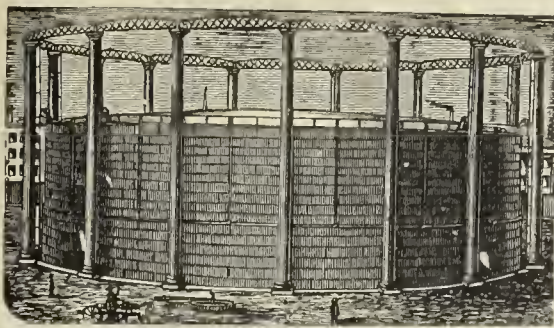

H. RANSHAW, Prest. & Mangr.

WM. STACEY, Vice-Prest.

T. H. BIRCH, Asst. Mangr.

R. J. TARVIN, Sec. & Treas.

STACEY MFG. CO.,

MANUFACTURERS OF

Single and Telescopic Gasholders,

IRON ROOFS, BRIDGES, LAMP POSTS,

Water and Oil Tanks, Coal Elevator Cars,

COKE CRUSHERS, BENCH CASTINGS,

And all kinds of Wrought and Cast Iron Work used in the erection of Coal and Oil Gas Works Rolling Mill Machinery and Heavy Castings a Specialty.

Foundry:

33, 35, 37 & 39 Mill Street.

Wrought Iron Works:

16, 18, 20, 22, 24 & 26 Ramsey Street:

Cincinnati, Ohio.

Bouton Foundry Co.,

FOUNDERS AND MACHINISTS,

CHICAGO, ILL.

Gas Works Apparatus,

PURIFIERS, CONDENSERS,

Bench Work

SPECIALS, LAMP POSTS,

SCRUBBERS,

Iron Roofs and Floors.

Plans and Estimates furnished for new works or extensions of old works.

1842. DEILY & FOWLER, 1889.

Laurel Iron Works.

Address, No. 39 Laurel Street, Philadelphia, Pa.

BUILDERS OF

GASHOLDERS,

Single and Telescopic.

Holdings Built 1884 to 1888, Inclusive:

- | | | | | |
|----------------------------|-----------------------------|---------------------------|--------------------------|------------------------|
| Newport, R. I. | Long Island City, N. Y. | Port Chester, N. Y. | Malden, Mass. | West Chester, Pa. (2d) |
| Portland, Oregon. | Macon, Ga. | New Rochelle, N. Y. | Paducah, Ky. | Lancaster, Pa. (3d) |
| Allegheny, Pa. (2d.) | York, Pa. | Salem, N. J. (3d) | Norwich, Conn. | Tacony, Pa. (two) |
| Atlanta, Ga. (2d.) | Chester, Pa. | Omaha, Neb. (2d) | Seattle, W. T. | Mount Vernon, N. Y. |
| N.Y. City (Central Gas Co) | Hazleton, Pa. (2d.) | Lynn, Mass. (2d) | San Diego, Cal. | Binghamton, N. Y. |
| Lynchburg, Va. (2d.) | State Island, N. Y. | Little Rock, Ark. | Northern Gas Lt. Co., of | Concord, N. H. |
| Saylesville, R. I. | Saugerties, N. Y. | Irvington, N. Y. | New York, N. Y. | Dover, Del. (2d) |
| Rondout, N. Y. | Clinton, Mass. (Lan. Mills) | South Boston, Mass. | Westerly, R. I. | Calais, Me. |
| Atlantic City, N. J. | Chattanooga, Tenn. | Rye, N. Y. (2) | Willimantic, Conn | New Loudon, Conn. (3d) |
| Augusta, Ga. | Galveston, Texas. (3d.) | Woodstock, Ont. | Montclair, N. J. | West Chester, N. Y. |
| Waltham, Mass. (2) | Omaha, Neb. | Malden, Mass. | Attleboro, Mass. | Bay Shore, L. I. |
| Mahanoy City, Pa. | Fort Plain, N. Y. | Staten Island, N. Y. (2d) | Santa Cruz, Cal. | Washington, D. C. |
| New Castle, Pa. | Brunswick, Ga. | Woodstock, Ont. | Erie, Pa. (2d) | |

SMITH & SAYRE MFG. COMPANY,

G. G. PORTER, Prest.

245 Broadway, N. Y.

CHAS. W. ISBELL, Sec'y.

Machinery & Apparatus for Gas Works

Drawings, Plans, and Estimates Furnished for the Improvement, Extension, or Alteration of Gas Works, or for the Construction of New Works.

Mackenzie's Patent Rotary and Steam Jet Gas Exhausters, Governors, Compensators, Condensers, Washers, Scrubbers. Isbell's Patent Automatic Street Pressure Governor, Gas and Water Valves, Hydraulic Main Dip Regulator, Bench Castings, etc. Purifying Boxes and "Standard" Scrubbers, Isbell's Patent Self-Sealing Retort Doors.

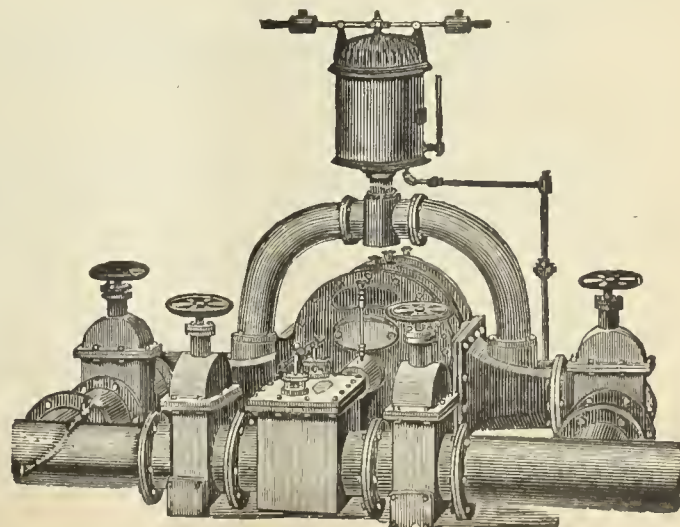

GAS COALS.

CANNEL COALS.

GAS ENRICHERS.

JAMES D. PERKINS. **PERKINS & CO.,** F. SEAVERNES.
 228 & 229 Produce Exchange, New York.
 Cable Address, "PERKINS, NEW YORK." Post Office Box 3695, New York.

GENERAL SALES AGENTS FOR

The Youghioghenny River Coal Company's

OCEAN MINE YOUGHIOGHENY GAS COAL.

HON. W. L. SCOTT, Prest. M. H. TAYLOR, Vice-Prest.

This Colliery is located at SCOTT HAVEN, PA., in the center of the Youghioghenny Gas Coal District, and produces the ONLY RELIABLE YOUGHIOGHENY COAL for gas purposes. (See Map on p. 87 of this JOURNAL, Feb. 16, '85.)

POINTS OF SHIPMENT,

Locust Point, BALTIMORE. Pier No. 62, PHILADELPHIA.

Also, SOLE AGENTS for the

**BRECKENRIDGE CANNEL,
OF KENTUCKY.**

Within the past two years we have delivered this Cannel to over ONE HUNDRED COMPANIES IN THIRTY-THREE DIFFERENT STATES, and it is now in use in some of the large Gas Works

On the Continent and in South America,

where it successfully competes with the Australian Shale. It is the ONLY AMERICAN GAS CANNEL of sufficiently high grade to warrant EXPORTATION TO EUROPE AND SOUTH AMERICA, and it is the only economical substitute for OIL OR NAPHTHA. ONE GROSS TON will produce

10,000 Cubic Feet of 75 Candle Gas,	} equal to {	750,000 Candle Feet of Gas, and 26 Bushels of merchantable Coke weighing 900 Pounds
or 12,500 " " 60 " "		
or 15,000 " " 50 " "		

This is the ONLY GAS CANNEL that will produce a REALLY MERCHANTABLE COKE. It can be delivered in parcels of one carload or more to any point in the United States or Canada. Cargo shipments of any size required can be made from NEW YORK, PHILADELPHIA, BALTIMORE, or NEWPORT NEWS. Samples will be sent and particulars of price, etc., forwarded upon application to above address.

JAMES & WILLIAM WOOD,
Gas and Cannel Coal Contractors,

No. 40 St. Enoch Sq., Glasgow. No. 2 Talbot Court, London.

Proprietors of the BATHVILLE COLLIERIES (which produce the celebrated BOGHEAD CANNEL), Shields, Shieldmuir, Drumpeller, and other Collieries. This Firm offer

STANDARD CANNELS,

Unequaled as Gas Enrichers.

Also, WEST FAIRMONT GAS COAL, of W. Va.

Analyses, prices, and all further information furnished on application to

Agency for U. S., Room 93, Nos. 2 & 4 Stone St., N.Y. City.

The Standard Oil Company,

REFINERS OF

NAPHTHA AND GASOLINES.

ALSO MANUFACTURERS OF

A Special Grade of Naptha for Gas Companies

FOR ENRICHING COAL GAS.

Correspondence solicited.

No. 43 Euclid Avenue, Cleveland, Ohio.

To Gas Companies.

We make to order CAP BURNERS to burn any amount under a stated pressure. Send for samples.

Also, SERVICE CLEANERS, DRIP PUMPS, and STREET MAIN PROVING APPARATUS.

C. A. GEFROER,

248 N 5th Street, Phila., Pa.

COKE CRUSHERS.

Newburgh Orrel Coal and Coke Co.

MINERS AND SHIPPERS OF

STEAM, SMITHING, AND GAS COALS,
Foundry and Crushed Coke.

Home Office, 33 S. Gay Street, Baltimore, Md.

J. HARRY LEE, President.

CHAS. W. HAYS, Agent, No. 1 Broadway, N. Y.

Shipping Wharves, Locust Point, Baltimore.

The Despard Gas Coal Co.,

MINERS AND SHIPPERS OF

DESPARD GAS COAL,

AND MANUFACTURERS OF

COKE.

MINES, Clarksburg, Harrison Co., W. Va.

WHARVES, Locust Point, Baltimore, Md.

OFFICE, 225 E. German St., " "

ROUSSEL & HICKS, } AGENTS. } BANGS & HORTON,
71 Broadway, N. Y. } 60 Congress St., Boston.

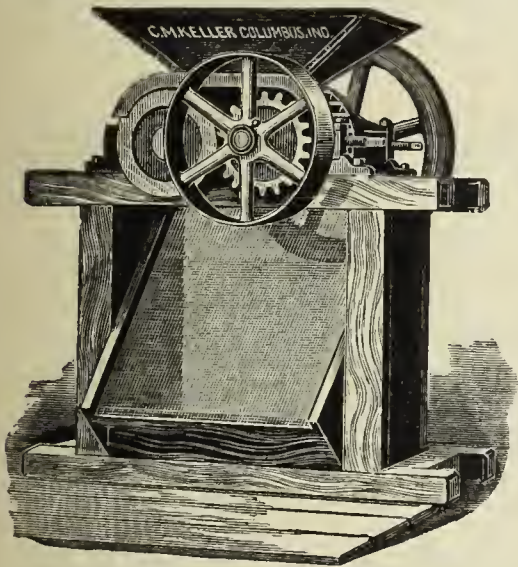

Keller's Adjustable Coke Crusher.

SIMPLE, STRONG, AND DURABLE.

C. M. Keller, Sec. & Supt. Gas Lt. & Coke Co. Columbus, Ind.

Correspondence Solicited.

King's Treatise on Coal Gas.

The most complete work on Coal Gas ever published.

Three Vols. Bound, \$30.

BOOKS.

DISTILLATION OF COAL TAR AND AMMONIACAL LIQUOR.

By GEORGE LUNGE. Price \$12.50.

A TREATISE ON THE COMPARATIVE COMMERCIAL VALUES OF GAS COALS AND CANNELS.

By DAVID A. GRAHAM. 8vo., Cloth. Price \$3.

Orders for these books may be sent to this office.

A. M. CALLENDER & CO.,

42 PINE ST., N. Y. CITY

GAS COALS.

GAS COALS.

THE PENN GAS COAL CO.

OFFER THEIR

Coal, Carefully Screened & Prepared for Gas Purposes.

Their Property is located in the Youghiogheny Coal Basin, near Irwin and Penn Stations on the Pennsylvania Railroad, and on the Youghiogheny River.

Principal Office:

209 SOUTH THIRD STREET, PHILA., PA.

Points of Shipment:

Pennsylvania Railroad Piers; Greenwich Wharves, Delaware River; Pier No. 1 (Lower Side), South Amboy, N. J.

Chesapeake & Ohio Railway Coal Agency,

FOR THE SALE OF THE

Superior Kanawha Gas Coals, Cannelton Cannel,
Also, SPLINT AND STEAM COALS

From the Kanawha and New River Regions, on the line of the Chesapeake & Ohio R'way.

C. B. ORCUTT, General Agent, - - No. 1 Broadway (Room 217) New York City.

FRANCIS H. JACKSON, Prest. EDMUND H. MCCULLOUGH, V.-Prest. CHAS. F. GODSHALL, Treas. H. C. ADAMS, Sec.

THE WESTMORELAND COAL CO.

Chartered 1854.

Mines situated on the Pennsylvania and the Baltimore and Ohio Railroads, in Westmoreland County, Penn.

POINTS OF SHIPMENT:

PHILADELPHIA, BALTIMORE, SOUTH AMBOY, N. J.,
WATKINS (SENECA LAKE), N. Y.

Since the commencement of operations by this Company its well-known Coal has been largely used by the Gas Companies of New England and the Middle States, and its character is established as having no superior in gas-giving qualities, and in freedom from sulphur and other impurities.

Principal Office, 224 South 3d St., Phila., Pa.

The American Gas Engineer and Superintendent's Handbook.

By WILLIAM MOONEY.

Consisting of Rules, Reference Tables, and Original Matter Pertaining to the Manufacture, Manipulation, and Distribution of Illuminating Gas.

350 Pages, Full Gilt Morocco. Price, by Mail, \$3.00.

A. M. CALLENDER & CO., 42 Pine St., N. Y.

GAS METERS.

GAS METERS.

GAS METERS.

JOHN J. GRIFFIN & CO.,

Gas Meter Manufacturers,

Philadelphia, New York
and Chicago,

Will Occupy this Space Hereafter.



Dry Gas Meters.

With 40 years' experience and the best facilities for manufacturing, is enabled to furnish reliable work and answer orders promptly.

NATHANIEL TUFTS,

No. 153 Franklin Street, Boston, Mass.,

MANUFACTURER OF

DRY GAS METERS.

Station Meters of any Capacity.

Test and Experimental Meters, Pressure Registers, Pressure Gauges,
Pressure and Vacuum Gauges.

METER PROVERS, PHOTOMETERS, STREET LANTERNS, ETC., ETC.

Patent Cluster Lanterns for Street Illumination.

HAROLD J. BELL.

BELL & JONES,

S. LEWIS JONES.

No. 12 North Ninth Street, Philadelphia, Pa. Works at Royersford, Pa.

MANUFACTURERS OF

GAS METERS, STATION AND EXPERIMENTAL METERS,

Meter Provers, Pressure Gauges, and All Other Gas Appliances in Our Line.

WE REPAIR ALL KINDS AND MAKES OF METERS, AND THE WORK GUARANTEED.

High Pressure Meters for Natural Gas, in Iron Cases, guaranteed to stand 300 lbs. Pressure.
Gas Cooking and Heating Stoves, Hot Plates, Cake Griddles, Waffle Bakers, Boiling
Stoves, Laundry and Tailors' Iron Heaters. Hotel and Cafe Ranges a Specialty.

Correspondence Solicited.

Estimates Furnished.

CHARLES E. DICKEY.

JAMES B. SMALLWOOD.

CHARLES H. DICKEY.

THE MARYLAND METER AND MANUFACTURING CO.

Established 1866.

BALTIMORE, North & Saratoga Sts.

CHICAGO, 197 Michigan Street.

NEW YORK, 766 Broadway.

BOSTON, 4 Central Street.

ST. LOUIS, 1115 Olive Street.

SAN FRANCISCO, 330 Pine Street.

CONSUMERS' & STATION METERS, PRESSURE GAUGES, Etc., Etc.

"Success" and "Perfect" Gas Stoves.

GAS METERS.

GAS METERS.

GAS METERS.

GEO. J. MCGOURKEY, Prest.

WM. H. MCFADDEN, Vice-Prest. (Phila.)

WM. N. MILSTED, Gen. Supt. and Treas. (New York).

WM. H. DOWN, Sec.

THE AMERICAN METER CO.

WET AND DRY GAS METERS.

PRESSURE REGISTERS.

METER PROVERS.

STATION METERS.

PRESSURE & VACUUM REGISTERS.

PORTABLE TEST METERS.

EXHAUSTER GOVERNORS.

PRESSURE & VACUUM GAUGES.

EXPERIMENTAL METERS.

DRY CENTER VALVES.

CRESSON GAS REGULATORS.

AMMONIA TEST METERS.

GOVERNORS FOR GAS WORKS.

MARSLAND WATER METERS.

BAR & JET PHOTOMETERS.

Manufactories:

512 West 22d St., N. Y.
Arch & 22d Sts., Phila.

GAS STOVES.

SUGG'S "STANDARD" ARGAND BURNERS,
SUGG'S ILLUMINATING POWER METER,
Wet Meters, with Lizar's "Invariable Measuring" Drum.

Agencies:

177 Elm Street, Cincinnati.
244 & 246 N. Wells Street, Chicago.
510 North Second Street, St. Louis.
222 Sutter Street, San Francisco.

HELME & McILHENNY,

(Established 1848.)

CAS METER MANUFACTURERS,

Nos. 1339 to 1349 Cherry Street, Philadelphia, Pa.,

WET AND DRY GAS METERS, STATION METERS, EXPERIMENTAL METERS, METER PROVERS,

Center Seals, Pressure Registers, Governors, Indicators, Photometers, and all other kinds of Apparatus for use in Gas Works.

FOULIS' PATENT STATION AND DISTRICT GOVERNORS.

REPAIRING DEPARTMENT.—We employ a special force of skilled workmen repairing meters of all makers.

WM WALLACE GOODWIN, Prest. and Treas.

WM H. MERRICK, Vice-Prest.

S. L. JONES, Sec.

S. V. MERRICK, Supt.

THE GOODWIN GAS STOVE AND METER CO.,

Successors to W. W. GOODWIN & CO.

1012, 1014 and 1016 Filbert St., Phila., Pa.

142 Chambers St., New York City.

76 Dearborn, St., Chicago, Ills.

WALDO BROTHERS, Agents, 88 Water Streets, Boston, Mass.

MANUFACTURERS OF

DRY AND WET GAS METERS,

Station Meters (square, cylindrical, or in staves), Glazed Meters, King's and Sugg's Experimental Meters, Lamp Post Meters, etc., etc. Meter Provers (sizes 2, 5, and 10 feet), Pressure Gauges of all kinds, Pressure Registers, Pressure and Vacuum Registers, Pressure Indicators (sizes 4, 6, and 9 inch), King's Pressure and Vacuum Gauges, Dry and Wet Center Seals, Dry and Wet Governors, Exhauster Governors, Photometers of all descriptions. Letheby's Sulphur and Ammonia Test Apparatus complete. Also, Testing and Chemical Apparatus of all kinds, and of the most perfect description, for all purposes relating to Gas.

Manufacturers of the "SUN DIAL" GAS STOVES, for Cooking and Heating.

Goodwin's Improved Lowe's Jet Photometer.

Agents for Bray's Patent Gas Burners and Lanterns.

Special attention to Repairs of Meters and all Apparatus connected with the business. All work guaranteed first-class in every particular. Orders filled promptly.

G. B. EDWARDS, Manager, New York.

S. S. STRATTON, Manager, Chicago.

D. McDONALD & CO.,

GAS METER MANUFACTURERS.

(Established 1854.)

51 Lancaster St., Albany, N. Y.

34 & 36 West Monroe St., Chicago, Ill.

STATION METERS, EXPERIMENTAL METERS, METER PROVERS, PRESSURE & VACUUM REGISTERS, PRESSURE GAUGES, ETC

Also STAR GAS STOVES, RANGES, and HEATING STOVES.

We use only the very best materials, and employ the most skilled labor, and by our long experience (32 years) and personal supervision of every detail, we feel justified in assuring the public that our goods will give perfect satisfaction. Every Meter emanating from our establishment will bear the State Inspector's stamp, and will be fully warranted by us. Our Annual and Calendar will be sent to Gas Companies upon application.

250 & 252

Pearl Street,

JOHN HILLEN'S BROOKLYN GAS METER WORKS.

BROOKLYN,

N. Y.

MANUFACTURER OF

IMPROVED GAS METERS

REPAIRING OF METERS (of all makers) a specialty. All defective working parts are replaced without extra charge. A guarantee is given with all work sent from this shop. Write for Price List.

GAS STOVES.

GAS STOVES.

GAS STOVES.

THE GOODWIN GAS STOVE AND METER CO.,

1012-18 Filbert St., Phila., 142 Chambers St., N. Y., 76 Dearborn St., Chicago.

Agents, WALDO BROTHERS, 88 Water Street, Boston.

WM. W. GOODWIN, Pres. and Treas.
W. H. MERRICK, Vice-Pres.
S. LEWIS JONES, Sec.

SAMUEL V. MERRICK, Supt.
G. B. EDWARDS, Mang'r, N. Y.
S. S. STRATTON, Mang'r, Chicago.

SOLE MANUFACTURERS OF THE

"SUN DIAL" GAS STOVES,

The Most Economical, Efficient, and Durable Gas Stove Made.

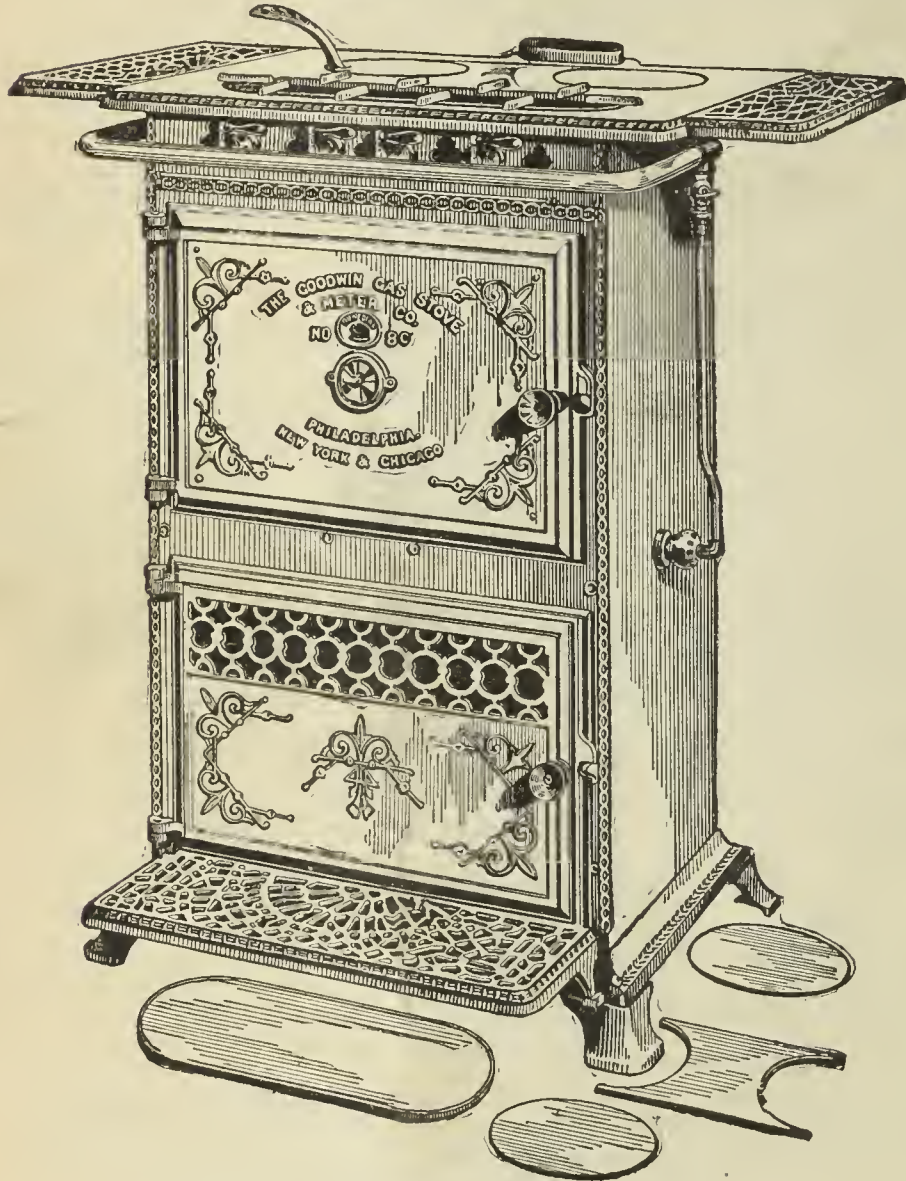

GAS COOKING STOVE, No. 8 C.

SIZE.

Stove.	Oven.	Roaster.	Top.	Length over Extension Shelves,
37 in. high. 20 in. wide.	12 in. high. 17 1/2 in. wide. 12 in. deep.	12 in. high. 18 in. wide. 13 in. deep.	24 in. long. 21 in. wide.	36 in.

This Stove has four burners on top, and double oven burner. Consumption of gas with all burners in use, 42 feet per hour, at 1 inch pressure. The top is made in sections, so that a greater variety of cooking utensils may be used. By lifting out the covers and crosspieces and putting in a suitable forked ring, which is sent with each stove, a wash boiler or other large utensil may be set over two burners. Our No. 87 GRIDDLE also fits in the same position. The roasting oven is provided with a cast-iron door.

All Fittings are Nickel-Plated.

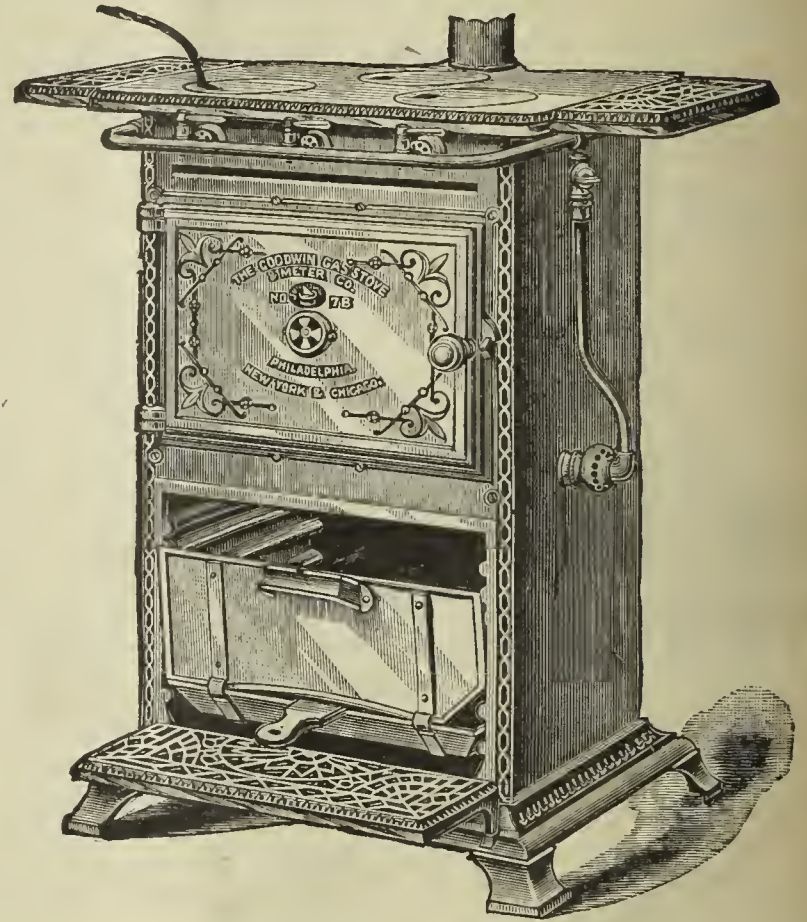

GAS COOKING STOVE, No. 7 B.

SIZE.

Stove.	Oven.	Roaster.	Top.	Length over Extension Shelves,
31 in. high. 17 in. wide.	9 1/2 in. high. 14 1/2 in. wide. 12 in. deep.	10 in. high. 15 in. wide. 13 in. deep.	21 in. long. 16 in. wide.	32 in.

This Stove has three boiling burners in the Top or Hot Plate, and one single oven burner.

This cut represents our New Style Cooking Stove. As will be seen, it has an ornamented cast-iron Base and Front, and extension shelves. The Oven Burner, which is atmospheric (unless otherwise ordered), is of an entirely new and improved pattern (patent). The ovens are of greater capacity than those of the old style. The Top, in conjunction with the Outlet Pipe, is designed to carry off all the products of combustion, if desired, but they are also supplied with a loose ring which converts it into an ordinary open top stove.

The consumption of this Stove is 35 cubic feet per hour at 1 inch pressure, with all Burners in use.

All Fittings are Nickel-Plated.

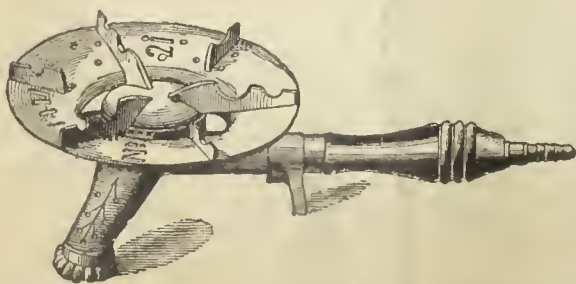

"RADIANT" BOILING STOVE, WITH REGENERATIVE BURNER.

Size, 6 1/2 inches diameter, 4 inches high. Consumption, 6 feet per hour at 1 in. pressure.

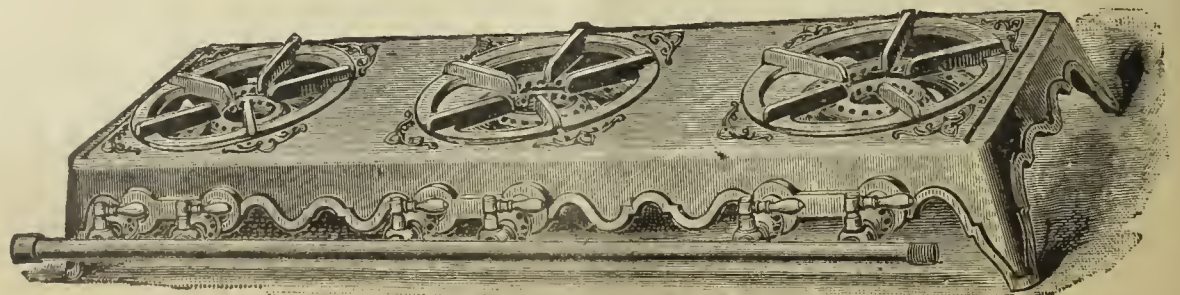

HOT PLATE, No. 111.

Size, 36 in. long, 12 in. wide, with three double burners, 6 taps. Consumption, with all burners in use, 36 cubic feet per hour, with 1 in. pressure. 1/2 in. supply pipe should be used where the pressure is 1 in. or over.

THE AMERICAN

GAS LIGHT JOURNAL

REDMAN & KENNY, N. Y.

PUBLISHING OFFICE NO. 42 PINE STREET

DEVOTED TO THE INTERESTS OF ILLUMINATION, VENTILATION, WATER SUPPLY AND DISTRIBUTION, & GENERAL SCIENCE.

VOLUME LII.—No. 6. }
Whole No. 766.

NEW YORK, MONDAY, FEBRUARY 10, 1890.

{ \$3 PER ANNUM,
IN ADVANCE.

A. M. CALLENDER & CO., Proprietors. C. E. SANDERSON, Manager.
JOS. R. THOMAS, C.E., Editor. T. J. CUNNINGHAM, Asst. Editor.

ENTERED AT THE POST OFFICE AT NEW YORK, N. Y.
AS SECOND CLASS MATTER.

CONTENTS.

An Asterisk (*) denotes an illustrated article.

OFFICIAL NOTICES—

Annual Meeting, New England Association of Gas Engineers.....	169
Ohio Gas Light Association.....	169

EDITORIALS—

Briefly Told.....	170
The New England's Twentieth Annual—Death of Dr. Lull, President of the Dubuque (Iowa) Key City Gas Company—Cheaper Gas for Peoria, Ills.—Commissioner Rowell and the Opposition Clique.	
*Note on Rankine's Treatment of Chimney Draft, by Prof. B. Webb	171
Lighting Cars.....	172
Mr. John West on Gas and Electricity.....	172
*The Dangers of Electric Lighting, by S. Z. de Ferranti and Francis Ince—Concluded from page 139.....	175
*Three Types of Electric Meters.....	176
The Financial Aspect of Natural Gas, by C. Harrison.....	177
Improvements on Coze's System.....	178

ITEMS OF INTEREST FROM VARIOUS LOCALITIES..... 179

Denied the Privilege—Western Gas and Fuel Company—Gas Company for Palmyra and Riverton, N. J.—Gas Company for Port Townsend, Wash.—Annual Meeting, Grand Rapids, Mich.—Regulating the Supply of Gas, Baltimore, Md.—Promotion of Mr. E. C. Jones—Ramsdell Bought the Coal—Hints from Belleville, Ills.—Sale of the Chillicothe (Mo.) Company—Chelsea, Mass., Wants its Electricity by Meter—Annual Meeting, Washington, O.—Annual Meeting, Centralia, Ills.—The Cost to Fort Worth of an Electric Plant—Injunction Denied at Burlington, Iowa—Sale of the Batavia (N. Y.) Plant—Annual Meeting, Hoosick Falls, N. Y.—Annual Meeting, San Francisco, Cal.—The Penn Coal Company in Court—Annual Meeting, Malden, Mass.—Proposed Opposition Company, Galesburg, Ills.—And Many Other Items.	
Influence of Temperature on Electric Tests.....	181
Luminous Paint.....	181
The Market for Gas Securities.....	182

[OFFICIAL NOTICE.]

New England Association of Gas Engineers.

SECRETARY'S OFFICE, BIRMINGHAM, CONN., Jan. 30, 1890.

The Twentieth Annual Meeting of the New England Association of Gas Engineers will be held at Young's Hotel, Boston, on Wednesday and Thursday, Feb. 19th and 20th. The meeting will be called to order by the President, Mr. Robert B. Taber, on the 19th inst., at 10 o'clock A.M. It can now be definitely stated that the following papers will be read sometime during the meeting:

- "Vaporization and Feed of Oil to Generator or Retort," by Dr. Robt. Amory, of Brookline, Mass.
- "Management of Small Gas and Electric Light Plant," by S. J. Fowler, of Westfield, Mass.
- "A Point or Two in Regard to Illuminants During Condensation and Purification," by George F. Goodno, of Dedham, Mass.
- "Notes on Revivification of Oxide," by Waldo A. Learned, of Newton, Mass.
- "Various Methods of Introducing Gas Stoves," by H. A. Norton, of Boston, Mass.

"A Few of the Advantages of Water Gas over Coal Gas for Small Works," by F. H. Parker, of Burlington, Vt.

"The Difference between Eastern and Western Methods in the Management of Gas Works," by E. G. Pratt, of Des Moines, Iowa.

"Why I Shall Make Water Gas," by A. B. Slater, of Providence, R. I.

"A Chapter of Don'ts," by W. H. Snow, of Holyoke, Mass.

"Some Notes Taken in a Small Gas Works," by Ralph Woodward, of Waltham, Mass.

"Problems Constantly before the Gas Manager," by E. H. Yorke, of Brockton, Mass.

In addition to the above there are partially promised several other papers. I think all the members who see this notice will agree that, judging by the above list, the coming meeting bids fair to be a greater success than any of the meetings which have been held in previous years. The topics are quite varied, and many of the subjects are among the most important that gas managers have to deal with at the present time.

The officers of the Association believe that no member of the Association, and no one connected with the active business management of any gas company in New England, can afford to be absent from this meeting. Persons eligible for membership and desiring to join the Association will please apply at once to the Secretary, who will forward them blank applications. Although the membership is large, there are still a good many persons connected with the gas business through New England who do not belong to the Association. It is hoped that all such persons will see fit to join at the coming meeting, and make the Association what it ought to be, truly representative of the gas interest in the New England States.

Invitations have been received to visit the Commercial Point and Bay State gas works in Boston, also the Loomis Fuel Gas plant at Waltham, which will add materially to the pleasure of the coming meeting.

CHARLES H. NETTLETON, Sec'y.

[OFFICIAL NOTICE.]

Ohio Gas Light Association.

OFFICE OF SECRETARY,
COLUMBUS, O., January 20, 1890.

To Members of the Ohio Gas Light Association:

Gentlemen—The Sixth Annual Meeting of this Association will be held at Toledo, O., on March 19 and 20, 1890.

This announcement is made thus early in order that all members may be reminded of the meeting in ample time to make their arrangements to be present. Every member is urged not only to attend this meeting, but also to interest himself in inducing others of his acquaintance who are eligible for membership, but who have not as yet joined the Association, to come to the meeting and become members.

It is not intended that as many papers as usual shall be presented at the forthcoming meeting, in order that more time than formerly may be had for the discussion of those that are read, and for such other matters and business as the members may desire to dwell upon.

Although the Secretary has for some time been engaged in the work

of soliciting papers for this meeting, he has not yet secured as many as should be had, notwithstanding fewer are desired than heretofore, and he therefore earnestly calls upon all members who can possibly do so to notify him immediately of their willingness to furnish papers.

It has been decided that an interesting and valuable feature of our meeting would be a "Question Box," in which members can place questions, which will be withdrawn and read to the meeting and answered and discussed by the members. Every member is requested to send to the Secretary at once any question or questions which he would like to have thus brought before the meeting.

Future circulars will announce further details concerning the meeting.

Respectfully, IRVIN BUTTERWORTH, Sec'y.

BRIEFLY TOLD.

THE NEW ENGLAND'S TWENTIETH ANNUAL.—In less than a fortnight the members of the New England Association shall have completed their twentieth annual reunion, and he might securely look for pardon who would exclaim that it did not seem as if 20 years had winged their flight from us into the silence of the past since the formation of the Association. Time, however, with even tread and careless of opinion, goes on untiringly. Take it all-in-all, the Association has much to congratulate itself in that time has dealt sparingly with its membership. Of course, it is said, and wisely, that exceptions serve to best prove a rule, and the assertion that time has dealt sparingly with the "Mother Association" can be proved by the record, even though the last exception is furnished in the death last month of Oliver Edwards Cushing, who served on the Board of Directors chosen at the first meeting in Boston, on Feb. 2, 1871. Changes there have been, and many, of course—Greenough, Sr., Hill, of Concord, Armington and Cabot relieved of active service; Cushing and Dwight dead—in fact of the first executives chosen those who still remain in harness are Neal, York and Moore, of Salem. Sturdy and strong and staunch as were the habits and morals of those who founded it, so has the Association progressed with the increase in its years of life and usefulness; and if we may judge from the matter which its Secretary, Mr. Nettleton, has been placing before our readers in the shape of current official notices it is bound to even make better history for itself than that in record of the past. A glance over the paper list will likely cause every member to make successful effort to be present when President Taber sounds the call to order, in order that its promise may be fully availed of. Many of the papers are to be by contributors who have not yet figured on the paper lists, and this of itself is convincing proof of the solidity of the Association. When each is willing to do his duty, the advancement of the common good is assured. In looking over the schedule one cannot but be impressed with the variety of subjects named, and the exceeding value to the fraternity that will arise from their presentation. Two papers in particular we look forward to with great interest, and while it may be as rash to attempt to justify a paper by its title as we are told it is to judge a book by its cover, we nevertheless hold that the contributions to be made by Mr. Goodno, of Dedham, and Mr. Pratt, of Des Moines, have been artfully named, that is, in respect to the facility of their titles for giving rise to anticipation. Aside from the regular list so far collated, it will be noted that Secretary Nettleton has the partial promise of other papers, but even should these fail to materialize the catalogue is sufficiently lengthy to insure plenty of thought food. We would urge upon those qualified to become members of the Association the advantage of so doing; and it goes without saying that the expense connected with the membership is sure to be more than one hundred times counterbalanced in the return that will be received.

DEATH OF DR. LULL, PRESIDENT OF THE DUBUQUE (IOWA) KEY CITY GAS COMPANY.—The fraternity, more particularly those engaged in the West, will join with us in regret over the death of Dr. John H. Lull (President of the Key City Gas Company), which sad event occurred on the morning of Wednesday, January 22d. Deceased had been complaining for some days, but did not attach any great importance to his symptoms. The latter, however, eventuated in an attack of pneumonia, which terminated fatally and with shocking suddenness. John H. Lull was born at Hartland, Vt., in June, 1828, and graduated from the Vermont Medical College, in the spring of 1850, as a duly qualified physician. Having looked the home field over carefully, he determined that preferment would come more quickly in a somewhat more extended field, and accordingly visited the West. In the fall of 1853 he settled in Dubuque, Iowa, in which city was spent the remainder of his busy life. No more devoted or capable citizen was sheltered by that city, and to its material advancement he gave freely of time, counsel and money. Pre-

ferring the greater latitude offered by commerce, deceased did not practice his profession in Dubuque, but turned his attention to business and its responsibilities. To name any of the important local enterprises started within the last 30 years is almost to mention an instance of Dr. Lull's connection with the material interests of Dubuque. Banks, manufacturing companies, public works—all claimed a share of his patronage and counsel. He was President of the Key City Gas Company for many years, and was a firm believer in the stability of gas lighting—a belief that largely added to his store of wealth. Respecting the personal character of the deceased, we are favored with the following from a correspondent:

"He was a man of remarkable breadth of mind and keen penetration. His executive ability was unusual, and it is a simple statement of fact to say that but for his foresight, optimism and energy many of the enterprises of which Dubuque boasts to-day, and which have greatly increased its population and enhanced its wealth, would not have materialized. He amassed means by prudence, and he so employed them as to make them a source of maintenance and blessing to others as well as to himself. No man could have devoted riches to a better use, and no man ever acquired them more justly. Dr. Lull was a diligent reader and profound thinker. His general knowledge was copious, and on certain historical, political and scientific subjects his knowledge of detail was astonishing. Endowed with strong reasoning powers, he drew sound conclusions, and conversation was with him a delight. It was impossible to exchange thoughts with him without being entertained and edified by his discourse. He had a catholic mind. It was expansive and well balanced, and a stranger to bigotry and prejudice; and like his mind, his heart was generous. No religious denomination ever appealed to him in behalf of charity in vain, and the deserving mendicant never left him empty-handed. He took pleasure in placing meritorious persons in the way of business success. His life was useful and honorable, and the loss of it is a loss to the community. To his family his demise is an almost insupportable affliction, but such poor consolation as heart-felt public sympathy can give them is theirs."

CHEAPER GAS FOR PEORIA, ILLS.—Almost every Western gas man is acquainted with Mr. Peter Coffey, Superintendent of the Peoria (Ills.) Gas Light and Coke Company, whose genial personality makes him welcome at all times. The Peoria man, however, is more than genial, in that he stands for what is "known out that way" as a "hustler." For many years he has been in charge of the manufacturing and distributing plants of the Peoria Company, and his command thereof has not been in vain. When to Coffey's ability and tact is coupled the fact that the executive management of the Company is of the progressive sort, one would naturally expect to hear that cheap gas is the rule at Peoria, nor would that presumption be wrongly held. Liberal as the former rates have been, the Superintendent has convinced his Directors that another cut could be made without prejudice in their business. In any event, an announcement has just been made that from and after the 1st prox. the following net rates are to prevail:

Monthly Consumption.	Net per M.
Less than 30,000 cubic feet.....	\$1.35
30,000 cubic feet and over.....	1.20
Gas for stove and power purposes.....	1.00

The only condition for obtaining a gas supply on the basis noted is that bills shall be paid on or before the 10th of the month. The figures speak most eloquently for Supt. Coffey's capability and his Company's tact, and while we are always on the lookout for opportunities of this kind as evidence of the advance that is being made in gas manufacture, we must admit that we were hardly prepared to announce that the next city to enjoy the dollar gas rate would be Peoria. Facts accomplished are those that lead to greater things, and it is in records of this nature that not only the stability but the continued triumph of the gas maker's craft can be proclaimed.

THE opposition to the reappointment of Mr. Rowell as a member of the Massachusetts Board of Gas and Electric Light Commissioners—his term of office expires within a few months—seems to be confined to a clique whose "practical politics" have hitherto been looked on with little favor by those who consider fitness for public service as the best recommendation that an aspirant for public office can present in support of his claim for recognition. While fully believing that Mr. Rowell's chances for reappointment are of the strongest sort, we nevertheless consider it our duty to say that it would be poor reward for faithfulness and fidelity did he fail of reappointment. His course in the Board, in common with that of his colleagues, has been of a nature well qualified to evoke admiration for its candor, impartiality and value.

MR. H. BOSTWICK has filed papers in the District Court (Hastings, Neb.) in which he prays for the appointment of a receiver for the Hastings Gas Light Company; also that the charter of the Company be revoked.

SOME days ago one of the Dominion Gas Inspectors paid a visit to the works of the Windsor (Ont.) Gas Company for the purpose of testing the purity of the gas supplied. He found an excess of sulphureted hydrogen, and complained of the same to Judge Bartlett, who summoned Manager Nash, of the Company, for an explanation. The latter having admitted that the Inspector was in the right, was fined \$12.85 under the statute.

Note on Rankine's Treatment of Chimney Draft.

By PROF. J. BURKITT WEBB.

Prof. Webb, in the last issue of the *Stevens Indicator*, having explained that his attention had been called to a criticism of Rankine and other noted authors, in a paper before the American Society of Mechanical Engineers, by Mr. Gale, in the discussion of which it was stated that a correct solution of the problem, if not two, is contained in "La Chaleur," by Peclet, remarks that on examination it appears that the paper is based upon an incorrect hypothesis, and that the only solution in "La Chaleur," which is claimed therein to be correct, gives the same result as does Rankine.

A brief comparison of the solutions will illustrate a point or two in mechanics and show Rankine's deep mechanical insight.

In Peclet's solution the pressure operating to produce the draft is found by subtracting the weight of a column of hot air, the height of the chimney, from that of an equal column of cold air.

The height of a column of air, which will give the pressure, is then calculated and the velocity reckoned as due to this height, in the same manner as the velocity of water issuing from a vessel is deduced from its height therein.

But Peclet hesitated between representing that pressure by a column of cold air and supposing it to produce the velocity with which the (cold) air enters the chimney, and representing it by a column of hot air, producing the velocity of the (hot) air issuing from the top of the same.

Mr. Hudelo, editing the last edition of Peclet, says that the mechanical theory of heat furnishes the means of deciding between the two formulas, and his analysis leads him to the choice of the column of hot air; the principles of thermodynamics, however, are not needed to show which formula should be used, the principles of mechanics known to Peclet being sufficient.

If the velocity be calculated by means of the column of cold air the total pressure available to produce the draft will be appropriated to the production of the velocity of the entering (cold) air, and nothing will remain to cause the increase of velocity which must accompany the increase of volume, when the air is heated by the fire.

Evidently the pressure at disposal should be supposed to be occupied in causing the final velocity of the (hot) air issuing from the top of the chimney, unless the fire can be supposed responsible for the increase of velocity as well as the increase of volume.

Now, it is a principle of mechanics that the internal forces in a free body or system of bodies cannot affect the motion of the center of gravity of the same, and, therefore, when an elementary mass of air is heated by its internal expansive forces, acting equally in all directions, can have no effect upon the velocity of the mass, which is controlled entirely by external forces.

While it is true that the fire is responsible for the increase of velocity, and, indeed, for the whole velocity, it causes it in an indirect manner; in fact, the fire simply keeps the clock wound up, so to speak, leaving it to run down under the control of gravity alone.

In refreshing contrast to the analysis in the last edition of Peclet, with its thermodynamic mistiness and approximations, is the clear and simple treatment in Rankine's "Steam Engine," some pages before thermodynamics is reached. While Peclet is referred to, the analysis is given in Rankine's own way. The question of head is disposed of in the following words:

"The formula* enables the velocity u to be computed when the head h is given;

"The head h is expressed in feet in height of a column of the hot gas in the chimney.

"The head may be produced in three ways:

- I. By the draft of a chimney.
- II. By a blast pipe.
- III. By a fan or other blowing machine.

"I. The head produced by the draft of a chimney is equivalent to the excess of the weight of a vertical column of cool air outside the chimney, and of the same height, above that of a vertical column, of equal base, of the hot gas within the chimney; and, when expressed in feet of hot gas, it is found by computing the weight of a column of the cool external air as high as the top of the chimney is above the grate and one foot square in the base, dividing by the weight of a cubic foot of the

$$* h = \frac{u^2}{2g} \left(1 + G + \frac{fl}{m} \right)$$

NOTE.—A review of the Hudelo-Peclet treatment may be expected at the next meeting of the American Society of Mechanical Engineers.

hot gas, for the height of an equivalent column of hot gas, and subtracting the former height from the latter."

Fig. 1 illustrates Rankine's conception. CD is the chimney whose draft is to be found. DE is a supposed extension of such height that the column of hot gas EC exerts the same pressure per square foot as the column of cold air AB .

If the outlet at F is closed the column of hot gas balances statically that of cold air, but if F is open the hot gas flows out under the head ED ; and if air is supplied at A the flow will be from A to F .

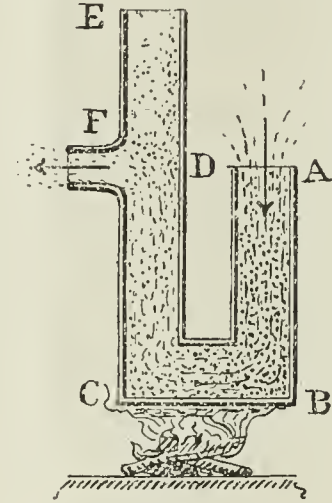

Fig. 1.

As the atmospheric pressure is the same at A and F it can be omitted entirely from the problem.

Peclet starts with the supposition of a fire outside to warm the air passing from B to C , so that the chimney contains air alone; Rankine supposes hot gas in the chimney, but his analysis applies equally to hot air.

A model could be made to illustrate this action in a tube of the same form, $ABCD E$. Let water be supplied at A , and let a jet of air be blown in at right angles to the current between B and C with sufficient force to mix thoroughly with the water. In AB there will now be solid water, and in CE a lighter mixture of water and air, which will rise to a height DE above the water level at A , when the mixture is properly proportioned, so that the issuing velocity at F will be that due to the head DE .

Thermodynamics may, however, be legitimately brought into the problem, for it must be evident that the density of the hot gas will not be the same at all parts of the chimney, and to get at the weight of the column some average density must be assumed, or the law of its variation must be obtained upon thermodynamic principles. The former method is, however, sufficiently accurate for all purposes.

Rankine knew that thermodynamics was not needed in the problem, and he appreciated fully the importance, in every problem, of seeing clearly the exact bearing of the different principles of mechanics upon the subject, and of making use of such as lead to the simplest and most reliable conclusions.

I am accustomed to use the following illustration of the independence of internal and external motions with my class in mechanics: Suppose a car (Fig. 2) to have mounted upon it a flywheel, on the shaft of which

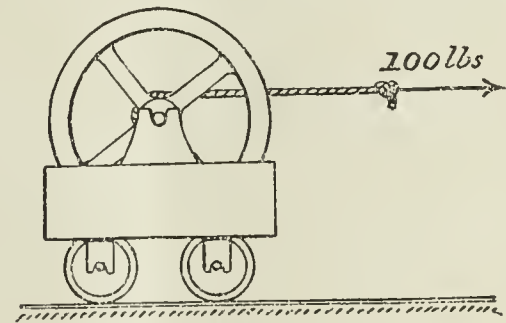

Fig. 2.

a rope is coiled. The rope is pulled in a direction parallel to the truck with a constant force of 100 pounds. What difference will it make in the motion along the track whether the flywheel is free to turn or whether it is blocked so that it cannot turn?

The principle of momentum solves the problem at once, for we have only to consider that the car and flywheel together constitute a body free to move horizontally, and that, so far as motion along the track is concerned, it is a matter of indifference whether there are also internal motions or not. The 100 pounds will produce a linear momentum of

100 each second (neglecting friction), whether the flywheel is free to turn or not; so that the motion of the car will be the same as though the rope were fast to the car itself.

If, on the other hand, the problem be to find out how much work the force does in each case, account must be taken of the fact that when the flywheel is blocked the 100 pounds moves over the same space as the car, while with the flywheel free it will move over an additional space, due to the rope unwinding from the axle. The simple principle of momentum used above is now no longer sufficient, and the angular momentum of the flywheel must be found, and the work done in rotating the wheel added to that done in moving the car and wheel along the track.

Lighting Cars.

The *Railroad Journal* says that the horrible accident which occurred on the Cincinnati, Hamilton & Dayton Railroad on January 17, reiterates with terrible emphasis the necessity for taking every precaution to prevent the repetition of such calamities. In this case, as in other instances of a similar kind, passengers were fastened in the wreck and burned to death in the presence of the onlookers, who could give no aid, and were helpless to prevent the awful agony which was greater than that of a martyr burned at the stake.

Heating by steam is making progress, but not as rapidly as circumstances demand, as is shown by this and other accidents; but the influence of State legislation and the Railroad Commissioners is now exerted in favor of its general introduction; although it will probably require the sacrifice of more lives, the stimulus of public indignation, and the strong hand of the law to overcome the lethargy of railroad directors and managers.

The subject of lighting cars has received less attention than heating, because the danger is less apparent. That carrying several gallons of very combustible oil, which is distributed in a car where, in case of an accident, it will be most effectually scattered, is a source of great danger, is very obvious. Besides this, if cars are ineffectually lighted, it imposes upon passengers from three to six dismal hours in which reading is impossible, and they are driven to reflect on their misfortunes and shortcomings, which leads to a low state of dejection and melancholy.

Railroad companies have not the excuse any longer that there is no satisfactory system of lighting cars excepting oil lamps. It is not our purpose to sit in judgment on the relative merits of the various systems now in use; but it can be said confidently that if there is none better, the Pintsch system is giving satisfactory results. It has been mentioned in these pages before, that an unwillingness to profit by the experience of others appears to be a national defect in the American character. Precedents are, however, useful guides. In the matter under consideration we have the fact before us that the Pintsch system of lighting cars is used extensively in England, Germany, France, Holland, Italy, Austria, Russia, Sweden, Denmark, Switzerland, Egypt, Brazil, and also in this country, on nearly, or quite, 30,000 cars. The use is not recent either, but has extended over a sufficiently long period to fully test the efficiency of the system. The rate of increase also shows that its use has been sufficiently satisfactory to lead to a rapid extension, as from 1883 to 1886 about 23,000 cars were equipped with it. In this country it is used on the New York, Lake Erie & Western Railroad and ferry boats; the West Shore Road and boats; New York, Providence & Boston; Chicago & Atlantic; New York Central & Hudson River; Boston & Albany; Old Colony; New York & New England; Louisville, New Albany & Chicago; Cincinnati, Hamilton & Dayton roads; Pullman's Palace Car Company; Wagner Palace Car Company; Providence & Stonington Steamship Company's boats; Hoboken Land & Improvement Company's boats; and the New Jersey Central and the Cleveland, Cincinnati, Chicago & St. Louis Railroads are erecting works for future use. In all over 1,000 cars in this country are lighted by this system.

The following description will give a general idea of its essential features:

Process of Manufacture.—The material used for the manufacture of Pintsch gas is crude or refined petroleum, or the residual products of coal oil distillation. Crude petroleum is the cheapest material, and the one generally employed. The oil is passed through suitably arranged iron retorts kept at a high temperature by a coal fire below them. The furnace is of such design that the retorts are evenly heated from end to end, and are kept at such a temperature as to thoroughly convert into gas the oil, which is fed into them through specially arranged pipes and graduating cocks. The product is a rich and permanent gas, and of the highest illuminating power known in the art. From the retorts it

passes through water seals, and is led by a pipe to the condenser, where it is cooled. In this it deposits the vapor of water, tar, etc., mechanically carried over with the gas. From the condenser it passes through a washer, which further purifies it, and then through lime purifiers, which effect the removal of all traces of impurities which may still remain. It is then measured and passes to the gasholders, from which it is drawn by the compressor and stored under any desired degree of compression in the tanks, from which pipes lead wherever it is convenient to convey it for use. The process is a simple one, very direct and economical. A plant capable of making all the gas required for 500 cars is contained in a building 26 ft. 4 in. by 38 ft. 6 in., one story in height. The storage tanks may be placed where it is most convenient, and are larger or smaller in proportion to the requirements of the service.

Distribution to Cars.—From the storage tanks pipes are laid to such points in the yards as are most convenient for charging the reservoirs of the cars. These pipes are provided with suitable valves, and by means of special hose, with quick-acting couplings, the gas is transferred to the tanks under the cars. These tanks are filled to a pressure of 150 pounds. A very much higher compression can be obtained if desired, but experience has shown that it is not good practice to compress the gas more than is needed. The tanks are filled very quickly, and no time is lost on this account, even when the filling is done at an intermediate station. A stop long enough to supply the engine with water or coal, or to change locomotives, is sufficient for filling the tanks.

Pressure Regulation.—At the pressures at which the gas is charged into the tanks, its combustion in lamps is impossible without perfect regulation. This pressure, it should be remembered, constantly though very slowly diminishes as the gas is burned, and the conditions of satisfactory lighting demand that while any gas remains in the tank in excess of atmospheric pressure it shall give as good a light as when the tank is charged to its full capacity. The regulator is placed under the car, and without attention and under all conditions of service maintains a constant pressure of gas on the pipes leading to the lamps, whether one or all are burning, or none are in use. It is entirely automatic, and when adjusted and put in position needs no further attention, and the cover of the iron box containing it need never be removed.

The Lamps.—The lamps manufactured for railroad service are of great variety, and are adapted to every kind of coach. Those for passenger cars are all made upon one principle. They are suspended from the ceiling, and one of the suspending arms furnishes the gas-way. Two or four burners are used, as desired. These are inclosed in glass globes, which perfectly shield them from disturbing air currents, and place them wholly beyond curious or malicious interference. Above the flames is a white porcelain reflector, which greatly aids in the distribution of the light rays, and very much increases the brilliancy of the illumination. These lamps are shadowless, and, as travelers by the lines on which they are employed have observed, four lamps in a passenger coach of full size, give an illumination which permits the passenger to read easily and comfortably.

After the works and the machinery are erected it is said that this system is cheaper than lighting by oil; it is certainly much cleaner and safer, and, as remarked in the early part of this article, we are not prepared to sit in judgment on all the methods of lighting now before the public, but it may be said confidently that if no better system can be found than the Pintsch, railroad companies should adopt it in preference to oil, if for no other reason, to prevent such dreadful accidents as the one already referred to and others equally horrible.

Mr. Jno. West on Gas and Electricity.

At the annual meeting of the Manchester Association of Engineers, the President (Mr. Jno. West, M. I. C. E.) delivered a very comprehensive address, a large portion of which dealt with the subject of gas and electricity. An abstract of his remarks in this respect is appended:

Having referred to the gradual advance made in electric lighting from the time of the display at the Paris Exhibition of 1878, and subsequently in conjunction with gas, at the Crystal Palace, in 1882-3, the President noticed the first legislation in regard to the new system of illumination—the passing of the Electric Lighting Act of 1882—and the important amendment lately made therein by the extension of the time which must elapse before undertakings can be acquired by local authorities, and the modification of the terms under which the transfer is to be made. These alterations, he pointed out, had encouraged electric lighting, and companies had sprung up in London and the provinces to lay down plant for supplying the light. In some cases, where the gas works belong to the municipalities, they themselves had obtained powers

to supply the electric light as well as gas. Ten companies had been formed for lighting London, with a united capital of more than £3,000,000 sterling. The systems under which electricity is supplied by these companies—viz., the direct continuous current and storage, and the alternating transformer systems—were next described; and credit was given to electrical and mechanical engineers for having produced some very superior steam and gas engines and dynamos, and generally improving the plant, so as to ensure steadiness of light. The charges, Mr. West stated, were 7d. to 8d. per Board of Trade unit of 1,000 watts; and he added that some companies would not furnish a supply to a consumer under a minimum charge of £14 per annum.

While admitting that electricians had made some progress in perfecting machinery for securing a better and more regular supply of electricity, the President said it must not be forgotten that improved lighting by gas had also made very rapid strides. He mentioned that 13 years previously he read a paper before a Philosophical Society upon the "Economic Consumption of Gas;" and another during the year 1882, at the Smoke Abatement Exhibition in Manchester, where he displayed a number of defective burners that had been used by the consumers, and compared them with the more recent and improved burners then obtainable, when it was found that a great many consumers were not getting out of the gas anything like the illumination it would afford even with a good ordinary burner. Since that period, two new systems of burners had been perfected—those of the regenerative type, with which were associated the names of Siemens, Sugg, Wenham, Fourness, and others, and the incandescent burners of Welsbach, Clamond, and others. The burners, particularly those of the regenerative kind, had come into general use, and from them a better light could be obtained with from one-half to one-third the quantity of gas. In support of this statement, the results of tests of the various kinds of burners referred to—made by Mr. A. Smith, of Aberdeen, and Messrs. W. Foster and C. J. Lambert—were given.

The President next proceeded to compare the relative cost of gas and electricity, with equal light from each. He pointed out that eminent electricians state that a 16-candle power incandescent lamp is calculated to last about 1,000 hours, during which time it would absorb 60 Board of Trade units of electricity. The cost of this at 8d. per unit, would be 40s., to which must be added 3s. 9d., the cost of the lamp—making a total of 43s. 9d. per 60 units, or 16,000 candles. To make the comparison clear, he gave the cost of gas in London, Manchester and Aberdeen to produce the same amount of light, both with ordinary and regenerator burners. The results are shown in the following table:

	Quality of Gas.	Consumption to Produce 16-Candle Power per Hour.	Consumption Required for 1,000 Hours.	Price per 1,000 Cubic Feet.	Cost per 1,000 Hours.	No. of Times Gas is Cheaper than Elect'y.
<i>Ordinary Burners.</i>						
London.....	16	5.00	5,000	2 6	12 6	3.5
Manchester.....	20	4.00	4,000	2 6	10 0	4.4
Aberdeen.....	28	2.88	2,880	3 6	10 1	4.3
<i>Regenerative Burners.</i>						
London.....	16	2.50	2,500	2 6	6 3	7.0
Manchester.....	20	2.00	2,000	2 6	5 0	8.7
Aberdeen.....	28	1.44	1,440	3 6	5 0½	8.7

In reference to the preceding table, the President remarked that possibly he might be charged with having compared the electric light with both the best ordinary and regenerator burners. To this he could only reply that these burners were within the reach of all consumers, and that it would be to their great advantage to adopt them. He pointed out that he had compared the gas with an electric lamp assumed to give the same light throughout the 1,000 hours; but this was not the case, as it was found that after they had been used for a time the carbon filament became volatilized and deposited on the glass, consequently the size of the filaments was diminished and the surface of illumination reduced—the carbon on the glass further reducing the light. These facts had been confirmed by the experiments of Mr. Preece, Chief Electrician to the Post Office, who stated that ordinary commercial lamps consuming 3.54 watts per candle power when new, required 6.1 watts per candle power after burning 900 hours—the mean absorption being 5.25 watts per lamp. Stated the other way, it appeared that the candle power of the lamps after burning 900 hours was only 58.5 per cent. of the initial duty; and the mean value of a lamp during its life was only 67 per cent. of that which it possessed when new. Assuming an average use of four hours per day for a lamp, this meant not only that all incandescent lamps must be renewed before 225 days (when their luminosity was

little more than half what it was when new), but, taking all the lamps in an establishment together, three should be provided to do the work of two if the intended average lighting effect was to be maintained. The President said he was prepared to admit that the introduction of the electric light would be advantageous compared with gas consumed in ordinary burners, when a room was low-pitched, without any means of ventilation, and where a number of people were assembled assisting in the vitiation of the air. At the same time he was bound to say that by the adoption of regenerative gas burners not only would the maximum illuminating power per cubic foot of gas be obtained, but the products of combustion would be carried away without being permitted to enter the room, and the warm vitiated air would be removed as it rose to the ceiling. It appeared to him that some people preferred the electric light for reasons outside its advantages as a lighting agent—one because of its value as an advertisement, another because it was fashionable, and so on. But let the cause be what it might, he saw no reason why they should not have the electric light if they had a fancy for it, and were willing to bear the additional expense attending its adoption.

Mr. West then proceeded to give his views as to the cheapest and best way of producing and delivering electricity to the consumer under varying circumstances. He said he had been informed that in one town a complete electric lighting plant, driven by steam power, for the supply from a central station of 3,000 incandescent lamps of 16-candle power, with cables laid along the streets, would cost about £20,000. Mr. J. Ferguson Bell, of Stafford, had stated that in his town it would cost £14,500 for a like installation without reckoning the cost of land. Then there was the plan of supplying oneself (provided the number of lights was sufficiently larger) by means of a complete plant, driven by a gas or a steam engine, on the consumer's own premises. He had been supplied with the cost of a complete electric installation, including fittings for 320 incandescent lamps of 16-candle power each, which had been working for about two years at one of the banks in London. The plant was driven by gas engines, and the building being very dark, the lamps had to work for about 1,800 hours per annum. The following were the figures supplied to him:

Outlay on Plant.

Two 9-horse power "Otto" gas engines and fixing	£650	0	0
Two dynamos.....	300	0	0
Two sets of accumulators.....	1,250	0	0
Fitting up the bank throughout with wire, lamps and all accessories, including architect's charges	800	0	0
	£3,000	0	0

Working Expenses.

Gas used, 2,000,000 cubic feet, at 2s. 6d. per 1,000 ft.	£222	0	0
Proportion of wages of attendant who does other work.....	75	0	0
Oil, waste and water.....	25	0	0
Repairs to engines and dynamos, and depreciation at 10 per cent.....	95	0	0
Repairs to accumulators, and depreciation at 15 per cent.....	187	10	0
Cost of renewals of incandescent lamps (each burning 1,000 hours, at 3s. 9d. each).....	108	0	0
	£712	10	0
Interest on capital, at 10 per cent.....	300	0	0
	£1,012	10	0

Current of electricity supplied, about 35,500 Board of Trade units.

Analyzing the foregoing figures, the President pointed out that the cost per Board of Trade unit for generating electricity, including wear and tear and interest on capital, was 5.58d.; interest on fittings, 0.56d.; renewal of lamps, 0.7d.—total, 6.84d. If the bank had obtained electricity from a company supplying from a central station at 8d. per unit, the total cost to them would have been as follows: Electricity, 8d.; interest on fittings, 0.56d.; renewal of lamps, 0.7d.—total, 9.26d. So that by generating electricity on their own premises they saved 2.42d per unit, or £357 19s. 2d. per annum. In this case, as shown by the accounts, accumulators were employed, so that the electricity could be generated during the daytime with smaller gas engines than would otherwise be required; but the loss of efficiency by the use of accumulators was about 20 per cent., and was a great drawback. He thought it would be found in practice that the most economical and satisfactory way of producing and supplying electricity to the consumers would be by gas engines on their own premises, or by a system of very small central stations, where a few houses or shops in close proximity could be worked by the direct system of distribution. By this plan it would be

possible to avoid expensive outlay on buildings, and at the same time to advantageously use the existing gas mains, as well as dispense with the cost and maintenance of an electric meter on the premises. The cost of generating plant for 400 16-candle power incandescent lamps, burning 1,800 hours per annum, on this plan of electric lighting by the use of gas engines and dynamos on the consumers' premises (already fitted up with wires and lamps) would be as follows:

Outlay on Plant.

One 20-horse power gas engine, fixed complete.....	£500	0	0
Dynamo	260	0	0
Slides, disc-wheel bearing and fixing, switches and cables in house.....	140	0	0
Total.....	£900	0	0

Working Expenses.

Gas used, 2,160,000 cu. ft., at 2s. 6d. per 1,000 ft....	£270	0	0
Proportion of wages of attendant.....	75	0	0
Oil, waste, and water.....	35	0	0
Repairs to engine and dynamos, with depreciation at 10 per cent.....	90	0	0
Proportion of rent, etc.....	100	0	0
	£570	0	0
Interest on capital, at 10 per cent.....	90	0	0
	£660	0	0

Current of electricity supplied, about 43,200 Board of Trade units.
Cost per unit of electricity, 3.66d.

In the case of an installation of direct generating plant for electric lighting by the use of gas engines and dynamos on the consumer's premises (already fitted up with wires and lamps), to supply fifty 16-candle power incandescent lamps, burning for 1,800 hours per annum, the cost would be as follows:

Outlay on Plant.

One 4-horse power gas engine, with dynamo, etc....	£275	0	0
--	------	---	---

Working Expenses.

Gas used, 270,000 cu. ft., at 2s. 6d. per 1,000 ft.	£33	15	0
Proportion of wages of attendant.....	18	4	0
Oil, waste, and water.....	8	0	0
Repairs	6	0	0
Depreciation	13	10	0
Rent.....	4	0	0
	£83	9	0
Interest on capital, at 10 per cent.....	27	10	0
	£110	19	0

Current of electricity supplied, about 5,400 Board of Trade units.
Cost per unit of electricity, 4.93d.

By this plan electricity could be supplied, as shown by these examples, at prices varying from 3.66d. to 4.92d. per Board of Trade unit, according to the size of the installation, inclusive of working expenses, repairs, depreciation, and interest on capital. The usual charge by the London electrical companies, whose supply is generated for extensive districts in large stations driven by steam power, is 8d. per unit; showing a saving of 4.34d. and 3.07d. per unit respectively in favor of the gas engine scheme. To explain how the charge for working by gas was obtained, the President stated that he first took the quantity of gas required per indicated horse power per hour at 20 cubic feet. With this quantity of gas a maximum of eight lamps of 16-candle power each could be maintained per hour; and by allowing a little extra for irregularities, and taking 50 cubic feet of gas to produce one Board of Trade unit, the gas would cost 1½d., to which must be added the other figures in the table of working expenses.

Mr. West explained that the reason electricity could be distributed to consumers by gas engines cheaper than from a large central station was because the very expensive cables for distributing the electricity (which in most cases take one-third of the capital employed) could be dispensed with, as also the further expenses for renewal after the cables had been in use for a time. It was stated that Mr. Edison's cables in Berlin only last three years. These cables cost £90,000 for 36,000 lamps of 16-candle power and 144 arc lamps. From these facts it was quite clear that the interest on the first cost and maintenance and renewal of distributing plant alone would be more than the cost of gas delivered on the con-

sumer's premises from the existing mains. He expressed the opinion that the Corporation of Manchester were quite right in taking steps to obtain a Provisional order from the Board of Trade for supplying the electric light, for which they could put up plant themselves, or employ other parties to supply them. They had excellent distributing plant for the purpose in the existing gas mains, which, by the aid of gas engines, would supply a power available at any time, requiring no constant attention, and causing no nuisance from smoke. These engines were already extensively used; Messrs. Crossley Bros. having sold 550 for the purpose. Where the outlay on plant was an impediment, he advised corporations and gas companies to throw more enterprise into their undertakings, and provide and let out on hire gas engines and dynamos in the same manner as they now let out cookers and gas stoves. In some cases it might even be advisable to sell the gas at a cheaper rate for electric lighting and heating purposes.

The President said he had not referred much to the use of arc or incandescent electric lamps for public lighting, because it had been proved over and over again that these lights could not possibly compare with improved gas burners and lanterns, either for cost or efficiency in lighting power. In many cases where arc lights of high power were employed on outdoor work they had been superseded by the Lucigen and Wells portable lights. Before leaving this subject, he said it must not be forgotten that in nearly all cases both gas and electric light are obtained from the energy contained in coal, and that gas companies and corporations who own gas works could produce as much light direct from the gas made from a ton of coal (if properly applied) as could be derived from a ton of coal by any other means, besides having the resulting coke, tar, and ammoniacal liquor to dispose of. Therefore, as far as he could judge, gas must remain by far the more economical of the two methods of lighting.

Mr. West concluded his address with an appropriate reference to water gas. He remarked that the subject of water gas had been brought very prominently before the public during the last year or two, more perhaps for the purpose of floating speculative companies than because of any real novelty in it; for at least 30 years had elapsed since it was new to English gas engineers. Many had been the trials of variations of the same principle, owing to the extreme simplicity of the apparatus and the large amount of work that could be done on a small area; but the question of ultimate economy had often prevented the success of schemes which were otherwise satisfactory. He explained that he was referring more particularly to the use of water gas for general lighting purposes, as there were many examples in England of its admirable qualities as a heating agent. Having described the method of generating the gas, he pointed out that there is a great difference between the circumstances of the production of water gas as a lighting agent in America and England, inasmuch as in America the petroleum oil used to invest the gas with lighting properties is easily obtained at a very low price, and the price of coal gas is much higher than it is in this country. A greater margin thus exists between the two kinds of gas. As a heating agent water gas was, he said, very valuable where a high flame temperature was desirable; as the theoretical temperature was about 5,000° F., while that of coal gas was about 2,500° F. He went on to show that mistaken notions are frequently held by persons not specially interested in the question, though of thoroughly scientific education, as regards the heating value of ordinary coal gas compared with the so-called "heating gas." He said the fact was that, roughly speaking, the better the lighting qualities of a gas the greater its heating value; and a far larger number of heat units were contained in a pound of ordinary coal gas than in the same weight of the best "heating gas" (taking the term "heating gas" to be simply a name to distinguish it from a gas which had not only greater heating value but lighting value as well) yet produced. As a lighting agent water gas had to be carbureted, or employed with some material capable of being raised to incandescence, such as magnesia, in the form of a comb, which, however, required a frequent renewal. English engineers who had visited America to inspect the water gas processes in use were of opinion that it might be an advantage to adopt the same system to a certain extent in England if petroleum could be bought at a sufficiently low price to make the gas a commercial success: but he thought this was very questionable.

ACCORDING to the annual report of the Manufacturers Natural Gas Company, of Pittsburgh, the gross receipts for the year are returned at \$235,149.38, and the expenses for same period were \$151,839.97. The net receipts were \$83,309.41. During the year the Company claims to have expended \$58,128.27 in "permanent improvements," a portion of which was devoted to the burying of 36 miles of 12-inch pipe. The main mileage of the Company is returned at 136.

[Concluded from page 139.]

The Dangers of Electric Lighting.

BY S. Z. DE FERRANTI AND FRANCIS INCE.

In order to use the electrical current two mains or conductors are required, an out main from the central station, and a home main (and one intermediate or third main is also required where the three-wire system is used), and each lamp that has to be lighted has one end of the filament joined to the one main (say, the out main), and the other end to the other main (say, the home main), the passage of the current from the one main to the other through the carbon filament causing the filament to incandesce and to give light. Now, if the mains from the central station are constructed with one tube of copper within another, and with insulation between, as shown in the figure, the central ring, marked *A*, being the out main, say, and the outer ring *B*, being the return or home main, the shaded part between the two being the insulation, the only leakage of current that can ever take place is, say, from *A* to *B*, if there is any defect in *C*, and the current returns to the station through the leak by *B*, without passing through a lamp or doing any work, and

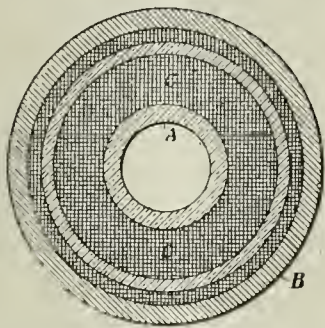

if the leak is so serious between *A* and *B* that it causes a larger quantity to go back to the station than the bridge there will stand, the bridge melts before any damage is done to *A* or *B*; and if another main or wire actually comes in contact with *B* the current will not leave *B* and find the way back by the earth (as it would do if two separate out and home conductors were used), but it is controlled by *A*, and any leakages can only be to *A*. Hence, with a conductor constructed, as above shown, with a current passing through it of 10,000 volts, any one may hold *B* in their hands and they will receive no shock and no current will pass into them. This has been practically demonstrated by a test on the underground railway, where one of the writers held, as many others did, *B* in their hands, while a current of great pressure was passing through it, a pressure that would have meant instant death if it had been possible for the current to leak from *B* and pass through the body to earth. Thus we have the double safety, the bridge and nature of the conductor used, this safety being not only, as the reader will observe, a safety against fire, but it is an absolute safety to human life. And thus a man may work in close proximity to a conductor constructed as suggested, in fact, he may sit on it while he is working, and he will be out of all danger, and he is no longer, as Mr. Edison suggests, in fear of a "death-dealing current," for the current, whatever its pressure, whatever its quantity, is so controlled as to be absolutely harmless. Thus, to sum up the meaning of the above concentric mains, we may say that, whatever fault may occur, the whole effect is produced and contained in the main itself, and it is impossible that there can be, and there is in fact no danger and no damage done outside. We have thus a perfect protection for life and property from all forms of current.

Again, Mr. Edison says there is "no known insulation which will confine these high tension currents for more than a limited period;" and again he says, "the influence of the air or of gas or other agents renders it (the insulation) finally very susceptible of being pierced by a spark of static electricity." Mr. Edison would have been more accurate if he had said that there was no insulation known to him which would confine these high tension currents for more than a limited period; and, again, how can the air, gas or other agent get at the insulation if it be confined between two tubes in the way suggested and they are properly joined the one tube to the next? Again, if the mains be constructed according to the figure, and a spark of static electricity did pierce the insulation, what would be the effect? There would be no danger, no external damage; too great a quantity of current would flow over the bridge, and the bridge would give way, and, as before explained, no detrimental effects would be produced. But there is an insulating substance known which was manufactured before the commencement of the Christian era of which specimens that have been exposed to the air for centuries still exist in perfect preservation. How will such an insulator stand when hermetically sealed between two tubes? Then, again, Mr. Edison says, "the risk, too, is greatly increased by the fact that consumers who are

supplied with current from a low tension system are accustomed to handle their electrical appliances freely, knowing them to be harmless; I say nothing of the injustice to vendors of harmless supplies of electricity." Here, again, Mr. Edison knows, and no one better, that even if the current is sent out from the central station at a tension of 10,000 volts, the tension is lowered at distributing stations by a suitable device, and that current the consumer has to handle is only at a pressure of 100 volts, and the pressure is so lowered and controlled that by no possibility whatever can the higher pressure get into any house. What, therefore, is the difference in the danger to the consumer whether the current has an initial pressure of 100 volts or 10,000?

Mr. Edison speaks of the alternating current as being more dangerous to life, and no doubt it is, if a high pressure were used in the customers' houses; the writers were, however, both present when Colonel Armstrong, as the representative of the Board of Trade, called upon them for the purpose of trying the effect of shocks from an alternating current at varying pressures, and in our presence he first of all took a shock from an alternating current machine at 50 volts; he then had the pressure increased to 100 volts, and then to 150 volts, and then to a pressure of 200 volts, at which pressure he said he was satisfied, and he could bear the 200-volt shock with perfect ease, being a pressure of twice that used in consumers' houses; in fact, in the Board-room of the London Electric Supply Corporation there are two openly exposed terminals, and the Directors constantly take hold of these, the effect of the 100-volt alternating shock being hardly perceptible, and being rather pleasant than otherwise. Further, we have had several accidents where men in the station have received a shock direct from the machine with a 2,400-volt alternating current, but not in one instance has death resulted. Mr. Edison speaks of the danger to life of alternating currents at low pressure, but it must be borne in mind that the specimens experimented on at Mr. Edison's laboratory were pickled and prepared so as to make the effects of the current as deadly as possible, and were therefore placed in an unnatural condition.

This article shows that the saving of copper in the mains or conductors is enormous as the tension increases, and what this means may be made more clearly apparent by a statement of the fact that if the pressure from the station was 100 volts only, the stations to light London could not be placed at a greater distance than a mile apart, each station lighting a half-mile radius, as otherwise the copper mains would have to be of such an enormous size to carry the quantity of current that would be required at this low pressure, that the cost of mains alone would render the price at which the current could be supplied so high as to make lighting by electricity impossible.

Again, it is much more costly to build a large number of small stations than one large station, and every small station requires its staff, its engine drivers, etc. In a large station one man can drive a 10,000-horse power engine which will light 200,000 10 candle power lights, whereas with small stations and small engines, say of 250-horse power each, which would light 5,000 10 candle power lamps, each engine must have its attendant; and the question is not, as Mr. Edison would suggest, a mere question as to saving a few pounds "in investment in real estate and copper;" it is a question of saving so much as to make the difference between success and failure, where it is necessary to compete with gas at a low price. But this is not all; in large cities it is impossible to buy land at every mile, and to put up a central station for the manufacture of electricity, for the station is a nuisance, and one is perpetually harrassed with litigation; application after application is made for injunctions; the taking of coal in the large quantities required is a nuisance; the smoke is a nuisance, and only high-priced steam coal can be used, and that, too, saddled with the heavy expense of cart carriage; the vibration and noise from the engines is a nuisance, and stations in the residential parts of any city will be stopped one after the other by injunction.

Again, at these small stations spread over a city, to get water is a difficulty, and in consequence power can only be obtained at a very high rate of coal consumption; whereas, with a suitable site at a distance, the quantity of coal used can be reduced enormously, making a saving which will alone go far towards a dividend on the capital expended.

These are all circumstances that require most serious consideration, and Mr. Edison's argument on these points is in fact a mere argument in favor of a monopoly for his low tension system, a system which can exist and be carried on profitably in America, where the price of gas is enormous; a system which would render electric lighting impossible in London with gas at 2s. 5d. per 1,000 cubic feet, and a system which makes the people of America pay a price for their lighting unnecessary to give a good return on capital invested on a better and a less costly system.

Mr. Edison points out that a larger number of fatal accidents have occurred through electricity in New York than in any other city in the world, and gives the reason that New York has a greater number of wires overhead than any other city in the world. No doubt this is the reason, coupled with the fact that probably in no other city in the world are the overhead wires arranged more negligently and with more disregard for the care of human life. There can be no doubt but that overhead wires, whatever the care may be that is taken with them, are, and always must be, a danger; but with conductors placed underground, and with due care, and properly constructed, there can be no danger whatever. Mr. Edison has pointed out that in this country the safety of the people is placed in the hands of the Board of Trade, a body we have found most obliging and most reasonable in their requirements, while insisting with the utmost severity that no system shall be adopted which does not give absolute safety to human life, and who, after seeing our work, have been perfectly satisfied to advise the government to pass our Act, which enables us to deal with a 10,000-volt current.

Mr. Edison does not deal with the transmission of power from those sources which nature gives us for nothing at certain centers; we refer to water power, and from which, by the aid of high pressure electricity, and high pressure electricity alone, can the force be transmitted to a distance and utilized for the purposes of man; according to Mr. Edison these forces are to run on unutilized forever as they have done for ages past. His argument that because a nitro glycerine factory is dangerous on the surface of the earth we should not think of putting it underground, is not applicable to the subject of electricity or to the putting of electric mains underground, though we cannot say that the idea of the nitro glycerine factory underground is so absurd as Mr. Edison appears to think; for it will be within the memory of many of our readers that about fifteen years ago a barge laden with gunpowder, on the Regent's Canal, exploded at the bottom of the Avenue road, where the canal is in a deep cutting, and the opinion of one of our great experts was that this fact saved London, serious as the damage was in the immediate neighborhood. It is clear beyond a doubt that if mains are properly placed underground there can be no danger, and no accident can take place.

We think we have said enough to show that the dangers of electric lighting are no more in the high tension system than the low, provided both systems are carried out with equal care and all proper safety devices are used in the one case and in the other; without these devices and without this care neither system is safe, and it is clear beyond a doubt that the low pressure system is not safe as at present carried out in New York, and it never will be until the State steps in and the use of electricity is regulated there by well-devised rules and under the supervision of competent officers; but Mr. Edison is as far behind the time when he suggests that no station shall send out a current at a pressure exceeding 100 volts as the alarmists were when railways were first introduced, and it was considered that no train could in safety ever run at a rate exceeding twenty miles an hour.

No doubt if a train ran at only ten miles an hour an accident would not have such serious results as with a train running at fifty miles, but is this an argument why trains should not run at fifty miles per hour? We have to consider the percentage of risk, and this we find has not been materially increased by the increase of speed. So it is with electric pressure. As the pressure increases, extra precautions have to be taken with regard to safety, and we believe with Sir William Thomson, who stands as an authority in the world of science as high as Mr. Edison, that it is not a question whether a pressure of 10,000 volts (the highest pressure yet utilized) is to be used or not. The pressure may be anything so long as proportionate precautions are used, and we think it may be that in a few years' time people will think as little of 10,000 volts as we do now of 1,000, and will laugh at the present alarmist idea that in a pressure of 100 volts the limit of safety has been reached.

Mr. Edison says in his article: "The public would scarcely be interested in the details leading up to the conclusions to which I have come, for the reason that it would involve a mass of matter such as they have been attempting to digest during several months past." We have not adopted Mr. Edison's dogmatic method of dealing with the subject, and do not know to what mass of matter he refers. We have avoided attempts to give results the weight of our opinions without giving reasons; we have explained as clearly as we are able our views, giving such reasons as would enable the general public to follow our arguments without, we hope, too much trenching on the land of technical science, and we trust our readers will see that there are other arguments besides those of Mr. Edison, and that there are reasons why the dangers of electric lighting under a high pressure system are no greater, if they are so great, as those of a low pressure system, for which Mr. Edison clearly claims (while he disclaims) a monopoly.

Mr. Edison very properly gives great weight to facts. Let him then consider that in New York the deaths through electric shocks have been very frequent, with a tension, we believe, never exceeding 2,000 volts, and rarely exceeding 1,000; while in London, where for years we have been using a tension of 2,400 volts, with miles of both overhead and underground conductors, we have never had a single accident with our mains or a single death. Why this difference between London and New York? The reply is, that here our work is done properly, there it is not. Our work is put up to last, theirs in New York to serve the purpose of the moment.

If the reader has followed us so far and will allow us in closing this article to be prophetic, we will say that in the future our railways will be worked, our lighting will be done, our power will be transmitted to a great distance; all this will be done entirely by the aid of high pressure electricity; it is high pressure in electricity like high pressure in steam, which is going to carry—which is carrying—everything before it, and this high pressure will be used, and will be doing the work of the world, when the low pressure system Mr. Edison now so strongly advocates has passed away and been forgotten.

Three Types of Electric Meters.

La Nature recently published an article descriptive of three types of electric meters that were first publicly displayed at the Paris Exhibition. In the illustrations Fig. 1 stands for a general design of Blondlot's watt-hour instrument. M. Clerc's watt-hour device is outlined in Fig. 2, while the meter of MM. Paccard-Borel is pictured in Fig. 3. The watt-hour devices are for continuous service current, while the last-named apparatus is for alternating work. Blondlot's meter is constructed with two essentially distinct parts—the measuring apparatus and the integrating apparatus. The former of these is an electro-dynamometer whose fixed bobbin with vertical axis is wound with coarse wire and is traversed by the total current furnished to the consumer. The fine wire bobbin placed within the coarse wire one is mounted in derivation between the distribution terminals of each subscriber. The couple exerted upon the movable bobbin by the fixed one is thus proportional to the product, eI , of the intensity, I , of the principal current by the difference of potential, e , at the terminals of distribution. A counterpoise arranged upon an arm mounted upon the axis of the movable bobbin balances the electro-dynamic couple and causes a deflection of this bob-

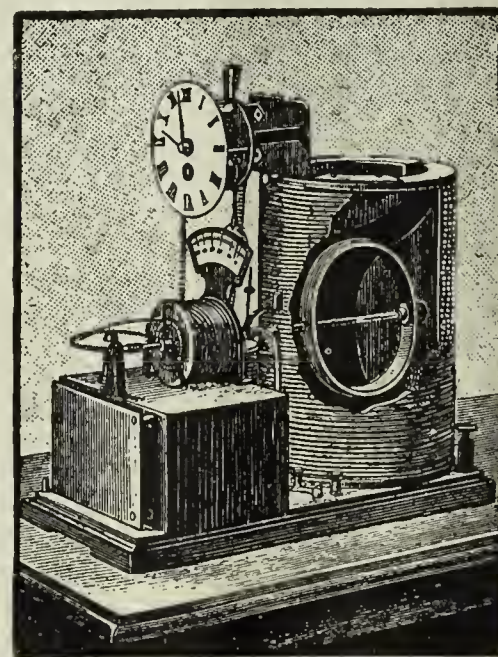

Fig. 1.

bin by an angle proportional to the product, eI . The clockwork movement, an ordinary timepiece, periodically closes (once every 5 minutes in the case considered) the circuit of a special derivation constituted by two solenoids. The effect of the first of these solenoids is to bring back the fine wire bobbin to zero, and that of the second, which is arranged horizontally, is to render momentarily interdependent the axis of an evolution counter which, in every operation, revolves by an angle equal to that made by the movable bobbin before being brought back to zero. The rotations thus given periodically to the revolution counter are totalized, and may be read upon a horizontal dial actuated by an endless screw mounted upon the first axis of the revolution counter.

The movable bobbin, in passing over a vertical dial placed beneath the clock, makes known the power furnished every instant by the apparatus controlled by the counter. The intervals of time that separate two

different gatherings may be read upon the dial of the clock, and the integrations made by the apparatus may be known from the horizontal dial, so that the consumer has under his eyes at every instant all the elements of verification that are necessary to him.

Clerc's meter, shown in Fig. 2, is in principle analogous to Blondlot's, but differs from it in the mode of periodical integration. The clock is kept in motion by a derivation from the line. It carries along, at a uniform angular speed, a crank fixed upon the principal axis. When the power expended is nil, the needle fixed upon the axis of the movable bobbin is in the position represented in the cut.

If a current passes into the two bobbins, the needle is deflected toward the right by an angle that counterpoises, properly arranged upon the

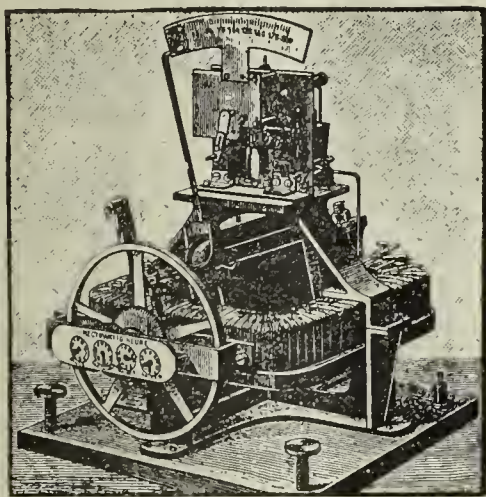

Fig. 2.

axis, permit of rendering sensibly proportional to the product $e I$. The crank carries the needle back to zero once per revolution.

These rotations are transmitted to the revolution counter, and totalized by means of a mechanical arrangement that may be seen in front in the figure. This arrangement consists essentially of a small finger suspended from a lever fixed to the axis of the movable bobbin. When the lever moves from right to left, it carries along the large wheel mounted upon the axis of the totalizer. In moving from left to right, the finger slides over the felly of the wheel, and the rotation effected in the preceding movement continues as in the Blondlot apparatus. The needle indicates the power in watts, and the counter the total of the watt hours furnished to the consumer.

The Paccaud-Borel meter is designed for the measurement of alternating currents. It belongs to the class of motor counters, and is based upon the special properties of the magnetic field produced by alternating currents of great frequency. Suppose there are two bobbins whose axes

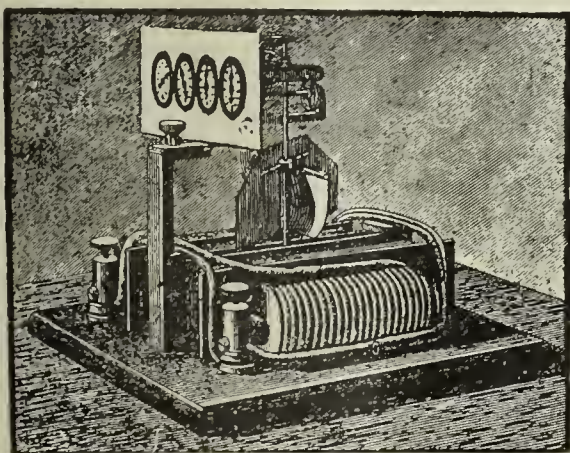

Fig. 3.

are arranged rectilinearly, having an unequal number of spirals, and mounted in derivation, one with respect to the other, so that the total current traverses them at the same time and divides itself unequally at every instant in each of them in consequence of irregularity of the coefficients of self-induction. Each of these bobbins will tend to produce a magnetic field whose intensity will depend at every instant upon the intensity of the current traversing it. The resulting field will be rotary in a direction determined by the attachment of the terminals between themselves. A thin iron disc placed in the rotary field will tend to turn in the direction of rotation of the field, and so much the more quickly in proportion as the field or the current producing it is more intense. Upon arranging vanes, forming a regulator upon the same axis with the disc, and upon properly proportioning the different parts of the apparatus, it is possible, as may be seen, to form a sort of electric motor, which,

between certain limits, will revolve with an angular speed sensibly proportional to the efficacious intensity of the total current.

It is with a view to obtaining such necessary proportions as perfectly as possible that the practical apparatus does not entirely resemble the theoretical one that we have just described.

In the model represented in Fig. 3 one of the magnetic fields is produced by an electro-magnet; on the other hand, the vanes of the brake are movable, and they rise in order to preserve the proportionality at great distances in reducing the value of the resistant couple due to the air. The number of revolutions registered upon a counter is proportional to the quantity of efficient electricity furnished to the circuit.

The Financial Aspect of Natural Gas.

By CHARLES HARRISON.

Although the natural gas industry is in its infancy, being but seven years of age in Pittsburgh, the pioneer city, it has had an important effect on commercial enterprise and economic conditions. Throughout the whole area of natural gas production, from Western Pennsylvania to the fields of Indiana, manufacturing has been stimulated, and the production of manufactured commodities and the consumption of raw materials, vastly increased, the effect of which is not limited to the gas producing territory, but is diffused throughout America. The commercial phases of the industry, the advantages arising from the use of such fuel to manufacturers, the comfort and convenience added to the homes of the people, the advancement in material wealth, additional employment to labor, and various other attributes of a substantial nature, have been widely discussed and generally understood. But the purely financial considerations attending this new industry and enterprise have as yet taken form so little removed from the speculative and experimental as to make definite conclusions nearly impossible. Financiers have nevertheless had considerable experience with the stocks of corporations engaged in the industry. Bonds issued in furtherance of such enterprises are occasionally offered, and order is so gradually emerging from chaos that indications of permanent truth and reliable principles are making their appearance.

The first feature presenting itself to financial consideration is that the industry has from its inception been in the hands of companies or incorporations. Individuals have leased territory and produced gas, and they will probably continue to do so; but in all States wherein natural gas has been utilized as fuel, the distribution has been made to consumers by incorporations. One leading reason why this must continue to be the case is that the places of production are at considerable distance from the places of consumption, the intervening territory being occupied and owned by many persons. In order to obtain rights of way for the pipes through which gas can be conveyed, the power of eminent domain is frequently essential, and this is conferred on corporations exclusively. There is no probability that natural gas can ever be successfully handled by private individuals. A large number of corporations have accordingly been organized to conduct the business. Their stocks have been on the public markets, and their values have become, to some extent, known through the quotations obtained from trading in them. The market has varied widely, the same stocks fluctuating between 135 per cent. of their par value and 32 per cent., often without material difference in their dividend earning capacity, the regularity of dividend payment, or any other known reason than speculative causes. At present, to find a natural gas stock on the market worth par is a decided exception, notwithstanding the fact that several have been paying dividends of from 9 to 12 per cent. per annum regularly for a term of years, and are still in a position to continue them.

All natural gas stocks are speculative and subjected to so many influences against which no human foresight can afford protection, that however valuable they may be as immediate profit payers, they have never risen to the dignity of legitimate investments, and there is no prospect that they ever will. They cannot, for many years at least, from the fact that the sources of supply are beneath the earth, where the human eye can never penetrate, and, unlike many other mining operations, the extent of the "vein" or "lode" cannot be even surmised, much less surveyed. That the wells from which the supply is obtained are really exhaustible, howsoever great may have been their output or uniform their pressure for years, has become a demonstrated fact. No inexhaustible natural gas well has yet been discovered, or one which has not suffered a diminution of pressure, though this fact was denied only a few months ago. Increasing demand upon productiveness has led to more rapid exhaustion, and the rate at which companies have been compelled to seek new territory has been accelerated.

All the great companies, a few years ago, were supposed to be in

possession of territory practically inexhaustible, but there is scarcely a great company in existence, after five years of experience, that is not seeking new territory on account of diminishing supply from those fields which promised to be permanent. That several of the companies have been successful in finding new and prolific territory, is matter for congratulation to the stockholders; but such extensions involve expenditure not contemplated in the earlier days of the enterprise. It is evident that the wells cannot be brought to the pipe; the pipes must therefore be extended to the wells. Every new well drilled, and every foot of pipe laid to make its production available (if, indeed, there be any production), causes an additional outlay of capital which would not have been the case had the wells been originally inexhaustible, as contended. New territory adds still more to the disbursements of the corporation, whether it be obtained in fee or on royalties; and the extension of the pipe system is generally much greater to new territory than from line to well in territory already in possession. It therefore becomes a matter of interest in some cases as to whether these extensions of the pipe lines of companies to new wells in the old or in new territory, and the new wells themselves, which have been found to be imperatively necessary to the successful operation of the plant, should be charged to the stock or the expenses account. It is in dispute and undecided; but in case of leased lines, it makes a vast difference where a division of profits is made the basis of rental. Natural gas may be inexhaustible in the aggregate; and the supply may be all that is claimed for it by the most sanguine of those engaged in the industry. But the extensions of lines and additional expense on account of the exhaustion of wells in all known fields, is a truth too well established to be successfully refuted. How far this may have to be continued, with what rapidity it may be required to supply the demand in the future, cannot be known. This very element of uncertainty will always keep the financial aspects of the industry purely speculative, and render it impossible to attain such a settled condition as to make a legitimate investment, or the stocks of the companies such securities as a court would order trust funds to be invested in, whatever present profits or prospective gains of particular companies may be.

From an economic point of view, it is evident that the cost of production of natural gas must increase as long as wells are exhaustible. Territory becomes scarcer and more uncertain, and the plant of companies larger and more expensive to maintain and operate. At the same time the price to the consumer cannot be arbitrarily advanced to meet this increased cost of production, because there has been no exhaustion of coal fields nor of means of transportation. As much solid fuel of all kinds is within as ready reach of consumers as was the case before natural gas was introduced as fuel; besides which new competitors have appeared in the market. The prolific oil fields of Ohio, particularly, have been utilized for fuel purposes, since natural gas was introduced, and they make a highly successful competitor where conditions are favorable to its supply and gas has to be piped a long distance. Beside oil as fuel, manufactured fuel gases are being devised, and have already supplanted coal in some localities. They are claimed to present nearly as desirable economic features as natural gas itself. Competition must prevent any great advance in the price of natural gas. With constantly and inevitably increasing cost of production, and no opportunity for a corresponding cost to the consumer, what is to prevent ultimate bankruptcy of every natural gas company? Clearly, nothing but the economies rendered possible by experience in distribution, or increasing its effectiveness in use. By the knowledge which comes from experience alone can they be saved. The number of gas companies already rendered insolvent, sold out by the sheriff, or absorbed by other more prosperous companies, is a practical suggestion that it takes something more than gas producing territory, a pipe line, and customers to make a successful natural gas plant. Not a company went into operation without all these, but the number of financial wrecks is very large for the length of time the industry has been in progress, and the supposed profit there is in the business. The great problem is whether the advantages of skill and information derived from long experience in the production and distribution of natural gas will be able to keep pace with the continued cost of production. Whether it be possible or not, the conclusion is unavoidable, that the longer the natural gas industry is continued, the more hazardous it becomes for inexperienced persons to embark in it.

The petroleum industry was long recognized as being the most uncertain and speculative of mining operations; but natural gas is even more speculative than petroleum. All the uncertainty in the production of oil is present in the production of natural gas; but in oil the uncertainty ends. Petroleum has a market throughout the world. Gas has no market except at the end of the pipe. Petroleum having been procured,

a variety of ways of transportation are possible. If in barrels it becomes too expensive, the tank car is available; if the tank car costs too much, the pipe line can be laid down; or the reverse order may be resorted to in extremity. But in handling natural gas but one means of transportation is possible. In natural gas the place of consumption is fixed. No further can it go to get a better price. It has all the disadvantages and uncertainties of oil; while in points of conveyance and market it has none of the advantages. In 30 years petroleum has never ceased to be a speculative commodity; the stocks of the companies engaged in the enterprise equally so. Natural gas companies must be even more of a speculative nature for a longer period, if they continue for that length of time.

Besides their stocks, the bonds of corporations engaged in the natural gas business have a degree of financial interest. The amounts thus far issued have been small, and all issues have been under such conditions as to present little from which satisfactory estimates can be formed of the value of such securities. So far as is known, there has been no uniformity in the issues of bonds by various corporations; and the conditions under which they have been made were so entirely dissimilar each to the other, that only general principles can be relied on in approximating the value of any particular class. The value of a bond depends principally, first, on its validity; secondly, on the credit of the corporation issuing it; thirdly, on the market value of the collateral security or tangible property pledged for its redemption; fourthly, on the rate of interest it bears, and the length of time it has to run. Natural gas companies organized and doing business in Western Pennsylvania have issued bonds, but they have been placed through private agencies on private terms, so that very little is publicly known of the value that has been placed upon them. It may be said, however, that the validity has never been questioned seriously; the companies issuing them having been regularly dividend paying institutions as a rule, and hence of good credit. Each company has mortgaged a plant costing far more than the face value of the bonds to secure the payment; and so long as there is a supply of gas, the collateral security is probably unquestionable. But from the exhaustibility of the wells from which the supplies are obtained, the comparative worthlessness of a pipe line having nothing to fill it with, and the constantly increasing expenditures of established companies more particularly pointed out above, the general rule, that the longer a bond has to run the more valuable it is, does not necessarily apply to natural gas securities. Besides these considerations, the risks of the business are so great, and its speculative character so pronounced, that a high rate of interest becomes essential to indemnify against the contingencies of the investment. The securities issued by a corporation partake, to some extent, at least of the speculative character of the business in which it is engaged. The business risks and expenses of a municipality are at least as great as those of a business corporation, and are liable to be much more so. Natural gas trustees are generally gentlemen of success in their vocation, but without practical knowledge of the details of production or distribution of natural gas. Practical affairs inevitably become more risky under inexperienced management than under the direction of experienced men. Bonds issued by a municipality under such management, and having nothing but public credit behind them, cannot be so desirable as those issued by business corporations, whose affairs are conducted by persons of experience in every department, and which give collateral security on their tangible plants as well as the security of experience and actually invested capital.

Improvements on Coze's System.

The *London Journal* points out that an improvement in inclined gas retorts, after the pattern with which his name is now identified, has been patented by M. Andre Coze, of Rheims. This patent covers the form of the retorts, the method of connecting them to the charging mouthpieces, and the construction of the charging truck or wagon. The retorts are for the whole of their working portion of the peculiarly flattened A-shape which M. Coze holds to be desirable for the proper distribution of the charge; but both ends where they pass through the brickwork of the setting are of contracted area. It is claimed that by this means the disengagement of the gases is greatly facilitated, while the coal is distributed in a regular manner throughout the retort, and choking of the upper end prevented. The charging mouthpieces are made with sockets to fit on the ends of the retorts; and the bends by which the inclined axis of the retort is changed into the vertical are made with duck-feet in order to take their weight off the retorts. The alteration of the charging truck consists in making it carry as many tilting hoppers, provided with automatic closing gates at their lower ends, as may be required for use at one time. Thus, supposing a setting of three retorts to be in use—or,

which amounts to the same thing, three retorts out of a large setting require to be charged at the same time—a truck would be made to take the three tipping shoots, and this would save time. The shoots are provided with means for checking the too rapid fall of coal, or of large lumps, which might otherwise choke the opening into the retort below. It is regarded as an essential feature of this combination that the retort, the charging mouthpiece and the tilting hopper should together at the time of charging constitute a continuous passage for the distribution of the coal in the retort.

ITEMS OF INTEREST FROM VARIOUS LOCALITIES.

THE Asbury Park (N. J.) Gas and Electric Light Companies have an understanding whereunder each refuses to supply light to parties that are in arrears on the books of either Company. There is sound sense in a combination of that character.

AT a special town meeting (Wakefield, Mass.) it was voted not to grant the Citizens Gas Light Company the privilege of erecting poles and stringing wires over the streets for the purpose of furnishing electric currents for light and power.

THE Western Gas and Fuel Company has been incorporated at East St. Louis by Messrs. Henry O'Hara, Jos. W. Shepard and Henry D. Sexton. It is capitalized in \$500,000, and its objects are the manufacture and sale of gas for illuminating and fuel purposes.

THE Peoples Gas and Electric Company, to operate in the villages of Palmyra and Riverton, N. J., has been incorporated by Messrs. Charles H. Edgerton, W. H. Miller and Israel Roberts. It is capitalized in \$50,000. The Company will construct and operate a gas and electric light plant. These are adjoining villages in Cinnaminson township, Burlington county, N. J., and are about 8 miles northeast of Camden. The joint population must be close to 5,800 souls, and both places are growing rapidly. There can be little doubt that a venture of the sort proposed will insure a fair rate of profit from the start.

MR. JOHN LILLIE, President of the newly incorporated Port Townsend (Washington) Gas and Fuel Company, writes us that the projectors are preparing to build their works, and expect to have the same in operation on or before next October. Port Townsend is the capital of Jefferson County, is on Puget Sound near the Strait of San Juan de Fuca, at a point about 44 miles northwest of Seattle. It has an excellent harbor, and is being developed rapidly. To show how its natural facilities for commerce have attracted the attention of those constantly on the lookout for such situations, we may note that ten years ago its population was returned at 593, whereas to-day it shelters no less than 6,500. Further, Mr. Lillie estimates that by the close of the year it will give residence to 10,000 people.

AT the annual meeting of the Grand Rapids (Mich.) Gas Company the following Directors were elected: Messrs. Thomas D. Gilbert, Noyes L. Avery, H. D. Walbridge, Wm. D. Gilbert, Chas. F. Rood and Philo C. Fuller. The Directors made quite a radical change in the personnel of the officers of the Company. Hon. Thos. D. Gilbert has been Secretary and Managing Director of the Company for many years—from its organization almost. He has in that time made the Company one of the best in the country, and while it has been profitable to its owners, it has also been considerate to its patrons, who have had the benefit of good gas at extremely low rates. In consideration of his years of activity the Directors determined to put the clerical labor on someone else, as their choice of officers will show. In organizing they made the following appointments: President, Hon. Thos. D. Gilbert; Vice-President, Noyes L. Avery; Secretary and Treasurer, H. D. Walbridge. In their annual report the Directors say they are "gratified to be able to report a very satisfactory condition of the property of the Company, and nearly the usual annual increase in all departments of its business." Commenting on the use of electricity, the report says: "The increase in the output of gas has been somewhat affected by the experiments now being tried by several of our large customers in the use of electricity. We have no fears for the future in our competition with electricity, unless very great economies can be introduced in its generation and distribution. As an offset to any future developments in that direction we are constantly doing something in the way of improving methods and economies in management, while our residual products are constantly increasing in value. It is well known that the price at which gas can be sold at a profit depends largely on the quantity that can be disposed of after the means for its production are established. The people of Grand Rapids

have always been liberal patrons of the Gas Company, and we have endeavored to meet them more than half way by always keeping our prices at the lowest point consistent with reasonable dividends on our investment. We can point with pride to the fact that while the average price at which gas is sold in the United States is about \$1.85 per 1,000 feet, in this city it is \$1.14, while some of our largest customers have it as low as 90 cents. The wisdom of our Common Council in never having given serious encouragement to an opposition gas company is clearly shown by the fact that among the 20 cities in the Union where opposition companies have been given franchises there is no competition, and in not one of them is gas sold as cheaply as in this city. The low price at which gas is sold here has encouraged its use, for cooking and heating, and the sale of stoves is rapidly increasing. The Common Council has also come to the conclusion that gas is the best and most economical means of lighting the streets, and when they give us permission to light the lamps 'all dark hours,' instead of by moonlight schedule, every one will be satisfied."

WE congratulate the management of the Grand Rapids Company on the success that has attended their efforts, the greater part of which, however, we make bold to assert, is fairly chargeable to the unremitting attention and liberal policy that have always been marked features under the administration of President Gilbert.

MR. KEPLINGER has introduced into the Lower House of the Maryland Legislature a measure which affects the Baltimore Consolidated Gas Company. Briefly stated, the leading features of the Keplinger scheme are appended: Sec. I. declares that the price of gas in Baltimore shall not exceed the sum of \$1.25 per 1,000 cubic feet. If at that price the clear yearly profit of the Consolidated Gas Company, and in this Act called "the Company," shall exceed 6 per cent. per annum on the capital stock, to be paid as a dividend to the holders of said stock, the excess beyond that sum to the extent of 1 per cent. per annum upon said capital stock shall from time to time be invested in dividend-paying securities, including the bonds of several companies, of which "the Company" is a consolidation, and the dividends and interest arising from such securities, in order that the same may accumulate at compound interest until the sum so accumulated shall equal in amount the bonded indebtedness of "the Company," when, or as soon thereafter as it shall become due, said bonded indebtedness shall be paid, and that all excess of clear yearly profits of "the Company," beyond a sum sufficient to pay a dividend of 6 per cent. per annum to the stockholders as aforesaid, and 1 per cent. per annum with which to pay the bonded indebtedness as aforesaid, shall become the property of the city of Baltimore, and to be paid into the treasury of the city. Section II. provides that the books of "the Company" shall be open to the Commissioners of Finance of Baltimore, who shall report to the Mayor of said city annually what amount of the clear yearly profits of "the Company" the said city shall be entitled to under the first section of the Act, and "the Company" and its officers shall offer all reasonable facilities for such inquiry, and refusing to do so shall forfeit its charter. Section III. provides, in consideration of the performance by "the Company," it shall have the exclusive right to make, distribute and sell illuminating and heating gas in Baltimore, for the period of 25 years from the passage of this Act. Section IV. provides that the ordinary remedies at law and equity shall apply to all questions arising under the Act. Section V. provides that the Act shall become effective on June 1st, 1890.

WE also understand that another measure will be introduced at this session of the Legislature, the gist of which is that the Consolidated Company shall pay to the city the sum of \$10,000 per annum in return for an exclusive franchise to furnish gas at the rate of \$1.25 per 1,000, for a period of 25 years.

MR. FRANK W. PENWELL, one of the purchasers of a recently-acquired controlling interest in the Danville (Ills.) Gas Company, also acts as President of the local Merchants Electric Light and Power Company.

ON January 28th Mr. E. C. Jones received his appointment as Assistant Engineer of the Boston Gas Light Company. This is in addition to the position as Superintendent of the North End Station. His office will be at the North End plant.

PETITIONS are being circulated in Massachusetts for signature, the intention of the movers therein being to ask the Legislature to pass a general law under which cities, towns and villages may operate lighting plants on municipal account.

JOHN H. ELLIOT has been elected President of the Keene (N. H.) Gas Light Company, Mr. Geo. M. Rossman continuing to act as Treasurer and Superintendent.

SOME time ago August Evering, of Vincennes, Ind., determined to satisfy an incredulous local public that coal existed in paying quantities underneath the soil of Vincennes. Undismayed by their adverse prophecies Evering's shaft eventually reached the coveted material, and the prophets changed their tune from ridicule to adulation. Having raised about 5,000 pounds of the coal to the surface, it was decided that the product should be sold publicly at auction on a given day; and when the hour was at hand almost all Vincennes was within sound of the auctioneer's voice. The first bid was \$20, which was followed by many others, or until the sum of \$100 was announced, at which figure the black diamonds were knocked down to Mr. George G. Ramsdell, who remarked that "although the material came high," he had "to have it."

Two days afterward the successful bidder succumbed to the advances of *la grippe*, from which we hope he will speedily emancipate himself.

GOSSIP in Belleville, Ills., is to the effect that negotiations were on foot which had for their object the consolidation of the Belleville Gas Light Company with the Brosius Electric Light Company, which now has the contract for the public lighting. Mr. Abend, who is largely interested in the Gas Company, was interviewed on the subject, and admitted the proposition had some advocates, but that he was opposed to it. He further said: "The Belleville Gas Company can furnish artificial lighting at a rate below that which could be made by any other company. I am in favor of reducing the rate for gas to \$1.50 per 1,000 from the first of April, and if the Council will afford the opportunity, I am in favor of submitting an offer of \$15 per post per annum for gas lighting, and to supply arc lamps west of Illinois street for \$75 per annum each."

WE do not see how the Council can very well overlook Mr. Abend's proposition, since the city is now paying the Brosius Electric Light Company \$120 per annum, each, for the arcs in service. The contract, however, under which this work is being performed—it is a three-year agreement—expires by limitation on April 30th. Perhaps it is from this circumstance that the Brosius Company's owners favor consolidation with the Gas Company; and likely it also is that Mr. Abend's opposition to the amalgamation is based on the fact that the Belleville Gas Company, having struggled with the competition of the past three years, ought not now to be used as an instrument for propping the waning fortunes of the local electricians.

THE plant of the Chillicothe (Mo.) Gas, Electric Light and Water Company has been sold by Receiver W. E. Gunby, for \$50,000, to Mr. Alexander G. Black, of New York. The latter will, in conjunction with his associates, make many improvements on the property.

THE proprietors of the Talladega (Fla.) Gas and Water Company have voted to bond the plant, the proceeds to be applied to extensions and betterments.

MR. HENRY W. BOND, attorney for the Laclede Gas Light Company, has requested Mayor Noonan for the necessary time wherein to prepare and file a written opinion on the bill recently passed by the Municipal Assembly reducing the price of gas from \$1.25 to 90 cents per 1,000. Mr. Bond contends that the city has no right to regulate the price of gas, since the Laclede Company has filed with the city its acceptance of the conditions imposed by the St. Louis Gas Company's amended or substitute charter.

TOWARD the close of January a hearing was given at the Chelsea (Mass.) City Hall, by the Board of Gas and Electric Light Commissioners, on the petition of J. B. Everdean and others, that the Chelsea Gas Company be obliged to supply incandescent electric lights on the basis of a meter system. Mayor Champlin opened for the petitioners in the statement that it cost the objector something to stand in antagonism to the Chelsea Gas Company, as it always had a monopoly of the gas business in the city. This rather poorly defined sentiment was followed by another equally absurd remark that as the Chelsea Gas Company was controlled or owned by non-residents no care was had by it in respect to the interests of the community, who had to pay unreasonable rates for light. After other partisans of the Mayor had echoed the sentiments of their leader, the Gas Company's representative replied that it was ready and anxious to introduce the meter system as soon as it was demonstrated that a reliable electric current meter had been put upon the market. The Commissioners reserved their decision.

IN view of the cogency of the Chelsea Company's implied objection to the meters now in the market we fail to see how Mayor Champlin and his "echoers" are to be appeased; for finally the Board cannot be expected to solve a problem off-hand that has caused and will cause many a sleepless night to the inventive division of the electrical fraternity.

THE American Gas Engine Company has been chartered at Chicago, by Messrs. Chas. Fellows, C. W. Annable and H. C. Johnson. Capital, \$200,000.

WRITING under date of Jan. 30, a correspondent says: "At the annual election of the Washington (O.) Gas Co. the following officers were elected: Pres., Morris Sharp; Sec. and Treas., Jerome Penn. Supt. Penns' annual reports show an increase over the half year, despite the competition of electric light, which displaced nearly half of the public lamps, and also took away quite a number of private consumers. The following are some of the percentages of increase: Gas used by private consumers, 18 per cent.; meters in service, 20 per cent.; gas stoves sold, 110 per cent.; gas engines in use, 100 per cent.; the company has leased a large room (18 ft. by 80 ft.) which will be used for an office and a workshop, from and after the first inst. The company expects to keep on hand a good supply of gas stoves and fixtures, and intends to make every possible effort to increase the use of gas for cooking and heating. The company's new dynamo was started last night. This gives it a capacity for 100 arcs, 51 of the latter being now in duty on the streets, and 25 are employed commercially. The company has a contract with the authorities for additional public lights, which will be placed this summer. The new bench of 5's put in last season worked satisfactorily, and another bench will be installed this summer.—J. P."

SECRETARY PENN has met with great success at Washington Court House, and his figures are vouchers that bear most eloquent testimony to the fact.

THE following Directors have been chosen by the proprietors of the Centralia (Ills.) Gas Company: Messrs. S. M. Warner, E. S. Condit, F. Kohl, G. L. Pittinger, Seymour Andrews and F. M. Tomkins.

By the breaking of an oil gauge on the apparatus in the generating room of the Macon (Ga.) Gas Company, an explosion occurred that threatened disastrous consequences. The coolness and bravery of Supt. Wilcox alone prevented a tremendous explosion.

THE authorities of Lincoln, Nebraska, have again appointed a "City Gas Inspector." This time his name is E. J. Flaherty.

AT the annual meeting of the Pulaski Gas Light Company of Little Rock, Ark., the following officers were chosen: President, Maj. John D. Adams; Treasurer, Charles F. Penzel; Secretary, Dean Adams. The officers and Messrs. John G. Fletcher and J. H. McCarthy are the Directors.

THE Trustees of the Consolidated Gas and Electric Light Company, of Westchester County, New York, are Chas. B. Ludwig, H. S. James, A. B. Gilbeck, H. M. Henderson and Leonard G. Levy.

THE City Council of Fort Worth, Tex., has completed the plan under which the city is committed to the operation of a municipal electric lighting plant. The Edison United Company is to make the installation, and the contract calls for a plant equal to the maintenance of 308 incandescent lamps (from 25 to 32 candle power each) and 42 arcs, candle power of latter to be 2,000 nominal. The Edison Company is to receive \$27,000, and the authorities estimate that "other expenses" will bring the total cost of the installation up to \$40,000.

JUDGE PHELPS, of the Burlington, Iowa, District Court, has refused to grant an injunction prayed for by the Burlington Electric Light and Power Company in restraint of the Burlington Gas Light Company. Plaintiff contended that as the Gas Company was operating an electric light supply, without authority of a franchise for such operation, it should be ordered to cease such supply, and that the city should at once remove the Company's poles from the streets. In denying the injunction, Judge Phelps said that the Gas Company could operate its electric plant without special franchise, as long as the "fact of its operation advanced the public good."

THE plant of the Batavia (N. Y.) Gas Light Company has been sold to certain parties, who were represented in the preliminary negotiations by Mr. W. C. Jacobs. It is probable that Rochester (N. Y.) capitalists

are those now in control, and we think they have secured a good property.

AT the annual meeting of the Hoosick Falls (N. Y.) Gas Light Company the following officers were elected: President, Walter P. Warren; Vice-President and Secretary, C. A. Cheney; Treasurer, Willard P. Parsons; Directors, Walter A. Wood, Walter P. Warren, C. E. Dudley Tibbets, C. W. Tillinghast and C. A. Cheney.

A. R. TAYLOR, on behalf of Daniel Donoghue, of St. Louis, has brought suit, in the sum of \$5,000, against the 1889 Board of Trustees of the St. Louis Gas Company. Complainant (who was an employee of the Company), on September 11, 1889, was injured by the caving in of the walls of a pipe trench, and this suit is to recover damages for injuries to person.

AT the annual meeting of the Youngstown (O.) Gas Company the following officers were chosen: President, George Tod; Secretary and Treasurer, P. T. Caldwell; Superintendent, Moses Coombs, Jr.; Directors, George Tod, C. H. Andrews, John C. Wick, W. J. Hitchcock and A. B. Cornell.

THE Mahoning Electric Light Company's proprietors also effected an organization identical with that of the Youngstown Gas Company.

AT the annual meeting of the San Francisco (Cal.) Gas Light Company Messrs. J. B. Crockett, Adam Grant, Levi Strauss, P. J. Donohue, D. J. Murphy, Ch. de Guigne and Geo. W. Prescott, were chosen Directors. In his annual report President Crockett reported that a greater quantity of water gas had been manufactured at the works in the last twelvemonth than in any previous year, though the manufacture of same was suspended during June, July and August, on account of a scarcity of oil supplies. The sales of gas were $37\frac{1}{2}$ millions cubic feet greater than in 1888. The number of street lamps lighted was 5,355, an increase of 175. There had been a net gain of 1,653 consumers. Much attention had been given to main renewals and extensions. Secretary Barrett's report showed net assets amounting to \$7,070,599. The cash in the treasury applicable to dividends is \$370,020, which would seem to show that shares in the Company are a bargain at present quotations. During the year 12 monthly dividends of 30 cents each per share were paid, the disbursements on this account amounting to \$360,000.

THE proprietors of the new Gas Company at Duquoin, Ills., have determined to sell gas at the following figures: For lighting, \$1.50 per 1,000; for cooking and heating, \$1.25 per 1,000.

AT the annual meeting of the Bristol (R. I.) Gas Light Company the following result was reached: President, Hon. R. S. Franklin; Sec., Treas. and Supt., J. Howard Manchester; Directors, Hon. R. S. Franklin, J. C. Swan, Col. Augustus P. Sherman, A. C. Church and J. H. Manchester.

ARGUMENT is now on in the Supreme Court of Pennsylvania, on the appeal of the Penn Gas Coal Company from a Common Pleas (Westmoreland county) decree refusing to grant a preliminary injunction against the Versailles Fuel Gas Company. The Penn Company is the owner of six tracts of land in Westmoreland county, with the right to remove all the underlying coal without liability for damage, and over the surface of this land the defendant proposes to lay its pipe lines, which will necessitate the leaving in place of about 50 acres of coal, of a value of at least \$30,000. It is also alleged that the pipe is being laid in a way dangerous to life and property. Decision is expected in a few days.

THE net gas rate at Cambridge, Mass., is to rule at \$1.60 per 1,000 from April 1st. This is a reduction of 15 cents.

THE Wallingford (Conn.) Gas Company is experimenting with a high power gas burner for street lighting purposes.

AT the annual meeting of the Malden and Melrose (Mass.) Gas Light Company the officers' reports were of the most encouraging nature. The increase in sendout over that for 1888 was much beyond the hopes of the shareholders. A quarterly dividend of 2 per cent. was declared, and the following officers were elected: President, Joshua T. Foster; Treasurer, Geo. D. Bill; Directors, J. T. Foster, Geo. D. Bill, A. M. Copp, D. V. Cox, J. H. Converse, L. P. True, E. S. Converse, D. W. Gooch, L. B. Hildreth and D. Russell.

MR. PETER ENGLISH, in connection with G. D. Lewis, visited Galesburg, Ills., with a view to "working up a healthy sentiment" for the establishment at the latter place of an opposition gas plant of the English process type. They believe that it will require \$100,000 of nominal capital to start the Galesburg venture, of which 50 per cent. is to be paid up, and they would like residents of Galesburg to take half of the sum required. They "point with pride" to the success of the English plant at Aurora, Ills., where a 24-candle gas is said to be sold at \$1.25 per 1,000. In reality, Aurora is far from satisfied with the English system of gas making and supply, and the complaints about poor service are frequent and loud. In the meantime Galesburg capitalists might do well to look over these facts prior to putting down their names in Mr. Lewis' subscription book. The city has a population of about 12,000, who are now consuming about 8 millions cubic feet of gas per annum, the rates for same being \$1.50, \$1.60 and \$1.80 per 1,000. At these rates the Company manages to earn a dividend. Start another Company, capitalized in \$100,000, then divide the profits arising out of the maximum sales noted, and where will shareholders in either concern receive a return? If Galesburg's capitalists are wise they will not only refuse to invest in this scheme, but will join together in keeping a franchise for an opposition company from all comers. Another company would put an end to Galesburg's opportunity in the future for cheap gas.

Influence of Temperature on Electric Tests.

The *Engineering Record* asserts that the question of temperature bears an important part in all tests of wire employed for electric transmission, since the resistance, both of metals and insulating materials, varies with the temperature.

Thus, we find it stated that the resistance of iron wire increases about 0.35 per cent. for each additional degree Fahrenheit, while the resistance of copper wire increases about 0.21 per cent. for each additional degree Fahrenheit. According to the Washburn & Moen Manufacturing Company, Dr. Mattheisen's report of the British Association Committee on Standards of Electrical Resistance states that hard iron varies between zero and 100° Centigrade (32° and 212° Fahrenheit) as much as 39.2 per cent., while German silver varies only 4.4 per cent. An alloy of silver with 31.4 per cent. of platinum varies only 3.1 per cent. For the best resistance coils some metal or alloy is used that is affected as little as possible by variations of heat.

It is necessary, for the sake of comparison, to fix a standard of temperature to which all tests shall be reduced. Cully gives this standard at 75°, a temperature high enough to exaggerate faults in insulation, yet not so high as to injure the material. Sprague says 60° F. is the most convenient for the adjustment of resistances. In this latitude, where for months a temperature so low as 60° is not reached, from 70° to 72° is found to be a more convenient scale, and it has been adopted by the Standards Department at Washington.

Luminous Paint.

Until recently the commercial manufacture of luminous paint has been confined to England, where a single factory turned out a small supply at a price of about \$3 a pound. This enormous cost seems to have prevented the use of the paint except as a curiosity. During the past year, however, a firm in Austria has found means to produce it and place it on the market at 50 cents a pound, or about one-sixth of the English price. Even at 50 cents a pound, a substance composed of roasted oyster shells and sulphur might be manufactured at a good profit, but at that price it is likely to come into extensive use. Wherever it can absorb light during the day it will give it forth at night, and it is said that a railway car in England, which has had its ceiling painted with it, was so brilliantly illuminated that one could see to read a newspaper in it during the darkest night, without other light. With all due allowance for the enthusiasm of early experimenters, there is no doubt that cars with ceilings so painted would be pleasant to ride in whether one could really see to read in them at night or not; and for making keyholes, stairways and sign-boards luminous, the paint would be invaluable. Its application to stairways is a particularly obvious one, and the Austrian manufacturers furnish a kind of wall paper on which the paint can be used to better advantage than on the bare plastering. The paper, which is of a leathery texture, is first treated with lime water, and then primed with a composition, furnished by the same firm. After this is dry, two thin coats of the luminous paint are applied, and the whole may then be varnished.



A. M. CALLENDER & CO.,

PROPRIETORS.

EDITOR—Jos. R. Thomas, C.E.

ASST. EDITOR—T. J. Cunningham.

MANAGER—C. E. Sanderson.

PUBLISHED ON EACH MONDAY OF THE YEAR AT

No. 42 Pine Street, New York.

TERMS:

SUBSCRIPTION—Three Dollars per annum, in advance. Single copies, 10 cents.

AGENTS.

NEW YORK.—AMERICAN NEWS CO., 39 and 41 Chambers Street.
PHILADELPHIA.—PRATT & CO., Corner Ninth and Arch Streets.
Germany.—B. WESTERMANN & CO., of New York.

MONDAY, FEBRUARY 10, 1890.

The Market for Gas Securities.

The market for city gas shares, in common with other stocks that suffered from the persistent hammering of those interested on the "short" side of the speculative turn, was inclined to dullness, although prices suffered very little. The truth is, that the quantity of Consolidated stock available for some time back for speculative purposes has been greatly curtailed in the last six months. The shares have found their resting place in the "strong boxes" of investors; hence, on a weak general market the effect is not exerted on quotations, but is shown in a cessation of stock offerings. On one day of the week only 5 shares were sold on Exchange. The bid figure to-day (Friday) is 96½, as against 96½ a week ago. Brooklyn shares are strong, notably Nassau, which is at 115 bid, with no offerings. Baltimore Consolidated is again at the advanced price of a fortnight ago, 54½-55. Chicago Trusts are strong at 47¼ bid. Bay State common is in demand at from 23-24½. We omitted to note in its proper place that Standard, of New York city, is again being inquired after. The common is quoted at 42-46, while the preferred rate may be returned at 83-86. Laclede common is weaker at 16½-17¼.

In connection with the Baltimore gas supply, well informed people think that an arrangement will be perfected by the Maryland Legislature under which the Consolidated Company will, in consideration of certain concessions to the city, be granted an exclusive right for a term of years.

Gas Stocks.

Quotations by Geo. W. Close, Broker and Dealer in Gas Stocks,

16 WALL ST., NEW YORK CITY.

FEBRUARY 10.

All communications will receive particular attention. The following quotations are based on the par value of \$100 per share.

	Capital.	Par.	Bid	Asked
Consolidated.....	\$35,430,000	100	96½	—
Central.....	500,000	50	—	—
“ Scrip.....	220,000	—	—	—
Equitable.....	4,000,000	100	120	125
“ Bonds.....	1,000,000	—	113	115

Harlem, Bonds.....	170,000	—	—	—
Metropolitan, Bonds....	658,000	—	116	118
Mutual.....	3,500,000	100	107½	—
“ Bonds.....	1,500,000	—	100	102
Municipal, Bonds.....	750,000	—	—	—
Northern.....	50	—	—
“ Bonds.....	150,000	—	—	100
Standard Gas Co.—				
Common Stock.....	5,000,000	100	42	46
Preferred.....	5,000,000	100	83	86
Yonkers.....	50	112	—
Richmond Co., S. I.	346,000	50	—	—
“ Bonds.....	20,000	—	—	—
Gas Co's of Brooklyn.				
Brooklyn.....	2,000,000	25	109	111
Citizens.....	1,200,000	20	68	70
“ S. F. Bonds... ..	320,000	1000	100	103
Fulton Municipal.....	3,000,000	100	122	—
“ Bonds....	300,000	—	100	105
Peoples.....	1,000,000	10	77	—
“ Bonds (5's).....	368,000	—	100	—
“ “ (6's).....	94,000	—	100	—
Metropolitan.....	1,000,000	100	93	96
Nassau.....	1,000,000	25	115	—
“ C'tfs.....	700,000	1000	100	112
Williamsburgh.....	1,000,000	50	119	122
“ Bonds... ..	1,000,000	—	108	112
Out of Town Gas Companies.				
Boston United Gas Co.—				
1st Series S.F. Trust	7,000,000	1000	—	92½
2d “ “ “	3,000,000	1000	71	72
Bay State Gas Co.—				
Stock.....	5,000,000	50	23	24½
Income Bonds.....	2,000,000	1000	—	—
Buffalo Mutual, N. Y... ..	750,000	100	90	95
“ Bonds... ..	200,000	1000	95	100
Citizens, Newark.....	1,000,000	50	155	160
“ “ Bonds.	45,000	—	—	—
Chicago Gas Trust.....	25,000,000	100	47¼	—
Chicago Gas Light. & Coke Co.—				
G't'd Gold Bonds	7,650,000	1000	93½	93¾
Equitable Gas & Fuel Co., Chicago, Bonds	2,000,000	1000	97	—
People's Gas and Coke Co., Chicago—				
1st Mortgage.....	2,100,000	1000	—	99
2d “	2,500,000	1000	—	97
Consumers Gas Light Co., Jersey City.....	2,000,000	100	15	25
Bonds.....	600,000	1600	80	—
Cincinnati G. & C. Co..	6,000,000	100	201	203
Consumers Toronto... ..	1,000,000	50	190	200
Central, S. F., Cal.....	80	80	90
Capital, Sacramento, Cal	58	—	—
Consolidated, Balt.....	11,000,000	100	54½	55
“ Bonds.....	6,400,000	—	107	107½
Hartford, Conn.....	750,000	25	102	108
Jersey City.....	750,000	20	186	190
Laclede Gas Light Co., St. Louis, Mo.—				
Common Stock....	7,500,000	100	16½	17¼
Preferred “	2,500,000	100	—	—
Bonds.....	9,034,400	1000	—	86
Louisville, Ky.....	2,570,000	50	125	130
Little Falls N. Y.....	50,000	100	—	100
“ Bonds	25,000	—	100	103
Montreal, Canada.....	2,000,000	100	200	208
Memphis (Tenn.) Gas... ..	750,000	100	48	51
“ Bonds.	240,000	100	103	—
New Haven, Conn.....	25	200	—
Oakland, Cal.....	35	35½	—
Peoples, Jersey City...	—	60	61
“ “ Bonds...	—	—	—
Paterson, N. J.....	25	99	102
Rochester, N. Y.....	50	99	100
Syracuse, N. Y.....	500,000	25	—	—
San Francisco Gas Co.	60	60½	—
San Francisco, Cal... ..	10,000,000	100	59¾	60
Washington, D. C.....	2,000,000	20	200	208
Wilmington, Del.,	50	88	90

Advertisers Index.

GAS ENGINEERS.	Page
Jos. R. Thomas, New York City	196
Wm. Henry White, New York City.....	199
Wm. Mooney, New York City.....	196
William Gardner, Pittsburgh, Pa.....	196
Fred. Bredel, N. Y. City.....	195
GAS AND WATER PIPES.	
Gloucester Iron Works, Phila., Pa.....	196
Mellert Foundry and Machine Co., Reading, Pa. (John Fox, Selling Agent, N. Y.).....	196
Ohio Pipe Co., Columbus, Ohio.....	196
M. J. Drummond, New York City.....	196
R. D. Wood & Co., Phila., Pa.....	198
Warren Foundry & Machine Co., New York City.....	196
Donaldson Iron Co., Emaus, Pa.....	196
Dennis Long & Company, Louisville, Ky.....	196
GAS WORKS APPARATUS AND CONSTRUCTION.	
James R. Floyd & Sons, New York City	199
Continental Iron Works, Greenpoint, L. I.....	199
Delly & Fowler, Phila., Pa.....	199
Kerr Murray Mfg. Co., Fort Wayne, Ind.....	187
Stacey Mfg. Co., Cincinnati, Ohio.....	199
Bartlett, Hayward & Co., Baltimore, Md.....	197
Morris, Tasker & Co., Limited, Phila., Pa.....	197
Davis & Farnum Mfg. Co., Waltham, Mass.....	151
R. D. Wood & Co., Phila., Pa.....	198
Bouton Foundry Co., Chicago, Ills.....	199
Smith & Sayre Manufacturing Co., New York City.....	198
Fred. Bredel, N. Y. City.....	195
United Gas Improvement Co., Phila., Pa.....	189
Henry Pratt & Co., Chicago, Ill.....	195
National Gas Light and Fuel Co., Chicago, Ills.....	190
Simpkin & Hillyer, Richmond, Va.....	184
PROCESSES.	
National Gas Light and Fuel Co., Chicago, Ills.....	190
Bartlett, Hayward & Co., Baltimore, Md.....	197
Wm. Henry White, N. Y. City.....	199
United Gas Improvement Co., Phila., Pa.....	189
Henry Pratt & Co., Chicago, Ill.....	195
The Fuel Gas and Light Improvement Co., N. Y. City.....	184
INCLINED RETORTS.	
Laclede Fire Brick Manuf'g Co., St. Louis, Mo.....	187
GASHOLDER TANKS.	
W. C. Whyte, New York City.....	190
J. P. Whittier, Brooklyn, N. Y.....	191
GASHOLDER PAINT.	
The Government Waterproof Paint Co., Boston, Mass.....	183
RETORTS AND FIREBRICK.	
J. H. Gautier & Co., Jersey City, N. J.....	194
B. Kreischer & Sons, New York City.....	194
Adam Weber, New York City.....	194
Laclede Fire Brick Manuf'g Co., St. Louis, Mo.....	194
Brooklyn Retort and Fire Brick Works, Brooklyn, N. Y.....	194
Borgner & O'Brien, Phila., Pa.....	194
James Gardner, Jr., Pittsburgh, Pa.....	194
Henry Maurer & Son, New York City.....	195
Chicago Retort and Fire Brick Co., Chicago, Ills.....	194
Baltimore Retort and Fire Brick Co., Baltimore.....	194
Oakhill Gas Retort and Fire Brick Co., St. Louis, Mo.....	194
SCRUBBERS AND CONDENSERS.	
G. Shepard Page, New York City.....	188
R. D. Wood & Co., Phila., Pa.....	198
REGENERATIVE FURNACES.	
Bartlett, Hayward & Co., Baltimore, Md.....	197
Fred. Bredel, New York City.....	194
Chicago Retort and Firebrick Co., Chicago, Ills.....	194
Wm. Henry White, N. Y. City.....	199
J. H. Gautier & Co., Jersey City, N. J.....	195
GAS GOVERNORS.	
Connelly & Co., New York City.....	191
Fred. Bredel, N. Y. City.....	195
Friedrich Lux, London, England.....	183
SELF-SEALING MOUTHPIECE DOORS.	
Smith & Sayre Mfg. Co., New York City.....	198
TAR AND CARBONIC ACID EXTRACTOR.	
Geo. Shepard Page, N. Y. City.....	152
PURIFYING MACHINES.	
C. & W. Walker, London, England.....	150
CEMENTS.	
C. L. Gerould & Co., Brooklyn, N. Y.....	194
GAS ENRICHERS.	
Standard Oil Co., Cleveland, Ohio.....	200

GAS METERS.

John J. Griffin & Co., Phila., Pa 202
 American Meter Co., New York and Philadelphia..... 203
 The Goodwin Gas Stove and Meter Co., Philadelphia, Pa... 203
 Helme & McIlhenny, Phila., Pa..... 203
 D. McDonald & Co. Albany, N. Y..... 203
 Nathaniel Tufts, Boston, Mass..... 202
 Maryland Meter and Manufacturing Co., Baltimore, Md.... 166
 John Hillen, Brooklyn, N. Y..... 203
 Bell & Jones, Philadelphia, Pa..... 202

EXHAUSTERS.

The P. H. & F. M. Roots Co., Connersville, Ind..... 186
 Smith & Sayre Manufacturing Co., New York City..... 198
 Willbraham Bros., Philadelphia, Pa..... 191
 Connelly & Co., New York City..... 191

GAS COALS.

Penn Gas Coal Co., Phila., Pa 201
 Perkins & Co., New York City..... 200
 Newburgh Orrel Coal Co., Baltimore Md..... 201
 Despard Coal Co., Baltimore, Md..... 201
 Chesapeake and Ohio R. R. Coal Agency, N. Y. City. 201
 Westmoreland Coal Company, Phila., Pa..... 201
 J. & W. Wood, New York City..... 200

CANNEL COALS.

Perkins & Co., New York City..... 200
 J. & W. Wood, New York City..... 200

VALVES.

Ludlow Valve Manufacturing Co., Troy, N. Y..... 192
 John McLean, New York City. 192
 Chapman Valve Manufacturing Co., Boston, Mass..... 192
 R. D. Wood & Co., Phila., Pa..... 198
 The P. H. & F. M. Roots Co., Connersville, Ind..... 186

GAS ENGINES.

Schleicher, Schumm & Co., Phila., Pa..... 204
 Clerk Gas Engine Co., Phila., Pa..... 192
 Van Duzen Gas Engine Co., Cincinnati, Ohio..... 192

ENGINES AND BOILERS.

Jarvis Engineering Co., Boston, Mass..... 191
 Ball Engine Co., Erie, Pa..... 183
 Westinghouse Machine Co., Pittsburgh, Pa..... 195

GAS LAMPS.

G. Shepard Page, New York City..... 156
 Standard Gas Lamp Co., Phila., Pa..... 184
 Welshach Incandescent Gas Light Co., Phila., Pa..... 185
 The Siemens-Lungren Company, Philadelphia, Pa..... 185

PURIFIER SCREENS.

John Cahot, New York City.. 192
 Bartlett, Hayward & Co., Baltimore, Md..... 192

GAS STOVES.

American Meter Co., New York and Philadelphia..... 193
 The Goodwin Gas Stove and Meter Co., Phila. Pa 168
 George M. Clark & Company, Chicago, Ills..... 185
 D. McDonald & Co., Albany, N. Y..... 203
 Maryland Meter and Manufacturing Co., Baltimore, Md. ... 166
 Bell & Jones, Philadelphia, Pa..... 202

STREET LAMPS.

J. G. Miner, Morrisania, New York City..... 184
 Bartlett Street Lamp Man'fg Co., New York City..... 184

BURNERS.

C. A. Gefrorer, Phila., Pa..... 200

STEAM BLOWER FOR BURNING BREESE.

H. E. Parson, New York City..... 192

PURIFYING MATERIAL.

Connelly & Co., New York City..... 191
 Friedrich Lux, London, England..... 183
 Edgewater Lime Works, Edgewater, N. J..... 183

COKE CRUSHER.

C. M. Keller, Columhus, Ind..... 201

ELECTRICAL APPARATUS.

Wm. Henry White, N. Y. City 199

SOLVENTS.

Maas & Waldstein, New York City..... 191

BOOKS, ETC.

Gerould's System Gas Bookkeeping..... 183
 1889 Directory. 1889 194
 King's Treatise 196
 Scientific Books. 202
 Management of Small Gas Works 192
 Gas vs. Electricity 148
 Practical Electric Lighting..... 191
 Electric Light Primer..... 191
 American Gas Engineer and Superintendents' Handbook... 201
 Digest of Gas Law..... 193
 Fuel and Its Applications 193

**POSITION WANTED.
 A Mechanical Engineer,**

Experienced in Gas Manufacture, wishes a position as Superintendent of a Gas Works. Best of references given and asked. Salary, \$1,200.

"MECHANICAL ENGINEER," care this Journal,
 765-1f or Box 972, West Bay City, Mich

Position Desired

By a man of practical experience in TESTING, SETTING, and REPAIRING METERS, STOVE WORK, COMPLAINTS, LAYING OF MAINS, SERVICES, ETC. Could manage a works of 20 millions. References A1.

766-2 "J. J. D.," care this Journal.

Position Wanted

As Superintendent or Assistant of a Gas Works, By a man who can give the best of references. Thoroughly understands the manufacture and distribution of gas and the construction of works. Address

765-5 "M.," care this Journal.

GAS WORKS FOR SALE.

A CONTROLLING INTEREST IN SEVERAL

Interior California Coal Gas Plants,

now paying handsomely, are offered on very reasonable terms. This is an exceptionally good opportunity for practical gas men of limited means, wishing to remove to a mild and healthful climate, to acquire an established and paying business. Particulars given and full investigation solicited.

SECRETARY, 123 Beale Street,

760-3 mos. San Francisco, Cal.

FOR SALE.

**A Complete Water Gas Plant.
 60,000 Cu. Ft. Daily Capacity.**

Fully equipped; all the latest improvements; includes Generator, Purifiers, and Holder. Can be removed to any part of the country, and set up at small cost. For further information apply to BRADFORD GAS LT. & HEATING CO., Dunkirk, N. Y.

FRIEDRICH LUX,

Ludwigshafen am Rhein and London.

**Lux Mass
 GAS GOVERNORS,
 Gas Balance.**

FOR SALE,

One 5-ft. Station Meter.

One Hydraulic Main (five sections), wrought iron, 22 by 24, with Bye-Pass on Dip-Pipes.

25 Valves, Stand-Pipes, 7-inch Mouthpieces and Lids, all complete, ready for use, to fit up five benches of 5's.

This apparatus is all in first-class condition.

Price, \$800, f.o.b. cars or boat, Poughkeepsie, N. Y.

Inquiries may be sent to this Office.

Fuel and Its Applications.

By E. J. MILLS, D.Sc. F.R.S., and F. J. ROWAN, C.E., assisted by others, including Mr. F. P. Dewey, of the Smithsonian Inst., Wash., D. C.

7 PLATES, AND 607 OTHER ILLUSTRATIONS. ROYAL OCTAVO, PAGES XX, 802. HANDSOME CLOTH, \$7.50.

A. M. CALLENDER & CO., 42 Pine St., N. Y.

GEROULD'S

System Gas Bookkeeping.

Approved and adopted by many of the prominent Gas Engineers of the Country.

Sample Sheets and Price-List furnished free on application to

L. P. GEROULD, - - Mendota Ill.

EDGEWATER LIME WORKS

Chas. F. McKenna, Proprietor.

SHELL LIME.

Lime by the Cargo for Gas Purification.

EDGEWATER, BERGEN CO., N. J.

Write for Testimonials and Prices.

GASHOLDER PAINT.

Use Only

THE GOVERNMENT WATERPROOF PAINT.

Proof against Ammonia, and Absolutely Waterproof. Send for Prices and Particulars.

THE GOVERNMENT WATERPROOF PAINT CO., 122 Milk Street, Boston, Mass.

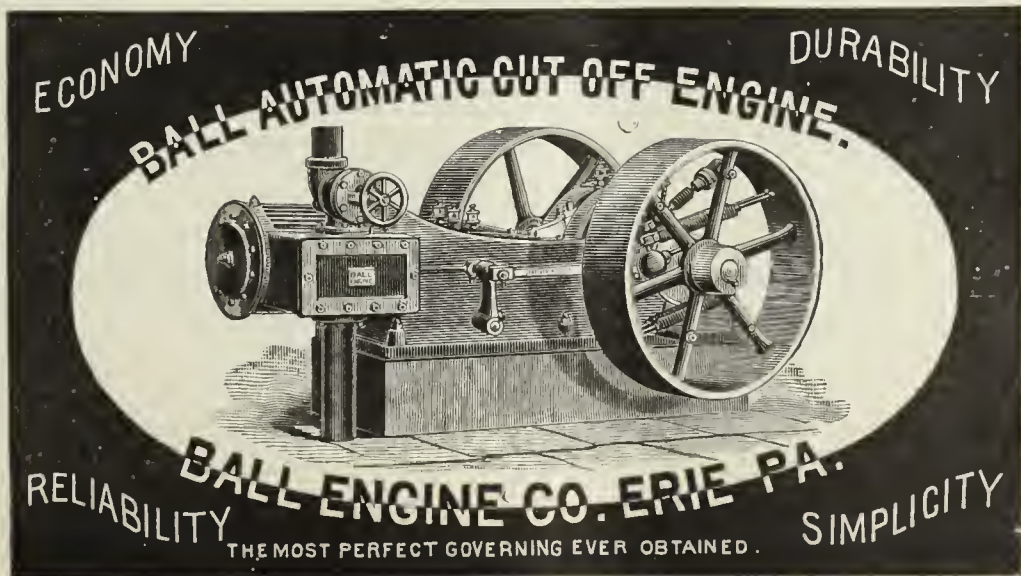

F. D. HARMON, PRES.

CHAS. C. ALLEN, SEC. AND TREAS.

P. W. MACKENZIE, CHIEF ENGR. & SUPT.

THE FUEL GAS AND LIGHT IMPROVEMENT CO.

OF AMERICA.

Owners of the RECENT Mackenzie Patents,

For the United States, England, Russia, France, Germany, Austria, and Canada,

No. 32 Park Place, New York City.

This SYSTEM is an ABSOLUTELY NEW DEPARTURE IN THE MANUFACTURE OF FUEL AND ILLUMINATING GAS. The COST OF GAS IN THE HOLDER by our System is at least THIRTY PER CENT. LESS than that made by any other process of the day.

The Gas is manufactured WHOLLY from LIQUID HYDROCARBONS, such as Lima, Penn, Crude, and Fuel Oils, Naphtha, etc. Neither PERISHABLE PIPES or other RETORTS, NOR THEIR EQUIVALENTS, are used.

Neither COAL, COKE, nor any other, HARD CARBONS enter into the manufacture or composition of the Gas, thereby requiring LESS LABOR THAN ANY OTHER METHOD.

The Gas contains neither SULPHUR nor other impurities, nor is there any resultant LAMPBLACK OR TAR RESIDUUM.

The Gas requires NO PURIFICATION whatever.

The FUEL GAS COSTS VERY MUCH LESS than PURE UNCARBURETED WATER GAS, and contains DOUBLE THE HEAT UNITS.

The APPARATUS is extremely SIMPLE, SUBSTANTIAL, and DURABLE, and consists of a Single Body with a capacity of ONE THOUSAND to ONE HUNDRED THOUSAND cubic feet per hour.

Works may be constructed to run by the CONTINUOUS or ALTERNATING method. If run continuously, the limited amount of Nitrogen present is neutralized by Carbon.

The Gas can be made of a HIGH GRADE for illuminating purposes, of a MEDIUM QUALITY for distribution for domestic purposes, and of a LOW GRADE for manufacturing uses.

Wherever Liquid Hydrocarbons can be had the MACKENZIE PROCESS WILL COMPETE IN PRICE AND SUPPLY ALL THE ADVANTAGES incidental to the use of NATURAL GAS.

This Company desires contracts for the construction of Plants, parts of Plants, Apparatus, Buildings, Holders, and Street Mains, for either of the above purposes, and will Lease or Purchase Works upon satisfactory terms.

Information will be promptly given regarding material required for production of Gas, actual cost of product, cost of works, etc.

Bartlett Street Lamp Mfg. Co.



MANUFACTURERS OF

Globe Lamps,

FOR

Streets, Parks, Public Buildings, Railroad Stations, etc.

LAMP POSTS

A Specialty.

Office and Salesroom,

40 & 42 COLLEGE PLACE, - - N. Y. CITY.

Gas Companies and others intending to erect Lamps and Posts will do well to communicate with us.

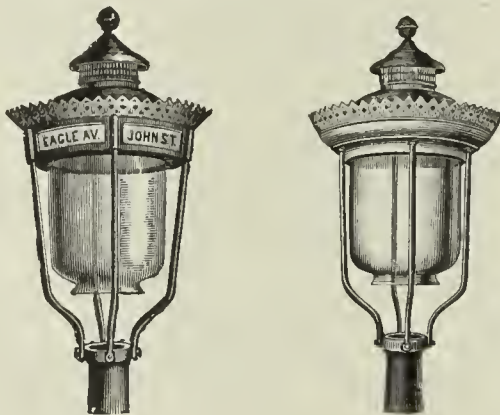

The Miner Street Lamps.

Jacob G. Miner,

No. 823 Eagle Ave., New York, N. Y.

6 PER CENT.

First Mortgage Bonds

ON GAS WORKS

SITUATED IN GROWING WESTERN TOWNS.

Principal and Interest Guaranteed.

INTEREST SEMI-ANNUALLY.

For sale by the undersigned, who will furnish all necessary information regarding them.

JOS. R. THOMAS, 42 Pine St., N. Y. City.

Simpkin & Hillyer

RICHMOND, VA.

MANUFACTURERS OF

Gas Works Apparatus

BENCH CASTINGS, CONDENSERS,

Scrubbers, Purifiers, Dry Center Seals,

FOUR-WAY VALVES, GAS VALVES,

SULPHATE OF AMMONIA APPARATUS,

TANKS, ENGINES, BOILERS,

PUMPS, ETC., ETC.

Plans, Specifications and Estimates furnished for new works, or, alteration of old works. Correspondence solicited. Works, Newport News, Va.



No. 29 Champion.

PHILADELPHIA.

NEW YORK.

CHICAGO.

STEPHEN A. MORSE, President.
GODFREY REBMANN, Vice-Pres.

EDWIN F. MORSE, Secretary.
CARLTON M. WILLIAMS, Treas.

STANDARD GAS LAMP CO.,

Main Office, 411 Cherry St. Factory, 1101, 1103, 1105 Frankford Av.

PHILADELPHIA, PA.

It is to the interest of Gas Companies and Cities to double the efficiency of the light on streets by using Dyott's Patent "CHAMPION" LAMPS. They save 50 per cent. over others in cost of repairs, are ornamental, and indestructible except by violence.

Our Patent System of Instantaneously Lighting Gas (without electricity), for Railroad Depots is unequalled.

Dyott's High Candle Power Burner is a very superior lamp where a concentrated and brilliant light is wanted in Hotels, Stores, Depots, etc.

Special Drawings furnished and Estimates cheerfully given, either from Architects, Engineers, or our Draughtmen's Plans.

We manufacture every description of Plain and Ornamental Lamps, Posts, Brackets, Clusters, etc. Correspondence solicited.

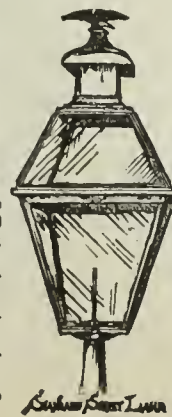

The Gordon Portico Lamp.

A successful Competitor of the Arc Electric Light for lighting Store Fronts, Show Windows, Depots, Railway Sheds, etc., etc.

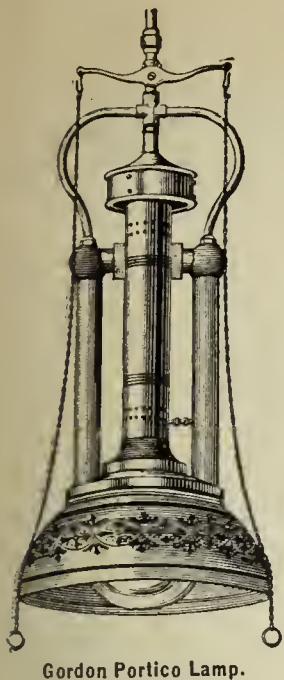

Gordon Portico Lamp.

The Gordon Street Lamp.

A Successful Competitor of the Arc Electric Light for lighting Streets, etc., etc.

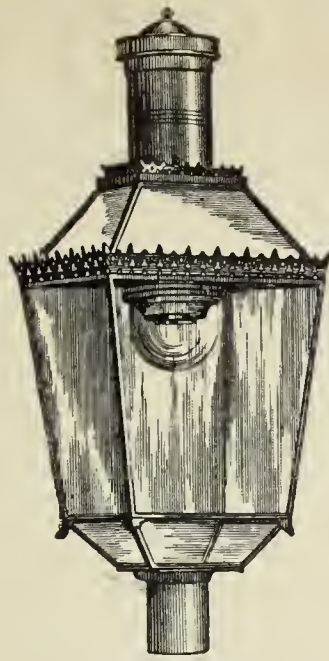

Gordon Street Lamp.

The Lungren Lamp.

A Successful Competitor of the Incandescent Electric Light for Interiors, etc. Is especially applicable for the lighting of Offices, Stores, Factories, Mills, Show Windows, Libraries, and all situations where an increased illumination is desired.

More than 25,000 Lungren Lamps are now in use. Testimonials, references, or any desired information will be cheerfully given.

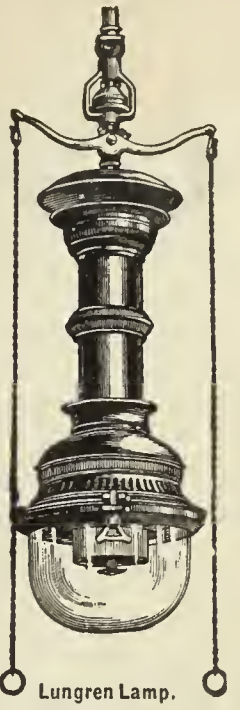

Lungren Lamp.

THE SIEMENS-LUNGREN CO., N.E. Cor. 21st St. & Washington Av., PHILADELPHIA.

WELSBACH SYSTEM OF Incandescent Gas Lighting.

OFFICE, DREXEL BUILDING, PHILA., PA.

At the Fall Session of the Board of Supervisors of Winnebago County, held at the County Court House, Oshkosh, Wis., Nov. 26, 1889, the report submitted by Mr. C. W. Cook, Chairman of the Committee on Public Buildings, recommending the use of the Welsbach Incandescent Gas Burner in the Buildings under their charge, was unanimously adopted, because of the extreme economy in the consumption of Gas and the superior character of the light obtained.

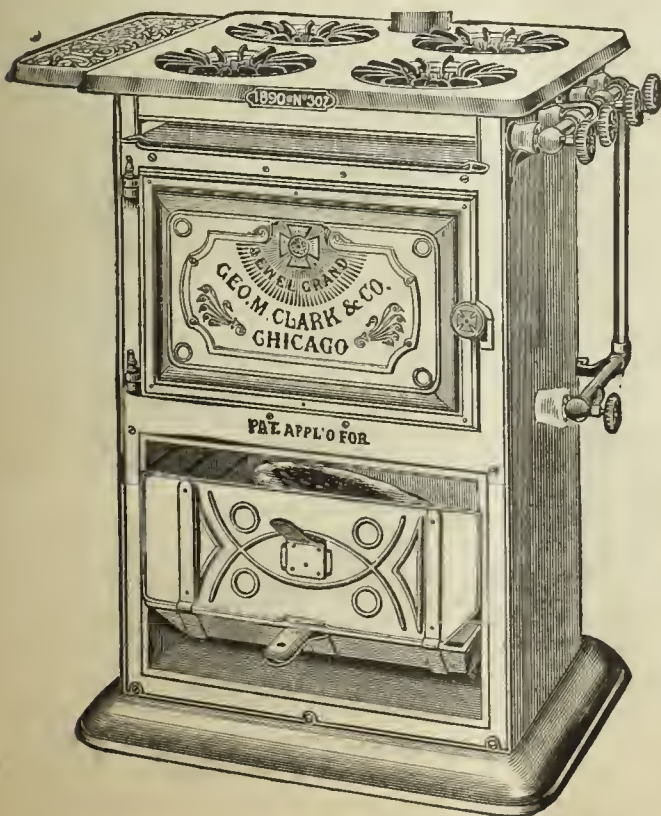

JEWEL GAS STOVES

MANUFACTURED BY

GEORGE M. CLARK & COMPANY,

Nos. 157 & 159 Superior Street, - - - Chicago, Ill.

EVERY CONCEIVABLE SIZE AND STYLE,

Ranging in Prices from \$1.50 to \$30.00.

WE USE NO GAS COCKS.

All Flames are Regulated by a Direct Needle Valve.

The JEWEL

IS THE

Only Well-Made Gas Stove on the Market.

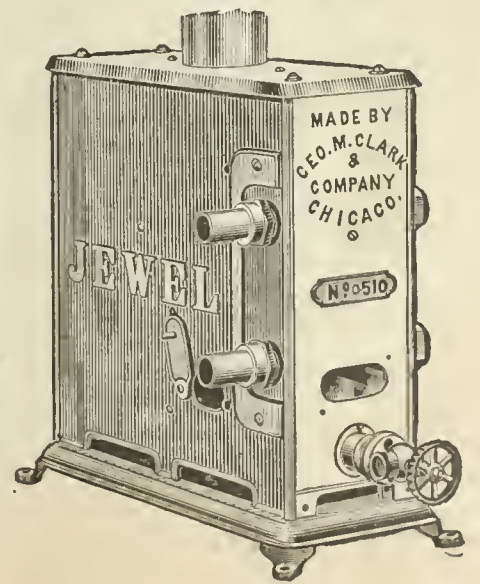

Write for our 1890 Catalogue and see for yourself.

ROOTS' GAS AND BYE-PASS VALVES.

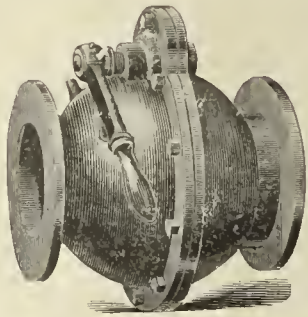

GAS VALVE

Quick Acting,
Simple,
Efficient, Durable.

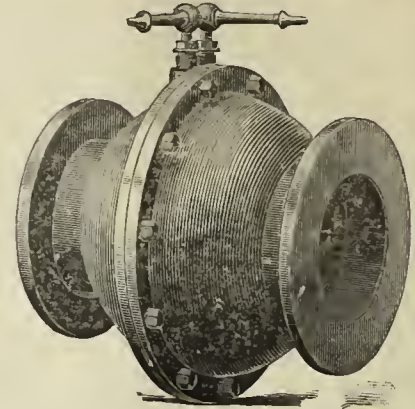

BYE-PASS VALVE.

Automatic Action,
Reliable,
Simple, Durable.

Thousands now in use and giving perfect satisfaction. Write for Catalogue and Prices.

ROOTS' NEW GAS EXHAUSTER.

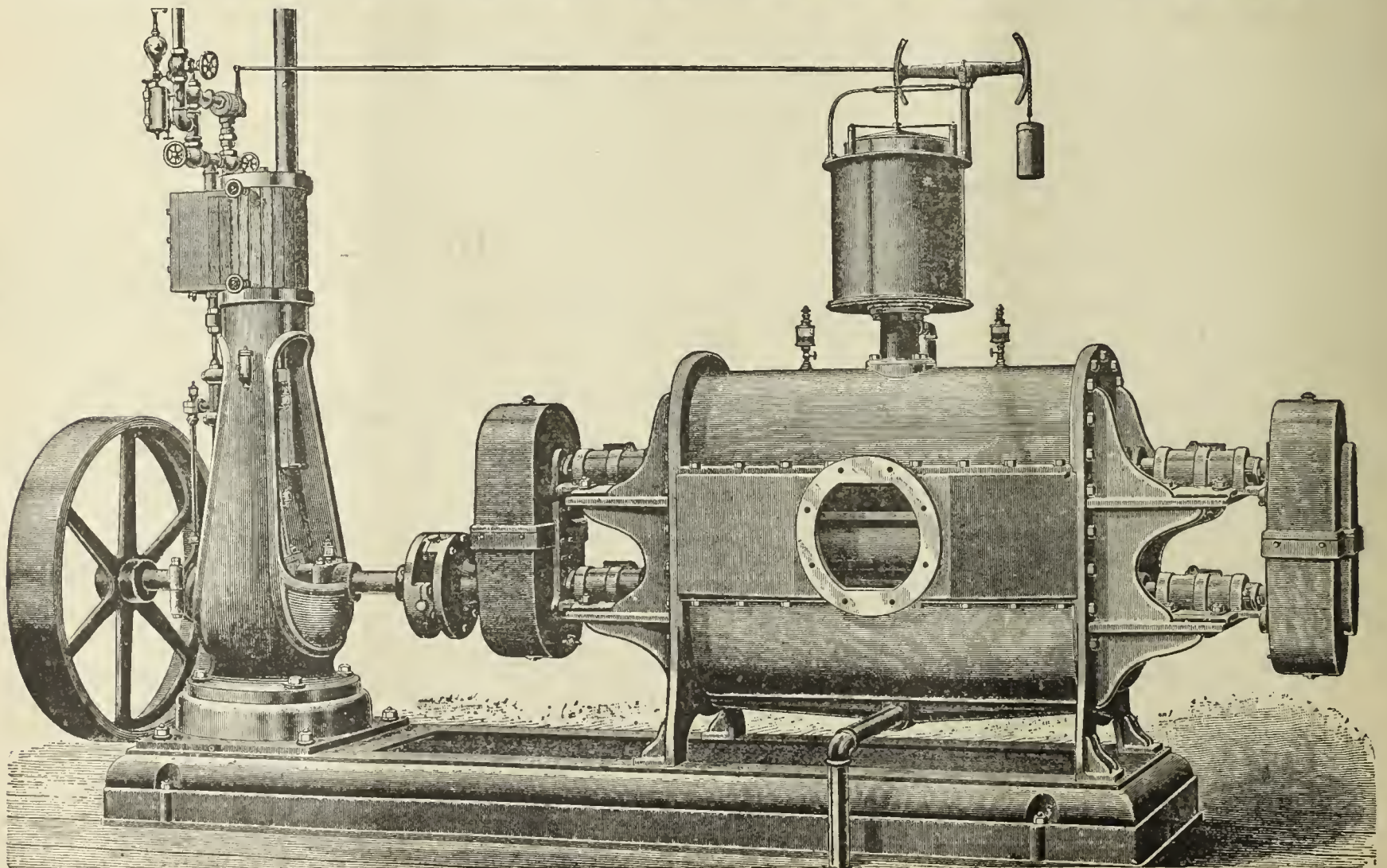

THE P. H. & F. M. ROOTS CO., Patentees and Manufacturers, CONNERSVILLE, IND.

S. S. TOWNSEND, Gen. Agt., 22 Cortlandt St., N. Y.

COOKE & CO., Selling Agts., 22 Cortlanat St., N. Y.

THIS SPACE
WILL BE
Occupied Next Month by the
KERR MURRAY MFG. CO.
FORT WAYNE, IND.
**GAS WORKS
APPARATUS
AND
HOLDERS.**

LACLEDE FIRE BRICK MANUFACTURING COMPANY,

ST. LOUIS, MO.

Exclusive Agents in the United States

FOR THE

Coze System of Inclined Retorts.

IT IS THE COMING BENCH
FOR MAKING COAL GAS.

*It will Save from 50 to
60 per ct. in Labor.*

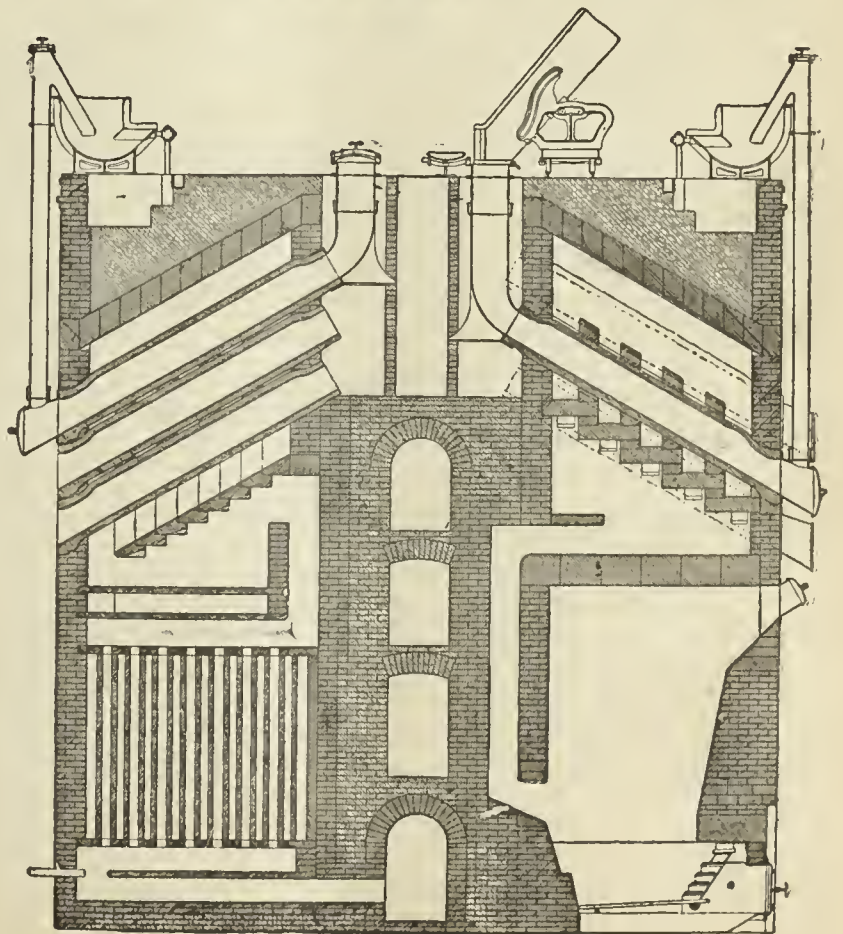
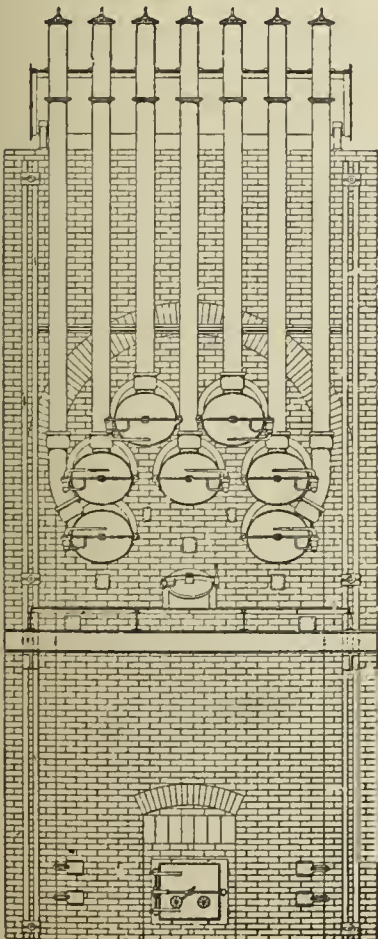

ESTIMATES AND PLANS FURNISHED BY THE

LACLEDE FIRE BRICK MFG. CO., ST. LOUIS, MO.

KIRKHAM, HULETT & CHANDLER, LIMITED.

PATENT "STANDARD" WASHER-SCRUBBERS
Erected and in course of construction at present date:

Capacity. Cubic feet per day.	Capacity. Cubic feet per day.	Capacity. Cubic feet per day.	Capacity. Cubic feet per day.
Altrincham..... 600,000	Dublin..... 3,000,000	LONDON—Continued.	Ober Schlesian..... 1,500,000
Adelaide..... 600,000	Dowlais..... 100,000	Shoreditch..... 2,500,000	Otto & Co.'s Coke Works..... 1,500,000
Aldershot..... 200,000	Douai..... 500,000	Pancras..... 1,500,000	Plymouth..... 2,000,000
Allegheny, U. S. A..... 1,000,000	Denton..... 500,000	"..... 1,500,000	Parramatta, N. S. W..... 100,000
Ashton-under-Lyne..... 1,250,000	Derby, U.S.A..... 350,000	Pimlico..... 2,000,000	Prescott..... 150,000
Amsterdam..... 1,500,000	Denver, "..... 500,000	Nine Elms..... 3,000,000	Providence, U.S.A..... 750,000
"..... 1,500,000	"..... 1,000,000	"..... 3,000,000	"..... 750,000
Annaberg..... 200,000	Dusseldorf..... 750,000	South Metropolitan Co:—	Plaueu..... 300,000
Arcahon..... 100,000	"..... 500,000	Greenwich..... 3,000,000	"..... 300,000
Animal Chareoal Co..... 200,000	Dumfries..... 250,000	Woolwich..... 400,000	Portsmouth..... 2,500,000
Altoona, U.S.A..... 350,000	Dunedin, N.Z..... 400,000	Vauxhall..... 3,000,000	"..... 2,500,000
Buxton..... 250,000	Darlington..... 1,250,000	"..... 3,000,000	Pittsburgh, U.S.A..... 1,500,000
Bradford..... 1,000,000	Detroit, U.S.A..... 750,000	Lea Bridge..... 300,000	Portland, "..... 560,000
"..... 1,250,000	Edinburgh..... 1,500,000	West Ham..... 1,500,000	Pawtucket, "..... 500,000
"..... 1,250,000	"..... 2,000,000	Leeds..... 2,000,000	Quebec..... 250,000
"..... 1,250,000	Enfield..... 300,000	"..... 3,000,000	Radeliffe..... 750,000
"..... 1,000,000	Essen..... 300,000	"..... 3,000,000	Ronen..... 250,000
"..... 1,000,000	Elbing..... 150,000	"..... 3,000,000	Ramsgate..... 1,000,000
"..... 3,000,000	Falmouth..... 150,000	"..... 2,000,000	Reigate..... 200,000
Bremen..... 150,000	Frankfort..... 300,000	"..... 3,000,000	Richmond, U.S.A..... 250,000
Baltimore, U.S.A..... 1,000,000	Farnworth..... 400,000	"..... 3,000,000	Roxbury, "..... 500,000
"..... 1,000,000	Fenton..... 400,000	"..... 3,000,000	Rnneorn Soap Co..... 20,000
"..... 1,000,000	Friedenshutte..... 500,000	"..... 2,000,000	Rockhampton, N. S. W..... 125,000
Balmain, N.S.W..... 125,000	Furth..... 400,000	Leominster..... 150,000	Richmond..... 1,500,000
Bishops Stortford..... 150,000	Freiburg..... 200,000	Leiden..... 560,000	Reading..... 2,000,000
Blackpool..... 400,000	Goole..... 250,000	"..... 600,000	Reichenbach..... 200,000
Brussels..... 1,250,000	Glossop..... 300,000	Liverpool..... 2,000,000	Salford..... 1,750,000
"..... 1,250,000	Guildford..... 300,000	"..... 2,000,000	"..... 1,750,000
"..... 750,000	Gloucester..... 1,250,000	"..... 2,000,000	"..... 1,750,000
"..... 1,250,000	Gera..... 300,000	"..... 2,000,000	Smethwick..... 750,000
Banbury..... 250,000	Grafton, N.S.W..... 100,000	"..... 2,000,000	Sydney, N. S. W..... 1,000,000
Birmingham..... 5,000,000	Grieg..... 300,000	"..... 3,000,000	"..... 1,000,000
Birkenhead..... 2,500,000	Georgetown, U.S.A..... 250,000	Lincoln..... 1,000,000	"..... 2,500,000
Blackburn..... 1,500,000	Gluckauf..... 200,000	"..... 600,000	"..... 50,000
Bochum..... 600,000	Hey wood..... 600,000	Lowell, U. S. A..... 1,000,000	"..... 50,000
Burrtisland..... 250,000	Hollywood..... 125,000	Louisville "..... 1,500,000	Sunderland..... 1,500,000
Boston, U.S.A..... 2,000,000	Huy..... 70,000	Long Eaton..... 500,000	St. Josephs, U.S.A..... 250,000
Brisbane..... 1,500,000	Harrow..... 250,000	Lilie..... 900,000	Spa..... 100,000
"..... 300,000	Harrogate..... 250,000	"..... 450,000	Sevenoaks..... 300,000
Burton-on-Trent..... 1,500,000	Halstead..... 150,000	"..... 750,000	St. Petersburg..... 2,000,000
Barcelona..... 350,000	Heilbronn..... 200,000	"..... 250,000	"..... 1,500,000
Barking..... 100,000	Havana, Cuba..... 750,000	"..... 250,000	St. Louis, U.S.A..... 2,000,000
Baerlien & Co..... 20,000	Hastings..... 1,500,000	"..... 250,000	"..... 2,000,000
"..... 20,000	Hnddersfield..... 300,000	Luckenwalde..... 330,000	"..... 1,000,000
Bombay..... 400,000	"..... 750,000	Liegwitz..... 300,000	Laclede..... 1,000,000
Buffalo, U.S.A., Mutual..... 750,000	"..... 1,500,000	Lincoln, U. S. A..... 250,000	Silesian Coal Co..... 600,000
"..... Citizen..... 500,000	Hof..... 200,000	Lawrence "..... 500,000	San Francisco, U.S.A..... 2,000,000
Brookline, U.S.A..... 500,000	Hampton Wick..... 500,000	Lynn "..... 300,000	"..... 2,000,000
Bergen..... 350,000	Heckmondwicke..... 500,000	Lyons..... 1,500,000	Sheepbridge Coal Co..... 40,000
Berlin..... 1,250,000	Haverfordwest..... 100,000	Maidstone..... 1,000,000	Stettin..... 200,000
Bonrnemouth..... 1,000,000	Halifax, N.S..... 350,000	Marseilles..... 1,500,000	Singapore..... 300,000
Bridgeport, U.S.A..... 500,000	Hamm..... 200,000	"..... 1,500,000	Sutton..... 500,000
Brunswick..... 300,000	Halle..... 400,000	Mons..... 500,000	Tonbridge..... 150,000
Beck & Co., St. Louis..... 100,000	Heidelberg..... 300,000	Malines..... 250,000	Tipton..... 400,000
Barmen Rittershausen..... 600,000	Hartford, U.S.A..... 1,000,000	Melbourne..... 1,500,000	Tottenham..... 1,000,000
Bexhill..... 125,000	Ilkeston..... 300,000	"..... 1,500,000	Toledo, U.S.A..... 750,000
Brooklyn, U.S.A..... 1,000,000	Inverness..... 2,000,000	"..... 1,500,000	Toronto..... 1,000,000
"..... Nassau..... 1,000,000	Ilkley..... 200,000	Manchester..... 2,500,000	Uxbridge..... 300,000
Brunner, Mond & Co..... 400,000	Ilford..... 100,000	Middleton..... 400,000	Valparaiso..... 500,000
Cheltenham..... 2,000,000	Kingston-on-Hull..... 400,000	Manley, N. S. W..... 100,000	West Bromwich..... 1,000,000
Cannes..... 200,000	Kidderminster..... 750,000	Minneapolis, U. S. A..... 750,000	Willenhall..... 250,000
Croydon..... 1,500,000	Kidsgrove..... 100,000	Magdeburg..... 300,000	Weston-super-Mare..... 500,000
Copenhagen..... 200,000	Konigberg..... 1,000,000	Memphis, U. S. A..... 750,000	Waltham..... 150,000
Clevedon..... 200,000	King's Lynn..... 300,000	Nottingham..... 1,250,000	Wormwood Scrubs..... 300,000
Columbus, U.S.A..... 500,000	LONDON:—	"..... 2,500,000	Williamsburg, U.S.A..... 600,000
Cincinnati, "..... 1,500,000	The Gaslight and Coke Co.:	"..... 2,500,000	Wellington..... 150,000
"..... 1,500,000	Beckton..... 1,250,000	"..... 2,000,000	Warwick..... 300,000
Chicago..... 3,000,000	"..... 1,250,000	"..... 1,500,000	Wheeling, U.S.A..... 500,000
"..... 1,000,000	"..... 1,250,000	"..... 2,000,000	Walker..... 300,000
"..... 1,000,000	"..... 1,250,000	Newport, U.S.A..... 430,000	Westgate..... 100,000
Chemnitz..... 1,000,000	"..... 1,250,000	Newmarket..... 150,000	Wilmington, U.S.A..... 500,000
Crewe..... 1,250,000	"..... 1,250,000	Newark, U.S.A..... 680,000	Windsor, N. S. W..... 100,000
Colonial Gas Works Co..... 100,000	"..... 1,250,000	Northfleet..... 200,000	Wolverton..... 100,000
Cadiz..... 300,000	"..... 2,500,000	New York, U.S.A..... 2,000,000	Wellington, N. Z..... 250,000
Charlottenburg..... 600,000	Silvertown..... 1,000,000	Nice..... 600,000	Whitchurch..... 175,000
Dudley..... 750,000	Bromley..... 2,000,000	Newcastle, N. S. W..... 200,000	Washington, U.S.A..... 2,000,000
Driffield..... 100,000	"..... 1,500,000	Numea, "..... 100,000	Wallasey..... 750,000
Dukenfield..... 500,000	"..... 1,500,000	Namur..... 250,000	Weimar..... 150,000
Dover..... 750,000	"..... 1,500,000	Newark..... 350,000	Wurzen..... 200,000
"..... 1,000,000	"..... 1,500,000	Oldbury..... 500,000	Worcester, U.S.A..... 750,000
Deal..... 200,000	"..... 2,000,000	Otley..... 200,000	Yeadon..... 500,000
Earby..... 1,500,000	"..... 1,500,000	Oswestry..... 250,000	Yeovil..... 250,000

SOLE AGENT FOR WESTERN HEMISPHERE,

GEO. SHEPARD PAGE, 69 WALL STREET, NEW YORK

THE UNITED GAS IMPROVEMENT CO.

DREXEL BUILDING, PHILADELPHIA.

OFFICERS:

WILLIAM W. GIBBS, President.

GEORGE PHILLER, Vice-President.

SAM'L T. BODINE, Gen'l Manager.

RANDAL MORGAN, Gen'l Counsel.

EDWARD C. LEE, Sec'y and Treas.

ALEX. C. HUMPHREYS, Gen'l Supt.

WALTON CLARK, Ass't Gen'l Supt.

H. H. EDGERTON, Chem. and Eng'r.

DIRECTORS:

GEORGE PHILLER,

THOMAS DOLAN

HENRY C. GIBSON,

WM. T. CARTER,

WILLIAM G. WARDEN,

SAM'L T. BODINE.

BUILDERS, LESSEES AND PURCHASERS OF

✻ GAS WORKS ✻

Orders solicited from Large Cities, Small Towns, Mills, Institutions, from all who want more Light for Less Money.

NATIONAL GAS LIGHT AND FUEL COMPANY,

No. 218 La Salle Street, Chicago.

THE SPRINGER SYSTEM

OF

Fuel and Illuminating Water Gas Works.

REFERENCES.

People's Gas Lt. & Coke Co..Chicago, Ill.
 Illinois Light, Heat & Power
 Co.....Chicago, Ill
 Elgin National Watch Co...Elgin, Ill.
 C. R. I. & P. R. R. Shops..Chicago, Ill.
 Decatur Gas Lt & Coke Co..Decatur, Ill.
 Niles Gas Light Co.....Niles, Mich.
 Newton Illuminating Co... Newton, Kansas.
 Wellington Light & Heat Co..Wellington, Kansas.
 Chippewa Falls Gas Lt. Co..Chippewa Falls, Wis.
 Elkhart Gas Lt & Coke Co..Elkhart, Ind.
 Madison City Gas Light Co.Madison, Wis.
 South Bend Gas Light Co..South Bend, Ind.
 Sheboygan National Gas Co.Sheboygan, Wis.
 Salina Gas Light Co.....Salina, Kansas.
 The Rathbun Co.....Deseronto, Prov.Ont.
 Jefferson City Gas Lt. Co..Jefferson City, Mo.
 Mankato Gas Light Co....Mankato, Minn.
 Lima Gas Light Co...Lima, Ohio.

Minneapolis Gas Light and
 Coke Co.....Minneapolis, Minn.
 Bellevue Water and Fuel }
 Gas Light Co..... } Bellevue, Campbell
 County, Ky.
 Bucyrus Gas Lt. & Fuel Co.Bucyrus, Ohio.
 Morris Gas Co.....Morris, Ill.
 Los Angeles Gas Co.....Los Angeles, Cal.
 San Diego Gas Fuel & Elec-
 tric Lt. Co.....San Diego, Cal.
 Sioux Falls Gas Co.....Sioux Falls, Dak.
 Dakota Gas and Fuel Co..Grand Forks, Dak.
 St. Johns Mutual Gas Co...St. Johns, Mich.
 Stillwater Gas Light Co...Stillwater, Minn.
 St. Paul Gas Light Co....St. Paul, Minn.
 Emporia Electric and Gas
 Light Co.....Emporia, Kas.
 Van Wert Gas Light Co...Van Wert, Ohio.
 Lansing Gas Light Co....Lansing, Mich.
 San Francisco Gas Lt. Co...San Francisco, Cal.

Shelbyville Gas Light Co...Shelbyville, Ind.
 Great Falls Gas Light Co..Great Falls, N. H.
 Belleville Gas Co.....Belleville, Ontario
 Rochester Lt. and Fuel Co..Rochester, Minn.
 Northwestern Gas Light and
 Coke Co.....Evanston, Ill.
 Lincoln Gas Light Co....Lincoln, Neb.
 Davenport Gas Light Co...Davenport, Iowa.
 Municipal Gas Co.....Albany, N. Y.
 Alliance Gas Light Co....Alliance, Ohio.
 New Gas Light Co.....Janesville, Wis.
 Chicago Gas Lt. & Coke Co., Chicago, Ill.
 Joliet Gas Co.....Joliet, Ills.
 Superior Light & Fuel Co..Superior, Wis.
 Kewanee Gas Light Co...Kewanee, Ill.
 Aberdeen Light & Fuel Co..Aberdeen, So. Dak.
 Pierre Light and Fuel Co..Pierre, So. Dak.
 *Standard Gas Light Co...New York City.
 *Carlinville Gas Light Co..Carlinville, Ill.

* Building.

GUARANTEED ESTIMATES of Cost of Gas Furnished on Application.

GASHOLDER TANK CONSTRUCTION, ETC.

Gas Companies and others about to erect Gasholders will find it profitable to consult
 W. C. Whyte, who for over 30 years has made a specialty of

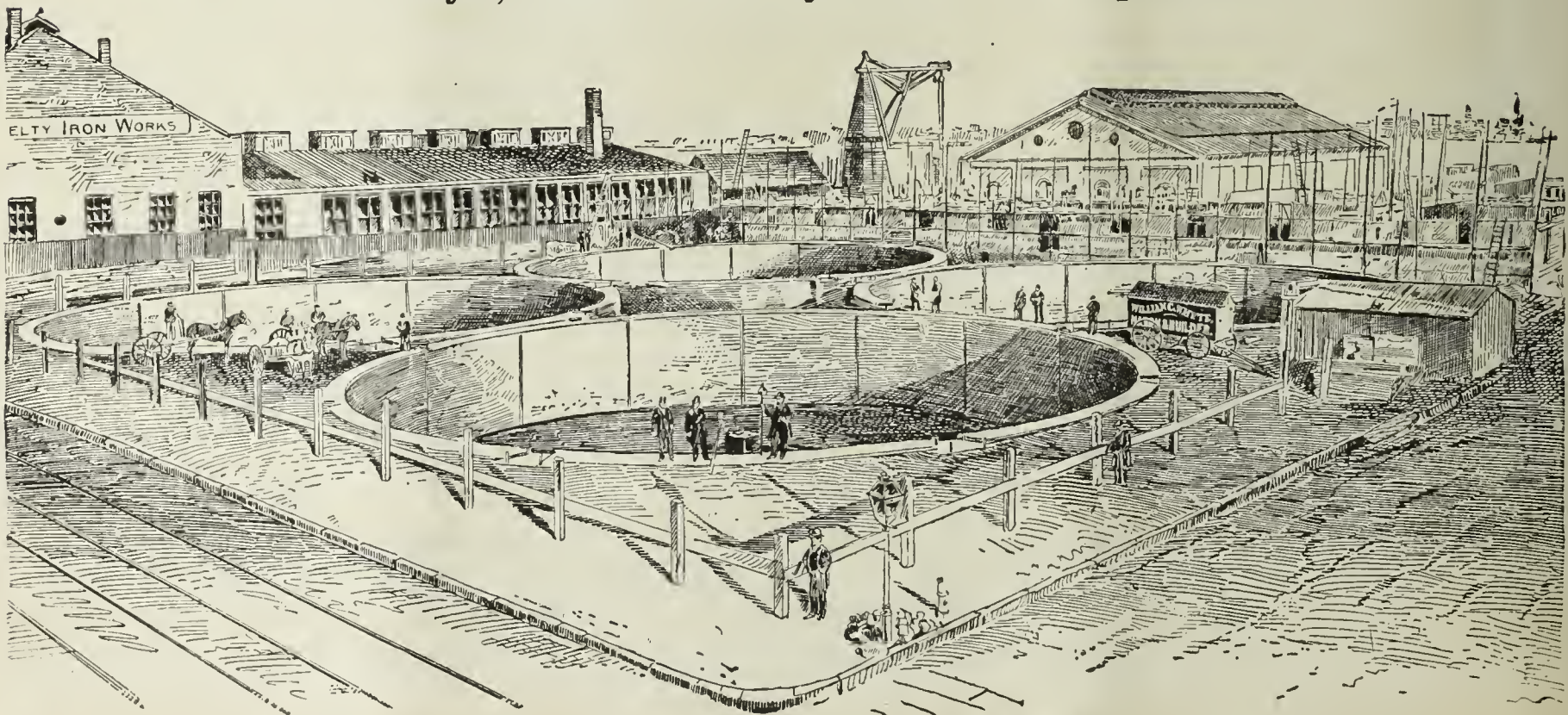

Tank Excavation and Mason Work.

Fifty Tanks now in operation show the sort of work done. Address

W. C. WHYTE, - No. 15 Cortlandt Street, N. Y. City.

CONNELLY & CO.,

SOLE MANUFACTURERS OF THEIR PATENTED SPECIALTIES.

"IRON SPONGE."

Saves money, saves labor, and is the most efficient purifying agent ever offered as a substitute for lime. Now used *in every State in the Union*, and purifying daily over *thirty-five million cubic feet*. Should be used in every gas works. Its own saving will pay for it many times over.

AUTOMATIC GOVERNOR.

Has been on the market but *three years*, and in that time has been introduced *more generally* than any invention ever designed for use in gas works. Over *two hundred* of them now in use. Sensitive; reliable; perfectly automatic; reduces leakage; satisfies consumers, and gives great relief to the Manager. No gas works is *complete* without one of these machines.

STEAM JET EXHAUSTER.

Designed particularly for small works. Combines Exhaust Tube, Steam Governor Gas Compensator, and Bye-Pass Valves in the most compact form possible; occupies but little space; uses very little steam; operated by ordinary workmen; saves formation of carbon in retorts; increases yield 10 to 15 per cent. Specially adapted for *mixing air* with oil gas. *No works* too small to use them profitably.

Prices given on all our specialties *delivered at any point in the United States*. Correspondence solicited.

CONNELLY & CO., No. 111 Broadway, New York City.

WILBRAHAM GAS EXHAUSTER

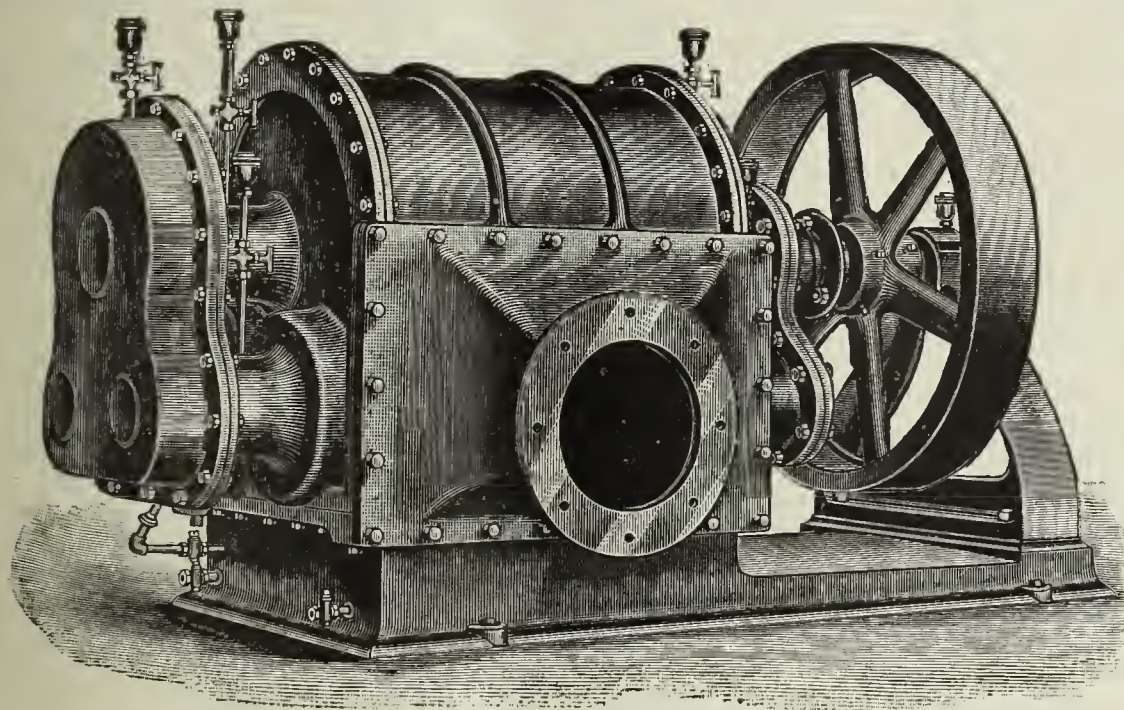

WILBRAHAM BROS.,
PHILADELPHIA, PA.

JARVIS ENGINEERING CO.,

61 Oliver St., Boston, Mass.

CONTRACTORS FOR ERECTING

COMPLETE STEAM OUTFITS FOR ELECTRIC LIGHTING STATIONS.

Steel Boilers set with Jarvis Pat. Boiler Setting

To burn **COKE SCREENINGS** for Fuel.

ARMINGTON & SIMS CO. ENGINES,

Belting direct to Dynamos, without using Shafting.

SEND FOR CIRCULARS.

REFERENCES.—Charlestown Gas & Electric Light Co., Charlestown, Mass.; Schenectady Gas & Electric Light Co., Schenectady, N. Y.; Brookline Gas Co., Brookline, Mass.

Practical Electric Lighting

By A. BROMLEY HOLMES, A.M.I.C.E.

With 87 Illustrations. Third Edition. Price, \$1.00.

Electric Light Primer.

By CHARLES L. LEVEY.

A simple and comprehensive Digest of all the most important facts connected with the running of the Dynamo and Electric Lights, with Precautions for Safety, etc.

Price, 50 cents.

A. M. CALLENDER & CO., 42 Pine St., N. Y.

(Patented.)

IMPORTANT!

(Patented)

NEW SOLVENT FOR GAS PIPE DEPOSITS.

Economical and Effective.

MAAS & WALDSTEIN, 44 Trinity Place and 81 Greenwich St., N. Y.

Gasholder Tanks & Gas Works Masonry Complete.

PLANS PREPARED AND ESTIMATES FURNISHED AT SHORT NOTICE.

J. P. WHITTIER, - - 499 Wythe Av., Brooklyn, N. Y.



CHAPMAN VALVE MANUFACTURING CO.,

MANUFACTURERS OF

Valves and Gates for Gas, Ammonia, Water, Etc.

Also, Gate Fire Hydrants With and Without Independent Nozzle Valve. All Work Guaranteed.

WORKS & GEN'L OFFICE:
Indian Orchard, Mass.

TREASURER'S OFFICE:
72 Kilby & 112 Milk Sts, Boston, Mass.

LUDLOW VALVE MFG. CO.



OFFICE AND WORKS,

938 to 954 River Street and 67 to 83 Vail Av.,
TROY, N. Y.

Parson's Steam Blower,

FOR IMPROVING BAD DRAUGHT IN BOILERS, AND FOR BURNING BREEZE OR OTHER WASTE MATERIAL.

PARSON'S TAR BURNER,

FOR UTILIZING COAL TAR AS FUEL.

PARSON'S AIR JET TUBE CLEANER,

FOR CLEANING BOILER TUBES.

These devices are all first-class. They will be sent to any responsible party for trial. No sale unless satisfactory. Manufactured by the WATERTOWN STEAM BLOWER COMPANY.

H. E. PARSON, Supt., 33 & 35 Liberty St., N.Y.

MILLS' REVERSIBLE LIME TRAY,

AND

WOODWORK

Of Every Description

NEEDED BY GAS WORKS.

SEND FOR CIRCULAR AND PRICE LIST TO

BARTLETT, HAYWARD & CO.,

Pratt and Scott Streets, Baltimore, Md.

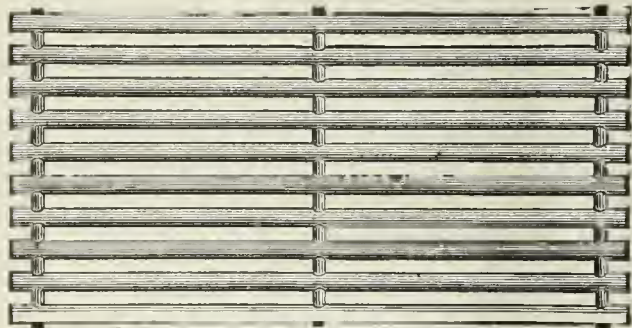

Hydraulic Main Dip Regulators, also
Check Valves, Foot Valves, Yard-
wash and Fire Hydrants.
Send for Circulars.

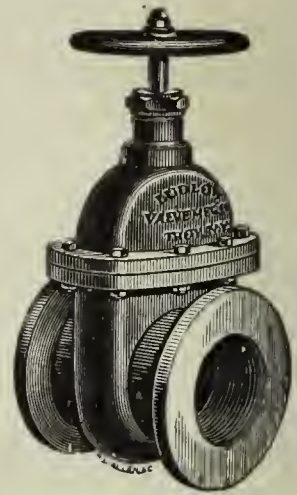

Valves.—Double and Single Gate, 1/2 in. to
48 in., outside and inside Screws. Indica-
tor, etc., for Gas, Water, Steam, and Oil.
Send for Circulars.

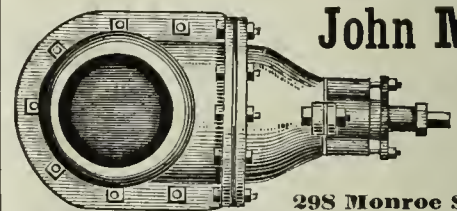

John McLean

Man'facturer

**GAS
VALVES.**

298 Monroe Street, N. Y.

SPECIAL TRAYS FOR IRON SPONGE OR OXIDE OF IRON.

CHURCH'S TRAYS A SPECIALTY.

REVERSIBLE—STRONGEST—MOST DURABLE—MOST EASILY REPAIRED.

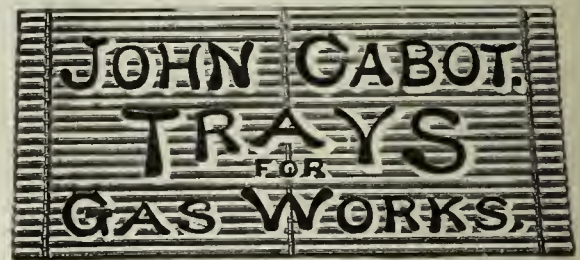

306-310 ELEVENTH AVENUE, NEW YORK.

WE ALSO MAKE THE CHEAPEST AND STRONGEST
REVERSIBLE BOLTED TRAYS IN THE MARKET.

**VAN DUZEN
GAS & GASOLINE ENGINE**

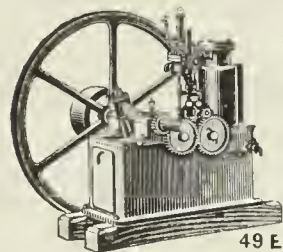

OPERATED with COAL
and OTHER MANUFAC-
TURED GASES AND
GASOLINE.

**RELIABLE AND
ECONOMICAL.**

Fully Warranted

VAN DUZEN

Gas & Gasoline Engine Co.

49 E. 2d St., Cincinnati, O.

A. MacKinnon Machine Co., Agts., 22 Warren St., N.Y.

**The Management of Small
Gas Works.**

BY C. J. R. HUMPHREYS.

Price, \$1.

Orders to be sent to **A. M. CALLENDER & CO.,**

42 PINE STREET, NEW YORK.

THE CLERK GAS ENGINE CO.,

Main Office, 1012, 1014, 1016, 1018 Filbert St., Philadelphia, Pa.

WM. W. GOODWIN, Prest.

E. STEIN, Sec.

S. LEWIS JONES, Asst. Sec.

A. J. DOTY, Supt.

The utility and convenience of the Gas Engine being no longer an open question, it only remains now for intending purchasers to select the BEST. We claim for the CLERK GAS ENGINE that it is equal to any other manufactured as regards steadiness in running, simplicity, and ease of keeping in repair, and that it gives the greatest amount of power for the least money (both in first cost and expense of running) of any engine made. In support of this claim we refer to the test of the Gas Engines made under the direction of the American Institute of New York, in December, 1885, and heretofore published in these columns. These engines are especially adapted for continuous running under heavy loads, and we can refer to Engines which have run 22 hours a day for months at a time

Made in Sizes of 5 10 15 20, and 25 Horse Power. All Engines Guaranteed for One Year.

GAS STOVES.

GAS METERS.

GAS STOVES.

THE AMERICAN METER CO.,

MANUFACTURERS OF

GAS METERS, Station Meters,

METER PROVERS, PHOTOMETERS,
PRESSURE GAUGES OF ALL KINDS,



Standard 3 Diaphragm Dry Meter

AND

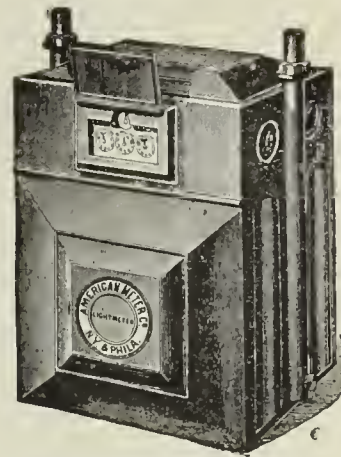

Standard 2 Diaphragm Dry Meter.

Apparatus for Testing the Quantity and Quality of Gases.

GAS STOVES FOR HEATING AND COOKING

Sole Agents in the United States for

Verity's Patent Gas Fires.

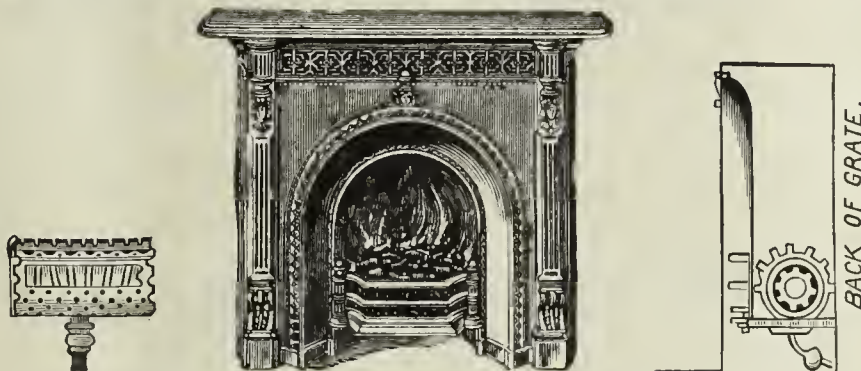

Circulars and Price Lists on Application.

MANUFACTORIES,

508 to 514 West Twenty-second St., N. Y.

Arch and Twenty-second St., Phila

Nos. 244 & 246 North Wells Street, Chicago, Ill.

AGENCIES,

No. 177 Elm Street, Cincinnati, Ohio.

No. 222 Sutter Street, San Francisco, Cal

No. 810 North Second Street, St. Louis, Mo.

GAS STOVE SHOW ROOMS, No 242 Sixth Avenue, New York City.

RETORTS AND FIRE BRICK.

RETORTS AND FIRE BRICK.

RETORTS AND FIRE BRICK.

J. H. GAUTIER & CO..
CORNER OF
GREENE AND ESSEX STREETS,
JERSEY CITY, N. J.

MANUFACTURERS OF
**Clay Gas Retorts,
Gas House Tiles,
Fire Bricks, Etc. Etc.**
Ground Clay, Fire Brick and
Fire Sand in Barrels,

J. H. GAUTIER. C. E. GREGORY. C. E. GAUTIER.

BROOKLYN
Clay Retort & Fire Brick Works,
(EDWARD D. WHITE & CO.)
Manufacturers of Clay Retorts, Fire Brick,
Gas House and other Tile.
VAN DYKE, ELIZABETH, RICHARDS & PARTITION STS.
Office, 88 Van Dyke St., Brooklyn, N. Y.

LACLEDE FIRE BRICK MFG. CO.,
MANUFACTURERS OF
Fire Brick, Gas Retorts,

AND
ST. LOUIS STANDARD SEWER PIPE.
Blast Furnace and Cupola Linings, every description of Fire
Clay Material, Fire Clay Flue Linings, Chimney Tops
Dry Milled and Crude Fire Clays, etc.
OFFICE AND DEPOT
901, 903, and 905 Pine Street,
ST. LOUIS, MO.

ESTABLISHED IN 1845.

B. KREISCHER & SONS,
OFFICE FOOT OF HOUSTON ST., E. R., N. Y.
Gas Retorts,
TILES, FIRE BRICK.
AND EVERYTHING IN THE FIRE CLAY LINE.

MANHATTAN
FIRE BRICK & ENAMELLED CLAY
RETORT WORKS
ADAM WEBER.

**CLAY GAS RETORTS
AND RETORT SETTINGS**
FIRE BRICKS, TILES, ETC.,
Office and Works, 15th Street and Avenue C., N. Y.

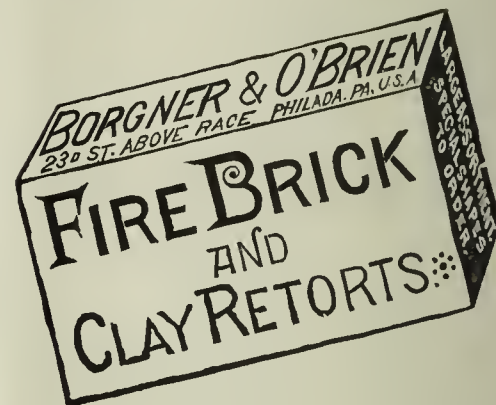

—ESTABLISHED 1864.—

Works,
LOCKPORT STATION, PA.

JAMES GARDNER, JR.,

Office, Rooms 19 & 20, Lewis Block,
PITTSBURGH, PA, P. O. Box 373.

Successor to WILLIAM GARDNER & SON.

Fire Clay Goods for Gas Works.

H. A. NORTON, No. 4 CENTRAL STREET, BOSTON, MASS., Agent for the New England States.

GEO. C. HICKS, CHICAGO CHAS. A. REED,
Prest. Sec. & Treas.
Retort and Fire Brick Co.,
MANUFACTURERS OF
Fire Clay Goods of all Kinds,
AND BEST QUALITY ONLY.

Regenerative Furnaces & Water Gas Goods.
45th St., Clark to La Salle, Chicago.

GEROULD'S IMPROVED RETORT CEMENT.
A Cement for patching retorts, putting on mouthpieces, and
making up all bench-work joints. This Cement is mixed ready
or use. Economic and thorough in its work. Fully warranted
o stick. For recommendations and price list address

C. L. GEROULD & CO.,
5 & 7 Skillman St., Brooklyn, N. Y.
Western Agent, H. T. GEROULD, Mendota, Ill.

Parker-Russell
Mining and Mfg. Co.,

CITY OFFICE: { Mermod-Jaccard Bldg., Rooms 307 & 308,
Broadway and Locust Street, St. Louis, Mo.

PROPRIETORS OF THE
OAKHILL GAS RETORT & FIRE BRICK W'KS

Our immense establishment is now employed almost entirely in
the manufacture of materials for

GAS COMPANIES.
We have studied and perfected three important points. Our re-
torts are made to stand changes of temperature, the strongest
heats of the furnace, and the abrasion of feeding and emptying.
We furnish and build Half-Depth or Full
REGENERATOR FURNACES
of different kinds and most approved styles.
Correspondence solicited.

THOS. SMITH, Prest. AUGUST LAMBLA, Vice-Prest. & Supt.

BALTIMORE
RETORT & FIRE BRICK CO.

MANUFACTORY AT
LOCUST POINT, BALTIMORE, MD.

Clay Retorts, Blocks & Tiles,
FIRE BRICK, FIRE CLAY,
AND FIRE CEMENT.

Red and Buff Ornamental Tiles and Chim-
ney Tops. Drain and Sewer Pipe (from
2 to 30 inches). Baker Oven Tiles
12x12x2 and 10x10x2.
WALDO BROS., 88 WATER ST., BOSTON, MASS
Sole Agents the New England States.

1889 DIRECTORY 1889

OF THE GAS LIGHT COMPANIES of the UNITED STATES & CANADA.

Price, \$3.00.

A. M. CALLENDER & CO., No. 42 Pine Street, N. Y. City.

HENRY MAURER & SON,
 (ESTABLISHED 1856.)
EXCELSIOR FIRE BRICK & CLAY
RETORT WORKS
 WORKS, Perth Amboy, N. J.
 OFFICE, 418 to 422 East 23d St., N. Y.
Clay Gas Retorts,
BENCH SETTINGS,
 Fire Brick, Tiles, Etc.

FLEMMING'S
Generator-Gas Furnace

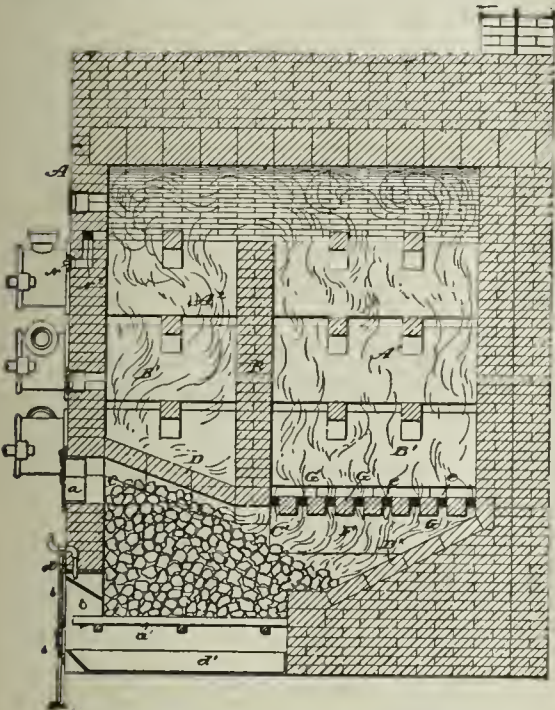

Materials furnished and Benches erected by

J. H. GAUTIER & CO., - Jersey City, N. J.

Address as above, or D. D. FLEMMING, Jersey City, N. J.

FRED. BREDEL,
 CONTRACTOR FOR THE COMPLETE
Erection and Equipment of Gas Works.
 SOLE PROPRIETOR OF THE
KLOENNE PATENTS
 FOR NORTH AMERICA.

REGENERATIVE FURNACES.

(900 Retorts are now fired in America by the Kloenne-Bredel System.)

SELF-SEALING MOUTHPIECES.

(Over 800 Now in Use.)

Standard Condensers. Washer-Scrubbers.

TAR WASHERS FOR WATER GAS PLANTS.

(In use in the works of the Chicago Gas Lt. Co.)

GASHOLDERS.

Bredel's Automatic Gas Governor.

Refers, by permission, to Mr. Eugene Vanderpool, Newark, N. J.; Mr E. G. Cowdery, Milwaukee, Wis.; and Mr. Theo. Forstall, Chicago, Ills. For further information, address

FRED. BREDEL,

No. 208 East Seventeenth Street, N. Y. City.

Plans and Estimates Furnished for New Works or for the Alteration of Old Works.

HENRY PRATT & CO.,
 BUILDERS OF THE
PRATT & RYAN WATER GAS GENERATORS,

Arranged to Use Either Crude Oil or Naphtha.

Condensers, Scrubbers, Purifiers, and all Apparatus for Coal or Water Gas.

IRON ROOFS, BOILERS, TANKS, ETC.

Orders and Correspondence Solicited.

Office and Works,
 869 to 875
 So. Halsted St.
CHICAGO, ILL.

COMPOUND Condensing or Non-Condensing.
 16 SIZES, 5 to 500 H. P.
 Not yet equaled by any form of Engine for
HIGH FUEL DUTY AND SIMPLICITY.

STANDARD 13-Sizes in Stock.
 5 to 250 H. P.
 3000 in use in all parts of the Civilized World.

JUNIOR 6 Sizes in Stock,
 5 to 50 H. P.
 An Automatic Engine cheaper than a Slide Valve.
 WELL BUILT. ECONOMICAL. RELIABLE.
 Over 300 Sold the First Year.

All the above built strictly to Gauge with
 INTERCHANGEABLE PARTS.
 REPAIRS CARRIED IN STOCK.

SEND FOR ILLUSTRATED CATALOGUES.

WESTINGHOUSE
ENGINES
 The Westinghouse Machine Co.
PITTSBURGH, PA. U.S.A.

SELLING DEPARTMENT IN THE UNITED STATES.

New York,	47 Cortlandt St.	} Westinghouse, Church, Kerr & Co.
Boston,	Hathaway Building,	
Pittsburgh,	Westinghouse Build'g,	
Chicago,	156, 158 Lake St.	
Philadelphia,	608 Chestnut St. M. R. Muckle, Jr. & Co.	} Fairbanks & Co.
St. Louis,	302, 304 Washington Av.	
Kansas City,	342 Union Avenue,	
Denver,	1330 Seventeenth St.	
Omaha,	1619 Capitol Avenue, F. C. Ayer.	} The D A Tompkins Co.
Pine Bluffs, Ark.	Geo. M. Dilley & Sons.	
Salt Lake City,	25 S. Main St. } Utah & Montana	
Butte, Mont.	L. Granite St. } Machinery Co.	
San Francisco,	21, 23 Fremont Street, Parke & Lacy Co.	} The D A Tompkins Co.
Portland, Or.	33, 35 N. Front St. Parke & Lacy Mch. Co.	
Charlotte, N. C.	36 College St.	} The D A Tompkins Co.
Atlanta, Ga.	45 S. Prior St.	
Dallas, Tex.	Keating Imp. & Machine Co.	} C. E. James & Co.
Chattanooga, Tenn.,		

GAS AND WATER PIPES.

GAS AND WATER PIPES.

ENGINEERS.

SAM'L R. SHIPLEY, Pres.
HENRY B. CHEW, Tre

JAS. P. MICHELLON, Sec.
WM. SEXTON, Supt.

P. D. WANNER, Chairman. A. H. MELLERT, Mangr. of Wks.
R. B. KINSEY, Secretary. F. A. KNOPP, Treasurer.

GLOUCESTER IRON WORKS,
GLOUCESTER CITY, N. J.



Cast Iron Gas & Water Pipes, Stop Valves, Fire Hydrants, Gasholders. &c.

Office, Rooms 61 and 63 Bullitt Building, 131 S. 4th St., Phila., Pa.

WARREN FOUNDRY AND MACHINE CO.,

Established 1856. Works at Phillipsburgh, N. J.

New York Office, 160 Broadway.

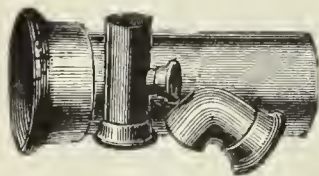

CAST IRON WATER AND GAS PIPE,

FROM TWO TO FORTY-EIGHT INCHES DIAMETER. ALSO, ALL SIZES OF

Flange Pipe for Sugar House and Mine Work. Branches, Bends, Retorts, etc., etc.

DENNIS LONG & COMPANY,

LOUISVILLE, KY.,



Manufacture Exclusively

CAST IRON GAS & WATER PIPE & SPECIAL CASTINGS
OF ALL SIZES.

King's Treatise on Coal Gas.

A standard text-book for the Engineers and Managers of Gas Works, and for all who are concerned or take an interest in the manufacture and distribution of Coal Gas, and in the utilization of the Secondary Products resulting therefrom; treating also of the Gas Engine, and of Gas Cooking and Heating Appliances.

In 3 Vols. Price per Vol., \$10. Sold either by Volume or in Sets.

A M. CALLENDER & CO., 42 Pine St., N. Y.

MELLERT FOUNDRY & MACHINE CO. Ltd.
and **READING FOUNDRY CO., Ltd.**
Reading, Pa.

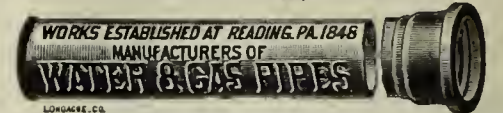

Specials—Flange Pipe, Valves and Hydrants
Lamp Posts, Retorts, etc.

General Foundry and Machine Work.

JOHN FOX, Selling Agent. 160 Broadway, N.Y.

THE OHIO PIPE COMPANY,

MANUFACTURERS OF

Cast Iron Gas & Water Pipe,

BRANCH AND SPECIAL CASTINGS.

Gas-House Bench Castings, Hydraulics, Lamp Posts, Flange Pipe
and Specials, Architectural Castings, Building Columns,
Joists, Cellar Grates, Sash Weights, etc.

GENERAL FOUNDERS AND MACHINISTS.

Columbus, Ohio.

M. J. DRUMMOND,



SPECIAL CASTINGS AND LAMP POSTS.
Office, Corbin Building, 192 Broadway, N. Y.

EMAUS PIPE FOUNDRY.

DONALDSON IRON COMPANY. EMAUS, PA.



MANUFACTURERS OF

CAST IRON PIPE AND SPECIAL CASTINGS
FOR WATER AND GAS.

JOS. R. THOMAS,

No. 42 Pine Street, N.Y. City.

CONSULTING AND CONSTRUCTING
Gas Engineer and Contractor.

PLANS, SPECIFICATIONS, AND ESTIMATES
FURNISHED.

Contracts taken for all Appliances
required at a Gas Works,
Either for New Works or Extensions to Old Plants.

WM. MOONEY

(Successor to WM. FARMER)

No. 94 Liberty St., N. Y. City.

GAS ENGINEER AND CONTRACTOR FOR THE ERECTION
OF GAS WORKS, OR APPARATUS OF ANY
CAPACITY.

Plans and Specifications Furnished.

WM. GARDNER,
Gas Engineer,

Lewis Block, Room 20, Pittsburgh, Pa.

Those who intend to make alterations in existing gas plants, or who contemplate the erection of new works, will find it to their interest to open correspondence with the above. Plans made and estimates furnished.

BARTLETT, HAYWARD & CO.

Baltimore, Md.

Triple Double, & Single-Lift
GASHOLDERS.

Iron Holder Tanks.

ROOF FRAMES.

Cirders.

BEAMS.

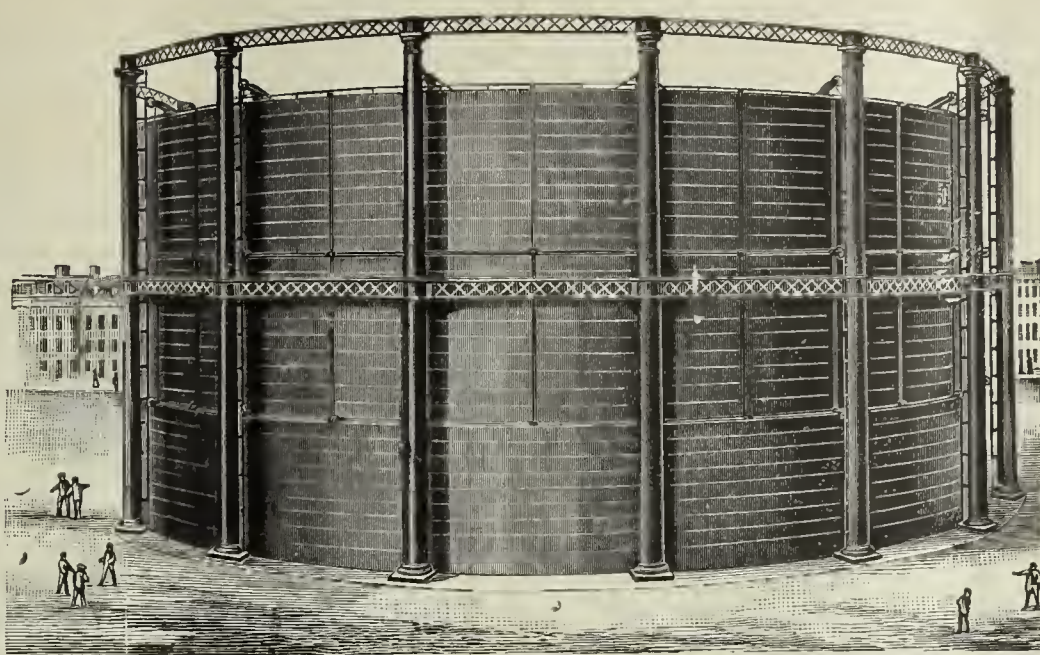

PURIFIERS.
—
CONDENSERS.

—
Scrubbers.

—
BENCH CASTINGS.

—
OIL STORAGE TANKS.

—
Boilers.

The Wilkinson Water Gas Process.

THIRTY-CANDLE, NON-CONDENSABLE, FIXED GAS. THE MOST SUCCESSFUL GAS PROCESS IN OPERATION.

Munich Regenerative Furnace, System Drs. Schilling & Bunte.

HAZELTON BOILERS.

Gas Works Designed and Constructed.

Pascal Iron Works. ESTABLISHED 1821. Delaware Iron Works.

MORRIS, TASKER & CO.,

INCORPORATED.

OFFICE, 224 SOUTH THIRD STREET, - - PHILADELPHIA, PA.

CONTRACTORS, BUILDERS, AND MANUFACTURERS OF

Gas, Water & Sugar Works

Bench Castings.

Condensers.

Scrubbers.

Purifiers.

Hyd. Carriages.

Iron Floors,

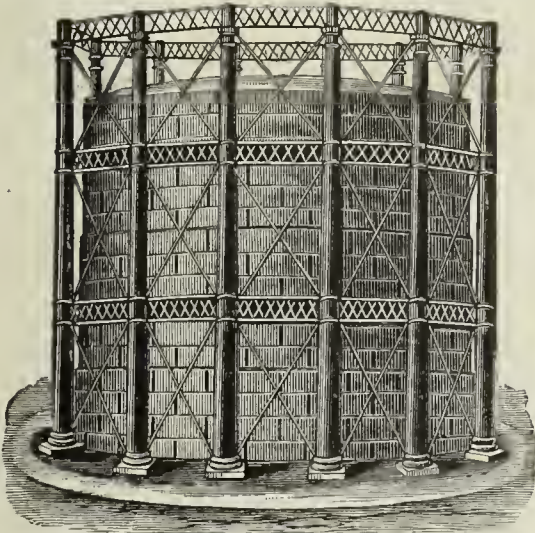

Iron Roofs.

Street Stops,

Valves, etc.

Stand-Pipes.

Water & Oil

Tanks, all Sizes.

Single, Double, and Triple-Lift Gas Holders.

SELF-SEALING RETORT LIDS. STAMPED STEEL RETORT LIDS.

Locomotive Water Columns, Filters, etc. Boiler Tubes, Wrought Iron Pipe & Fittings

Plans, Specifications and Estimates for all kinds of Machinery furnished on application.

Foundries & Works,
MILLVILLE, FLORENCE,
and CAMDEN, N. J.

R. D. WOOD & CO.,

Engineers,
Iron Founders,
and
Machinists.

400 Chestnut St., PHILADELPHIA, PA.

MANUFACTURERS OF

CAST IRON PIPE,

Gas Holders,

SINGLE, DOUBLE, AND TRIPLE LIFTS, WITH
OR WITHOUT WROUGHT IRON
OR STEEL TANKS.

PURIFIERS, CONDENSERS.

Scrubbers.

BENCH WORK.

Iron Floors and Roofs, Plate Girders.

Heavy Loam Castings.

HYDRAULIC WORK.

Lamp Posts, Valves, Etc.

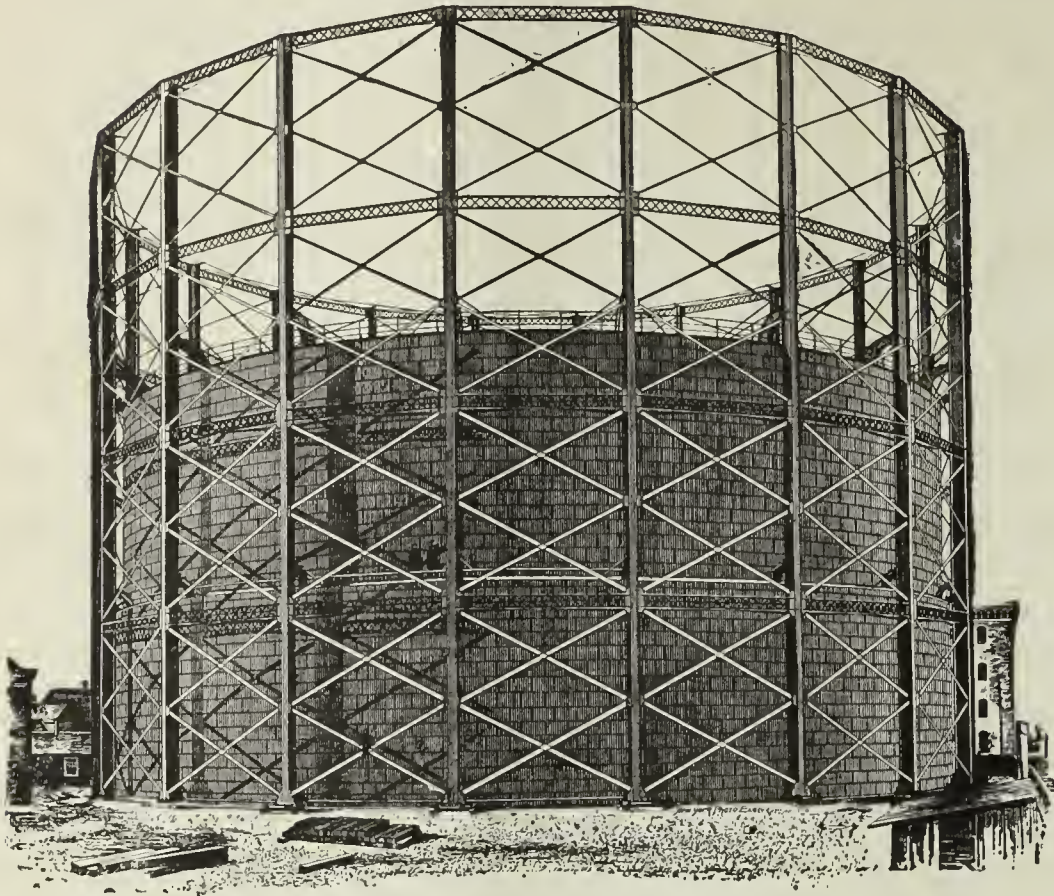

SMITH & SAYRE MFG. COMPANY,

G. G. PORTER, Prest.

245 Broadway, N. Y.

CHAS. W. ISBELL, Sec'y.

Machinery & Apparatus for Gas Works

Drawings, Plans, and Estimates Furnished for the Improvement, Extension, or Alteration of Gas Works, or for the Construction of New Works.

Mackenzie's Patent Rotary and Steam Jet Gas Exhausters, Governors, Compensators, Condensers, Washers, Scrubbers. Isbell's Patent Automatic Street Pressure Governor, Gas and Water Valves, Hydraulic Main Dip Regulator, Bench Castings, etc. Purifying Boxes and "Standard" Scrubbers, Isbell's Patent Self-Sealing Retort Doors.

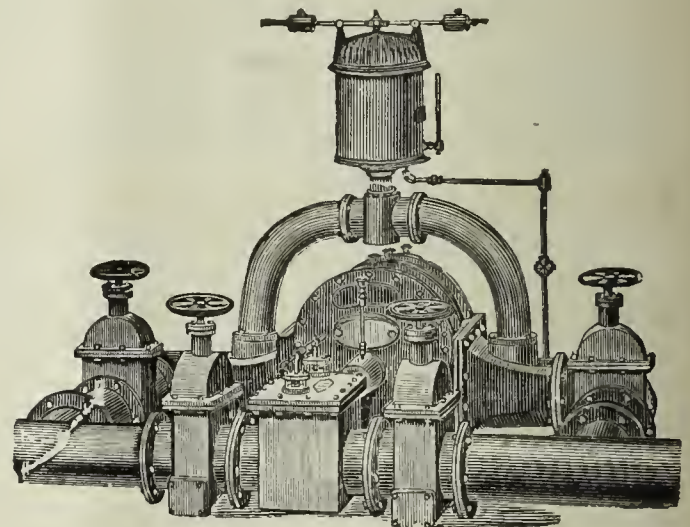

THE BRENNER SELF-SEALING RETORT DOOR.

Simple, Strong, and Durable.

CLOSES ABSOLUTELY TIGHT & IS LOCKED BY A CAM LEVER. ALL NECESSARY ADJUSTMENT FOR WEAR PROVIDED.

BUILT BY

SMITH & SAYRE MFG. CO.,

No. 245 Broadway, - - - - New York City.

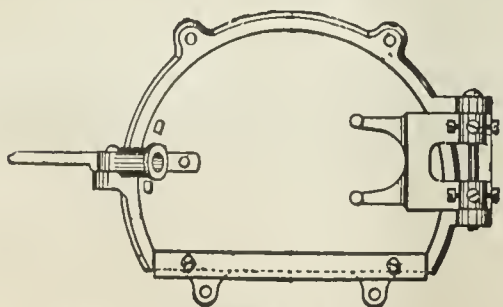

Brenner Self-Sealing Retort Door.

WILLIAM B. LUNDIE, Superintendent of the 42d Street Station of the Consolidated Gas Company, of New York, writes, under date of Jan. 4, 1889:

"We have 320 Brenner Self-Sealing Lids in use at this Station, built by the Smith & Sayre Mfg. Co. They require very little attention, and are the best of the kind that I have seen, giving entire satisfaction."

GAS WORKS APPARATUS AND CONSTRUCTION.

GAS WORKS APPARATUS AND CONSTRUCTION.

JAMES R. FLOYD & SONS,

(SUCCESSORS TO HERRING & FLOYD)

Oregon Iron Works,

W. 20th & 21st. Sts., bet. 10th & 11th Avs.,

NEW YORK CITY.

Engineers and Contractors

FOR THE

CONSTRUCTION OF GAS WORKS.

MANUFACTURERS OF

All Kinds of Castings and General Ironwork

FOR

GAS APPARATUS.

Bench Castings, Regenerative and Half Regenerative Furnace Castings.

Condensers, Scrubbers, Purifiers, Street Drips and Connections,

Valves,

Hydraulic Hoisting Purifier Carriage, Self-Sealing Retort Lids, Improved Valve Stand and Indicator, Seller's Cement.

Plans, Specifications, and Estimates furnished for Construction of New or Alteration of Old Works.

CONTINENTAL IRON WORKS.

THOS. F. ROWLAND, Prest.

WARREN E. HILL and CHAS. H. CORBETT, V-Prests.

THOS. F. ROWLAND, JR., Sec. & Tr

P. O. Station G., BROOKLYN, N. Y.

ENGINEERS AND MANUFACTURERS OF

Gas Holders

CONDENSERS, SCRUBBERS, VALVES,

PURIFIERS, SELF-SEALING RETORT LIDS

Hydraulic Mains,

And all other articles connected with the manufacture and distribution of Gas.

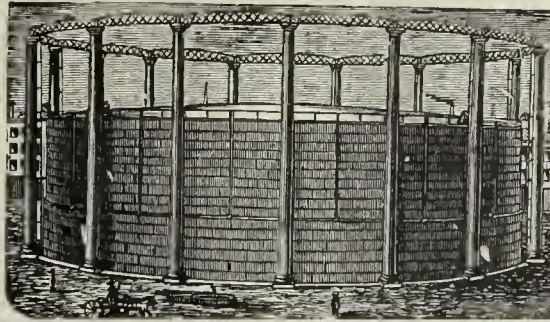

H. RANSHAW, Prest. & Mangr.

WM. STACEY, Vice-Prest.

T. H. BIRCH, Asst. Mangr.

R. J. TARVIN, Sec. & Treas.

STACEY MFG. CO.,

MANUFACTURERS OF

Single and Telescopic Gasholders,

IRON ROOFS, BRIDGES, LAMP POSTS,

Water and Oil Tanks, Coal Elevator Cars,

COKE CRUSHERS, BENCH CASTINGS,

And all kinds of Wrought and Cast Iron Work used in the erection of Coal and Oil Gas Works Rolling Mill Machinery and Heavy Castings a Specialty.

Foundry:

33, 35, 37 & 39 Mill Street.

Wrought Iron Works:

16, 18, 20, 22, 24 & 26 Ramsey Street:

Cincinnati, Ohio.

Bouton Foundry Co.,

FOUNDERS AND MACHINISTS,

CHICAGO, ILL.

Gas Works Apparatus,

PURIFIERS, CONDENSERS,

Bench Work

SPECIALS, LAMP POSTS,

SCRUBBERS,

Iron Roofs and Floors.

Plans and Estimates furnished for new works or extensions of old works.

1842. **DEILY & FOWLER,** 1889.

Laurel Iron Works.

Address, No. 39 Laurel Street, Philadelphia, Pa.

BUILDERS OF

GASHOLDERS,

Single and Telescopic.

Holders Built 1884 to 1888, Inclusive:

- | | | | | |
|----------------------------|-----------------------------|---------------------------|--------------------------|------------------------|
| Newport, R. I. | Long Island City, N. Y. | Port Chester, N. Y. | Malden, Mass. | West Chester, Pa. (2d) |
| Portland, Oregon. | Mac on, Ga. | New Rochelle, N. Y. | Paducah, Ky. | Lancaster, Pa. (3d) |
| Allegheny, Pa. (2d.) | York, Pa. | Salem, N. J. (3d) | Norwich, Conn. | Tacony, Pa. (two) |
| Atlanta, Ga. (2d.) | Chester, Pa. | Omaha, Neb. (2d) | Seattle, W. T. | Mount Vernon, N. Y. |
| N.Y. City (Central Gas Co) | Hazleton, Pa. (2d.) | Lynn, Mass. (2d) | San Diego, Cal. | Binghamton, N. Y. |
| Lynchburg, Va. (2d.) | Staten Island, N. Y. | Little Rock, Ark. | Northern Gas Lt. Co., of | Concord, N. H. |
| Saylesville, R. I. | Saugerties, N. Y. | Irvington, N. Y. | New York, N. Y. | Dover, Del. (2d) |
| Rondout, N. Y. | Clinton, Mass. (Lan. Mills) | South Boston, Mass. | Westerly, R. I. | Calais, Me. |
| Atlantic City, N. J. | Chattanooga, Tenn. | Rye, N. Y. (2) | Willimantic, Conn | New London, Conn. (2d) |
| Augusta, Ga. | Galveston, Texas. (3d.) | Woodstock, Ont. | Montclair, N. J. | West Chester, N. Y. |
| Waltham, Mass. (2) | Omaha, Neb. | Malden, Mass. | Attleboro, Mass. | Bay Shore, L. I. |
| Mahanoy City, Pa. | Fort Plain, N. Y. | Staten Island, N. Y. (2d) | Santa Cruz, Cal. | Washington, D. C. |
| New Castle, Pa. | Brunswick, Ga. | Woodstock, Ont. | Eric, Pa. (2d) | |

WM. HENRY WHITE,

No. 32 Pine Street, - - - New York City.

ENGINEER AND CONTRACTOR FOR THE

Erection and Extension of Gas, Water, and Electric Light Works.

SOLE REPRESENTATIVE OF THE

McILHENNY REGENERATOR FURNACE PATENTS

And the Martin Water Gas Process.

Edison Incandescent and American Arc Electric Light Plants Installed.

Correspondence with Gas Companies contemplating extending or improving their Plants respectfully invited. Plans and Estimates Furnished.

GAS COALS.

CANNEL COALS.

GAS ENRICHERS.

JAMES D. PERKINS. **PERKINS & CO.,** F. SEAVERNES.
228 & 229 Produce Exchange, New York.

Cable Address, "PERKINS, NEW YORK."

Post Office Box 3695, New York.

GENERAL SALES AGENTS FOR

The Youghiogeny River Coal Company's

OCEAN MINE YOUGHIOGHENY GAS COAL.

HON. W. L. SCOTT, Prest. M. H. TAYLOR, Vice-Prest.

This Colliery is located at SCOTT HAVEN, PA., in the center of the Youghiogeny Gas Coal District, and produces the ONLY RELIABLE YOUGHIOGHENY COAL for gas purposes. (See Map on p. 87 of this JOURNAL, Feb. 16, '85.)

POINTS OF SHIPMENT,

Locust Point, BALTIMORE.

Pier No. 62, PHILADELPHIA.

Also, SOLE AGENTS for the

**BRECKENRIDGE CANNEL,
OF KENTUCKY.**

Within the past two years we have delivered this Cannel to over ONE HUNDRED COMPANIES IN THIRTY-THREE DIFFERENT STATES, and it is now in use in some of the large Gas Works

On the Continent and in South America,

where it successfully competes with the Australian Shale. It is the ONLY AMERICAN GAS CANNEL of sufficiently high grade to warrant EXPORTATION TO EUROPE AND SOUTH AMERICA, and it is the only economical substitute for OIL OR NAPHTHA. ONE GROSS TON will produce

10,000 Cubic Feet of 75 Candle Gas,	} equal to {	750,000 Candle Feet of Gas, and 26 Bushels of merchantable Coke weighing 900 Pounds
or 12,500 " " 60 " "		
or 15,000 " " 50 " "		

This is the ONLY GAS CANNEL that will produce a REALLY MERCHANTABLE COKE. It can be delivered in parcels of one carload or more to any point in the United States or Canada. Cargo shipments of any size required can be made from NEW YORK, PHILADELPHIA, BALTIMORE, or NEWPORT NEWS. Samples will be sent and particulars of price, etc., forwarded upon application to above address.

JAMES & WILLIAM WOOD,
Gas and Cannel Coal Contractors,

No. 40 St. Enoch Sq., Glasgow. No. 2 Talbot Court, London.

Proprietors of the BATHVILLE COLLIERIES (which produce the celebrated BOGHEAD CANNEL), Shields, Shieldmuir, Drumpeller, and other Collieries. This Firm offer

STANDARD CANNELS,

Unequaled as Gas Enrichers.

Also, WEST FAIRMONT GAS COAL, of W. Va.

Analyses, prices, and all further information furnished on application to

Agency for U. S., Room 93, Nos. 2 & 4 Stone St., N.Y. City.

The Standard Oil Company,

REFINERS OF

NAPHTHA AND GASOLINES.

ALSO MANUFACTURERS OF

A Special Grade of Naptha for Gas Companies

FOR ENRICHING COAL GAS.

Correspondence solicited.

No. 43 Euclid Avenue, Cleveland, Ohio.

To Gas Companies.

We make to order CAP BURNERS to burn any amount under a stated pressure. Send for samples.

Also, SERVICE CLEANERS, DRIP PUMPS, and STREET MAIN PROVING APPARATUS.

C. A. GEFROER,

248 N 8th Street, Phila., Pa.

COKE CRUSHERS.

GAS COALS.

GAS COALS.

Newburgh Orrel Coal and Coke Co.

MINERS AND SHIPPERS OF

STEAM, SMITHING, AND GAS COALS,
Foundry and Crushed Coke.

Home Office, 33 S. Gay Street, Baltimore, Md.

J. HARRY LEE, President.

CHAS. W. HAYS, Agent, No. 1 Broadway, N. Y.
Shipping Wharves, Locust Point, Baltimore.

The Despard Gas Coal Co.,

MINERS AND SHIPPERS OF

DESPARD GAS COAL,

AND MANUFACTURERS OF

COKE.

MINES, Clarksburg, Harrison Co., W. Va.

WHARVES, Locust Point, Baltimore, Md.

OFFICE, 225 E. German St., " "

ROUSSEL & HICKS, } AGENTS. } BANGS & HORTON,
71 Broadway, N. Y. } 60 Congress St., Boston.

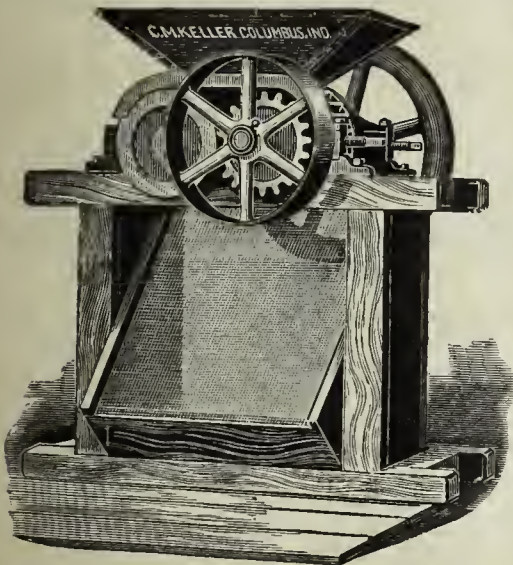

Keller's Adjustable Coke Crusher.

SIMPLE, STRONG, AND DURABLE.

C. M. Keller, Sec. & Supt. Gas Lt. & Coke Co. Columbus, Ind.

Correspondence Solicited.

King's Treatise on Coal Gas.

The most complete work on Coal Gas ever published.

Three Vols. Bound, \$30.

BOOKS.

DISTILLATION OF COAL TAR AND AMMONIACAL LIQUOR.

By GEORGE LUNGE. Price \$12.50.

A TREATISE ON THE COMPARATIVE COMMERCIAL VALUES OF GAS COALS AND CANNELS.

By DAVID A. GRAHAM. 8vo., Cloth. Price \$3.

Orders for these books may be sent to this office.

A. M. CALLENDER & CO.,

42 Pine St., N. Y. City

THE PENN GAS COAL CO.

OFFER THEIR

Coal, Carefully Screened & Prepared for Gas Purposes.

Their Property is located in the Youghiogheny Coal Basin, near Irwin and Penn Stations on the Pennsylvania Railroad, and on the Youghiogheny River.

Principal Office:

209 SOUTH THIRD STREET, PHILA., PA.

Points of Shipment:

Pennsylvania Railroad Piers; Greenwich Wharves, Delaware River; Pier No. 1 (Lower Side), South Amboy, N. J.

Chesapeake & Ohio Railway Coal Agency,

FOR THE SALE OF THE

Superior Kanawha Gas Coals, Cannelton Cannel,
Also, SPLINT AND STEAM COALS,

From the Kanawha and New River Regions, on the line of the Chesapeake & Ohio R'way.

C. B. ORCUTT, General Agent, - - No. 1 Broadway (Room 217) New York City.

FRANCIS H. JACKSON, Prest.

EDMUND H. McCULLOUGH, V.-Prest.

CHAS. F. GODSHALL, Treas.

H. C. ADAMS, Sec.

THE WESTMORELAND COAL CO.

Chartered 1854.

Mines situated on the Pennsylvania and the Baltimore and Ohio Railroads, in Westmoreland County, Penn.

POINTS OF SHIPMENT:

PHILADELPHIA, BALTIMORE, SOUTH AMBOY, N. J.,
WATKINS (SENECA LAKE), N. Y.

Since the commencement of operations by this Company its well-known Coal has been largely used by the Gas Companies of New England and the Middle States, and its character is established as having no superior in gas-giving qualities, and in freedom from sulphur and other impurities.

Principal Office, 224 South 3d St., Phila., Pa.

The American Gas Engineer and Superintendent's Handbook.

By WILLIAM MOONEY.

Consisting of Rules, Reference Tables, and Original Matter Pertaining to the Manufacture, Manipulation, and Distribution of Illuminating Gas.

350 Pages, Full Cilt Morocco. Price, by Mail, \$3.00.

A. M. CALLENDER & CO., 42 Pine St., N. Y.

GAS METERS.

GAS METERS.

GAS METERS.

JOHN J. GRIFFIN & CO.,

Gas Meter Manufacturers,

Philadelphia, New York
and Chicago,

Will Occupy this Space Hereafter.

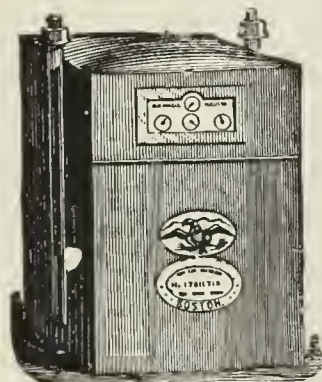

Dry Gas Meters.

With 40 years' experience and the best facilities for manufacturing, is enabled to furnish reliable work and answer orders promptly.

NATHANIEL TUFTS,

No. 153 Franklin Street, Boston, Mass.,

MANUFACTURER OF

DRY GAS METERS.

Station Meters of any Capacity.

Test and Experimental Meters, Pressure Registers, Pressure Gauges,
Pressure and Vacuum Gauges.

METER PROVERS, PHOTOMETERS, STREET LANTERNS, ETC., ETC.

Patent Cluster Lanterns for Street Illumination.

HAROLD J. BELL.

BELL & JONES,

S. LEWIS JONES.

No. 12 North Ninth Street, Philadelphia, Pa. Works at Royersford, Pa.

MANUFACTURERS OF

GAS METERS, STATION AND EXPERIMENTAL METERS,

Meter Provers, Pressure Gauges, and All Other Gas Appliances in Our Line.

WE REPAIR ALL KINDS AND MAKES OF METERS, AND THE WORK GUARANTEED.

High Pressure Meters for Natural Gas, in Iron Cases, guaranteed to stand 300 lbs. Pressure.

Gas Cooking and Heating Stoves, Hot Plates, Cake Griddles, Waffle Bakers, Boiling
Stoves, Laundry and Tailors' Iron Heaters. Hotel and Cafe Ranges a Specialty.

Correspondence Solicited.

Estimates Furnished.

SCIENTIFIC BOOKS. All books forwarded by express, upon receipt of price; if sent by mail, postage must be added to price given. We take pains in forwarding any other Works desired. Remittances by check, draft, or P.O. money order.

KING'S TREATISE ON THE MANUFACTURE OF COAL GAS. Three vols; \$10 per vol.

GAS MANUFACTURE, by WILLIAM RICHARDS. 4to., with numerous Engravings and Plates, in Cloth binding. \$12.

TECHNICAL GAS ANALYSIS. \$3.00.

GAS CONSUMER'S GUIDE. \$1.

A GUIDE TO GAS LIGHTING. 40 cents.

GAS MEASUREMENT AND GAS METER TESTING, by F. W. HARTLEY. \$1.60.

GAS CONSUMER'S HANDBOOK, by WILLIAM RICHARDS, C.E.; 18mo., Sewed. 20 cents.

A PRACTICAL TREATISE ON GAS AND VENTILATION, with Special Relation to Illuminating, Heating, and Cooking by Gas, by E. E. PERKINS. \$1.25.

PRACTICAL TREATISE ON HEAT, by THOMAS BOX. Second edition. \$5.

COAL; ITS HISTORY AND USE, by PROF. THORPE. \$3.50.

THE GAS WORKS OF LONDON, by COLBURN. 60 cents.

THE GAS FITTER'S GUIDE, Showing the Principles and Practice of Lighting with Coal Gas, by JOHN EDREDGE. 40 cents.

MUNICIPAL LIGHTING, by F. H. WHIPPLE. \$1.

GAS WORKS, AND MANUFACTURING COAL GAS, HUGHES. \$2.20.

THE MANAGEMENT OF SMALL GAS WORKS, by C. J. R. HUMPHREYS. \$1.

MANUAL FOR GAS ENGINEERING STUDENTS, by D LEE. 40 cents.

HOW TO MANAGE GAS, by F. WILKINS. Paper. 20 cents.

THE DOMESTIC USES OF COAL GAS, AS APPLIED TO LIGHTING, by W. SUGG. \$1.40.

DISTILLATION OF COAL TAR AND AMMONIACAL LIQUOR, by GEO. LUNGE. New Edition. \$12.50.

ILLUMINATING AND HEATING GAS, by W. BURNS. \$1.50.

A TREATISE ON THE COMPARATIVE COMMERCIAL VALUES OF GAS COALS AND CANNELS, by D. A. GRAHAM. 8vo., Cloth. \$3.

GAS COMPANIES DIRECTORY. \$3.

GAS VERSUS ELECTRIC LIGHT. 50 cents.

THE AMERICAN GAS ENGINEER AND SUPERINTENDENT'S HANDBOOK, by WM. MOONEY. \$3.

DIGEST OF GAS LAW. \$5.

GAS ENGINE INDICATOR DIAGRAM, by W. E. AYRTON. Paper. 20 cents.

TESTING PIPES AND PIPE JOINTS, by M. M. PATERSON. 80 cents.

DESIGNING WROUGHT AND CAST IRON WORK, by H. ADAMS. Paper. Three parts, 60 cents each.

NOTES IN MECHANICAL ENGINEERING, by H. ADAMS. \$1.

STRAINS IN IRONWORK, by H. ADAMS. With plates. \$1.75.

GAS WORKS—THEIR ARRANGEMENT, CONSTRUCTION, PLANT, AND MACHINERY. \$8.

A. M. CALLENDER & CO., 42 Pine Street, New York.

GAS METERS.

GAS METERS.

GAS METERS.

GEO. J. MCGOURKEY, Prest.

WM. H. MCFADDEN, Vice-Prest. (Phila.)

WM. N. MILSTED, Gen. Supt. and Treas. (New York).

WM. H. DOWN, Sec.

THE AMERICAN METER CO.

WET AND DRY GAS METERS.

PRESSURE REGISTERS.

METER PROVERS.

STATION METERS.

PRESSURE & VACUUM REGISTERS.

PORTABLE TEST METERS.

EXHAUSTER GOVERNORS.

PRESSURE & VACUUM GAUGES.

EXPERIMENTAL METERS.

DRY CENTER VALVES.

CRESSON GAS REGULATORS.

AMMONIA TEST METERS.

GOVERNORS FOR GAS WORKS.

MARSLAND WATER METERS.

BAR & JET PHOTOMETERS.

Manufactories:

512 West 22d St., N. Y.

Arch & 22d Sts., Phila.

GAS STOVES.

SUGG'S "STANDARD" ARGAND BURNERS,

SUGG'S ILLUMINATING POWER METER,

Wet Meters, with Lizar's "Invariable Measuring" Drum.

Agencies:

177 Elm Street, Cincinnati.

244 & 246 N. Wells Street, Chicago.

510 North Second Street, St. Louis.

222 Sutter Street, San Francisco.

HELME & McILHENNY,

(Established 1848.)

GAS METER MANUFACTURERS,

Nos. 1339 to 1349 Cherry Street, Philadelphia, Pa.,

WET AND DRY GAS METERS, STATION METERS, EXPERIMENTAL METERS, METER PROVERS,

Center Seals, Pressure Registers, Governors, Indicators, Photometers, and all other kinds of Apparatus for use in Gas Works.

FOULIS' PATENT STATION AND DISTRICT GOVERNORS.

REPAIRING DEPARTMENT.—We employ a special force of skilled workmen repairing meters of all makers.

WM WALLACE GOODWIN, Prest. and Treas.

WM. H. MERRICK, Vice-Prest.

S. L. JONES, Sec.

S. V. MERRICK, Supt.

THE GOODWIN GAS STOVE AND METER CO.,

Successors to W. W. GOODWIN & CO.

1012, 1014 and 1016 Filbert St., Phila., Pa.

142 Chambers St., New York City.

76 Dearborn, St., Chicago, Ills.

WALDO BROTHERS, Agents, 88 Water Streets, Boston, Mass.

MANUFACTURERS OF

DRY AND WET GAS METERS,

Station Meters (square, cylindrical, or in staves), Glazed Meters, King's and Sugg's Experimental Meters, Lamp Post Meters, etc., etc. Meter Provers (sizes 2, 5, and 10 feet), Pressure Gauges of all kinds, Pressure Registers, Pressure and Vacuum Registers, Pressure Indicators (sizes 4, 6, and 9 inch), King's Pressure and Vacuum Gauges, Dry and Wet Center Seals, Dry and Wet Governors, Exhauster Governors, Photometers of all descriptions. Letheby's Sulphur and Ammonia Test Apparatus complete. Also, Testing and Chemical Apparatus of all kinds, and of the most perfect description, for all purposes relating to Gas.

Manufacturers of the "SUN DIAL" GAS STOVES, for Cooking and Heating.

Goodwin's Improved Lowe's Jet Photometer.

Agents for Bray's Patent Gas Burners and Lanterns.

Special attention to Repairs of Meters and all Apparatus connected with the business. All work guaranteed first-class in every particular. Orders filled promptly.

G. B. EDWARDS, Manager, New York.

S. S. STRATTON, Manager, Chicago.

D. McDONALD & CO.,

GAS METER MANUFACTURERS.

(Established 1854.)

51 Lancaster St., Albany, N. Y. 34 & 36 West Monroe St., Chicago, Ill.

STATION METERS, EXPERIMENTAL METERS, METER PROVERS, PRESSURE & VACUUM REGISTERS, PRESSURE GAUGES, ETC

Also STAR GAS STOVES, RANGES, and HEATING STOVES.

We use only the very best materials, and employ the most skilled labor, and by our long experience (32 years) and personal supervision of every detail, we feel justified in assuring the public that our goods will give perfect satisfaction. Every Meter emanating from our establishment will bear the State Inspector's badge and will be fully warranted by us. Our Annual and Calendar will be sent to Gas Companies upon application.

250 & 252 Pearl Street,

JOHN HILLEN'S BROOKLYN GAS METER WORKS.

BROOKLYN, N. Y.

MANUFACTURER OF

IMPROVED GAS METERS

REPAIRING OF METERS (of all makers) a specialty. All defective working parts are replaced without extra charge. A guarantee is given with all work sent from this shop. Write for Price List.

NEW ONE-THIRD HORSE POWER "OTTO" GAS ENGINE.

Fitted with
TUBE IGNITER,
and of
THE MOST SIMPLE
CONSTRUCTION.

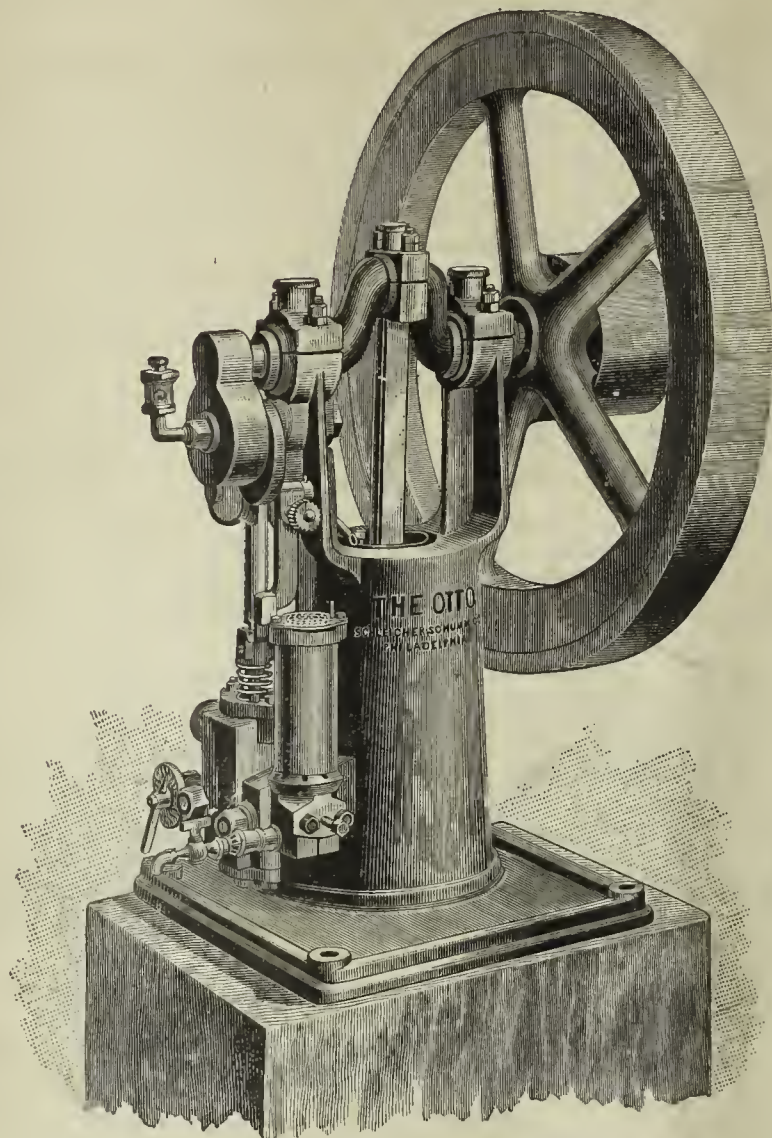

Will Regulate its
GAS CONSUMPTION
in
PROPORTION TO THE
WORK DONE.

Capable of Driving a No. 18 Enterprise or Star Coffee Mill, One Job Printing Press, Three to Four Fans, Dentists' Machinery, Amateur Tools, Household Pumps, Etc.

Many Valuable and Recent Improvements on all other Sizes,

AMONG WHICH ARE

INTERCHANGEABLE DUPLICATES OF SLIDES, PLATES, and COVERS,
Sent with each Engine Free of Charge. Also,

Power in Most Sizes has been Increased, while Floor Space has been Reduced.

SINGLE CYLINDERS AND TWIN ENGINES; HORIZONTALS AND VERTICALS, COMBINED WITH
WATER PUMPS, SEWAGE PUMPS, AIR COMPRESSORS, DYNAMOS, ETC.

Will Outdo in Economy and Every Other Respect the Rented or Electrical Power.

SIZES, 1-3d to 100 HORSE POWER.

"Otto Gas Engine Works,"

SCHLEICHER, SCHUMM & CO.,

151 Monroe St. (Kent Building), Chicago.

33d & Walnut Sts., Phila.

NEW YORK AGENCY, 18 VESEY STREET.

THE AMERICAN

GAS LIGHT JOURNAL

REDMAN & KENNY, N.Y.

PUBLISHING OFFICE No. 42 PINE STREET

DEVOTED TO THE INTERESTS OF ILLUMINATION, VENTILATION, WATER SUPPLY AND DISTRIBUTION, & GENERAL SCIENCE.

VOLUME LII.—No. 7. }
Whole No. 767.

NEW YORK, MONDAY, FEBRUARY 17, 1890.

{ \$3 PER ANNUM,
IN ADVANCE.

A. M. CALLENDER & CO., Proprietors. C. E. SANDERSON, Manager.
JOS. R. THOMAS, C.E., Editor. T. J. CUNNINGHAM, Asst. Editor.

ENTERED AT THE POST OFFICE AT NEW YORK, N. Y.
AS SECOND CLASS MATTER.

Published on each Monday of the year, at No. 42 Pine Street, N. Y.

Terms of Subscription, Including Postage.—For the United States and Canada, \$3 per annum. European countries, \$4.50 (19 shillings—22½ francs). All payments to be made in advance. Single copies, 10 cents.

Remittances should be made either by post-office order, registered letter, or bank draft on New York, payable to the order of A. M. Callender & Co.

Collections are invariably made directly from this office, for subscriptions, advertisements, etc. We have agents to solicit the same, but they are not authorized to receipt for money.

Correspondence.—Wishing to make this JOURNAL a gazette of intelligent discussion to those of our readers who may wish to gain or give information on the subjects to which its columns are devoted, correspondence is solicited for publication from all who make the study of those subjects a pleasure or a profession.

The American News Company, Nos. 39 and 41 Chambers street, New York, are agents for this JOURNAL. Newsdealers will send orders to them.

Books.—We will forward by express, at publisher's lowest rates, any book—scientific or otherwise—to any address in the United States or Canada. No books will be sent C. O. D.

CONTENTS.

An Asterisk (*) denotes an illustrated article.

OFFICIAL NOTICES—

Annual Meeting, New England Association of Gas Engineers.....	205
Ohio Gas Light Association.....	206

EDITORIALS—

Briefly Told.....	206
Attempting to Settle the Baltimore (Md.) Gas Question—Personal—Recommending a Change in the Massachusetts Carbonic Oxide Regulations—Explosion at the St. Paul (Minn.) Gas Works.	
The Market for Gas Securities.....	206
M. Sainte-Claire Deville's Theory of Coal Gas.....	207
*A Test of an Otto Gas Engine, by Edgar Kidwell and E. R. Keller	208
Water Gas for British Gas Works, by C. J. R. Humphreys.....	210
*Device for Charging Retort Furnaces with Hot Residual Coke	210
*The Walker Gas Washer.....	211
*Device for Testing the Gradients of Pipes.....	212
The Vagaries of the Electricians.....	212
Technical Education.....	213
The Possible Average Depth at which Coal is now being Worked in the British Isles.....	214

ITEMS OF INTEREST FROM VARIOUS LOCALITIES..... 214

Annual Meeting, La Fayette, Ind.—Hints from Troy, N. Y.—Opposing a Petition—They will not Try the Toraya Process—Patent Right Suit—The Suit Brought by Mr. Bostwick—How the Brazelle Process Failed at Paris, Ill.—The Clinton (Iowa) Company—Annual Meeting, Peoples Company, Jersey City—Annual Meeting, Easton, Pa.—Facts from Mr. Hidman's Report—We Think so too—Annual Meeting, New Britain, Conn.—Sale of the Corsicana (Tex.) Company—Public Lighting, Cleveland, O.—The Baltimore Knights of Labor—And Many Other Items.

On the Most Economical Engine for Small Power.....	217
Electric Light at the British Museum.....	217

[OFFICIAL NOTICE.]

New England Association of Gas Engineers.

SECRETARY'S OFFICE, BIRMINGHAM, CONN., Jan. 30, 1890.

The Twentieth Annual Meeting of the New England Association of Gas Engineers will be held at Young's Hotel, Boston, on Wednesday and Thursday, Feb. 19th and 20th. The meeting will be called to order by the President, Mr. Robert B. Taber, on the 19th inst., at 10 o'clock A.M. It can now be definitely stated that the following papers will be read sometime during the meeting:

"Vaporization and Feed of Oil to Generator or Retort," by W. R. Addicks, of Boston, Mass.

"Municipal Control of Gas and Electric Light Companies," by Dr. Robt. Amory, of Brookline, Mass.

"Management of Small Gas and Electric Light Plant," by S. J. Fowler, of Westfield, Mass.

"Some Experiments in the Photometer Room," by N. W. Gifford, of New Bedford, Mass.

"A Point or Two in Regard to Illuminants During Condensation and Purification," by George F. Goodno, of Dedham, Mass.

"Notes on Revivification of Oxide," by Waldo A. Learned, of Newton, Mass.

"Various Methods of Introducing Gas Stoves," by H. A. Norton, of Boston, Mass.

"A Few of the Advantages of Water Gas over Coal Gas for Small Works," by F. H. Parker, of Burlington, Vt.

"The Difference between Eastern and Western Methods in the Management of Gas Works," by E. G. Pratt, of Des Moines, Iowa.

"Why I Shall Make Water Gas," by A. B. Slater, of Providence, R. I.

"A Chapter of Don'ts," by W. H. Snow, of Holyoke, Mass.

"Some Notes Taken in a Small Gas Works," by Ralph Woodward, of Waltham, Mass.

"Problems Constantly before the Gas Manager," by E. H. Yorke, of Brockton, Mass.

In addition to the above there are partially promised several other papers. I think all the members who see this notice will agree that, judging by the above list, the coming meeting bids fair to be a greater success than any of the meetings which have been held in previous years. The topics are quite varied, and many of the subjects are among the most important that gas managers have to deal with at the present time.

The officers of the Association believe that no member of the Association, and no one connected with the active business management of any gas company in New England, can afford to be absent from this meeting. Persons eligible for membership and desiring to join the Association will please apply at once to the Secretary, who will forward them blank applications. Although the membership is large, there are still a good many persons connected with the gas business through New England who do not belong to the Association. It is hoped that all such persons will see fit to join at the coming meeting, and make the Association what it ought to be, truly representative of the gas interest in the New England States.

Invitations have been received to visit the Commercial Point and Bay State gas works in Boston, also the Loomis Fuel Gas plant at Waltham, which will add materially to the pleasure of the coming meeting.

CHARLES H. NETTLETON, Secretary.

[OFFICIAL NOTICE.]

Ohio Gas Light Association.

OFFICE OF SECRETARY,
COLUMBUS, O., January 20, 1890.*To Members of the Ohio Gas Light Association:*

Gentlemen—The Sixth Annual Meeting of this Association will be held at Toledo, O., on March 19 and 20, 1890.

This announcement is made thus early in order that all members may be reminded of the meeting in ample time to make their arrangements to be present. Every member is urged not only to attend this meeting, but also to interest himself in inducing others of his acquaintance who are eligible for membership, but who have not as yet joined the Association, to come to the meeting and become members.

It is not intended that as many papers as usual shall be presented at the forthcoming meeting, in order that more time than formerly may be had for the discussion of those that are read, and for such other matters and business as the members may desire to dwell upon.

Although the Secretary has for some time been engaged in the work of soliciting papers for this meeting, he has not yet secured as many as should be had, notwithstanding fewer are desired than heretofore, and he therefore earnestly calls upon all members who can possibly do so to notify him immediately of their willingness to furnish papers.

It has been decided that an interesting and valuable feature of our meeting would be a "Question Box," in which members can place questions, which will be withdrawn and read to the meeting and answered and discussed by the members. Every member is requested to send to the Secretary at once any question or questions which he would like to have thus brought before the meeting.

Future circulars will announce further details concerning the meeting.

Respectfully, IRVIN BUTTERWORTH, Sec'y.

BRIEFLY TOLD.

ATTEMPTING TO SETTLE THE BALTIMORE (MD.) GAS QUESTION—Readers of the JOURNAL have from time to time been advised of the approach toward a settlement of the matter of regulating gas rates in Baltimore, which settlement is noteworthy from the fact that its plan is based on protection to the Gas Company. The Armstrong measure was somewhat crude and its conditions were such as to antagonize the Gas Company, hence there is slight reason for believing that it will ever become law. As hinted in our last another bill (to which we believe the proprietors of the Consolidated Gas Company are not altogether averse) has been presented to the Legislature, the substance of which is shown in the following lines from a correspondent at Baltimore:

"A gas bill, which it is intended shall be reported from the Committee on Corporations as a substitute for the Armstrong bill, has been handed in. The bill provides that the Consolidated Gas Company shall have the exclusive privilege of manufacturing and furnishing gas for 25 years in the city of Baltimore, at \$1.25 per 1,000 cubic feet. In consideration of this privilege the Company is to pay into the city treasury the sum of \$10,000 per year. If the Company shall declare a dividend amounting to 3 per cent. a year, then they shall, in addition to the \$10,000, pay to the city 3 per cent. upon the 3 per cent. dividend. That is, if a 3 per cent. dividend is declared upon the present \$11,000,000 of stock, or \$330,000, the city is to get 3 per cent. upon that sum, or \$9,900, making, with the \$10,000, a total payment to the city of \$19,900 per annum. That is the full amount which the bill proposes to give the city, for there is no provision to increase the payment in the event of the Company earning, say, a 6 per cent. dividend. Mr. Colton, in committee, has amended the bill to provide that if at any time the average charges for gas in the cities of Brooklyn, New York, Boston, Jersey City, Philadelphia and Washington shall be less than the price charged in Baltimore, then the Consolidated Company shall sell gas at less than \$1.25. Another amendment provides that if at the end of ten years no dividend is declared by the Consolidated Gas Company, then the exclusive feature of the bill shall lapse. It is quite likely that this bill will be endorsed by the Legislature."

PERSONAL.—Mr. H. C. Leonard, of the Portland (Oregon) Gas Light Company, sailed from this port for Europe, per steamship Trave, on the 8th inst. He goes abroad for a pleasure trip.

MR. SAMUEL J. FOWLER has been appointed to the Superintendency of the Springfield (Mass.) Gas Light Company, vice Mr. J. L. Hallett, resigned. Mr. Fowler has for some time back been Superintendent of the Westfield (Mass.) Company.

RECOMMENDING A CHANGE IN THE MASSACHUSETTS CARBONIC OXIDE REGULATIONS.—The Board of Gas and Electric Light Commissioners (Mass.) have submitted to the Legislature the following draft of a bill proposing to alter the current restrictions in the matter of the percentage of carbonic oxide that may be retained in illuminating gas as distributed in that State—the Commissioners "strongly recommend" the passage of the measure:

"Section I.—The Board of Gas and Electric Light Commissioners may, on such terms as it deems prudent, license any gas company now or hereafter authorized to make gas for illuminating purposes to make and sell water gas for such purposes containing any percentage of carbonic oxide that said Board may determine; and may at any time, after notice to a company so licensed, alter or revoke the license.

"Section II.—The percentage of carbonic oxide allowed, and the terms and conditions imposed by said Board, shall be stated in the license, a copy of which the Company shall cause to be delivered to each of its customers; and if the Company holding the license does not exceed the limit of carbonic oxide so fixed, nor violate any of the terms and conditions contained in the license, it shall be exempt from any penalty or prohibition provided in section 14 of chapter 61 of the Public Statutes relating to carbonic oxide.

"Section III.—Chapter 428 of the Acts of the year 1888 is hereby repealed.

"Section IV.—This Act shall take effect upon its passage."

EXPLOSION AT THE ST. PAUL (MINN.) GAS WORKS.—The following letter explains itself:

THE ST. PAUL GAS LIGHT COMPANY, }
St. Paul, Minn., Feb. 10, 1890. }

To the Editor AMERICAN GAS LIGHT JOURNAL:

An explosion of gas occurred at 5.50 P.M., Saturday, the 8th inst., in our condenser room, damaging the building to the extent of some \$5,000, killing one man and injuring three others. This room is at the end of our retort house, separated by a heavy brick wall, and contains an exhauster, condenser and scrubber. The building and machinery were new, and the structure was well ventilated. The force of the explosion laid low the four walls, completely wrecking this portion of the building; but fortunately the machinery, as well as the benches in the adjoining room, suffered no damage; hence we will be able to repair the building and have the plant in operation in about 8 days. As yet we are unable to give any cause for the accident. Mr. A. D. Cressler and the writer were in this building 40 minutes previous to the explosion, and found everything in perfect working order—Mr. C. declaring our arrangement and machinery the very best. The night foreman was in this room two or three minutes prior to the accident, and declares that the machinery was working all right, with no indication of leakage. As soon as possible we cleared away the debris, in order to get the condition of seals and Huntoon governor, which we found full of water and perfectly sealed, making out the explosion to be still a greater mystery. The portion of our works containing the water gas apparatus was in no way impaired—being entirely separated from the coal gas plant—hence we were able to maintain the regular supply of the city without interruption. Daniel Desmond, the man who lost his life, was an old-time gas man, and well known to many of the gas fraternity. He came to St. Paul with Mr. Kennedy some 30 years ago, and has been in the employ of this Company during the entire period. He assisted Mr. Kennedy in the construction of this plant, and was for many years Superintendent; of late he has had charge of the street department. He was a faithful and conscientious man, and most worthy of the esteem and confidence in which he was held by this Company and all with whom he came in contact. The injured men were employed as stokers in the retort house. Should we discover the source of the accident while overhauling the machinery, etc., shall take pleasure in rendering the JOURNAL a full account of it.

Very respectfully, B. F. ELLISON, Genl. Supt.

The Market for Gas Securities.

Consolidated is at 96½, or within a quarter of a point of the price reported in our last. There is nothing of interest to note in connection with the shares, which are being withdrawn from the market every day. Brooklyn shares are steady to strong. We note the following sales at auction: 4,000 Williamsburgh 1st mortgage 6's at 111½; 223 shares Williamsburgh gas, at 121½; 50 shares Brooklyn gas, at 111½; 25 shares Nassau gas, at 120½; 100 shares Consolidated gas, at 96½; 50 shares Flushing (L. I.) gas, at 161; 500 shares Peoples gas (Brooklyn), at 80. Chicago Trusts are weaker, influenced no doubt by the attempt on the part of the authorities to reduce the gas rate to \$1 per 1,000. Laclede common is weak, at 16-18, while Bay State common is inquired for at 24-25. We note a sale of 6 shares of Petersburg (Va.) gas, at 144. The Citizens Gas Light Company (Brooklyn) has named the following Directors: S. E. Howard, John P. Rolfe, E. J. Dennison, J. W. Gordon, John Byrne, S. A. Lathrop and F. S. Smith.

M. Sainte-Claire Deville's Study of Coal Gas.*

Writing in respect to certain conclusions arrived at by him in his connection with the Paris (France) gas works, M. Deville says :

I have found that if gas taken at the exit of the meter at the commencement of the charge, *i. e.*, rich, but not tarry gas, be superheated, it requires a very intense heat applied to a slow stream of gas to produce any perceptible difference between the heated and unheated gas. The difference thus produced consists in the loss of about 12 per cent. of its benzine, and 35 cent. of its other hydrocarbons, absorbable by bromine, accompanied by the deposition of carbon in the porcelain tube, and production of naphthaline and anthracene.

If, instead of superheating the gas after purification from tar, it be heated together with the volatile products formed during the distillation, the results are the same as regards the benzine and rich hydrocarbons, so that all that can be concluded is that benzine resists a high temperature better than other hydrocarbons. This question, as to the relative amounts of benzine formed during the successive periods of the distillation, which is of theoretical interest, requires further investigation.

However this may be, we know sufficient to be able to affirm that, among all the hydrocarbons which contribute to the illuminating power, benzine is the only one which exists in considerable amount throughout the whole of the distillation.

Experiments carried out on the laboratory scale show that, speaking generally, a high temperature favors its production.

It remains to be learned whether the proportion of benzine depends on the temperature of the coal at the precise moment of decomposition, or on the temperature to which the volatile products are submitted after their formation, during their passage along the red hot walls of the retort.

Recapitulation and Conclusions.—The two chief subjects treated in this article are :

(a) The classification of gas coals according to their elementary composition.

(b) A study of the amount of benzine contained in the gas, and on the part played by this hydrocarbon in affecting the illuminating power of the gas.

I. At the experimental works of the Paris Company, during the last twelve years, 1,012 coal tests have been carried out, 36,000 kilos being employed for each test.

Of these 1,012 tests, 898 have been made with coal from 23 sources, that from each source having been tested on the average 39 times.

The average results of this large number of experiments are therefore free from variations due to accidental deviations from the normal character of the coal, and consequently clearly show the influence of the composition of the coal upon the various properties of the gas, which are of interest to the gas manufacturer.

The basis selected for this classification is the amount of oxygen contained in the coal, which is considered to represent the combined water, and thus to be the best indication of the geological age of the coal and of its degree of carbonization.

By dividing the coals tested into five classes of types, containing increasing amounts of oxygen, from 5.5—12 per cent., and by calculating the average results from each type, the following conclusions have been arrived at :

As the coal becomes richer in oxygen, the gas produced by its distillation becomes gradually richer in heavy constituents—carbonic acid, carbonic oxide, marsh gas, and illuminating hydrocarbons, and poorer in pure hydrogen.

Its density and illuminating power both increase. It is also to be observed that the proportion of volatile matter, determined by calcination in a crucible, also increases, even when the amount of combined water is deducted.

The volume of coke remaining in the retorts becomes larger as the percentage of oxygen diminishes. The products of condensation (tar and ammoniacal liquors) increase with the amount of oxygen.

Considering the five types of coal, it is found that type III. comprises the best gas coals, those namely which give a rich gas and yet leave a fair quantity of coke of good quality. Types I. or II. give inferior gas, but much coke.

The remaining classes—IV. and V.—give a rich gas, but their coke is small in quantity and of poor quality.

II. The benzine contained in gas may be estimated by simply weighing the products condensed at -22° , and adding to the weight thus found per cubic meter (moist at 15°) a constant equal to 23.5 grms.

I have shown :

(1.) That air artificially charged with a known weight of pure benzine deposits the whole of this at -70° , and that the amount which condenses between -22° and -70° , is exactly equal to 23.5 grms. per cubic meter (dry at 0° 1,760 min.); this number agrees with that calculated from Regnault's numbers for the vapor pressure of benzine.

(2) That gas treated in the same manner deposits, whatever be its composition, 247 grms. of liquid between the same temperatures, from every cubic meter measured dry at 0° 1,760 min., which corresponds to 23.5 grms. per cubic meter, moist at 15° .

(3) That the liquid thus deposited consists of almost exactly 23.5 grms. of pure benzine, mixed with a little toluene, xylene, etc.

Applying this method of determination under very varied circumstances, I have arrived at the following conclusions :

(a) The average gas of the city of Paris contains 39 — 40 grms. of benzine per cubic meter, composed of :

Pure benzine.....	77
Other hydrocarbons of the aromatic series....	23
	100

From 7 — 8 per cent. of the weight, and from 1 — 1.1 per cent. of the volume of the gas is therefore made up of benzine vapor.

Independently of benzine, the gas contains 4 — 4.5 per cent. by volume of hydrocarbons incombustible at 70° .

The illuminating power of the gas is found to be :

Due to benzine.....	65
Due to other hydrocarbons.....	35
	100

(b) The various qualities of gas may be classed in two symmetrical groups with—

I. Rich, or comparatively rich, gases.

- A. Produced from oxygenated coals.
- B. Obtained by distillation, at a low temperature.
- C. Evolved during the first stages of distillation.

II. Poor, or comparatively poor, gases.

- A. Produced from coal poor in oxygen.
- B. Obtained by distillation at high temperatures.
- C. Evolved during the last stages of distillation.

(1) The weight of benzine contained in a cubic meter of gas is almost the same in all six varieties.

(2) The benzine obtained from gases of the second group is a little richer in pure benzine, and, consequently, a little poorer in toluene and cumene, etc., than from those of the first group. The difference is small but clearly marked.

(3) Rich gases of the first group at the moment of leaving the retort are at a lower temperature than those of the second group, or, to speak more accurately, the temperature of the coal at the exact moment of decomposition is higher for gases of the second group than for similar ones of the first.

We see, therefore, that rise of temperature appears to have the effect of progressively destroying the hydrocarbons of the olefine and acetylenic series, and also those of the aromatic series, with the exception of benzine; of producing, or, at least, of not destroying benzine; of producing pure hydrogen; and finally, of forming naphthaline, anthracene and graphite.

These results may, therefore, be considered as an industrial confirmation of Berthelot's theories on the subject.

(c) As regards illuminating power, benzine plays a secondary part in very rich gases, an important part in gases of average richness, and is almost the sole source of the light given by very poor gases. If the whole quantity of benzine present in a gas be removed by refrigeration to 70° , and the loss of illuminating power thus occasioned divided by the weight condensed (which is almost constant for all gases), it is found that the quotient, which expresses the candle power of one gramme of benzine burnt in 100 liters of gas, is much higher for poor than for rich gases.

The limits actually observed are 0.040 candles and 0.250 candles.

This proves that if gas, itself devoid of illuminating power, be progressively enriched with a hydrocarbon, that the illuminating power of the mixture increases much less rapidly than its richness in illuminating material.

It is necessary to remark that these facts have only been proved by applying to all gases, rich or poor, the photometric method founded on the use of the Bengel burner.

It would be interesting to study the variation of illuminating power when each gas was burned at a burner suited to its composition, as the Bengel burner is adapted to the average Paris gas.

* See JOURNAL, Nov. 4, 1889, p. 633.

A Test of an Otto Gas Engine.

By EDGAR KIDWELL and EDWIN R. KELLER.

[An abstract of a test made by the authors for a graduating thesis in the Department of Mechanical Engineering, University of Pennsylvania. The article originally appeared in the *Journal of the Franklin Institute*.]

Methods.—The engine experimented on was a 7-horse power (nominal) Otto type engine. The volume of the cylinder and clearance space was determined by filling with water and found to be 0.439 cubic feet for the total volume, and 0.1796 cubic feet for the clearance space, leaving 0.2594 cubic feet for the volume swept through by the piston each stroke.

The gas used during the test was passed through a large meter, and thence through rubber bags to the cylinder, a portion passing through a second meter, being taken from the same supply for the jet.

The pressure of the gas used was taken by a manometer attached to the supply pipe, and the absolute pressure of the gas was found by adding to this reading that of the standard signal service barometer. The temperature of the gas was taken as that of the room, the meter, bags and pipes being practically entirely within the room. Samples of the gas were taken for analysis. The amount of cooling water used was weighed by allowing it to discharge in a vessel for periods of ten minutes during the test, the water running at practically the same quantity per minute throughout the entire test. The temperature of the water before and after leaving the cylinder jacket was taken by thermometers placed as shown in Fig. 1, which also shows the position of a Brown's

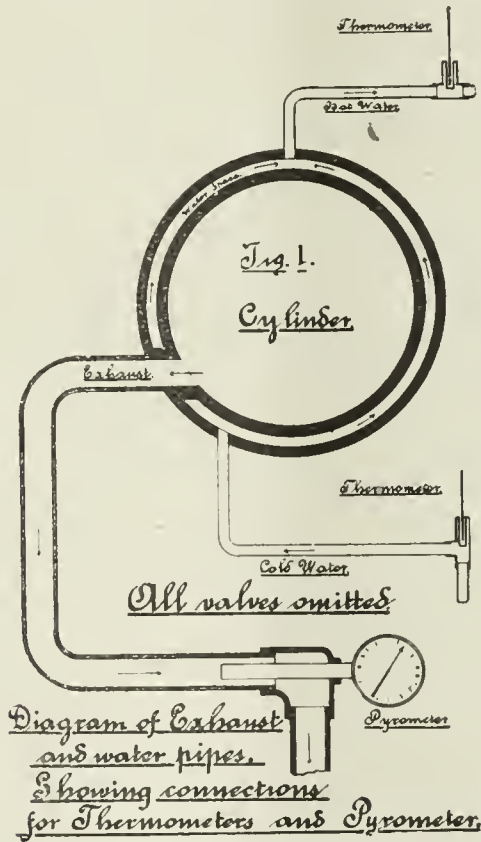

pyrometer placed in the exhaust pipe of the engine. The length of pipe between the cylinder and pyrometer was carefully covered with asbestos board, preventing radiation to a great extent.

The power developed in the cylinder during each explosion was determined from a mean indicator card constructed as described below, the power given off by the engine being absorbed by a friction brake on the fly-wheel.

The speed was taken every five minutes by a revolution counter and stop-watch.

It was found necessary to limit the duration of the tests to one hour at a time, because of the heating of the fly-wheel. The engine was started and allowed to run an hour; the brake was then put on, and after the engine had settled down to steady condition the test began. It was continued for an hour, the brake was removed, and the engine kept running until the wheel cooled down, when the brake was replaced and another set of observations made. The total duration of the tests, that is, the actual time during which the observations were made, was three hours, ten minutes.

Apparatus.—The thermometers used were made by Henry J. Green, of New York, and read to degrees Fahrenheit. The pyrometer used was made by Edward Brown, of Philadelphia, and was graduated at intervals of 10° to 1,200° F. The revolution counter used was of the endless screw and wheel type, reading to single revolution. The stop watch read to one-fifth second. The meters used were a large one, made by the Goodwin Meter Company, for gas engine tests, and an ordinary 7-light meter made by the same Company. The scales for weighing the water read to 1/100-pound.

The apparatus used for analyzing the gas was an Elliott apparatus, similar to that used at the International Electrical Exhibition, in 1884.

A Crosby indicator, with a 100-pound spring, was used throughout the test.

The bulbs of the thermometers used for measuring the temperature of the jacket water were inserted in thin metal cups screwed into the pipe connections, as shown in Fig. 1, the lower one being kept full of water, and the upper one of oil.

The following are some of the results of the test :

Date, Jan. 19, 1889.	
Time of test.....	3 hrs. 10 m.
Temperature gas.....	62°.2
Temperature of exhaust.....	774°.28
Temperature of entering water.....	50°.43
Temperature of exit water.....	89°.19
Manometer, inches water.....	3.06
Barometer (reduced to pounds).....	14.85
Total gas used, cubic feet.....	344.4
Gas for ignition.....	9.625
Average revolutions per minute.....	161.6
Explosions missed per minute.....	6.83

Computation.—As the test was rather for determining the distribution of the head developed by burning the gas, or for getting data for determining its efficiency as a heat engine rather than as a machine, and as the observing force was limited, the brake horse power was not taken.

The indicator cards were worked up in the following way. Fig. 2 is

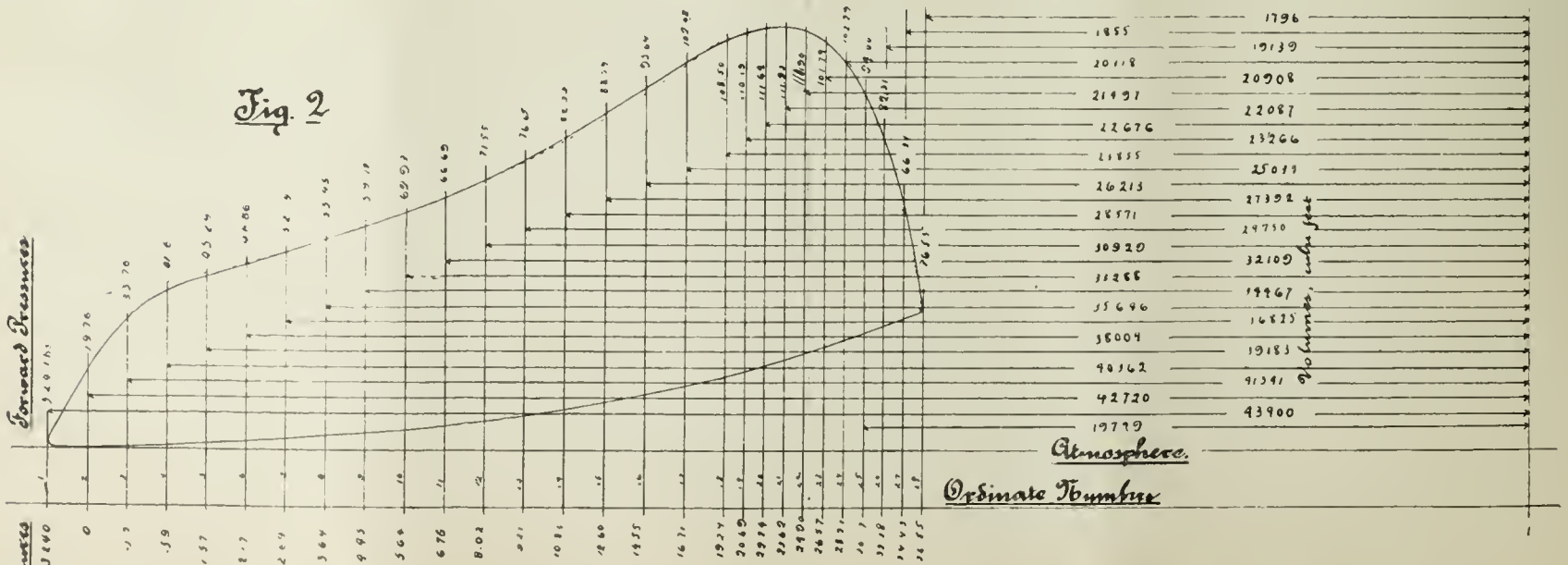

Indicator Diagram of Otto Gas Engine. Mean of 42 Cards. Scale, 25 lbs = 1" 3/16 in. ft = 1' Speed, 161.6 Revolutions per minute. Area card = 22 sq. in. Mean effective pressure = 59 lbs.

a mean card obtained as follows: On each of the 42 cards taken 28 lines were drawn at right angles to the atmospheric line as shown, and the pressure of the bottom and top of each card was read and tabulated. From the mean of these tabulated values the card shown in the figure was drawn. From this card the horse power was calculated as follows:

- Mean pressure for card = 59 pounds.
- Mean pressure per foot = 59 × 144 pounds.
- Value of stroke in feet = .2594.
- Work per explosion = 59 × 154 × .2594 ft. pounds.

$$\text{Explosion per minute} = \frac{161.6}{2} - 6.83 = 73.97.$$

$$\text{Horse power} = \frac{73.97 \times 59 \times 144 \times .2594}{33,000} = 4.939.$$

It will be noticed that the exhaust and admission parts of the diagram are omitted, as they practically coincided with the atmospheric line.

In addition to finding the work done, the mean card was used to determine the general equation of the expansion, compression, and explosion part of the diagram.

In determining these curves the part between ordinates (8) and (28) was taken for the compression curve in the calculation; the explosion curve was taken to embrace all the upper curve between (23) and (28); and the expansion curve was taken to cover all the upper curves between (5) and (18).

The expansion and compression curves were assumed to vary according to a law $p v^n = c$, in which p is the pressure in pounds per square inch and v = the volume in cubic feet of the mixture, while c and n are constants. By taking the values of p and v , as given on the mean indicator card by the method of Least Squares, the most probable values of n and c were determined.

The equation to the curve of expansion was found to be

$$p v^{1.4385} = 15.901,$$

and for the compression curve was found to be—

$$p v^{1.5313} = 3.7557.$$

The explosion curve was found to be practically a parabola, whose equation is—

$$y = -1.788 x + 32.833 \pm \sqrt{89.423 x - 1588.61}, \text{ in which}$$

$$y = \frac{p}{10}, x = 100 v.$$

The broken lines on Fig. 2 show the curves corresponding to the equation, and the following table gives the errors by calculation:

Expansion Curve.

v	p from Equation.	p from Card.	v	p from Equation.	p from Card.
.23855	124.97	123.20	.32109	81.52	81.39
.25034	116.60	117.18	.33288	77.41	77.63
.26213	109.11	110.34	.34467	73.62	73.89
.27392	102.47	103.49	.35646	70.14	70.15
.28571	96.44	97.03	.36825	66.97	66.89
.29750	90.98	91.25	.38004	63.98	63.56
.30929	86.02	86.25	.39183	61.23	59.99

Compression Curve.

v	p from Equation.	p from Card.	v	p from Equation.	p from Card.
.17960	52.06	52.25	.25034	31.32	31.41
.18550	49.55	49.13	.26213	29.19	29.25
.19139	47.24	47.08	.27392	27.29	27.30
.19729	45.09	44.87	.28571	25.58	25.53
.20318	43.10	42.91	.29750	24.04	23.91
.20908	41.26	41.27	.30929	22.65	22.72
.21497	39.54	39.60	.32109	21.39	21.46
.22089	37.93	38.32	.33288	20.24	20.34
.22676	36.43	36.94	.34467	19.19	19.15
.23266	35.03	35.39	.35646	18.22	18.34
.23855	33.70	33.94			

Explosion Curve.

v	p from Equation.	p from Card.	v	p from Equation.	p from Card.
.1796	48.90	51.25	.19729	108.70	108.70
.1855	80.59	81.01	.20318	116.55	116.99
.19139	97.10	97.01	.20908	121.91	122.49

Heat.

From the mean indicator card it was found that the mean pressure was 59 pounds per square inch, and the work performed per explosion was 59 × 144 × .2594 (volume passed through by the piston) = 2203.8 foot pounds. This is equivalent to—

$$\frac{2203.8}{772} = 2.854$$

heat units transformed into work at each explosion.

From the amount and temperature of the jacket water it was found that 461.92 heat units were carried away per minute by the cooling water. Or, as there were 73.97 explosions per minute—

$$\frac{461.92}{73.97} = 6.24$$

heat units removed per explosion by the cooling water.

The following gives the results of the tests of the gas used as determined by the Elliott apparatus:

	By Volume. Per Cent.	By Weight. Per Cent.
CO ₂50	1.923
C ₂ H ₄	4.32	10.520
O.....	1.00	2.797
CO.....	6.33	15.419
CH ₄	27.18	38.042
H.....	51.57	9.021
N.....	9.06	22.273

The following are the calculated results from these values:

	Weight per Explosion.	Heat Developed per Explosion	Oxygen Required.	Products of Combustion— H ₂ O.	CO ₂ .
CO ₂00001210
C ₂ H ₄00013903	1.6785	.0004566700001210
O.....	.0000242000002420	.00017852	.00043682
CO.....	.00011313	.5322	.0000646400017776
CH ₄00027730	6.4927	.00110920	.00062396	.00076260
H.....	.00006580	3.7364	.00052640	.00059216
N.....	.00016190
	.00079346	12.4398	.00213271	.00139464	.00138928
Nitrogen.....007101
Air required.....00923373
Gas.....00079346
Total water gas and air entering cylinder per explosion.....01003319
H ₂ O.....00139464
N added.....00710110
N.....00016190
01005594

The heat carried off in the products of combustion is—

	Heat Units.	Per Cent.
In H ₂ O (steam).....	1.9291	
CO ₂2149	
N.....	.2438	
Heat carried off in exhaust.....	3.4049 = $\frac{3.40}{12.44}$	= 27.93
Heat converted into work.....	2.85	= 22.91
Heat taken by jacket water.....	6.24	= 50.16
Total heat accounted for ..	12.49	100.4
Total heat received.....	12.44	

These calculations are made on the supposition that the amount of air supplied to the cylinder is just enough to cause complete combustion, and are given for what they are worth. That they are, at least to a certain extent, justifiable can be seen by the following:

.00079346 pounds of gas occupying $\frac{334.78 \text{ (cubic feet, total)}}{14054 \text{ (no. explosion)}}$ cubic feet, at 62.2° F. and a pressure of 14.96 pounds per square inch, requires .00923373 pounds of air to completely burn it.

It is fair to suppose that just before the mixture of gas and air is compressed it has the temperature of the cylinder, which must be about that of the jacket water, or 89.19° F. The gas occupies a volume of

$$\frac{334.78}{14054} \times \frac{548.59}{521.6} \times \frac{14.96}{14.85} = .02523 \text{ cubic feet.}$$

.00923373 pounds of air at 14.85 pounds per square inch and a temperature of 89.19 occupies .22985 cubic feet. The total volume occupied by the gas and air is therefore .25508 cubic feet. The clearance volume was filled with the products of combustion at this same pressure and temperature before the mixture of gas and air was drawn in. The incoming gas and air should therefore fill a volume equal to the stroke displacement, or .2594 cubic feet, and we have therefore a volume of air = .2594 — .25508 = .00432 cubic feet of air drawn in, but not used, a quantity that we can omit in our calculations.

Water Gas for British Gas Works.

By C. J. R. HUMPHREYS.

[Communicated by the author to the *London Journal*.]

I have been very much interested in the article which appeared in the *Journal* for Nov. 19, last year (p. 962), entitled, "Is Water Gas Possible for British Gas Works?" wherein you—very justly, I think—make the point that at this time it is not wise to declare that water gas is inadmissible to British gas works. The article interests me particularly, as I have been using water gas in connection with coal gas at my own works; and on this general question I should like to speak at length. I will, however, reserve what I have to say on the point for another time; and will consider in the present communication that portion of your article in which you deal with inclined retorts in connection with the manufacture of water gas. This is a very interesting phase of the question, because, admittedly, where water gas is to be used as an auxiliary in connection with the manufacture of coal gas, the coke resulting from the manufacture of gas by the regular process is the fuel which should be used in the production of water gas—firstly, because the fuel is right at hand; and, secondly, because it disposes at once of a portion of a residual product which at times is nearly a drug on our hands. Obviously, then, the scheme is to convey the coke from the retorts to the cupolas with the least possible amount of labor; and if the heat which the coke possesses when it leaves the retorts can be retained till it is deposited in the cupolas, there is a very decided gain. I believe that in some gas works in this country—notably the Kansas City (Mo.) works—the coal is conveyed from the retorts (which are horizontal, fired by generator furnaces) to the cupolas in buggies; but clearly more labor is involved in the scheme than would be required if inclined retorts were used, and so disposed that the coke from them would drop readily into the cupolas—or generators, as perhaps they are more commonly called. In fact, it was when the manufacture of fuel gas came under consideration, and the imperative necessity of reducing the labor per 1,000 cubic feet of gas manufactured to the lowest point was apparent, that the advantages of inclined retorts presented themselves. From these investigations there grew the fuel-gas process of Messrs. A. C. Humphreys and Walton Clark, which combines the inclined retorts for the manufacture of coal gas and the generators for the production of water gas.

In the article to which I have already referred, the statement is made that the combination of the inclined retort and the water-gas generator is made use of in more than one fuel-gas process; but, as far as my knowledge goes, it is only used in the Humphreys-Clark process. As I have had an opportunity of making a cursory examination of the experimental plant which has been put up at Jersey City, N. J., to show the working of the process, a short description of the scene may not be without interest; reserving for a future occasion a more extended description of the plant, with an account of the results obtained. Concisely stated, the works consist of two benches of inclined retorts, and a generator in front of each setting adjacent to the lower end of the retorts; and the dampers and valves are so arranged that the "blow" gases from the generators can be passed round the retorts of either or both of the settings, or they can go direct to the stack, or any portion of the waste gases can be lead to the settings, and only the balance allowed to escape through the chimney. In working the plant, the coal (ordinary bituminous gas coal) is conveyed to the upper end of the retorts on an overhead track in buggies with openings in the bottom through which the coal is dumped on to a shoot, which guides the coal into the mouth of the retort. The arrangement of the shoot is somewhat peculiar, and of such a nature that the angle it makes with the mouth of the retort can be quickly changed. By experiment, it has been determined what is the proper angle to employ for different kinds of coal; consequently it is found easy in practice to discharge the coal from the buggies into the retort so that the coal will be spread evenly over the length of the latter, without any danger of running through the retort into the channels connecting the generators and the retorts. The coal is baked in the retorts in the usual time—viz., four hours—during part of which the water gas from the generators is allowed to flow through the retorts; the hydrogen absorbing most of the lighter hydrocarbons which in ordinary distillation pass off as tar. From the retorts the combined gas passes through a hydraulic main, and is drawn by an exhaustor through condensers, scrubbers, etc. At the end of the period of distillation the red hot coke is pushed from the retorts into the generator. During this process it is not found necessary to remove the lid, as, by a peculiar plunger device, the coke is readily pushed from the retort. By this means the retort is, in a few seconds emptied of the coke resulting from the carbonization of 250 lbs. of coal. The retorts are

heated by the waste heat of the gases which pass off from the generators during the time of "blowing up;" and the interiors of the retorts are heated by the passage through them of the hot water gas made during the run.

It will thus be seen that the process embodies many economies—the utilization of a portion of the waste or "blow" gases from the generators; the absorption of a portion of the heat of the water gas (which those who have made water gas know to be an item of importance); and the conservation of the heat which the coke possesses as it passes from the retort. Add to this the almost infinitesimal amount of labor involved—the term is not too strong when we remember that all the labor required besides working the valves is the filling of the coal buggies and conveying them to the elevator—and the licking up of the tarry vapor by the water gas in the retorts (for it is found that very little tar is collected in the drips), and we have the promise of a very cheap gas. The resulting gas is, of course, a mixture of coal and water gas of but very low illuminating power, but exceeding in heating effect many of the so-called fuel gases. Add to this scheme an oil carbureter and superheater, and by the use of 2 gallons of Lima crude oil per 1,000 feet, a good illuminating gas could be produced. We thus see the vast possibilities of such a plan—not in the fuel gas field alone, but also, and perhaps to a far greater extent, in that of illuminating gas, unless the future development of the plan brings to light some unforeseen and untoward obstacle.

I hope to be able, in the near future, to take up this matter again, and describe the plant more in detail, and give more information in regard to the nature of the gas produced.

Device for Charging Gas Retort Furnaces with Hot Residual Coke.

Mr. G. R. Hislop, of Paisley, Scotland, has been granted English letters patent (No. 3,391, Feb. 26, 1889) for an invention the object of which is to provide means for directly charging gas producers and gas or shale oil retort furnaces with hot residual coke from the retorts heated by such furnaces, in lieu of transferring the hot coke into buggies and charging the furnaces therefrom.

To that end there is formed a mouthpiece upon a crown plate which is bolted on the top of the projecting brick breastwork of the retort oven and over the ordinary cleaning and charging doors; and therefrom there is formed a shoot extending downwards and rearwards through the upper front wall of the furnace at such an inclination as to discharge the fuel at or near the middle of the furnace. This mouthpiece is furnished with a self-sealing door operated by levers; and it has hinged or jointed to it a hopper which may be raised and held by a

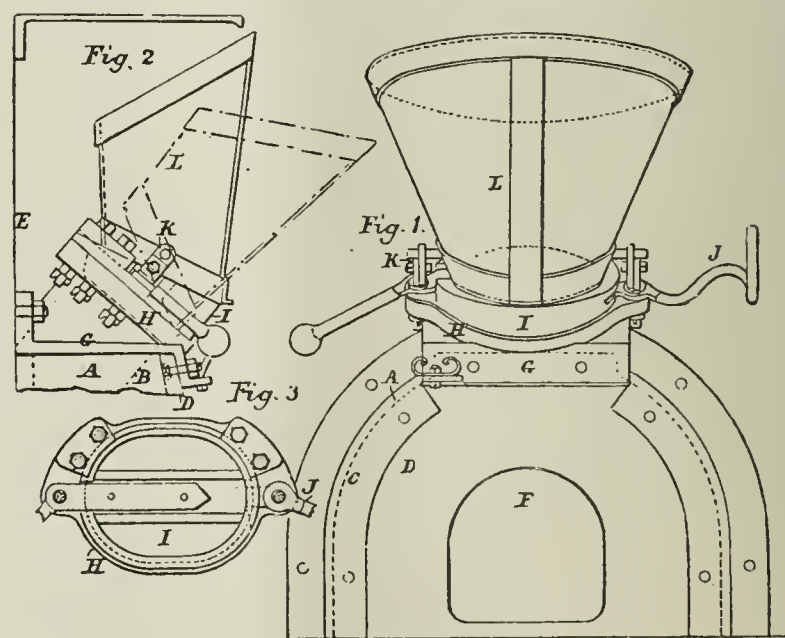

catch close up against the front of the retorts, or lowered and retained (by the same or a separate catch) in such a position that it forms an inclined plane over which and through the mouthpiece the hot residual coke drawn from the retorts is discharged directly into the producer or furnace.

Fig. 1 is a front elevation, and Fig. 2 a side elevation, showing the hopper and part of the front of the retort oven. Fig. 3 is a detailed view of the door covering the shoot leading from the hopper.

The crown of the producer is terminated preferably in an arch of brickwork A; and through the top a port or shoot B is formed for the

passage of the coke into the producer. The upper or arched portion is bound together by metal jacket plates *C*, securely bolted to the front plate *D* of the producer and the front of the oven *E* respectively. The front plate is furnished with an upper door *F* to facilitate the cleaning of, and a lower one (not shown) for withdrawing the ashes from, the producer. On the top of the jacket plates and over the opening *B* for the passage of the coke, a cast iron crown plate *G*, with doorway *H*, is fixed at a suitable inclination from the face of the oven. The doorway *H* is furnished with ears and stop snugs, and is planed on its face and fitted with a corresponding door or disc *I* hinged on a pin passing through the one ear and held by a jamming lever *J* on the other. The disc *I* at the back passes under pocket plates fixed on snugs to define the travel and fix the position of the disc. On top of the pins passing through the ears and hinging the disc and jamming lever, adjustable journaled *K* are formed to receive and carry the axis pin of the charging hopper *L*. The latter is preferably ovular in form and expanded at the mouth to the width of the retort or retorts above. The hopper is preferably placed immediately under the central retorts of the oven; and by casting the hinged oscillating disc *I* sufficiently thick on its lower edge to reduce the angle of inclination, it, when shut, holds the outer edge of the hopper within the line of the retort mouthpieces, and simultaneously with allowing the disc *I* to fall out of position, by reversing the jamming lever *J*, the hopper *L* also falls to the necessary angle to receive the contents of the retorts above it, which are shot into the producer at such an angle as to deposit them in the center of the furnace.

The Walker Gas Washer.

United States letters patent (in supplement of English letters patent, No. 14,925, granted October 17, 1888) No. 420,751 were granted, on the 4th inst., to Mr. William T. Walker, Highgate, England, for certain improvements in apparatus to be used in the purification of coal gas. In his specification, Mr. Walker says:

This invention has reference to apparatus for purifying coal gas—such, for example, as the apparatus described in the specification of letters patent No. 245,527, of August 9, 1881—in which apparatus surfaces are alternately submerged in liquid and raised by a vertical reciprocal dipping movement, so that they when raised present a freshly wetted surface to the gas to be purified, which passes in contact therewith.

Apparatus of this description is very liable to become clogged and inoperative by the accumulation of dense matters; and it is the object of this invention to overcome that objection, to reduce the first cost of the apparatus, and to simplify it and generally render it better adapted for use, as hereinafter described.

iron, to contain the wetted surfaces, the said frames being open at the bottom and at the sides. They are operated by a reciprocating vertical dipping movement, and the said boxes are at each downward movement entirely submerged, so that the liquid scours and washes the said surfaces, and any thick or dense matter is carried freely off and discharged clear of them. The surfaces contained in the said boxes may be made of any suitable material; but Mr. Walker prefers for the purpose either

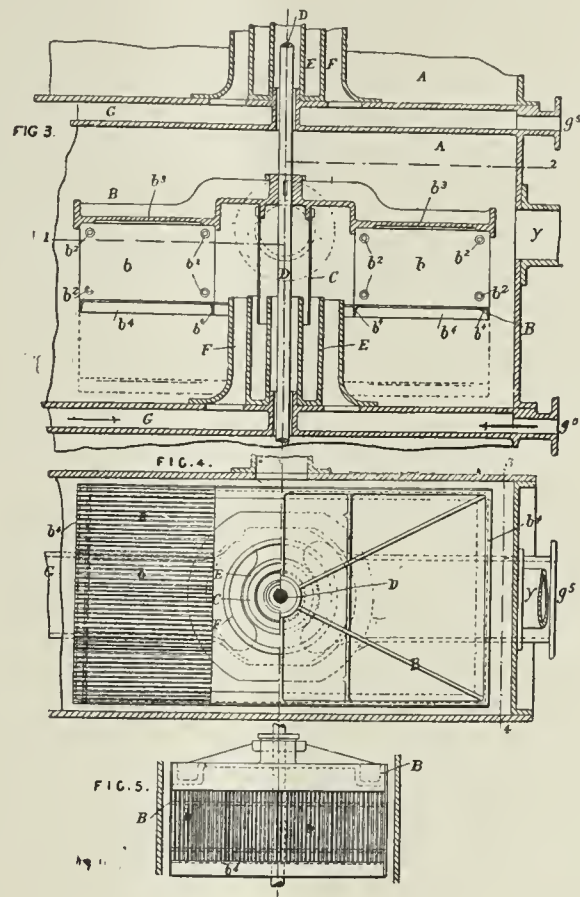

plain iron plates or thin boards of wood, *b*, which may be connected together in groups by bolts, *b*², passing through all the plates or boards. Distance pieces are placed between the plates or boards to keep the proper spaces between them. They are supported at their ends upon the angle bars *b*⁴. The said plates or boards *b* are set vertically and a free-way is left between them to allow the dense or thick matter to be washed freely from them. The said spaces are entirely free and open at the bottom and at the sides, as shown clearly at Fig. 5, and there is also a space between the tops of the said plates or boards and the top of the box *B*, as at *b*³ in Fig. 3, to allow of the free passage of the washing liquid. Thus arranged the apparatus is adapted for purifying the gas as it passes from the condensers to the purifiers, and it may be used either in place of or in combination with the ordinary apparatus for purifying gas by oxide of iron or lime. He effects this by isolating the interiors of the superposed tanks *A* from each other by a gas tight seal, consisting of an inverted bell *C*, which is secured to the casting *B*, and that in turn is secured to the operating shaft *D*. The said bell *C* dips into a vessel *E*, secured to the tank and containing liquid, so that the joint is maintained by the liquid as the shaft *D* reciprocates vertically. The gas inlet passage to each tank is, at *F*, external to the said seal and between the opposite sets of wetted surfaces *b b*, and receives the gas to be purified, preferably, from a flat connecting passage *G* beneath each tank *A*, and with a mouth at each side of the machine—one for the attachment of the branch from the inlet main and the other at *g*⁵ for facilitating cleaning. The machine, thus having each of its superposed tanks *A* isolated one from the other, and so constructed as to bring its inlets and outlets to its exterior, can be arranged with a system of connecting pipes and valves, enabling the gas which is to be purified to be brought into communication with any chemical agent, in either or any of the tanks, in any order desired. Thus the gas, after having its tar extracted in the lowermost portion of the machine, may be conducted from No. 1 tank through all the tanks above to No. 6 tank, or either of the tanks may be by-passed; or the gas may be conducted so as to work right round in a circuit. For example, it may be conducted first to tanks Nos. 5 and 6, and thence to tanks Nos. 1, 2, 3 and 4. These connections and valves, as shown in Figs. 1 and 2, are as follows:

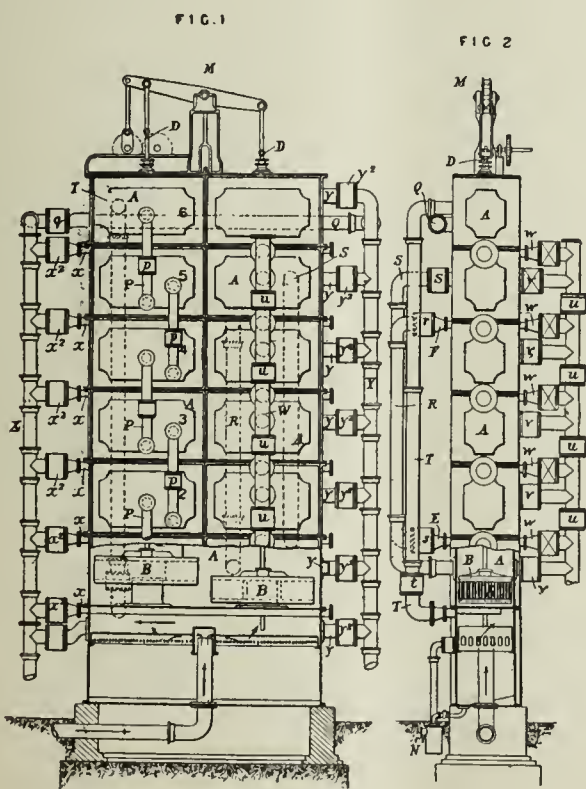

Figures 1 and 2 are elevations at right angles to each other (the lower parts being in section) of an apparatus arranged according to the new method. Fig. 3 is an enlarged section of a part of the same. Fig. 4 is a horizontal section on the line 1 2, Fig. 3. Fig. 5 is a vertical section on the line 3 4, Fig. 4.

According to the plan frames *B* are constructed preferably of cast

X is the general inlet main, having a branch *x* and a valve *x*² to each tank leading into the passage *G*. *Y* is the general outlet main, having a branch *y* and valve *y*² to each tank. *W* is a main for working or by-passing any of the tanks, the said main having inlet branches and valves *w*, outlet branches and valves *v*, and by-pass valves *u* to each

tank. *T* is the return main for conveying the gas from No. 6 tank at the top to No. 1 at the bottom, and *t* is its valve. *S* is a pipe for conveying the gas from No. 5 tank to No. 2, and *s* are its valves. *R* is a pipe for conveying the gas from No. 1 tank to No. 5 tank, and *r* is its valve. *Q* is the general by-pass main for by-passing the whole of the tanks, and *q* is its valve. *P* are the liquor overflow pipes for conveying the purifying liquids from one chamber to another, and *p* are their valves. The gas inlet is shown by the arrows in the lower part of Fig. 1; *N* is the tar well; *M* is the apparatus for reciprocating the boxes *B*.

Device for Testing the Gradients of Pipes.

Mr. J. Leslie Anderson, of Newcastle-on-Tyne, England, recommends the use of the simple instrument herewith illustrated as a ready means for testing the gradients of pipes. The inventor has used it with unvarying satisfaction for a term of years.

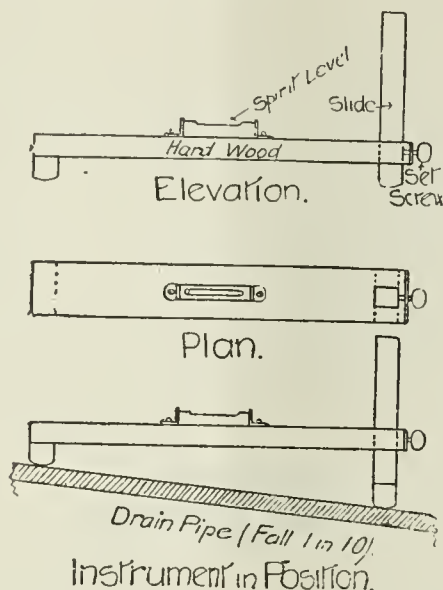

By simply laying it on its side over a detail of the required gradient the instrument can be at once adjusted, there being no need to mark a scale of gradients on the slide, although that could be done if desired.

The Vagaries of the Electricians.

The *Gas World*, in commenting on certain proposed electric installations in England, remarks:

The vagaries of the electric light are so pronounced that the exhibition of the same undesirable qualities by its professors does not strike the observer as a thing surprising. We are accustomed to hear so many contradictory opinions expressed by the electricians that one more or less does not affect the general result—they are all taken by sensible people *cum grano salis*. We would not for a moment suggest that the many eminent men who have associated themselves with electric science wilfully endeavor to mislead the public; rather would we say that it is a case of the blind leading the blind. In this country we have a body of consulting electrical engineers whose names are honored and respected throughout the length and breadth of the land—they are recognized as men who have attained the highest scientific distinction—but so far as the commercial side of their particular science is concerned they are but as babes. The operations of the practical workers in the realms of electricity have up to now been upon so limited a scale, comparatively speaking, that consulting engineers have not yet had placed at their disposal the data necessary to a uniformity of opinion. They can ascertain the price of a dynamo, the price of a lamp, and the price of a yard of copper wire; but there is very little to guide them to a proper estimate of what these three are capable of when coupled up, or how long they will last. The multiplication of "systems" is another complicating element. The consulting engineer may have some reliable data concerning a continuous-current low-pressure installation; but then his note-book fails him when he wants to compare this with any other kind of installation. The truth is the consulting engineers are groping in the dark, and they have not the courage to confess it. Data is what they require, and, judging from the slow progress the Deptford scheme is making, practical workers are not in a hurry to supply their wants.

We have before us a recent example of what we have indicated above. For an electric light works to supply 10,000 sixteen-candle power lamps in St. Pancras, Prof. H. Robinson, M.Inst.C.E., estimates the cost at £49,731; for an installation of the same size in Brighton, Mr. Shool-

bred's estimate is £30,000—practically a difference of £20,000. The systems are different and the localities are different; but each engineer thinks his system the best, and the difference of locality cannot amount to much, seeing that neither estimate includes the cost of a site. Of Mr. Shoolbred's report to the Brighton Council we have little to say, beyond congratulating that gentleman on the bold manner in which he solves the problem which has been puzzling the heads of scientists ever since electricity became known. He says: "It may here be mentioned that the words 'current' and the 'flow' thereof, still popularly used in speaking of electrical matters, are not intended to mean any actual translation of matter. Those words imply more precisely that the molecules forming the conducting wires are thrown, by the exciting magnetism of the dynamo, into a temporary and unstable condition of disturbance, and that this artificial condition is communicated from one molecule to its neighbor, and so throughout the length of the conductor." We cannot say that Mr. Shoolbred's definition is incorrect; we can only remind him that it is not yet generally recognized.

Professor Robinson's report to the St. Pancras Vestry, an abstract of which appeared in our last issue (pp. 100, 101), calls for more detailed notice, inasmuch as, if hurriedly read, it may lead to erroneous conclusions. Professor Robinson deals with both big and little figures. The big ones are comparatively plain, but the little ones must be studied to be understood. Briefly stated, the scheme which he has recommended to the St. Pancras Vestry, and which the Vestry has adopted, is this: A central station to produce current for 10,000 16-candle incandescent lamps; neighborhood of central station to be supplied direct at low pressure; outlying districts to be supplied from five transformer stations worked from the central station by continuous high-pressure current; transformer stations to be also storage stations (with about two hours supply in store!). The cost of erecting the central station and the transformer stations (with the necessary generating plant and storage batteries, and six miles of mains capable of supplying 25,000 lamps) he estimates at £49,731. This does not include the cost of a site for the central station, the Vestry, we believe, having vacant land whereon it can be erected. These works he estimates equal to produce 600,000 watts—530,000 to the incandescent lamps, 20,000 to 40 arc lamps to be used for street lighting, and 100,000 watts of leakage—introducing a point upon which data is much required.

The annual cost of running the installation next engages Professor Robinson's attention. The current supplied to the arc lamps in the streets he charges at 3½d. per unit, and the total cost per lamp per annum (including lamplighter, which is evidently a misnomer) he places at £38 11s. 4d.—£1,542 13s. 4d. for the forty lamps. The two hundred gas lamps which the forty arcs will displace cost only £560 per annum, but then Professor Robinson triumphantly exclaims that the increased cost will result in an increase of 1,300 per cent. in light. If those who put forward this statement could only realize what it means they would abstain from their folly. But at present we are concerned with Professor Robinson's figures, not his fancies. As we have seen, he puts the cost of supplying an arc lamp at £38 11s. 4d. per annum, but to this we have to add the cost of the lamps themselves. "The prime cost of the forty arc lights, if erected in the cheapest possible manner, would be," says the Professor, "£1,000." No provision for renewals, for interest, or for redemption of capital appears to be made. Five per cent. would be a very low estimate to cover the omissions. Add five per cent. to £38 11s. 4d., and we get £40 9s. 10d. as the annual cost of an arc lamp—£1,620 for 40 arc lamps, against £560 for 200 gas lamps! If this is the best St. Pancras can do so much the worse for St. Pancras. In most towns in the United States, were gas is so dear, the electric light companies would be ashamed to charge such a price as this.

It is where Professor Robinson deals with the cost of producing the electric current that his report becomes most misleading. For 10,000 lamps he estimates an annual consumption of 800,000 units, and the cost of producing this he puts at 2.80d. per unit. To this, however, he adds 0.75d. for sinking fund (does this include interest?)—making the cost 3.55d. per unit. But if this be correct, it is astonishing that we have not heard of any dividend being declared by those companies who are charging 8d. per unit. To talk about 3½d. per unit when 7d. or 8d. is the usual price may be an alluring bait to the St. Pancras householder at the first glance, but let us see how matters would stand with him were he to get the electric light at Professor Robinson's cost price. For 1,000 hours electric light: 60 units at 3½d. = 17s. 6d. + 3s. 9d. for a lamp = 21s. 3d. For 1,000 hours gas lighting: 5,000 cubic feet of gas at 2s. 6d. per 1,000 = 12s. 6d. + 1d. for burner, 12s. 7d. That is to say, taking Professor Robinson's figures at their best and the figures for gas at their worst, the price of electric lighting would exceed that of gas lighting by close upon 70 per cent. In Brighton, where the Corporation proposes to charge 6d.

per unit, the difference in cost between electric lighting and gas lighting will be about the same. It is to be hoped that the householders of St. Pancras and of Brighton will be made aware of these simple facts before it is too late.

Technical Education.

Engineering, in discussing this subject editorially, remarks that the subject of technical education, like the poor, we have always with us, and for this reason it is apt to be continually shelved till a convenient season, in the press of subjects of more immediate but not greater interest. We are reminded of our duties in this matter by the receipt of several recent publications, which suggest points decidedly deserving of consideration. One of the most important of these particulars is a compilation issued by the National Association for the Promotion of Technical and Secondary Education, entitled "Technical Education in England and Wales." This work is intended to give a brief account of the main objects and working of the chief organizations and institutions which at present exist in England and Wales for promoting and diffusing technical and scientific instruction. A triple classification is attempted, the compilers dividing the matter according to organizations, to grades, and to localities. This has raised an initial difficulty which might well have been avoided; but in spite of it the work is one which may be cordially recommended to all interested in the subject; a term which will naturally include every intelligent employer of labor, and indeed every patriotic individual throughout the kingdom. In saying this we do not wish to support that wholesale demand for technical education, the "vague cry," as Lord Armstrong calls it, which some sciolists appear to think is the panacea for all industrial ills. In fact, much harm has been done by what is termed technical education, wrongly so called if we are to give the term education its true dignity of the acquirement of useful knowledge. In our own profession more especially this danger exists, that we may become too professorial. It is a rock the French educationalists have split upon, and even the practical Germans with their vast system of State-supported education, have failed to avoid it altogether.

Professor Coleman Sellers, of the Stevens Institute of Technology, has recently given in a letter to the *United States Railroad Gazette*, a few instances worth quoting. He mentions some mathematical professors who were fond of discussing equations at once capable of application to the motions of the planets, and of the connecting rod of a steam engine; but they had only developed their knowledge in the former direction, and the transformations needed to reduce it to shape were by no means easy. Even when practical problems are approached by the mathematicians, it is considered, Professor Sellers remarks, rather undignified to make them too practical, and broad generalizations are preferred to direct every-day examples.

Professor Sellers illustrates this by an incident within his own knowledge. Some years ago it was determined by the authorities to make the *Journal of the Franklin Institute* of a less severely scientific but more useful character. A new editor was appointed, and among articles awaiting publication were found some of a highly mathematical character from the pen of a certain learned professor. These were returned to the writer with an intimation that they were hardly of sufficient interest to mechanics at large to be appropriate to the new character of the journal, and asking him to contribute something of a more popular character. The professor took the matter in good part; he said that he had himself been surprised that the journal was willing to publish articles of so purely a theoretical character as he had been writing, but as long as they were willing, he, as a mathematician, was well pleased to work in that line. In place of the mathematical dissertation, he inclosed a valuable practical discussion on the action of jam nuts.

This professor was evidently a man of good nature and good sense, which only emphasizes the moral of the tale; but we will quote Professor Sellers' own words: "The incident well illustrates the tendency on the part of the educated professional instructor to direct his energies along the line of the general and unpractical rather than that of the concrete and useful. And it naturally followed that young men taught under this system, if they came into the workshop, would be distinguished more by ignorance of the concrete methods there called for than by their knowledge, however profound, of the generalities which were not required and which they did not know how to reduce to some useful shape."

This is the danger into which an ill-considered scheme of technical education is likely to lead. There is something about the educational profession that has a narrowing tendency, and it is only the most healthy and practical characters can withstand this. Schoolmasters and profes-

sors are always apt to forget that education is a means to an end; and it may be said in passing that the present system on which State education is conducted is calculated to intensify this evil. Fortunately for us at present the chief engineering professors at our technical colleges have not been professors all their lives, but have acquired their scientific knowledge in the course of practical work. Unhappily there are signs that this wholesome state of affairs is not likely to continue, and young men—sometimes very young men—fresh from college, are being appointed to professorial chairs. It is not possible for a teacher to know what scientific attainments will be of the greatest value to the future practical or producing engineer unless the teacher has been himself engaged in practical work. In writing on this subject over 20 years ago, when technical education was seldom heard of, we took occasion to point out the danger of over-refinement of theory. If it were necessary then, how much more so is it now when the professor is so widely abroad.

It may be said that it is the professor's duty to teach only the scientific principles upon which the practical work of the engineer should be founded, leaving the application of these principles to the time when the student shall be launched on his career in life. As a general proposition this is not to be gainsaid. The most perfect academical training cannot take the place of practical work. For educational purposes we had better be without our colleges than our workshops, and that is the reason British engineers still rank before all others, and that in spite of the admirable State-supported systems of technical education of Germany, France and Switzerland. But whilst we acknowledge this limitation to the professor's duties, we must not forget that men, especially young men of the students' age, are not machines, and want some living interest to give them zest for their work. There are few so mentally constituted as to delight in mathematics for their own sake (even the great Bidder invoked the aid of peas), and even these few are little likely to become successful engineers. The purely professional training can hardly fail to relapse into that barbarous system of doing lessons for lesson's sake under which nine out of ten middle-aged persons were brought up.

It is to such reasons that the success of the few private technical schools which we possess in connection with works, such as Armstrong's, the London and North-Western, at Crewe, and Mather and Platt's may be attributed. The latter has been especially successful and is worked on an eminently practical basis. In his evidence before the Royal Commission on Technical Education, Mr. Mather described the system upon which it is carried on. The drawings made are of work actually in progress in the shops. One day the teacher, who is employed in the works himself, gives the necessary calculations, and the next the pupil sees the work carried out practically and commercially in the shops. Mr. Mather told the Commissioners that his firm had derived incalculable advantage from the school. "We desire," he said, "to send out yearly one or two thoroughly competent men who shall not be simply mechanics in the ordinary sense of the word, but shall be able to turn their attention to anything coming under their notice, whether they have done the same thing before or not. We had the greatest difficulty in finding such men until we began to take them from the school; and since the school has been established we have been able to send boys of 20 and 21 to long distances from England, and place in their hands work with which they have not had much to do before."

We have dwelt at length on what appears to us to be the great danger to which technical education is subject. Great Britain has everything to expect from technical education; without it our still unrivalled factories and workshops will not keep us in front of the world's industry. Prof. Coleman Sellers tells another tale, not this time of a professor. The owner of a large machine shop once applied to him for a spur-wheel. He had marked the diameter on a wooden rod. On being asked whether the mark indicated outside diameter or pitch line, he replied: "Pitch line! What the h— is pitch line? I want a wheel as big as this stick with eighty teeth in it." Now, it will be evident that such men as this, however well equipped for primitive times and rural districts, are not calculated to uphold national engineering industry; but we would rather depend on such a one than on the product of the professors referred to, who could not accommodate the mathematics of the solar system to the movement of crank and connecting rod.

MR. REED, of the Wyoming Legislature, has moved for the adoption of a bill providing for the granting of franchises to gas companies by local authorities; said grants, however, not to become operative until they shall have been indorsed by the voters of the cities affected by said grants.

The Possible Average Depth at Which Coal is Now Being Worked in the British Isles.

In a paper read by Mr. Jas. Dickinson, Inspector of Mines, at a meeting of the Manchester Geological Society, the author gives the following opinions respecting this subject

In connection with the question of the progress of the exhaustion of our coal fields there is a point of much interest which could only be successfully dealt with by the co-operation of mining engineers well acquainted with the different districts. I refer to the depth at which coal is being extracted, and the rate at which that average is increasing during successive intervals of (say) 20 or 25 years. With the information now in my possession I cannot pretend to offer more than a very general answer to the question of the average depth, and it is tolerably certain that even between our largest and most important coal fields there may be considerable difference in the average depth of coal produced in each. The question is not to be solved by taking the depths of the deepest and shallowest pits, and taking the mean proportional between them, for we must recollect that the rate of output from shallow pits will generally be very much slower than that from deep pits, as owing to the great primary cost of the latter they can only be made to yield a profit after a large quantity of coal has been raised and disposed of; while, on the other hand, a comparatively small output will suffice to keep a shallow colliery alive. On the above accounts an estimate could be more nearly arrived at by supposing the average depth to be somewhat greater than that between the shallowest and the deepest pits. If we suppose that at the time of the introduction of the steam engine into coal mining in 1820-25, the average depth did not exceed one hundred yards, owing to the necessity of employing horse power for winding and pumping, and if we were to assume the average depth at the present day to be 350-400 yards (probably a near approximation) we should be able to determine the rate of increase of average depth during the last 65 or 70 years. Supposing the rate to have been uniform (which it unquestionably was not) the increase of the average depth would have been at the rate of $4\frac{1}{2}$ yards per annum, or 90 yards in 20 years. But the rate of increase ought to be represented not by a straight line but by a curve corresponding in some degree to that which represents the progressive rate of coal-production from the beginning of the century to the present time. The fact that more than one seam of coal is worked in a coal district somewhat complicates the problem here presented, and for the sake of simplicity it might be stated as "the depth from which the maximum quantity of coal is raised." Now this could be determined if we had before us the depths of all the coal pits or their workings and the output from each particular seam; but this could not be obtained without investigation into details which, proprietors might not wish to have revealed, and which we should have no right to demand. There could be no objection, however, as it seems to me to the disclosure of the depths of all the pits in a coal district and the name of the seam worked; in fact, these details are generally fully known, and if we take these details as a sufficiently close approximation, and make a correction for the cause indicated above, we may come to a tolerably close approximation as regards the average depth. Such details regarding the coal fields of Yorkshire, Derbyshire, and Notts, have been furnished to me by my friend, Mr. J. T. Boot, mining engineer, of Mansfield, and from a comparison of the depths I have obtained the following results, which may not be without interest:

Depth of Collieries in the Counties of York, Derby and Notts.

Yards.	Collieries.	Yards.	Collieries.
Between 0 and 50.....	* 8	Between 300 and 350.....	8
Between 50 and 100.....	*14	Between 350 and 400.....	2
Between 100 and 150.....	*31	Between 400 and 450.....	2
Between 150 and 200.....	21	Between 450 and 500.....	5
Between 200 and 250.....	14	Between 500 and 550.....	4
Between 250 and 300.....	10	Between 650 and 700.....	1

* Some of these are not at work.

Mr. Boot states that in any estimate as to the average depth of mining the shallow pits ought not to be taken into account, some of them not being even at work. If, then, we disregard pits over 100 yards and assume that the output of the deeper pits (say those under 250 yards) is about double that of the shallower (say under 250 yards), we still find that the depth of maximum output will be at a depth of about 250 yards, there being 66 collieries above that line and 32 below, I think 250 yards is in all probability a close approximation for this great coal field, considering that owing to a general low dip of the bed and the occurrence of local flexures (forming synclinal and anticlinal curves) the seams remain at comparatively shallow depths over large areas. As regards the Lancashire and Cheshire coal field, including that of Burnley, I feel satisfied from my own knowledge that the case is different, and that a

depth of 250 yards would by no means represent the average for coal production. Perhaps some member of the society would endeavor to work the question out for this district on the principle I have adopted above for the Yorkshire and Derbyshire district, or upon some more reliable data. On the whole, I am of opinion that a depth of 350 to 400 yards would represent more nearly that here under discussion. As regards other coal fields, those of Newcastle, Central Scotland, Staffordshire and South Wales are the most important; and as far as my information extends I am led to believe that a similar depth (that of 250 yards) represents that from which the maximum quantity of coal is now being raised. In conclusion, I would venture to urge on H. M.'s Inspector of Mines, and especially on Mr. Dickinson, the importance of taking up this problem with reference to each of the coal fields under their charge, as by such determinations we shall arrive at a truer knowledge of the exhaustion of our coal fields than by any other method.

ITEMS OF INTEREST FROM VARIOUS LOCALITIES.

MR. ADAM WALLACE, Secretary of the La Fayette (Ind.) Gas Light Company, writing under date of the 5th inst., says: "The following may be of interest to you and the gas fraternity. On Monday, Feb. 3d, the stockholders of this Company held their annual meeting and elected the following to serve as Directors: Cyrus Bell, A. Wilson, Wm. Wallace, R. R. Hitt, J. O. Morgan, R. W. Sample and C. H. Peirce; Mr. R. W. Sample succeeding the late Mr. Moses Fowler, who had been President of the Company. Mr. C. H. Peirce took the place held by his father, from January, 1857, until the death of the latter in January last. The Board then elected Wm. Wallace President, and A. Wilson, Treasurer, reappointing myself to the Secretaryship. Mr. Wm. Wallace has held the position of Superintendent for the last 23 years, which position he still retains in connection with the Presidency. The Company contemplates adding a water gas apparatus to be run as an auxiliary to the coal gas plant. While we do no city lighting our sales of gas show a large increase for the year 1889, with excellent prospects for 1890."

At a meeting of the Directors of the Troy (N. Y.) Gas Light Company, held about a fortnight ago, the feasibility of disposing of the Company's property, corner of Hill and Liberty streets and on North Fourth street, was discussed. It was decided to locate the new works of the Company on the site of the Hannibal Green spring factory at the foot of Smith avenue. Secretary Davenport, in confirming this report of the action of the Directors, said: "It is the intention of the Company to dispose of all the property which cannot be profitably employed. We intend to consolidate our gas making plant, in so far as it is possible, under one roof. The holder on Jefferson street will be retained, and it is likely that the holders at Liberty and Hill streets will also not be disposed of. All the other buildings and land at the latter place will be parted with, and so will the uptown works at North Fourth street. Many advantages will accrue to the Company under the new scheme. We will have our own dock for the reception of coal, which heretofore we have been compelled to cart at a great expense. We can also take our water direct from the river, which will be a decided advantage over the driven well system." From this it will be seen that Supt. Henry C. Shields has a busy season before him.

EARLY this month President Odiorne, of the Gloucester (Mass.) Gas Light Company, appeared before the local committee on Mercantile Affairs to oppose the petition of Geo. Moore and others, who propose to incorporate the Union Electric Light and Power Company. He urged that the field for the supply of artificial light was so restricted that two companies could not possibly survive with profit to the shareholders. He would not, however, oppose the furnishing of electricity by the petitioners for power purposes. The Committee reserved its decision, but in all probability the matter will eventually come before the Board of Gas and Electric Light Commissioners.

THE ordinance to grant the Toraya Gas Company the use of the Manayunk station of the Philadelphia City gas works for a protracted trial of its system of wood gas manufacture has been voted on adversely by the Philadelphia Select Council. The vote was 26 against to 1 in favor.

IT is reported that Messrs. Lord & McCabe have brought suit against the New Orleans Gas Light Company, alleging that defendant has infringed certain patent rights vested in plaintiff. In its answer defendant pleads that it had constructed, used and operated an apparatus for

manufacturing illuminating gas from petroleum long prior to the issuance of the letters patent to plaintiffs herein to wit (since April, 1873), and which apparatus it uses and was using at the time of the institution of this suit. That the essential idea and feature of the said apparatus as used by the defendant consists of a system of double retorts, or a retort within a retort, used for the purpose of vaporizing petroleum, and this combination of retorts was no novelty at the time of the issuance of the letters patent referred to in plaintiff's petition, but were well known to science and in practical use in the manufacture of gas throughout this country and Europe—notably by the Springfield (Mass.) Gas Company, the Boston (Mass.) Gas Company, the Metropolitan (N. Y.) Gas Company, the Laclede (St. Louis) Gas Company, the Cleveland (Ohio) Gas Company, and by many others. Again, defendant specially denies that it has in any way infringed upon the patent rights asserted by plaintiffs, or that it has in any manner used the ideas or combination claimed as essential novelties in said patent. The case is before Judge Edward C. Billings, in the United States Circuit Court for the district.

IN completion of our former mention that one H. Bostwick had prayed for the appointment of a receiver for the Hastings (Neb.) Gas Light Company, we might add that the impelling cause for this action is to be found in the fact that Bostwick claims the sum of \$3,000 "for services rendered in soliciting patronage for the Gas Light Company, and for other services done and performed for the Company since January 1st, 1886." The peculiar interest attaching to Mr. Bostwick's "modest claim"—it really amounts to asking \$1,500 per annum for two years' services—will be readily appreciated from the following analysis that comes to us from a Hastings correspondent: "When this case is properly indexed it ought to read 'Harrison Bostwick vs. Harrison Bostwick,' instead of 'Harrison Bostwick vs. The Hastings Gas Light Company,' for he virtually sues himself. When Mr. Bostwick (some 4 years ago) was seen going from house to house soliciting patronage for the Gas Company, the people presumed that he was so engaged because of his desire (so loudly and frequently proclaimed) to forward the interests of an enterprise that promised to be of great local value; and Mr. Bostwick was given great praise for his public spirit. Now, however, he claims that the Gas Company, estimating at its true value his ability to wield important political and personal influence, employed him to obtain patronage and secure consumers for it, and alleges that because he is now performing like service for a rival Company, his old employers refuse to pay for what he did for them. The old Company replies that it never employed him, hence it owes him nothing. The trial of this case and its results are of vital interest to many people in this city. Should the issue go to the Supreme Court, there to be decided that the man who has given encouragement to home enterprises is entitled to recover the sum of \$1,500 per annum for his services, there will be no end to the litigation that would surely follow. If that rule would hold good, I make bold to say that our local paper, for instance, could collect a sum sufficient to pay for the construction of a building that would put in the shade the famed Equitable Building of New York city. Again, if Mr. Bostwick recovers the amount for which he sues, it will not be safe for any party to make an investment here until the assurance is given that no 'influential' and 'patriotic' citizen has signed an agreement that he will either solicit patronage for or give encouragement to the proposed enterprise."

THE Pennsylvania Gas Company (natural gas) has issued a notice to the effect that no new patrons can be served from the Jamestown (N. Y.) lines, as the capacity of the same is unequal to any further drain.

THE Columbia (Pa.) Gas Company has chosen the following officers: President, James A. Myers; Secretary and Treasurer, J. C. Clarke; Superintendent, Wm. B. Faesig.

THE Philadelphia Councils Committee on Gas Works, at a meeting held early this month, have authorized Director Wagner to place 1,000 gas and 1,000 gasoline lamps in the county precincts during the year.

CERTAIN speculators who are attempting to secure a franchise for the operation of a fuel gas plant in St. Louis, propose to work under the Brazelle process. In support of their scheme they alleged that this process was in successful operation at the works of the Paris (Ills.) Gas Light and Coke Company. The President of that Company, when interviewed on the measure of success that had been gained in its operation of the Brazelle system, said: "The Brazelle process was in-

stalled at the works, having been operated experimentally for eight months, and then the gas was supplied to the city for about three months longer. The system is not even a partial success. The history of our connection with the Brazelle process is as follows: A small experimental apparatus had been erected, and the results from it appeared so promising that we determined to discontinue the manufacture of illuminating coal gas and distribute this fuel gas instead, relying upon an incandescent burner to give it luminosity. We were speedily obliged to give the plan up, as it was too expensive and uncertain. Then we attempted to carburet the gas by the addition of oil in the generator, but the attempt was a failure, for the added oil was partly burned out in passing with the gas down through the fuel, and partly deposited by the other extreme of temperature in the fire brick chamber which followed. After 'blowing up,' when the operation of gas making was going on, an explosion would frequently occur, of sufficient force to throw open the lids of the generators, or to loosen the fire brick linings in the same. A very stubborn clinker was formed by the down-draft; the coal used in the process was the same as that which gave us 8,000 cubic feet of good illuminating gas, when carbonized in retorts under the old process; but though Mr. Brazelle claimed to be able to obtain 60,000 feet per ton, he never did make over 11,000 feet, and often not more than 9,000 feet, and this a gas of no illuminating power whatever, and of far less heating value than the coal gas formerly made. Of course, with his process, we saved no tar nor coke, and the gas was consequently far more expensive than coal gas. Dr. Brazelle's method of estimating the yield per unit of coal was also rather peculiar. He first weighed the coal, then after the material had been burned, weighed the remaining ash, and charged the *difference* in weights as the amount of coal used. Even by this figuring he was unable to *make* over 11,000 cubic feet per ton. As a result of this change the only people in Paris who seemed satisfied with the Brazelle gas were the dentists, who found it to answer nicely in fusing their gold. For steam raising and the more extended uses of fuel it would not do at all. The consequence was that when, in January, 1890, the process was finally rejected, the Gas Company had to begin all over again, at a disadvantage much greater than that attending the operation of a new company; for not only had our former customers turned to the use of oil or electricity, but popular sentiment was very strong against us for the loss of the hitherto reliable heating and illuminating agent. After the rejection of this process we returned to making coal gas until a water gas plant of the Pratt & Ryan type was installed, and as this latter has been giving good satisfaction ever since, operated by the same workmen who attended the Brazelle apparatus, no claim of incompetent handling can be alleged in respect to the system that failed so much of Brazelle's 'success' at Paris, etc."

ONE of the substantial institutions of Clinton, Iowa, is to be found in the works and business of the Clinton Gas Light Company, which was incorporated 21 years ago, and which has since been in control of local capitalists. It is capitalized in \$65,000. About 300 consumers are on its rolls, the main mileage is 10; there are 75 public lamps, and the output last year was 6,119,000 cubic feet. Mr. Oliver Messer is Superintendent. The Company's business increases constantly, and it enjoys the confidence of the public.

AT the annual election of the Peoples (Jersey City, N. J.) Gas Light Company, the following Directors were chosen: F. Morris Perot, Thos. M. Williams, Thos. M. Gopsill, M. A. Cowisen, M. T. Newbold, Frank Stevens, Wm. Muirhead, Jas. L. Ogden and Geo. W. Conklin. The Directors subsequently indorsed the following executive management: President, F. Morris Perot; Vice-President, Thos. M. Gopsill; Secretary and Treasurer, E. N. Case.

AT the annual meeting of the Stockholders of the Easton (Pa.) Gas and Electric Light Company, the following Directors were chosen: General R. Thomas, M. M. Dawson, R. B. Dison, W. H. Thompson, T. Tunis, W. E. Shanahan, Col. O. Tilgiman, Jas. H. Covington, C. T. Wrightson and Jas. H. McNeal.

THE gas supply of Dalton (Ga.) is giving great satisfaction to the residents.

THE Directors of the San Francisco Gas Company have re-elected the following officers: President and Engineer, J. B. Crockett; Vice-President, Adam Grant; Secretary and Treasurer, W. G. Barrett.

THE Galesburg (Ills.) Gas Light and Coke Company's proprietors having decided to change their method of manufacture from coal to water

gas, have contracted with the National Gas Light and Fuel Company for a Springer apparatus having a capacity of 120,000 cubic feet per diem.

THE following figures and facts are taken from advance sheets of the annual report of Mr. Charles W. Hinman, Massachusetts State Inspector of Gas and Meters. During the past year 13,592 gas meters were inspected, of which number 13,412 were either new or recently-repaired instruments, 180 meters which had been in use some time, and which were suspected to be incorrect either by the consumer or the companies, were brought in for re inspection; of these 42 were found to be too fast, the average error being 5.65 per cent.; 121 were found to be within the legal limits—2 per cent.—16 were found to be too slow, with average error of 15.41 per cent.; and one meter did not register at all. The average error of meters that registered was 0.05 per cent. too slow. All the consumers' meters at present in use in the State are dry, and there is a gradual increase from year to year in the proportion of correct meters to the whole number complained of. The gas made by the various companies in the State has been inspected in the usual manner. Numerous analyses has shown that coal gas, as manufactured in Massachusetts, never contains as much as the legal limit of 10 per cent. of carbonic oxide. Comparing the results with those of last year, there is on the average found to be a slight falling off in the candle power of the gas of the larger companies. This decrease amounts to 0.11 of a candle power. The gas of two of the companies shows a decrease of about 1 candle each; but the lowest average among the larger companies is 2 candles above the legal standard of 15 candles. None of the other changes in the gas of these companies exceed about one-half of candle. The fluctuations in these candle powers have been more pronounced than last year; but the largest fluctuations have been at those places where a mixture of petroleum gas and water gas is used as an auxiliary to coal gas. It is desirable to keep the gas uniformly at one standard, as each grade of gas requires a different burner, or a new adjustment to produce the best result. The gas of the smaller companies has almost exactly the same average candle power as for the previous year, but there are a few considerable variations from the results of the previous years.

THE following terse letter explains itself:

“PORT HOPE (ONT.) GAS COMPANY, Feb. 10, 1890.

“To the Editor AMERICAN GAS LIGHT JOURNAL:—If a gas manager who has had experience in operating an electric light plant of, say, 50 arcs, and another who has about the same service in incandescent lamps, would, through your columns, give to their brother managers the benefit of that experience as to cost of installation, operating expenses and receipts, they would do a good service to their brethren now beset by electric light plant sellers whose statements are to be accepted with a grain of salt.

J. SMART, President.”

THE following officers have been chosen to manage the affairs of the New Britain (Conn.) Gas Light Company: President, G. M. Landers; Secretary and Treasurer, A. P. Collins; Superintendent, E. C. Learned; Directors, Geo. M. Landers, Wm. Bingham, L. F. Judd, Jas. H. Eddy and A. J. Sloper.

AT the annual meeting of the Independence (Mo.) Gas and Coke Company the following Directors were chosen: C. C. Chiles, L. P. Williamson, W. H. Waggoner, D. Bullard, W. M. McCoy, H. C. St. Clair, J. P. Alexander, R. D. Wirt and J. McCoy.

MR. J. E. MAYO, recently in charge of the Saratoga (N. Y.) Gas and Electric Light plants, has taken service with the Rockford (Ills.) Company.

THE property and franchise of the Corsicana (Tex.) Gas Light Company were disposed of at auction sale on the 4th inst. Messrs. Simkins & Niblett, local attorneys, representing a majority of the bonds, purchased the property. The Company will be reorganized. Our information is to the effect that this sale—the property had been in the hands of a receiver since last August—was brought about on account of legal complications involving the title to the property. We understand that the Company's business has been sufficient to yield a fair profit.

THE bill reducing the price of gas in St. Louis to 90 cents per 1,000 cu. ft. has passed both branches of the municipal legislature, and the posted division claim that Mayor Noonan will sign the ordinance. In the

meantime, however, it is of record that the Mayor believes the adoption by the Laclede Company of the old St. Louis Company's amended or substitute charter will prevent the city from carrying out the proposed attempt to regulate gas rates, at least for a term of years. It looks as though the matter will have to go through a very wearisome tangle of law ere the question is finally decided.

THE authorities of Cleveland, O., have been investigating the matter of public electric lighting, and a portion of the investigation consisted of the obtaining of figures from the authorities of other cities as to the rates paid for lighting the lamps in those cities. A compilation of the answers so far received is appended: New Orleans has 934 arc lights of 2,000-candle power, burning every night and all night. Of this number 634, in the city proper, cost \$125 a year; 262 suburban, \$146; 38 across the Mississippi, \$205. The city operates under a 5-year contract. For every lamp not lighted a pro rata reduction, with 10 per cent. added, is made from the monthly bills. The police report lamps not lighted. The entire city is lighted by electricity. Gas lamps per post before electricity was adopted were \$16. Cost of gas for city buildings is 1 cent per burner per hour. Fort Wayne, Ind., runs its lights on the Philadelphia or moon schedule, or all night, if the chief of police or chairman of the fire committee orders it. The lights are 2,000-candle power, and cost \$135 a year, with a reduction of 5½ cents an hour per light for any lights reported out by the police. Memphis burns 100 arc lights of 2,000-candle power, all night and every night, for \$187.50 a year. It pays \$20 a year for gas lamps, the same as Kansas City. Denver uses 1,100 20-candle power incandescent street lamps, which cost \$26 a year. For 2,000-candle power arc lights, all night and every night, it pays \$240 a year. For lamps burned on the moonlight schedule the cost is \$150 a year. No gas or gasoline lamps are used. At St. Paul only 54 arc lights are used. They burn until midnight at 35 cents a night. It pays \$2.46 a month for gas lamps, and has been paying \$25 a year for gasoline, but recent bids sent the gasoline prices down to \$16.80 a year. Omaha has just entered into a contract with the Thomson-Houston Company for lighting the city with 100 arc lights for 5 years at \$175 a year. The lamps are 2,000-candle power, to burn all night, and the electric light company to make all repairs. It has also made a 5-year contract for gas lamps to burn 5 feet of gas an hour, producing a 16 candle power light for \$25 a year. Gasoline lamps are \$19 a year. The Brush system is in use in Detroit, which city contains about the same area as Kansas City. It makes contracts for only a year at a time for lights, and has about six hundred 2,000-candle power lights, which cost \$140 a year to burn every night and all night. Buffalo has 1,223 arc lights, which cost 42½ cents per night for all night and every night. This is \$155.61½ a year. There are three systems used by the city, and the lights are lighted and extinguished by a printed schedule for each month. The city has 4,390 gas lamps burning 4 feet an hour, which cost \$17 each a year. The city of Milwaukee uses 270 arc lights of 2,000 candle power, burning each night and every night, for which it pays \$150 a year for each. Gas lamps cost \$24.70 a year, and gasoline, \$20. Quincy, Ills., goes by the moon schedule. It has one hundred and eighty-one 2,000-candle power arc lights burning when the moon does not shine, which cost \$100 a year each. It uses no gas or gasoline. St. Joseph has just completed an electric light plant and starts out with 210 arc lights, to cost \$6 a month, or \$70 a year—\$3 a year cheaper than St. Louis. The lamps are 2,000-candle power and burn all night and every night. Gas lamps cost \$15 a year, and gasoline, \$17. Pittsburg uses 300 arc lamps of 2,000-candle power, burning all night and every night, and pays \$105 a year. It also has 1,000 twenty-five-candle power incandescent street lights, which cost \$16 a year each. Gas lamps cost the same. In Kansas City, Kas., 96 arc lights of 2,000-candle power are furnished all night and every night at \$144 a year. The St. Louis contract is for 1,600 arc lights of 2,000-candle power, to burn all night and every night, at \$78 per year; 800 incandescent lights, of 30 candle power, at \$17.50 a year, and 800 of the same at \$20 a year.

MR. ROBERT J. DOBSON, who has been for the last 20 years connected with the Seneca Falls (N. Y.) Gas Light Company, under the late Wm. Parrish, has been appointed Superintendent and General Manager of the Company.

CURRENT rumor has it that the New Bedford (Mass.) Gas and Electric Light Company has absorbed the local Edison Electric Illuminating Company. It is understood that the basis of consolidation is 10 shares of the latter stock for 8½ shares of the former. This places the light supply of New Bedford entirely in the control of Mr. Taber's Company.

THE Louisville (Ky.) Gas Company is figuring in the local Law and Equity Court as defendant in a suit for damages (assessed at \$20,000) brought by a former employee—Peter M. Gillem. Plaintiff was employed as an ordinary laborer, and, on June 26, 1889, while moving a wheelbarrow loaded with brick, was injured through the toppling of a set scaffold. Gillem charges faulty construction.

THE Proviso (Ills.) Light and Water Company has been incorporated by Messrs. H. E. Broughton, Henry Struble and G. L. Thacher. It is capitalized in \$15,000. This place is a post township of Cook county, Ills., and is about 11 miles west of Chicago. Population about 6,500.

THE Gas Committee of the Kansas City (Mo.) lower branch of the local government recently held a session, at which certain matters affecting the Gas Company were discussed. Col. M. J. Payne, President of the Kansas City Company, spoke against the passage of the pending ordinance granting to an opposition gas company the right to lay pipes for the supplying of natural and manufactured gas for fuel purposes. Colonel Payne convinced the committee that his Company had been granted by the State Legislature an exclusive franchise for supplying the city and its inhabitants with gas of whatever sort. He also stated that the Company had expended nearly \$140,000 in constructing works for the purpose of supplying the city with fuel gas. "We have built a reservoir in the East bottoms," said Mr. Payne, "that will hold 1,000,000 cubic feet of gas. We have laid a 24-inch main from the city proper to it, which main is double the capacity of that which is now supplying the city with illuminating gas. We propose to base the cost of this fuel gas upon the price of a ton of coal, say at \$4 per ton." It was shown that Colonel Payne's Company had an exclusive franchise, and the committee therefore returned an adverse report upon the ordinance granting to George Sheidley and others the right to lay mains for supplying the city with natural and manufactured gas.

FOR its alkaline and vivid "cheekiness" the following action, taken last week by "District Assembly 41, Knights of Labor," of Baltimore, Md., will be appreciated. The "Knights," in debate on the bill now before the Maryland Legislature, under which it is proposed to regulate the gas supply of Baltimore, resolved, that while they considered it to the best interest of the community that the city should own its own gas plant, yet they recognized the great danger of placing any greater power in the hands of the municipal government until there has been secured the Australian system of voting and other necessary measures for the proper administration of public affairs. The resolutions stated that it is useless to ask for more than they could reasonably expect to secure. They claimed that as it appeared the Gas Company could make gas at 60 cents per 1,000 and pay interest on \$6,000,000 in bonds, therefore the Legislature ought to be called on to reduce the cost of gas 50 cents per 1,000 feet.

THE Dayton (Ky.) City Council is considering an ordinance under which it is proposed to grant to the Bellevue Gas and Light Company an exclusive charter, to last for 25 years.

On the Most Economical Engine for Small Power.

Professor J. E. Denton, in the last issue of the *Stevens' Indicator*, writing on the above-named subject, says:

A certain machine shop possesses two steam engines, one a plain slide-valve throttling 5½-inch bore by 7-inch stroke, the other an automatic cut-off, 7-inch bore by 14-inch stroke, both non-condensing. The shop required 7-horse power to run it, exclusive of the power to overcome the friction of the engine. The question arose whether it was cheaper to run the shop at 70 pounds boiler pressure with the plain slide-valve engine cutting off at three quarters, or with the 7-inch by 14-inch engine cutting off at one-fifth under the automatic action of its governor, or whether fuel would be saved by operating the engines on the compound principle, using the small engine as the high pressure cylinder and exhausting from it into the larger engine through a receiver, the system still being non-condensing. Both engines were carefully overhauled and made perfectly tight at their valve seats and pistons.

Each engine was then tested to determine the power absorbed to run itself, with the result that the small engine absorbed ¼-horse power, and the large engine 2½ horse power. The small engine was then made to perform 7¾ indicated horse power at 70 pounds boiler pressure and 146 revolutions per minute, the exhaust escaping into the atmosphere

at a back pressure of 17 pounds. The steam consumption per hour per horse power was 45 pounds.

The large automatic engine was then made to perform about the same indicated horse power at the same steam pressure and revolutions, the cut-off being about one-fifth. The steam consumption per hour per horse power was 35 pounds.

The same work was then performed by operating the engine on the compound system at the same boiler pressure and same cut-off in the small engine, and with 26 pounds receiver pressure and about one-half cut off in the larger engine, the exhaust passing into the atmosphere from the larger cylinder. The ratio of the cylinders made the ratio of expansion 4½, including clearances, or practically the same as the real ratio of expansion when the large engine was used alone, the clearance of the latter being 5 per cent. The steam consumption per hour per horse power was 33 pounds.

It follows from these results, that to obtain the 7 net horse power required to operate the shop, the indicated horse power for the three methods would be as follows:

System.	Friction.	Net Work.	Total or Indicated H.P.
Small engine	0.6	7	7.6
Large engine.....	2.5	7	9.5
Compound engine	3.1	7	10.1

The expense measured in steam consumed per hour will therefore be as follows:

Small engine.....	7.6 × 45 = 342 pounds.
Large engine.....	9.5 × 35 = 333 pounds.
Compound engine.....	10.1 × 33 = 333 pounds.

It is evident that so far as the coal consumed is concerned, the three methods are practically equal. The best method will therefore be the one which gives the least wear and tear, or the least trouble to apply, the first cost being too small in both cases to make interest a sensible factor.

This makes the most economical method that which derives the required power with the large engine alone, as the load upon it is only about half its working capacity, and, consequently, the wear and tear is very light; and, as a matter of fact, the engine has done the work for years with far less attendance and repairs than would be required if the small engine was made to perform the required work.

It is worthy of note that the greater proportional power required to overcome the friction of the automatic engine is due to the fact that its main shaft and flywheel, which cause the greater part of the friction, weigh much more in proportion to the total mean pressure on its piston than is the case with the small engine.

Electric Light at the British Museum.

In the galleries on the ground floor there are 69 arc lamps of various powers, while on the upper floors there are 57 arc and 627 glow lamps. In addition to these there are 5 large arc lamps in the reading room, 6 in the courtyard, and upwards of 200 glow lamps in the offices and passages. The total current required to work the whole of the lamps is nearly 1,200 amperes, with an E.M.F. of 115 volts at the lamp terminals; and this output is produced by the expenditure of nearly 200-brake horse power. The current is generated by four Siemens dynamo machines, each capable of giving an output of 450 amperes and 130 volts, which are connected to a general switchboard in the engine room by means of which they can be put to work in parallel to any or all of the circuits.

The switchboard is fitted with instruments indicating the current given off by each dynamo, and four circuits are led from it round the Museum—two for the upper and two for the lower floor. The main wires are laid outside of the building.

In order to insure safety, and to guard as far as possible against failure of light, the motive power is in duplicate. The four dynamos are driven in pairs, each pair by a separate engine with a separate counter-shaft. Each engine has a separate steam pipe in direct communication with the boilers, and there is an ample reserve of boiler power.

The power of the engines and dynamos is so adjusted that each of the two sets is capable of working the whole of the lamps in those galleries proposed to be lighted on any one evening; the other set standing by ready to work. Further, in order to work, if required, at half-power, or in order to provide half-light for the whole of the galleries—which light should suffice for an emergency, such as sudden fog or accident—the lamps are connected in pairs alternately, so that half of the number being cut off, the light of the other half still remains evenly distributed.



A. M. CALLENDER & CO.,

PROPRIETORS.

EDITOR—Jos. R. Thomas, C.E.

ASST. EDITOR—T. J. Cunningham.

MANAGER—C. E. Sanderson.

PUBLISHED ON EACH MONDAY OF THE YEAR AT No. 42 Pine Street, New York.

This is a recognized official organ of LIGHT, HEAT, STEAM, WATER SUPPLY, VENTILATION, SANITARY IMPROVEMENT, AND GENERAL SCIENCE

TERMS:

SUBSCRIPTION—Three Dollars per annum, in advance. Single copies, 10 cents.

AGENTS.

NEW YORK.—AMERICAN NEWS CO., 39 and 41 Chambers Street. PHILADELPHIA—PRATT & CO., Corner Ninth and Arch Streets. Germany.—B. WESTERMANN & CO., of New York.

MONDAY, FEBRUARY 17, 1890.

Gas Stocks.

Quotations by Geo. W. Close, Broker and Dealer in Gas Stocks, 16 WALL ST., NEW YORK CITY.

FEBRUARY 17.

All communications will receive particular attention. The following quotations are based on the par value of \$100 per share.

Table of Gas Stocks with columns for Company Name, Capital, Par, Bid, and Asked prices.

Out of Town Gas Companies.

Table listing Boston United Gas Co. and other out-of-town companies with their stock details.

Table listing various gas companies and their financial details, including Bay State Gas Co., Buffalo Mutual, Citizens, Chicago Gas Trust, etc.

Advertisers Index.

Table listing advertisers under categories: GAS ENGINEERS, GAS AND WATER PIPES, GAS WORKS APPARATUS AND CONSTRUCTION.

Table listing various industrial processes and equipment under categories: PROCESSES, INCLINED RETORTS, GASHOLDER TANKS, GASHOLDER PAINT, RETORTS AND FIREBRICK, SCRUBBERS AND CONDENSERS, REGENERATIVE FURNACES, GAS GOVERNORS, SELF-SEALING MOUTHPIECE DOORS, TAR AND CARBONIC ACID EXTRACTOR, CEMENTS, GAS ENRICHERS, GAS METERS, EXHAUSTERS, GAS COALS, CANNEL COALS, VALVES, GAS ENGINES.

ENGINES AND BOILERS.

Jarvis Engineering Co., Boston, Mass..... 227
 Ball Engine Co., Erie, Pa..... 220
 Westinghouse Machine Co., Pittsburgh, Pa..... 231

GAS LAMPS.

G. Shepard Page, New York City..... 228
 Standard Gas Lamp Co., Phila., Pa..... 220
 Welsbach Incandescent Gas Light Co., Phila., Pa..... 221
 The Siemens-Lungren Company, Philadelphia, Pa..... 221

PURIFIER SCREENS.

John Cabot, New York City..... 228
 Bartlett, Hayward & Co., Baltimore, Md..... 228

GAS STOVES.

American Meter Co., New York and Philadelphia..... 229
 The Goodwin Gas Stove and Meter Co., Phila. Pa..... 247
 George M. Clark & Company, Chicago, Ills..... 221
 D. McDonald & Co., Albany, N. Y..... 231
 Maryland Meter and Manufacturing Co., Baltimore, Md. . . 238
 Bell & Jones, Philadelphia, Pa..... 228

STREET LAMPS.

J. G. Miner, Morrisania, New York City..... 184
 Bartlett Street Lamp Man'g Co., New York City..... 220

BURNERS.

C. A. Gefrorer, Phila., Pa..... 236

STEAM BLOWER FOR BURNING BREESE.

H. E. Parson, New York City..... 192

PURIFYING MATERIAL.

Connelly & Co., New York City..... 227
 Friedrich Lux, London, England..... 219
 Edgewater Lime Works, Edgewater, N. J..... 219

COKE CRUSHER.

C. M. Keller, Columbus, Ind..... 237

ELECTRICAL APPARATUS.

Wm. Henry White, N. Y. City..... 235

SOLVENTS.

Maas & Waldstein, New York City..... 227

BOOKS, ETC.

Gerould's System Gas Bookkeeping..... 219
 1889, Directory. 1889..... 230
 King's Treatise..... 232
 Scientific Books..... 202
 Management of Small Gas Works..... 228
 Gas vs. Electricity..... 220
 Practical Electric Lighting..... 227
 Electric Light Primer..... 227
 American Gas Engineer and Superintendents' Handbook... 237
 Digest of Gas Law..... 219
 Fuel and its Applications..... 219

POSITION WANTED

As Manager of a Gas Works

Making from 5 to 10 million cubic feet per annum. Six years' experience. Address "J. M. M.," 767-4 Care this Journal.

POSITION WANTED.

A Mechanical Engineer,

Experienced in Gas Manufacture, wishes a position as Superintendent of a Gas Works. Best of references given and asked. Salary, \$1,200.

"MECHANICAL ENGINEER," care this Journal, 765-1f or Box 972, West Bay City, Mich

Position Wanted

As Superintendent or Assistant of a Gas Works,

By a man who can give the best of references. Thoroughly understands the manufacture and distribution of gas and the construction of works. Address 765-5 "M.," care this Journal.

FOR SALE.

A Complete Water Gas Plant. 60,000 Cu. Ft. Daily Capacity.

Fully equipped; all the latest improvements; includes Generator, Purifiers, and Holder. Can be removed to any part of the country, and set up at small cost. For further information apply to BRADFORD GAS LT. & HEATING CO., Dunkirk, N. Y.

FOR SALE.

We offer the following gas apparatus for sale, delivered f.o.h. cars Fort Worth, Texas:

Two Benches of 3's, with cast iron Hydraulic Main, Dip and Ascension Pipes, and Mouthpieces (14 by 23 in.).
One Bench of 6's, with cast iron Hydraulic Main, Dip and Ascension Pipes, and Mouthpieces (12 by 20 in.).
Two Benches of 3's, with cast iron Hydraulic Main, Dip and Ascension Pipes, and Mouthpieces (14 by 24 in.).
Four Purifiers, 6 ft by 6 ft., with 6-in. Connections and Center Seal. **Steam Jet Exhauster. One Set Pipe Condensers** (6-in.). **One Upright Scrubber**, 11 ft. high by 36 in. diam., with Bye-Pass. **One Station Meter**, daily capacity 100,000 cu. ft. **One Upright Boiler**, 20 horse power.

All of above apparatus in first-class condition and are so guaranteed. For further particulars address

FORT WORTH LT. AND POWER CO.,

767-4

Fort Worth, Texas.

GAS WORKS FOR SALE.

A CONTROLLING INTEREST IN SEVERAL

Interior California Coal Gas Plants,

now paying handsomely, are offered on very reasonable terms. This is an exceptionally good opportunity for practical gas men of limited means, wishing to remove to a mild and healthful climate, to acquire an established and paying business. Particulars given and full investigation solicited.

SECRETARY, 123 Beale Street,

760-3 mos.

San Francisco, Cal.

FOR SALE,

One 5-ft. Station Meter.

One Hydraulic Main (five sections), wrought iron, 22 by 24, with Bye-Pass on Dip-Pipes.

25 Valves, Stand-Pipes, 7-inch Mouthpieces and Lids, all complete, ready for use, to fit up five benches of 5's.

This apparatus is all in first-class condition.

Price, \$800, f.o.h. cars or boat, Poughkeepsie, N. Y.

Inquiries may be sent to this Office.

6 PER CENT.

First Mortgage Bonds

ON GAS WORKS

SITUATED IN GROWING WESTERN TOWNS.

Principal and Interest Guaranteed.

INTEREST SEMI-ANNUALLY.

For sale by the undersigned, who will furnish all necessary information regarding them.

JOS. R. THOMAS, 42 Pine St., N. Y. City.

FRIEDRICH LUX,

Ludwigshafen am Rhein and London.

Lux Mass

GAS GOVERNORS,

Gas Balance.

Fuel and Its Applications.

By E. J. MILLS, D.Sc. F.R.S., and F. J. ROWAN, C.E., assisted by others, including Mr. F. P. Dewey, of the Smithsonian Inst., Wash., D. C.

7 PLATES, AND 607 OTHER ILLUSTRATIONS. ROYAL OCTAVO, PAGES XX, 802. HANDSOME CLOTH, \$7.50.

A. M. CALLENDER & CO., 42 Pine St., N. Y.

GEROULD'S

System Gas Bookkeeping.

Approved and adopted by many of the prominent Gas Engineers of the Country.

Sample Sheets and Price-List furnished free on application to

L. P. GEROULD, - - Mendota Ill.

EDGEWATER LIME WORKS

Chas. F. McKenna, Proprietor.

SHELL LIME.

Lime by the Cargo for Gas Purification.

EDGEWATER, BERGEN CO., N. J.

Write for Testimonials and Prices.

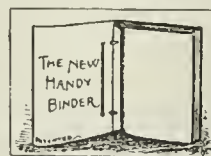

THE NEW HANDY BINDER.

This article may be described as elegant in appearance, strong, durable, and possessing many special qualities of its own. It allows the opening of the pages perfectly flat, whether one or several numbers are in the binder. Any number can be taken out and replaced without disturbing the others. The papers are not mutilated for subsequent binding in permanent form. The binder is supplied with gilt side title, and is an ornament to any desk or reading table. The JOURNAL, filed in the Handy Binder, becomes a volume of great value, always convenient for instant reference. Handy Binder, Postage paid, \$1.00.

A. M. CALLENDER & CO., 42 Pine St., N. Y.

GREENOUGH'S

"DIGEST OF GAS LAW."

Price, \$5.00.

This is a valuable and important work, a copy of which should be in the possession of every gas company in the country, whether large or small. As a book of reference it will be found invaluable. It is the only work of the kind which has ever been published in this country, and is most complete. Handsomely bound. Orders may be sent to

A. M. CALLENDER & CO.,
 42 Pine Street, N. Y.

GASHOLDER PAINT.

Use Only

THE GOVERNMENT WATERPROOF PAINT.

Proof against Ammonia, and Absolutely Waterproof. Send for Prices and Particulars.

THE GOVERNMENT WATERPROOF PAINT CO., 122 Milk Street, Boston, Mass.

F. D. HARMON, PRES.

CHAS. C. ALLEN, SEC. AND TREAS.

P. W. MACKENZIE, CHIEF ENGR. & SUPT.

THE FUEL GAS AND LIGHT IMPROVEMENT CO.

OF AMERICA.

Owners of the RECENT Mackenzie Patents,

For the United States, England, Russia, France, Germany, Austria, and Canada,

No. 32 Park Place, New York City.

This SYSTEM is an ABSOLUTELY NEW DEPARTURE IN THE MANUFACTURE OF FUEL AND ILLUMINATING GAS. The COST OF GAS IN THE HOLDER by our System is at least THIRTY PER CENT. LESS than that made by any other process of the day.

The Gas is manufactured WHOLLY from LIQUID HYDROCARBONS, such as Lima, Penn, Crude, and Fuel Oils, Naphtha, etc.

Neither PERISHABLE PIPES or other RETORTS, NOR THEIR EQUIVALENTS, are used.

Neither COAL, COKE, nor any other HARD CARBONS enter into the manufacture or composition of the Gas, thereby requiring LESS LABOR THAN ANY OTHER METHOD.

The Gas contains neither SULPHUR nor other impurities, nor is there any resultant LAMPBLACK OR TAR RESIDUUM.

The Gas requires NO PURIFICATION whatever.

The FUEL GAS COSTS VERY MUCH LESS than PURE UNCARBURETED WATER GAS, and contains DOUBLE THE HEAT UNITS.

The APPARATUS is extremely SIMPLE, SUBSTANTIAL, and DURABLE, and consists of a Single Body with a capacity of ONE THOUSAND to ONE HUNDRED THOUSAND cubic feet per hour.

Works may be constructed to run by the CONTINUOUS or ALTERNATING method. If run continuously, the limited amount of Nitrogen present is neutralized by Carbon.

The Gas can be made of a HIGH GRADE for illuminating purposes, of a MEDIUM QUALITY for distribution for domestic purposes, and of a LOW GRADE for manufacturing uses.

Wherever Liquid Hydrocarbons can be had the MACKENZIE PROCESS WILL COMPETE IN PRICE AND SUPPLY ALL THE ADVANTAGES incidental to the use of NATURAL GAS.

This Company desires contracts for the construction of Plants, parts of Plants, Apparatus, Buildings, Holders, and Street Mains, for either of the above purposes, and will Lease or Purchase Works upon satisfactory terms.

Information will be promptly given regarding material required for production of Gas, actual cost of product, cost of works, etc.

Bartlett Street Lamp Mfg. Co.

MANUFACTURERS OF

Globe Lamps,

FOR

Streets, Parks, Public Buildings, Railroad Stations, etc.

LAMP POSTS

A Specialty.

Office and Salesroom,

40 & 42 COLLEGE PLACE, - - N. Y. CITY.

Gas Companies and others intending to erect Lamps and Posts will do well to communicate with us.



No. 29 Champion.

BALL AUTOMATIC CUT OFF ENGINE
MADE ONLY BY THE BALL ENGINE CO. ERIE PA.

PATENTS.

FRANKLIN H. HOUGH
Solicitor of American & Foreign Patents.

925 F. ST., WASHINGTON, D. C.

(NEAR U. S. PATENT OFFICE.)

Personal attention given to the preparation and prosecution of applications for Letters Patent. All business before the U. S. Patent Office attended to for moderate fees. **No Agency in the United States possesses superior facilities for obtaining Patents**, or for ascertaining the patentability of inventions. Copies of patents furnished for 25 cents each. Correspondence solicited.

GAS vs. ELECTRIC LIGHT.

We would invite attention to the able and exhaustive argument of General A. Hickenlooper, President of the Cincinnati Gas Light and Coke Company, contained in a handsome pamphlet of 96 pages, entitled

"EDISON'S INCANDESCENT ELECTRIC LIGHTS FOR STREET ILLUMINATION. REPORT OF AN ARGUMENT DELIVERED BY A. HICKENLOOPER BEFORE THE COMMITTEE ON LIGHT, MUNICIPAL COUNCIL, CITY OF CINCINNATI, JULY 22, 1886."

This is a subject of special interest to all Gas Light Companies.

Prices.

25 copies.....	\$7.50	100 copies.....	\$22.50
50 copies.....	12.50	250 copies.....	50.00

A sample copy will be sent by mail on receipt of 50 cts
A. W. CALLENDER & CO., 42 PINE ST., N. Y. CITY

Simpkin & Hillyer

RICHMOND, VA.

MANUFACTURERS OF

Gas Works Apparatus

BENCH CASTINGS, CONDENSERS,

Scrubbers, Purifiers, Dry Center Seals,

FOUR-WAY VALVES, GAS VALVES,

SULPHATE OF AMMONIA APPARATUS,

TANKS, ENGINES, BOILERS,

PUMPS, ETC., ETC.

Plans, Specifications and Estimates furnished for new works, or alteration of old works. Correspondence solicited. Works, Newport News, Va.

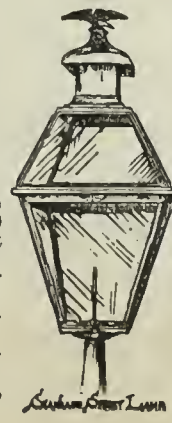

PHILADELPHIA.

NEW YORK.

CHICAGO.

STEPHEN A. MORSE, President.
GODFREY REBMANN, Vice-Pres.

EDWIN F. MORSE, Secretary.
CARLTON M. WILLIAMS, Treas.

STANDARD GAS LAMP CO.,

Main Office, 411 Cherry St. Factory, 1101, 1103, 1105 Frankford Av.

PHILADELPHIA, PA.

It is to the interest of Gas Companies and Cities to double the efficiency of the light on streets by using Dyott's Patent "CHAMPION" LAMPS. They save 50 per cent. over others in cost of repairs, are ornamental, and indestructible except by violence.

Our Patent System of Instantaneously Lighting Gas (without electricity), for Railroad Depots is unequalled.

Dyott's High Candle Power Burner is a very superior lamp where a concentrated and brilliant light is wanted in Hotels, Stores, Depots, etc.

Special Drawings furnished and Estimates cheerfully given, either from Architects', Engineers', or our Draughtmen's Plans.

We manufacture every description of Plain and Ornamental Lamps, Posts, Brackets, Clusters, etc. Correspondence solicited.

The Gordon Portico Lamp.

A successful Competitor of the Arc Electric Light for lighting Store Fronts, Show Windows, Depots, Railway Sheds, etc., etc.

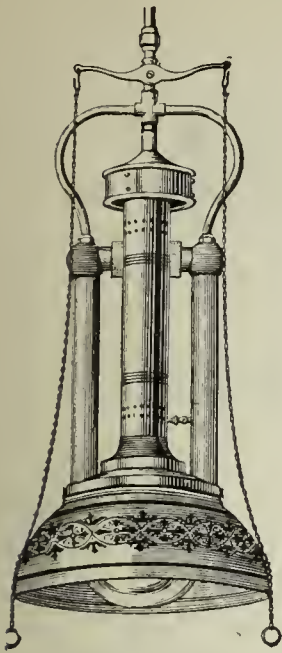

Gordon Portico Lamp.

The Gordon Street Lamp.

A Successful Competitor of the Arc Electric Light for lighting Streets, etc., etc.

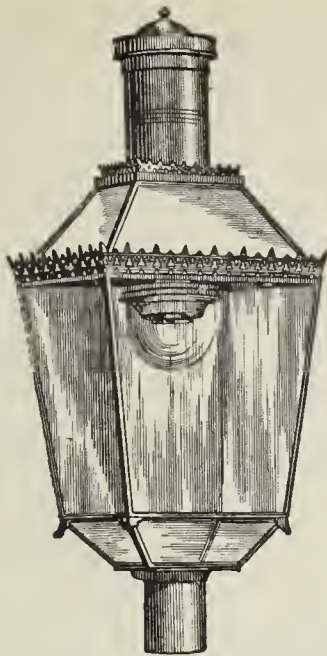

Gordon Street Lamp.

The Lungren Lamp.

A Successful Competitor of the Incandescent Electric Light for Interiors, etc. Is especially applicable for the lighting of Offices, Stores, Factories, Mills, Show Windows, Libraries, and all situations where an increased illumination is desired.

More than 25,000 Lungren Lamps are now in use. Testimonials, references, or any desired information will be cheerfully given.



Lungren Lamp.

THE SIEMENS-LUNGREN CO., N.E. Cor. 21st St. & Washington Av., PHILADELPHIA.

WELSBACH SYSTEM OF Incandescent Gas Lighting.

OFFICE, DREXEL BUILDING, PHILA., PA.

At the Fall Session of the Board of Supervisors of Winnebago County, held at the County Court House, Oshkosh, Wis., Nov. 26, 1889, the report submitted by Mr. C. W. Cook, Chairman of the Committee on Public Buildings, recommending the use of the Welsbach Incandescent Gas Burner in the Buildings under their charge, was unanimously adopted, because of the extreme economy in the consumption of Gas and the superior character of the light obtained.

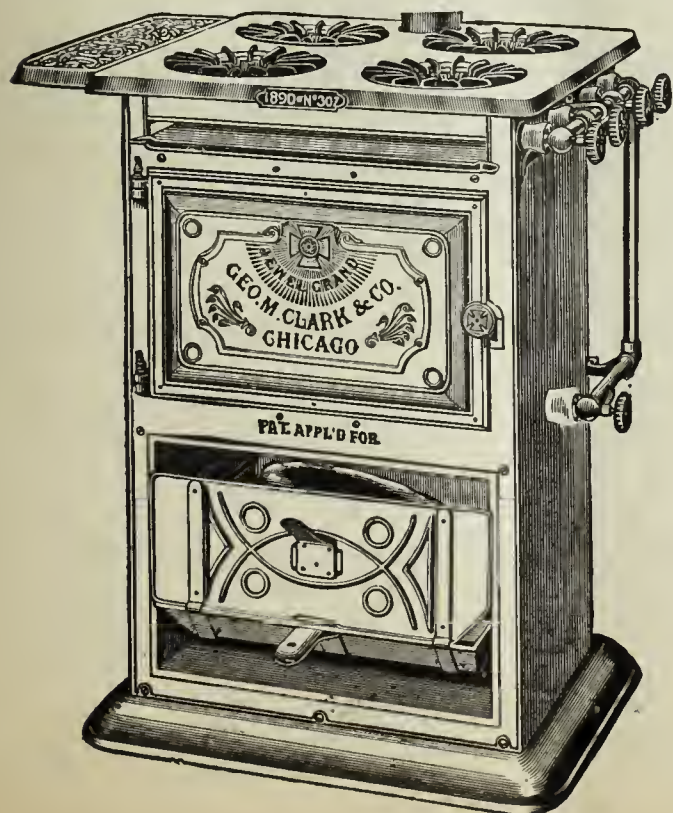

JEWEL GAS STOVES

MANUFACTURED BY

GEORGE M. CLARK & COMPANY,

Nos. 157 & 159 Superior Street, - - - Chicago, Ill.

EVERY CONCEIVABLE SIZE AND STYLE,

Ranging in Prices from \$1.50 to \$30.00.

WE USE NO GAS COCKS.

All Flames are Regulated by a Direct Needle Valve.

The JEWEL

IS THE

Only Well-Made Gas Stove on the Market.

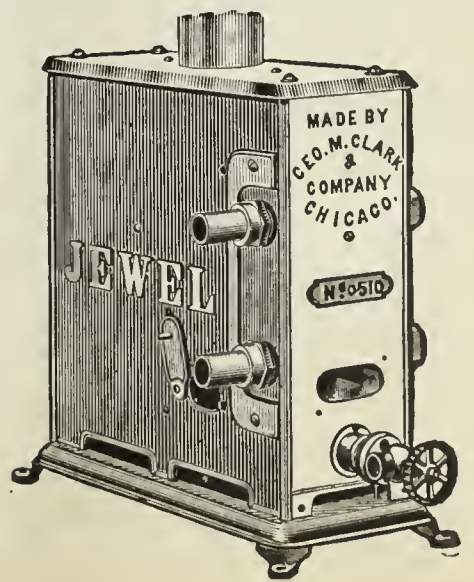

Write for our 1890 Catalogue and see for yourself.

ROOTS' NEW GAS EXHAUSTER.

Unsurpassed
for Neatness
of Design,
Durability,
Simplicity,
Efficiency,
and Economy
of Power.

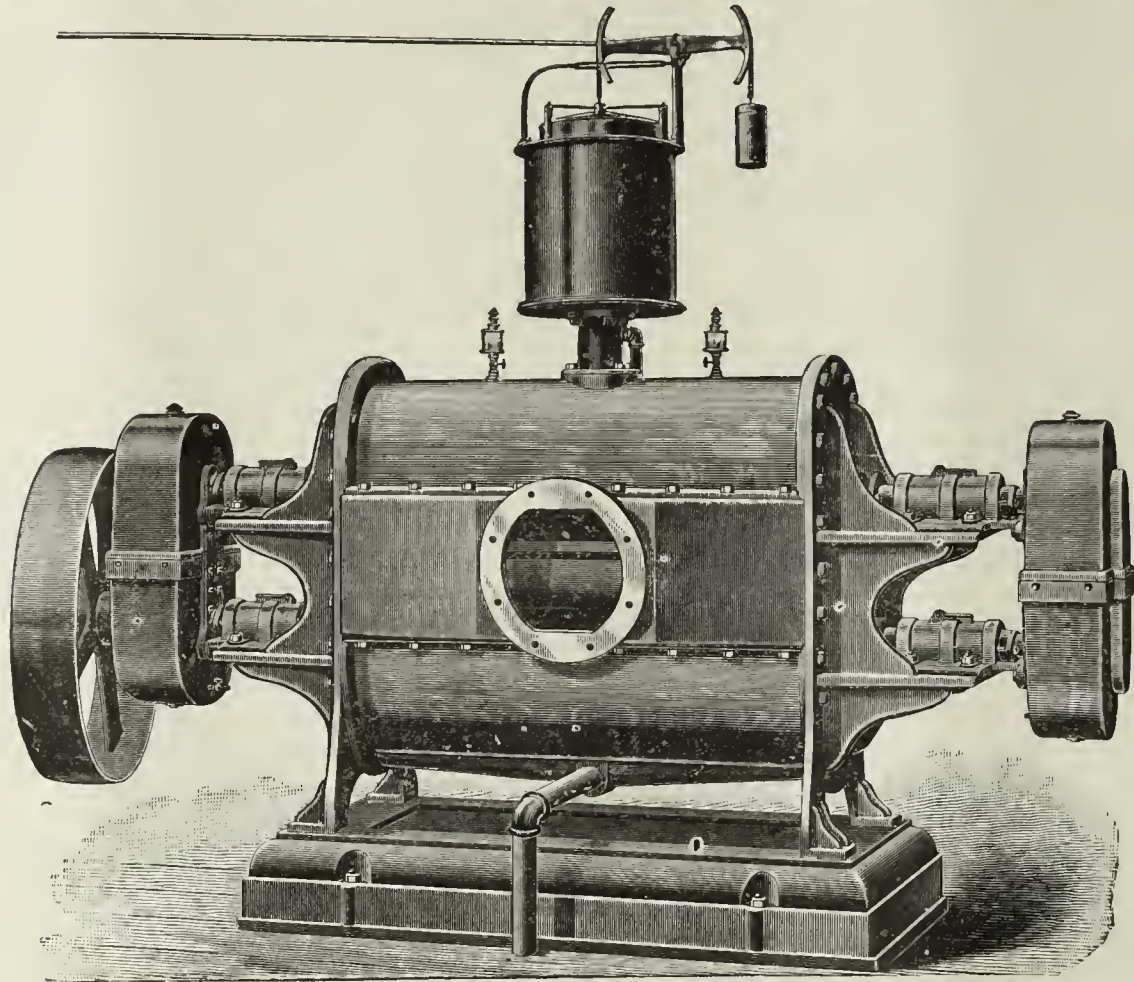

All Parts
Requiring
Attention
are External
and Easily
Accessible
at all Times.

ROOTS' GAS AND BYE-PASS VALVES.

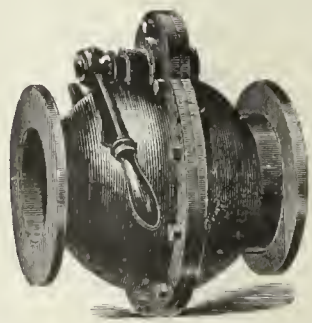

GAS VALVE

Quick Acting,
Simple,
Efficient, Durable.



BYE-PASS VALVE.

Automatic Action,
Reliable,
Simple, Durable.

Thousands now in use and giving perfect satisfaction. Write for Catalogue and Prices.

Send for Descriptive Catalogue and Price List.

THE P. H. & F. M. ROOTS CO., Patentees and Manufacturers, **CONNERSVILLE, IND.**

S. S. TOWNSEND, Gen. Agt., 22 Cortlandt St., N. Y.

COOKE & CO., Selling Agts., 22 Cortlandt St., N. Y.

THIS SPACE
WILL BE
Occupied Next Month by the
KERR MURRAY MFG. CO.
FORT WAYNE, IND.
**GAS WORKS
APPARATUS
AND
HOLDERS.**

**DAVIS & FARNUM MFG. CO.,
WALTHAM, MASS.**

PRINCIPAL OFFICE AND WORKS, Waltham, Mass.

BOSTON OFFICE, Room 55, Mason Building, 70 Kilby Street.

SINGLE, DOUBLE,
AND
TRIPLE LIFT

Gas holders.

OF ANY CAPACITY.

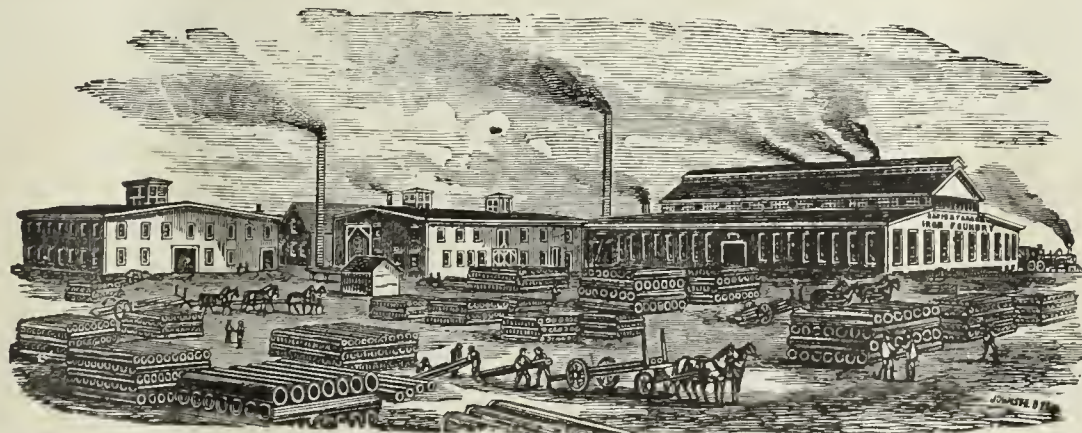

TUBULAR, PIPE,
AND
SINUOUS FRICTION

Condensers.

OF ALL SIZES.

IRON ROOF FRAMES AND FLOORS.
Purifying Boxes, Center Seal or Valve Connections, Bench Work.
Reversible Lime Trays.

SELF-SEALING AND PRESSED STEEL MOUTHPIECE LIDS.

Coke Barrows, Coal Wagons, and all Apparatus Requisite for a Complete Gas Plant.

— ALSO —

Gas and Water Pipe, Flanged Pipe,

Sugar House Work, and Special Castings of all Descriptions.

THE WALKER TAR AND CARBONIC ACID EXTRACTOR.

A very general demand exists, in both large and small Gas Works, for an apparatus that will be absolutely efficient in the removal of the tar which passes the hydraulic main and condenser. Many attempts have been made to accomplish this, but, I believe, without success, until the introduction, five years ago, in England, of the C. & W. Walker Patent Tar and Carbonic Acid Extractor. During these years this apparatus has been adopted by many of the most prominent Engineers, not only in England, but also on the Continent of Europe and in other parts of the world. It is only necessary to give here a partial list in order to convince any intelligent American Gas Engineer that this machine must have succeeded fully in accomplishing the desired results.

The following Engineers have personally given permission to refer to them:

G. C. Trewby, Esq., Engineer-in-Chief of the Gas Light and Coke Co., London. The manufacturing plant at Beckton is built in complete sections of 3,000,000 cubic feet capacity each. A Walker Tar Extractor has been fitted to each one of these sections. This was done after a long and thorough trial on one of its sections. The Tar Extractor has been supplied to other works of the Gas Light and Coke Co., including those of which John Methven, Engineer of the Gas Light and Coke Co. at the Nine Elms Station, is in charge. Also to G. E. Stevenson, Peterborough Gas Works; B. Green, Mitcham and Wimbledon Gas Works; W. H. Smith, Bedford Gas Works; F. Linging, Norwich Gas Works; J. T. Browning, Colchester Gas Works; S. B. Darwin, Portsmouth Gas Works; J. McCrae, Dundee Gas Works; W. J. Wells, Stamford Gas Works; J. M. Darwin, Longton Gas Works; J. Paterson, Warrington Gas Works; and J. Coulter, of the Dundalk Gas Works. All of the foregoing gas works are located in Great Britain.

Mr. Charles A. Gerdenier, Superintendent of the Bridgeport (Conn.) Gas Light Company, writes as follows, under date of Dec. 3, 1887:

"The C. & W. Walker Tar and Carbonic Acid Extractor has been in operation at these works for the past six weeks, and is an unqualified success. It removes every particle of Tar from the gas in once passing through the apparatus, and a large percentage of the Carbonic Acid. I also feel quite sure that it prevents the formation and deposit of Naphthaline, because since I started the Washer I have had no stoppages from this cause. These works have been seriously troubled with Tar for many years, and I have used several kinds of apparatus and every expedient which has come to my attention for dealing with the difficulty, but without success. The Walker apparatus occupies comparatively small space, is less expensive than other systems, and requires but little attention. I carry 2½-inch seal, and have an automatic tar delivery valve. This Tar Extractor is indispensable to gas makers."

I have taken the Agency for the United States for this apparatus, and am now prepared to make contracts to erect it on the premises of any Gas Company. It would be manufactured in the following sizes:

No.	Capacity (cu. ft.)	Dimensions (ft.)
No. 1,	50,000 to 100,000	3 ft. square, 5 ft. deep.
No. 2,	" " 125,000	4 " " " "
No. 3,	" " 250,000	5 " " " "
No. 4,	" " 500,000	6 " " " "
No. 5,	" " 750,000	7 " " " "
No. 6,	" " 1,000,000	8 " " " "
No. 7,	" " 1,250,000	9 " " " "
No. 8,	" " 1,500,000	10 " " " "
No. 9,	" " 2,000,000	12 " " " "
No. 10,	" " 3,000,000	15 " " " "

This Tar Extractor will perform its work with about one-fourth the usual back-pressure heretofore required. It is simple in construction, and can be supplied at a very reasonable price—less than any other ever before introduced. Satisfactory results will be guaranteed in every instance.

GEO. SHEPARD PAGE,

SOLE AGENT FOR THE UNITED STATES,

No. 69 Wall Street, - - - New York.

THE UNITED GAS IMPROVEMENT CO.

DREXEL BUILDING, PHILADELPHIA.

OFFICERS:

WILLIAM W. GIBBS, President.

GEORGE PHILLER, Vice-President.

SAM'L T. BODINE, Gen'l Manager.

RANDAL MORGAN, Gen'l Counsel.

EDWARD C. LEE, Sec'y and Treas.

ALEX. C. HUMPHREYS, Gen'l Supt.

WALTON CLARK, Ass't Gen'l Supt.

H. H. EDGERTON, Chem. and Eng'r.

DIRECTORS:

GEORGE PHILLER,

THOMAS DOLAN

HENRY C. GIBSON,

WM. T. CARTER,

WILLIAM G. WARDEN,

SAM'L T. BODINE.

BUILDERS, LESSEES AND PURCHASERS OF

➤ GAS WORKS. ➤

Orders solicited from Large Cities, Small Towns, Mills, Institutions, from all who want more Light for Less Money.

NATIONAL GAS LIGHT AND FUEL COMPANY,

No. 218 La Salle Street, Chicago.

THE SPRINGER SYSTEM

OF

Fuel and Illuminating Water Gas Works.

REFERENCES.

People's Gas Lt. & Coke Co..Chicago, Ill.
 Illinois Light, Heat & Power
 Co.....Chicago, Ill
 Elgin National Watch Co...Elgin, Ill.
 C. R. I. & P. R. R. Shops..Chicago, Ill.
 Decatur Gas Lt & Coke Co..Decatur, Ill.
 Niles Gas Light Co.....Niles, Mich.
 Newton Illuminating Co...Newton, Kansas.
 Wellington Light & Heat Co..Wellington, Kansas.
 Chippewa Falls Gas Lt. Co..Chippewa Falls, Wis.
 Elkhart Gas Lt & Coke Co..Elkhart, Ind.
 Madison City Gas Light Co.Madison, Wis.
 South Bend Gas Light Co..South Bend, Ind.
 Sheboygan National Gas Co.Sheboygan, Wis.
 Salina Gas Light Co.....Salina, Kansas.
 The Rathbun Co.....Deseronto, Prov.Ont.
 Jefferson City Gas Lt. Co..Jefferson City, Mo.
 Mankato Gas Light Co.....Mankato, Minn.
 Lima Gas Light Co...Lima, Ohio.

Minneapolis Gas Light and
 Coke Co.....Minneapolis, Minn.
 Bellevue Water and Fuel } Bellevue, Campbell
 Gas Light Co..... } County, Ky.
 Bucyrus Gas Lt. & Fuel Co.Bucyrus, Ohio.
 Morris Gas Co.....Morris, Ill.
 Los Angeles Gas Co.....Los Angeles, Cal.
 San Diego Gas Fuel & Elec-
 tric Lt. Co.....San Diego, Cal.
 Sioux Falls Gas Co.....Sioux Falls, Dak.
 Dakota Gas and Fuel Co..Grand Forks, Dak.
 St. Johns Mutual Gas Co..St. Johns, Mich.
 Stillwater Gas Light Co...Stillwater, Minn.
 St. Paul Gas Light Co.....St. Paul, Minn.
 Emporia Electric and Gas
 Light Co.....Emporia, Kas.
 Van Wert Gas Light Co...Van Wert, Ohio.
 Lansing Gas Light Co.....Lansing, Mich.
 San Francisco Gas Lt. Co..San Francisco, Cal.

Shelbyville Gas Light Co...Shelbyville, Ind.
 Great Falls Gas Light Co..Great Falls, N. H.
 Belleville Gas Co.....Belleville, Ontario
 Rochester Lt. and Fuel Co..Rochester, Minn.
 Northwestern Gas Light and
 Coke Co.....Evanston, Ill.
 Lincoln Gas Light Co.....Lincoln, Neb.
 Davenport Gas Light Co...Davenport, Iowa.
 Municipal Gas Co.....Albany, N. Y.
 Alliance Gas Light Co.....Alliance, Ohio.
 New Gas Light Co.....Janesville, Wis.
 Chicago Gas Lt. & Coke Co., Chicago, Ill.
 Joliet Gas Co.....Joliet, Ills.
 Superior Light & Fuel Co..Superior, Wis.
 Kewanee Gas Light Co...Kewanee, Ill.
 Aberdeen Light & Fuel Co..Aberdeen, So. Dak.
 Pierre Light and Fuel Co..Pierre, So. Dak.
 *Standard Gas Light Co...New York City.
 *Carlinville Gas Light Co..Carlinville, Ill.

* Building.

GUARANTEED ESTIMATES of Cost of Gas Furnished on Application.

GASHOLDER TANK CONSTRUCTION, ETC.

Gas Companies and others about to erect Gasholders will find it profitable to consult W. C. Whyte, who for over 30 years has made a specialty of

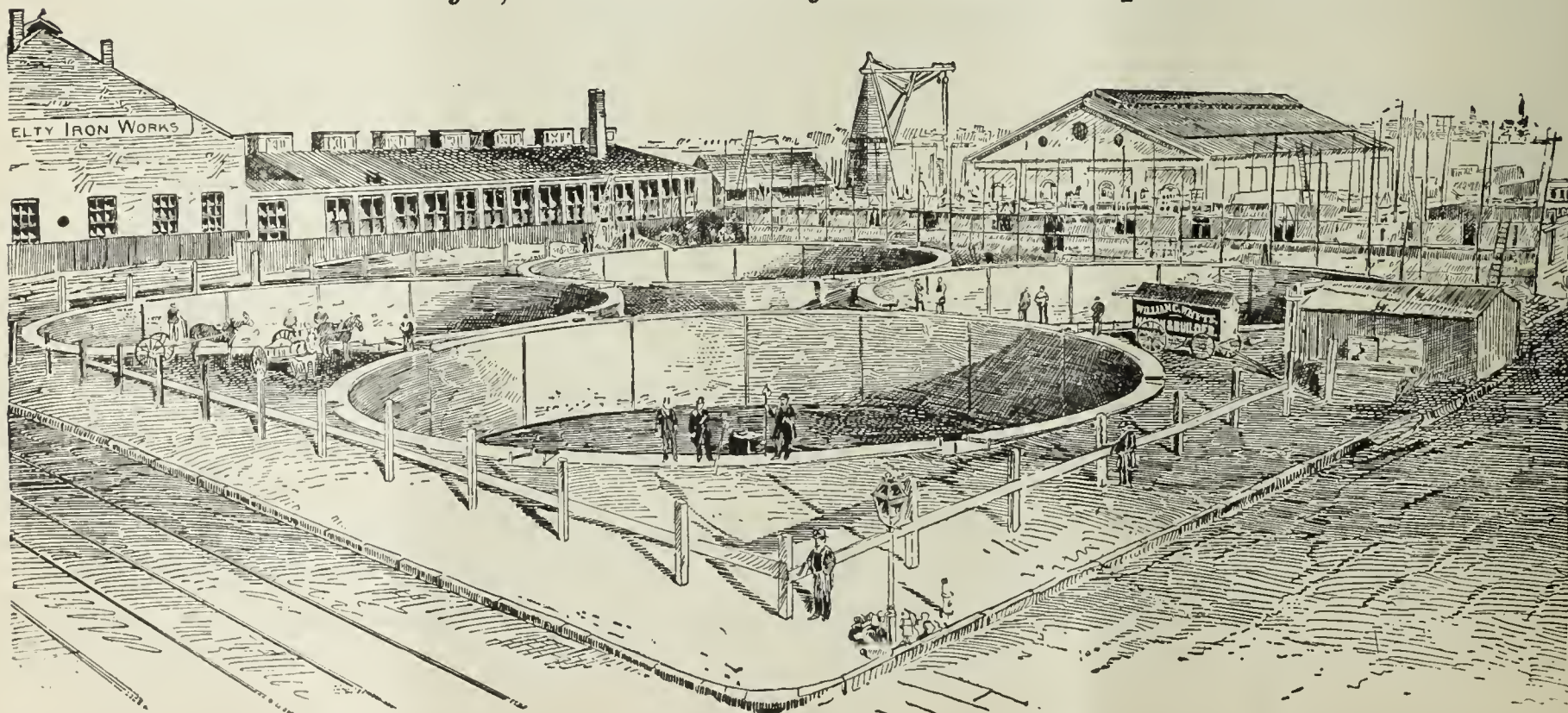

Tank Excavation and Mason Work.

Fifty Tanks now in operation show the sort of work done. Address

W. C. WHYTE, - No. 15 Cortlandt Street, N. Y. City.

CONNELLY & CO.,

SOLE MANUFACTURERS OF THEIR PATENTED SPECIALTIES.

"IRON SPONGE." Saves money, saves labor, and is the most efficient purifying agent ever offered as a substitute for lime. Now used in every State in the Union, and purifying daily over thirty-five million cubic feet. Should be used in every gas works. Its own saving will pay for it many times over.

AUTOMATIC GOVERNOR. Has been on the market but three years, and in that time has been introduced more generally than any invention ever designed for use in gas works. Over two hundred of them now in use. Sensitive; reliable; perfectly automatic; reduces leakage; satisfies consumers, and gives great relief to the Manager. No gas works is complete without one of these machines.

STEAM JET EXHAUSTER. Designed particularly for small works. Combines Exhaust Tube, Steam Governor Gas Compensator, and Bye-Pass Valves in the most compact form possible; occupies but little space; uses very little steam; operated by ordinary workmen; saves formation of carbon in retorts; increases yield 10 to 15 per cent. Specially adapted for mixing air with oil gas. No works too small to use them profitably.

Prices given on all our specialties delivered at any point in the United States. Correspondence solicited.

CONNELLY & CO., No. 111 Broadway, New York City.

WILBRAHAM GAS EXHAUSTER & ENGINE COMBINED.

WILBRAHAM BROS.,
PHILADELPHIA, PA.

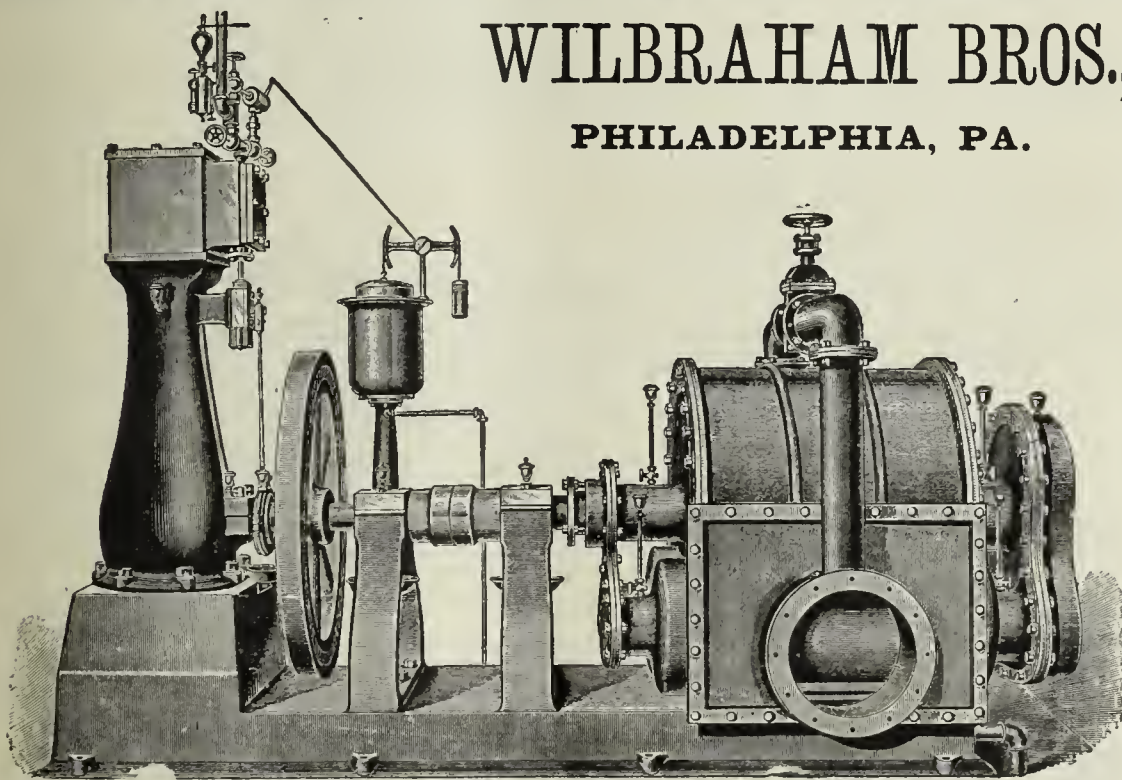

JARVIS ENGINEERING CO.,

61 Oliver St., Boston, Mass.

CONTRACTORS FOR ERECTING

COMPLETE STEAM OUTFITS FOR ELECTRIC LIGHTING STATIONS.

Steel Boilers set with Jarvis Pat. Boiler Setting

To burn **COKE SCREENINGS** for Fuel.

ARMINGTON & SIMS CO. ENGINES,

Belted direct to Dynamos, without using Shafting.

SEND FOR CIRCULARS.

REFERENCES.—Charlestown Gas & Electric Light Co., Charlestown, Mass.; Schenectady Gas & Electric Light Co., Schenectady N. Y.; Brookline Gas Co., Brookline, Mass.

Practical Electric Lighting

By A. BROMLEY HOLMES, A.M.I.C.E.

With 87 Illustrations. Third Edition. Price, \$1.00.

Electric Light Primer.

By CHARLES L. LEVEY.

A simple and comprehensive Digest of all the most important facts connected with the running of the Dynamo and Electric Lights, with Precautions for Safety, etc.

Price, 50 cents.

A. M. CALLENDER & CO., 42 Pine St., N. Y.

(Patented.)

IMPORTANT!

(Patented)

NEW SOLVENT FOR GAS PIPE DEPOSITS.

Economical and Effective.

MAAS & WALDSTEIN, 44 Trinity Place and 81 Greenwich St., N. Y.

Gasholder Tanks & Gas Works Masonry Complete.

PLANS PREPARED AND ESTIMATES FURNISHED AT SHORT NOTICE.

J. P. WHITTIER, - - 499 Wythe Av., Brooklyn, N. Y.



CHAPMAN VALVE MANUFACTURING CO.,

MANUFACTURERS OF

Valves and Gates for Gas, Ammonia, Water, Etc.

Also, Gate Fire Hydrants With and Without Independent Nozzle Valve. All Work Guaranteed.

WORKS & GEN'L OFFICE:
Indian Orchard, Mass.

TREASURER'S OFFICE:
72 Kilby & 112 Milk Sts, Boston, Mass.

LUDLOW VALVE MFG. CO.



OFFICE AND WORKS,

938 to 954 River Street and 67 to 83 Vall Av.,
TROY, N. Y.

GEO. SHEPARD PAGE,

No. 69 Wall Street, N. Y. City.

REPRESENTING

THE BOWER GAS LAMP.

C. & W. Walker's Carbonic Acid & Tar Extracting Washer

B. DONKIN & CO.'S PAT. IMP. GAS VALVE.

Young & Beilby's Patents. Henry Aitkin's Patents.

R. P. SPICE, London, Eng. HENRY SIMON, Manchester, Eng.

MILLS' REVERSIBLE LIME TRAY,

AND

WOODWORK

Of Every Description

NEEDED BY GAS WORKS.

SEND FOR CIRCULAR AND PRICE LIST TO

BARTLETT, HAYWARD & CO.,

Pratt and Scott Streets, Baltimore, Md.

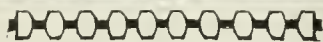
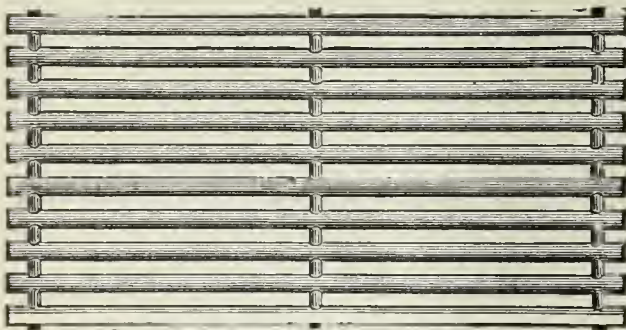

VAN DUZEN GAS & GASOLINE ENGINE

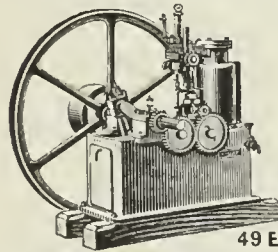

OPERATED with COAL and OTHER MANUFACTURED GASES AND GASOLINE.

RELIABLE AND ECONOMICAL.

Fully Warranted

VAN DUZEN Gas & Gasoline Engine Co. 49 E. 2d St., Cincinnati, O.

A. MacKinnon Machine Co., Agts., 22 Warren St., N.Y.

The Management of Small Gas Works.

BY C. J. R. HUMPHREYS.

Price, \$1.

Orders to be sent to **A. M. CALLENDER & CO.,**

42 PINE STREET, NEW YORK.

Hydraulic Main Dip Regulators, also Check Valves, Foot Valves, Yard-wash and Fire Hydrants. Send for Circulars.



Valves.—Double and Single Gate, 1/2 in. to 48 in., outside and inside Screws. Indicator, etc., for Gas, Water, Steam, and Oil. Send for Circulars.

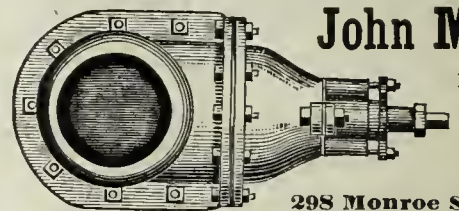

John McLean

Manufacturer

GAS VALVES.

298 Monroe Street, N. Y.

CHURCH'S TRAYS A SPECIALTY.

REVERSIBLE-STRONGEST-MOST DURABLE-MOST EASILY REPAIRED.

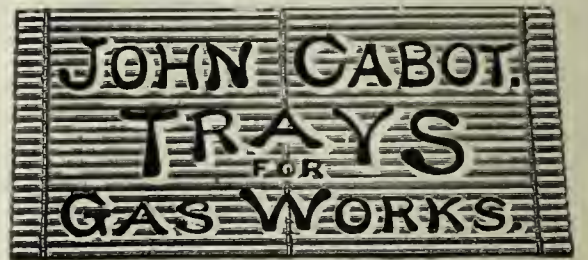

306-310 ELEVENTH AVENUE, NEW YORK.

WE ALSO MAKE THE CHEAPEST AND STRONGEST REVERSIBLE BOLTED TRAYS IN THE MARKET.

THE CLERK GAS ENGINE CO.,

Main Office, 1012, 1014, 1016, 1018 Filbert St., Philadelphia, Pa.

WM. W. GOODWIN, Prest.

E. STEIN, Sec.

S. LEWIS JONES, Asst. Sec.

A. J. DOTY, Supt.

The utility and convenience of the Gas Engine being no longer an open question, it only remains now for intending purchasers to select the BEST. We claim for the CLERK GAS ENGINE that it is equal to any other manufactured as regards steadiness in running, simplicity, and ease of keeping in repair, and that it gives the greatest amount of power for the least money (both in first cost and expense of running) of any engine made. In support of this claim we refer to the test of the Gas Engines made under the direction of the American Institute of New York, in December, 1885, and heretofore published in these columns. These engines are especially adapted for continuous running under heavy loads, and we can refer to Engines which have run 22 hours a day for months at a time

Made in Sizes of 5 10 15 20, and 25 Horse Power. All Engines Guaranteed for One Year.

GAS STOVES.

GAS METERS.

GAS STOVES.

THE AMERICAN METER CO.,

MANUFACTURERS OF

GAS METERS, Station Meters,

METER PROVERS, PHOTOMETERS,
PRESSURE GAUGES OF ALL KINDS.



Standard 3 Diaphragm Dry Meter

AND

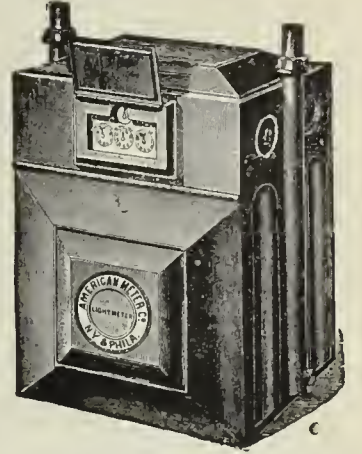

Standard 2 Diaphragm Dry Meter.

Apparatus for Testing the Quantity and Quality of Gases.

GAS STOVES FOR HEATING AND COOKING

Sole Agents in the United States for

Verity's Patent Gas Fires.

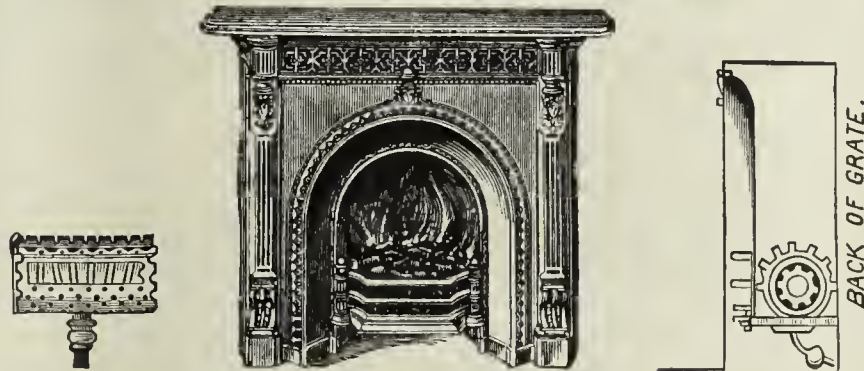

Circulars and Price Lists on Application.

MANUFACTORIES,

508 to 514 West Twenty-second St., N. Y.

Arch and Twenty-second St., Phila.

Nos. 244 & 246 North Wells Street, Chicago, Ill.

AGENCIES,

No. 177 Elm Street, Cincinnati, Ohio.

No. 222 Sutter Street, San Francisco, Cal.

No. 810 North Second Street, St. Louis, Mo.

GAS STOVE SHOW ROOMS, No. 242 Sixth Avenue, New York City.

RETORTS AND FIRE BRICK.

RETORTS AND FIRE BRICK.

RETORTS AND FIRE BRICK.

J. H. GAUTIER & CO.,

CORNER OF GREENE AND ESSEX STREETS, JERSEY CITY, N. J.

MANUFACTURERS OF

Clay Gas Retorts, Gas House Tiles, Fire Bricks, Etc. Etc.

Ground Clay, Fire Brick and Fire Sand in Barrels,

J. H. GAUTIER. C. E. GREGORY. C. E. GAUTIER.

BROOKLYN Clay Retort & Fire Brick Works, (EDWARD D. WHITE & CO.)

Manufacturers of Clay Retorts, Fire Brick, Gas House and other Tile. VAN DYKE, ELIZABETH, RICHARDS & PARTITION STS. Office, 88 Van Dyke St., Brooklyn, N. Y.

LACLEDE FIRE BRICK MFG. CO.,

MANUFACTURERS OF

Fire Brick, Gas Retorts,

AND

ST. LOUIS STANDARD SEWER PIPE.

Blast Furnace and Cupola Linings, every description of Fire Clay Material, Fire Clay Flue Linings, Chimney Tops Dry Milled and Crude Fire Clays, etc.

OFFICE AND DEPOT

901, 903, and 905 Pine Street, ST. LOUIS, MO.

ESTABLISHED IN 1845.

B. KREISCHER & SONS,

OFFICE FOOT OF HOUSTON ST., E.R., N.Y.

Gas Retorts,

TILES, FIRE BRICK.

AND EVERYTHING IN THE FIRE CLAY LINE.

MANHATTAN FIRE BRICK & ENAMELLED CLAY RETORT WORKS ADAM WEBER.

CLAY GAS RETORTS AND RETORT SETTINGS FIRE BRICKS, TILES, ETC.,

Office and Works, 15th Street and Avenue C., N. Y.



Works, LOCKPORT STATION, PA.

ESTABLISHED 1864.

JAMES GARDNER, JR.,

Successor to WILLIAM GARDNER & SON.

Fire Clay Goods for Gas Works.

H. A. NORTON, No. 4 CENTRAL STREET, BOSTON, MASS., Agent for the New England States.

Office, Rooms 19 & 20, Lewis Block, PITTSBURGH, PA, P. O. Box 373.

GEO. C. HICKS, Prest. CHICAGO CHAS. A. REED, Sec. & Treas.

Retort and Fire Brick Co.,

MANUFACTURERS OF

Fire Clay Goods of all Kinds,

AND BEST QUALITY ONLY.

Regenerative Furnaces & Water Gas Goods.

45th St., Clark to La Salle, Chicago.

GEROULD'S IMPROVED RETORT CEMENT.

A Cement for patching retorts, putting on mouthpieces, and making up all bench-work joints. This Cement is mixed ready or use. Economic and thorough in its work. Fully warranted o stick. For recommendations and price list address

C. L. GEROULD & CO.,

5 & 7 Skillman St., Brooklyn, N. Y.

Western Agent, H. T. GEROULD, Mendota, Ill.

Parker-Russell Mining and Mfg. Co.,

CITY OFFICE: Mermod-Jaccard Bldg., Rooms 307 & 308, Broadway and Locust Street, St. Louis, Mo.

PROPRIETORS OF THE

OAKHILL GAS RETORT & FIRE BRICK W'KS

Our immense establishment is now employed almost entirely in the manufacture of materials for

GAS COMPANIES.

We have studied and perfected three important points. Our retorts are made to stand changes of temperature, the strongest heats of the furnace, and the abrasion of feeding and emptying.

We furnish and build Half-Depth or Full REGENERATOR FURNACES of different kinds and most approved styles.

Correspondence solicited.

THOS. SMITH, Prest. AUGUST LAMBLA, Vice-Prest. & Supt.

BALTIMORE

RETORT & FIRE BRICK CO.

MANUFACTORY AT

LOCUST POINT, BALTIMORE, MD.

Clay Retorts, Blocks & Tiles, FIRE BRICK, FIRE CLAY, AND FIRE CEMENT.

Red and Buff Ornamental Tiles and Chimney Tops. Drain and Sewer Pipe (from 2 to 30 inches). Baker Oven Tiles 12x12x2 and 10x10x2.

WALDO BROS., 88 WATER ST., BOSTON, MASS.

Sole Agents the New England States.

1889 DIRECTORY 1889

OF THE GAS LIGHT COMPANIES of the UNITED STATES & CANADA.

Price, \$8.00.

A. M. CALLENDER & CO., No. 42 Pine Street, N. Y. City.

HENRY MAURER & SON,

(ESTABLISHED 1856.)

**EXCELSIOR FIRE BRICK & CLAY
RETORT WORKS**

WORKS, Perth Amboy, N. J.
OFFICE, 418 to 422 East 23d St., N. Y.

**Clay Gas Retorts,
BENCH SETTINGS,
Fire Brick, Tiles, Etc.**

FLEMMING'S

Generator-Gas Furnace

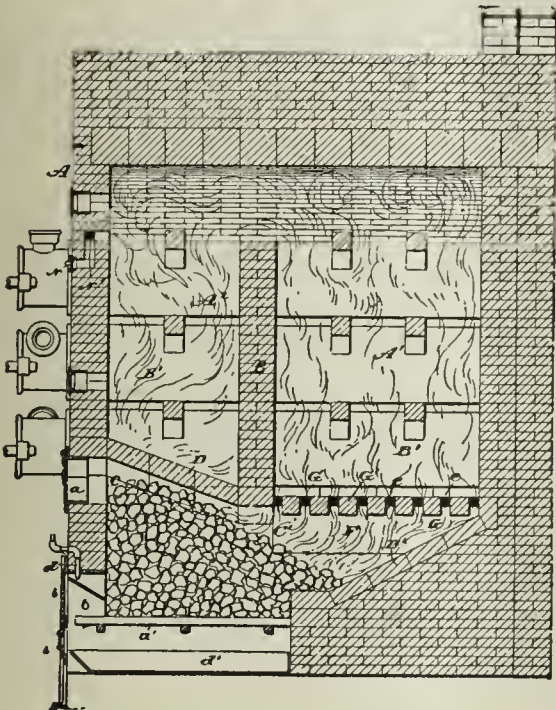

Materials furnished and Benches erected by

J. H. GAUTIER & CO., - Jersey City, N. J.

Address as above, or D. D. FLEMMING, Jersey City, N. J.

FRED. BREDEL,

CONTRACTOR FOR THE COMPLETE

Erection and Equipment of Gas Works.

SOLE PROPRIETOR OF THE

KLOENNE PATENTS

FOR NORTH AMERICA.

REGENERATIVE FURNACES.

(900 Retorts are now fired in America by the Kloenne-Bredel System.)

SELF-SEALING MOUTHPIECES.

(Over 800 Now in Use.)

Standard Condensers. Washer-Scrubbers.

TAR WASHERS FOR WATER GAS PLANTS.

(In use in the works of the Chicago Gas Lt. Co.)

GASHOLDERS.

Bredel's Automatic Gas Governor.

Refers, by permission, to Mr. Eugene Vanderpool, Newark, N. J.; Mr E. G. Cowdery, Milwaukee, Wis.; and Mr. Theo. Forstall, Chicago, Ills. For further infomation, address

FRED. BREDEL,

No. 208 East Seventeenth Street, N. Y. City.

HENRY PRATT & CO.,

BUILDERS OF THE

PRATT & RYAN WATER GAS GENERATORS,

Arranged to Use Either Crude Oil or Naphtha.

Condensers, Scrubbers, Purifiers, and all Apparatus for Coal or Water Gas.

IRON ROOFS, BOILERS, TANKS, ETC.

Orders and Correspondence Solicited.

Plans and Estimates Furnished for New Works or for the Alteration of Old Works.

Office and Works, 869 to 875 So. Halsted St. CHICAGO, ILL.

COMPOUND Condensing or Non-Condensing.

16 SIZES, 5 to 500 H. P.

Not yet equaled by any form of Engine for **HIGH FUEL DUTY AND SIMPLICITY.**

STANDARD 13 Sizes in Stock. 5 to 250 H. P.

3000 in use in all parts of the Civilized World.

JUNIOR 6 Sizes in Stock, 5 to 50 H. P.

An Automatic Engine cheaper than a Slide Valve. WELL BUILT. ECONOMICAL. RELIABLE.

Over 300 Sold the First Year.

All the above built strictly to Gauge with INTERCHANGEABLE PARTS.

REPAIRS CARRIED IN STOCK.

SEND FOR ILLUSTRATED CATALOGUES.

WESTINGHOUSE ENGINES
The Westinghouse Machine Co.
PITTSBURGH, PA. U.S.A.

SELLING DEPARTMENT IN THE UNITED STATES.

- | | | |
|---------------------|--|---|
| New York, | 17 Cortlandt St. | } Westinghouse, Church, Kerr & Co. |
| Boston, | Hathaway Building, | |
| Pittsburgh, | Westinghouse Build'g, | |
| Chicago, | 156, 158 Lake St. | |
| Philadelphia, | 608 Chestnut St. M. R. Muekle, Jr. & Co. | |
| St. Louis, | 302, 304 Washington Av. | } Fairbanks & Co. |
| Kansas City, | 312 Union Avenue, | |
| Denver, | 1330 Seventeenth St. | |
| Omaha, | 1619 Capitol Avenue, F. C. Ayer. | |
| Pine Bluffs, Ark. | | Geo. M. Dilley & Sons. |
| Salt Lake City, | 256 S. Main St. | } Utah & Montana |
| Butte, Mont. | 2 Granite St. | |
| | | Machinery Co. |
| San Francisco, | 21, 23 Fremont Street, | Parke & Lacy Co. |
| Portland, Or. | 33, 35 N. Front St. | Parke & Lacy Meh. Co. |
| Charlotte, N. C. | 36 College St. | } The D & Tompkins Co. |
| Atlanta, Ga. | 45 S. Prior St. | |
| Dallas, Tex. | | Keating Imp. & Machine Co.
C. E. James & Co. |
| Chattanooga, Tenn., | | |

GAS AND WATER PIPES.

GAS AND WATER PIPES.

ENGINEERS.

SAM'L R. SHIPLEY, Pres.
HENRY B. CHEW, Tre

JAS. P. MICHELLON, Sec.
WM. SEXTON, Supt.

P. D. WANNER, Chairman. A. H. MELLERT, Mangr. of Wks.
R. B. KINSEY, Secretary. F. A. KNOPP, Treasurer.

GLOUCESTER IRON WORKS,
GLOUCESTER CITY, N. J.



Cast Iron Gas & Water Pipes, Stop Valves, Fire Hydrants, Gasholders. &c.

Office, Rooms 61 and 63 Bullitt Building, 131 S. 4th St., Phila., Pa.

WARREN FOUNDRY AND MACHINE CO.,

Established 1856. Works at Phillipsburgh, N. J.

New York Office, 160 Broadway.

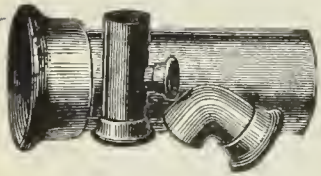

CAST IRON WATER AND GAS PIPE,

FROM TWO TO FORTY-EIGHT INCHES DIAMETER. ALSO, ALL SIZES OF

Flange Pipe for Sugar House and Mine Work. Branches, Bends, Retorts, etc., etc.

DENNIS LONG & COMPANY,

LOUISVILLE, KY.,



Manufacture Exclusively

CAST IRON GAS & WATER PIPE & SPECIAL CASTINGS
OF ALL SIZES.

King's Treatise on Coal Gas.

A standard text-book for the Engineers and Managers of Gas Works, and for all who are concerned or take an interest in the manufacture and distribution of Coal Gas, and in the utilization of the Secondary Products resulting therefrom; treating also of the Gas Engine, and of Gas Cooking and Heating Appliances.

In 3 Vols. Price per Vol., \$10. Sold either by Volume or in Sets.

A. M. CALLENDER & CO., 42 Pine St., N. Y.

MELLERT FOUNDRY & MACHINE CO. Ltd.
and **READING FOUNDRY CO., Ltd.**
Reading, Pa.



Specials—Flange Pipe, Valves and Hydrants
Lamp Posts, Retorts, etc.
General Foundry and Machine Work.
JOHN FOX, Selling Agent. 160 Broadway, N. Y.

THE OHIO PIPE COMPANY,

MANUFACTURERS OF

Cast Iron Gas & Water Pipe,

BRANCH AND SPECIAL CASTINGS.

Gas-House Bench Castings, Hydraulics, Lamp Posts, Flange Pipe
and Specials, Architectural Castings, Building Columns,
Joists, Cellar Grates, Sash Weights, etc.

GENERAL FOUNDERS AND MACHINISTS.

Columbus, Ohio.

M. J. DRUMMOND,



SPECIAL CASTINGS AND LAMP POSTS.
Office, Corbin Building, 192 Broadway, N. Y.

EMAUS PIPE FOUNDRY.

DONALDSON IRON COMPANY. EMAUS, PA.



MANUFACTURERS OF

CAST IRON PIPE AND SPECIAL CASTINGS
FOR WATER AND GAS.

JOS. R. THOMAS,

No. 42 Pine Street, N. Y. City.

CONSULTING AND CONSTRUCTING

Gas Engineer and Contractor.

PLANS, SPECIFICATIONS, AND ESTIMATES
FURNISHED.

Contracts taken for all Appliances
required at a Gas Works,
Either for New Works or Extensions to Old Plants.

WM. MOONEY

(Successor to WM. FARMER)

No. 94 Liberty St., N. Y. City.

GAS ENGINEER AND CONTRACTOR FOR THE ERECTION
OF GAS WORKS, OR APPARATUS OF ANY
CAPACITY.

Plans and Specifications Furnished.

WM. GARDNER,
Gas Engineer,

Lewis Block, Room 20, Pittsburgh, Pa.

Those who intend to make alterations in existing gas plants, or who contemplate the erection of new works, will find it to their interest to open correspondence with the above. Plans and estimates furnished.

BARTLETT, HAYWARD & CO.

Baltimore, Md.

Triple Double, & Single-Lift
GASHOLDERS.

Iron Holder Tanks.

ROOF FRAMES.

Cirders.

BEAMS.

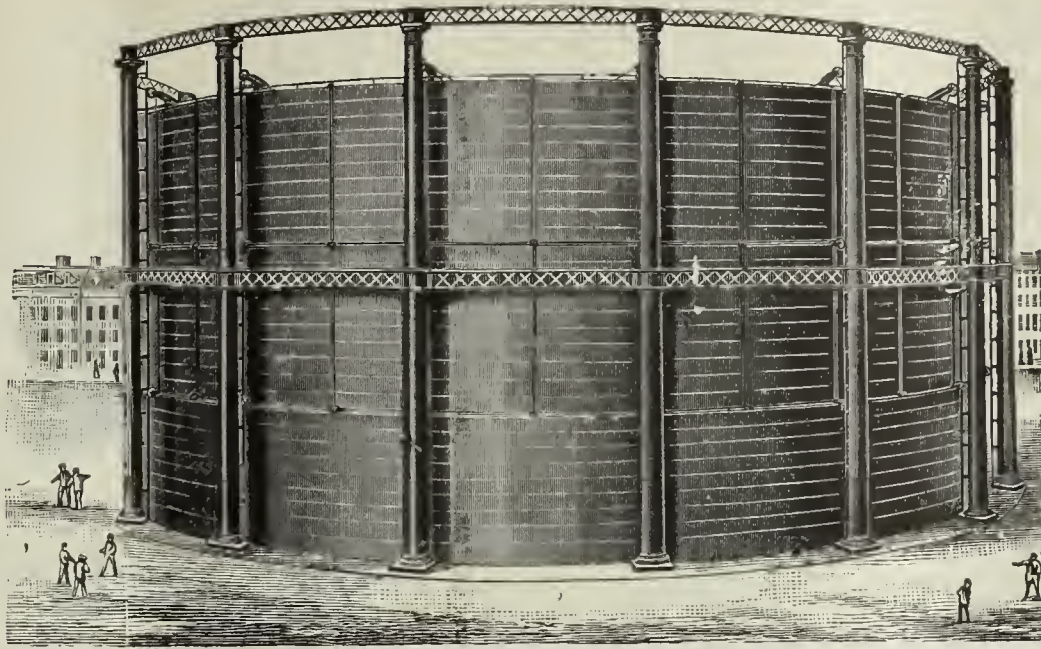

PURIFIERS.

CONDENSERS.

Scrubbers.

BENCH CASTINGS.

OIL STORAGE TANKS.

Boilers.

The Wilkinson Water Gas Process.

THIRTY-CANDLE, NON-CONDENSABLE, FIXED GAS. THE MOST SUCCESSFUL GAS PROCESS IN OPERATION.

Munich Regenerative Furnace, System Drs. Schilling & Bunte.

HAZELTON BOILERS.

Gas Works Designed and Constructed.

Pascal Iron Works. ESTABLISHED 1821. Delaware Iron Works.

MORRIS, TASKER & CO.,

INCORPORATED.

OFFICE, 224 SOUTH THIRD STREET, - - PHILADELPHIA, PA.

CONTRACTORS, BUILDERS, AND MANUFACTURERS OF

Gas, Water & Sugar Works

Bench Castings.

Condensers.

Scrubbers.

Purifiers.

Hyd. Carriages.

Iron Floors,

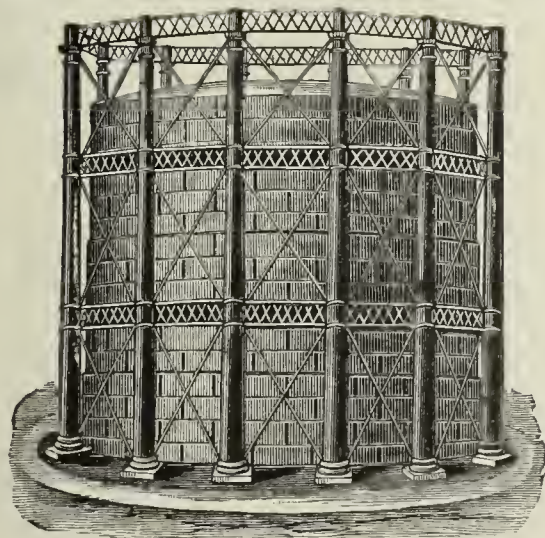

Iron Roofs.

Street Stops,

Valves, etc.

Stand-Pipes.

Water & Oil

Tanks, all Sizes.

Single, Double, and Triple-Lift Gas Holders.

SELF-SEALING RETORT LIDS. STAMPED STEEL RETORT LIDS.

Locomotive Water Columns, Filters, etc. Boiler Tubes, Wrought Iron Pipe & Fittings

Plans, Specifications and Estimates for all kinds of Machinery furnished on application.

Foundries & Works,
MILLVILLE, FLORENCE,
and CAMDEN, N. J.

R. D. WOOD & CO.,

Engineers,
Iron Founders,
and
Machinists.

400 Chestnut St., PHILADELPHIA, PA.

MANUFACTURERS OF

CAST IRON PIPE,

Gas Holders,

SINGLE, DOUBLE, AND TRIPLE LIFTS, WITH
OR WITHOUT WROUGHT IRON
OR STEEL TANKS.

PURIFIERS, CONDENSERS.

Scrubbers.

BENCH WORK.

Iron Floors and Roofs, Plate Girders.

Heavy Loam Castings.

HYDRAULIC WORK.

Lamp Posts, Valves, Etc.

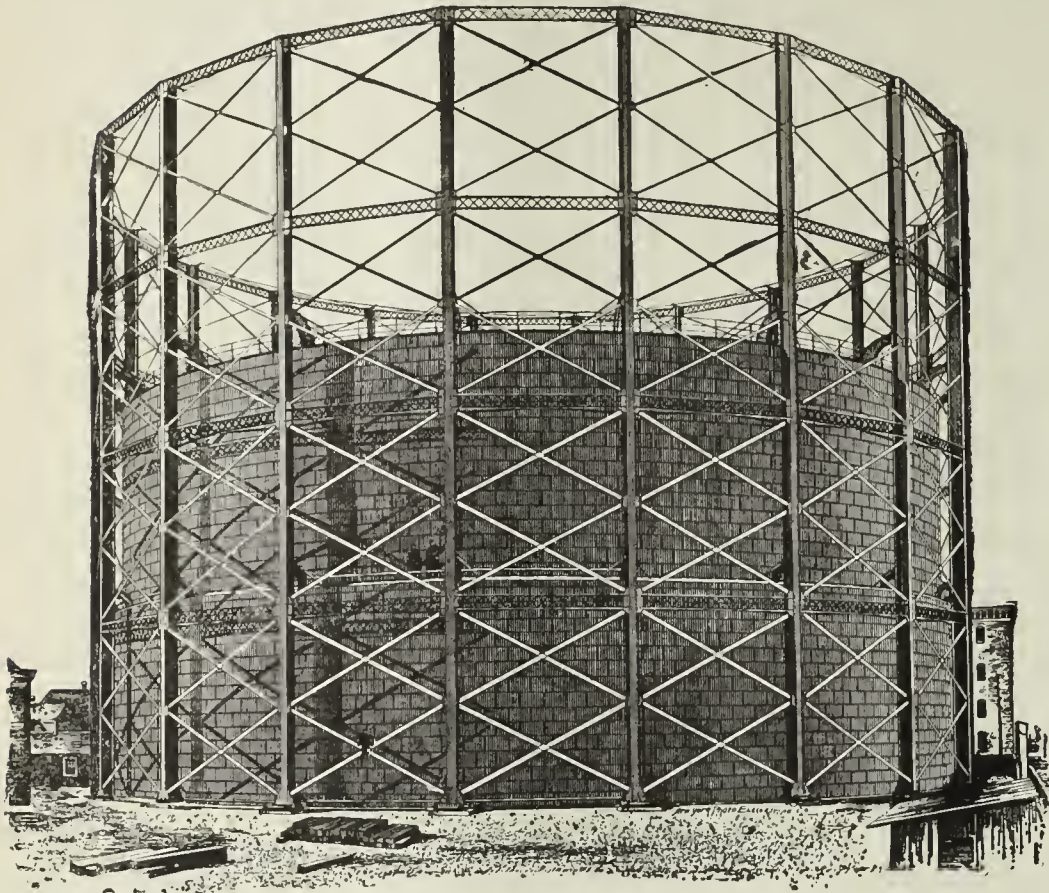

SMITH & SAYRE MFG. COMPANY,

G. G. PORTER, Prest.

245 Broadway, N. Y.

CHAS. W. ISBELL, Sec'y.

Machinery & Apparatus for Gas Works

Drawings, Plans, and Estimates Furnished for the Improvement, Extension, or Alteration of Gas Works, or for the Construction of New Works.

Mackenzie's Patent Rotary and Steam Jet Gas Exhausters, Governors, Compensators, Condensers, Washers, Scrubbers. Isbell's Patent Automatic Street Pressure Governor, Gas and Water Valves, Hydraulic Main Dip Regulator, Bench Castings, etc. Purifying Boxes and "Standard" Scrubbers, Isbell's Patent Self-Sealing Retort Doors.

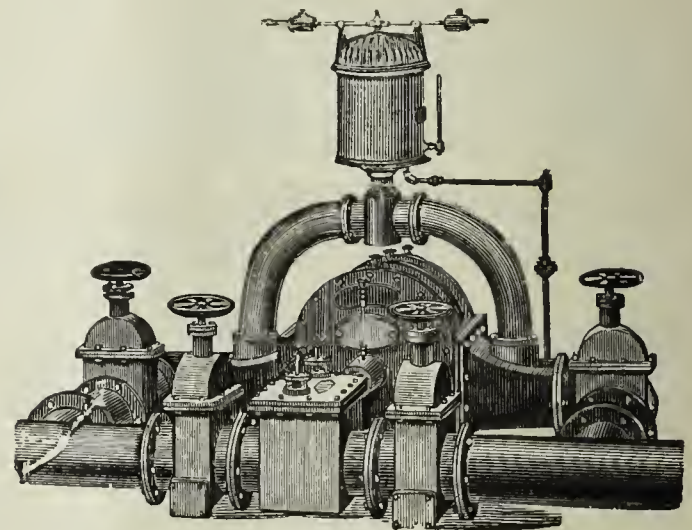

THE BRENNER SELF-SEALING RETORT DOOR.

Simple, Strong, and Durable.

CLOSES ABSOLUTELY TIGHT & IS LOCKED BY A CAM LEVER. ALL NECESSARY ADJUSTMENT FOR WEAR PROVIDED.

BUILT BY

SMITH & SAYRE MFG. CO.,

No. 245 Broadway, - - - - New York City.

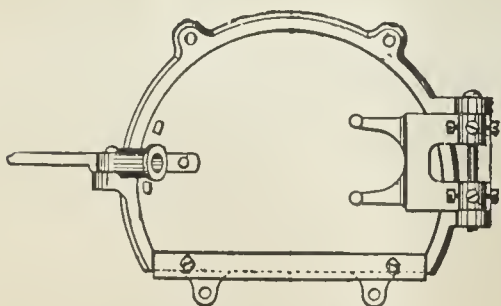

Brenner Self-Sealing Retort Door.

WILLIAM B. LUNDIE, Superintendent of the 42d Street Station of the Consolidated Gas Company, of New York, writes, under date of Jan. 4, 1889:

"We have 320 Brenner Self-Sealing Lids in use at this Station, built by the Smith & Sayre Mfg. Co. They require very little attention, and are the best of the kind that I have seen, giving entire satisfaction."

GAS WORKS APPARATUS AND CONSTRUCTION.

GAS WORKS APPARATUS AND CONSTRUCTION.

JAMES R. FLOYD & SONS,

(SUCCESSORS TO HERRING & FLOYD)

Oregon Iron Works,

W. 20th & 21st. Sts., bet. 10th & 11th Aves.,
NEW YORK CITY.

Engineers and Contractors

FOR THE

CONSTRUCTION OF GAS WORKS.

MANUFACTURERS OF

All Kinds of Castings and General Ironwork

FOR

GAS APPARATUS.

Bench Castings, Regenerative and Half Regenerative Furnace Castings.

Condensers, Scrubbers, Purifiers, Street Drips and Connections,

Valves,

Hydraulic Hoisting Purifier Carriage, Self-Sealing Retort Lids, Improved Valve Stand and Indicator,

Seller's Cement.

Plans, Specifications, and Estimates furnished for Construction of New or Alteration of Old Works.

CONTINENTAL IRON WORKS.

THOS. F. ROWLAND, Prest.

WARREN E. HILL and CHAS. H. CORBETT, V-Prests.

THOS. F. ROWLAND, JR., Sec. & Tr

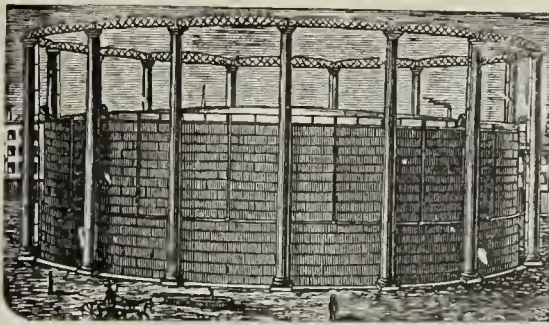

P. O. Station G., BROOKLYN, N. Y.

ENGINEERS AND MANUFACTURERS OF

Gas Holders

CONDENSERS, SCRUBBERS, VALVES,

PURIFIERS, SELF-SEALING RETORT LIDS

Hydraulic Mains,

And all other articles connected with the manufacture and distribution of Gas.

H. RANSHAW, Prest. & Mangr.

WM. STACEY, Vice-Prest.

T. H. BIRCH, Asst. Mangr.

R. J. TARVIN, Sec. & Treas.

STACEY MFG. CO.,

MANUFACTURERS OF

Single and Telescopic Gasholders,

IRON ROOFS, BRIDGES, LAMP POSTS,

Water and Oil Tanks, Coal Elevator Cars,

COKE CRUSHERS, BENCH CASTINGS,

And all kinds of Wrought and Cast Iron Work used in the erection of Coal and Oil Gas Works Rolling Mill Machinery and Heavy Castings a Specialty.

Foundry:

33, 35, 37 & 39 Mill Street.

Wrought Iron Works:

16, 18, 20, 22, 24 & 26 Ramsey Street:

Cincinnati, Ohio.

Bouton Foundry Co.,

FOUNDERS AND MACHINISTS,

CHICAGO, ILL.

Gas Works Apparatus,

PURIFIERS, CONDENSERS,

Bench Work

SPECIALS, LAMP POSTS,

SCRUBBERS,

Iron Roofs and Floors.

Plans and Estimates furnished for new works or extensions of old works.

1842. **DEILY & FOWLER,** 1889.

Laurel Iron Works.

Address, No. 39 Laurel Street, Philadelphia, Pa.

BUILDERS OF

GASHOLDERS,

Single and Telescopic.

HOLDERS Built 1884 to 1888, Inclusive:

- | | | | | |
|----------------------------|-----------------------------|--------------------------|--------------------------|------------------------|
| Newport, R. I. | Long Island City, N. Y. | Port Chester, N. Y. | Malden, Mass. | West Chester, Pa. (2d) |
| Portland, Oregon. | Macon, Ga. | New Rochelle, N. Y. | Paducah, Ky. | Lancaster, Pa. (3d) |
| Allegheny, Pa. (2d.) | York, Pa. | Salem, N. J. (3d) | Norwich, Conn. | Facony, Pa. (two) |
| Atlanta, Ga. (2d.) | Chester, Pa. | Omaha, Neb. (2d) | Seattle, W. T. | Mount Vernon, N. Y. |
| N.Y. City (Central Gas Co) | Hazleton, Pa. (2d.) | Lynn, Mass. (2d) | San Diego, Cal. | Binghamton, N. Y. |
| Lynchburg, Va. (2d.) | State Island, N. Y. | Little Rock, Ark. | Northern Gas Lt. Co., of | Concord, N. H. |
| Saylesville, R. I. | Saugerties, N. Y. | Irrington, N. Y. | New York, N. Y. | Dover, Del. (2d) |
| Rondout, N. Y. | Clinton, Mass. (Lan. Mills) | South Boston, Mass. | Westerly, R. I. | Calais, Me. |
| Atlantic City, N. J. | Chattanooga, Tenn. | Rye, N. Y. (2) | Willimantic, Conn | New London, Conn. (2d) |
| Augusta, Ga. | Galveston, Texas. (3d.) | Woodstock, Ont. | Montclair, N. J. | West Chester, N. Y. |
| Waltham, Mass. (2) | Omaha, Neb. | Malden, Mass. | Attleboro, Mass. | Bay Shore, L. I. |
| Mahanoy City, Pa. | Fort Plain, N. Y. | State Island, N. Y. (2d) | Santa Cruz, Cal. | Washington, D. C. |
| New Castle, Pa. | Brunswick, Ga. | Woodstock, Ont. | Erie, Pa. (2d) | |

WM. HENRY WHITE,

No. 32 Pine Street, - - - New York City.

ENGINEER AND CONTRACTOR FOR THE

Erection and Extension of Gas, Water, and Electric Light Works.

SOLE REPRESENTATIVE OF THE

McILHENNY REGENERATOR FURNACE PATENTS

And the Martin Water Gas Process.

Edison Incandescent and American Arc Electric Light Plants Installed.

Correspondence with Gas Companies contemplating extending or improving their Plants respectfully invited. Plans and Estimates Furnished.

GAS COALS.

CANNEL COALS.

GAS ENRICHERS.

JAMES D. PERKINS. **PERKINS & CO.,** F. SEAVERNS.
228 & 229 Produce Exchange, New York.

Cable Address, "PERKINS, NEW YORK."

Post Office Box 3695, New York.

GENERAL SALES AGENTS FOR

The Youghiogeny River Coal Company's

OCEAN MINE YOUGHIOGHENY GAS COAL.

HON. W. L. SCOTT, Prest.

M. H. TAYLOR, Vice-Prest.

This Colliery is located at SCOTT HAVEN, PA., in the center of the Youghiogeny Gas Coal District, and produces the ONLY RELIABLE YOUGHIOGHENY COAL for gas purposes. (See Map on p. 87 of this JOURNAL, Feb. 16, '85.)

POINTS OF SHIPMENT,

Locust Point, BALTIMORE.

Pier No. 62, PHILADELPHIA.

Also, SOLE AGENTS for the

**BRECKENRIDGE CANNEL,
OF KENTUCKY.**

Within the past two years we have delivered this Cannel to over ONE HUNDRED COMPANIES IN THIRTY-THREE DIFFERENT STATES, and it is now in use in some of the large Gas Works

On the Continent and in South America,

where it successfully competes with the Australian Shale. It is the ONLY AMERICAN GAS CANNEL of sufficiently high grade to warrant EXPORTATION TO EUROPE AND SOUTH AMERICA, and it is the only economical substitute for OIL OR NAPHTHA. ONE GROSS TON will produce

10,000 Cubic Feet of 75 Candle Gas,	} equal to {	750,000 Candle Feet of Gas, and 26 Bushels of merchantable Coke weighing 900 Pounds
or 12,500 " " 60 " "		
or 15,000 " " 50 " "		

This is the ONLY GAS CANNEL that will produce a REALLY MERCHANTABLE COKE. It can be delivered in parcels of one carload or more to any point in the United States or Canada. Cargo shipments of any size required can be made from NEW YORK, PHILADELPHIA, BALTIMORE, or NEWPORT NEWS. Samples will be sent and particulars of price, etc., forwarded upon application to above address.

JAMES & WILLIAM WOOD,
Gas and Cannel Coal Contractors,

No. 40 St. Enoch Sq., Glasgow. No. 2 Talbot Court, London.

Proprietors of the BATHVILLE COLLIERIES (which produce the celebrated BOGHEAD CANNEL), Shields, Shieldmuir, Drumpeller, and other Collieries. This Firm offer

STANDARD CANNELS,

Unequaled as Gas Enrichers.

Also, WEST FAIRMONT GAS COAL, of W. Va.

Analyses, prices, and all further information furnished on application to

Agency for U. S., Room 93, Nos. 2 & 4 Stone St., N.Y. City.

The Standard Oil Company,

REFINERS OF

NAPHTHA AND GASOLINES.

ALSO MANUFACTURERS OF

A Special Grade of Naptha for Gas Companies

FOR ENRICHING COAL GAS.

Correspondence solicited.

No. 43 Euclid Avenue, Cleveland, Ohio.

To Gas Companies.

We make to order CAP BURNERS to burn any amount under a stated pressure. Send for samples.

Also, SERVICE CLEANERS, DRIP PUMPS, and STREET MAIN PROVING APPARATUS.

C. A. GEFROER,

248 N 8th Street, Phila., Pa.

COKE CRUSHERS.

GAS COALS.

GAS COALS.

Newburgh Orrel Coal and Coke Co.

MINERS AND SHIPPERS OF

STEAM, SMITHING, AND GAS COALS,
Foundry and Crushed Coke.

Home Office, 33 S. Gay Street, Baltimore, Md.

J. HARRY LEE, President.

Shipping Wharves, Locust Point, Baltimore.

The Despard Gas Coal Co.,

MINERS AND SHIPPERS OF

DESPARD GAS COAL,

AND MANUFACTURERS OF

COKE.

MINES, Clarksburg, Harrison Co., W. Va.

WHARVES, Locust Point, Baltimore, Md.

OFFICE, 225 E. German St., " "

ROUSSEL & HICKS, } AGENTS. } BANGS & HORTON,
71 Broadway, N. Y. } 60 Congress St., Boston.

THE
PENN GAS COAL CO.

OFFER THEIR

Coal, Carefully Screened & Prepared for Gas Purposes.

Their Property is located in the Youghiogeny Coal Basin, near Irwin and Penn Stations on the Pennsylvania Railroad, and on the Youghiogeny River.

Principal Office:

209 SOUTH THIRD STREET, PHILA., PA.

Points of Shipment:

Pennsylvania Railroad Piers; Greenwich Wharves, Delaware River; Pier No. 1 (Lower Side), South Amboy, N. J.

Chesapeake & Ohio Railway Coal Agency,

FOR THE SALE OF THE

Superior Kanawha Gas Coals, Cannelton Cannel,
Also, SPLINT AND STEAM COALS,

From the Kanawha and New River Regions, on the line of the Chesapeake & Ohio R'way.

C. B. ORCUTT, General Agent, - - No. 1 Broadway (Room 217) New York City.

FRANCIS H. JACKSON, Prest. EDMUND H. MCCULLOUGH, V.-Prest. CHAS. F. GODSHALL, Treas. H. C. ADAMS, Sec.

THE WESTMORELAND COAL CO.

Chartered 1854.

Mines situated on the Pennsylvania and the Baltimore and Ohio Railroads, in Westmoreland County, Penn.

POINTS OF SHIPMENT:

PHILADELPHIA, BALTIMORE, SOUTH AMBOY, N. J.,
WATKINS (SENECA LAKE), N. Y.

Since the commencement of operations by this Company its well-known Coal has been largely used by the Gas Companies of New England and the Middle States, and its character is established as having no superior in gas-giving qualities, and in freedom from sulphur and other impurities.

Principal Office, 224 South 3d St., Phila., Pa.

The American Gas Engineer and Superintendent's Handbook.

By WILLIAM MOONEY.

Consisting of Rules, Reference Tables, and Original Matter Pertaining to the Manufacture, Manipulation, and Distribution of Illuminating Gas.

350 Pages, Full Gilt Morocco. Price, by Mail, \$3.00.

A. M. CALLENDER & CO., 42 Pine St., N. Y.

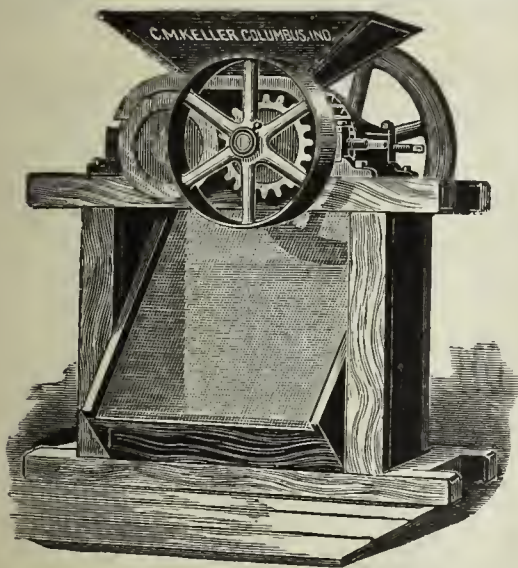

Keller's Adjustable Coke Crusher.

SIMPLE, STRONG, AND DURABLE.

C. M. Keller, Sec. & Supt. Gas Lt. & Coke Co. Columbus, Ind.

Correspondence Solicited.

King's Treatise on Coal Gas.

The most complete work on Coal Gas ever published

Three Vols. Bound, \$30.

BOOKS.

DISTILLATION OF COAL TAR AND AMMONIACAL LIQUOR.

By GEORGE LUNGE. Price \$12.50.

A TREATISE ON THE COMPARATIVE COMMERCIAL VALUES OF GAS COALS AND CANNELS.

By DAVID A. GRAHAM. 8vo., Cloth. Price \$3.

Orders for these books may be sent to this office.

A. M. CALLENDER & CO.,

42 PINE ST., N. Y. CITY

GAS METERS.

GAS METERS.

GAS METERS.

ESTABLISHED 1859.

JOHN J. GRIFFIN & CO.,

Nos. 1513, 1515, 1517, & 1519 Race St., PHILADELPHIA.
 No. 52 Dey Street, NEW YORK. No. 75 North Clinton Street, CHICAGO.

Manufacturers of Meters for Measuring Gas

IN ANY VOLUME.

EXPERIMENTAL APPARATUS FOR QUANTITATIVE AND QUALITATIVE ANALYSIS.

Provers, Gauges, Registers, Etc.

Careful and Prompt Attention paid to the Repairing of all kinds of Meters and Apparatus.

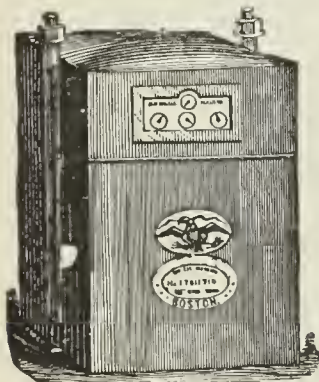
Estimates Cheerfully Furnished.

Dry Gas Meters.

With 40 years' experience and the best facilities for manufacturing, is enabled to furnish reliable work and answer orders promptly.

NATHANIEL TUFTS,*No. 153 Franklin Street, Boston, Mass.,*

MANUFACTURER OF

DRY GAS METERS.

Station Meters of any Capacity.

Test and Experimental Meters, Pressure Registers, Pressure Gauges, Pressure and Vacuum Gauges.

METER PROVERS, PHOTOMETERS, STREET LANTERNS, ETC., ETC.

Patent Cluster Lanterns for Street Illumination.

HAROLD J. BELL.

BELL & JONES,

S. LEWIS JONES.

No. 12 North Ninth Street, Philadelphia, Pa. Works at Royersford, Pa.

MANUFACTURERS OF

GAS METERS, STATION AND EXPERIMENTAL METERS,

Meter Provers, Pressure Gauges, and All Other Gas Appliances in Our Line.

WE REPAIR ALL KINDS AND MAKES OF METERS, AND THE WORK GUARANTEED.

High Pressure Meters for Natural Gas, in Iron Cases, guaranteed to stand 300 lbs. Pressure.
 Gas Cooking and Heating Stoves, Hot Plates, Cake Griddles, Waffle Bakers, Boiling
 Stoves, Laundry and Tailors' Iron Heaters. Hotel and Cafe Ranges a Specialty.

Correspondence Solicited.

Estimates Furnished.

CHARLES E. DICKEY.

JAMES B. SMALLWOOD.

CHARLES H. DICKEY.

THE MARYLAND METER AND MANUFACTURING CO.

Established 1866.

BALTIMORE, North & Saratoga Sts.

CHICAGO, 197 Michigan Street.

NEW YORK, 766 Broadway.

BOSTON, 4 Central Street.

ST. LOUIS, 1115 Olive Street.

SAN FRANCISCO, 330 Pine Street.

CONSUMERS' & STATION METERS, PRESSURE GAUGES, Etc., Etc.**"Success" and "Perfect" Gas Stoves.**

GAS METERS.

GAS METERS.

GAS METERS.

GEO. J. MCGOURKEY, Prest.

WM. H. MCFADDEN, Vice-Prest. (Phila.)

WM. N. MILSTED, Gen. Supt. and Treas. (New York).

WM. H. DOWN, Sec.

THE AMERICAN METER CO.

WET AND DRY GAS METERS.

PRESSURE REGISTERS.

METER PROVERS.

STATION METERS.

PRESSURE & VACUUM REGISTERS.

PORTABLE TEST METERS.

EXHAUSTER GOVERNORS.

PRESSURE & VACUUM GAUGES.

EXPERIMENTAL METERS.

DRY CENTER VALVES.

CRESSON GAS REGULATORS.

AMMONIA TEST METERS.

GOVERNORS FOR GAS WORKS.

MARSLAND WATER METERS.

BAR & JET PHOTOMETERS.

Manufactories:

512 West 22d St., N. Y.
Arch & 22d Sts., Phila.

GAS STOVES.

SUGG'S "STANDARD" ARGAND BURNERS,
SUGG'S ILLUMINATING POWER METER,
Wet Meters, with Lizar's "Invariable Measuring" Drum.

Agencies:

177 Elm Street, Cincinnati.
214 & 216 N. Wells Street, Chicago.
510 North Second Street, St. Louis.
222 Sutter Street, San Francisco.

HELME & McILHENNY,

(Established 1848.)

GAS METER MANUFACTURERS,

Nos. 1339 to 1349 Cherry Street, Philadelphia, Pa.,

WET AND DRY GAS METERS, STATION METERS, EXPERIMENTAL METERS, METER PROVERS,

Center Seals, Pressure Registers, Governors, Indicators, Photometers, and all other kinds of Apparatus for use in Gas Works.

FOULIS' PATENT STATION AND DISTRICT GOVERNORS.

REPAIRING DEPARTMENT.—We employ a special force of skilled workmen repairing meters of all makers.

WM WALLACE GOODWIN, Prest. and Treas.

WM. H. MERRICK, Vice-Prest.

S. L. JONES, Sec.

S. V. MERRICK, Supt.

THE GOODWIN GAS STOVE AND METER CO.,

Successors to W. W. GOODWIN & CO.

1012, 1014 and 1016 Filbert St., Phila., Pa.

142 Chambers St., New York City.

76 Dearborn, St., Chicago, Ills.

WALDO BROTHERS, Agents, 88 Water Streets, Boston, Mass.

MANUFACTURERS OF

DRY AND WET GAS METERS,

Station Meters (square, cylindrical, or in staves), Glazed Meters, King's and Sugg's Experimental Meters, Lamp Post Meters, etc., etc. Meter Provers (sizes 2, 5, and 10 feet), Pressure Gauges of all kinds, Pressure Registers, Pressure and Vacuum Registers, Pressure Indicators (sizes 4, 6, and 9 inch), King's Pressure and Vacuum Gauges, Dry and Wet Center Seals, Dry and Wet Governors, Exhauster Governors, Photometers of all descriptions. Letheby's Sulphur and Ammonia Test Apparatus complete. Also, Testing and Chemical Apparatus of all kinds, and of the most perfect description, for all purposes relating to Gas.

Manufacturers of the "SUN DIAL" GAS STOVES, for Cooking and Heating.

Goodwin's Improved Lowe's Jet Photometer.

Agents for Bray's Patent Gas Burners and Lanterns.

Special attention to Repairs of Meters and all Apparatus connected with the business. All work guaranteed first-class in every particular. Orders filled promptly.

G. B. EDWARDS, Manager, New York.

S. S. STRATTON, Manager, Chicago.

D. McDONALD & CO.,

GAS METER MANUFACTURERS.

(Established 1854.)

51 Lancaster St., Albany, N. Y.

34 & 36 West Monroe St., Chicago, Ill.

STATION METERS, EXPERIMENTAL METERS, METER PROVERS, PRESSURE & VACUUM REGISTERS, PRESSURE GAUGES, ETC

Also STAR GAS STOVES, RANGES, and HEATING STOVES.

We use only the very best materials, and employ the most skilled labor, and by our long experience (32 years) and personal supervision of every detail, we feel justified in assuring the public that our goods will give perfect satisfaction. Every Meter emanating from our establishment will bear the State Inspector's BADGE, and will be fully warranted by us. Our Annual and Calendar will be sent to Gas Companies upon application.

250 & 252
Pearl Street,

JOHN HILLEN'S BROOKLYN GAS METER WORKS.

BROOKLYN,
N. Y.

MANUFACTURER OF

IMPROVED GAS METERS

REPAIRING OF METERS (of all makers) a specialty. All defective working parts are replaced without extra charge. A guarantee is given with all work sent from this shop. Write for Price List.

GAS STOVES.

GAS STOVES.

GAS STOVES.

THE GOODWIN GAS STOVE AND METER CO.,

1012-18 Filbert St., Phila., 142 Chambers St., N. Y., 76 Dearborn St., Chicago.

Agents, WALDO BROTHERS, 88 Water Street, Boston.

WM. W. GOODWIN, Pres. and Treas.
W. H. MERRICK, Vice-Pres.
S. LEWIS JONES, Sec.

SAMUEL V. MERRICK, Supt.
G. B. EDWARDS, Mang'r, N. Y.
S. S. STRATTON, Mang'r, Chicago.

SOLE MANUFACTURERS

"SUN DIAL" GAS STOVES,

The Most Economical, Efficient, and Durable Gas Stove Made.

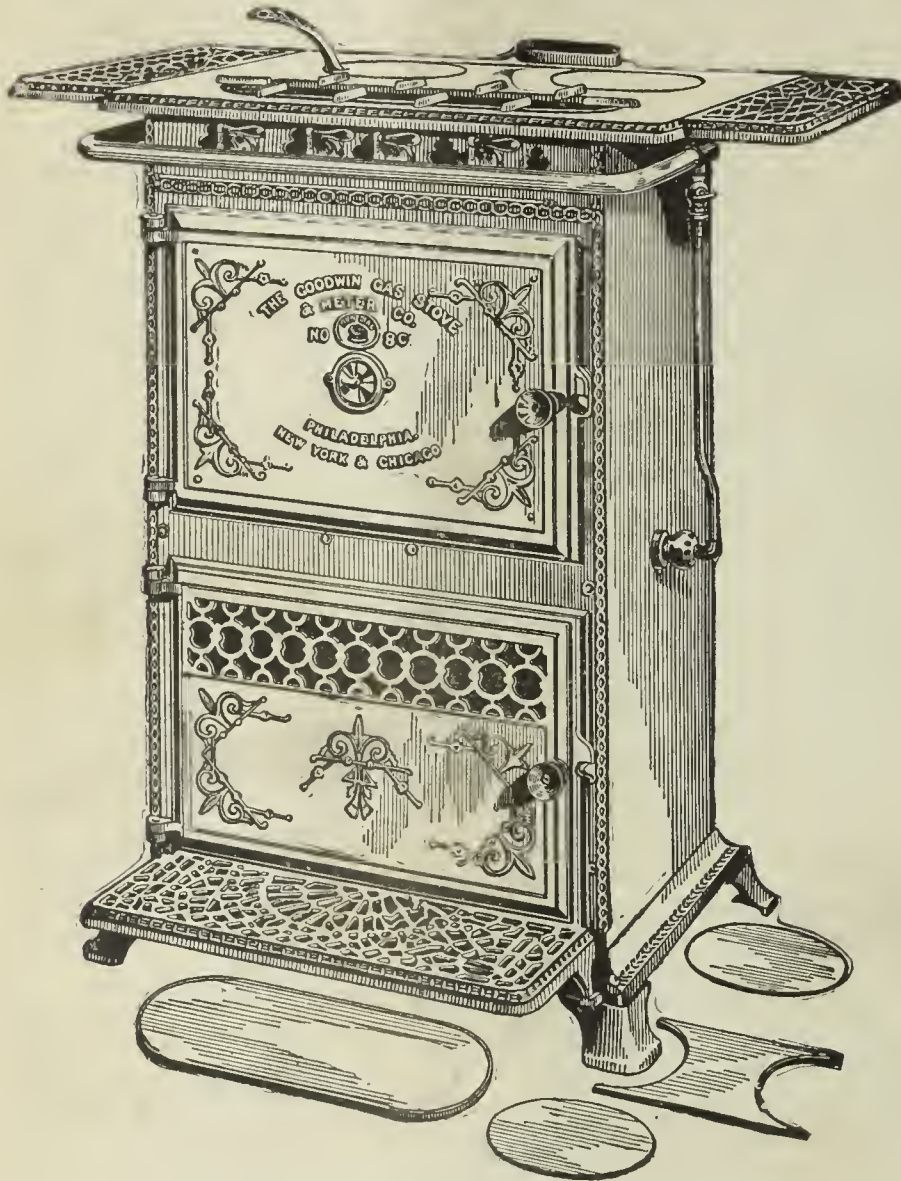

GAS COOKING STOVE, No. 8 C.

SIZE.

Stove.	Oven.	Roaster.	Top.	Length over Extension Shelves.
37 in. high. 20 in. wide.	12 in. high. 17½ in. wide. 12 in. deep.	12 in. high. 18 in. wide. 13 in. deep.	24 in. long. 21 in. wide.	36 in.

This Stove has four burners on top, and double oven burner. Consumption of gas with all burners in use, 42 feet per hour, at 1 inch pressure. The top is made in sections, so that a greater variety of cooking utensils may be used. By lifting out the covers and crosspieces and putting in a suitable forked ring, which is sent with each stove, a wash boiler or other large utensil may be set over two burners. Our No. 87 GRIDDLE also fits in the same position. The roasting oven is provided with a cast-iron door.

All Fittings are Nickel-Plated.



GAS COOKING STOVE, No. 7 B.

SIZE.

Stove.	Oven.	Roaster.	Top.	Length over Extension Shelves.
31 in. high. 17 in. wide.	9½ in. high. 14½ in. wide. 12 in. deep.	10 in. high. 15 in. wide. 13 in. deep.	21 in. long. 16 in. wide.	32 in.

This Stove has three boiling burners in the Top or Hot Plate, and one single oven burner.

This cut represents our New Style Cooking Stove. As will be seen, it has an ornamented cast-iron Base and Front, and extension shelves. The Oven Burner, which is atmospheric (unless otherwise ordered), is of an entirely new and improved pattern (patent). The ovens are of greater capacity than those of the old style. The Top, in conjunction with the Outlet Pipe, is designed to carry off all the products of combustion, if desired, but they are also supplied with a loose ring which converts it into an ordinary open top stove.

The consumption of this Stove is 35 cubic feet per hour at 1 inch pressure, with all Burners in use.

All Fittings are Nickel-Plated

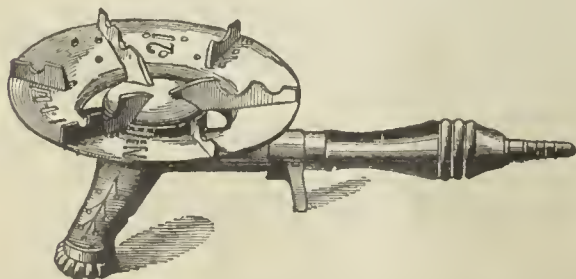

"RADIANT" BOILING STOVE, WITH REGENERATIVE BURNER.

Size, 6½ inches diameter, 3 inches high. Consumption, 6 feet per hour at 1 in. pressure.

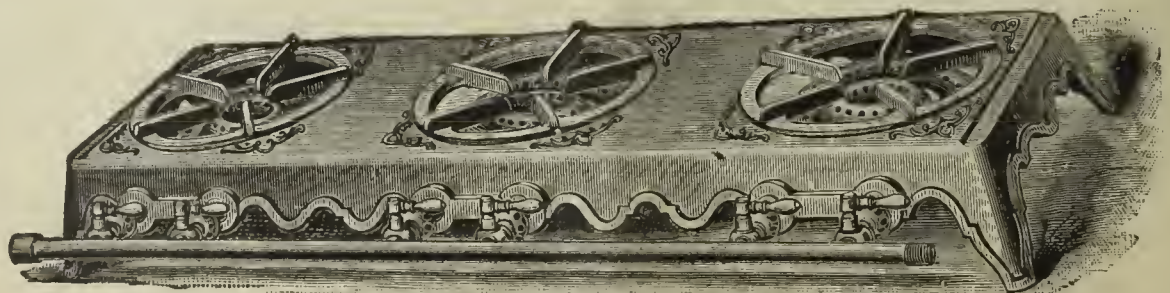

HOT PLATE, No. 111.

Size, 36 in. long, 12 in. wide, with three double burners, 6 taps. Consumption, with all burners in use, 36 cubic feet per hour, with 1 in. pressure. ¼ in. supply pipe should be used where the pressure is 1 in. or over.

THE AMERICAN

GAS LIGHT JOURNAL

REDMAN & KENNY, N.Y.

PUBLISHING OFFICE No. 42 PINE STREET

DEVOTED TO THE INTERESTS OF ILLUMINATION, VENTILATION, WATER SUPPLY AND DISTRIBUTION, & GENERAL SCIENCE.

VOLUME LII.—No. 5.
Whole No. 768.

NEW YORK, MONDAY, FEBRUARY 24, 1890.

{ \$3 PER ANNUM,
IN ADVANCE. }

A. M. CALLENDER & CO., Proprietors. C. E. SANDERSON, Manager.
JOS. R. THOMAS, C.E., Editor. T. J. CUNNINGHAM, Asst. Editor.

ENTERED AT THE POST OFFICE AT NEW YORK, N. Y.
AS SECOND CLASS MATTER.

Published on each Monday of the year, at No. 42 Pine Street, N.Y.

Terms of Subscription, Including Postage.—For the United States and Canada, \$3 per annum. European countries, \$4.50 (19 shillings—22½ francs). All payments to be made in advance. Single copies, 10 cents.

Remittances should be made either by post-office order, registered letter, or bank draft on New York, payable to the order of A. M. Callender & Co.

Collections are invariably made directly from this office, for subscriptions, advertisements, etc. We have agents to solicit the same, but they are not authorized to receipt for money.

Correspondence.—Wishing to make this JOURNAL a gazette of intelligent discussion to those of our readers who may wish to gain or give information on the subjects to which its columns are devoted, correspondence is solicited for publication from all who make the study of those subjects a pleasure or a profession.

CONTENTS.

An Asterisk (*) denotes an illustrated article.

OFFICIAL NOTICE—

Ohio Gas Light Association..... 241

EDITORIALS—

Briefly Told..... 241

Tidings from the New England Meeting—Annual Meeting, Clinton, Mass.—
Personal—Annual Report, Supt. of Public Lamps, Boston, Mass.

The Market for Gas Securities..... 242

*The Northwich Gasholder on Messrs. Gadd and Mason's Principle,
by Thomas Newbigging, C.E..... 243

Claus' Method of Producing Water Gas, and Obtaining Hydrogen,
Carbonic Oxide or Carbonic Acid, and Certain Bye-Products..... 244

The Massachusetts Board of Gas and Electric Light Commissioners
on the Subject of Water Gas..... 245

Annual Meeting, Waltham (Mass.) Gas Light Company..... 247

Twentieth Annual Meeting, New England Association of Gas Engi-
neers—Official Report, Revised by the Secretary..... 248

First Day, Morning Session: Committee on Invitations—Disposing of the
Minutes—Applications for and Election to Membership—Resignation of Mr.
Jas. Porter—Letters of Regret—Roll Call.

The Proposed Hatteras Light..... 249

Preventing the Incrustation of Boilers..... 249

The Connellsville Coke Trade..... 249

Profit in Gas Making..... 250

Tinting Incandescent Lamp Bulbs..... 251

ITEMS OF INTEREST FROM VARIOUS LOCALITIES..... 251

Refusing to Sell the Downington (Pa.) Gas and Water Works—Public Light-
ing, Centralia, Wash.—Cheaper Gas for Steubenville, O.—Defective Service
Pipes, Philadelphia, Pa.—The Holtzer-Cabot Company does not Infringe—
Sale of the Batavia (N.Y.) Gas Company—Massachusetts Gas Companies may
Pay Dividends in Excess of 10 per Cent.—Annual Meeting, Natick, Mass.—
Electric Light Shut Down at Napa, Cal.—Annual Meeting, Portsmouth, N. H.—
Prof. Ely on Gas Companies and Taxation—The Freeport (Pa.) Works Shut
Down—Changes at the Fayetteville (N. C.) Works—Annual Meeting, Jeff-
erson City, Mo.—Mr. McMillin on Fuel Gas for St. Louis—Annual Meeting, New
York and Cleveland Gas Coal Company—Complaint against Consolidated (N.
Y.) Company—The Duties of Buffalo's Gas Inspector—Regulating the Purity
of Rhode Island Gas—Annual Meeting, Salem, Mass.—Electric Rates at Mar-
tinsburg, W. Va.—Annual Meeting, Lawrence, Mass.—Public Lighting, San
Jose, Cal.

[OFFICIAL NOTICE.]

Ohio Gas Light Association.

OFFICE OF SECRETARY,
COLUMBUS, O., January 20, 1890. }

To Members of the Ohio Gas Light Association:

Gentlemen—The Sixth Annual Meeting of this Association will be held at Toledo, O., on March 19 and 20, 1890.

This announcement is made thus early in order that all members may be reminded of the meeting in ample time to make their arrangements to be present. Every member is urged not only to attend this meeting, but also to interest himself in inducing others of his acquaintance who are eligible for membership, but who have not as yet joined the Association, to come to the meeting and become members.

It is not intended that as many papers as usual shall be presented at the forthcoming meeting, in order that more time than formerly may be had for the discussion of those that are read, and for such other matters and business as the members may desire to dwell upon.

Although the Secretary has for some time been engaged in the work of soliciting papers for this meeting, he has not yet secured as many as should be had, notwithstanding fewer are desired than heretofore, and he therefore earnestly calls upon all members who can possibly do so to notify him immediately of their willingness to furnish papers.

It has been decided that an interesting and valuable feature of our meeting would be a "Question Box," in which members can place questions, which will be withdrawn and read to the meeting and answered and discussed by the members. Every member is requested to send to the Secretary at once any question or questions which he would like to have thus brought before the meeting.

Future circulars will announce further details concerning the meeting.

Respectfully, IRVIN BUTTERWORTH, Sec'y.

BRIEFLY TOLD.

TIDINGS FROM THE NEW ENGLAND MEETING.—"Boston, Mass., Feb. 19, 1890.—Those who were in Boston on the evening of last Tuesday, were inclined to be alarmed over the unusual atmospheric conditions that prevailed—conditions that were abnormal even in connection with or contrasted to those that have ruled in this oddest of Eastern winters. Hail, snow, lightning and thunder, are not often felt, seen or heard, at one and the same moment; but that melange was served up in Boston at 10 P.M. of the 18th inst. But those within the walls of Young's—and many a gas man had already visited the clerk and confided his grip to 'front,' ere the lightning flashed and the thunder crashed—cared nought for the weather. And why should they? Turning that question over to the custody of any who feels that he can answer it, I may say a decidedly loud whisper was in the corridor that Secretary Nettleton would be an absentee. This was a bit of a damper; for he has become such part and parcel of the Association in general, and the Secretary's desk in particular, that his good offices have assumed the nature of a staff. Sure enough, next morning, when in precise and trained tones Chairman Taber opened the way for business, the man from Bir-

mingham was absent. The Moses selected to show the route in respect to the Secretary's duties was no less a party than Mr. Humphreys, of Lawrence, wherefore I am led to remark that Nettleton was worthily represented. Mr. Nettleton had hoped to be back in time from a visit to the far West, as he had been hastily summoned to Grand Island, Nebraska, but it was not to be. Hastily noting that the melange of Tuesday evening was followed by clear, cool weather to-day, it is with great satisfaction I note the presence of a goodly assemblage of delegates. As is usual with the New England Association, no time was wasted in formalities, but steadily guided by the rhythmic rulings of President Taber, the order was proceeded with. One other notable thing in connection with the attendance was the presence of Honorary Members Vanderpool, Benson and Thomas, whose attendance made all the more noticeable or pronounced the absence of many whom the Association was wont to greet with favor. To report the regular business, however, is perhaps more what you and your readers desire than what has so far been written here; and with that as a guide, I can have nothing but praise for President Taber's address, although I am not entirely at one with him over some of his conclusions in respect to electric lighting. Scholarly and precise as is the usual manner of diction employed by Mr. Taber, I must say that a more beautifully rendered tribute to the memory of a dead companion or associate I have never listened to than that poured forth by President Taber over the late Mr. Cushing, of Lowell. Beauty of wording marked the tribute; depth of sentiment perfumed it, and truthfulness leavened it. Having for years been a close personal friend of deceased, I may be pardoned for this extended reference to Mr. Taber's expression of thought respecting that friend. And I know that as I feel about this sad event, so do the others of the New England Association who were privileged to call Cushing their friend. As a whole, Mr. Taber's address was of the quality that might be expected from him. He does not beg questions, but answers them. The paper list carried out its promise fully, and I must say also that Pratt's contribution completely verified the promise raised by its title. If all handsome bindings but inclosed similar 'meat,' you could always be safe in 'judging a book by its cover.' Not having at this hour heard Mr. Goodno's paper read, I am in the dark as to whether a like verdict shall apply to it; but it is quite safe to say that it shall, for Goodno is thought pretty well of 'out this way.' Of course I could not take such liberty, unsheltered from the cloak of a name that shelters one in an expression of opinion; and I assure you that many of the Eastern fraternity would like to know who 'Observer' really is. It was expected that Dr. Amory would handle his subject well; and the Doctor justified the expectation to the letter. There can be no doubt that his remarks anent the "Municipal Control of Gas and Electric Light Companies" will have close attention from your readers. Slater—another man who never begs the question, since he always answers it—told in his usual clear style about "Why I shall Make Water Gas." New Bedford seems to be especially favored in that the 'second string to its bow' at this meeting—Mr. N. W. Gifford—was in high unison with his fellow. His "Some Experiments in the Photometer Room" will likely be repeated by others when they understand how the New Bedford ones were conducted. I did not intend to make such extended reference to the papers, but their merit and importance are the excuse that I offer. Before closing this portion of my subject I should be decidedly amiss were I not to make mention of President Taber's manly utterances in respect to the value and worth of the Massachusetts Board of Gas and Electric Light Commissioners. He is all the more to be commended for this, since, if I greatly mistake not, he was not originally a supporter of the movement that resulted in the creation of the Board. However, it is New Bedford policy, as a rule, to wait until a thing has been tested ere New Bedford gives an opinion—a safe rule, too, it may be set down to be. The officers chosen to serve for the current year are:

President—Chas. F. Prichard, Lynn, Mass.

Vice-Presidents—Horace A. Allyn, Cambridge, Mass., and Wm. A. Wood, Boston, Mass.

Secretary and Treasurer—Chas. H. Nettleton, Birmingham, Conn.

Directors—Edward C. Jones, Henry B. Leach, Z. M. Jenks, Wm. Badger and E. C. Learned.

While the applications for membership this year were on the small side, it is nevertheless a fact that the available ones outside the rolls of the Association are not in very great numbers.

To-night we hold carnival in the banquet hall. That pleasure awaits us cannot be successfully denied. To-morrow it is likely that the members will inspect the plants of the Bay State Company, an invitation to that effect, extended by Mr. J. Edward Addicks, having been accepted by the Association. It does not seem necessary that I should

say the meeting is a success, but I, nevertheless, must say that such is the case.—OBSERVER."

"*Thursday*, Feb. 19.—The banquet proved a most enjoyable affair, and the business proceedings of to-day, which were carried out with dispatch, were more than ordinarily interesting to gas men. The proposed visit to the works of the Bay State Gas Company, however, had to be abandoned, a heavy snow fall, that set in early this morning, putting comfortable moving about in carriages out of the question. It is likely that some of the members will visit Waltham to-morrow, there to inspect the fuel gas plant in operation at the great watch factory. I have but time to add that the meeting marking the end of the Association's second decade was both brilliant and valuable.—OBSERVER."

ANNUAL MEETING, CLINTON, MASS.—At the annual meeting of the Clinton Gas Light Company, held on the 18th inst., the following officers were elected: President, Eli Forbes; Treasurer, Clerk and General Manager, Henry N. Bigelow. Directors, Eli Forbes, Henry N. Bigelow, Herbert Parker, John R. Foster and John E. Thayer; Superintendent, W. H. Spaulding. A reduction in gas rates (amounting to about 5 per cent. on the present schedule) was ordered. This places the prices at the following: Gross to ordinary users, \$2.50 per 1,000; net, \$2.25; other consumers, \$2 per 1,000. Extensive betterments have been made to the Company's electric plant within the last three months.

PERSONAL.—We regret to have to announce the death, at her home in Albany, N. Y., on the morning of Sunday, 16th inst., of Emeline Griffin, wife of Noel E. Sisson.

ANNUAL REPORT, SUPT. OF PUBLIC LAMPS BOSTON, MASS.—We are indebted to Supt. Geo. H. Allen, for a copy of his report respecting the operations of the Boston Public Lighting Department during 1889. From the figures presented we find that there are 9,958 public gas lamps in use, to which must be added 798 high power arcs, 300 oil lamps, and 48 naphtha lamps. The Lamp Department employs 161 men, of which 151 are allotted to the lamplighting corps. The cost for the lighting is appended:

Electric lamps.....	\$180,895.96
Gas lamps.....	229,061.54
Oil lamps.....	6,201.91
Naphtha lamps.....	1,411.90

The cost of lighting, extinguishing and repairs is returned at \$127,256.15, and the total expenditure on department account for the year is reported to have been \$593,798.23. The gas lamp contracts run until July 2, 1894, and the burning table calls for a lighting service covering 3,828 hours per annum. The burners used are fitted with an automatic regulator, and consume gas at the rate of 4 cubic feet per hour. It is also shown that the city now maintains "80 large gas lanterns," consuming from 15 to 30 cubic feet of gas per hour; but these do not seem to grow in favor, for, quoting from the language of the report, that as "the first cost of these lanterns is about \$40, and as the expense of maintenance is very large, it would be of advantage to substitute the electric light for them at an early day, provided it can be accomplished without materially increasing the expenses of the department." The total quantity of gas consumed in the lamps was 158,946,216 cubic feet, which was supplied by eight different companies, and the average cost of the supply for the entire district is \$1.453 per 1,000 cubic feet. The Boston Company proper charges \$1 per 1,000.

SOME of the storekeepers of Brooklyn (notably Baldwin, the clothier, and Wilson's restaurant proprietors) have already abandoned the use of incandescent electric lamps supplied with current from the Brooklyn Edison central station. The service was found by them to be fully twice as expensive as gas; hence the change. The ruling gas rate in Brooklyn is \$1.60 per 1,000 cubic feet.

The Market for Gas Securities.

The city market for gas shares shows no change, unless it may be said to have shared, in common with the market for railroad securities, in the weakness of the demand from investors, whose dividends have evidently been placed. Consolidated is at 96 bid, which shows that even a weak general market has no power to affect it greatly. Mutual is up to 109, and it would not surprise us to see it go higher. Brooklyn shares are steady to strong. Baltimore Consolidated is weak, probably on realizing sales; and Chicago Trusts are lower. Laclède common is offered at 15. Eastern shares are all in the line of higher figures, and this observation applies with great force to the Massachusetts companies. Can it be that the State Gas Commission is partly responsible for the feeling of security that prevails among shareholders there?

The Northwich Gasholder on Messrs. Gadd and Mason's Principle.

By THOMAS NEWBIGGING, C.E., in the *London Journal*.

Since the reading of my paper before the Manchester District Institution of Gas Engineers, at the meeting held at Doncaster about 18 months ago, at which the invention of Mr. Gadd was first prominently introduced and described, down to the present time, I have resisted the temptation to speak or write at length on the subject, believing that the best

of the outer or lower lift is 60 feet; and of the inner or upper lift, 58 feet. The average diameter is therefore 59 feet. The height to which it rises when fully inflated is about 38 feet; the total height of 40 feet being reduced by the cup and grip and the bottom seal.

The top curb of the inner lift consists of two angle-iron rings 4 in. by 3½ in. by ½ in., and 5 in. by 3½ in. by ½ in. The roof framing is of the usual kind, consisting of a series of main rafters, 3 in. by 4 in. by ½ in., trussed on the bowstring principle, secured to the curb at the outer end, and at the other end to the center or crown plates at the head of the king post.

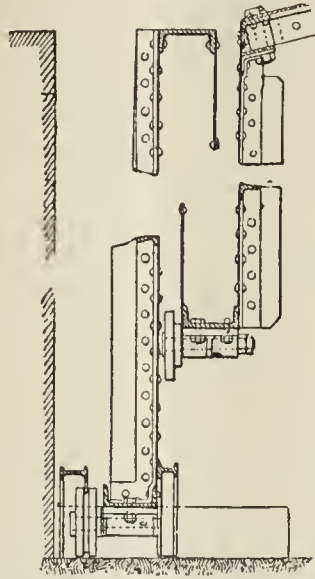

Section through Cup and Grip.

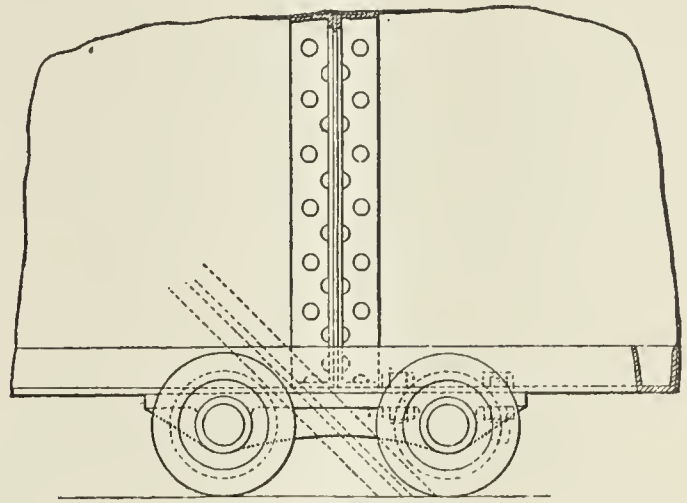

Elevation of Carriage.

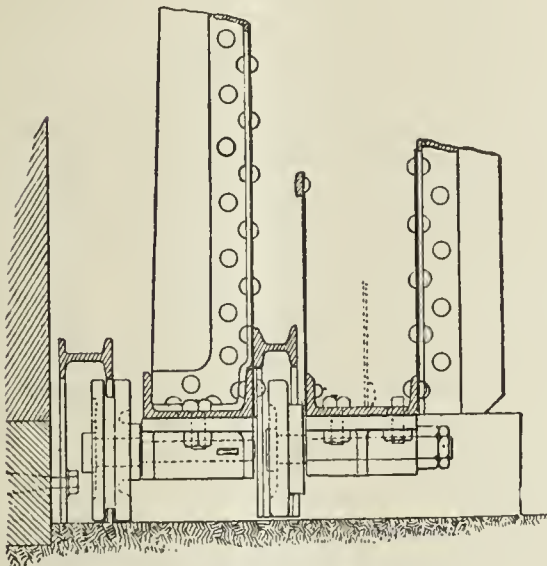

Section through Cup and Curb.

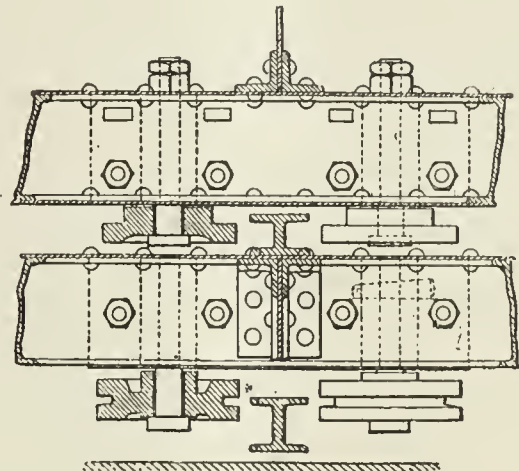

Plan of Carriages

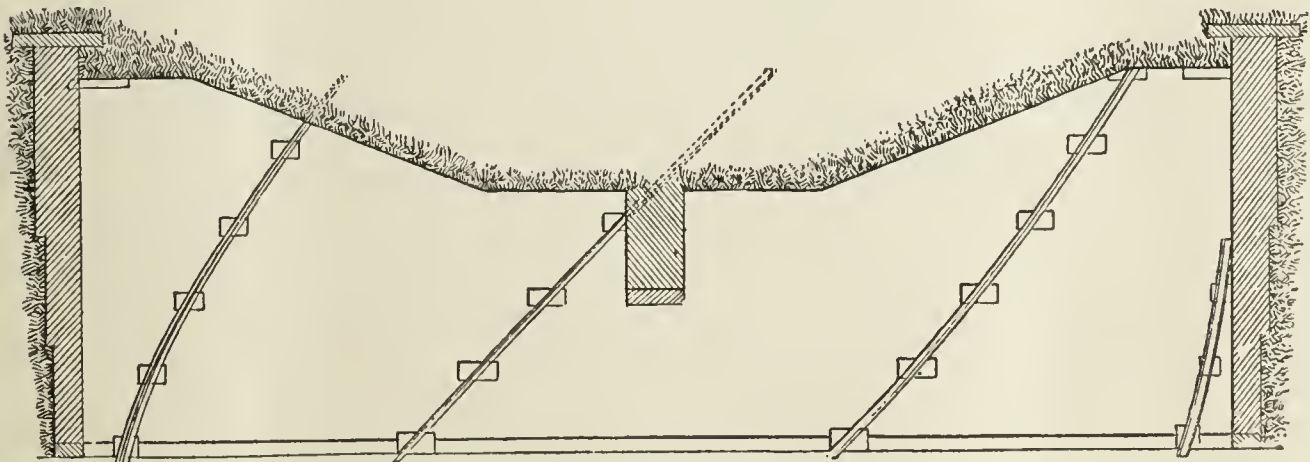

Section through Tank.

illustration of the value of the invention which is so great an innovation on all that has previously been suggested or attempted in this direction, would be its presentation in the shape of a practical working example.

Now that the new principle of guiding has become an accomplished fact in the holder that has just been completed and put to work at Northwich, it is neither necessary nor desirable that I should longer refrain from a detailed reference to the merits of the new system. The best form this can take at present is obviously that of giving a full description, with illustrations of the holder.

The vessel is telescopic, in two lifts, each 20 feet deep. The diameter

The secondary rafters are of flat iron, 3½ in. by ½ in. The main tie rods are 1½ in. diameter. There are 16 vertical stays, each of 3 in. by 3 in. by ½ in. angle irons, with a piece of ½ in. plate riveted between in the inner lift. The hydraulic cup and grip are of the usual construction, 18 in. deep by 8 in. wide. The vertical stays of the outer lift are also 16 in number, one-half of them being made rather stronger than the other, and are ranged on the outside of the vessel, so as to admit of the guide rails being placed inside. The bottom curb is of channel iron, 8 in. by 3 in. by ½ in., and projects from the holder towards the tank. This curb, for single-lift holders, would answer equally well if placed inside; and even in telescoped vessels its adaptation in this way is possible. The

roof sheets are 10, 12 and 14 B. W.G. The holder is surmounted by a handrailing 2 feet in height.

I have been thus precise in describing the holder in order to show that the details throughout are substantially those of other holders guided in the ordinary way; the only difference being that the trussing is heavier than is usually adopted. I am now perfectly satisfied, however, that any additional strength or weight in this particular was quite unnecessary; and from the experience I have gained should have no hesitation in designing and constructing a holder to be guided under the changed conditions of materials as light as, or even lighter than, those of one guided on the old principle.

And now as to the guiding arrangements, which form the new departure. They are of the simplest character (which indeed is their chief merit), and require but little description. They consist for the outer lift of eight steel rails of H section, 4 in. by 3 in. by $\frac{1}{2}$ in., placed against the tank wall at an angle of 45° , and attached to the coping of the tank, and at four other equidistant points in their length by jagged bolts let into stones built into the brickwork. The rails for guiding the inner lift are the same in number, and nearly the same in section—3 in. by 3 in. by $\frac{1}{2}$ in.—the web being shorter, placed at the same angle, riveted at distances of 12 inches apart to the side sheets, to the vertical stays at the point of intersection, and secured top and bottom by means of lugs to the grip and curb respectively. The guide-rollers, one on each side of each rail, are of steel, and are 10 inches in diameter, revolving on 2-in. wrought iron axles, attached to cast iron carriages bolted to the bottom curb on the outer lift, and to the cup of the inner lift. The rollers on the latter work within the channel against the web; and the former, which are grooved, clip the outer table of the rails. These several details are shown in the accompanying illustrations, and will be readily understood. In the next holder of the kind a few modifications—chiefly in the method of fixing the guide-rails and carriages—will be introduced. It will thus be evident that in rising and descending the vessel has a helical or screw-like movement, and turns, in the course of its ascent to its full height, a distance of one-fifth of its circumference. The full pressure given by the holder is 7 inches; and by the bottom lift, $4\frac{1}{2}$ inches. There is scarcely any perceptible difference in the indicated pressure during the ascent and descent.

The actual saving in weight of the total structure, as compared to what would have obtained had the holder been guided by upper framing composed of eight wrought iron standards having cast iron base plates, and braced with lattice girders, and the necessary wind ties, is 36 tons. The slightly increased weight in the bottom curb and spiral rails in the lower lift, does not exceed 2 tons, which will be a deduction from the above. What the cost of the additional material for the upper guide framing, finished and erected, would have been can therefore be easily reckoned. It amounts to at least £600; and this sum may be taken as representing the saving, at current prices, which is effected in the practical application of Mr. Gadd's invention to the comparatively small structure under consideration. It is to be remembered, also, that the tank being built without the usual brick piers and heavy base stones for standards or columns, necessarily costs less than one having these additions.

The contractors for the holder (Messrs. Clayton, Son & Co., Limited, of Leeds) experienced but little difficulty in bending the rails to the peculiar curvature (resembling that of a winding stair rail) which they had to assume, or in the attachment of them to the sides of the tank and holder. Certainly, if any slight difficulty did present itself in regard to these it will disappear in carrying out future work of the kind.

I have elsewhere remarked that in applying the principle to a two-lift holder of only 60 feet diameter, each lift being 20 feet high, or, together, two-thirds of the diameter, the test to which the invention has been put is a tolerably severe one. The conditions of stability in a holder of, say, 200 feet in diameter in three lifts of 40 feet each, are palpably superior by a difference of 10 per cent. to those which obtain in the present structure. In other words, if the two lifts in the Northwich holder were reduced from 20 feet to 18 feet in height each, the comparison would be equal—though, of course, it may be argued that the wind pressure at the higher altitude is usually stronger.

The Northwich holder, whilst inflated with gas to a height of 30 feet, has already been tested under stress of a series of strong gales which have occurred, and it has not shown any movement worth recording. Of the stability of the structure under any wind strain to which it is liable to be subjected, I have no doubt whatever; and I am convinced that the more closely the principle of its action is investigated and studied the more evident it will appear that, as compared with the old method of gasholder guiding, the new system, for efficiency, economy and beauty, takes a vast stride forward.

Claus' Method of Producing Water Gas, and Obtaining Hydrogen, Carbonic Oxide or Carbonic Acid, and Certain Bye Products.

According to the London *Journal*, English Letters Patent (No. 50, Jan. 1, 1889,) have been granted to C. F. Claus, of Suffolk House, London, for a method of securing the results outlined in the above heading. Our authority states that the somewhat lengthy specification of this invention is not accompanied by drawings of the plant proposed to be employed in carrying it out. The patentee explains that the gaseous mixture (consisting principally of carbonic acid, carbonic oxide, and hydrogen) commonly called "water gas," and which is now produced extensively by various methods, forms the basis from which he obtains, by the processes now to be described, hydrogen, carbonic acid, and carbonic oxide, each separately, and in a more or less pure condition. The water gas for his purposes can, of course, be manufactured in some other manner; but he prefers to produce it by the means claimed in the present invention.

He passes an uniform and continuous stream of highly superheated steam through a deep layer of fuel—preferably smokeless fuel, such as coke or anthracite—whereby the water or steam is decomposed, and forms, according to the depth of the layer of fuel or the temperature of the incoming superheated steam, either mainly carbonic acid and hydrogen, or principally carbonic oxide and hydrogen, or mixtures of carbonic acid, carbonic oxide, and hydrogen. In the ordinary mode of producing water gas, it is the practice to fan ignited fuel by means of blasts of air into a state of high incandescence; and steam is then passed through the hot fuel so long as the temperature remains sufficiently high to decompose it into hydrogen, carbonic acid, and carbonic oxide. After the fuel has become too much cooled down to have this effect, the steam is shut off, and the air blast is again admitted until the desired heat is once more obtained, when steam is re-admitted, and so on alternately. In the present process, however, the current of steam is superheated to such an extent that, in passing through the fuel, it will cause the ignition thereof, and will maintain it at a temperature sufficiently high to ensure the decomposition of the steam into a gaseous mixture consisting of the gases already mentioned; no air blast being used for promoting the combustion of the fuel, and there being no necessity for previous ignition of the fuel. A furnace similar to a blast furnace or lime kiln is used as the receptacle for the fuel, built of thick brickwork, and covered outside by gas-tight ironwork, as are the conduits and gas connections. The fuel, as it becomes consumed by the superheated steam, is replenished from the top through an opening, and the ashes are withdrawn from an opening (capable of being closed by a door) in the bottom of the fuel receptacle.

For superheating the steam, apparatus somewhat similar to a Whitwell regenerative and alternately working blast heating stove is used in such a manner that, whilst the steam is passing through one part of it, the other portion is being heated to the requisite temperature; and, when the one part has become cooled down to a temperature no longer high enough for properly decomposing the steam, the current is turned into the other part that has been heated up in the meantime. The direction of the current of the heating gases being changed in a corresponding manner, this current is turned into the part of the stove which has been cooled down by the steam passing through it, and so on continually. The result is that one part of the stove is always at a sufficient temperature to ensure the decomposition of the steam.

As soon as one or more of the chambers are cooled down, they are shunted out from the course of the steam, and connected with the circuit of the chambers which are being heated by the generator gases. When heated to the required temperature, they are again connected with the steam circuit; and a corresponding number of cooled chambers are simultaneously connected with the circuit of the heating gas, and so on continually. The gases and the steam to be heated travel in the same direction through the chambers; and in this manner, a number of chambers are continually heated, while an equal number are having their stored up heat abstracted by the steam passing through them.

After the heating of the chambers, they are full of the products of combustion of the producer gas. To prevent the water gas being contaminated by this, a blast of steam is sent through the chambers, to drive out the products of combustion before the re-admission of steam to be superheated. This may be done by the steam blast entering direct; but it is preferred to do so by first passing the steam through the ordinary generator, and then through the chambers—the air supply to the ordinary generator being stopped for the time, and whilst the steam jet passing through is being used for the purpose named. The patentee's object is to obtain the whole of the water gas produced for use for the purposes for which it is manufactured, and not to use any of the gas for

heating the chambers or regenerators. He therefore effects the heating of the Whitwell stoves employed for the purpose by means of less valuable ordinary producer gas, obtained in the well-known manner from any kind of fuel, either with or without the aid of steam, and does not use any part of the water gas produced for heating any of the apparatus connected with its manufacture. He thus claims to obtain nearly double the quantity of the more valuable water gas than is usual in the ordinary mode of working.

The gases which are produced by the action of the superheated steam upon the fuel are either: (1) Principally carbonic acid and hydrogen; or (2) principally carbonic oxide and hydrogen; or (3) a mixture of carbonic acid, and carbonic oxide, and hydrogen. These are all accompanied by the ammonia which is simultaneously formed by the action of the superheated steam upon the nitrogenous matter contained in the fuel wherewith the water gas is produced. By using steam alone and dispensing with an air blast acting upon the fuel, and by passing the steam in a continuous current through the fuel, the whole of the fuel is consumed by the steam alone, and practically the whole of the nitrogen in it is converted into ammonia available for recovery by a process described later on, instead of only part of it, as in previous processes.

To separate the carbonic acid from the hydrogen, or from mixtures of carbonic acid, carbonic oxide, and hydrogen, and to recover at the same time the ammonia above referred to, the patentee first reduces the temperature of the mixed gases. This is carried out by employing the heat inherent in the gases after they leave the generator, in two separate operations—viz., in the heating of the ammoniacal scrubber liquor, and in distilling it after it has been heated by means of this heat. The gases become cooled by these operations; and after they are thus cooled, they are passed through a series of scrubbers wherein they are brought in contact with free ammonia either in a gaseous or liquid state, whereby the carbonic acid becomes absorbed, whilst a solution of carbonate or sesqui-carbonate of ammonia is formed. The residual hydrogen or carbonic oxide and hydrogen gas is conveyed into a gasholder; and the solution of carbonate of ammonia formed in the scrubbers is heated by the hot gases. The greater part of the carbonic acid is thereby driven out and collected in a holder for use; and the free ammonia left behind in the liquid is distilled off by means of the hot gases, and is returned to the scrubbers to there take up more carbonic acid from a fresh quantity of gases—a certain stock of ammonia being kept for that purpose in constant circulation throughout all the apparatus, as in the now well-known Claus arrangement for gas purification.

After giving a very elaborate description of the process, of which the above is a mere outline, the patentee proceeds to describe how he proposes to separate the carbonic oxide and hydrogen and to obtain them separately. He says: When water gas is produced which contains carbonic acid, or when it has intentionally been produced with a large percentage of it, which has been removed by the process already described, and the ammonia, which may have been associated with it in one way or another, has been removed and recovered from it, the two residual gases, carbonic oxide and hydrogen, have by that operation been cooled down. They are then heated up again to a temperature somewhat above that at which hydrogen will reduce oxide of iron—say, to about 400° to 500°—but below that at which carbonic oxide will do so. This heating of the gaseous mixture may either be accomplished by means of a heating stove, such as that described for the superheating of the steam, or (as the temperature required is a comparatively low one) in stoves such as those used in connection with blast furnaces, consisting of a number of inverted U-shaped pipes. When the gaseous mixture has been heated up to the temperature above mentioned, it is passed into one of a set of six, eight, or more chambers filled with porous (yet firm) pieces of oxide of iron, and which are worked in rotation. After passing through the first kiln, the mixture flows into the second, and so on through the whole series. The hydrogen is by this operation separated from the carbonic oxide, by forming water with the oxygen of the oxide of iron and spongy metallic iron. The water formed is condensed; and the carbonic oxide is conveyed to a holder for use. The oxide of iron kilns are closed ones—connected, however, by means of iron tubes thickly lined by bad conductors of heat. They communicate with one another by pipes so arranged that any one or more of the kilns may be shunted out of connection with the others by means of valves. They are further so arranged that the gaseous mixture may be turned into any one of them, and, by similar means, the exit gases may be taken out of any one of them. The heated gaseous mixture enters one kiln of the series; and the part of the mixture which passes through the kiln enters the next kiln, and so on—the gas from the last kiln passing into a holder. As soon as the oxide of iron in the kiln into

which the gaseous mixture first entered has become converted into metallic iron, the gaseous mixture is turned off from this kiln, and into the next kiln, which thus becomes the first in the series; and so on continually. The effect of this is that each kiln in its turn becomes first, intermediate, or last in the series. The kiln which contains the oxide of iron converted into metallic iron sponge, when shunted out from connection with the other kilns, is then connected with the hydrogen holder, and steam (superheated as described) is passed into it; and the hydrogen thus formed is conveyed into the holder. The superheated steam is, however, with more advantage passed successively through several of the kilns containing the metallic sponge; entering the one connected with the heated gases first, and leaving that connected last with the heated gases. When the metallic iron sponge contained in the kilns has, by the action of the superheated steam, been converted into oxide of iron, the first of the kilns is disconnected from the hydrogen holder, and again connected with the set of oxide of iron kilns, through which the gaseous mixture is passing; and this kiln then becomes the last in the series—a *modus operandi* the advantages of which will be understood without further description.

The Massachusetts Board of Gas and Electric Light Commissioners on the Subject of Water Gas.

[From advance sheets of the Fifth Annual Report from the Board, and reprinted with the consent of the Commissioners.]

The Board since its last report has continued its investigations on the subject of water gas. It is understood that the parties in interest do not desire to offer further evidence in the cases pending at the close of the year. The Board believes that some modification of the present law is desirable, and that a report of the work of the Commissioners in this branch of their duties ought to be made to the Legislature at the present time.

In the course of its inquiries the Board has endeavored to ascertain what commercial advantages, if any, might accrue to the companies from an extension of the present statutory limit of carbonic oxide, believing that in any such advantages the consumers would ultimately share, and that the companies ought to be permitted to avail themselves of them, if they could do so without prejudice to the public interest. For this purpose information has been obtained by personal inspection and correspondence from more than a hundred companies. The Board desires to gratefully recognize the uniform courtesy which has been freely extended it by the engineers in charge of water gas works in other States, and to acknowledge its obligations for the information so freely furnished.

It is clear that the cost of gas, whether coal or water, is not an inflexible figure, the same for all times and places; an advance of 50 cents per ton in coal or of one cent per gallon in oil, making an increase of 10 per cent. in the cost of coal and water gas respectively. In certain large works where both kinds of gas have been made, the advantage in cost of production has been sometimes with one, sometimes with the other kind of gas. There are more exclusively water gas works in the anthracite coal region in Pennsylvania, and within easy reach of it, than in any other portion of the country of the same area; because there the price of anthracite coal has been low, and that of gas coal relatively very high. The particular location of a gas works and its arrangement, the quality of the materials and kind of apparatus used, and the kind of labor and superintendence available, may make even larger variations in the cost of either gas.

The expenses of distribution, management, taxes, etc., are not likely to vary greatly, whether coal or water gas is the product; so that the fact of value in estimating the cost of the two gases is the cost to manufacture or cost in the holder, as distinguished from cost at the meter.

The principal items of cost in the holder are for materials, coal and oil, labor and repairs. From the cost of materials in coal gas is to be deducted the very considerable receipts from the sale of coke, tar and ammoniacal liquor. Under the best conditions in this State these receipts have reached 50 per cent. of the cost of coal, and in some companies more favorably situated they have reached a much higher percentage.

A ton of good gas coal will yield approximately 10,000 to 11,000 feet of gas. In order to secure the candle power usually supplied in this State there must be added about 10 per cent. of cannel, or something more than 5 gallons of oil, equivalent to more than one-half gallon per 1,000 feet.

In the production of illuminating water gas there is commonly used more than 50 pounds of hard anthracite coal, and from 5 to 6½ gallons of oil for every thousand feet of gas, although in the very best works

and under very favorable conditions these quantities may be slightly reduced. These two items nearly make up the cost of water gas in the holder.

In coal gas the cost of labor is a most important element. It often nearly equals one-half the gross cost of materials, and in many companies does not vary much from the net cost of coal. In water gas the cost of labor is small.

It has been very difficult for the Board to obtain definite and reliable information as to the cost of repairs in water gas works. It is not a very considerable item in coal gas, and is probably about one-half as much in water gas.

The following figures show the range of cost in certain companies, each item being calculated independently of the other, and, it is believed, fairly indicate the difference of cost in the holder of the two gases :

MATERIALS.	
<i>Coal Gas.</i>	
Gas coal.....	40 to 43 cents.
Oil or cannel.....	3 to 7 cents.
Residuals.....	13 to 23 cents.
Net, for materials.....	20 to 30 cents.
Labor.....	14 to 20 cents.
Repairs.....	5 to 8 cents.
Total.....	50 to 57 cents.
<i>Water Gas.</i>	
Coal.....	11 to 15 cents.
Crude oil.....	13 to 18 cents.
Naphtha.....	24 to 33 cents.
Materials.....	26 to 33 cents.* 38 to 45 cents.†
Labor.....	5 to 11 cents.
Repairs.....	2 to 3 cents.
Total.....	46 to 55 cents.

The figures relating to coal gas are taken from the returns of certain companies in this State, as made to the Board. The figures relating to water gas are estimates based upon information procured without the State, and intended to show what the same companies might do at current rates for materials, if they were making this instead of coal gas. It may be noted that the companies now making water gas in this State have not yet been able to equal the figures given. The relations shown above may be greatly changed at any time. The figures given for naphtha and crude oil are suggestive. A few years ago, when the number of water gas works was small, the price of naphtha was about the same as that of crude oil to-day. As the demand for naphtha for gas making purposes increased, the price advanced to a point which nearly neutralized the advantages of its use. Recently a crude oil, from the Ohio fields, difficult to refine, has come upon the market at a low price, and an apparatus specially adapted for it has again reduced the cost of water gas to the low point reached when naphtha was first introduced. There are now signs of an advance in its price.

There have been great improvements in water gas apparatus, and there is much activity in this direction now. It is now claimed that cheap bituminous coal and slack can be made to do the work of expensive anthracite; and, if the expectations of the inventors of this new process are realized, the cost of producing water gas may be greatly lessened.

In companies whose output is below a certain limit, the peculiar condition under which they make gas causes the cost to vary greatly from the figures given above. In these the cost per 1,000 feet for both coal and labor rises rapidly where coal gas is made. There is little or nothing obtainable from residuals, as all or nearly all the coke is used to carbonize the coal, and the production of gas per man is much reduced, since of necessity the gas maker must be idle much of the time. In a properly constructed water gas works of very small output, while the cost of coal may be easily doubled by the necessity for frequently cooling and reheating the apparatus, the cost of labor is not materially different from the same item in large works. In a single day one man may make and store water gas sufficient for several days' consumption, during which the works need no attention, and the gas maker can devote himself to the numerous other details of the business. Instances have been observed by the Board, in other States, where small works have been carried on in this manner with apparently good results. For reasons not easy to enumerate, the attempts by small companies in this State to pursue a similar course have not heretofore been entirely successful.

Although in the larger works, except in favored localities, the commer-

cial advantages of manufacturing exclusively coal or water gas may not be considerable, with the methods and apparatus now most in use, the advantage to company and consumer in the combination of the two gases is now generally recognized by the larger companies, and nearly one-third of all the companies in the country manufacture some water gas. The development of electric light, combined with other causes, has greatly increased the public demand for light; a gas of 15 or 16 candles is no longer acceptable, and from 18 to 20-candle gas is as low as companies in the larger towns and cities think it wise to distribute. Gas of this quality cannot be produced with ordinary coal alone, but requires the addition of cannel coal or of oil; which latter, from its low cost and the facilities for handling, has been most generally adopted. For this use of oil the ordinary appliances of a coal gas works are but poorly adapted. When oil is used in them, it has shown a decided tendency to pass with the coal gas as a vapor, much of which is subsequently deposited in the mains or fixtures in a liquid form, or, by causing a hard substance to form at the tip, obstructs the flow of gas, and causes the forked and irregular flame so common where such gas is used; and the gas often manifests an uncontrollable tendency to smoke. To a high candle power secured in this way is often due the blackened spots in the ceilings of dwelling houses where such gas is used.

A water gas apparatus affords the means for avoiding these difficulties. In this the heats best adapted to breaking up the oily particles into a fixed gas may readily be attained, and gas of a very high candle-power be made. When coal gas is made at the same works, and the two are mixed in the proper proportions and best manner, the unfortunate results mentioned as due to oil should not occur. The gas is composed of the same constituents, but in different proportions, and reaches the burner with that combination of heating and illuminating elements calculated to produce a clear, white flame, free from smoke.

Numerous other reasons suggested by local conditions have induced companies to add to coal gas works apparatus for making water gas. It enables a company to easily meet a sudden demand for an unusual amount of gas. It can be made ready for gas making at an hour's notice, then allowed to cool when the demand is over, and this course repeated indefinitely without injury, while coal gas benches once treated in this manner would probably need rebuilding. An unexpected dark day may thus be readily provided for, and the considerable changes in consumption where street lights are burned by moon schedule, but are unexpectedly called for on stormy nights. In some places the increased consumption has made necessary some increase in the capacity of the works, which has been secured with less expense for extension by the introduction of water gas apparatus, with a consequent saving in capital account. A brief period of extraordinary consumption in midwinter is sometimes provided for in this way. In many works where both kinds of gas are made, coke produced at the works is substituted for anthracite coal, furnishing a profitable use for surplus coke, and preventing a reduction of its price.

These are some of the indirect advantages resulting from a manufacture of both kinds of gas in the same works. They are quite independent of whether one gas made alone costs a little more or less than the other. To secure them requires the distribution of a gas containing somewhat more than 10 per cent. of carbonic oxide.

The question of the comparative safety of water and coal gas is a very perplexing and difficult one to solve satisfactorily. One or more members of the Board have personally examined the premises where a large number of deaths have occurred from asphyxiation by inhaling illuminating gas in Brooklyn, New York city, Baltimore and other cities. A few of these deaths were caused by coal gas, others probably by a mixed gas; but the larger number were due to water gas. Some valuable suggestions have been obtained from these inquiries, although great difficulty was experienced in securing exact or definite information. It was impossible, for instance, in most cases to ascertain the length of time the gas was discharged into the room; and in many cases the size of the burner, and whether partially or wholly open, were only matters of conjecture. Most of the accidents investigated occurred at the cheaper boarding and lodging houses. It was found in one city—and the same facts also applied to the others in a less degree—that a very low price for gas, great activity on the part of competing companies in canvassing for customers, and the very favorable terms that were made for piping buildings and furnishing fixtures, had led to the introduction of gas into the very cheapest lodging and boarding houses that are frequented by the dissolute and ignorant classes. In several instances it was evident that the inhaling of gas alone would not have produced death, but caused it by aggravating diseases existing at the time of the accident. Some of the rooms contained less than 500 cubic feet of space, and the average space of all the rooms was about 1,100 cubic feet. The largest

* Crude oil. † Naphtha.

amount of gas was 75 cubic feet, as nearly as could be ascertained, in a room containing 748 cubic feet of space; but there was an open transom at the time of the accident, and the person lived 12 hours after being discovered. The smallest amount of gas was 18 cubic feet, in a room containing 806 cubic feet of space; and the person was dead when found. The average amount of gas in the rooms was about 38 cubic feet. But, as before intimated, the information in regard to the amount of gas in the rooms where deaths occurred is unsatisfactory. In three instances, where a man and a woman occupied rooms together, the men died and the women recovered.

In addition to these investigations the Board has obtained, from newspapers and other sources, information in regard to the deaths of 107 persons in this country from inhaling illuminating gas during the year 1889. This is probably not the whole number of deaths from this cause, but perhaps complete enough to give some facts of interest in considering the question of danger from illuminating gas. There is conclusive evidence that 30 of these persons committed suicide, and there were circumstances attending the deaths of several others that indicated more or less strongly the same cause. But, deducting from the whole number only those suicides about which there can be no doubt, there were 77 deaths caused by accidentally inhaling illuminating gas. These occurred in the following towns and cities, viz.: Yonkers, N. Y., 1; Baltimore, Md., 7; Oakland, Cal., 3; Jersey City, 2; New Brunswick, N. J., 1; Amesbury, Mass., 1; Paterson, N. J., 6; Huntington, Pa., 1; and Bethlehem, Pa., 3. In these places only water gas is believed to be manufactured. In New York city there were 24 deaths; Philadelphia, 2; San Francisco, 7; Chicago, 5; Brooklyn, 3; Washington, D. C., 2; Minneapolis, 1; Charlestown, Mass., 1. In these towns and cities a mixed coal and water gas is made, or there are coal and water gas plants in operation. There was 1 death in Cincinnati; 2 in Milwaukee; 1 in Lincoln, Neb.; 1 in Belleville, Ill.; and 1 in Portland, Me. These have only coal gas plants. The following are the number of deaths for each month, viz.: January, 9; February, 5; March, 6; April, 3; May, 5; June, 7; July, 1; August, 1; September, 5; October, 10; November, 11; December, 12.

Forty-six of the deaths occurred in hotels—generally of the cheaper class—lodging and boarding houses, where the rooms were usually small and poorly ventilated. In 18 of the accidents the gas was blown out by ignorant persons, and in 46 instances it was found turned on without any satisfactory evidence as to the cause. In 8 instances death was caused by gas stoves, in 1 by a leaking pipe, and in 3 by defective keys where the gas is turned on at the burner. Twenty-five of the persons killed were females, and 52 were males. Of the males, 17 were business men, 4 farmers, 2 professional men, 6 laborers, 2 sailors, 2 mechanics, 1 janitor, 1 railroad man, 1 teamster, 1 bartender, 1 waiter, 1 student, and 7 unclassified. Ten of the females were servants. In 20 cases the persons were more or less intoxicated at the time of their deaths.

It will be seen that 26 of the deaths occurred in places where only water gas was manufactured, 6 in those having only coal gas plants, and 46 in towns and cities where is furnished a mixed water and coal gas, or where there are plants of each gas. The largest number of deaths was 24, in New York city. In New England, where 14 cities and towns are furnished with water gas and 6 with a mixed water and coal gas, there were 3 deaths. One of these resulted from inhaling water gas, 1 from coal gas, and the third one was caused by a mixed water and coal gas.

Some of the inferences to be drawn from the above facts are that about 30 per cent. of the deaths from illuminating gas are suicides; that about 20 per cent. are persons more or less intoxicated at the time of the accidents, and a considerable number are persons unacquainted with the use of gas. A comparatively small number of cases are purely accidents that could not have been avoided.

From the fullest consideration which the Commissioners have been able to give to the Act, chapter 428, Acts of 1888, they believe that the correct interpretation of the statute does not permit them to issue a revocable license or one subject to modification, to impose any terms or conditions in the exercise of it, or to qualify in any manner the certificate which the license must contain, "that in their opinion the gas can be used with safety" for illuminating purposes. The degree of danger in the use of coal gas, water gas, or a mixture of the two, depends largely on the amount of carbonic oxide it contains. It is probably true that the Legislature of 1880 fixed the limit of carbonic oxide at 10 per cent. because that limit was not exceeded in the manufacture of coal gas, and not because it was safe. Many reliable gas engineers now believe, and have expressed the opinion to the members of the Board, that commercial necessities exist at the present time for permitting a larger

percentage. The danger which appertains to the careless use of all the gases named is an obstacle, in the minds of the Commissioners, against granting a license in the form contemplated by the statute. Coal gas is used for illuminating purposes, not by reason of its elements of safety, but because of its ease of distribution, convenience, neatness, economy, and the excellence of its light. Its dangers are widely known. Water gas or a mixed gas is somewhat more dangerous; but should its use be wholly prohibited, if the present state of the art shows that in some communities a better and cheaper light can thereby be supplied, and the increased risk can by care be overcome?

In many cities and towns a mixed gas is served, containing from 10 to 20 per cent. of carbonic oxide; in others, water gas having from 25 to 30 per cent. of the same constituent. In these places, as a rule, the question of safety or danger does not enter into the calculation; the managers of the gas companies there simply consider the economy and quality of the light, and the same is true of the consumers. As the accidents are chiefly caused by ignorance or carelessness, the general public feels no alarm, as people do not ordinarily charge themselves with being either careless or ignorant. But all intelligent persons agree that too much caution cannot be exercised. When used by watchful, careful consumers, almost any gas can be called safe; but in the hands of the careless or ignorant, the same gas will be dangerous. The more poisonous gas can perhaps be made practically safe by keeping the gas pipes and fixtures tight, by the use of smaller burners, or by providing ample means of ventilation if the gas by any means should escape.

If a thing in itself be dangerous, the knowledge of its character and a warning in its use are likely to prevent harm. How can a certificate of safety be attached, without misleading the very ones whom it is desired to make more careful? Although a mixed gas or water gas is somewhat more rapid in its poisonous effects, if inhaled, than common coal gas, is it not quite probable that a little more care on the part of those who distribute and use the gas may fully offset the increased element of danger it contains? The mere knowledge that it is more harmful would naturally lead people to be more careful. Some of the accidents are caused by defective fixtures or burners; these could be inspected and kept in repair. A company might be required to examine them periodically. If the proportion of carbonic oxide be extended, especially to the degree found in water gas, the size and number of burners in sleeping apartments might be limited, and means of ventilation insisted upon. The attention which has of late been called to deaths by the inhalation of gas has led inventors, with more or less success, towards the discovery of some automatic device for closing the pipe or burner, in case the light is blown out or by some accident the gas is turned on. Something of the kind might be desirable, especially in lodging rooms. These suggestions are made simply by way of illustration. Other and more effective provisions might be adopted. The Board is firmly of the opinion that the certificate as to safety ought to be omitted from the license. Such a certificate, it is confidently believed, will in no way serve to protect consumers. The Board respectfully suggests that it should have power to place such conditions in the license as in its judgment will tend to guard the community against accidents. The license should also be made revocable, or be subject to modification, as the most practical means of enforcing its provisions and speedily preventing any further danger which might be likely to arise.

For these reasons a change of the statute is urged upon the attention of the Legislature. The draft of a bill* embodying the views of the Commissioners, is submitted, and the passage of some such act is respectfully and strongly recommended.

At the stockholders' meeting of the Waltham (Mass.) Gas Light Company the following result was reached: Clerk and Treasurer, Geo. A. Stearns; Directors, Lowell Clark, John R. Farnum, Arthur T. Lyman, A. M. Goodale, Geo. A. Stearns, Wm. Roberts, and Augustus Flagg. The last two named take the places of M. H. Young and C. E. Getchell, resigned. The annual report of the Treasurer shows that the balance on hand, Jan. 1, 1889, was \$41,639.25, and the income for the year \$27,631.59, making a total of \$69,270.84. Out of this dividends to the amount of \$8,400 were paid, interest took \$1,022, insurance, \$388, and construction \$4,142, leaving a surplus on Jan. 1, 1890, of \$55,308.84. The income in 1888 was \$28,419.26, or \$787.67 more than in 1889. The Company now has 42 arc electric lights in use for the city, and 50 for commercial purposes, besides 61 incandescent 65-candle power lamps, and 565 of 40-candle power.

* For a copy of bill, see JOURNAL, ante, p. 206.

[OFFICIAL REPORT.—REVISED BY THE SECRETARY.]

TWENTIETH ANNUAL MEETING, NEW ENGLAND ASSOCIATION OF GAS ENGINEERS.

HELD AT YOUNG'S HOTEL, BOSTON, MASS., FEB. 19 and 20, 1890.

FIRST DAY—FEB. 19—MORNING SESSION.

The Twentieth Annual Meeting of the New England Association of Gas Engineers was held at Young's Hotel, Boston, Feb. 19 and 20, 1890, the President, Robert B. Taber, of New Bedford, Mass., in the chair.

The first session was called to order Wednesday, Feb. 19, at 10 A.M. The President announced that the Secretary, Mr. C. H. Nettleton, was necessarily absent, and, on motion of Mr. Stiness, Mr. C. J. Russell Humphreys was appointed Secretary *pro tem*.

COMMITTEE ON INVITATIONS.

The President—I will appoint Mr. Slater and Mr. Norton to serve as a committee to invite gentlemen who have done us the honor of being present, and who may be eligible to be with us, to join us; and also to invite anyone whom they may know to be in the city, and whose attendance might interest or benefit the Association, to meet with us.

Mr. Slater—I presume that "eligible to meet with us" means any gas man?

The President—I purposely put it in that way. Your own sense of their eligibility will determine whom you shall invite to join with us in our deliberations.

DISPOSING OF THE MINUTES.

The President—The first business in order will be the reading of the minutes of the last meeting.

Mr. Harbison—I move, as the minutes have been printed in the AMERICAN GAS LIGHT JOURNAL, that they stand approved as printed.

Mr. Stiness—I second that motion.

The motion was passed.

APPLICATIONS FOR AND ELECTION TO MEMBERSHIP.

The President—The next regular business will be the consideration of applications for membership. The Secretary has a list of those whose names have been scrutinized by the Board of Directors and approved by them.

The Secretary read the following list of applicants for membership, as approved by the Board of Directors:

Active Members.

A. C. Anthony, Providence, R. I.	E. J. Nutter, Milford, Mass.
Henry Boardman, Bangor, Me.	J. J. Nutter, Milford, Mass.
Andrew J. Horton, Brattleboro, Vt.	G. M. Rossman, Keene, N. H.
F. H. Lane, Wallingford, Conn.	L. A. Saville, Lexington, Mass.
H. M. Lane, Leominster, Mass.	Wm. H. Spaulding, Clinton, Mass.
F. W. Norton, Nashua, N. H.	

Associate Members.

Frank H. Brown, Waltham, Mass.	Wm. E. McKay, Boston, Mass.
Geo. C. Hicks, Boston, Mass.	Chas. E. Willard, Boston, Mass.
William Homes, Boston, Mass.	E. H. Woodward, Concord, N. H.

On motion of Mr. Harbison, Mr. Stiness was directed to cast the ballot of the Association for the election of the applicants named; and they were declared to be duly elected to membership. The new members were then introduced to the Association.

RESIGNATION OF MR. JAS. PORTER.

The Secretary having read a letter from Mr. James Porter, resigning membership in the Association, the President remarked that the Directors acted upon it last night, and approved it; but he thought it proper that it should be brought before the whole body.

LETTERS OF REGRET.

The President—We have several letters received from members of our own body, and from others who have been invited to attend this meeting, regretting their inability to attend. The Secretary will read the names, but I think we will not delay business by reading the letters.

The Secretary stated that letters of regret had been received from—

H. C. Adams,	T. J. Hayward,
Walton Clark,	Prof. E. G. Love,
C. A. Coffin,	John McIlhenny,
W. H. Denniston,	George S. Page,
Frederic Egner,	Geo. G. Ramsdell,
D. D. Flemming,	W. Cary Sanger,
G. A. Hyde, Jr.,	Robt. Young.

Mr. Stiness—I would like to ask if, in the reading of papers, we are to follow the printed programme. I suppose there are some members here

who feel more interest in some of the papers than they do in others; and as our country members do not get to Boston every day, I have no doubt they would be glad to know when certain papers are to be read, in order that they may be present to hear them.

The President—The announcement merely states that "during the meeting the following papers will be read." It was understood that Mr. Nettleton would give us some idea how he had arranged this matter; and in his absence the Directors at their meeting last evening thought they would select such times for reading the papers as the writers of the papers might prefer. For that reason I cannot now state the order in which the papers will be read; but if anyone having a desire to hear a certain paper will express it, and the writer can be found, the paper may be read at any time. There are certain of the papers which would naturally group themselves, and which should properly be read together, but no definite arrangement of that kind has been made. The Secretary will listen to suggestions from any member as to the order of reading, and I have no doubt the meeting will be glad to follow any desired order. The reading of Mr. Addick's paper has been deferred until to-morrow, as he is not prepared to read it to-day.

ROLL CALL.

Upon the call of the roll the following members answered to their names as being present:

Honorary Members.

Jos. R. Thomas, New York City. Col. Fred. S. Benson, Brooklyn, N. Y.
Eugene Vanderpool, Newark, N. J.

Active Members.

Addicks, W. R., Boston, Mass.	Learned, Waldo A., Newton, Mass.
Africa, W. G., Manchester, N. H.	Long, Robt. J., Salem, Mass.
Allyn, H. A., E. Cambridge, Mass.	Macmun, Geo. F., Natick, Mass.
Amory, Dr. R., Brookline, Mass.	Manchester, Geo. L., Easthampton, Mass.
Anderson, Wm., Marlboro, Mass.	Manchester, J. Howard, Bristol, R. I.
Andrew, John, Chelsea, Mass.	Moore, David, Salem, Mass.
Atwood, H. A., Plymouth, Mass.	Neal, G. B., Charlestown, Mass.
Badger, Wm., Concord, N. H.	Norton, H. A., Boston, Mass.
Bill, Geo. D., Malden, Mass.	Parker, Albert H., Bangor, Me.
Blood, F. C., Ware, Mass.	Prichard, Chas. F., Lynn, Mass.
Boynton, D., Chicopee, Mass.	Quinn, Andrew K., Newport, R. I.
Burnham, J. H., E. Boston, Mass.	Richardson, F. S., N. Adams, Mass.
Cabot, J., New York City.	Sherman, F. C., New Haven, Conn.
Coffin, J. A., Gloucester, Mass.	Slater, A. B., Providence, R. I.
Coggshall, H. F., Fitchburg, Mass.	Slater, A. B., Jr., Providence, R. I.
Cooper, A. F., Exeter, N. H.	Snow, Wm. H., Holyoke, Mass.
Copp, A. M., Boston, Mass.	Spaulding, C. F., Waltham, Mass.
Coyle, P., Charlestown, Mass.	Spaulding, C. S., Brookline, Mass.
Davis, F. R., Athol, Mass.	Spear, J. Z. A., Dorchester, Mass.
Fowler, S. J., Westfield, Mass.	Stedman, W. A., Rochester, N. Y.
Gerould, C. L., Brooklyn, N. Y.	Stiness, S. G., Pawtucket, R. I.
Gillmor, O., Norwich, Conn.	Taber, R. B., New Bedford, Mass.
Goodno, G. F., Dedham, Mass.	Tarbell, A. Willis, Waltham, Mass.
Greenough, M. S., Boston, Mass.	Tarbell, Wm., Waltham, Mass.
Harbison, J. P., Hartford, Conn.	Tilton, D. D., Newburyport, Mass.
Hassett, E. J., Beverly, Mass.	Todd, J. R., Middletown, N. Y.
Humphreys, C. J. R., Lawrence, Mass.	Wells, Levi W., Boston, Mass.
Jenks, Z. M., Woonsocket, R. I.	Wetherbee, G. E., Worcester, Mass.
Jewitt, M., Clinton, Mass.	Wood, Gideon, New Bedford, Mass.
Jones, E. C., Boston, Mass.	Wood, W. A., Dorchester, Mass.
Kelly, H. H., Greenfield, Mass.	Woodward, R., Waltham, Mass.
Lamson, C. D., Worcester, Mass.	Yorke, E. H., Brockton, Mass.
Leach, H. B., Taunton, Mass.	
Learned, E. C., N. Britain, Conn.	

Associate Members.

Coburn, Cyrus M., Chelsea, Mass.	Smith, Robt. R., N. Hartford, Conn.
Davis, Fred. J., Waltham, Mass.	Tufts, Nathaniel, Boston, Mass.
Gifford, N. W., N. Bedford, Mass.	Tobey, F. Jr., New Bedford, Mass.
Holmes, R. E., W. Winsted, Conn.	Waldo, Chas. S., Boston, Mass.

The Committee on Invitations announced that the following non-members would attend the sessions at the invitation of the Association:

Barker, F. E.	Daley, D. R.	Graeff, Jr., G. W.	Rowland, C. L.
Bush, J. S.	Dickey, C. H.	Howard, Gov. J. L.	Shelton, F. H.
Blodget, C. W.	Fowler, Jno.	Kreischer, G. F.	Sprague, F. R.
Corbett, C. H.	Fry, C. C.	Loomis, B.	Stanley, I. N.
Coggeshall, C. H.	Floyd, F. W.	McDonald, W.	Wood, A. C.
Coffin, A. B.	Goodwin, W. W.	Mooney, Wm.	White, Wm. H.
Down, W. H.	Gardner, Jr., J.	McGeorge, D. H.	Weber, O. B.

(To be continued.)

The Proposed Hatteras Light.

The proverbial dangers of Cape Hatteras, says the *Engineering Record*, are due not only to its exposed position on a much-traveled line of coastwise trade, but to the fact that very dangerous shoals extend from it several miles seaward, on which vessels might strike in bad weather before seeing the light on the Cape itself. Several whistling buoys placed on the shoal had been carried away, owing, as is supposed, to the links of their mooring chains having chafed through by incessant motion in the grinding sand, and with increasing commerce the loss and danger became so great that in January, 1883, many underwriters, merchants, owners and sea captains petitioned Congress for a lightship to be stationed at that point, which, in view of the fate of the buoys, the Light House Board did not consider wise, as if the lightship should get adrift on a lee shore her loss with all on board would be inevitable.

A lighted beacon, consisting of a skeleton iron tower, 40 or 50 feet high, with a reservoir for compressed gas, had already been suggested, and Major O. E. Babcock, U.S.A., Engineer of the Fifth Light-house District, was ordered to examine and report as to the feasibility of such a scheme. He, in July, 1883, reported the project feasible, though likely to be dangerous and expensive in execution; as, however, the preliminary work would be as expensive for a beacon as for a light-house, he advised the construction of the latter on an iron pier, built after the manner of those at Long Branch and Coney Island, the light-house itself to be of the same character and 80 to 100 feet high.

Nothing more seems to have been done for nearly two years, when, in June, 1885, plans and estimates for the proposed structure were obtained from SooySmith & Co., engineers and contractors, of New York city. They advised the use of an octagonal wooden caisson for the foundation, and estimated the cost of the entire structure at \$500,000. In January, 1888, Congress appropriated that sum for the construction of the light house with the important provision "that such contractors for doing this work may be selected by the Light-house Board, as may, in the judgment of the Board, be best fitted by reason of skill, experience, possession of plant and control of means to do the work." Bids have accordingly been invited for the complete construction, equipment and temporary maintenance of the proposed light-house, and will be received up to July 1, 1890.

The following extracts are taken from the specifications:

The locality is one of the most exposed on the coast. The site has about 24 feet of water over it at low tide; the rise and fall of the tides at the site is about $1\frac{1}{2}$ feet; the current velocity has been estimated at 4 knots per hour after heavy gales, and the surface of the shoal at and in the vicinity of the site is composed of fine gray sand with broken shells.

The tower is to be an inclosed structure, 150 feet high from low water mark to the focal plane of the lantern.

The foundation of the tower must be solid and massive to withstand the impact of the waves. Its base must be sunk to a stratum underlying the surface of the shoal which offers sufficient resistance to the weight of the structure; and should this stratum consist of material which can be scoured or displaced by the sea, it must be deep enough below the latter to be out of all possible reach of the destructive action of the water.

The site all around the structure is to be protected by a riprap packing, composed of granite blocks, weighing not less than 2 tons apiece. The slope line of the packing must intersect the foundation at low water mark and the original surface of the site at a distance of 40 feet from the structure.

The first floor of the structure is to be at least 30 feet above high water mark. The choice of the various kinds of material to be used in the construction of the tower is to be left to the designer and the contractor.

The probable construction will be that of an immense wooden caisson with a tapering iron tube projecting upwards from its center. This will be built at some convenient port and towed out to its site, being lifted on the way over a bar where there is but 8 feet of water at high tide. When the site is reached it will be rapidly sunk until the cutting edges enter the sand, when the water will be forced out by compressed air and the bottom excavated from within until the desired depth is reached, when the entire caisson and the tube up to 30 feet above high water will be filled solid full of concrete. Above this will rise an iron or steel tower having 10 stories, including the watch room and lantern.

The contractor must fix the time at which he will have the work completed, and must commence work within one month after the contract has been awarded. When the light-house is finished he must completely equip it and keep it in satisfactory operation for one year before any of the work is to be paid for.

The Hatteras Light, when completed, will be one of the most important and difficult pieces of light-house work ever executed, the only

structures comparable to it being the Rothersand Light-house on the coast of Holland and that on Fourteen Foot Bank in Delaware Bay.

Preventing the Incrustation of Boilers.

Walter Chambers, in an article on this subject, says that although much has already been written upon the management and care of steam boilers, and many expedients proposed for removal of incrustation, more might advantageously be said about the benefits to be gained by a wider recognition of those means for promoting economy by preventing incrustation and its attendant waste of fuel. It is estimated that 1-16 inch of scale causes a loss of 13 per cent. of fuel; $\frac{1}{4}$ inch, 38 per cent., and $\frac{1}{2}$ inch as much as 60 per cent., besides predisposing the boiler to explosion as well as incurring the loss of time and labor for its removal.

Many of the misnamed and anti-incrustators contribute to the evil, as they contain organic matter, and help rather than hinder incrustation, while those that are effective in water containing carbonates of lime frequently liberate pyroligneous acid that adversely affects the iron; then the alkaloids, when used in excess, conduce to foaming, and, in conjunction with the oil from the engines, they saponify or form soap.

The presence of damp air is prejudicial to the interior of a boiler, as the process of oxidation or corrosion is thereby accelerated; when we reflect that the feed pump is commonly made about twice the capacity required for the feed water, it is obvious that a considerable amount of air, and consequent deterioration of the boiler, is thus accounted for. A remedy is easily found in a self-adjusting pump, the duty of which could be controlled by means of a float, so that it would deliver the requisite amount of solid feed water without air. A thorough system of economy and efficiency would comprise a surface condenser for returning the pure water obtained from condensation of the exhaust steam from the engine, together with a small evaporator heated by the waste chimney gases, for making up any loss of pure water due to leakage of steam. These are simple and now well recognized contrivances, and a comparatively small outlay in this direction would prevent the many evils due to incrustation and should lessen the premium of insurance and effect a saving in expenditure.

Boilers are subject to the chance of damage when safety valves or pressure gauges are out of order. Not a day should pass without ascertaining that the former are in operation, while the index of the gauge should, if correct, stand at zero when the steam is off, and also show the same pressure as the safety when it blows off, so its accuracy is readily ascertained.

The level of water in the boiler should be verified at regular intervals by means of the gauge cocks fitted for that purpose, quite independently of the gauge glass; all these require frequent blowing to ensure safety, since we learn that the majority of serious explosions are due to shortness of water. The benefits of using hot feed water have already been referred to, and in no case should cold water be pumped into a hot boiler, as local contractions, leaky seams and joints, and even ruptures may be occasioned, while for similar reasons cold air currents should also, as far as possible, be excluded from the furnaces and flues.

Boilers also suffer, to a considerable extent, from the lubricants from the engine that find their way in with the feed water. Many of them are deleterious to a degree, and have doubtless contributed to many adverse occurrences. Perhaps there is no detail deserving of more attention than that of selecting suitable lubricants. Their influence upon the economy of the boiler will be more apparent when referring to efficient lubrication in its relation to the durability of machinery.

The Connellsville Coke Trade.

A local authority writes that the coke trade of the Connellsville region for 1889 beats the record from 15 to 20 per cent., and is altogether immense. But, big as it was, the record for 1890 will, unless all signs fail, not only equal, but surpass it. With such a comforting assurance for the future, we may contemplate the past with some degree of complaisance. During the year just ended the Connellsville coke operators marketed 326,220 cars of coke, aggregating 5,825,000 tons. A large portion of this immense output, the greatest output in the history of the greatest coal region in the world, was sold at prices near the dollar mark, yet the average price of the total output was about \$1.40 per ton, at which rate the spot value of the yearly output would be about \$8,150,000. The output for 1888 was in round numbers 5,000,000 tons, of the average value of \$1.20, making a total value of \$6,000,000. These figures show a decided increase in trade during the past year, in spite of the very dull manner in which it opened. The beginning of 1889, it will be remembered, ushered in a declining coke trade, which continued into Februa-

ry, when production and shipments were 25 per cent. below January figures. Production was therefore restricted both by allowing ovens to grow cold and by ordering lay-off days. The demand increased somewhat in June, but the Johnstown disaster retarded eastern shipments considerably. The July output rose to the January average, but the August strike cut it down again to the February figures. Since then it has been hovering between 500,000 and 600,000 tons per month.

The following is a statement of the estimated tonnage for 1889, condensed from the weekly reports collected by the *Courier*:

January.....	524,447
February....	417,280
March.....	433,090
April.....	418,534
May.....	454,250
June.....	421,178
July.....	497,115
August.....	415,254
September.....	513,190
October.....	600,624
November.....	537,645
December.....	593,219
Total.....	5,825,826

The shipments for 1889 show a grand total of 326,220 cars, an average of 1,046 cars per day for every working day in the year. Following is a comparative statement from the *Courier* files, showing the shipments during 1888 and 1889, with the daily averages appended:

1888.	Pitts.	West.	East.	Total.	Av.
January.....	4,125	13,600	2,500	20,225	778
February....	3,500	10,500	4,500	18,500	740
March.....	2,625	12,000	4,000	18,625	680
April.....	2,000	12,600	5,600	20,200	808
May.....	4,300	13,800	6,700	24,800	919
June.....	4,900	9,460	4,800	19,160	766
July.....	4,000	10,700	5,860	20,560	790
August.....	5,350	12,450	6,650	24,450	905
September...	5,270	13,916	6,140	25,326	1,013
October.....	5,900	17,900	5,925	29,725	1,100
November...	6,325	17,685	6,060	30,070	1,156
December....	6,800	17,900	6,100	30,800	1,174
Totals....	55,095	162,511	64,835	282,441	905
1889.	Pitts.	West.	East.	Total.	Av.
January.....	6,650	16,125	5,640	28,415	1,052
February....	5,300	12,700	4,725	22,725	947
March.....	5,713	14,437	5,426	25,576	984
April.....	5,356	13,736	5,881	24,773	951
May.....	5,375	15,130	6,042	26,567	984
June.....	6,090	15,059	4,350	25,499	1,020
July.....	6,154	15,910	6,304	38,368	1,050
August.....	5,560	12,240	4,037	21,837	808
September...	5,815	16,155	5,284	27,254	1,090
October.....	7,325	16,550	6,180	30,055	1,113
November...	6,640	18,659	6,152	31,451	1,210
December....	6,800	20,300	6,600	33,700	1,348
Totals...	72,778	187,021	66,421	326,220	1,046

The prices for coke for 1889, like those of 1888, ran the gamut from \$1 or less to \$1.75 or more. The operators started out in 1888 by dropping the figure from \$2, to which coke had gotten during the latter part of 1887. Within three months it was down to the dollar mark. The two concluding months of the year saw a big demand and a modest advance in price to \$1.25. This figure held good for the first three months of 1889, in spite of a declining demand, but April 1 saw a slumpy market, and in a few short weeks dollar coke again ruled. During the midsummer it was hard to get 90 cents for it. In August the workmen took the bull by the horns by demanding an advance in wages equivalent to 12 per cent. They enforced it by a successful strike and prices perforce went up from \$1.35 to \$1.50. A booming trade set in and sustained this rather radical advance. November and December coke sold for \$1.75, with special orders as high as \$1.90 to \$2. A determined move was made to put the price to \$2 with the beginning of the present year, but more conservative counsels prevailed.

The following table gives the prices of coke for the last six years, on board the cars at ovens, per ton of 2,000 pounds:

Month.	1884.	1885.	1886.	1887.	1888.	1889.
January..	\$1.00	\$1.10	\$1.20	\$1.50	\$1.75	\$1.25
February.	1.00	1.10	1.35	2.00	1.75	1.25
March....	1.00	1.10	1.35	2.00	1.50	1.25
April.....	1.10	1.20	1.35	2.00	1.00	1.15
May.....	1.10	1.20	1.50	2.00	1.00	1.10
June.....	1.10	1.20	1.50	2.00	1.00	1.10
July.....	1.00	1.20	1.50	2.00	1.00	1.00
August...	1.10	1.20	1.50	2.00	1.00	1.00
September	1.10	1.20	1.50	2.00	1.00	1.35
October...	1.10	1.20	1.50	2.00	1.00	1.50
November	1.10	1.20	1.50	2.00	1.25	1.75
December.	1.10	1.20	1.50	2.00	1.25	1.75

Among the notable features of the coke trade of 1889, aside from those already touched upon, two stand out in bold relief, namely, the ear famine that was and the coke king that is. As soon as the fall trade began to boom and the operators knew once more what it was to have orders to their full capacity, the railroads betrayed an inability to handle all the traffic. Both cars and motive power seemed inadequate. Some of the larger operators, despairing of a remedy, bought large numbers of individual ears. These, together with the cars furnished by the railroads, last month, for the first time, were able to meet the demands made upon them.

During the year the H. C. Friek Coke Company succeeded in purchasing controlling interests in a number of ovens, buying several of their largest competitors outright. Their holdings now cover about two-thirds of the region. They made their principal purchases during the summer, when trade was dull, with prices nearer 90 cents than \$1. The year has also been marked by considerable activity in the oven building line. As a consequence the total number of completed ovens in the region has increased from 13,975 to 14,458.

Profit in Gas Making.

The half-yearly report of the Directors of the London Gas Light and Coke Company, for the six months ended December 31, 1889, seems to us to show that there is good profit in selling gas cheaply. We make the following extracts from the report:

The accounts for the half-year ending the 31st of December last show that, after providing for interest and preference dividends, a balance of £574,785 remains, out of which the Directors recommend the statutory dividend on the ordinary stock of the Company at the rate of 13 $\frac{1}{4}$ per cent. per annum.

The half year just passed has been remarkable for a substantial increase in the quantity of gas sold, which amounts to nearly 5 $\frac{1}{2}$ per cent. over the quantity sold in the corresponding period of 1888. This result is mainly due to the rapidly extending use of appliances for cooking and heating by gas, and, in a lesser degree, to the improvement in the lighting business brought about by natural expansion and by the undoubtedly prosperous condition of general business. The great number of cooking and heating stoves sold and fixed by the Company during the past six months, leaves no doubt in the minds of the Directors that the use of gas for fuel is being very largely developed.

In order to meet the requirements of the public for a more extensive supply of gas, it will be necessary to increase the manufacturing plant at some of the Company's stations, and also to add to the storage and distributing plant by the erection of additional gasholders. For these purposes an issue of new capital will shortly be necessary, of which due notice will be given to the proprietors.

The favorable condition of the trade of the country, while exercising a beneficial effect upon the Company's business, has, on the other hand, greatly augmented the price of materials used in construction and of coal for carbonizing. The rise in the price of iron, fire goods, and stores generally is very considerable; and this increased cost of material, coupled with the very large addition which has been made to the expenditure of the Company in wages (amounting to about £150,000 per annum), will cause a heavy addition to the charges on revenue, and tend to retard the further decrease in the price of gas. The extent to which the balance of profit may be adversely affected will, in a great measure, be governed by the increase which may be looked for in the sale of gas, together with improved prices of coke and other residuals.

With regard to the supply of coal, the contracts, at favorable prices, under which the Company is working have yet about six months to run. Proposals for the extension of some of them for further periods, with a re-arrangement of price, are under the consideration of the Directors.

The Company has, so far, been free from the labor troubles and

complications which have lately occupied so large a portion of public attention, and which resulted in the crisis in Manchester and South London. The new arrangements of eight-hour shifts, and other modification of working hours and rates of pay, which were agreed upon in the spring with the Company's workmen, have, in spite of such minor difficulties as are incident to novel conditions of manufacture, worked fairly well. The Company has strictly adhered to its engagement with the men, who, on their side, have, on the whole, responded in the same spirit. The Company has abstained from in any way interfering with the organizations of its men, and has endeavored to meet any differences which have arisen in an equitable and conciliatory spirit. The Directors placed no credence in the rumors which became current that their men would throw up their employment for the purpose of bringing pressure to bear in a dispute in which this Company was not immediately concerned; but they did not neglect precautions to meet such a state of affairs had it unfortunately come about.

During the autumn, the Company's Engineer-in-Chief visited the United States of America, with the view of investigating the methods of gas manufacture in the large cities there, more particularly in reference to the various systems of lighting by water gas. The result of his examination led him to the conclusion (in which the Directors concur) that, while enriched water gas for lighting and heating is not likely, in this country, to replace coal gas, it may be found useful to provide for the manufacture of water gas, to be used in addition to, and in conjunction with coal gas on occasions when a large quantity of gas is required to meet a sudden demand. The Directors have inaugurated some experiments for testing, in a practical manner, the feasibility of thus supplementing their manufacturing plant, as well as of other suggested methods of improving the carbonizing of coal and the dealing with residuals.

The judgment of the House of Lords, given on the 9th of August last, in the Nine Elms case, between the Gaslight and Coke Company and the South Metropolitan Gas Company, was in favor of this Company—reversing the two previous adverse judgments in the Courts below. The decision, carrying costs, was unanimous, and protected this Company on all points. A perpetual injunction was granted against the supply of gas by the defendant Company for consumption outside the limits of its own district, and damages, the amount of which is now being ascertained, were awarded to this Company. The Directors attach great importance to this judgment of the final Court, as it confirms the inviolability of the Company's district, as settled by the Act of 1860.

The question of simplifying and improving the method of the official testing of gas for illuminating power and purity has made further progress; and the Directors hope that the public authorities and the Company may be able to agree upon a basis for the legislation necessary for its settlement.

Nothing has occurred since the issue of the last report to alter the opinion of the Directors that the progress of electric lighting will not produce any injurious effect upon the business of the Company.

After a half year full of interest, and not free from anxiety, the Directors look forward with confidence to the continued prosperity of the Company, which, however, can only be secured and shared in by proprietors and employes through the cordial co-operation of all connected with the Company in making its working economical and successful in all its branches.

Tinting Incandescent Lamp Bulbs.

Mr. Arthur S. Huey, of Minneapolis, proposes the following method of treating incandescent lamp bulbs: Prepare the glass by thoroughly washing in soap and water and drying. Then dip in bath (made by beating up the whites of two eggs in one and a half pounds or pints of water, and filtering) and hang up to dry. Dissolve the aniline color in photographer's common collodion. Red or blue aniline will form clear solutions, while the green solution will require filtering. Yellow aniline forms a handsome color, but the surface of the glass presents a frosted appearance after the application. Violet and purple colors may be obtained by combining red and blue in different quantities. When the solution is ready, dip the prepared glass bulbs therein, hang up to dry, and finally pass a current through the bulb for half an hour, that the heat thus generated may harden the coating of the collodion, or place in a current of air. The preparation can easily be removed with alcohol or sulphuric ether, but is not affected by water. Experience has shown that the best results are obtained by not using too much aniline. Make the color light rather than deep, and apply two or three coats.

ITEMS OF INTEREST FROM VARIOUS LOCALITIES.

SOME time ago we noted that the authorities of Downingtown, Pa., had appointed a committee to negotiate with the owners of the local gas plant, the same to be operated thereafter on municipal account, and that the owners were not averse to parting with their property. While the closing details were being arranged, some of the residents rather unaccountably raised objection, the result of which was that the proprietors of the Gas Company withdrew their offer to sell.

THE town of Centralia, Wash., is to light its streets by electricity, the authorities having granted a franchise to a Company, the proprietors of which are to have an exclusive right for 25 years to distribute electric currents in Centralia. The public lighting contract calls for the maintenance of 10 arcs (2,000-candle power), to be paid for at the rate of \$12 each per month, on a midnight table, the rate to be increased to \$15 per month in case it is determined to run the light until 3 A.M. The rates to ordinary users (on the basis of a 16-candle power incandescent lamp) have been adjusted to the following: To run until 9.30 P.M., \$1.25 per lamp per month; until midnight, \$1.50; all night, \$2.00.

THE reduced gas rates for Steubenville, O., are to take effect on April 1st. Even at the risk of duplicating the information, we give the new schedule:

Monthly Consumption.	Net Rate per 1,000.
Under 5,000 cu. ft.	\$1.50
Over 5,000 cu. ft., but under 10,000	1.35
Over 10,000 cu. ft.	1.20

This is reasonable enough, and speaks well for the Company's liberality.

FROM a Philadelphia source we learn that complaint is loud in some sections of the city about the defective condition of many of the gas services. Chief Engineer Park explains this by saying that the defective pipes pass through soils that are very destructive to iron.

SOME time ago we noted that the Boston Electric Company had instituted suit for patent infringement against Charles W. Holtzer and the Holtzer-Cabot Electric Company. The defendants are charged with infringing letters patent No. 250,590, granted July 27, 1880, to Jacob R. Tirrell, and letters patent No. 281,345, issued July 17, 1883, to Chas. H. Crockett, both relating to improvements in electric gas lighting apparatus. The important feature in the Tirrell invention is turning the gas cock by a single electric impulse. Though the complainants' experts differ as to this, yet upon the affidavits the court holds that the defendant's contention is correct. The issue is then narrowed down to this, whether the court should enjoin the defendants against the use of a burner so constructed that the gas cock is opened by a series of electric impulses, when the claim of the Tirrell patent makes the turning of the gas cocks by a single impulse, one of the most important elements on a motion for an injunction, *pendente lite*, where the mind of the court must be satisfied on the subject of infringement, an injunction should not be granted under these circumstances. As to the Crockett patent, the court was inclined to the opinion that it must be limited to the form of the devices therein described, or what is clearly equivalent. The device for opening the gas cock, and especially the ratchet and pawl, which are found in the defendant's burner, should not be considered the equivalent of the projections at the end of the valve and the opening devices described by Crockett. The defendants' burner, therefore, does not infringe, or at least there is so much doubt of it that no injunction should issue.

AS was predicted in the JOURNAL about a fortnight ago, the plant and franchises of the Batavia (N. Y.) Gas Light Company have gone into new hands. The purchaser, however, was the local Consumers Electric Light and Power Company, whose proprietors will now consolidate the hitherto conflicting interests. The officials of the Consolidated Company have been named as follows: President, S. D. Purdy; Secretary and Treasurer, Chas. H. Caldwell. The capital stock in the enterprise is about \$100,000, and a considerable sum will be expended in betterments to the gas plant.

THE Committee on Manufactures, Massachusetts Legislature, has voted unanimously against the proposition that gas companies in that State should be prohibited from declaring dividends in excess of 10 per cent. per annum.

AT the annual meeting of the Natick (Mass.) Gas Company the following officers were elected: President, Riley Pebbles; Secretary and Treasurer, Edward Clark; Directors, Riley Pebbles, Edward Clark, Harrison Harwood, John O. Wilson and L. Winch.

ON the 6th inst. the Superintendent of the Napa (Cal.) Electric Light Company was ordered to close down the works until further notice. This abrupt decision discomfited the users of incandescent lamps, and the consumers were not greatly mollified when told that the plant was shut down "because it needed repairs." In all probability the supply of electric light currents is not a profitable business at Napa.

AT the annual meeting of the Portsmouth (N. H.) Gas Light Company the following choice of officers was made: President, John Sise; Clerk and Treasurer, Frank J. Philbrick; Directors, John Sise, Marcellus Eldredge, W. W. Cotton, Edward S. Fay and H. W. W. Jackson.

SUPT. TRACY, of the Poughkeepsie (N. Y.) Gas Company, says that the use of gas for fuel purposes in that city is spreading with amazing rapidity.

AN important change (see advertisement of Company, page 267) has occurred in the management of the Westinghouse Machine Company's St. Louis District Agency.

PROF. RICHARD T. ELY, of the Johns Hopkins University, of Baltimore, Md., has again turned his attention to gas matters, having delivered (Feb. 13) the second of his two lectures on "Taxation." He spoke before a large audience in the Peabody Institute, and a summary of his speech is appended:

The results of our inquiry into taxation thus far have given us results which may be formulated under these five heads.

1. Taxes have brought us representative government, and they tend to grow with the growth of free institutions.
2. Taxes are not payments for services rendered by governments but a taking by the nation of that to which it is entitled.
3. The amount to which the nation (State or city) is entitled can only be determined by the conscience and intelligence of the community.
4. Taxation is being used, and will be used to greater extent hereafter, as an agency for social reform.
5. Other sources of income than taxation must be found in governmental pursuits.

Our situation is briefly thus: The expenditures of government have increased with enormous rapidity in recent times, and there is every reason to anticipate that they will continue to increase in the future. The man who has looked only a little way into this subject is tempted to say: If we reform government by means of good civil service and by other devices, we can introduce retrenchment into practical administration. Unfortunately for this theory—for it is pure theory—governmental expenses have increased most rapidly where administration is purest. An inevitable effect of better government in Baltimore or Maryland would be to increase, not decrease, public expenditures. On the other hand, the difficulties in the assessment and collection of taxes increase rapidly after a certain point is reached. In a city like Baltimore we need twice as much to spend to give us what as a city we need; yet it is evident that our tax rate is already too high. We must, then, if we would keep pace with the world's progress, turn to industrial pursuits for a portion of our public revenues.

Those industrial pursuits which are best adapted to furnish us with revenues are called natural monopolies; and by this we mean that their own inherent properties make them monopolies. There are several important industries which are of this character, but the gas business illustrates them all—perhaps better than any other—because the general principles are in this business so clearly seen. There are those who would have us still believe that competition in the gas business is possible; but surely they are the wildest kind of theorists. What is a theory worth that has not facts back of it? Now, all that I ask is for those who believe that competition in the gas business is a possibility to adduce a single instance of permanent successful competition. Let them dispense with vague generalities and give us facts. Competition has been tried thousands of times, and I defy them to produce the single instance of successful competition. I restrict them to no country and to no clime. They may travel north or south, east or west; they may search Europe, Asia, America; but they will look in vain for successful competition in the gas business. Let us be content with the unvarying testimony of hard facts. Now, there are two ways in which revenue may be derived from natural monopolies. Private parties may pay for the monopolies, or government itself may undertake to operate them. The first method is better than the pursuit of such a Utopia as competition. If people are not willing to consent to public administration, then let private parties pay for monopolistic privileges their full value. These should, however, always be granted for a limited period only,

and the right of purchase without payment for franchise reserved. No perpetual franchises should ever be granted. No one is wise enough to say what may be desirable in the future, and the reserved right of purchase of plants of monopolies makes it possible for the nation, state, or city, to adjust itself to existing conditions. Direct administration by government is, however, preferable. In this case profits accrue to the public, and politics are purified. The following table compares the cost per night of electric lighting in five cities under private management and under municipal ownership of electric lighting plant:

	Private.	City.
Bay City, Mich.....	27.5 cts.	16.0 cts.
Painesville, Ohio.....	19.7 "	10.6 "
Huntingdon, Ind.....	39.0 "	13.7 "
Lewiston, Me.....	50.0 "	14.0 "
Aurora, Ill.....	89.5 "	15.0 "
Average per night.....	45.1 cts.	13.9 cts.

AT the last regular monthly meeting of the Directors of the Port Hope (Canada) Gas Company Mayor Burnham resigned his dual seat, as he now is, by virtue of his Mayoralty position, a Director as representative of the stock in the Company owned by the town. Mr. James Craick was selected by the Directors to fill the vacancy thus created.

THE Board of Aldermen, Hartford, Conn., have decided to equip a testing room for the gas inspector.

THE works of the Freeport (Pa) Gas Company will be closed down on or about April 1. The plant is worn out, and the prospects do not justify any expenditure on renewal account.

THE plant of the Fayetteville (N. C.) Gas Company has been materially added to. The rosin process of gas making has also been abandoned there, and a local coal is carbonized, which is obtained from Egypt, a village in Yancey county.

AT the annual meeting of the Jefferson City (Mo.) Gas and Electric Light Company it was resolved to keep the street lights burning all night during the time of the State re-union of the G. A. R. The Company also offered to furnish gas to the encampment without making any charge therefor. The officers chosen were: President, W. W. Wagner; Vice-President, Louis Schmidt; Secretary, Treasurer, and Superintendent, Charles E. Hess; Directors, W. W. Wagner, H. C. Geisberg, Louis Schmidt, C. E. Hess, and J. C. Fisher.

THE rates charged by the Rockville (Conn.) Gas and Electric Light Company for each 1,200-candle power commercial arc light are: One lamp, from dusk until 10 o'clock, on 4 nights of each week, 24 cents per night; two lamps, 22 cents; three lamps, 20 cents. From dusk until 6 o'clock, Tuesday and Thursday evenings, and later than 10 o'clock P.M., at the rate of 5 cents per hour.

A REPORTER of the St. Louis *Republic* (dated the 11th inst.) is responsible for the following: "St. Louis is destined to be the first city in the country to try fuel gas on a commercial scale. The experiment—for such it will be, though believed to be perfectly certain to succeed—will be made in a few months. Of the details, President McMillin, of the Laclede Gas Company, said yesterday: "Yes, we propose to put fuel gas on the market in a short time, say somewhere about the 1st of June or July. We are fortunately situated for the experiment. We have the water gas plant, which, as it is merely a duplication of the Laclede plant, so far as it goes, is superfluous for the making of illuminating gas, but can be utilized without any important changes for the making of fuel gas and its distribution over the territory covered by the water gas mains. Thus we can save possibly \$1,000,000 in the erection of a plant and the laying of pipes. Everything is ready to our hand. It will not take long to find out whether or not we can afford to keep up the making of the gas. Scientifically and mechanically the making of fuel gas is all right. We are certain of our standing; but as to its commercial success we do not yet know. Of course, it is only a question of time—gas is bound to be the fuel of the future; but whether people are now ready to take it in sufficient quantities to warrant us in making it is another thing. We shall sell it at 40 cents a thousand feet. It will cost us, say, 20 cents. That is a profit of 100 per cent. But it is only a profit of 20 cents a thousand feet, after all, and it will take a great many sales at that figure to pay profit on the \$1,000,000 or so invested. We shall need a great many consumers, and as it will be a new thing, we cannot be sure that people will take hold of it with sufficient promptness to make it an immediate success. But if we get enough consumers to

warrant it, we shall extend the pipes over the entire city. That will involve an expenditure of a good many million dollars; so, you see, we shall want to adopt Davy Crockett's motto and be sure we are right before we go ahead."

"How many consumers can you get along the line of the water gas pipes?"

"With our customers and those of the water gas company there are probably from 6,500 to 7,000 consumers along the lines of those pipes. If we got one-half of those we should feel encouraged to go ahead. We should canvass for customers, beginning on the outside of that territory, and as fast as we got enough to justify it, would extend the pipes. In that territory are many houses and offices heated by steam, and those we should not expect to get. But in the residence portion of the city we should be able to get many customers. Of course, many people will be only too glad to get fuel gas. But we expect to introduce it slowly. There are from 80,000 to 100,000 houses in St. Louis, yet there are only about 20,000 consumers of illuminating gas in the place, which will probably be a surprise to most people."

"How will the consumption of fuel gas compare with that of illuminating gas as to volume?"

"It will be larger, say from one-third to one-half more will be required in a stove, for instance, because it will not be as rich gas; that is, it will require more of it to give the same heat. That would bring up the price, say, to 60 cents per 1,000 feet, less than half what is now paid, so that consumers could afford to use it lavishly, if necessary."

"Will you use the same quality of coal in making fuel gas that is used in making illuminating quality?"

"No; we shall use, we expect, an Illinois coal that will be entirely used up, not even tar remaining as a residuum."

"You have faith in the fuel gas idea?"

"The greatest faith possible. As I said, there remains now only the question of getting enough customers to make the manufacture profitable—and that will come sooner or later. I am glad that St. Louis is to be the first place to try it on. There is one town—Jackson, Mich.—where they use fuel gas, but that is too small to determine the question of practicability one way or the other. The first experiment of a sufficient commercial scale will be made right here in St. Louis."

THE annual meeting of the stockholders of the New York and Cleveland Gas Coal Company was held in Pittsburgh, about a fortnight ago, when the following Directors were elected: W. P. De Armit, Henry Phipps, Jr., W. H. Berger, Frank Semple, John Walker, J. E. Umbstaetter, J. B. Hamilton, J. T. Colvin, and J. J. Donnell. The officers elected were W. P. DeArmit, President; Frank Semple, Treasurer; and C. L. Dixon, Secretary. In speaking of the years' business, Mr. De Armit said: "The last year has been so unsatisfactory and unprofitable that we are ashamed to have the figures published. The only cause for congratulation is in the fact that we are no worse off than our neighbors, in fact in better shape than some, and the only remedy I know of is to trust to the future to give us better prices for our product and a greater demand for coal." Another stockholder said: "The past year's business was much below that of the year before and we were far from satisfied with the past, and have little to encourage us in the future. As long as natural gas continues to be in such general use and the prices of it continue as they are, there is nothing in the coal business. We have not decided what will be done, but our Board of Directors will no doubt decide on what is best."

HENRY F. MARTIN, chemist to the Board of Health, recently entered complaint in the Court of Special Sessions against Mr. Jas. W. Smith, President, and Frederick Crowell, Superintendent, of the Consolidated Gas Company of this city. Defendants were charged with violating a section of the Sanitary Code, in that they permitted a nuisance to exist. From the station at Forty-fourth street and Eleventh avenue a number of pipes run into the bed of the North River, the pipes acting as carriers of refuse from the works to the river. It was claimed that the stench arising from the matter so deposited endangered the health of people obliged to reside within the affected district, hence Martin's complaint. No defence was interposed, and the Company was fined \$250.

BUFFALO, N. Y., pays its Gas Inspector, who is appointed for one year by the City Engineer, at a salary of \$1,000, and the passages in the city ordinances defining his duties are as follows:

Section 5—He shall have supervision over the public lamps and of lighting, cleaning, repairing and extinguishing the same; he shall see that they are kept clean and in good order, and at all times provided with good and sufficient burners of the capacity mentioned in the con-

tract between the city of Buffalo and the gas companies from which it purchases gas, and that such burners are kept free and clean, and pass the amount of gas called for in said contracts; and for that purpose he shall, as often as once every month, make a test of each and every one of such burners with some standard purchased by said city and report the result of such test to the Common Council. He shall daily make a photometrical test of the illuminating power of the gas and make weekly reports thereof to the Common Council.

Section 6—He shall have power and it shall be his duty, to enter every public building owned by the city, to test the meters therein and regulate and control the use of gas in each of said buildings. He shall at the end of each month, examine the meters in each of the public buildings owned by the city, make a record of the number of feet of gas consumed in each of said buildings, and report the same to the Common Council. He shall compare the same with the bills for gas furnished by the different gas companies and no such bill shall be paid until the same shall be certified by the gas inspector.

Section 7.—He shall see that the lamps are kept lit during the whole number of hours specified in the contracts between the city and the gas companies. He shall at the end of each month report to the Comptroller the number of lamps not lit during the current month and the number of hours they were not lit. It shall be the duty of the Comptroller to estimate the amount thereof, and deduct such amount from the estimate of gas furnished the city under its contract.

Surely, if Buffalo's Gas Inspector faithfully carries out these instructions, he may be said to earn his salary.

IN our reference to electric lighting rates at Rockville, Conn., it might also have been said that the contract between the Company and the authorities calls for the maintenance of 74 arcs (1,200 candle power) to be lighted on 300 nights in the year, and to be paid for at the rate of \$75 per lamp per annum.

THERE is talk of a gas works for Rapid City, South Dakota.

THE bill regulating the purity of Rhode Island gas, now before the General Assembly of that State, provides that no gas company shall supply in any city or town of the State gas which contains more than 20 grains of sulphur or 10 grains of ammonia per 100 cubic feet of gas, or more than 10 per cent. of carbonic oxide, or any sulphureted hydrogen.

THE annual meeting of the Salem (Mass.) Gas Light Company was notable for its surprises, foremost among which was the refusal of Mr. Wm. H. Jelly, who had been President of the Company for the past 17 years, to accept a re-election. Then an entirely new Board of Directors was chosen in the persons of John W. Leighton, of Boston, John R. Langmaid, H. A. Hale and Edwin Dodge, of Salem, and Geo. F. Sawyer, of Peabody. Mr. David Moore was re-elected Treasurer, and B. W. Sherman was named to succeed himself as Clerk. It is understood that the new management will advocate the operation of an electric lighting plant by the Gas Company, and the change in the Directorate was probably occasioned by a difference of opinion among the shareholders respecting the good policy of such a move. The sendout last year was 44 millions cubic feet, and a good round sum was expended in plant betterment during the twelvemonth.

MONTAGUE HAWK has been appointed meter inspector for the Easton (Pa.) Gas Company, vice Louis Pittenger, resigned.

THE proprietors of the incandescent electric supply of Martinsburg, W. Va., are endeavoring to secure customers on the following basis—the Edison system is used and the lighting value of the lamps is put at 12 candles: For the first light, 75 cents per month; 2d light, 65 cents; 3d light, 50 cents; 4th light, 40 cents; 5th light, 35 cents; 6th and all additional lights, 20 cents. They also offer shopkeepers on the main street, 10 lights for a payment of \$3.80 per month, said lights to be burned according to the user's convenience. That Company ought to be in the sheriff's charge before it is much older.

THE Lawrence (Mass.) Gas Company has chosen the following Board of Directors: Geo. L. Davis, Geo. D. Cabot, Chas. A. De Courcey, Chas. M. Seaver, N. H. Emmons, Benjamin Brewster and J. Lewis Stackpole.

THE City Clerk of San Jose, Cal., has been directed to advertise for plans, specifications and bids for lighting the streets of that city with electric lights for a term of 5 years, or less, as the Mayor and Common Council may determine. The successful bidder shall have its machinery and plant erected and in working order at least one month prior to the 30th of September next, the time at which the present contract for lighting the streets expires. The bond required is \$5,000.

Gas Stocks.

Quotations by Geo. W. Close, Broker and Dealer in Gas Stocks.

16 WALL ST., NEW YORK CITY.

FEBRUARY 24.

All communications will receive particular attention.
The following quotations are based on the par value of \$100 per share.

	Capital.	Pa.	Bid	Asked
Consolidated.....	\$35,430,000	100	96	—
Central.....	500,000	50	—	—
“ Scrip.....	220,000	—	—	—
Equitable.....	4,000,000	100	119	122
“ Bonds.....	1,000,000	—	113	115
Harlem, Bonds.....	170,000	—	—	—
Metropolitan, Bonds....	658,000	—	116	118
Mutual.....	3,500,000	100	109	—
“ Bonds.....	1,500,000	—	100	102
Municipal, Bonds.....	750,000	—	—	—
Northern.....	—	50	—	—
“ Bonds.....	150,000	—	—	100
Standard Gas Co --				
Common Stock.....	5,000,000	100	42	46
Preferred.....	5,000,000	100	83	86
Yonkers.....	—	50	112	—
Richmond Co., S. I....	346,000	50	—	—
“ Bonds.....	20,000	—	—	—
Gas Co's of Brooklyn.				
Brooklyn.....	2,000,000	25	109	111
Citizens.....	1,200,000	20	68	70
“ S. F. Bonds... ..	320,000	1000	100	103
Fulton Municipal.....	3,000,000	100	121	124
“ Bonds.....	300,000	100	1	5
Peoples.....	1,000,000	10	80	82
“ Bonds (5's).....	368,000	—	100	—
“ “ (6's).....	94,000	—	100	—
Metropolitan.....	1,000,000	100	93	96
Nassau.....	1,000,000	25	115	—
“ Cfts.....	700,000	1000	120	122
Williamsburgh.....	1,000,000	50	119	122
“ Bonds... ..	1,000,000	—	108	112
Out of Town Gas Companies.				
Boston United Gas Co. —				
1st Series S.F. Trust	7,000,000	1000	93	93½
2d “ “ “	3,000,000	1000	71	72
Bay State Gas Co. --				
Stock.....	5,000,000	50	24	25
Income Bonds.....	2,000,000	1000	—	—
Buffalo Mutual, N. Y... ..	750,000	100	90	95
“ Bonds... ..	200,000	1000	95	100
Citizens, Newark.....	1,000,000	50	155	160
“ “ Bonds.	45,000	—	—	—
Chicago Gas Trust.....	25,000,000	100	44¾	—
Chicago Gas Light. & Coke Co. --				
G'd Gold Bonds	7,650,000	1000	94½	94¾
Equitable Gas & Fuel Co., Chicago, Bonds	2,000,000	1000	97	—
People's Gas and Coke Co., Chicago --				
1st Mortgage.....	2,100,000	1000	—	99
2d “	2,500,000	1000	96	100
Consumers Gas Light Co., Jersey City.....	2,000,000	100	15	25
Bonds.....	600,000	1600	80	—
Cincinnati G. & C. Co..	6,000,000	100	201	203
Consumers Toronto....	1,000,000	50	190	200
Central, S. F., Cal.....	—	—	80	90
Capital, Sacramento, Cal	—	—	58	—
Consolidated, Balt.....	11,000,000	100	52½	53
“ Bonds.....	6,400,000	—	107	107½
Hartford, Conn.....	750,000	25	102	108
Jersey City.....	750,000	20	186	190
Laclede Gas Light Co., St. Louis, Mo. —				
Common Stock....	7,500,000	100	15	16
Preferred “	2,500,000	100	—	—
Bonds.....	9,034,400	1000	84¾	85½
Louisville, Ky.....	2,570,000	50	125	130

Little Falls, N. Y.....	50,000	100	—	100
“ Bonds	25,000	—	100	103
Montreal, Canada.....	2,000,000	100	200	208
Memphis (Tenn.) Gas... ..	750,000	100	48	51
“ Bonds.	240,000	100	103	—
New Haven, Conn.....	—	25	200	—
Oakland, Cal.....	—	—	35	35½
Peoples, Jersey City... ..	—	—	60	61
“ “ Bonds..	—	—	—	—
Paterson, N. J.....	—	25	99	102
Rochester, N. Y.....	—	50	99	100
Syracuse, N. Y.....	500,000	25	—	—
San Francisco Gas Co.				
San Francisco, Cal....	10,000,000	100	55½	55¾
Washington, D. C.....	2,000,000	20	200	208
Wilmington, Del.	—	50	88	90

Advertisers Index.

	Page
GAS ENGINEERS.	
Jos. R. Thomas, New York City	268
Wm. Henry White, New York City	271
Wm. Mooney, New York City.....	268
William Gardner, Pittsburgh, Pa.....	268
Fred. Bredel, N. Y. City.....	267
GAS AND WATER PIPES.	
Gloucester Iron Works, Phila., Pa	268
Mellert Foundry and Machine Co., Reading, Pa. (John Fox, Selling Agent, N. Y.).....	268
Ohio Pipe Co., Columbus, Ohio.....	268
M. J. Drummond, New York City.....	268
R. D. Wood & Co., Phila., Pa.....	270
Warren Foundry & Machine Co., New York City.....	268
Donaldson Iron Co., Emaus, Pa.....	268
Dennis Long & Company, Louisville, Ky.....	268
GAS WORKS APPARATUS AND CONSTRUCTION.	
James R. Floyd & Sons, New York City	271
Continental Iron Works, Greenpoint, L. I.	271
Delly & Fowler, Phila., Pa	271
Kerr Murray Mfg. Co., Fort Wayne, Ind	259
Stacey Mfg. Co., Cincinnati, Ohio	271
Bartlett, Hayward & Co., Baltimore, Md.....	269
Morris, Tasker & Co., Limited, Phila., Pa.....	269
Davis & Farnum Mfg Co., Waltham, Mass.....	223
R. D. Wood & Co., Phila., Pa.....	270
Bouton Foundry Co., Chicago, Ills	271
Smith & Sayre Manufacturing Co., New York City.....	270
Fred. Bredel, N. Y. City.....	267
United Gas Improvement Co., Phila., Pa.....	261
Ifenry Pratt & Co., Chicago, Ill.....	267
National Gas Light and Fuel Co., Chicago, Ills.....	262
Simpkin & Hillyer, Richmond, Va.	256
PROCESSES.	
National Gas Light and Fuel Co., Chicago, Ills.....	262
Bartlett, Hayward & Co., Baltimore, Md.....	269
Wm. Henry White, N. Y. City... ..	271
United Gas Improvement Co., Phila., Pa	261
Henry Pratt & Co., Chicago, Ill	237
The Fuel Gas and Light Improvement Co., N. Y. City.....	256
INCLINED RETORTS.	
Laclede Fire Brick Manuf'g Co., St. Louis, Mo.....	259
GASHOLDER TANKS.	
W. C. Whyte, New York City... ..	262
J. P. Whittier, Brooklyn, N. Y.....	273
GASHOLDER PAINT.	
The Government Waterproof Paint Co., Boston, Mass.....	275
RETORTS AND FIREBRICK.	
J. H. Gantler & Co., Jersey City, N. J	265
B Kreischer & Sons, New York City	266
Adam Weber, New York City.....	266
Laclede Fire Brick Manuf'g Co., St. Louis, Mo	236
Brooklyn Retort and Fire Brick Works, Brooklyn, N. Y	266
Borgner & O'Brien, Phila., Pa	266
James Gardner, Jr., Pittsburgh, Pa.....	266
Henry Maurer & Son, New York City.....	267
Chicago Retort and Fire Brick Co., Chicago, Ills.....	266
Baltimore Retort and Fire Brick Co., Baltimore.....	266
Oakhill Gas Retort and Fire Brick Co., St. Louis, Mo.....	266
SCRUBBERS AND CONDENSERS.	
G. Shepard Page, New York City	260
R. D. Wood & Co., Phila., Pa.....	270
REGENERATIVE FURNACES.	
Bartlett, Hayward & Co., Baltimore, Md.....	269
Fred. Bredel, New York City	267
Chicago Retort and Firebrick Co., Chicago, Ills.....	266
Wm. Henry White, N. Y. City... ..	271
J. H. Gaudier & Co., Jersey City, N. J.....	266

GAS GOVERNORS.

Connelly & Co., New York City.....	263
Fred. Bredel, N. Y. City.....	267
Friedrich Lux, London, England.....	255

SELF-SEALING MOUTHPIECE DOORS.

Smith & Sayre Mfg. Co., New York City.....	270
--	-----

TAR AND CARBONIC ACID EXTRACTOR.

Geo. Shepard Page, N. Y. City.....	224
------------------------------------	-----

CEMENTS.

C. L. Gerould & Co., Brooklyn, N. Y.....	260
--	-----

GAS ENRICHERS.

Standard Oil Co., Cleveland, Ohio.....	272
--	-----

GAS METERS.

John J. Griffin & Co., Phila., Pa.....	274
American Meter Co., New York and Philadelphia.....	275
The Goodwin Gas Stove and Meter Co., Philadelphia, Pa.....	275
Helme & McHenry, Phila., Pa.....	277
D. McDonald & Co., Albany, N. Y.....	277
Nathaniel Tufts, Boston, Mass.....	274
Maryland Meter and Manufacturing Co., Baltimore, Md ..	238
John Hillen, Brooklyn, N. Y.	275
Bell & Jones, Philadelphia, Pa.....	274

EXHAUSTERS.

The P. H. & F. M. Roots Co., Connersville, Ind.....	258
Smith & Sayre Manufacturing Co., New York City.....	270
Wilbraham Bros., Philadelphia, Pa.....	263
Connelly & Co., New York City.....	263

GAS COALS.

Penn Gas Coal Co., Phila., Pa	273
Perkins & Co., New York City	272
Newburgh Orrel Coal Co., Baltimore Md.....	273
Despard Coal Co., Baltimore, Md	273
Chesapeake and Ohio R. R. Coal Agency, N. Y. City.....	273
Westmoreland Coal Company, Phila., Pa.....	273
J. & W. Wood, New York City.....	272

CANNEL COALS.

Perkins & Co., New York City.....	272
J. & W. Wood, New York City.....	272

VALVES.

Ludlow Valve Manufacturing Co., Troy, N. Y.....	264
John McLean, New York City.....	264
Chapman Valve Manufacturing Co., Boston, Mass	264
R. D. Wood & Co., Phila., Pa.....	270
The P. H. & F. M. Roots Co., Connersville, Ind.....	258

GAS ENGINES.

Schleicher, Schumm & Co., Phila., Pa	276
Clerk Gas Engine Co., Phila., Pa.....	264
Van Duzeu Gas Engine Co., Cincinnati, Ohio.....	264

ENGINES AND BOILERS.

Jarvis Engineering Co., Boston, Mass.....	263
Ball Engine Co., Erie, Pa.....	255
Westinghouse Machine Co., Pittsburgh, Pa.....	267

GAS LAMPS.

G. Shepard Page, New York City.....	228
Standard Gas Lamp Co., Phila., Pa.....	256
Welshach Incandescent Gas Light Co., Phila., Pa.....	257
The Siemens-Lungren Company, Philadelphia, Pa.....	257

PURIFIER SCREENS.

John Cahot, New York City... ..	264
Bartlett, Hayward & Co., Baltimore, Md.....	264

GAS STOVES.

American Meter Co., New York and Philadelphia.....	265
The Goodwin Gas Stove and Meter Co., Phila., Pa	240
George M. Clark & Company, Chicago, Ills.....	257
D. McDonald & Co., Albany, N. Y.....	266
Maryland Meter and Manufacturing Co., Baltimore, Md.	274
Bell & Jones, Philadelphia, Pa.....	274

STREET LAMPS.

J. G. Miner, Morrisania, New York City.....	256
Bartlett Street Lamp Man'g Co., New York City.....	256

BURNERS.

C. A. Gefrorer, Phila., Pa.....	272
---------------------------------	-----

STEAM BLOWER FOR BURNING BREESE.

H. E. Parson, New York City.....	264
----------------------------------	-----

PURIFYING MATERIAL.

Connelly & Co., New York City.....	263
Friedrich Lux, London, England.....	255
Edgewater Lime Works, Edgewater, N. J.....	255

COKE CRUSHER.

C. M. Keffler, Columbus, Ind. 273

ELECTRICAL APPARATUS.

Wm. Henry White, N. Y. City..... 271

SOLVENTS.

Maas & Waldstein, New York City..... 263

BOOKS, ETC.

Gerould's System Gas Bookkeeping..... 255
 1889. Directory. 1889 266
 King's Treatise 268
 Scientific Books 274
 Management of Small Gas Works 264
 Gas vs. Electricity 256
 Practical Electric Lighting..... 263
 Electric Light Primer..... 263
 American Gas Engineer and Superintendents' Handbook... 273
 Digest of Gas Law..... 255
 Fuel and its Applications 255

WANTED,

A young man to act as

Meter Taker and to Make Himself Useful

in a small Gas Works. Must understand gasfitting and be strictly temperate. Address, with references, 768-2 "G.," care this Journal.

POSITION WANTED

As Manager of a Gas Works

Making from 5 to 10 million cubic feet per annum. Six years' experience. Address "J. M. M.," 767-4 Care this Journal.

POSITION WANTED.

A Mechanical Engineer,

Experienced in Gas Manufacture, wishes a position as Superintendent of a Gas Works. Best of references given and asked. Salary, \$1,200.

"MECHANICAL ENGINEER," care this Journal, 765-1f or Box 972, West Bay City, Mich

Position Wanted

As Superintendent or Assistant of a Gas Works,

By a man who can give the best of references. Thoroughly understands the manufacture and distribution of gas and the construction of works. Address 765-5 "M.," care this Journal.

FOR SALE.

We offer the following gas apparatus for sale, delivered f.o.b. cars Fort Worth, Texas:

Two Benches of 3's, with cast iron Hydraulic Main, Dip and Ascension Pipes, and Mouthpieces (14 by 23 in.).

One Bench of 6's, with cast iron Hydraulic Main, Dip and Ascension Pipes, and Mouthpieces (12 by 20 in.).

Two Benches of 3's, with cast iron Hydraulic Main, Dip and Ascension Pipes, and Mouthpieces (14 by 24 in.).

Four Purifiers, 6 ft. by 6 ft., with 6-in. Connections and Center Seal. **Steam Jet Exhauster** **One Set Pipe Condensers** 6-in.) **One Upright Scrubber,** 11 ft. high by 36 in. diam., with Bye-Pass **One Station Meter,** daily capacity 100,000 cu. ft. **One Upright Boiler,** 20 horse power.

All of above apparatus in first-class condition and are so guaranteed. For further particulars address

FORT WORTH LT. AND POWER CO.,

767-1

Fort Worth, Texas.

GAS WORKS FOR SALE.

A CONTROLLING INTEREST IN SEVERAL

Interior California Coal Gas Plants,

now paying handsomely, are offered on very reasonable terms. This is an exceptionally good opportunity for practical gas men of limited means, wishing to remove to a mild and healthful climate, to acquire an established and paying business. Particulars given and full investigation solicited.

SECRETARY, 123 Beale Street,

760-3 mos.

San Francisco, Cal.

FOR SALE.

A Complete Water Gas Plant.

60,000 Cu. Ft. Daily Capacity.

Fully equipped; all the latest improvements; includes Generator, Purifiers, and Holder. Can be removed to any part of the country, and set up at small cost. For further information apply to BRADFORD GAS LT. & HEATING CO., Dunkirk, N. Y.

FOR SALE,

One Hydraulic Main (five sections), wrought iron, 22

by 24, with Bye-Pass on Dip-Pipes.

25 Valves, Stand-Pipes, 7-inch Mouthpieces and Lids, all complete, ready for use, to fit up five benches of 5's.

This apparatus is all in first-class condition.

Price, \$800, f.o.b. cars or boat, Poughkeepsie, N. Y.

Inquiries may be sent to this Office.

6 PER CENT.

First Mortgage Bonds

ON GAS WORKS

SITUATED IN GROWING WESTERN TOWNS.

Principal and Interest Guaranteed.

INTEREST SEMI-ANNUALLY.

For sale by the undersigned, who will furnish all necessary information regarding them.

JOS. R. THOMAS, 42 Pine St., N. Y. City.

FRIEDRICH LUX,

Ludwigshafen am Rhein and London.

Lux Mass

GAS GOVERNORS,

Gas Balance.

Fuel and Its Applications.

By E. J. MILLS, D.Sc. F.R.S., and F. J. ROWAN, C.E., assisted by others, including Mr. F. P. Dewey, of the Smithsonian Inst., Wash., D. C.

7 PLATES, AND 607 OTHER ILLUSTRATIONS. ROYAL OCTAVO, PAGES xx, 802. HANDSOME CLOTH, \$7.50.

A. M. CALLENDER & CO., 42 Pine St., N. Y.

GEROULD'S

System Gas Bookkeeping.

Approved and adopted by many of the prominent Gas Engineers of the Country.

Sample Sheets and Price-List furnished free on application to

L. P. GEROULD, - - Mendota Ill.

EDGEWATER LIME WORKS

Chas. F. McKenna, Proprietor.

SHELL LIME.

Lime by the Cargo for Gas Purification.

EDGEWATER, BERGEN CO., N. J.

Write for Testimonials and Prices.

GREENOUGH'S

"DIGEST OF GAS LAW."

Price, \$5.00.

This is a valuable and important work, a copy of which should be in the possession of every gas company in the country, whether large or small. As a book of reference it will be found invaluable. It is the only work of the kind which has ever been published in this country, and is most complete. Handsomely bound. Orders may be sent to

A. M. CALLENDER & CO.,

42 Pine Street, N. Y.

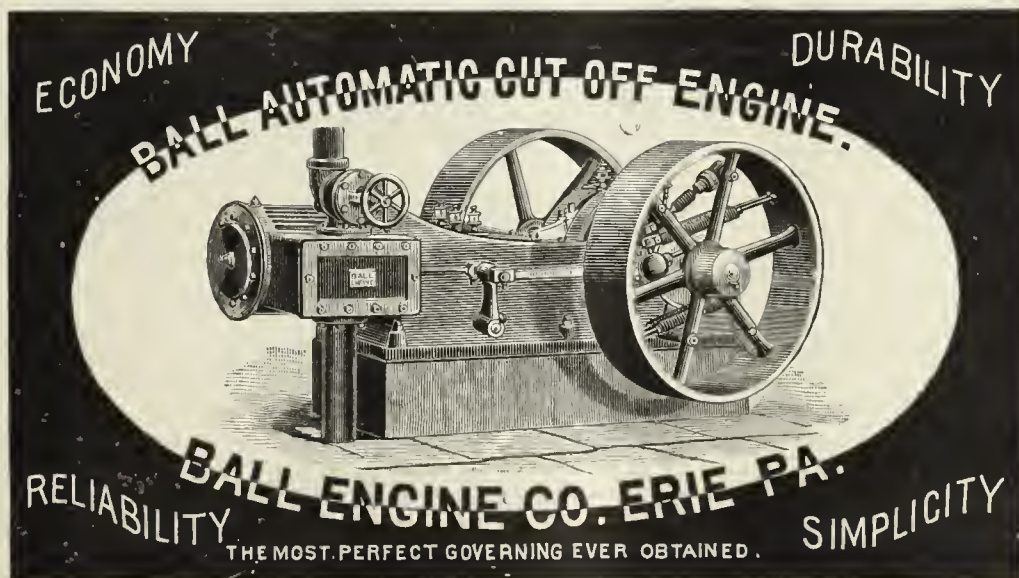

GASHOLDER PAINT.

Use Only

THE GOVERNMENT WATERPROOF PAINT.

Proof against Ammonia, and Absolutely Waterproof. Send for Prices and Particulars.

THE GOVERNMENT WATERPROOF PAINT CO., 122 Milk Street, Boston, Mass.

F. D. HARMON, PRES.

CHAS. C. ALLEN, SEC. AND TREAS.

P. W. MACKENZIE, CHIEF ENGR. & SUPT.

THE FUEL GAS AND LIGHT IMPROVEMENT CO.

OF AMERICA.

Owners of the RECENT Mackenzie Patents,

For the United States, England, Russia, France, Germany, Austria, and Canada,

No. 32 Park Place, New York City.

This SYSTEM is an ABSOLUTELY NEW DEPARTURE IN THE MANUFACTURE OF FUEL AND ILLUMINATING GAS. The COST OF GAS IN THE HOLDER by our System is at least THIRTY PER CENT. LESS than that made by any other process of the day.

The Gas is manufactured WHOLLY from LIQUID HYDROCARBONS, such as Lima, Penn, Crude, and Fuel Oils, Naphtha, etc. Neither PERISHABLE PIPES or other RETORTS, NOR THEIR EQUIVALENTS, are used.

Neither COAL, COKE, nor any other HARD CARBONS enter into the manufacture or composition of the Gas, thereby requiring LESS LABOR THAN ANY OTHER METHOD.

The Gas contains neither SULPHUR nor other impurities, nor is there any resultant LAMPBLACK OR TAR RESIDUUM.

The Gas requires NO PURIFICATION whatever.

The FUEL GAS COSTS VERY MUCH LESS than PURE UNCARBURETED WATER GAS, and contains DOUBLE THE HEAT UNITS.

The APPARATUS is extremely SIMPLE, SUBSTANTIAL, and DURABLE, and consists of a Single Body with a capacity of ONE THOUSAND to ONE HUNDRED THOUSAND cubic feet per hour.

Works may be constructed to run by the CONTINUOUS or ALTERNATING method. If run continuously, the limited amount of Nitrogen present is neutralized by Carbon.

The Gas can be made of a HIGH GRADE for illuminating purposes, of a MEDIUM QUALITY for distribution for domestic purposes, and of a LOW GRADE for manufacturing uses.

Wherever Liquid Hydrocarbons can be had the MACKENZIE PROCESS WILL COMPETE IN PRICE AND SUPPLY ALL THE ADVANTAGES incidental to the use of NATURAL GAS.

This Company desires contracts for the construction of Plants, parts of Plants, Apparatus, Buildings, Holders, and Street Mains, for either of the above purposes, and will Lease or Purchase Works upon satisfactory terms.

Information will be promptly given regarding material required for production of Gas, actual cost of product, cost of works, etc.

Bartlett Street Lamp Mfg. Co.

MANUFACTURERS OF

Globe Lamps,

FOR

Streets, Parks, Public Buildings, Railroad Stations, etc.

LAMP POSTS

A Specialty.

Office and Salesroom,

40 & 42 COLLEGE PLACE, - - N. Y. CITY.

Gas Companies and others intending to erect Lamps and Posts will do well to communicate with us.



No. 29 Champion.

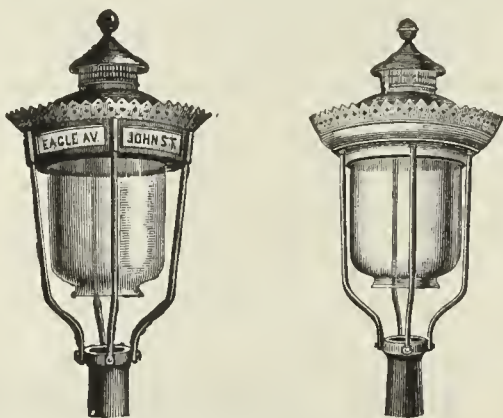

The Miner Street Lamps.

Jacob G. Miner,

No. 823 Eagle Ave., New York, N. Y.

GAS vs. ELECTRIC LIGHT.

We would invite attention to the able and exhaustive argument of General A. Hickenlooper, President of the Cincinnati Gas Light and Coke Company, contained in a handsome pamphlet of 96 pages, entitled

"EDISON'S INCANDESCENT ELECTRIC LIGHTS FOR STREET ILLUMINATION. REPORT OF AN ARGUMENT DELIVERED BY A. HICKENLOOPER BEFORE THE COMMITTEE ON LIGHT, MUNICIPAL COUNCIL, CITY OF CINCINNATI, JULY 22, 1886."

This is a subject of special interest to all Gas Light Companies.

Prices.

25 copies.....	\$7.50	100 copies.....	\$22.50
50 copies.....	12.50	250 copies.....	50.00

A sample copy will be sent by mail on receipt of 50 cts
U. M. CALLENDER, & CO., 42 PINE ST., N. Y. CITY

Simpkin & Hillyer

RICHMOND, VA.

MANUFACTURERS OF

Gas Works Apparatus

BENCH CASTINGS, CONDENSERS, Scrubbers, Purifiers, Dry Center Seals, FOUR-WAY VALVES, GAS VALVES, SULPHATE OF AMMONIA APPARATUS, TANKS, ENGINES, BOILERS, PUMPS, ETC., ETC.

Plans, Specifications and Estimates furnished for new works, or alteration of old works. Correspondence solicited. Works, Newport News, Va.

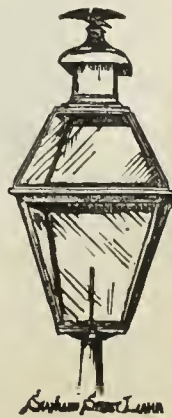

Simpkin & Hillyer

PHILADELPHIA. NEW YORK. CHICAGO.
STEPHEN A. MORSE, President. EDWIN F. MORSE, Secretary.
GODFREY REBMANN, Vice-Pres. CARLTON M. WILLIAMS, Treas.

STANDARD GAS LAMP CO.,

Main Office, 411 Cherry St. Factory, 1101, 1103, 1105 Frankford Av.
PHILADELPHIA, PA.

It is to the interest of Gas Companies and Cities to double the efficiency of the light on streets by using Dyott's Patent "CHAMPION" LAMPS. They save 50 per cent. over others in cost of repairs, are ornamental, and indestructible except by violence.

Our Patent System of Instantaneously Lighting Gas (without electricity), for Railroad Depots is unequalled.

Dyott's High Candle Power Burner is a very superior lamp where a concentrated and brilliant light is wanted in Hotels, Stores, Depots, etc.

Special Drawings furnished and Estimates cheerfully given, either from Architects, Engineers, or our Draughtmen's Plans.

We manufacture every description of Plain and Ornamental Lamps, Posts, Brackets, Clusters, etc. Correspondence solicited.

The Gordon Portico Lamp.

A successful Competitor of the Arc Electric Light for lighting Store Fronts, Show Windows, Depots, Railway Sheds, etc., etc.

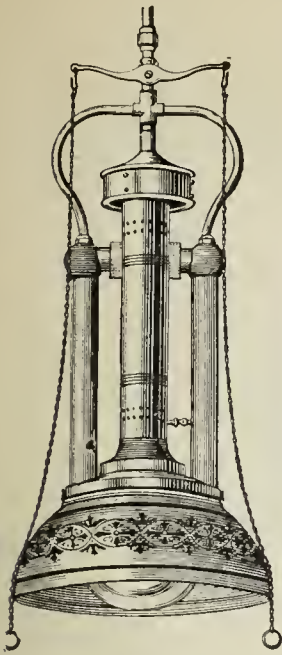

Gordon Portico Lamp.

The Gordon Street Lamp.

A Successful Competitor of the Arc Electric Light for lighting Streets, etc., etc.

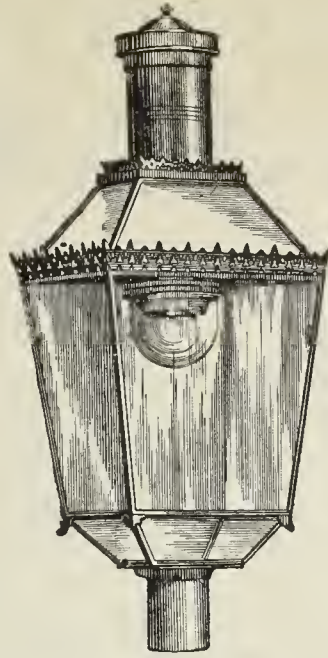

Gordon Street Lamp.

The Lungren Lamp.

A Successful Competitor of the Incandescent Electric Light for Interiors, etc. Is especially applicable for the lighting of Offices, Stores, Factories, Mills, Show Windows, Libraries, and all situations where an increased illumination is desired.

More than 25,000 Lungren Lamps are now in use. Testimonials, references, or any desired information will be cheerfully given.



Lungren Lamp.

THE SIEMENS-LUNGREN CO., N.E. Cor. 21st St. & Washington Av., PHILADELPHIA.

WELSBACH SYSTEM OF Incandescent Gas Lighting.

OFFICE, DREXEL BUILDING, PHILA., PA.

At the Fall Session of the Board of Supervisors of Winnebago County, held at the County Court House, Oshkosh, Wis., Nov. 26, 1889, the report submitted by Mr. C. W. Cook, Chairman of the Committee on Public Buildings, recommending the use of the Welsbach Incandescent Gas Burner in the Buildings under their charge, was unanimously adopted, because of the extreme economy in the consumption of Gas and the superior character of the light obtained.

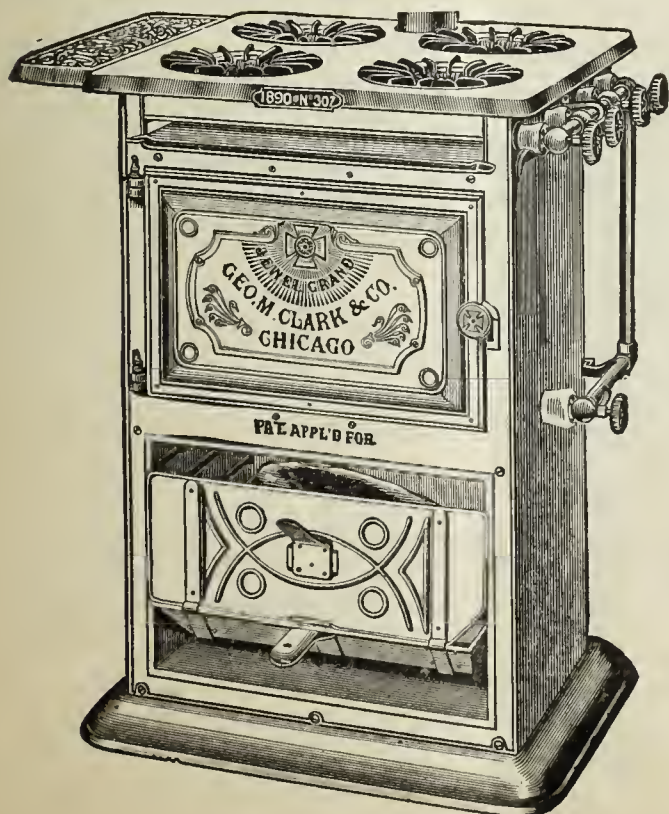

JEWEL GAS STOVES

MANUFACTURED BY

GEORGE M. CLARK & COMPANY,

Nos. 157 & 159 Superior Street, - - - Chicago, Ill.

EVERY CONCEIVABLE SIZE AND STYLE,

Ranging in Prices from \$1.50 to \$30.00.

WE USE NO GAS COCKS.

All Flames are Regulated by a Direct Needle Valve.

The **JEWEL**

IS THE

Only Well-Made Gas Stove on the Market.

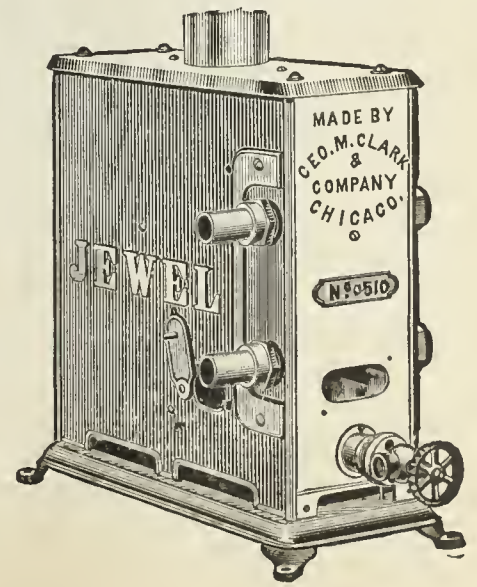

Write for our 1890 Catalogue and see for yourself.

ROOTS' GAS AND BYE-PASS VALVES.

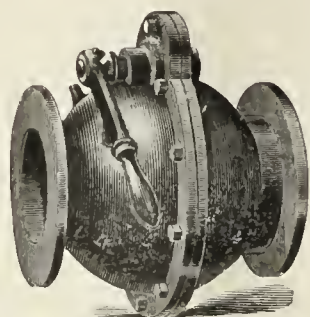

GAS VALVE

Quick Acting,
Simple,
Efficient, Durable.

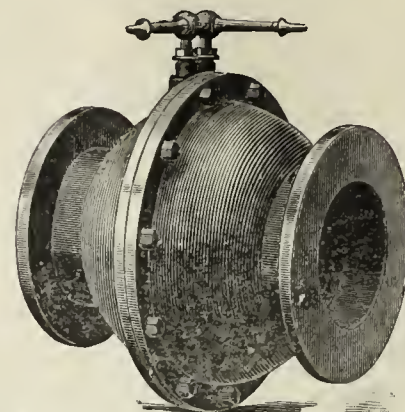

BYE-PASS VALVE.

Automatic Action,
Reliable,
Simple, Durable.

Thousands now in use and giving perfect satisfaction. Write for Catalogue and Prices.

ROOTS' NEW GAS EXHAUSTER.

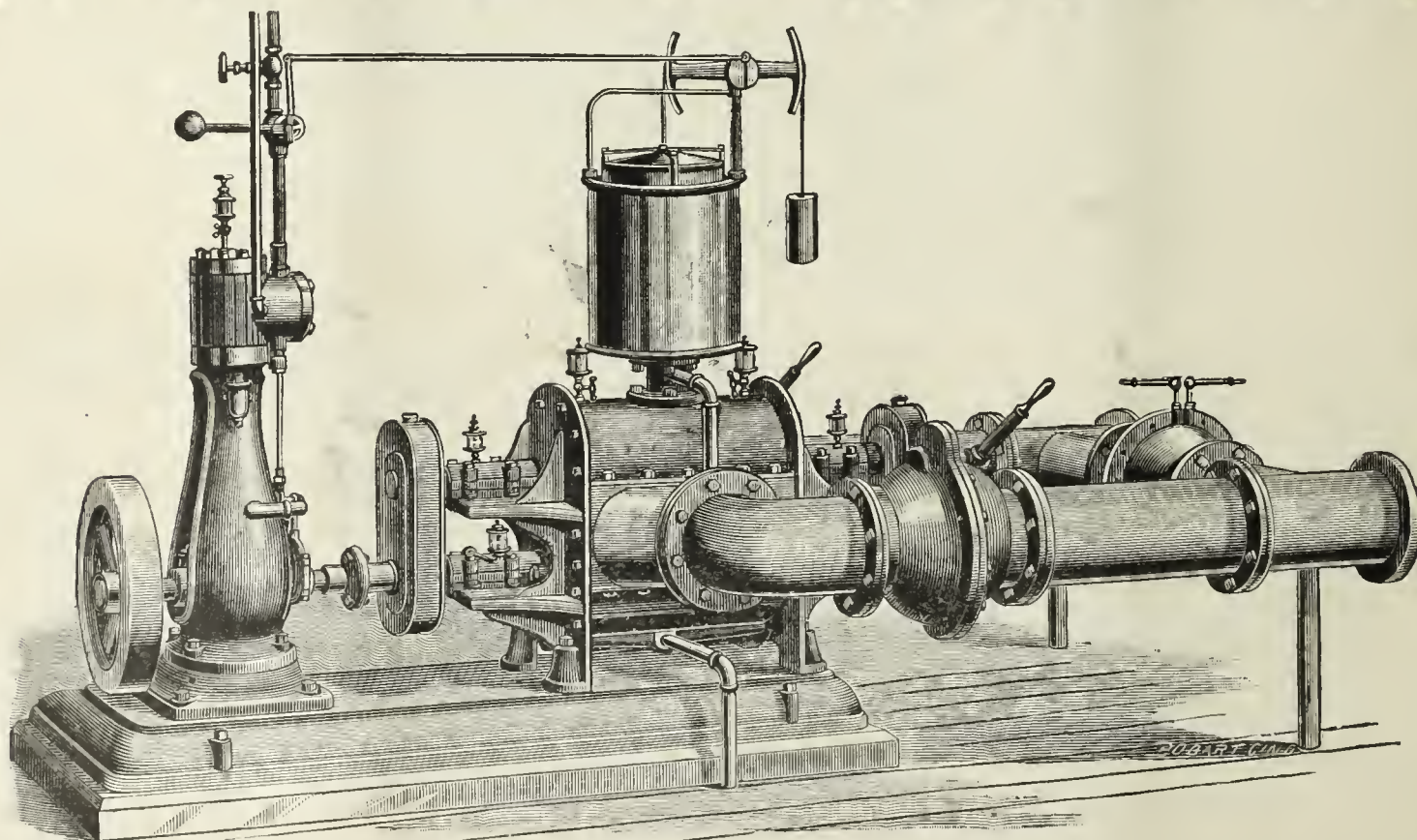

We will take pleasure in furnishing estimates on complete plants, including **GAS EXHAUSTER, ENGINE,** and **GAS GOVERNOR,** all connected, complete, on same bedplate. Also, estimates for **GAS VALVES, BYE-PASS VALVES,** and **PIPE FITTINGS,** arranged in any manner to suit the exhauster room or main connections.

All flanges of pipe and valve fittings faced off, with bolt holes drilled, all ready to go together.

S. S. TOWNSEND, General Agent, }
COOKE & CO., Selling Agents, } 22 Cortlandt St., N. Y. **P. H. & F. M. ROOTS CO.,** Connersville, Ind.

THIS SPACE
 WILL BE
 Occupied Next Month by the
KERR MURRAY MFG. CO.
 FORT WAYNE, IND.
**GAS WORKS
 APPARATUS
 AND
 HOLDERS.**

LACLEDE FIRE BRICK MANUFACTURING COMPANY,

ST. LOUIS, MO.

Exclusive Agents in the United States

FOR THE

Coze System of Inclined Retorts.

IT IS THE COMING BENCH
FOR MAKING COAL GAS.

*It will Save from 50 to
60 per ct. in Labor.*

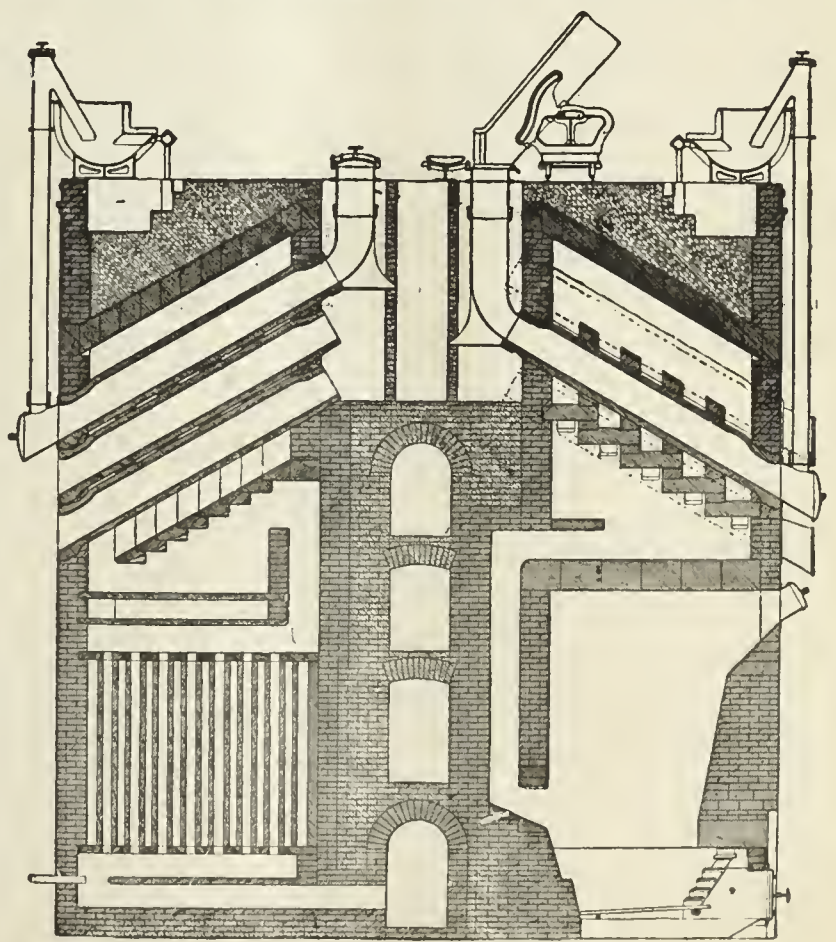
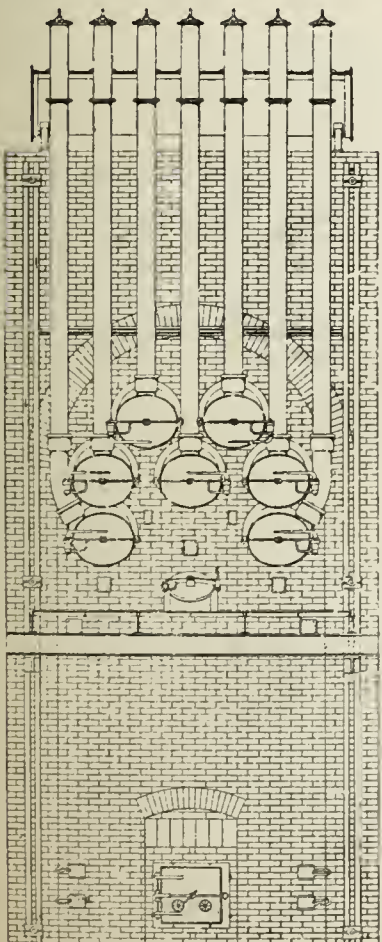

ESTIMATES AND PLANS FURNISHED BY THE

LACLEDE FIRE BRICK MFG. CO., ST. LOUIS, MO.

KIRKHAM, HULETT & CHANDLER, LIMITED.

PATENT "STANDARD" WASHER-SCRUBBERS

Erected and in course of construction at present date:

Capacity. Cubic feet per day.	Capacity. Cubic feet per day.	Capacity. Cubic feet per day.	Capacity. Cubic feet per day.
Altrincham..... 600,000	Dublin..... 3,000,000	LONDON—Continued.	Ober Schlesian..... 1,500,000
Adelaide..... 600,000	Dowlais..... 100,000	Shoreditch..... 2,500,000	Otto & Co.'s Coke Works.... 1,500,000
Aldershot..... 200,000	Donai..... 500,000	Pancras..... 1,500,000	Plymouth..... 2,000,000
Allegheny, U. S. A..... 1,000,000	Denton..... 500,000	"..... 1,500,000	Parramatta, N. S. W..... 100,000
Ashton-under-Lyne..... 1,250,000	Derby, U.S.A. 350,000	Pimlico..... 2,000,000	Prescott..... 150,000
Amsterdam..... 1,500,000	Denver, " 500,000	Nine Elms..... 3,000,000	Providence, U.S.A. 750,000
"..... 1,500,000	"..... 1,000,000	"..... 3,000,000	"..... 750,000
Annaberg..... 200,000	Dusseldorf..... 750,000		Plauen..... 300,000
Areachon..... 100,000	"..... 500,000		"..... 300,000
Animal Chareoal Co..... 200,000	Dnmfries..... 250,000	South Metropolitan Co:—	Portsmouth..... 2,500,000
Altoona, U.S.A..... 350,000	Dnnedin, N.Z..... 400,000	Greenwich..... 3,000,000	"..... 2,500,000
Bnxtton..... 250,000	Darlington..... 1,250,000	Woolwich..... 400,000	Pittsburgh, U.S.A. 1,500,000
Bradford..... 1,000,000	Detroit, U.S.A. 750,000	Vauxhall..... 3,000,000	Portland, " 560,000
"..... 1,250,000	Edinburgh..... 1,500,000	"..... 3,000,000	Pawtucket, " 500,000
"..... 1,250,000	"..... 2,000,000	Lea Bridge..... 300,000	Quebec 250,000
"..... 1,250,000	Enfield..... 300,000	West Ham..... 1,500,000	Radelife..... 750,000
"..... 1,000,000	Essen..... 300,000	"..... 1,500,000	Rouen..... 250,000
"..... 1,000,000	Elbing..... 150,000	Leeds..... 2,000,000	Ramsgate..... 1,000,000
"..... 3,000,000	Falmouth..... 150,000	"..... 3,000,000	Reigate..... 200,000
Bremen..... 150,000	Frankfort..... 300,000	"..... 3,000,000	Richmond, U.S.A. 250,000
Baltimore, U.S.A. 1,000,000	Farnworth..... 400,000	"..... 3,000,000	Roxbury, " 500,000
"..... 1,000,000	Fenton..... 400,000	"..... 3,000,000	Rnucorn Soap Co..... 20,000
"..... 1,000,000	Friedenshutte..... 500,000	"..... 2,000,000	Rockhampton, N. S. W..... 125,000
Balmain, N.S.W..... 125,000	Furth..... 400,000	Leominster..... 150,000	Richmond..... 1,500,000
Bishops Stortford..... 150,000	Freiburg..... 200,000	Leiden..... 560,000	Reading..... 2,000,000
Blackpool..... 400,000	Goole..... 250,000	"..... 600,000	Reichenbach..... 200,000
Brussels..... 1,250,000	Glossop..... 300,000	Liverpool..... 2,000,000	Salford..... 1,750,000
"..... 1,250,000	Guilford..... 300,000	"..... 2,000,000	"..... 1,750,000
"..... 750,000	Gloucester..... 1,250,000	"..... 2,000,000	"..... 1,750,000
"..... 1,250,000	Gera..... 300,000	"..... 2,000,000	Smethwick..... 750,000
Banbury..... 250,000	Grafton, N.S.W..... 100,000	"..... 2,000,000	Sydney, N. S. W..... 1,000,000
Birmingham..... 5,000,000	Grieg..... 300,000	"..... 2,000,000	"..... 1,000,000
Birkenhead..... 2,500,000	Georgetown, U.S.A. 250,000	"..... 3,000,000	"..... 2,500,000
Blackburn..... 1,500,000	Glnekauf..... 200,000	Lincoln..... 1,000,000	"..... 50,000
Bochum..... 600,000	Heywood..... 600,000	"..... 600,000	"..... 50,000
Burntisland..... 250,000	Holywood..... 125,000	Lowell, U. S. A. 1,000,000	Sunderland..... 1,500,000
Boston, U.S.A. 2,000,000	Huy..... 70,000	Louisville " 1,500,000	St. Josephs, U.S.A. 250,000
Brisbane..... 1,500,000	Harrow..... 250,000	Long Eaton..... 500,000	Spa..... 100,000
"..... 300,000	Harrogate..... 250,000	Lilie..... 450,000	Sevenoaks..... 300,000
Burton-on-Trent..... 1,500,000	Halstead..... 150,000	"..... 750,000	St. Petersburg..... 2,000,000
Barcelona..... 350,000	Heilbronn..... 200,000	"..... 250,000	"..... 1,500,000
Barking..... 100,000	Havana, Cuba. 750,000	"..... 250,000	St. Louis, U.S.A. 2,000,000
Baerlien & Co..... 20,000	Hastings..... 1,500,000	Luckenwalde..... 330,000	"..... 2,000,000
"..... 20,000	Huddersfield..... 300,000	Liegwitz..... 300,000	"..... 1,000,000
Bombay..... 400,000	"..... 750,000	Lincoln, U. S. A. 250,000	Laclede 1,000,000
Buffalo, U.S.A., Mutual 750,000	"..... 1,500,000	Lawrence " 500,000	Silesian Coal Co..... 600,000
Citizen 500,000	Hof..... 200,000	Lynn " 300,000	San Francisco, U.S.A. 2,000,000
Brookline, U.S.A. 500,000	Hampton Wick..... 500,000	Lyons..... 1,500,000	"..... 2,000,000
Bergen..... 350,000	Heckmondwicke..... 500,000	Maidstone..... 1,000,000	Sheepbridge Coal Co..... 40,000
Berlin..... 1,250,000	Haverfordwest..... 100,000	Marseilles..... 1,500,000	Stettin..... 200,000
Bonnremouth..... 1,000,000	Halifax, N.S. 350,000	"..... 1,500,000	Singapore..... 300,000
Bridgeport, U.S.A. 500,000	Hamm..... 200,000	Malsines..... 250,000	Sntton..... 500,000
Brunswick..... 300,000	Halle..... 400,000	Melbourne..... 1,500,000	Tonbridge..... 150,000
Beck & Co., St. Louis 100,000	Heidelberg..... 300,000	"..... 1,500,000	Tipton..... 400,000
Barmen Rittershausen..... 600,000	Hartford, U.S.A. 1,000,000	"..... 1,500,000	Totteuham..... 1,000,000
Bexhill..... 125,000	Ilkeston..... 300,000	"..... 1,500,000	Toledo, U.S.A. 750,000
Brooklyn, U.S.A. 1,000,000	Inverness..... 200,000	"..... 1,500,000	Toronto 1,000,000
"..... 1,000,000	Ikley..... 200,000	"..... 1,500,000	Uxbridge..... 300,000
"..... Nassau 1,000,000	Ilford..... 100,000	Manchester..... 2,500,000	Valparaiso 500,000
Brunner, Mond & Co..... 400,000	Kingston-on-Hull..... 400,000	Middleton..... 400,000	West Bromwich..... 1,000,000
Cheltenham..... 2,000,000	Kidderminster..... 750,000	Manley, N. S. W..... 100,000	Willenhall..... 250,000
Cannes..... 200,000	Kidsgrove..... 100,000	Minueapolis, U. S. A. 750,000	Weston super-Mare..... 500,000
Croydon..... 1,500,000	Konigberg..... 1,000,000	Magdeburg..... 300,000	Waltham..... 150,000
Copenhagen..... 200,000	King's Lynn..... 300,000	Memphis, U. S. A. 750,000	Wormwood Scrubs..... 300,000
Clevedon..... 200,000		Nottingham..... 1,250,000	Williamsburg, U.S.A. 600,000
Columbus, U.S.A. 500,000	LONDON:—	"..... 2,500,000	"..... 600,000
Cincinnati, " 1,500,000	The Gaslight and Coke Co. :	"..... 2,500,000	Wellington..... 150,000
"..... 1,500,000	Beckton..... 1,250,000	"..... 2,000,000	Warwick..... 300,000
Chicago 3,000,000	"..... 1,250,000	"..... 1,500,000	Wheeling, U.S.A. 500,000
"..... 1,000,000	"..... 1,250,000	"..... 2,000,000	Walker..... 300,000
"..... 1,000,000	"..... 1,250,000	Newport, U.S.A. 430,000	Westgate..... 100,000
Chemnitz..... 1,000,000	"..... 1,250,000	Newmarket..... 150,000	Wilmington, U.S.A. 500,000
Crewe..... 1,250,000	"..... 1,250,000	Newark, U.S.A. 680,000	Windsor, N. S. W..... 100,000
Colonial Gas Works Co..... 100,000	"..... 1,250,000	Northfleet..... 200,000	Wolverton..... 100,000
Cadiz..... 300,000	"..... 2,500,000	New York, U.S.A. 2,000,000	Wellington, N. Z..... 250,000
Charlottenburg..... 600,000	"..... 2,500,000	Nice..... 600,000	Whitchurch..... 175,000
Dndley..... 750,000	Silvertown..... 1,000,000	Newcastle, N. S. W..... 200,000	Washington, U.S.A. 2,000,000
Driffield..... 100,000	Bromley..... 2,000,000	Numea, "..... 100,000	Wallasey..... 750,000
Dukenfield..... 500,000	"..... 1,500,000	Namur..... 250,000	Weimar..... 150,000
Dover..... 750,000	"..... 1,500,000	Newark..... 350,000	Wurzen..... 200,000
"..... 1,000,000	"..... 1,500,000	Oldbury..... 500,000	Worcester, U.S.A. 750,000
Deal..... 200,000	"..... 2,000,000	Otley..... 200,000	Yeadon..... 500,000
Derby 1,500,000	"..... 1,500,000	Oswestry..... 250,000	Yeovil..... 250,000

SOLE AGENT FOR WESTERN HEMISPHERE,
GEO. SHEPARD PAGE, 69 WALL STREET, NEW YORK.

THE UNITED GAS IMPROVEMENT CO.

DREXEL BUILDING, PHILADELPHIA.

OFFICERS:

WILLIAM W. GIBBS, President.

GEORGE PHILLER, Vice-President.

SAML T. BODINE, Gen'l Manager.

RANDAL MORGAN, Gen'l Counsel.

EDWARD C. LEE, Sec'y and Treas.

ALEX. C. HUMPHREYS, Gen'l Supt.

WALTON CLARK, Ass't Gen'l Supt.

H. H. EDGERTON, Chem. and Eng'r.

DIRECTORS:

GEORGE PHILLER,

THOMAS DOLAN

HENRY C. GIBSON,

WM. T. CARTER,

WILLIAM G. WARDEN,

SAML T. BODINE.

BUILDERS, LESSEES AND PURCHASERS OF

✻ GAS WORKS. ✻

Orders solicited from Large Cities, Small Towns, Mills, Institutions, from all who want more Light for Less Money.

NATIONAL GAS LIGHT AND FUEL COMPANY,

No. 218 La Salle Street, Chicago.

THE SPRINGER SYSTEM

OF

Fuel and Illuminating Water Gas Works.

REFERENCES.

People's Gas Lt. & Coke Co.. Chicago, Ill.
 Illinois Light, Heat & Power
 Co. Chicago, Ill
 Elgin National Watch Co. . . Elgin, Ill.
 C. R. I. & P. R. R. Shops. . Chicago, Ill.
 Decatur Gas Lt & Coke Co.. Decatur, Ill.
 Niles Gas Light Co. Niles, Mich.
 Newton Illuminating Co. . . Newton, Kansas.
 Wellington Light & Heat Co.. Wellington, Kansas.
 Chippewa Falls Gas Lt. Co.. Chippewa Falls, Wis.
 Elkhart Gas Lt & Coke Co. . Elkhart, Ind.
 Madison City Gas Light Co. Madison, Wis.
 South Bend Gas Light Co. . South Bend, Ind.
 Sheboygan National Gas Co. Sheboygan, Wis.
 Salina Gas Light Co. Salina, Kansas.
 The Rathbun Co. Deseronto, Prov. Ont.
 Jefferson City Gas Lt. Co. . Jefferson City, Mo.
 Mankato Gas Light Co. Mankato, Minn.
 Lima Gas Light Co. Lima, Ohio.

Minneapolis Gas Light and
 Coke Co. Minneapolis, Minn.
 Bellevue Water and Fuel { Bellevue, Campbell
 Gas Light Co. } County, Ky.
 Bucyrus Gas Lt. & Fuel Co. Bucyrus, Ohio.
 Morris Gas Co. Morris, Ill.
 Los Angeles Gas Co. Los Angeles, Cal.
 San Diego Gas Fuel & Elec-
 tric Lt. Co. San Diego, Cal.
 Sioux Falls Gas Co. Sioux Falls, Dak.
 Dakota Gas and Fuel Co. . Grand Forks, Dak.
 St. Johns Mutual Gas Co. . St. Johns, Mich.
 Stillwater Gas Light Co. . . Stillwater, Minn.
 St. Paul Gas Light Co. . . . St. Paul, Minn.
 Emporia Electric and Gas
 Light Co. Emporia, Kas.
 Van Wert Gas Light Co. . . Van Wert, Ohio.
 Lansing Gas Light Co. Lansing, Mich.
 San Francisco Gas Lt. Co. . San Francisco, Cal.

Shelbyville Gas Light Co. . . Shelbyville, Ind.
 Great Falls Gas Light Co. . Great Falls, N. H.
 Belleville Gas Co. Belleville, Ontario
 Rochester Lt. and Fuel Co. . Rochester, Minn.
 Northwestern Gas Light and
 Coke Co. Evanston, Ill.
 Lincoln Gas Light Co. Lincoln, Neb.
 Davenport Gas Light Co. . . Davenport, Iowa.
 Municipal Gas Co. Albany, N. Y.
 Alliance Gas Light Co. Alliance, Ohio.
 New Gas Light Co. Jamesville, Wis.
 Chicago Gas Lt. & Coke Co., Chicago, Ill.
 Joliet Gas Co. Joliet, Ills.
 Superior Light & Fuel Co. . Superior, Wis.
 Kewanee Gas Light Co. . . . Kewanee, Ill.
 Aberdeen Light & Fuel Co. . Aberdeen, So. Dak.
 Pierre Light and Fuel Co. . Pierre, So. Dak.
 *Standard Gas Light Co. . . . New York City.
 *Carlinville Gas Light Co. . Carlinville, Ill.

* Building.

GUARANTEED ESTIMATES of Cost of Gas Furnished on Application.

GASHOLDER TANK CONSTRUCTION, ETC.

Gas Companies and others about to erect Gasholders will find it profitable to consult
 W. C. Whyte, who for over 30 years has made a specialty of

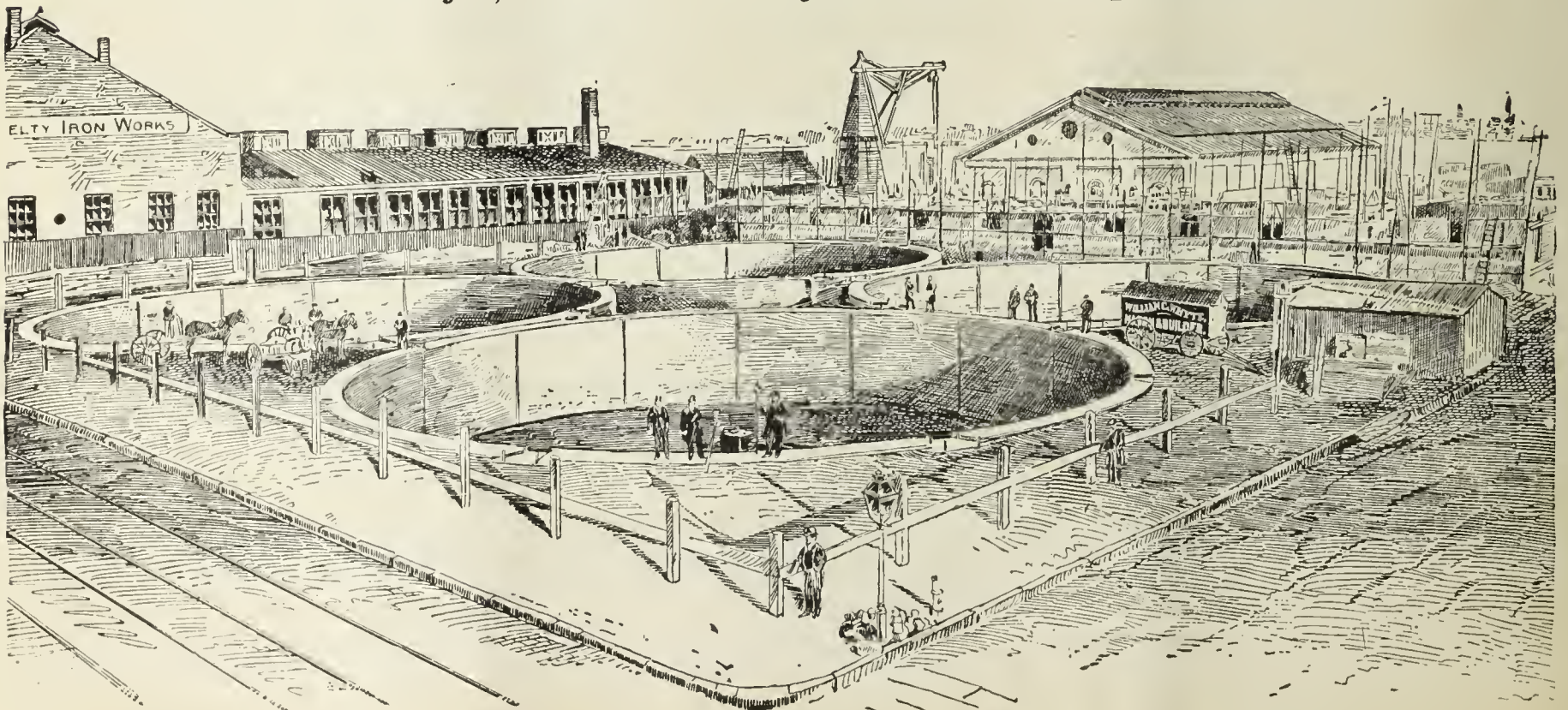

Tank Excavation and Mason Work.

Fifty Tanks now in operation show the sort of work done. Address

W. C. WHYTE, - No. 15 Cortlandt Street, N. Y. City.

CONNELLY & CO.,

SOLE MANUFACTURERS OF THEIR PATENTED SPECIALTIES.

"IRON SPONGE." Saves money, saves labor, and is the most efficient purifying agent ever offered as a substitute for lime. Now used in every State in the Union, and purifying daily over thirty-five million cubic feet. Should be used in every gas works. Its own saving will pay for it many times over.

AUTOMATIC GOVERNOR. Has been on the market but three years, and in that time has been introduced more generally than any invention ever designed for use in gas works. Over two hundred of them now in use. Sensitive; reliable; perfectly automatic; reduces leakage; satisfies consumers, and gives great relief to the Manager. No gas works is complete without one of these machines.

STEAM JET EXHAUSTER. Designed particularly for small works. Combines Exhaust Tube, Steam Governor Gas Compensator, and Bye-Pass Valves in the most compact form possible; occupies but little space; uses very little steam; operated by ordinary workmen; saves formation of carbon in retorts; increases yield 10 to 15 per cent. Specially adapted for mixing air with oil gas. No works too small to use them profitably.

Prices given on all our specialties delivered at any point in the United States. Correspondence solicited.

CONNELLY & CO., No. 111 Broadway, New York City.

WILBRAHAM GAS EXHAUSTER

JARVIS ENGINEERING CO.,

61 Oliver St., Boston, Mass.

CONTRACTORS FOR ERECTING

COMPLETE STEAM OUTFITS FOR ELECTRIC LIGHTING STATIONS.

Steel Boilers set with Jarvis Pat. Boiler Setting

To burn **COKE SCREENINGS** for Fuel.

ARMINGTON & SIMS CO. ENGINES,

Belting direct to Dynamos, without using Shafting.

SEND FOR CIRCULARS.

REFERENCES.—Charlestown Gas & Electric Light Co., Charlestown, Mass.; Schenectady Gas & Electric Light Co., Schenectady N. Y.; Brookline Gas Co., Brookline, Mass.

Practical Electric Lighting

By A. BROMLEY HOLMES, A.M.I.C.E.

With 87 Illustrations. Third Edition. Price, \$1.00.

Electric Light Primer.

By CHARLES L. LEVEY.

A simple and comprehensive Digest of all the most important facts connected with the running of the Dynamo and Electric Lights, with Precautions for Safety, etc.

Price, 50 cents.

A. M. CALLENDER & CO., 42 Pine St., N. Y.

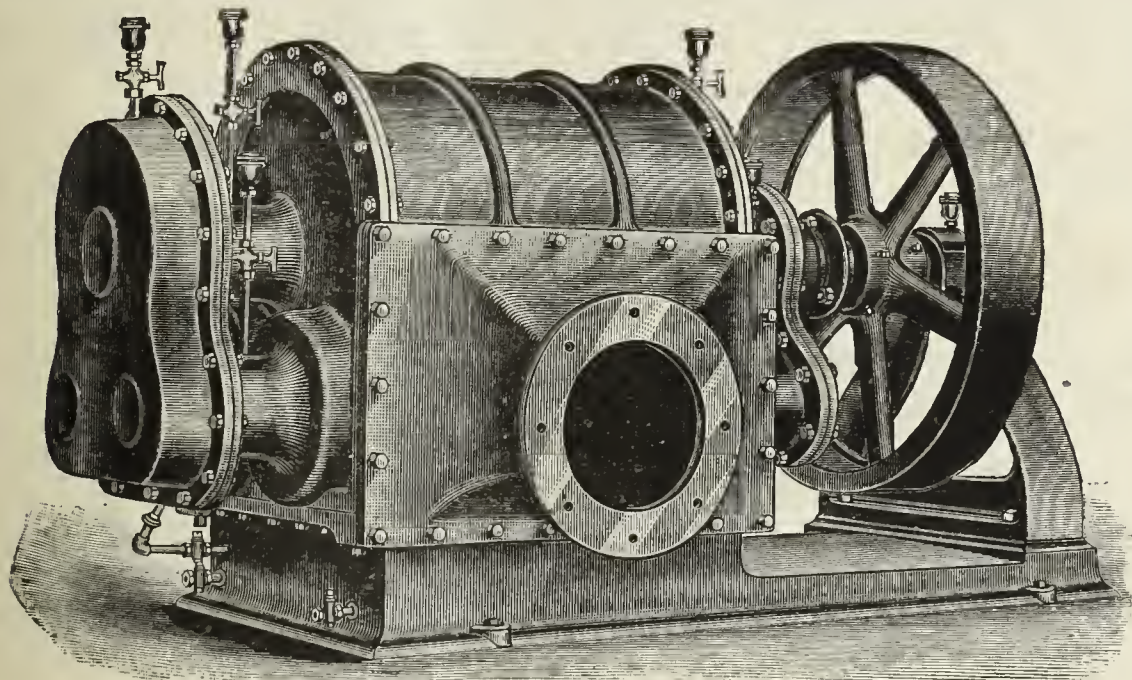

WILBRAHAM BROS.,

PHILADELPHIA, PA.

(Patented.)

IMPORTANT!

(Patented)

NEW SOLVENT FOR GAS PIPE DEPOSITS.

Economical and Effective.

MAAS & WALDSTEIN, 44 Trinity Place and 81 Greenwich St., N. Y.

Gasholder Tanks & Gas Works Masonry Complete.

PLANS PREPARED AND ESTIMATES FURNISHED AT SHORT NOTICE.

J. P. WHITTIER, - - 499 Wythe Av., Brooklyn, N. Y.



CHAPMAN VALVE MANUFACTURING CO.,

MANUFACTURERS OF

Valves and Gates for Gas, Ammonia, Water, Etc.

Also, Gate Fire Hydrants With and Without Independent Nozzle Valve. All Work Guaranteed.

WORKS & GEN'L OFFICE:
Indian Orchard, Mass.

TREASURER'S OFFICE:
72 Kilby & 112 Milk Sts, Boston, Mass.

LUDLOW VALVE MFG. CO.

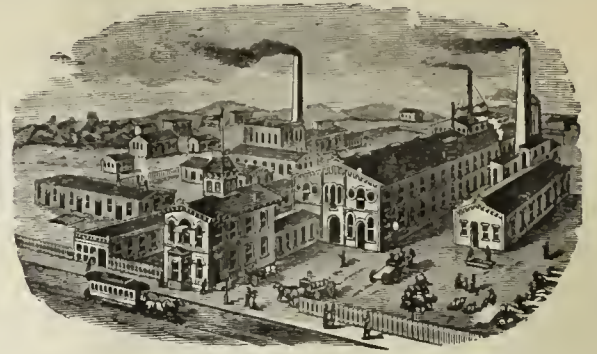

OFFICE AND WORKS,

932 to 954 River Street and 67 to 83 Vail Av.,
TROY, N. Y.

Parson's Steam Blower,

FOR IMPROVING BAD DRAUGHT IN BOILERS, AND FOR BURNING BREEZE OR OTHER WASTE MATERIAL.

PARSON'S TAR BURNER,

FOR UTILIZING COAL TAR AS FUEL.

PARSON'S AIR JET TUBE CLEANER,

FOR CLEANING BOILER TUBES.

These devices are all first-class. They will be sent to any responsible party for trial. No sale unless satisfactory. Manufactured by the WATERTOWN STEAM BLOWER COMPANY.

H. E. PARSON, Supt., 33 & 35 Liberty St., N. Y.

MILLS' REVERSIBLE LIME TRAY,

AND

WOODWORK

Of Every Description

NEEDED BY GAS WORKS.

SEND FOR CIRCULAR AND PRICE LIST TO

BARTLETT, HAYWARD & CO.,

Pratt and Scott Streets, Baltimore, Md.

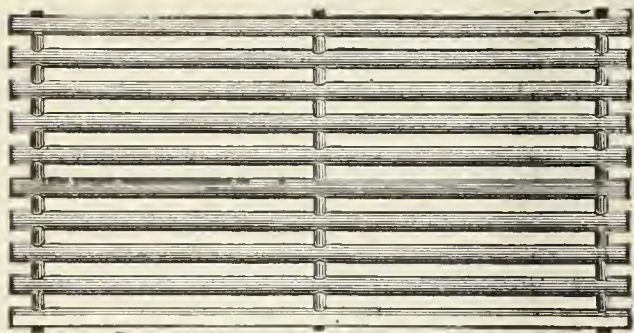

Hydraulic Main Dip Regulators, also Check Valves, Foot Valves, Yard-wash and Fire Hydrants. Send for Circulars.

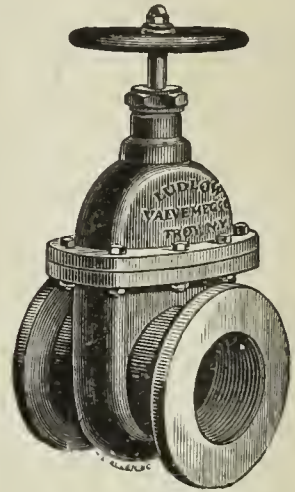

Valves.—Double and Single Gate, 1/2 in. to 48 in., outside and inside Screws. Indicator, etc., for Gas, Water, Steam, and Oil. Send for Circulars.

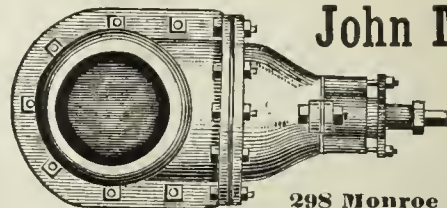

John McLean

Man'facturer

GAS VALVES.

298 Monroe Street, N. Y.

SPECIAL TRAYS FOR IRON SPONGE OR OXIDE OF IRON. CHURCH'S TRAYS A SPECIALTY.

REVERSIBLE-STRONGEST-MOST DURABLE-MOST EASILY REPAIRED.

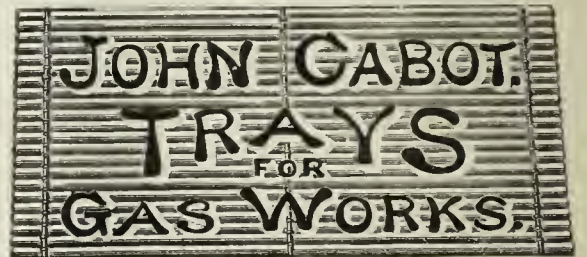

306-310 ELEVENTH AVENUE, NEW YORK.

WE ALSO MAKE THE CHEAPEST AND STRONGEST REVERSIBLE BOLTED TRAYS IN THE MARKET.

VAN DUZEN GAS & GASOLINE ENGINE

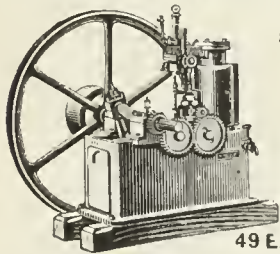

OPERATED with COAL and OTHER MANUFACTURED GASES AND GASOLINE.

RELIABLE AND ECONOMICAL.

Fully Warranted

VAN DUZEN Gas & Gasoline Engine Co. 49 E. 2d St., Cincinnati, O.

A. MacKinnon Machine Co., Agts., 22 Warren St., N. Y.

The Management of Small Gas Works.

BY C. J. R. HUMPHREYS.

Price, \$1.

Orders to be sent to A. M. CALLENDER & CO.,

42 PINE STREET, NEW YORK.

THE CLERK GAS ENGINE CO.,

Main Office, 1012, 1014, 1016, 1018 Filbert St., Philadelphia, Pa.

WM. W. GOODWIN, Prest.

E. STEIN, Sec.

S. LEWIS JONES, Asst. Sec.

A. J. DOTY, Supt.

The utility and convenience of the Gas Engine being no longer an open question, it only remains now for intending purchasers to select the BEST. We claim for the CLERK GAS ENGINE that it is equal to any other manufactured as regards steadiness in running, simplicity, and ease of keeping in repair, and that it gives the greatest amount of power for the least money (both in first cost and expense of running) of any engine made. In support of this claim we refer to the test of the Gas Engines made under the direction of the American Institute of New York, in December, 1885, and heretofore published in these columns. These engines are especially adapted for continuous running under heavy loads, and we can refer to Engines which have run 22 hours a day for months at a time

Made in Sizes of 5 10 15 20, and 25 Horse Power. All Engines Guaranteed for One Year.

GAS STOVES.

GAS METERS.

GAS STOVES.

THE AMERICAN METER CO.,

MANUFACTURERS OF

GAS METERS, Station Meters,

METER PROVERS, PHOTOMETERS,

PRESSURE GAUGES OF ALL KINDS,

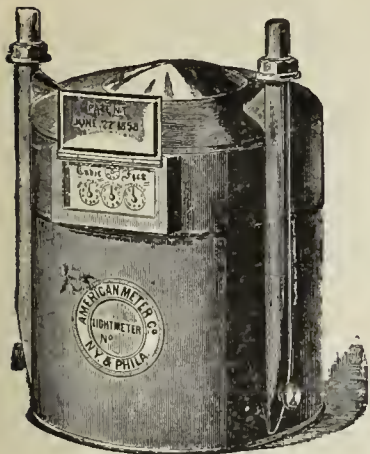

Standard 3 Diaphragm Dry Meter



Standard 2 Diaphragm Dry Meter.

AND

Apparatus for Testing the Quantity and Quality of Gases.

GAS STOVES FOR HEATING AND COOKING

Sole Agents in the United States for

Verity's Patent Gas Fires.

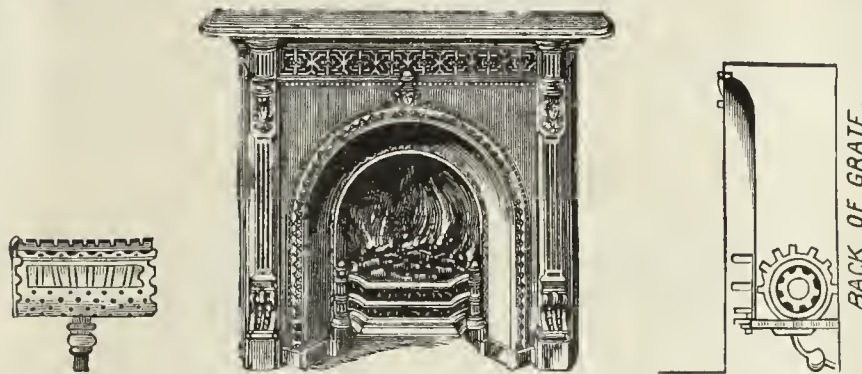

Circulars and Price Lists on Application.

MANUFACTORIES,

508 to 514 West Twenty-second St., N. Y.

Arch and Twenty-second St., Phila

Nos. 244 & 246 North Wells Street, Chicago, Ill.

AGENCIES,

No. 177 Elm Street, Cincinnati, Ohio.

No. 222 Sutter Street, San Francisco, Ca!

No. 810 North Second Street, St. Louis, Mo.

GAS STOVE SHOW ROOMS, No 242 Sixth Avenue, New York City.

RETORTS AND FIRE BRICK.

J. H. CAUTIER & CO.,
CORNER OF
GREENE AND ESSEX STREETS,
JERSEY CITY, N. J.

MANUFACTURERS OF
**Clay Gas Retorts,
Gas House Tiles,
Fire Bricks, Etc. Etc.**

Ground Clay, Fire Brick and
Fire Sand in Barrels,

J. H. GAUTIER. C. E. GREGORY. C. E. GAUTIER.

BROOKLYN
Clay Retort & Fire Brick Works,
(EDWARD D. WHITE & CO.)

Manufacturers of Clay Retorts, Fire Brick,
Gas House and other Tile.

VAN DYKE, ELIZABETH, RICHARDS & PARTITION STS.
Office, 88 Van Dyke St., Brooklyn, N. Y.

RETORTS AND FIRE BRICK.

LACLEDE FIRE BRICK MFG. CO.,
MANUFACTURERS OF

Fire Brick, Gas Retorts,

AND

ST. LOUIS STANDARD SEWER PIPE.

Blast Furnace and Cupola Linings, every description of Fire
Clay Material, Fire Clay Flue Linings, Chimney Tops
Dry Milled and Crude Fire Clays, etc.

OFFICE AND DEPOT

901, 903, and 905 Pine Street,
ST. LOUIS, MO.

ESTABLISHED IN 1845.

B. KREISCHER & SONS,

OFFICE FOOT OF HOUSTON ST., E. R., N. Y.

Gas Retorts,

TILES, FIRE BRICK.

AND EVERYTHING IN THE FIRE CLAY LINE.

RETORTS AND FIRE BRICK.

MANHATTAN

FIRE BRICK & ENAMELLED CLAY

RETORT WORKS

ADAM WEBER.

**CLAY GAS RETORTS
AND RETORT SETTINGS
FIRE BRICKS, TILES, ETC.,**

Office and Works, 15th Street and Avenue C., N. Y.



Works,
LOCKPORT STATION, PA.

—ESTABLISHED 1864.—

JAMES GARDNER, JR.,

Office, Rooms 19 & 20, Lewis Block,
PITTSBURGH, PA. P. O. Box 373.

Successor to WILLIAM GARDNER & SON.

Fire Clay Goods for Gas Works.

H. A. NORTON, No. 4 CENTRAL STREET, BOSTON, MASS., Agent for the New England States.

GEO. C. HICKS, Prest. **CHICAGO** CHAS. A. REED, Sec. & Treas.

Retort and Fire Brick Co.,

MANUFACTURERS OF

Fire Clay Goods of all Kinds,

AND BEST QUALITY ONLY.

Regenerative Furnaces & Water Gas Goods.

45th St., Clark to La Salle, Chicago.

GEROULD'S IMPROVED RETORT CEMENT.

A Cement for patching retorts, putting on mouthpieces, and
making up all bench-work joints. This Cement is mixed ready
or use. Economic and thorough in its work. Fully warranted
o stick. For recommendations and price list address

C. L. GEROULD & CO.,

5 & 7 Skillman St., Brooklyn, N. Y.

Western Agent, H. T. GEROULD, Mendota, Ill.

**Parker-Russell
Mining and Mfg. Co.,**

CITY OFFICE: { Me mod-Jaccard Bldg., Focms 307 & 308,
Broadway and Locust Street, St. Louis, Mo.

PROPRIETORS OF THE

OAKHILL GAS RETORT & FIRE BRICK W'KS

Our immense establishment is now employed almost entirely in
the manufacture of materials for

GAS COMPANIES.

We have studied and perfected three important points. Our re-
torts are made to stand changes of temperature, the strongest
heats of the furnace, and the abrasion of feeding and emptying.

We furnish and build Half-Depth or Full
REGENERATOR FURNACES
of different kinds and most approved styles.

Correspondence solicited.

THOS. SMITH, Prest. AUGUST LAMBLA, Vice-Prest. & Supt.

BALTIMORE

RETORT & FIRE BRICK CO.

MANUFACTORY AT

LOCUST POINT, BALTIMORE, MD.

**Clay Retorts, Blocks & Tiles,
FIRE BRICK, FIRE CLAY,
AND FIRE CEMENT.**

Red and Buff Ornamental Tiles and Chim-
ney Tops. Drain and Sewer Pipe (from
2 to 30 inches). Baker Oven Tiles
12x12x2 and 10x10x2.

WALDO BROS., 88 WATER ST., BOSTON, MASS

Sole Agents the New England States.

1889 DIRECTORY 1889

OF THE GAS LIGHT COMPANIES of the UNITED STATES & CANADA.

Price, \$3.00.

A. M. CALLENDER & CO., No. 42 Pine Street, N. Y. City.

HENRY MAURER & SON,

(ESTABLISHED 1856.)

**EXCELSIOR FIRE BRICK & CLAY
RETORT WORKS**

WORKS, Perth Amboy, N. J.
OFFICE, 418 to 422 East 23d St., N. Y.

**Clay Gas Retorts,
BENCH SETTINGS,
Fire Brick, Tiles, Etc.**

**FLEMMING'S
Generator-Gas Furnace**

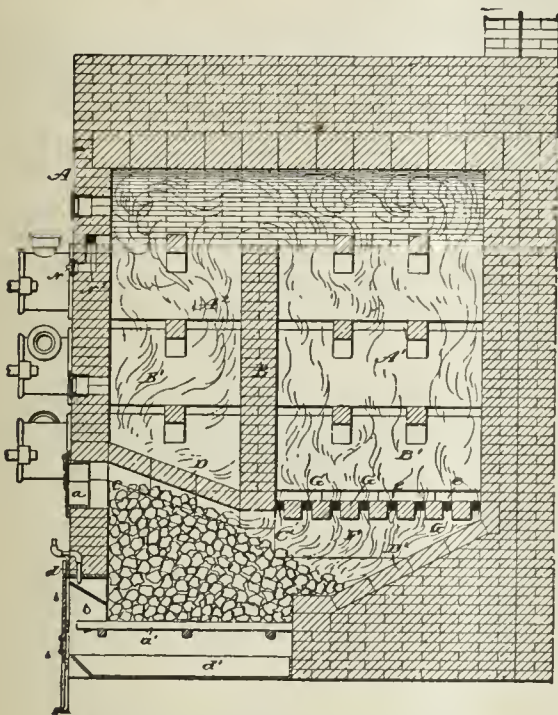

Materials furnished and Benches erected by

J. H. GAUTIER & CO., - Jersey City, N. J.

Address as above, or D. D. FLEMMING, Jersey City, N. J.

FRED. BREDEL,

CONTRACTOR FOR THE COMPLETE

Erection and Equipment of Gas Works.

SOLE PROPRIETOR OF THE

KLOENNE PATENTS

FOR NORTH AMERICA.

REGENERATIVE FURNACES.

(900 Retorts are now fired in America by the Kloenne-Bredel System.)

SELF-SEALING MOUTHPIECES.

(Over 800 Now in Use.)

Standard Condensers. Washer-Scrubbers.

TAR WASHERS FOR WATER GAS PLANTS.

(In use in the works of the Chicago Gas Lt. Co.)

GASHOLDERS.

Bredel's Automatic Gas Governor.

Refers, by permission, to Mr. Eugene Vanderpool, Newark, N. J.; Mr E. G. Cowdery, Milwaukee, Wis.; and Mr. Theo. Forstall, Chicago, Ills. For further information, address

FRED. BREDEL,

No. 208 East Seventeenth Street, N. Y. City.

HENRY PRATT & CO.,

BUILDERS OF THE

PRATT & RYAN WATER GAS GENERATORS,

Arranged to Use Either Crude Oil or Naphtha.

Condensers, Scrubbers, Purifiers, and all Apparatus for Coal or Water Gas.

IRON ROOFS, BOILERS, TANKS, ETC.

Orders and Correspondence Solicited.

Plans and Estimates Furnished for New Works or for the Alteration of Old Works.

Office and Works, 869 to 875 So. Halsted St. CHICAGO, ILL.

COMPOUND Condensing or Non-Condensing.

16 SIZES, 5 to 500 H. P.

Not yet equaled by any form of Engine for **HIGH FUEL DUTY AND SIMPLICITY.**

STANDARD 13 Sizes in Stock. 5 to 250 H. P.

3000 in use in all parts of the Civilized World.

JUNIOR 6 Sizes in Stock, 5 to 50 H. P.

An Automatic Engine cheaper than a Slide Valve. WELL BUILT. ECONOMICAL. RELIABLE.

Over 300 Sold the First Year.

All the above built strictly to Gauge with INTERCHANGEABLE PARTS.

REPAIRS CARRIED IN STOCK.

SEND FOR ILLUSTRATED CATALOGUES.

**WESTINGHOUSE
ENGINES**
The Westinghouse Machine Co.
PITTSBURGH, PA. U.S.A.

SELLING DEPARTMENT IN THE UNITED STATES.

New York, 47 Cortlandt St. } Westinghouse,
Boston, Hathaway Building, } Church, Kerr
Pittsburgh, Westinghouse Build'g, } & Co.
Chicago, 156, 158 Lake St.
Philadelphia, 608 Chestnut St. M. R. Muckle, Jr. & Co.

ST. LOUIS,

511 NORTH FOURTH ST.,

Westinghouse, Church, Kerr & Co.

Salt Lake City, 259 S. Main St. } Utah & Montana
Butte, Mont. L. Granite St. } Machinery Co.
San Francisco, 21, 23 Fremont Street, Parke & Lacy Co.
Portland, Or. 33, 35 N. Front St. Parke & Lacy Mech. Co.
Charlotte, N. C. 36 College St. } The D. A. Tompkins Co.
Atlanta, Ga. 45 S. Prior St. }
Dallas, Tex. Keating Imp. & Machine Co.
Chattanooga, Tenn., C. E. James & Co.

GAS AND WATER PIPES.

GAS AND WATER PIPES.

ENGINEERS.

SAM'L R. SHIPLEY, Pres.
HENRY B. CHEW, Tre.

JAS. P. MICHELLON, Sec.
WM. SEXTON, Supt.

P. D. WANNER, Chairman. A. H. MELLERT, Mangr. of Wks.
R. B. KINSEY, Secretary. F. A. KNOPP, Treasurer.

GLOUCESTER IRON WORKS,
GLOUCESTER CITY, N. J.



Cast Iron Gas & Water Pipes, Stop Valves, Fire Hydrants, Gasholders. &c.

Office, Rooms 61 and 63 Bullitt Building, 131 S. 4th St., Phila., Pa.

WARREN FOUNDRY AND MACHINE CO.,

Established 1856. Works at Phillipsburgh, N. J.

New York Office, 160 Broadway.

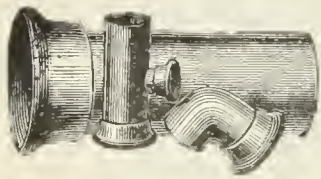

CAST IRON WATER AND GAS PIPE,

FROM TWO TO FORTY-EIGHT INCHES DIAMETER. ALSO, ALL SIZES OF

Flange Pipe for Sugar House and Mine Work. Branches, Bends, Retorts, etc., etc.

DENNIS LONG & COMPANY,

LOUISVILLE, KY.,



Manufacture Exclusively

CAST IRON GAS & WATER PIPE & SPECIAL CASTINGS
OF ALL SIZES.

King's Treatise on Coal Gas.

A standard text-book for the Engineers and Managers of Gas Works, and for all who are concerned or take an interest in the manufacture and distribution of Coal Gas, and in the utilization of the Secondary Products resulting therefrom; treating also of the Gas Engine, and of Gas Cooking and Heating Appliances.

In 3 Vols. Price per Vol., \$10. Sold either by Volume or in Sets.

A M. CALLENDER & CO., 42 Pine St., N. Y.

MELLERT FOUNDRY & MACHINE CO. Ltd.
and **READING FOUNDRY CO., Ltd.**
Reading, Pa.



Specials—Flange Pipe, Valves and Hydrants
Lamp Posts, Retorts, etc.

General Foundry and Machine Work.

JOHN FOX, Selling Agent. 160 Broadway, N. Y.

THE OHIO PIPE COMPANY,

MANUFACTURERS OF

Cast Iron Gas & Water Pipe,

BRANCH AND SPECIAL CASTINGS.

Gas-House Bench Castings, Hydraulics, Lamp Posts, Flange Pipe
and Specials, Architectural Castings, Building Columns,
Joists, Cellar Grates, Sash Weights, etc.

GENERAL FOUNDERS AND MACHINISTS.

Columbus, Ohio.

M. J. DRUMMOND,



SPECIAL CASTINGS AND LAMP POSTS.

Office, Corbin Building, 192 Broadway, N. Y.

EMAUS PIPE FOUNDRY.

DONALDSON IRON COMPANY. EMAUS, PA.



MANUFACTURERS OF

CAST IRON PIPE AND SPECIAL CASTINGS
FOR WATER AND GAS.

JOS. R. THOMAS,

No. 42 Pine Street, N. Y. City.

CONSULTING AND CONSTRUCTING

Gas Engineer and Contractor.

PLANS, SPECIFICATIONS, AND ESTIMATES
FURNISHED.

Contracts taken for all Appliances
required at a Gas Works,

Either for New Works or Extensions to Old Plants.

WM. MOONEY

(Successor to WM. FARMER)

No. 94 Liberty St., N. Y. City.

GAS ENGINEER AND CONTRACTOR FOR THE ERECTION
OF GAS WORKS, OR APPARATUS OF ANY
CAPACITY.

Plans and Specifications Furnished.

WM. GARDNER,
Gas Engineer,

Lewis Block, Room 20, Pittsburgh, Pa.

Those who intend to make alterations in existing gas plants, or who contemplate the erection of new works, will find it to their interest to open correspondence with the above. Plans made and estimates furnished.

BARTLETT, HAYWARD & CO.

Baltimore, Md.

Triple Double, & Single-Lift
GASHOLDERS.

Iron Holder Tanks.

ROOF FRAMES.

Cirders.

BEAMS.

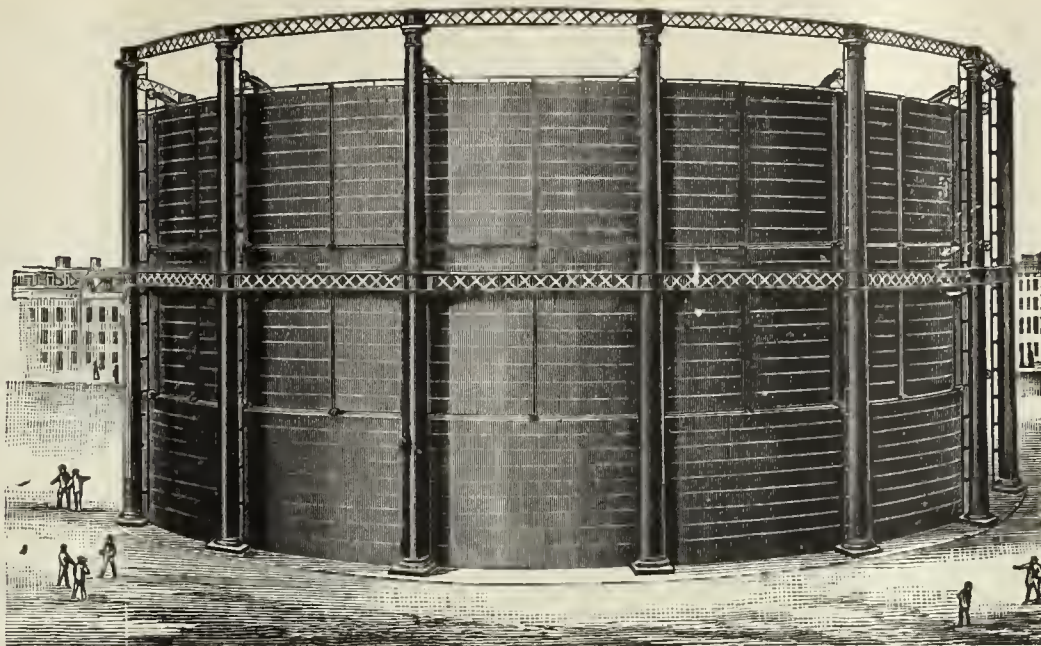

PURIFIERS.

CONDENSERS.

Scrubbers.

BENCH CASTINGS.

OIL STORAGE TANKS.

Boilers.

The Wilkinson Water Gas Process.

THIRTY-CANDLE, NON-CONDENSABLE, FIXED GAS. THE MOST SUCCESSFUL GAS PROCESS IN OPERATION.

Munich Regenerative Furnace, System Drs. Schilling & Bunte.

HAZELTON BOILERS.

Gas Works Designed and Constructed.

Pascal Iron Works. ESTABLISHED 1821. Delaware Iron Works.

MORRIS, TASKER & CO.,

INCORPORATED.

OFFICE, 224 SOUTH THIRD STREET, - - PHILADELPHIA, PA.

CONTRACTORS, BUILDERS, AND MANUFACTURERS OF

Gas, Water & Sugar Works

Bench Castings.

Condensers.

Scrubbers.

Purifiers.

Hyd. Carriages.

Iron Floors,

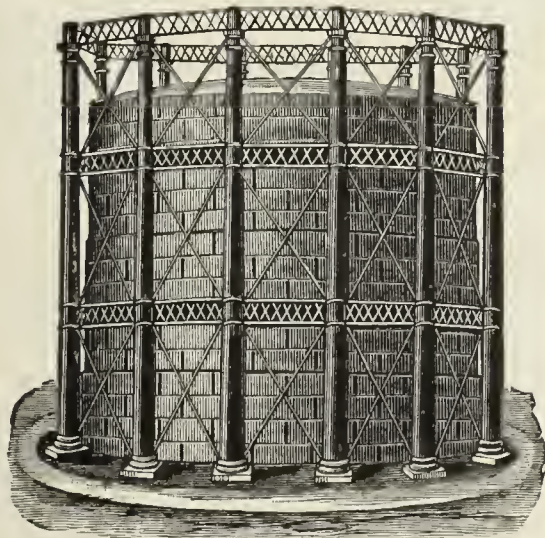

Iron Roofs.

Street Stops,

Valves, etc.

Stand-Pipes.

Water & Oil

Tanks, all Sizes.

Single, Double, and Triple-Lift Gas Holders.

SELF-SEALING RETORT LIDS. STAMPED STEEL RETORT LIDS.

Locomotive Water Columns, Filters, etc. Boiler Tubes, Wrought Iron Pipe & Fittings

Plans, Specifications and Estimates for all kinds of Machinery furnished on application.

Foundries & Works,
MILLVILLE, FLORENCE,
and CAMDEN, N. J.

R. D. WOOD & CO.,

Engineers,
Iron Founders,
and
Machinists.

400 Chestnut St., PHILADELPHIA, PA.

MANUFACTURERS OF

CAST IRON PIPE,

Gas Holders,

SINGLE, DOUBLE, AND TRIPLE LIFTS, WITH
OR WITHOUT WROUGHT IRON
OR STEEL TANKS.

PURIFIERS, CONDENSERS.

Scrubbers.

BENCH WORK.

Iron Floors and Roofs, Plate Girders.

Heavy Loam Castings.

HYDRAULIC WORK.

Lamp Posts, Valves, Etc.

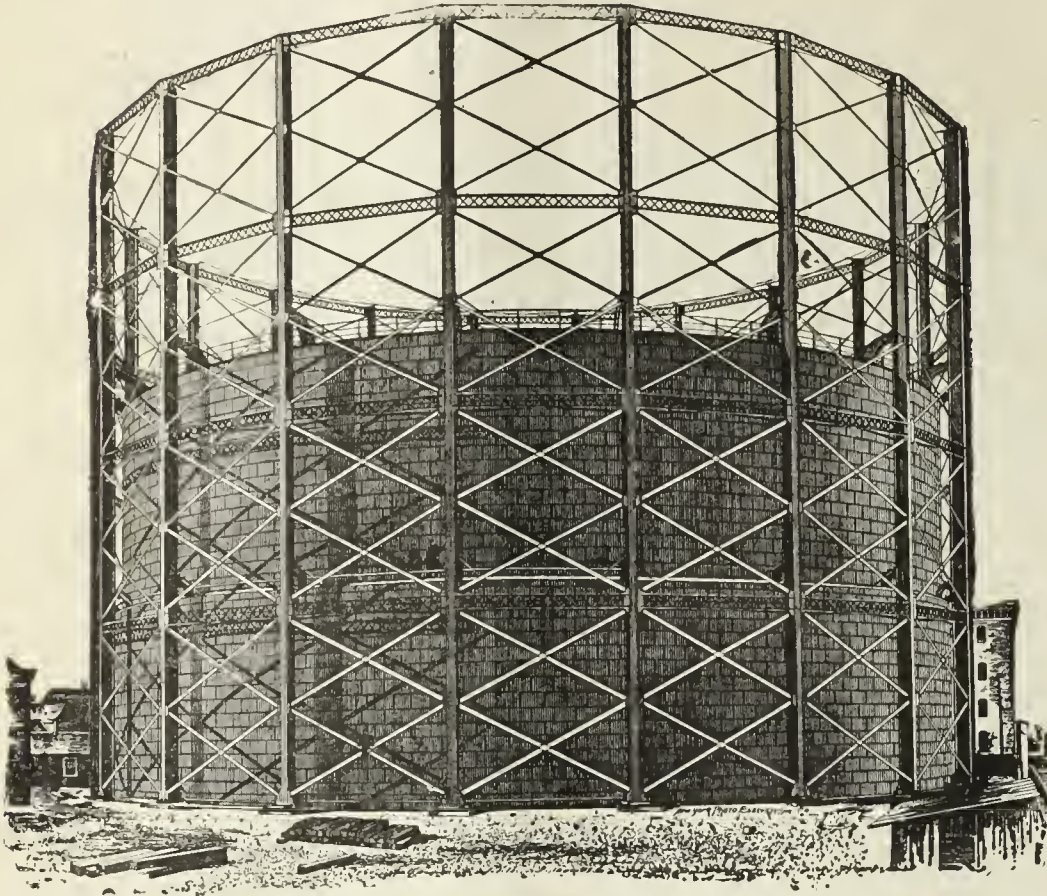

SMITH & SAYRE MFG. COMPANY,

G. G. PORTER, Prest.

245 Broadway, N. Y.

CHAS. W. ISBELL, Sec'y.

Machinery & Apparatus for Gas Works

Drawings, Plans, and Estimates Furnished for the Improvement, Extension, or Alteration of Gas Works, or for the Construction of New Works.

Mackenzie's Patent Rotary and Steam Jet Gas Exhausters, Governors, Compensators, Condensers, Washers, Scrubbers. Isbell's Patent Automatic Street Pressure Governor, Gas and Water Valves, Hydraulic Main Dip Regulator, Bench Castings, etc. Purifying Boxes and "Standard" Scrubbers. Isbell's Patent Self-Sealing Retort Doors.

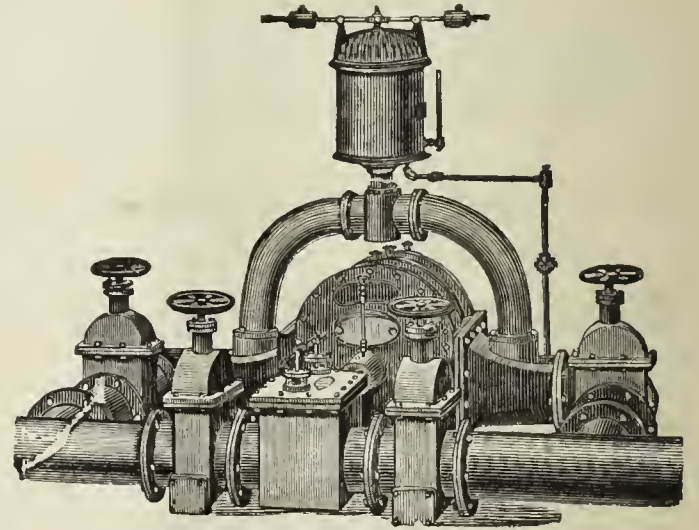

THE BRENNER SELF-SEALING RETORT DOOR. Simple, Strong, and Durable.

CLOSES ABSOLUTELY TIGHT & IS LOCKED BY A CAM LEVER. ALL NECESSARY ADJUSTMENT FOR WEAR PROVIDED.

BUILT BY

SMITH & SAYRE MFG. CO.,
No. 245 Broadway, - - - New York City.

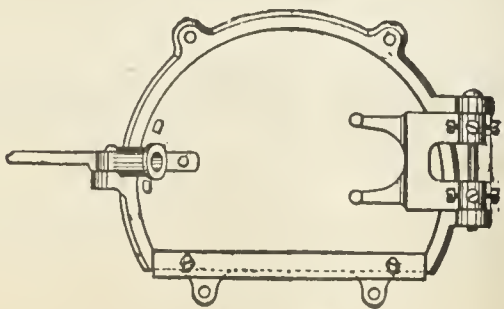

Brenner Self-Sealing Retort Door.

WILLIAM B. LUNDIE, Superintendent of the 42d Street Station of the Consolidated Gas Company, of New York, writes, under date of Jan. 4, 1889:

"We have 320 Brenner Self-Sealing Lids in use at this Station, built by the Smith & Sayre Mfg. Co. They require very little attention, and are the best of the kind that I have seen, giving entire satisfaction."

GAS WORKS APPARATUS AND CONSTRUCTION.

GAS WORKS APPARATUS AND CONSTRUCTION.

JAMES R. FLOYD & SONS,

(SUCCESSORS TO HERRING & FLOYD)

Oregon Iron Works,

W. 20th & 21st. Sts., bet. 10th & 11th Aves.,
NEW YORK CITY.

Engineers and Contractors

FOR THE

**CONSTRUCTION OF
GAS WORKS.**

MANUFACTURERS OF

All Kinds of Castings and
General Ironwork

FOR

GAS APPARATUS.

Bench Castings, Regenerative and Half
Regenerative Furnace Castings.

Condensers, Scrubbers, Purifiers,
Street Drips and Connections,

Valves,

Hydraulic Hoisting Purifier Carriage,
Self-Sealing Retort Lids, Improved
Valve Stand and Indicator,
Seller's Cement.

Plans, Specifications, and Estimates furnished for Construction
of New or Alteration of Old Works.

CONTINENTAL IRON WORKS.

THOS. F. ROWLAND, Prest.

WARREN E. HILL and CHAS. H. CORBETT, V-Prests.

THOS. F. ROWLAND, JR., Sec. & Tr

P. O. Station G., BROOKLYN, N. Y.

ENGINEERS AND MANUFACTURERS OF

Gas Holders

CONDENSERS, SCRUBBERS, VALVES,

PURIFIERS, SELF-SEALING RETORT LIDS

Hydraulic Mains,

And all other articles connected with the man-
ufacture and distribution of Gas.



H. RANSHAW, Prest. & Mangr.

WM. STACEY, Vice-Prest.

T. H. BIRCH, Asst. Mangr.

R. J. TARVIN, Sec. & Treas.

STACEY MFG. CO.,

MANUFACTURERS OF.

Single and Telescopic Gasholders,

IRON ROOFS, BRIDGES, LAMP POSTS,

Water and Oil Tanks, Coal Elevator Cars,

COKE CRUSHERS, BENCH CASTINGS,

And all kinds of Wrought and Cast Iron Work used in the erection of Coal and Oil Gas Works
Rolling Mill Machinery and Heavy Castings a Specialty.

Foundry:

33, 35, 37 & 39 Mill Street.

Wrought Iron Works:

16, 18, 20, 22, 24 & 26 Ramsey Street:

Cincinnati, Ohio.

Bouton Foundry Co.,

FOUNDERS AND MACHINISTS,

CHICAGO, ILL.

Gas Works Apparatus,

PURIFIERS, CONDENSERS,

Bench Work

SPECIALS, LAMP POSTS,

SCRUBBERS,

Iron Roofs and Floors.

Plans and Estimates furnished for new works or extensions of
old works.

1842. **DEILY & FOWLER,** 1889.

Laurel Iron Works.

Address, No. 39 Laurel Street, Philadelphia, Pa.

BUILDERS OF

GASHOLDERS,

Single and Telescopic.

HOLDERS BUILT 1884 to 1888, Inclusive:

- | | | | | |
|----------------------------|-----------------------------|---------------------------|--------------------------|------------------------|
| Newport, R. I. | Long Island City, N. Y. | Port Chester, N. Y. | Malden, Mass. | West Chester, Pa. (2d) |
| Portland, Oregon. | Macon, Ga. | New Rochelle, N. Y. | Paducah, Ky. | Lancaster, Pa. (3d) |
| Allegheny, Pa. (2d.) | York, Pa. | Salem, N. J. (3d) | Norwich, Conn. | Faony, Pa. (two) |
| Atlanta, Ga. (2d.) | Chester, Pa. | Omaha, Neb. (2d) | Seattle, W. T. | Mount Vernon, N. Y. |
| N.Y. City (Central Gas Co) | Hazleton, Pa. (2d.) | Lynn, Mass. (2d) | San Diego, Cal. | Binghamton, N. Y. |
| Lynchburg, Va. (2d.) | Staten Island, N. Y. | Little Rock, Ark. | Northern Gas Lt. Co., of | Concord, N. H. |
| Saylesville, R. I. | Saugerties, N. Y. | Irrington, N. Y. | New York, N. Y. | Dover, Del. (2d) |
| Rondout, N. Y. | Clinton, Mass. (Lan. Mills) | South Boston, Mass. | Westerly, R. I. | Calais, Me. |
| Atlantic City, N. J. | Chatanooga, Tenn. | Rye, N. Y. (2) | Willimantic, Conn | New London, Conn. (2d) |
| Augusta, Ga. | Galveston, Texas. (3d.) | Woodstock, Ont. | Montclair, N. J. | West Chester, N. Y. |
| Waltham, Mass. (2) | Omaha, Neb. | Malden, Mass. | Attleboro, Mass. | Bay Shore, L. I. |
| Mahanoy City, Pa. | Fort Plain, N. Y. | Staten Island, N. Y. (2d) | Santa Cruz, Cal. | Washington, D. C. |
| New Castle, Pa. | Brunswick, Ga. | Woodstock, Ont. | Erie, Pa. (2d) | |

WM. HENRY WHITE,

No. 32 Pine Street, - - - New York City.

ENGINEER AND CONTRACTOR FOR THE

Erection and Extension of Gas, Water, and Electric Light Works.

SOLE REPRESENTATIVE OF THE

McILHENNY REGENERATOR FURNACE PATENTS

And the Martin Water Gas Process.

Edison Incandescent and American Arc Electric Light Plants Installed.

Correspondence with Gas Companies contemplating extending or improving their Plants respectfully invited.
Plans and Estimates Furnished.

GAS COALS.

CANNEL COALS.

GAS ENRICHERS.

JAMES D. PERKINS. **PERKINS & CO.,** F. SEAVERNES.
228 & 229 Produce Exchange, New York.

Cable Address, "PERKINS, NEW YORK."

Post Office Box 3895, New York.

GENERAL SALES AGENTS FOR

The Youghioghenny River Coal Company's

OCEAN MINE YOUGHIOGHENY GAS COAL.

HON. W. L. SCOTT, Prest. M. H. TAYLOR, Vice-Prest.

This Colliery is located at SCOTT HAVEN, PA., in the center of the Youghioghenny Gas Coal District, and produces the ONLY RELIABLE YOUGHIOGHENY COAL for gas purposes. (See Map on p. 87 of this JOURNAL, Feb. 16, '85.)

POINTS OF SHIPMENT,

Locust Point, BALTIMORE.

Pier No. 62, PHILADELPHIA.

Also, SOLE AGENTS for the

**BRECKENRIDGE CANNEL,
OF KENTUCKY.**

Within the past two years we have delivered this Cannel to over ONE HUNDRED COMPANIES IN THIRTY-THREE DIFFERENT STATES, and it is now in use in some of the large Gas Works

On the Continent and in South America,

where it successfully competes with the Australian Shale. It is the ONLY AMERICAN GAS CANNEL of sufficiently high grade to warrant EXPORTATION TO EUROPE AND SOUTH AMERICA, and it is the only economical substitute for OIL OR NAPHTHA. ONE GROSS TON will produce

10,000 Cubic Feet of 75 Candle Gas,	} equal to {	750,000 Candle Feet of Gas, and 26 Bushels of merchantable Coke weighing 900 Pounds
or 12,500 " " 60 " "		
or 15,000 " " 50 " "		

This is the ONLY GAS CANNEL that will produce a REALLY MERCHANTABLE COKE. It can be delivered in parcels of one carload or more to any point in the United States or Canada. Cargo shipments of any size required can be made from NEW YORK, PHILADELPHIA, BALTIMORE, or NEWPORT NEWS. Samples will be sent and particulars of price, etc., forwarded upon application to above address.

JAMES & WILLIAM WOOD,
Gas and Cannel Coal Contractors,

No. 40 St. Enoch Sq., Glasgow. No. 2 Talbot Court, London.

Proprietors of the BATHVILLE COLLIERIES (which produce the celebrated BOGHEAD CANNEL), Shields, Shieldmuir, Drumpeller, and other Collieries. This Firm offer

STANDARD CANNELS,

Unequaled as Gas Enrichers.

Also, WEST FAIRMONT GAS COAL, of W. Va.

Analyses, prices, and all further information furnished on application to

Agency for U. S., Room 93, Nos. 2 & 4 Stone St., N.Y. City.

The Standard Oil Company,

REFINERS OF

NAPHTHA AND GASOLINES.

ALSO MANUFACTURERS OF

A Special Grade of Naptha for Gas Companies

FOR ENRICHING COAL GAS.

Correspondence solicited.

No. 43 Euclid Avenue, Cleveland, Ohio.

To Gas Companies.

We make to order CAP BURNERS to burn any amount under a stated pressure. Send for samples.

Also, SERVICE CLEANERS, DRIP PUMPS, and STREET MAIN PROVING APPARATUS.

C. A. GEFROER,

248 N 8th Street, Phila., Pa.

COKE CRUSHERS.

GAS COALS.

GAS COALS.

Newburgh Orrel Coal and Coke Co.

MINERS AND SHIPPERS OF

STEAM, SMITHING, AND GAS COALS,
Foundry and Crushed Coke.

Home Office, 33 S. Gay Street, Baltimore, Md.

J. HARRY LEE, President.

Shipping Wharves, Locust Point, Baltimore.

The Despard Gas Coal Co.,

MINERS AND SHIPPERS OF

DESPARD GAS COAL,

AND MANUFACTURERS OF

COKE.

MINES, Clarksburg, Harrison Co., W. Va.

WHARVES, Locust Point, Baltimore, Md.

OFFICE, 225 E. German St., " "

ROUSSEL & HICKS, } AGENTS. } BANGS & HORTON,
71 Broadway, N. Y. } 60 Congress St., Boston.

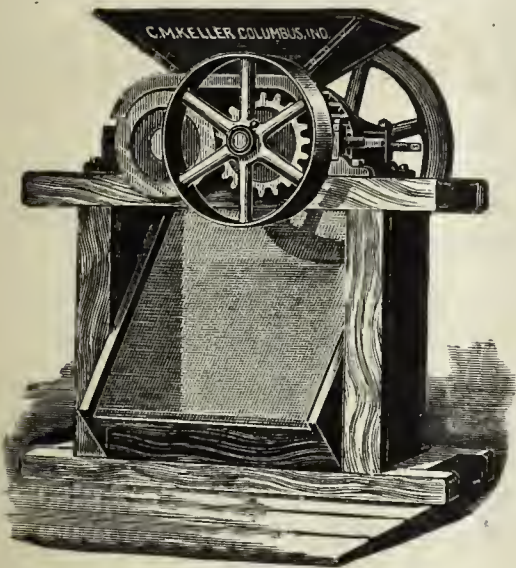

Keller's Adjustable Coke Crusher.

SIMPLE, STRONG, AND DURABLE.

C. M. Keller, Sec. & Supt. Gas Lt. & Coke Co. Columbus, Ind.

Correspondence Solicited.

King's Treatise on Coal Gas.

The most complete work on Coal Gas ever published.

Three Vols. Bound, \$30.

BOOKS.

DISTILLATION OF COAL TAR AND
AMMONIACAL LIQUOR.

By GEORGE LUNGE. Price \$12.50.

A TREATISE ON THE COMPARATIVE
COMMERCIAL VALUES OF GAS
COALS AND CANNELS.

By DAVID A. GRAHAM. 8vo., Cloth. Price \$3.

Orders for these books may be sent to this office.

A. M. CALLENDER & CO.,

42 PINE ST., N. Y. CITY

THE
PENN GAS COAL CO.

OFFER THEIR

Coal, Carefully Screened & Prepared for Gas Purposes.

Their Property is located in the Youghiogheny Coal Basin, near Irwin and Penn Stations on the Pennsylvania Railroad, and on the Youghiogheny River.

Principal Office:

209 SOUTH THIRD STREET, PHILA., PA.

Points of Shipment:

Pennsylvania Railroad Piers; Greenwich Wharves, Delaware River; Pier No. 1 (Lower Side), South Amboy, N. J.

Chesapeake & Ohio Railway Coal Agency,

FOR THE SALE OF THE

Superior Kanawha Gas Coals, Cannelton Cannel,
Also, SPLINT AND STEAM COALS,

From the Kanawha and New River Regions, on the line of the Chesapeake & Ohio R'way.

C. B. ORCUTT, General Agent, - - No. 1 Broadway (Room 217) New York City.

FRANCIS H. JACKSON, Prest. EDMUND H. MCCULLOUGH, V.-Prest. CHAS. F. GODSHALL, Treas. H. C. ADAMS, Sec.

THE WESTMORELAND COAL CO.

Chartered 1854.

Mines situated on the Pennsylvania and the Baltimore and Ohio Railroads, in Westmoreland County, Penn.

POINTS OF SHIPMENT:

PHILADELPHIA, BALTIMORE, SOUTH AMBOY, N. J.,
WATKINS (SENECA LAKE), N. Y.

Since the commencement of operations by this Company its well-known Coal has been largely used by the Gas Companies of New England and the Middle States, and its character is established as having no superior in gas-giving qualities, and in freedom from sulphur and other impurities.

Principal Office, 224 South 3d St., Phila., Pa.

**The American Gas Engineer
and Superintendent's Handbook.**

BY WILLIAM MOONEY.

Consisting of Rules, Reference Tables, and Original Matter
Pertaining to the Manufacture, Manipulation, and
Distribution of Illuminating Gas.

350 Pages, Full Gilt Morocco. Price, by Mail, \$3.00.

A. M. CALLENDER & CO., 42 Pine St., N. Y.

GAS METERS.

GAS METERS.

GAS METERS.

ESTABLISHED 1859.

JOHN J. GRIFFIN & CO.,

Nos. 1513, 1515, 1517, & 1519 Race St., PHILADELPHIA.
 No. 52 Dey Street, NEW YORK. No. 75 North Clinton Street, CHICAGO.

Manufacturers of Meters for Measuring Gas

IN ANY VOLUME.

EXPERIMENTAL APPARATUS FOR QUANTITATIVE AND QUALITATIVE ANALYSIS.

Provers, Gauges, Registers, Etc.

Careful and Prompt Attention paid to the Repairing of all kinds of Meters and Apparatus.

Estimates Cheerfully Furnished.

Dry Gas Meters.

With 40 years' experience and the best facilities for manufacturing, is enabled to furnish reliable work and answer orders promptly.

NATHANIEL TUFTS,

No. 153 Franklin Street, Boston, Mass.,

MANUFACTURER OF

DRY GAS METERS.

Station Meters of any Capacity.

Test and Experimental Meters, Pressure Registers, Pressure Gauges, Pressure and Vacuum Gauges.

METER PROVERS, PHOTOMETERS, STREET LANTERNS, ETC., ETC.

Patent Cluster Lanterns for Street Illumination.

HAROLD J. BELL.

BELL & JONES,

S. LEWIS JONES.

No. 12 North Ninth Street, Philadelphia, Pa. Works at Royersford, Pa.

MANUFACTURERS OF

GAS METERS, STATION AND EXPERIMENTAL METERS,

Meter Provers, Pressure Gauges, and All Other Gas Appliances in Our Line.

WE REPAIR ALL KINDS AND MAKES OF METERS, AND THE WORK GUARANTEED.

High Pressure Meters for Natural Gas, in Iron Cases, guaranteed to stand 300 lbs. Pressure.
 Gas Cooking and Heating Stoves, Hot Plates, Cake Griddles, Waffle Bakers, Boiling Stoves, Laundry and Tailors' Iron Heaters. Hotel and Cafe Ranges a Specialty.

Correspondence Solicited.

Estimates Furnished.

SCIENTIFIC BOOKS.

All books forwarded by express, upon receipt of price; if sent by mail, postage must be added to price given. We take pains in forwarding any other Works desired. Remittances by check, draft, or P.O. money order.

KING'S TREATISE ON THE MANUFACTURE OF COAL GAS. Three vols; \$10 per vol.
 GAS MANUFACTURE, by WILLIAM RICHARDS. 4to., with numerous Engravings and Plates, in Cloth binding. \$12.
 TECHNICAL GAS ANALYSIS. \$3.00.
 GAS CONSUMER'S GUIDE. \$1.
 A GUIDE TO GAS LIGHTING. 40 cents.
 GAS MEASUREMENT AND GAS METER TESTING, by F. W. HARTLEY. \$1.60.
 GAS CONSUMER'S HANDBOOK, by WILLIAM RICHARDS, C.E.; 18mo., Sewed. 20 cents.
 A PRACTICAL TREATISE ON GAS AND VENTILATION, with Special Relation to Illuminating, Heating, and Cooking by Gas, by E. E. PERKINS. \$1.25.
 PRACTICAL TREATISE ON HEAT, by THOMAS BOX. Second edition. \$5.

COAL; ITS HISTORY AND USE, by PROF. THORPE. \$3.50.
 THE GAS WORKS OF LONDON, by COLBURN. 60 cents.
 THE GAS FITTER'S GUIDE, Showing the Principles and Practice of Lighting with Coal Gas, by JOHN ELDRIDGE. 40 cents.
 MUNICIPAL LIGHTING, by F. H. WHIPPLE. \$1.
 GAS WORKS, AND MANUFACTURING COAL GAS, HUGHES. \$2.20.
 THE MANAGEMENT OF SMALL GAS WORKS, by C. J. R. HUMPHREYS. \$1.
 MANUAL FOR GAS ENGINEERING STUDENTS, by D. LEE. 40 cents.
 HOW TO MANAGE GAS, by F. WILKINS. Paper. 20 cents.
 THE DOMESTIC USES OF COAL GAS, AS APPLIED TO LIGHTING, by W. SUGG. \$1.40.
 DISTILLATION OF COAL TAR AND AMMONIACAL LIQUOR, by GEO. LUNGE. New Edition. \$12.50.
 ILLUMINATING AND HEATING GAS, by W. BURNS. \$1.50.

A TREATISE ON THE COMPARATIVE COMMERCIAL VALUES OF GAS COALS AND CANNELS, by D. A. GRAHAM. 8vo., Cloth. \$3.
 GAS COMPANIES DIRECTORY. \$3.
 GAS VERSUS ELECTRIC LIGHT. 50 cents.
 THE AMERICAN GAS ENGINEER AND SUPERINTENDENT'S HANDBOOK, by WM. MOONEY. \$3.
 DIGEST OF GAS LAW. \$5.
 GAS ENGINE INDICATOR DIAGRAM, by W. E. AYRTON. Paper. 20 cents.
 TESTING PIPES AND PIPE JOINTS, by M. M. PATERSON. 80 cents.
 DESIGNING WROUGHT AND CAST IRON WORK, by H. ADAMS. Paper. Three parts, 60 cents each.
 NOTES IN MECHANICAL ENGINEERING, by H. ADAMS. \$1.
 STRAINS IN IRONWORK, by H. ADAMS. With plates. \$1.75.
 GAS WORKS—THEIR ARRANGEMENT, CONSTRUCTION, PLANT, AND MACHINERY. \$8.

A. M. CALLENDER & CO., 42 Pine Street, New York.

GAS METERS.

GAS METERS.

GAS METERS.

GEO. J. MCGOURKEY, Prest.

WM. H. MCFADDEN, Vice-Prest. (Phila.)

WM. N. MILSTED, Gen. Supt. and Treas. (New York).

WM. H. DOWN, Sec.

THE AMERICAN METER CO.

WET AND DRY GAS METERS.

PRESSURE REGISTERS.

METER PROVERS.

STATION METERS.

PRESSURE & VACUUM REGISTERS.

PORTABLE TEST METERS.

EXHAUSTER GOVERNORS.

PRESSURE & VACUUM GAUGES.

EXPERIMENTAL METERS.

DRY CENTER VALVES.

CRESSON GAS REGULATORS.

AMMONIA TEST METERS.

GOVERNORS FOR GAS WORKS.

MARSLAND WATER METERS.

BAR & JET PHOTOMETERS.

Manufactories:

512 West 22d St., N. Y.
Arch & 22d Sts., Phila.

GAS STOVES.

SUGG'S "STANDARD" ARGAND BURNERS,
SUGG'S ILLUMINATING POWER METER,
Wet Meters, with Lizar's "Invariable Measuring" Drum.

Agencies:

177 Elm Street, Cincinnati.
244 & 246 N. Wells Street, Chicago.
810 North Second Street, St. Louis.
222 Sutter Street, San Francisco.

HELME & McILHENNY,

(Established 1848.)

GAS METER MANUFACTURERS,

Nos. 1339 to 1349 Cherry Street, Philadelphia, Pa.,

WET AND DRY GAS METERS, STATION METERS, EXPERIMENTAL METERS, METER PROVERS,

Center Seals, Pressure Registers, Governors, Indicators, Photometers, and all other kinds of Apparatus for use in Gas Works.

FOULIS' PATENT STATION AND DISTRICT GOVERNORS.

REPAIRING DEPARTMENT.—We employ a special force of skilled workmen repairing meters of all makers.

WM WALLACE GOODWIN, Prest. and Treas.

WM. H. MERRICK, Vice-Prest.

S. L. JONES, Sec.

S. V. MERRICK, Supt.

THE GOODWIN GAS STOVE AND METER CO.,

Successors to W. W. GOODWIN & CO.

1012, 1014 and 1016 Filbert St., Phila., Pa.

142 Chambers St., New York City.

76 Dearborn, St., Chicago, Ills.

WALDO BROTHERS, Agents, 88 Water Streets, Boston, Mass.

MANUFACTURERS OF

DRY AND WET GAS METERS,

Station Meters (square, cylindrical, or in staves), Glazed Meters, King's and Sugg's Experimental Meters, Lamp Post Meters, etc., etc. Meter Provers (sizes 2, 5, and 10 feet), Pressure Gauges of all kinds, Pressure Registers, Pressure and Vacuum Registers, Pressure Indicators (sizes 4, 6, and 9 inch), King's Pressure and Vacuum Gauges, Dry and Wet Center Seals, Dry and Wet Governors, Exhauster Governors, Photometers of all descriptions. Letheby's Sulphur and Ammonia Test Apparatus complete. Also, Testing and Chemical Apparatus of all kinds, and of the most perfect description, for all purposes relating to Gas.

Manufacturers of the "SUN DIAL" GAS STOVES, for Cooking and Heating.

Goodwin's Improved Lowe's Jet Photometer.

Agents for Bray's Patent Gas Burners and Lanterns.

Special attention to Repairs of Meters and all Apparatus connected with the business. All work guaranteed first-class in every particular. Orders filled promptly.

G. B. EDWARDS, Manager, New York.

S. S. STRATTON, Manager, Chicago.

D. McDONALD & CO.,

GAS METER MANUFACTURERS.

(Established 1854.)

51 Lancaster St., Albany, N. Y.

34 & 36 West Monroe St., Chicago, Ill.

STATION METERS, EXPERIMENTAL METERS, METER PROVERS, PRESSURE & VACUUM REGISTERS, PRESSURE GAUGES, ETC

Also STAR GAS STOVES, RANGES, and HEATING STOVES.

We use only the very best materials, and employ the most skilled labor, and by our long experience (32 years) and personal supervision of every detail, we feel justified in assuring the public that our goods will give perfect satisfaction. Every Meter emanating from our establishment will bear the State Inspector's badge, and will be fully warranted by us. Our Annual and Calendar will be sent to Gas Companies upon application.

GAS INTO POWER,

BY THE

OTTO GAS ENGINE.

GAS POWER.—A Source of Revenue to Gas Companies ready to engage in Electric Lighting, building of Water Works, Electric Street Railways, etc.

Coal for producing Gas is less in amount than that for producing Steam, both being measured on an equal amount of work performed. And, further, with Gas,

50 to 90 per Cent. of Value of Coal is Returned

by sale of Coke and Tar, according to the market value of these products.

Labor for handling fuel is reduced, by its becoming centralized and confined to the gas house, and frequently has not increased after the addition of a power station.

With Gas Power, cost of fuel is strictly limited to the time of use.

MANY VALUABLE
AND RECENT
IMPROVEMENTS.

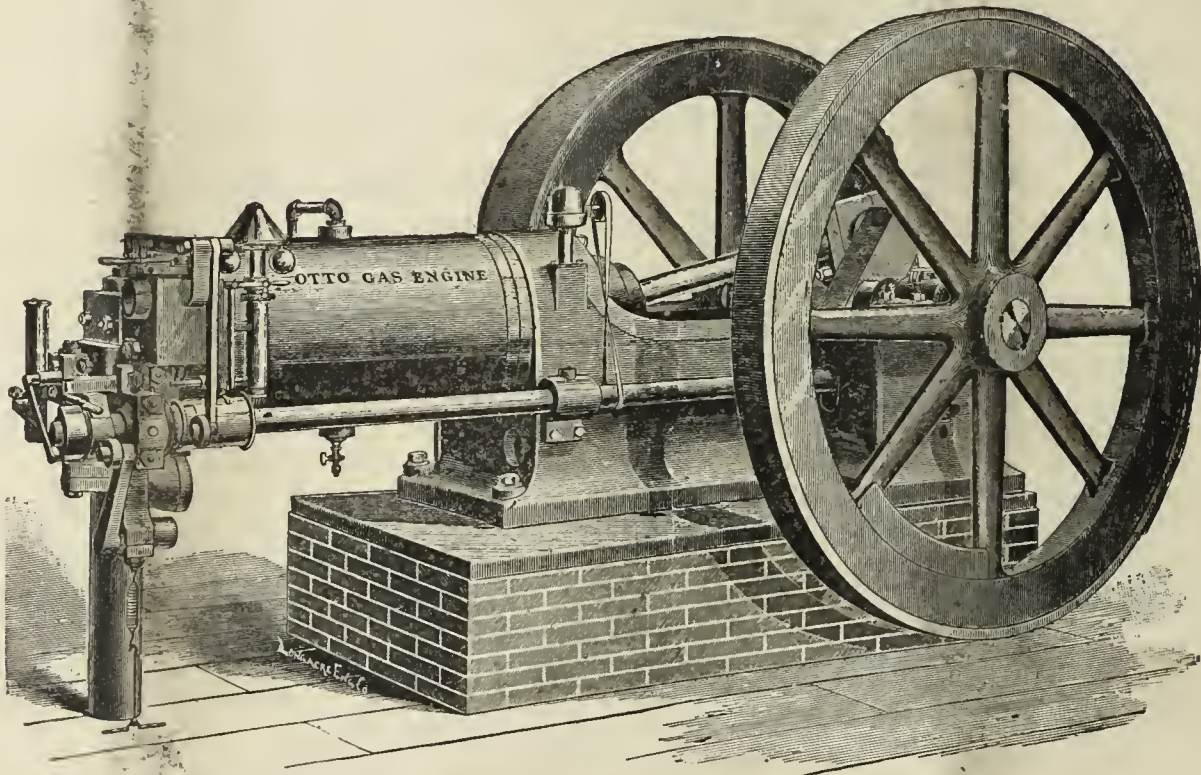

SIZES,
1-3 to 100
HORSE POWER.

Wherever Gas Companies tried Gas Power with Steam Power together in one Station, the use of Steam was subsequently abandoned or restricted, and Gas Power made to take its place.

Where Gas Companies adopt Gas Power for Electric Plants, Water Works, Sewerage, etc., they not only choose the most economical power for their use, but secure to themselves the numerous advantages of increased production, without increase of expense, and benefit thereby their entire manufacture. They induce consumers, by their example, to abandon Steam for Gas Power, and, by establishing special rates, make

Gas Power the Leading Power of To-Day,
AND SOLVE AT ONCE THE QUESTION OF FUEL GAS.

“Otto Gas Engine Works,”

SCHLEICHER, SCHUMM & CO.,

151 Monroe St. (Kent Building), Chicago.

222 and Walnut Sts., Phila.

NEW YORK AGENCY, 18 VESEY STREET.

THE AMERICAN

GAS LIGHT JOURNAL

REDMAN & KENNY, N.Y.

PUBLISHING OFFICE NO. 42 PINE STREET

DEVOTED TO THE INTERESTS OF ILLUMINATION, VENTILATION, WATER SUPPLY AND DISTRIBUTION, & GENERAL SCIENCE.

VOLUME LII.—No. 9. }
Whole No. 769. }

NEW YORK, MONDAY, MARCH 3, 1890.

{ \$3 PER ANNUM,
IN ADVANCE. }

A. M. CALLENDER & CO., Proprietors. C. E. SANDERSON, Manager.
JOS. R. THOMAS, C.E., Editor. T. J. CUNNINGHAM, Asst. Editor.

ENTERED AT THE POST OFFICE AT NEW YORK, N. Y.
AS SECOND CLASS MATTER.

Published on each Monday of the year, at No. 42 Pine Street, N. Y.

Terms of Subscription, Including Postage.—For the United States and Canada, \$3 per annum. European countries, \$4.50 (19 shillings—22½ francs). All payments to be made in advance. Single copies, 10 cents.

Remittances should be made either by post-office order, registered letter, or bank draft on New York, payable to the order of A. M. Callender & Co.

Collections are invariably made directly from this office, for subscriptions, advertisements, etc. We have agents to solicit the same, but they are not authorized to receipt for money.

Correspondence.—Wishing to make this JOURNAL a gazette of intelligent discussion to those of our readers who may wish to gain or give information on the subjects to which its columns are devoted, correspondence is solicited for publication from all who make the study of those subjects a pleasure or a profession.

CONTENTS.

An Asterisk (*) denotes an illustrated article.

OFFICIAL NOTICES—

Southwestern Gas Association	277
Ohio Gas Light Association.....	277

EDITORIALS—

Briefly Told.....	278
The Toledo Meeting—In Bad Faith.	

Twentieth Annual Meeting, New England Association of Gas Engineers—Official Report, Revised by the Secretary—Continued from page 248.....	278
---	-----

First Day, Morning Session: President's Address—Committee on President's Address—Treasurer's Report—Amendment to Constitution—Committee on Nomination of Officers—Memorial Committee—Reading the Invitations—Reading the Papers—Municipal Control of Gas and Electric Lighting, by Dr. R. Amory, Brookline, Mass.—Discussion.

Special English Correspondence.....	286
-------------------------------------	-----

The Gas Stokers' Strike in South London—The Gas Light and Coke Company—Gas Testing in London—Gadd & Mason's Gasholder Construction.

Public Lighting Malden, Mass.....	287
-----------------------------------	-----

ITEMS OF INTEREST FROM VARIOUS LOCALITIES.....	287
--	-----

Mayor Noonan's Veto—Improvements at the Laclede Works—Increasing the Capital Stock—Betterments at San Jose, Cal.—Corning (N.Y.) Company to Go into Electric Lighting—Sale of the Evansville (Ind.) Plant—Personal—Will it Interfere with the Huntington (L. I.) Gas Works?—The Explosion at Northampton, Mass.—Resolutions Aimed at the Louisville (Ky.) Company—Death of J. Aiphonse Pagaud—Death of Mr. H. H. Button—Suit for Damages—Death of Mr. Jacob Nichols—Public Lighting, Oshkosh, Wis.—New Gas Company—Annual Meeting, Petersburg, Va.—Annual Meeting, Augusta, Ga.—Betterments at Wheeling, W. Va.—Chapters from Syracuse, N.Y.—Hint from Dallas, Tex.—And Many Other Items.

The Market for Gas Securities.....	290
------------------------------------	-----

[OFFICIAL NOTICE.]

Southwestern Gas Association.

OFFICE OF SECRETARY, GALVESTON, TEXAS, Feb. 24, 1890.

The annual meeting of the Southwestern Gas Association will be held in Dallas, Texas, March 12 and 13, 1890. The arrangements for the meeting are now being perfected. Headquarters will be at the Windsor Hotel.

C. P. RUSSELL, Sec'y.

[OFFICIAL NOTICE.]

Ohio Gas Light Association.

OFFICE OF SECRETARY,
COLUMBUS, O., February 22, 1890.)

To Members of the Ohio Gas Light Association:

Gentlemen—As previously announced, the Sixth Annual Meeting of this Association will be held at Toledo, O., beginning at 10 A.M., March 19, 1890, and continuing two days. Boody House will be the headquarters of the meeting, the various sessions of which will be held in a very suitable room in the same hotel. Members and others desiring to attend are advised to write well in advance for rooms.

The following papers have been promised for the meeting:

1. "Theory and Practice in Gas Management," J. M. Bate, Supt. Gas and Coke Company, Canton, O.
2. "Municipal Control of Lighting," H. Wilkiemeyer, Supt. Gas Light and Coke Company, Portsmouth, O.
3. "Combination of Gas and Electric Lighting in a Small Town," George W. Bowers, Sec. Gas and Electric Light Company, Hillsboro, Ohio.
4. "Our New Coal Gas Works," G. A. Hyde, Engineer Gas Light and Coke Company, Cleveland, O.
5. "Advantages of a Combined Coal and Water Gas Plant," Geo. Light, Asst. Supt. Gas Light and Coke Company, Dayton, O.
6. "Another Year with Fuel Gas," Chas. H. Evans, Manager National Gas Company, Jackson, Mich.
7. "Ohio Street Lighting Statistics," W. C. Hedges, Secretary Gas Light Company, Mansfield, O.
8. "Graduated versus Uniform Rates," Chas. R. Faben, Jr., Supt. Gas Light and Coke Company, Toledo, O.

The following questions have been proposed for the "Question Box:"

1. At what point in the works is the best place for the exhauster?
2. In a lighting territory covered by illuminating gas and the incandescent electric light, which seems to be in the ascendancy?
3. Does a fine gas of 23 to 25-candle power help check the invasion of the incandescent electric light?
4. Should we not confine the work of our Association to the important interest it was established to promote, viz.: gas lighting and the manufacture of coal gas?
5. What system of electric lighting is best for adoption by gas companies?
6. Are cast iron pipes better and cheaper than wrought pipes for gas mains of 2 to 4 inches in diameter?
7. Does it pay to coat gas mains with coal tar?
8. What is the average life of a meter in constant use, with ordinary good care?
9. Is not illuminating gas of good candle power, sold at a reduced price for fuel, the true solution of the fuel gas problem?
10. Which is the correct method of tapping mains, on top or at the side?
11. Is the Welsbach burner with natural gas a success, and what proportion of the lighting does it do in towns having both natural and artificial gas?

Other interesting questions have been proposed, which will be presented at the meeting, and members are requested to come prepared to participate in the discussion of the above papers and questions.

Provision has been made for an exhibit, in connection with the meeting, of all kinds of gas appliances and apparatus, a large room on the ground floor, a few doors from the hotel, having been secured for this purpose. No charge for floor space will be made to exhibitors, and those desiring to avail themselves of this excellent opportunity of displaying their specialties will consign their goods and address their communications to Mr. Chas. R. Faben, Jr., Supt. Gas Light and Coke Company, Toledo, O., who has the matter in hand, and who will arrange the exhibit to the best advantage of all concerned.

In addition to this exhibit there will be other objects of much interest to our members and visitors, and the meeting promises to be in every way successful. It is hoped that every member will show his appreciation of what has been done, by being present; and gas companies not heretofore represented at our annual gatherings will be profited by sending a representative to this meeting.

A cordial invitation is constantly extended to all who may desire to become members of the Association, to do so, and the Secretary would be pleased to hear from any such persons.

IRVIN BUTTERWORTH, Sec'y.

BRIEFLY TOLD.

THE TOLEDO MEETING.—With the echoes of the New England meeting, and all its lessons of progress and union, still fresh in the senses of the fraternity, our thoughts and hopes are directed toward the annual gathering of the Ohio Association, soon to be held in Toledo, under the guidance of Mr. Lindsley, of Cleveland. The current number of the JOURNAL contains Secretary Butterworth's official outlining of what the members are to have placed before them. In the first place, the local committee have been eminently successful in their matter of a choice of a hotel—the Boody House—which is also to be availed of as a place for meeting. This assures goodly and regular attendance at the sessions, at least in so far as these things depend on any preparations in advance. Passing, but not lightly, from the Secretary's hint about the wisdom of writing well in advance for rooms, we are confronted with the paper list, which amply proves that the sixth annual meeting will not suffer from lack of presentation of topics at once timely and interesting. In connection with the list, we note that some of the papers ought to prove more than ordinarily attractive, since apart from the intrinsic merit of their matters, some of these cannot fail subsequently to be placed in direct comparison with those read on kindred subjects at the New England meeting. The "Question Box" initiation at the Ohio meetings will be most auspiciously inaugurated, since no less than 11 queries have already been committed to its custody. Some of them, too, are on the decidedly complex order, which, of course, will cause their unravelling to be all the more eagerly looked forward to. We would place especial stress upon the Secretary's invitation to the manufacturers of all sorts of gas appliances to send on lines of their goods for display at the proposed exhibition of such, in connection with the convention. The only expense they will be at will be in the forwarding of their exhibits, and the most conservative of the manufacturers must of necessity concede that the advertisement gained will more than repay them for any expenditure so incurred. Even with the hurriedly arranged exhibition at Mansfield, last year, a very creditable display was made, and the exhibitors have no reason to regret that they took part in the affair. A master hand—that of Mr. Chas. R. Faben, Jr.—is in charge of the Toledo exhibition, and it is due to him and the Association that their efforts be encouraged by a good display. That is the recompense which will best humor them. The outlook for a successful gathering is most promising.

IN BAD FAITH.—We are informed that the City Attorney, of Thomasville, Ga., at the request of the City Council, has delivered an opinion respecting the right of that community to grant exclusive privileges to a corporation for a term of years. He declares that a contract between any Georgia city and any corporate company under which exclusive privileges are granted the latter is not binding upon the city unless the city's charter specifically confers such powers. The construction of the law arose from a contest between the city of Thomasville and the proprietors of the Gas Company as to whether the exclusive portion of the Company's charter—to run for 25 years—was valid. When certain capitalists invested their money in a gas works for Thomasville the authorities promised them protection. Now that the money is invested, Thomasville turns them adrift. It is only the same old story—bad faith.

OFFICIAL REPORT.—REVISED BY THE SECRETARY.—CONTINUED FROM PAGE 248.]

TWENTIETH ANNUAL MEETING, NEW ENGLAND ASSOCIATION OF GAS ENGINEERS.

HELD AT YOUNG'S HOTEL, BOSTON, MASS., FEB. 19 and 20, 1890.

FIRST DAY—FEB. 19—MORNING SESSION.

PRESIDENT'S ADDRESS.

President Taber then delivered the following address:

Gentlemen of the New England Association of Gas Engineers:—We meet again to-day as fellow soldiers may, conscious of a forgetfulness born of the very intensity of our absorption in our profession—almost as if the new rays of the incoming morning had greeted us un-awares, so busy have we been in the attempt to meet the increased demand, both mental and physical, developed in the past year.

As a manifest of that activity I have counted the number of papers offered, their wide scope and practical bearing; in fact, the number here present is in itself an earnest that we have need of one another's goodwill and co-operation in the endeavor to do faithfully our "little daily work." For myself I have no word of apology. I did not deserve the honor at your hands; I shall do my best not to disgrace it.

But even now as we gather I listen in vain for the answer in the roll call to the name of one who always answered, and hear only in my memory the funereal tolling of that bell in the quiet graveyard, constantly reiterating in hushed tone the sense of loss we all felt in the death of our friend and associate, Oliver E. Cushing.

"Oh, thicker, deeper, darker growing,

The solemn vista of the tomb

Shall know henceforth another shadow

And give another cypress room—"

Who of us is ever prepared for the death of his friend? I could but think, as on that January day we stood beside the grave decked with evergreen under the drooping sky, the swiftly rushing waters mocked the preacher's words—for were they not rapidly passing away, too—dust to dust—pain and sorrow and loss.

We are not met to-day for sentiment, yet who does not feel that sense of loneliness which closed in as we drove through the ivy-covered gateway and left our friend forever. I want to bear witness to the warm-heartedness, the cordial sympathy, the honest manliness of our associate. You will, I have no doubt, take later action in regard to his memory; but I wish right here to say that I took the liberty in your name to wire at the time my sense of the loss this Association feels as Engineers and men in his sudden death.

In common with the members of the National Association, we shall join in a similar tribute of respect to Mr. Forstall, of Chicago; but our loss in Mr. Cushing is peculiarly ours. No one among us will be more missed than he.

But, gentlemen, as I look over the interests of the gas companies to-day, I wish to premise my observations on a legal decision of Judge Story, who, in a certain case, defined the office and functions of a gas company as a public corporation, not in the sense of a municipal institution, but a quasi-public corporation, devised simply for the purpose of gain. Fortified, therefore, by such a weight of legal acumen, and removed from any stigma (since this is a judicial remark, not a forensic appeal), I presume we must all concur that as the official servants of these gain-seeking corporations we also have this aim in view, in gathering here year after year, viz., such comparison of ideas, plans and investigations as shall bring increased revenue to the corporations with which we are connected, increased light at lower rates to the public, and shall subserve their and our highest business interests. And I dwell somewhat strongly on this basic theory, so-to-speak, of our duties as an Association, since I am afraid that the ancient definition of our special duty as gas engineers may require a creed-changing committee to make it conform to the modified status of the business of furnishing such substitute for daylight as shall be pronounced by our customers every way satisfactory in convenience, everyday adaptability, and, above all, cheap.

I can fancy a club of gas engineers formed for the scientific part of the illuminating gas problem—the chemical section, so-to-speak, of our business. Such an one might spend the hour turning and overturning the theory of the illuminants, measuring their strength and the differentials of various gaseous compounds, perhaps even building up by synthetic processes a gas, innocuous, more luminous, with or without heating qualities, and capable of easy distribution—I sincerely hope also far less wasteful in destructive distillation. To such a body skilled mechanical

engineers might be added, who would construct the formula required for the best erections of plants and laying of mains, the best methods of furnace erection in regenerative benches, or plans of retort house or holder frames. Such a gathering might strictly be called an Association of Gas Engineers, the single aim being adhered to with more or less directness of purpose, of consulting together as to method of manufacture—the applied chemistry and engineering of our special hobby.

On the contrary, to-day I think the twentieth meeting of our Association convenes feeling more or less indistinctly the pressure of an impulse which warns us that the day must not be spent in scientific problems, or theoretical speculations on the manufacture of illuminating gas, important as we have always considered it. I do not allude, perhaps, to any anxiety arising from any existing competition of coal gas with electricity or water gas, as that indefinable sense of a public demand for something which necessitates greater care and thought as regards our relation to that demand. In fact, we to-day lay ourselves open to the criticism that we are no scientists at all, through the necessity of meeting the requirements of such a demand as I have mentioned, which, since the advent of electricity, has grown acquainted with its wants and recognizes any dilatoriness in the good will or ability of a gas company to meet it.

I am glad of the position taken by the Gas Commission, which has resulted in doing away with much of the mystery attending the cost of gas from the public mind, which exaggerated the unknown quantities, both depressing the cost and swelling the profit. This removed, the public has learned to expect better results; and I therefore feel an absolute indifference to any party criticism, whether your discussions shall relate to any topic relative to artificial light and heat, since for the purpose of gain we are gathered not as illuminating gas engineers, not as fuel gas engineers, not as electric engineers—because each of us is or should be all these, and because, by reason of this public demand, we are not so much interested specially in the method and economy of their manufacture as directly in the method and economy of their sale. Perhaps, also, it might be broadly stated that both parties—the manufacturer and the consumer—have found it their interest to investigate the need and requirements of each special light installation, and thus it comes to pass that of the 126 gas companies doing business in New England probably 25 make and sell water gas and 36 electricity, while nearly all are engaged in the sale and rental of gas stoves and, in a less degree, fittings and chandeliers.

To me it seems as if some recognition should be taken of this change of direction (which, after all, may be only temporary), that we may have some idea of what is involved. Is it necessary and profitable, or necessary and unprofitable? Could there not be a medium path pursued without this equipment of the stove manufacturer and the fixture manufacturer, and, more broadly still, the arc and incandescent light? Whence arises this necessity? I answer, What was the necessity for regenerative burners, Lungren and Wenham, which were only partial efforts to perfect local illumination? The incandescent burner, water gas (itself a gas of 20 and odd candles), arc lamps, incandescent electric lamps—what are these but the answer to a call for something, more or less indistinct in the call, and more or less indistinct in application to the needs of a public which required something for usefulness or luxury which it did not possess?

"Blind mouths," we call them. Aye, but not to remain so; and because municipal opposition answers every attempt at anything over competitive prices, the franchise so valuable to any illuminating company of the good will of the community must be gained by reasonable rates and efficient service. Under this pressure many of the petty items of management—meter rents, cost of service and connection, interest on mains, small repairs, burners and tips—these minor sources of aggravations, must be more or less done away with. Skilled workmen must be employed to advise and assist in installation of stoves and gas fixtures and systems of piping. It is noticeable that in France the Paris Gas Company is even desirous of illustrating the advantages of gas as a source of ventilation, a point which I hope our architects also will take up. And like the shopkeeper we must subdivide our wares, because the public will have it so, and vend and sell as best we may—regenerative burners from our illuminating gas department, heating stoves and ranges from our fuel gas department, and electroliers and lamps from our electric department; and, therefore, many of us have come here to-day with this conviction, perhaps better felt than defined, that, to maintain a footing in our communities, care must be taken to make what the people want, as they want it, and learn how to skilfully sell it.

I have added advisedly the words "electric department" to the requirements of a gas company, although I am well aware all do not so consider it. All are agreed on the gas and stove departments, but the

competition of arc and incandescent lamps, irrespective of the corporate ownership behind them, is developing their use in places hitherto supposed impregnable. I shall perhaps be able to allude to this later; it is enough just now for my purpose to emphasize the business habits of the purveyors of electricity, their methods, often very faulty, but always telling in the matter of contracts and choice of customers. Some of their habits, which remind me of those old days when we heard the word pirate uttered savagely enough in these rooms, are not to be considered, perhaps, models; but surely among the new duties which 1889 gave to 1890, I place most prominently the necessity of care and skill in meeting the particular need of each of our consumers.

Connected with this subject, and necessitated by the same clamor of popular pressure, I would call your attention to the necessity of the Association as a body maintaining greater unity if possible in its attitude toward competition and general municipal legislation. There is nothing which has given the representatives of gas companies more respect and power than such an Association of intelligent men who could without any jealousy of interest freely compare notes and expressions and maintain a solid front against opposition. I recognize also the delicacy of any attitude which might be misunderstood to mean any combination against the actions of a legislative body from whom we have derived our charters; but I think this Association has a duty to itself in watching the course of private legislation and furnishing reliable information about matters connected with the gas interests.

The Massachusetts Legislature has bills before it now to repeal the 10 per cent. carbonic oxide law and the establishment of the office of gas commissioners, bills regarding the municipal purchase of works, gas and electric, the overhead wire system—a perfect Pandora's box filled for the nonce with panaceas and blessings. I know I voice the mind of this Association when I say that in the matter of the gas commissioners the repeal of the bill creating their office would be an injury to the best interests alike of the consumers and the gas companies. And I think some expression of this kind is due them from us; for if we have not wholly sympathized with them in all their decisions, no one certainly has ever failed to recognize the justice, legal fairness and courtesy with which these decisions were accompanied; and I would recommend that a suitable committee be appointed by this body, to have the care of this subject of municipal legislation in the different States represented here, and render such aid as may be required, drawing upon our Treasurer, not to exceed a given limit, for the necessary expense.

And now, as I survey the actual work done in 1889, what is the result of the review? The forthcoming report of the gas commissioners will tell of a prosperous year, of good dividends and fair prices. Mr. Hinman reports fair averages of candle power. No one, so far as I know, has reached the dollar limit; no one makes fuel gas; no new improvements of any importance in manufacture have been introduced, except in the substitution of Lima oil for cannel, and home-made iron sponge for lime. As I have before said, the attention of the gas engineer has not been called this way. I had hoped some results might have been reached from the system of inclined retorts, and yet more from the combined firings of Mr. Clark, which I must confess interested me greatly as a move in the right direction. When it is considered that 28 per cent. of the cost of the gas in the holder in America is represented by less than 10 per cent. abroad, it certainly is necessary not to cut down the daily price of labor, but to increase its efficiency by competent apparatus.

Of course, the two great movements of the year have been in the departments of water gas and electricity. Experience has finally solved the question of fuel gas to a question of appliances, and has confined it to my mind somewhat strangely to the development of gas ranges, the number of which has argued barometrically as it were to the activity or heaviness of the atmosphere of the gas company's office. I much regret that the exhibition which it was hoped might be made of heaters and ranges, and which was entered into so heartily by the leading manufacturers, had to be given up for this year at least. It would, I think, have been of interest to watch the development of the heater; for instance, from the plain reflecting stove through what might be called the regenerative plan of the Fuel Gas and Engineering Company to the steam heaters of the Backus type, and the furnace of Mr. Hawley. Here again the idea of locality and appropriateness of use suggests opportunity for each type, and I think the public demand a proper one for a good fuel at a reasonable rate. We need not be frightened at Mr. Young's figures. There will be plenty of time for the extension of our works before fuel gas is a success on such an extended scale as to require millions of capital; but I am heartily glad if the Michigan plan has earned its dividend, that it has dared to try the experiment at 30 cents per 1,000.

In water gas, however, much capital has been invested, mainly as

an auxiliary to coal gas plants, to obtain higher candle power and for prudential reasons. Many things have drawn attention to this subject, such as the visit of eminent gas engineers from England, the great strikes in the works at London, Birmingham and elsewhere, the cheapness of Lima crude oil, and the necessity of increased holder capacity. We have two papers on this subject, and I forbear to take your time.

I have already alluded to my own attitude regarding the electric department. My experience has been such that I could draw no other conclusion. Let me state the facts. For the two years 1886-87, the Gas Company in New Bedford was in opposition to two electric companies, one arc, the other incandescent, and barely held its own. Gas stoves, Lungren lamps a perfect sales department of fittings and fixtures, were no obstacles, and lower prices only resulted in decreased revenue. By the purchase of one plant and the development of a Westinghouse apparatus, the Company in 22 months added 4,500 incandescent lights and 400 arc lights, equal perhaps to 100 per cent. of the revenue and 150 per cent. of the total gas sale, if converted into gas figures. Could this have been done any other way? And yet more; for by the purchase of the Edison plant, now about consummated, a community of 37,000 has found a place for nearly 13,000 incandescents, 550 arcs, with gas sales of 42 millions. And I instance these figures not to boast how mushroom-like this demand has been as to call attention to the demand itself—its quality, its certainty, and the necessity of meeting it. Such questions as, "Could not this all have been done by gas," and "Would not the same capital have paid better?" resolve themselves into the habit of the public, their cultivation and needs. This abnormal demand for incandescent light argues two ways—either poor gas and poor methods of distributing it, poor general management, from the imputation of which we are relieved since we could sell electricity, or it argues a popular demand which will take nothing else. And, therefore, I think an electric department is justified, sometimes at least, and the whole argument resolves itself into some such ledger entry as this:

Dr. The most successful development of gas likely to be compromised by the attention paid to electricity; the excessive cost of capitalization, contract system, uncertain report and depreciation account; the novelty and possible short life of patents and consequent cheapness of inventions and capitalized plant; the unreliability of storage batteries; the danger to life and capital. While to its credit must be placed whatever intrinsic merits electricity may possess as a dividend winner, its own necessity, and the benefits of its control.

The year 1889 has diminished to some extent the debtor side, in furnishing some more reliable data on which to base the capitalization, the repair and depreciation, and danger accounts. Capitalization has averaged \$250 to each horse power, with the best of engines and dynamos; repairs and depreciation are placed within 5 per cent. of the investment; meters and contracts are not so much guess work as formerly, and the cost of electricity has proved not so widely variable in different conditions, or in fact so far different from the cost of gas as many have supposed. But I firmly believe that an opposition controlled by your self is a safe one, and there can be no incandescent lamp installed, except in a few isolated cases, which is not a menace or a substitute, actual or possible, of a gas jet; and the development of either high tension or continuous incandescent systems means the gradual extinction, not of the gas company, but of its immediate profits on any line of main in spite of the tendency and advantage of increased demand for light wherever the gas burner remains. In the race for future development I think both systems are equally matched. What regenerator benches will do, compound condensing engines will do, and though I do not expect we shall ever make gas by electricity at the rate of 17 cents per 1,000, this is as good an instance as any of the million possibilities which the gas engineer expects when he adds the electric department to his already overloaded brain. Mr. Fowler will call your attention more closely than I do to the necessities and economics of the subject. For myself, I have looked upon it somewhat as an insurance of the gas interest, until the *bona fide* legitimate business and popular demand convinced me of its intrinsic merits. I have been amused that the petroleum industry got hit by it as well as the gas. I shall certainly expect that neither prejudice nor unreasoning opposition will hinder a free discussion of the subject.

And now, gentlemen, I ask your attention to the papers which are to be presented by those whose names will give weight to their words. I would ask of each of you to take such advantage of the privileges of the Association that, recognizing some superiority in another's methods or work, you may feel free to ask and the right to expect an answer.

We shall all recognize, I have no doubt, the shadow under which we have met. We all know that each year to us also the horizon of our

purpose opens wider over the untracked seas. I repeat it is our duty to make ourselves acquainted with every revelation of light which can benefit mankind and by any system of municipal distribution. But as I look out over the blue waves so entrancing in the bright sunlight, I know also the possibilities of disaster and defeat and the necessity of conservative management and expense. On the one hand, lie the restriction of sales to new districts, new purposes; on the other the interminable vexations of patents, and the character of the business itself. In front of us our legitimate object this "gain," bringing with it the indorsement and good will of the community. As Matthew Arnold said of History, "The treasures indeed are ample, and we may reasonably fear whether we shall have strength and skill to own them."

COMMITTEE ON PRESIDENT'S ADDRESS.

Mr. Stiness—There is at least one subject in that address which should be referred to a committee for consideration; hence I move that the President's address be referred to a committee to be named by the Secretary, with instructions to report at this meeting. I ask that I may be omitted from the committee.

The motion prevailed, and the Secretary named as the committee Messrs. F. S. Richardson, C. D. Lamson, and H. B. Leach.

TREASURER'S REPORT.

The following report from the Treasurer was read, and, on motion of Mr. Stiness, it was received and placed on file:

Charles H. Nettleton, Treasurer, in account with the New England Association of Gas Engineers.

<i>Receipts.</i>	
1889. Balance.....	\$92 77
Received dues, 1888.....	\$9 00
" " 1889.....	99 00
" " 1890.....	273 00
	381 00
Admission fees, meeting 1889.....	115 00
Interest, Derby Savings Bank.....	30 37
Dinner tickets sold, meeting 1889.	180 00
	\$799 14

<i>Expenditures.</i>	
Expense of meeting, February, 1889—	
1889. J. R. Whipple	\$323 10
Z. M. Jenks.....	2 25
D. H. Bacon & Co.....	48 55
Dr. Lewis M. Norton.....	50 00
T. S. Bassett	22 00
J. R. Whipple	15 00
D. H. Bacon & Co.....	11 50
Derby Gas Co.....	15 51
	\$487 91
Chas. H. Nettleton, salary.....	200 00
Balance.....	111 23
	\$799 14
Permanent fund deposited in the Derby Savings Bank.....	\$600 00

AMENDMENT TO CONSTITUTION.

The President—You will remember that in the call for this meeting an amendment to the Constitution was referred to as having been accepted and approved by the Directors, and recommended by them to this meeting for adoption. The amendment is to Article IV., which now reads:

4. Any New England Gas Engineer may become an active member upon application to the Secretary, accompanied by the endorsement of two active members of the Association, and the membership fee of five dollars, the approval of the Board of Directors, and an election by three-quarters of the votes at any regular meeting of the Association, and by signing an agreement to pay such assessments as may be levied by the Board of Directors. Any Gas Engineer residing out of the New England States may be elected an honorary member by the same vote as is required for the regular election of members of the Association. Any person residing in New England, and connected with industries pertaining to the gas business, may become an associate member upon conditions prescribed for active members. None but active members shall vote or be eligible to office.

It is now proposed to omit the words "residing out of the New England States," in the seventh line. What action will the Association take upon the amendment?

On motion of Mr. Harbison, the amendment was adopted.

COMMITTEE ON NOMINATION OF OFFICERS.

The President—The next business in order is the appointment of a committee to nominate officers for the ensuing year. I wish to say right here that I deem Mr. Norton's action last year sufficiently valid to become the unwritten constitution of this body. He declined a re-election, and I think we had best adopt that plan in all our future work—unless we happen to get an extremely good President, and then we may re-elect him. As I look upon the matter, there are so many of you who are so much better than anybody else to become President of the Association that I think a change each year is the better plan. Therefore, I would like the nominating committee to consider that the President is not eligible to re-election, and I would like that to be the unwritten constitution of our body. Therefore, if it is your pleasure, the Secretary will take the names of a nominating committee, or the President will appoint one, if you so desire.

Mr. Stiness moved that the President appoint a nominating committee. The motion prevailed, and the President appointed as such committee; F. C. Sherman, A. K. Quinn and W. A. Learned.

MEMORIAL COMMITTEE.

Mr. Stiness—I move a committee be appointed to prepare a suitable minute to be spread upon our records with reference to the death of our brother, Oliver Edwards Cushing, and, as we have not the data at hand which would enable them to make a report at this meeting, that they be given authority to report in writing hereafter. I listened, Mr. President, with much interest to your remarks with regard to the death of Mr. Cushing; and, standing as we do to-day with the flowers hardly withered upon his grave, it is eminently fitting we should pause for one moment in the whirl of business to lay upon his fresh grave those flowers of memory, fragrant as they are to-day; and that we should recall him as one whom we have known for so many years as kind and gentle and a perfect man. I was pleased last night as I stood within these walls, and as many men came and gazed upon the counterfeit presentment of Oliver Edwards Cushing, to listen to the kindly feelings that they all expressed; and it brought back to my mind those words, perhaps familiar to you all, "It is pleasant to live in the memory of those we love, for that is not to die." This world is brighter and fairer because Oliver Edwards Cushing lived. I hope that the committee will be given authority, if not able to report to-day, to report in print, and that a copy of their report, suitably inscribed by our Secretary, be sent to the family.

The President—You have heard the remarks of Mr. Stiness, and I know that his motion has your approval, and that we do not need to take a vote upon the subject. I will appoint on that Committee Messrs. Stiness, Slater and Prichard.

READING THE INVITATIONS.

The Secretary read the following invitations to this meeting of the Association:

WALTHAM, MASS., Feb. 5, 1890.

MR. C. H. NETTLETON, Secretary:

Dear Sir—I wish to extend an invitation to the Association to visit the Loomis fuel gas plant in operation here at the works of the American Waltham Watch Company, at the time of the annual meeting this month. * * * * *

Yours very truly,
(Signed) WILLIAM TARBELL.

BOSTON, MASS., Feb. 17, 1890.

ROBERT B. TABER, ESQ., President N. E. A. of G. E.:

Dear Sir—The Boston Electric Club would be pleased to have the New England Association of Gas Engineers accept the privileges of the Club during the session of the Twentieth Annual Meeting of the Association, and extends a cordial invitation to members to visit the Club rooms, where they will be heartily welcomed. Very truly yours,

(Signed) HENRY B. CRAM, Prest.

Mr. W. A. Wood—I wish to say that the President of the Boston Gas Company, Mr. J. Edward Addicks, has extended a formal invitation to the Association to visit both the Bay State and the Commercial Point stations of the Company. It is proposed that at the close of the meeting on Thursday morning, which it is suggested shall not be later than 12 o'clock, the members shall take carriages and go from here to the Bay State works, where lunch will be provided, and that they afterwards visit the Commercial Point station. It will be necessary for some arrangements to be made, and we would, therefore, like to know how many will probably go. The idea is to get back in time to enable members who wish to do so to take the afternoon trains out of town.

The President—The three invitations are before us. What action will you take with respect to them?

Mr. Stiness—I move that the invitation of the Boston Electric Club be accepted. Being myself a member of that Club, I can assure the gentlemen present they will there receive a most cordial greeting from the electrical fraternity of New England. They have a very fine club room, and it is fitting that very close and fraternal feeling should exist between the two advocates of artificial illumination. I also move that the invitation from Waltham be accepted, with thanks. I suppose it would be almost impossible for all of us to visit Waltham, as the programme says that we are to visit the Bay State gas works. I move that that invitation be also accepted, and I feel that all who can visit the works will be well repaid for doing so.

Mr. Greenough—In regard to the visit to the Boston gas works, arrangements are practically as stated by Mr. Wood, that is, we should get away from here to-morrow by 12 o'clock, as we ought to get down to the Bay State works before 1 o'clock. We can get lunch there, visit the works, leave there at half past 2, get to the Commercial Point works at 3 o'clock, get away from there by 4 o'clock; and those who wish will be able to leave town by half past 4. I think any one can be sure of getting out of town by the 5 o'clock trains to-morrow afternoon.

The President—With regard to the invitation from the Electric Club, Mr. Stiness has moved that it be accepted, with thanks. [Adopted.]

The President—I confess the invitation to Waltham gave me great pleasure, but as we have already announced that we are going to visit the Boston works, it was thought best by the Directors that those who would like to go there and remain over on Friday, could visit Waltham. I am sure all who do go will be most heartily welcome. Mr. Stiness' motion is that the invitation be accepted with thanks; and while we cannot as an Association visit Waltham, that as many of our members as feel inclined to make the visit will do so, and that we acquaint Mr. Tarbell with the fact of our acceptance. [Adopted.]

The President—In the matter of the Boston Company's invitation, I certainly feel that we owe them many thanks for their kindness in the matter. It is desirable that as many as possible of the members shall accept the invitation, and that they be notified how many are likely to visit the works. I believe that all the business which we can attend to this morning is now completed, and we will listen to the reading of the papers. I will begin by asking Dr. Amory, of Brookline, Mass., to read his paper on the

MUNICIPAL CONTROL OF GAS AND ELECTRIC LIGHTING.

At the time I was invited by your Directors to write a paper on "The Municipal Control of Gas and Electric Lighting," we had just been through an experience in Boston which so illustrated the subject proposed, that my attention was very naturally attracted by certain phases of the question which have prompted the spirit of this address. I need not say that public discussion of the municipal control of gas manufacture is no new feature, and that many arguments for and against this control have been worn threadbare.

A few years ago I happened to be in the chemical laboratory, at Dresden, of a Professor of the Saxon University, when he was showing me the experimental results of some of his professional researches. It was in the twilight of evening, and being somewhat dark he lighted the gas jet. The illumination was so dim that he apologized for the poor light, and remarked that the city gas works were under the management of the municipal government, and, in consequence, the gas was of a very low candle power, besides being quite impure. I asked him if it was not cheap in price, and though I have forgotten what was the price he named, I remember being astonished at the high rate. I was then living at the best hotel in the city, and was obliged to dress and undress in my room after sundown by the light of an ordinary candle, because gas light was too costly for my landlord or his ordinary guests. I noticed also that the few apartments I visited in that city were lighted, except in the dining rooms and halls, by lamps or candles, in spite of the fact that Dresden is the capitol and court city of the kingdom of Saxony.

I had the same experience at Munich, and not at the time having any intention of managing a gas company, or its works, the affair passed out of my mind as one of the curiosities of German barbarity or poverty; nor did I, as I now regret, investigate further into the matter.

In our own country, the well known financial history of the Philadelphia gas works, managed by trustees appointed by the municipal government, is a curiosity of modern times.

This winter on the expiration of a three year's contract for lighting the streets of Boston by electric lights, the electric lighting companies, as my friend Mr. Neal, of the Charlestown Gas Company will bear me out, were confronted, at a conference with the Mayor of Boston, by the statement that if we would not agree to furnish light at 40 cents a night

for each street light, he would feel obliged to urge upon the city government the necessity of owning its own plant, so that the city might light its own streets.

Up to the present period, gas and electric lighting companies have been guarding only against the competition of their rivals, or the formation of new companies in their locality. They have even gone so far as to urge the parental arm of the State government to ensure to existing companies a monopoly of gas and electric light distribution. In our own State we are supposed to be protected by a Gas Commission, whose judicial and executive authority seeks to limit the sale of gas to companies already in existence, and the Commissioners apparently aim to settle differences between manufacturer and consumer upon an equitable basis of arbitration, rather than to discipline them by allowing the usual commercial custom of competition from companies additionally licensed to do business in the same territory.

That Board in its official reports, points to the fact that competition between rival companies invariably results in consolidation under larger capital investment, and so requires unnecessarily large dividends, which the communities should not be called upon to pay.

At the present time competition of private capital against private capital, previously invested, is not naturally a great cause for anxiety, because history shows that it will generally result in mutual compromise with fair dividends upon all moneys invested; if not by compromise, then by consolidation on a basis of larger capital, thus insuring the payment of omitted dividends which had been suspended during the sharp crisis of competition in previous years.

The *present* outcry is to save this payment of profit to private capital invested in gas undertakings by means of the municipal ownership and management of new plants built upon more modern processes of gas manufacture; and hence, supposed economy in cost of manufacture.

My purpose is to show the fallacy of this popular outcry, for I doubt if we appreciate how strong this demand is growing; and yet we know that the result of acquiescence and submission to this sensational effort will be as in private competition a duplication of invested capital to supply consumers within the same geographical limits. We all must recognize the fact that the same axiom prevails in our business as in other mercantile undertakings. The man or company that can make the largest sales of daily commodities can afford to do this at a smaller margin of profit than his competitor who makes small sales at larger profit. Long bills of sales and small profits will result in turning over invested capital more frequently every year; for instance, one cent made out of a dollar used ten times a year makes 10 per cent. profit during the year. We see an exemplification of this in the larger dry goods and grocery stores in our more populous towns. These do so much more business on capital invested that the small shops disappear very rapidly, and the large shops grow annually larger. Apply this principle to a city which lights its own streets from municipal gas works and consequently makes small sales at less profit. The same main which carries the gas of the private corporation to the shops and houses of its people could just as well supply gas to the street lights, and the private corporation can afford to do this at less cost on account of the larger amount of gas manufactured.

If a municipal government lights its own streets there is no inducement to its managers to increase the annual product of gas; and, therefore, having but a limited amount of gas to make, the expense for the long lines of mains will naturally increase the cost of manufacture. If the town of Brookline should lay independent gas mains for its own street lighting the cost would not be far from \$75,000, or an annual interest account at 8 per cent. of \$6,000; now, as this town used, in 1886, before electric lighting was introduced, 12 million feet of gas, this interest charge for mains would add 50 cents per 1,000 feet to the cost of gas, which otherwise could not be manufactured at so low a cost as compared with companies making a large product.

The North Attleboro Gas Company made for that year about 12 million feet of gas, distributed through less than 9 miles, and was obliged to charge \$2.63 per 1,000. The profit paid in dividend by that Company for that year was only \$800 over the interest which we have assumed as a proper charge for the town of Brookline to pay annually for its mains if used only for street lighting. It seems almost unnecessary to call your attention to the fact that if a town made its own gas every abutter would think he had the right to demand a street light in front of his own door.

During the year 1888 the Brookline Gas Company sold one-quarter of its gas for public street lights. The mileage of mains in Brookline gas territory was, for that year, 52; Boston, 129; Dorchester, 49; and Jamaica Plain, 26. Parallel pipes for these districts would double the capital required, and the cost of these mains in Brookline now amounts

to nearly one-third of its capital used for the manufacture of gas; and in Jamaica Plain to even a larger proportion.

It is quite true that in Boston the percentage which the sales of gas used for street lighting bear to its total sales is a comparatively small portion of its revenue; but there is the stronger reason for the non-investment in a duplication of its pipe mains. The interest on cost of these mains is a very light burden for the Boston Gas Company, as it bears an annual charge of 5 per cent. against 95 per cent. In the more sparsely settled suburbs of that city the receipts for public lighting help to reduce the cost of gas to the house owner.

In order to reduce the cost of distribution the management of a gas company should be zealous in promoting sales of gas in its local territory; therefore, sales should be made to municipal governments for street lighting at such a low price, within the bounds of reason, that a liberal distribution of street lamps should be provided by that government. This will help to pay an interest upon the money required to lay mains through the streets, and as no meters are needed to register the amount of gas consumed, the price of gas for public street service can be for a less sum per thousand than that sold to private consumers.

Allow me just here to protest against the public outcry that private corporations occupy the streets without paying for their use. Common law requires that a personal tax shall be levied upon gas mains laid in the streets of a town or city. The Brookline Gas Company has to pay on her mains, within the limits of Boston, an annual rate upon a valuation of \$35,000, amounting in the present year to a tax of nearly \$26 per mile of main. It is an indirect assessment upon the licensee to use these streets.

It is not necessary to discuss the question of a town entering upon a commercial plan of selling gas to private consumers. The objections to this are as obvious as those against keeping public grocery stores, candy or peanut shops, and meat markets. Nor would it be fair to tax the poor man who now does not use gas in order to supply the rich man who will use gas, no matter what it may cost.

Another serious objection to a town lighting its streets by taxation for the expenses of running a gas plant, naturally occurs in a liability to suits from private individuals meeting with supposed accidents, owing to a negligent illumination of its highways, as well as from other supposed liabilities. Towns do not fare well in suits for damages brought by private individuals; they suffer in costs for actions of tort more severely than private corporations.

We all know, as gas managers, how dangerous are the temptations to spend money in improving our gas plants and electric light installations by listening to the importunities of those who have patent processes for the manufacture of gas or improved electric apparatus, at a cost of merely nothing.

We are all familiar with the common saying that the sale of residual products produces such fabulous prices that the sum received will pay the whole cost of coal, and perhaps a portion of the labor in making gas. Municipalities can borrow large sums of money by special legislation "outside the debt limit," and, consequently, having good credit, can spend money *ad libitum*, especially if managed by men who receive salaries rather than a dividend of profits upon their investment. Directors are mighty wary of increasing the company's debt, which will injure the borrowing credit or cause the stockholders to vote them out of office.

We see this remark exemplified by the large debts in our New England cities and towns for the improvement of their streets, schools, parks, sewers, and water supplies; and this danger has required the intervention of legislative action to limit the borrowing capacity of towns, based upon their assessed valuations. If now we add to the temptations of spending money the authority and power for towns to install gas and electric plants, the taxpayer's burdens will be unduly increased.

I have merely run over some of the arguments against a town establishing its own gas plant. Why, it may be asked, should not a town install an electric plant with which to light its streets, provided the people prefer this method of illumination to that of gas? My answer can be derived from the details of the Gas Commissioners' report for the year 1888.

About \$5,000,000 of capital, bonds and liabilities, are invested in our State electric light companies. Their profits in 1888 from commercial and public lights together have realized about \$220,000, or less than 4 per cent.; but in most instances the liabilities from unpaid bills are carried into the profit and loss account, and amount to nearly \$108,000. If we deduct this from last year's income the profits are reduced to about \$112,000 on an investment of nearly \$5,000,000, or about 2 per cent., and if we exclude the two companies in Boston, this will leave the profit of that year's business for all the other companies in Massachusetts a sum

of \$27,000 on an investment of more than \$3,000,000, or less than 1 per cent. on investment.

Will any town with that showing care to go into the business of electric lighting for its own streets rather than hire the light from established companies? Is the business outlook promising? Are not the electric light companies undergoing the same discipline that our gas companies suffered from 30 years ago, when annual dividends to stockholders of gas companies were very small, and sometimes nothing.

There is one feature of the present day in reference to the subject before us that is only now beginning to form an important argument against municipal control of street lighting. I would have some hesitation in mentioning the argument before any but the audience now before me.

It is an open secret that to-day the profits from electric lighting are too small to induce any success in competition between companies exclusively engaged in this form of lighting; therefore, no municipality could reasonably expect to do a large amount of street electric lighting without combining with it gas lighting. You will see by the following extracts from the Directors' annual report to our Brookline Gas Light Company stockholders how, by a judicious combination of the two industries, a saving economy may be practiced:

"The sales of gas have increased so rapidly each year, that we shall soon outgrow our apparatus for gas manufacture and storage; in fact, this past season we have been obliged to use some of our reserve gas retort benches, on account of the large demand upon our resources. The full capacity of our retort house will yield us only 286,000 feet of gas a day, and during the long days at Christmastide we were obliged to manufacture a daily output of nearly 260,000 feet.

"We have only 8 benches. If we were lighting the same number of street lights as have been displaced by electric lights, we should be obliged to make 25,000 feet more per day for the long winter nights. If we should add to this daily requirement the gas needed for the private residences and public buildings now lighted by electricity, we should be obliged to increase our daily manufacture to 40,000 feet more than we are now making during the season when the nights are long. In other words, without our facilities of to-day for furnishing electric lights in addition to our gas sales, we should have been obliged to enlarge our retort house capacity by one-sixth. This would have required a new retort house to have been built more than 18 months ago, probably also an increase of our purifying capacity."

I ought here frankly to state that in gas companies which do also an electric lighting business, the general expenses, such as administration, rent, or interest on real estate, dividend of profits, general superintendence, taxes and other miscellaneous expenses are divided between the two investments concerned in gas and electric lighting.

Now what chance of competition can there be between a municipal gas and electric plant which furnishes only public lighting, and a private corporation which does or can furnish both public and private lighting by gas or electricity? Add to this the risks of suits for damages against infringements of patent devices used in electrical apparatus, and what city or town will care to assume this additional liability upon its taxpayers?

Municipal Electric Lighting.—What it cost Bangor to establish and maintain a plant.

Mayor Hart, on Jan. 20, received the following from the Mayor of Bangor:

"MAYOR'S OFFICE, BANGOR, ME., Jan. 18, 1890.

"Hon. Thomas N. Hart, Mayor of Boston—Dear Sir:—In reply to your request of Jan 8, will say: Our electric light plant, owned and operated by the city, is a success in every particular, and far exceeds the expectations of even the most sanguine. It consists of 165-light dynamo capacity, with 140 lights actually placed in the streets, all but seven being placed on mast arms; three circuits; total miles of wire, 36, run on poles; 2,000-candle power lamps; good quality of wire, well insulated. We have tried to have everything of good quality and work well done, and think we succeeded fairly well; and our total cost, including steam engine and boiler to be used in cases of emergency, has been about \$33,000. (Original estimate, \$27,000.)

"Our cost of operation, running all night every night, and making a liberal allowance for wear and tear, will not be far from \$6,500 per year, or 13 cents per night per light (or \$47.45 per light per year). This low cost is, of course, due to the fact that our plant is operated by water power owned by the city. We have steam auxiliary, however, and if operated by steam entirely our cost would not exceed 25 cents per night, and probably not be much over 20 cents. I believe any city situated as favorably for fuel as Boston can operate its own plant by steam for not exceeding 25 cents per night for 2,000-candle power arc lights, including

all expenses for wear and tear; and prices heretofore charged by private companies for this service are outrageous.

"I know the arguments that are put forth in their interest and the means taken to influence and frighten the average citizen, and particularly the members of the city government, for I have just been through it all. If you are inclined to investigate this subject to any great extent, I would suggest a pamphlet, *Municipal Lighting*, by Fred. H. Whipple, Mich., as likely to be of great help, and shall be pleased to give you such details of construction and operation of our plant as you may desire.

"Should have replied to your request earlier, but have been confined to the house by sickness for some time, and this is the first work I have done. Yours very respectfully, C. F. BRAGG, Mayor."

I must say that I am somewhat surprised at the contents of this letter, for the figures do not correspond with the experience we have had in Brookline, nor with those published by other companies in Massachusetts. Even suppose the city of Bangor has a water power which costs nothing, we cannot believe that its city government can buy good electric apparatus, or line wire, or poles or labor at any price less than some of the rest of us.

Let us analyze Mayor Bragg's figures by comparison with the usual commercial prices. I have seen some of the poles in Bangor, which are usually only 20 feet above ground; they would cost delivered about \$3 each. Thirty-six miles of poles would require:

Cost of 1,080 poles, at \$3, or.....	\$3,240
Cost of setting 1,080 poles, at \$2, or.....	2,160
Mast arms (133 in number) cost, at \$18.50 each.....	2,460
Double circuit of water proof wire, and labor of stringing, including cross arms, etc., per mile, at \$150....	10,800
Average cost of 150 electric lamp capacity, at \$75.....	11,250
Hoods and hanger boards, at \$6 each.....	798
Cost of station (including building, switch-boards, wiring, etc.).....	3,292*
	<hr/>
	\$33,000

Does this sum of \$33,000 really include the whole cost? I do not think so.

Estimate cost of maintenance for all-night service, 150 arc lamps, 36 miles circuit:

Three trimmers, at \$912 per year.....	\$2,736
Carbons, at \$3.50 per night.....	1,277
Dynamo man, at \$3 per night.....	1,095
Lines, repairing.....	912
(No charge for oil and waste, and no charge for water power.)	
Charge for depreciation of plant, including repairs, 20 per cent.....	6,600
Interest on capital, at 6 per cent.....	1,980
	<hr/>
	\$14,600

Cost of steam plant—

Steam plant, 200 horse power, at \$25 per H.P..	\$5,000
Steam pipe.....	500
Heaters and smoke flue.....	1,000
	<hr/>
	\$6,500

Maintenance of steam plant—

Depreciation, 15 per cent. on \$6,500.....	\$975
Interest, 6 per cent.....	390
Fuel.....	5,000
Oil and waste.....	600
Engineer and stoker.....	1,300
	<hr/>
	8,265
	<hr/>
	\$22,865

I have not counted in the miscellaneous expenses, which may be judged from our own experience to be of no inconsiderable account in the bill for maintenance; as for instance—

Globes.....	\$157 16
Repairs of lamps.....	125 76
Repairs of electric plant.....	440 00
Repairs of lines.....	1,625 00
Superintendence.....	500 00
Globes.....	102 12
Repairs of electric plant.....	2,593 37
Oil and waste.....	200 00
	<hr/>
Average expense for two years.....	\$5,743 41

* No estimate in detail could be made of this cost without inspection of the station, nor any allowance for auxiliary steam power referred to in letter.

The Mayor of Bangor may be a better manager than I am, but I do not see why our electric light companies in Massachusetts cannot produce a better result in their financial showing; for it does not seem to me that a plant of 150 arc lamps can be run at 13 cents a night without steam power, nor at 25 cents a night with the costs of the latter maintenance.

In Brookline we have about 36 miles of street arc lighting, and 129 lamps, and the expense costs us about 42½ cents. If we had 200 arc lights I estimate the actual cost for street lights about 33 cents per night. By the use of the Westinghouse alternating arc lamp system we are promised an annual saving in cost of maintenance for each lamp of \$20, or 5½ cents per night, or a net cost of 37 cents per lamp per night; or for a 200-lamp outfit a further reduction of 7 cents per night.

In conclusion, I wish from these preceding views to sympathize this deduction. There seems to be in the minds of the public an opinion that illuminating companies are pirates that prey upon the purses of the community, endeavoring to take every advantage of a supposed monopoly to make an exorbitant rate of profit. Hence Gas Commissions and City Councils are invoked to interpose the right of eminent domain to compel gas and electric lighting companies to sell their products at an unremunerative price. We see this cloud, no bigger than a man's hand now, in many cities and towns in New England. It is especially a dominant impulse in the mind of Mayor Bragg, as shown by his letter.

I again repeat that we as gas managers must down this monster of public opinion by concessions, and must try our luck at economy of management to increase our prospects of small earnings. We must do this by offers to light public streets and buildings at the lowest possible cost, or else suffer the consequences. The lamentable exhibition in Boston of a disposition to crowd down the throats of the civic authorities a reasonably large price for street lights and for public buildings has resulted in a cat and dog fight which would be ridiculous if it were not dangerous to our existence. The older gas companies have profited by a long experience in meeting this issue. I sincerely hope that our younger brethren in the electric light business will copy our policy, and thus put an end to the popular demand for municipal gas and electric lighting.

Dunkirk, N. Y., 55-arc light plant.—Investment price, \$13,338.71. Salaries of superintendent, engineers and firemen paid by Water Department.

One month's maintenance—

Superintendent's share of salary.....	\$75 00
Engineer's salary.....	90 00
Firemen.....	60 00
Interest on plant, 1 per cent.....	134 00
Rent of station and land per month.....	100 00
Depreciation of plant, 1 per cent....	134 00
Real cost of maintenance.....	\$633 00
Cost of maintenance as reported.....	225 28
	\$858 28

Average number of lights run during month, 55 arc lights. Total amount of coal consumed, 137,777 lbs., at \$1.65 per ton, \$113.55; number of carbons used, 3,412, at \$11 per 1,000, \$38.28.

6 gallons cylinder oil used, at 90 cents.....	\$5 40
5 gallons lubricating oil, at 35 cents.....	1 75
6 globes used, at \$1.....	6 00
10 carbon holders used, at 25 cents.....	2 50
6 brushes, at \$1.....	6 00
20 lbs. waste, at 9 cents.....	1 80
Amount paid for labor.....	50 00
Total cost for October.....	\$225 28
Total hours run.....	364½
“ cost of running 55 arc lights 364½ hours.....	\$225 28
“ “ “ “ “ 1 hour.....	62
“ “ “ “ 1 arc light 1 hour.....	01½

Discussion.

The President—The subject of Dr. Amory's paper is now before the meeting for consideration. We would like to have a very free discussion by the Association with regard to the matter. I presume the subject is of most interest to us who live in Massachusetts, and I will ask Mr. Greenough to give us his opinion upon the subject, as relating to Boston or his own personal ideas of the same.

Mr. Greenough—The question of municipallighting is a pretty wide one, and can hardly be touched on to the extent that I would like, in the few remarks that I shall have time to make here at the moment. I

think that Dr. Amory's paper is an admirable one, but I think he touches perhaps too lightly upon the probabilities of cities and towns going into the business for the purpose of supplying private lighting. I have no idea for a moment that the city of Boston, for example, will ever touch the gas business in Boston, unless they propose not only to buy the street lights, but also to supply the private lighting, and thus have a hack at the profits which gas companies are supposed to be making. I think that the Gas Commissioners have proved a most valuable auxiliary to the gas companies. The idea which the public has had for many years of gas companies has been erroneous. There was a time 30 years ago (so my father has told me), when he was sent for by the Mayor of Boston and asked as to the profits of the gas business, and the Mayor gravely told him that he understood that they were sufficient, not only to pay the expenses and the interest on the cost of the plant, but were also sufficient to pay the whole expenses of the city of Boston. The treasurer of the Gas Company had no difficulty in showing the Mayor that the entire gross receipts of the Gas Company would not pay a tenth part of the expenses of the city of Boston at that time; and the Mayor found out that he was in error. When cities do go into the gas business, they will do so for the purpose of making money, and not alone for the purpose of supplying a good light to the public. What Dr. Amory has hinted at in his suggestion as to the mismanagement of the works in Philadelphia, and of the works in Dresden, requires more than a hint to be adequately expressed. I do not wish to be understood as saying that all municipal gas works are mismanaged. I have in my mind one or two municipal gas works in different parts of Europe, where I think the management is admirable; and the gentlemen in charge are honorable men and men of marked ability. But those instances are so much the exception, that the rule is anything but favorable to municipal control. We are continually being confronted, by the agitators of a species of socialism, with statements as to the number of municipal gas works which are being run in different parts of England, Scotland and Germany; but there are very few of them which, on a more extended examination of their figures and accounts, would not tend to discredit these statements, and to cast discredit upon the advantages which are claimed by the socialists. Moreover, there is a very great feeling, on the part of advocates of cheap gas, that the ordinary consumers do not get the benefit of the reductions in the cost of gas manufacture; but that the gas works are run more particularly for the benefit of non-residents tax payers, or fully as much so as they are run for the benefit of the consumers of gas. And, although you have pointed out to you with pride, when you go to Manchester, England, the magnificent City Hall which has been erected out of the profits of the gas works, yet, there is another side to that question; and the gas consumer has been forced in Manchester to see the price of gas put up much higher than has been done for the gas of similar grade supplied by private corporations elsewhere. These facts are undeniable. Looking upon the present situation in this country and upon the situation abroad, where there has been such a demand for relaxation to the laborer in respect to the hours of working, and where we see one gas company after another compelled to yield to the demand for only eight hours of work, thus being placed almost under the dominion of the labor unions, we are led to inquire what we will come to in this country, where universal suffrage is in vogue, and where it is impossible to avoid the conclusion that if the city works were run generally by the city managements, there would be a very large increase in the number of men employed, and a corresponding decrease in the number of hours which they work; and the result might be that the cost of gas would be so increased as to put gas in a very disadvantageous position when brought in competition with electricity. At best, gas has to struggle for its existence. The time has gone by, as I remarked some years ago, when we could fix our own price and collect our money; and the time has come when we have got to sell our gas at a price which will enable us to compete successfully with electricity and petroleum. If the city were running gas works can it be considered possible that the gas would be manufactured as cheaply in any city of this country as it is now being done by private enterprise? There is another thing which I have not seen suggested, and yet which is undeniably true, and that is the putting of gas work, under municipal control would practically mean the stifling of inventions. Necessity is the mother of invention. Gas companies have to make gas cheaper, and they therefore call upon their engineers to devise the methods of doing it. The brains of the gas engineers of the world are continually at work trying to see how they can make gas cheaper. As I have said before, engineers in charge of municipal gas works in different parts of the world have done credit to themselves and their profession, and I think at once of Foulis, Hunt, Valon, Woodall and others; but the number of those from whom useful inventions

have come among the gas profession could be counted on the fingers of both hands. Practically all the steps forward that have been made in our business in the last ten years have been the results of private enterprise. Of course, in this country nearly all the gas business is in the control of private corporations; but the public corporations with which we are familiar are certainly the last to which we would turn for any assistance in that direction. In England and in Germany, especially in England and in Scotland, the best brains of our profession are in the employ, not of the municipal companies, but of the private corporations; because private corporations are willing, as a rule, to pay prices which city governments will not pay. I do not forget Mr. Foulis, of Glasgow, and Mr. Hunt, of Birmingham. I should consider that if the business of gas management went as a whole into the hands of municipal ownership it would be a decided step backward for the profession. The English gas companies which are under the control of private corporations, sell better and cheaper gas as a rule right through the country than the municipal corporations charge for the use of their commodity. I do not think it possible to do this subject justice in a five minutes' talk; and yet, Mr. President, I did not want to decline to respond to your call without saying a few of the things on the subject that come to my mind.

The President—As it is a matter which concerns Connecticut as well as Massachusetts, perhaps Mr. Harbison may have something to say upon the subject.

Mr. Harbison—I have not given this subject much thought. I was quite surprised at a remark made by Dr. Amory in his paper, to the effect that there was a very large public demand for municipal corporations owning lighting stations for the purpose of supplying public lighting. I had not heard that suggestion made in Connecticut. If he has reference to Massachusetts as the New England in which it is becoming general, that may be the fact—I am not so well posted as to Massachusetts; but I do not think that it applies to that large and prominent part of New England which is comprised within the border lines of the State of Connecticut. For myself, I have no faith in the municipal management of lighting stations. Municipalities may be very competent to take care of the street department, and can perhaps manage the water department, but I am not of the opinion that municipal corporations are eminently qualified for giving their fellow citizens light of almost any kind.

Dr. Amory—I would call attention to the fact that there are some cases of the municipal ownership of electric light plants in Maine—as at Lewiston, Bangor, and in some other cities—and if there is any gentleman here from that State, he might give us some information as to how the plan works there.

Mr. Harbison—I want to say a word further as to Dr. Amory's suggestion. His statement may apply to the electric light business, for of course almost any sort of people can go into the electric lighting business; but it requires men of intelligence and of training to properly manage a gas plant.

The President—Is there any one present from Maine or from Massachusetts who has felt the approach of a desire on the part of the public to control his own gas works?

Dr. Amory—I would like the privilege of giving some facts as to Chicago—

Mr. Stiness—And also as to Dunkirk.

Dr. Amory—I had hoped to have a letter to show to the Association to-day which gave the facts as to Dunkirk, and possibly I may get it by to-morrow. I have had no time to go there. I simply want to give from personal observation of two of the stations in Chicago a very low estimate of the cost of the investment. On a lot of land owned by the city of Chicago, on the corner of Chicago avenue and Seventh street, the city built a very substantial and useful building. The lot of land, as nearly as I could get at it from seeing it and from asking questions about it, is 70 feet wide by 100 feet deep; in other words, three city lots. I assume the value of that land to be \$6,000, which I presume is a very low price, but I do not know anything about the value of lots in that part of the city. The building and the chimney stack (which was a pretty substantial affair, and must have cost \$5,000 or \$6,000 to build) I valued at \$45,000. I think that is a very low valuation, and perhaps only 50 per cent. of what it ought to be. The three boilers with automatic stokers are very well set, and are in good order. The Westinghouse, Church, Kerr & Co., new boilers, are put at \$5,000. There are four 125-horse power engines, which I put at \$2,000 apiece, or \$8,000. Thirty miles of underground wire at \$8,000 per mile, or \$240,000. The conduit, which has six ducts, I was informed cost \$17.50 per linear foot. The cable cost 12 cents, and the hauling of that cable cost 4 cents; giving \$1.64 as the cost per linear foot for each duct. That would make \$8,000

per mile, and for 30 miles the investment would stand at \$240,000. Then, 250 dynamos and lamps, at \$60, would cost \$18,000. Steam fittings and miscellaneous investments, \$27,000. So that the whole plant of 250 lights might have cost \$350,000, according to my estimate; and I should think that you might safely add 25 or 50 per cent. to that. I have assumed the annual depreciation to be 10 per cent.; that would be \$35,000 per year, or for each of the 250 lamps \$150 per year. Each circuit is 3 miles long, and there are 10 circuits in all. There are 250 lamp posts, costing \$20 each; and 10 per cent. depreciation of the lamp posts would add \$500 more to the expense. Now, if the pay roll be assumed, from the experience at other stations, to be \$12,000 a year, the carbons \$3,600, the fuel \$10,000, the oil, waste, water, etc., \$4,400, it would make the expense of maintaining that station \$30,000, or \$120 per lamp per year. This added to the \$152 would make \$272 per year for each lamp. If we double the capacity of that station (and the station is large enough for 500 or 1,000 lamps), we should of course have to reduce for each lamp maintenance a sufficient proportion. The depreciation of course would not be so large, and the additional expenses would not be proportionally so much. The average expense for 300 lamps is assumed to be about \$160 per lamp per year, which is not 19½ cents per lamp. That station is not in operation. There is a station in operation where they have a very small space, and every spot of that space is occupied by something or other. They took an old fire engine house and adapted it to their purpose. Their investment, as I make it, is as follows: They have a Wright slow-speed engine, 275 horse power; shafting and friction without load, 57 horse power; so that they only get less than 220 horse power out of the machine. I estimated the cost of that engine and machinery. I put the land, building, machinery, boilers, dynamos, and lamps, and 50 miles of underground conduit, at the same price as before, making the total cost of the investment \$510,000. The labor, as given to me by their chief engineer, and by one or two other men in the station, was as follows: Chief engineer, \$1,200; assistant engineer, \$1,080; four stokers, \$2,880; six trimmers, \$3,240; line tester, \$720; three linemen, \$2,520; add to this for carbons, \$3,800; fuel, \$12,000; depreciation, \$51,000; making the total expense for that station per year \$78,640. That was for from 278 to 302 arc lamps, which was all that they furnished from that station. So that if my estimate is correct, the cost might be 75 cents per lamp per night. At Pittsburgh I went over the East End Electric Light Station, and although I have not transposed all my figures, I have them here in a notebook, and they may be interesting to those who wish the facts. The East End Electric Light Station has been established for three years. Until a year ago they had only 3,000 incandescent lights, and a very few commercial arc lights. This last year they are maintaining 400 arc lights and the 3,000 incandescent lamps have increased in one year to 14,000: and they compete with kerosene oil to a very limited extent, and with natural gas at 10 cents per 1,000, and with manufactured gas at \$1 per 1,000. So that Mr. Harbison need not feel quite so sure that gas is the only thing that is going to furnish light.

Mr. Harbison—He is not. The sun gives considerable light down our way.

Dr. Amory—We have got to use the sun, too. Their coal slag in Pittsburgh costs 4½ cents per bushel. For natural gas they pay 3 mills per horse power per hour. That Company never paid a dividend. They have invested \$300,000 in stock and \$150,000 in bonds, which is the extent of their power to contract debt. They still have orders for 100 arc lights which they cannot fill, and for 1,000 incandescent lights which they cannot fill. They have 270 miles of wire, and no underground circuit. They do their own wiring. They have this force: One engineer, who is a machinist and does the repairing, to whom they pay \$100 per month; three engineers, one of whom they pay \$3 per day, and the others \$2.50; two stokers, at \$1.75; two oil boys, who handle the distribution of the natural gas under the boilers, 75 cents per day. They have an 1,800-horse power engine capacity (a Westinghouse engine), and 1,360 boiler capacity at 80 pounds pressure. They have 15 linemen at \$2.75 per day; 7 ground men at \$1.75 per day; 1 foreman, at \$75 per month. They run an incandescent light circuit eight miles from their station.

Mr. Lamson—Are they making any money?

Dr. Amory—You will remember that the first year they only had 3,000 incandescent lights. They cannot possibly have made money except during the last year.

Mr. Lamson—When they are doing all they can hope to do, will they be able to make any money, or are they doing it for the fun of the thing?

Dr. Amory—They are doing as gas companies have often done—they are organizing their concern into a paying basis. I think their financial arrangements are well managed. They have bought real estate;

they have put up 270 miles of circuit; and, of course, they are under-capitalized.

Mr. Lamson—On such figures as you have given they cannot do business and make a profit.

Mr. Stedman—Allow me to suggest to Mr. Lamson that the primary object is not to make a profit on the sale of the light, but by that demonstration to sell a good deal more electrical apparatus.

Mr. Lamson—I want to know where the fun comes in.

Dr. Amory—I want to correct Colonel Stedman on that point. This Company is not to my knowledge owned by the Westinghouse people.

Mr. Stedman—They use Westinghouse machinery.

Dr. Amory—But I do not think it is under the Westinghouse people. I judge from what I heard the Westinghouse people are not in control of the stock. I will add that they charge six-tenths of one cent per hour for each 16 candle light, which is measured by meter; and they charge 25 cents per month for the use of that meter. I am only giving you the facts. Of course, I know nothing about their affairs. I want you to realize that a year ago they would only sell 3,000 incandescent lamps, and, of course, they could make no money. The past year they have sold 14,000 incandescent lamps and 400 arc lamps; for each of the latter they have received \$100 per year. They use natural gas for fuel, which costs 3 mills per horse power per hour, as against 8 or 9 mills here. I cannot give you any further information than that. It is only three years since they first began to do business. I can give you an estimate of their valuation: 3,450 poles, 50 to 60 feet in height, at \$10 per pole, will be \$34,500; 270 miles of wire, at \$160 per mile, would be about the same; 400 arc lamps and dynamos, at \$60 per lamp, would be \$24,000; one 1,800-horse power engine, reckoned at \$15 per horse power, would be \$27,000; their boiler, 1,400-horse power, at \$10, would be \$14,000; their land and buildings, etc., \$125,000. They have a whole block. They own this land. Their contingencies would make their total investment cost, as I valued it, \$300,000. They have an alternating plant of 15,000 lights, which, at \$8 or \$9 a lamp capacity, would make \$420,000, and their whole investment would, therefore, be about \$450,000. I do not see but that that comes out pretty fairly. I presume that next year they will make some money. I do not see why they should not.

The President—The discussion has drifted somewhat away from the original subject. While we recognize the necessity of becoming acquainted with these details, I think we had better pass over this discussion, as we have so many other papers before us for consideration.

Mr. Harbison—I think the Association is under obligations to Dr. Amory (I am sure I am) for the time that he has taken to gather these statistics and to prepare this paper, which is interesting, to say the least. I move the thanks of the Association be tendered him for his kindness in the matter. [Adopted.]

(To be continued.)

SPECIAL ENGLISH CORRESPONDENCE.

COMMUNICATED BY NORTON H. HUMPHRYS.

SALISBURY, Feb. 10, 1890.

The Gas Stokers Strike in South London—The Gas Light and Coke Company Gas Testing in London—Gadd and Mason's Gasholder Construction.

The strike of stokers in South London has been brought to a close, and in a manner that is simply farcical. The various labor Unions, concerned have come to an agreement (?) with the Directors of the South Metropolitan Gas Company on two conditions. These are that the Company shall revert to the eight hour system as in operation before the strike, and that preference shall be given to former workmen in the case of any vacancies arising. This is the sum and substance of all that is gained by the recent strike. This is the total benefit that the "Union" is able to secure for its members. Yet the officers of the various Unions undertake, upon the acceptance of them, to declare the strike at an end. The farcical nature of the whole thing will be evident, when we remember that neither of these conditions touches upon the points in dispute. The company had previously adopted the eight hour shift and got it fairly into working order. Throughout the dispute there has not been the slightest hint of any fears on the part of the men, as to its rejection. So far from making things hot for their old workmen, the Company were doing their best to satisfy them, and would not, but for the action of the men themselves, take a single new hand, to the detriment of an old one against whom no fault could be laid. The only advantage, then, that the Union has secured for the men, is the stipulation that they shall have the preference when any vacancies arise, a stipulation which is of very little value at this time of

the year. Mr. Livesey has already explained that he has worked the two-shift system during the emergency, but is willing to return to the three shifts as soon as he can get into regular working. But then there are the new men. It was of course necessary to offer every inducement in the shape of promise of regular employment, in order to secure a sufficient number of new men when the old ones left. And these new men have now the first claim, so that the Directors could not honorably turn them off in order to take on old hands. The conclusion, therefore, appears unavoidable, that at the best there are not likely to be vacancies for more than one-third of the strikers, and that even this cannot occur until next winter. And then, that many will only be able to secure temporary work as "winter hands." It also appears that the official agreement (?) has been forestalled by a private understanding between Mr. Livesey and several of the men who have sent in their names as willing to return. Mr. Livesey states that a list of these has been kept, and that all vacancies that arise are supplied from it. This is the end of the great strike. The Stokers' Union, in order to preserve itself a habitation and a name, is obliged to go through the form and agreement that secures nothing for its members. It not only leaves them in the same position as they were before, but lamenting the loss of good situations, thrown up at the bidding of the Union, and lost without the receiving of a single benefit in return.

It only seems a few days ago that the officers of the "Union" were talking, not only of stopping the gas supply in London, but also the coal, to say nothing of other inconveniences that were to be inflicted on the British public, as a means to the securing of their ends. Indeed, one almost fancied that the old inquisition was to come again in another form, and that the public were to be worried and tortured to an unlimited extent, in order to force them to obey the behests of the Union, or to use their influence in furthering its desires. All these bubbles are now pricked and have vanished. Many people will bring forward theories to account for the collapse of the Union, and I would venture to suggest one. That is, because they have done so much unnecessary business on Sundays. No one knows better than gas engineers that certain work must of necessity be done on that day; but when we find a society—let its objects be what it may—making a practice of utilizing Sabbath after Sabbath as regular field days, to the utter disturbance of all associations usually connected with that day of the week, we may safely prophesy that the objects of that society are not likely to prosper. It is a remarkable thing that those gas undertakings which have been foremost in diminishing Sunday labor as far as practicable, are without exception amongst the most prosperous in the country. For a striking example one need not go further than the one just under discussion—the South Metropolitan Gas Company.

At this early period of the year only a few gas undertakings have completed the preparation of their accounts for the last half of 1889. Amongst the first to appear, as usual, are those of the Gas Light and Coke Company; and the information which the Directors bring forward is of a satisfactory character, notwithstanding various little troubles. They are again able to pay full dividends, and have experienced a large increase—more than 5 per cent. as compared with last year—in the sale of gas. This is chiefly ascribed to the extended use of gas stoves for heating and cooking. During the half year they have sold 2,600, and let on hire nearly 5,600 stoves, in addition to those previously disposed of, showing a large and rapid development in the use of gas as fuel. The recent reductions in the price of gas, together with the increased price of coal, are no doubt concerned in this to some extent. With coal at present prices, a high quality heating gas at 60 cents per 1,000 cu. ft. is a comparatively cheap fuel. A considerable extension in the manufacturing, storing and distributing plant will shortly be necessary. The Directors have to contend with increased prices of coal, iron, fireclay and all kinds of materials and stores, besides a very substantial addition of about \$750,000 per annum to the wages account. It is a somewhat disappointing commentary on this liberal treatment of their workmen, that the yield of gas per ton of coal has scarcely been so good. In noticing the result of Mr. Trewby's recent visit to the United States, the Directors say that although enriched water gas is not likely to replace coal gas in England, it may be found useful to provide for the manufacture of water gas, to be used in addition to and in conjunction with coal gas on occasions when a large quantity of gas is required to meet a sudden demand. They are about to conduct experiments on the practical scale in this direction, and also in regard to processes for improved carbonization and dealing with residuals. The Dinsmore process and the inclined retort are probably in view here.

I have on several occasions commented on the work of examining the gas supply in London, as carried on under the superintendence of the Gas Referees. Although the operations in this department are of an

extensive character, costing several thousands per annum, it is surprising how seldom they are referred to in public. If a speaker at a meeting wants to refer to the quality of the gas supply, he usually indicates it by adjectives of his own choosing, just as he might do if it was never officially tested at all. In the public press also, it scarcely ever happens that the quality of the gas is indicated by a reference to the weekly returns of the Superintendent Examiner. The whole is, therefore, only a costly way of playing watch dog upon the gas companies. The Referees also, do not appear fortunate in their relations with the suppliers, or with their own staff. They have offended the former by introducing alteration in the apparatus, which are said to have the effect of considerably deteriorating the apparent value of the gas, and at the same time to be beyond the limits contemplated by the Parliamentary regulations. The amended instructions to the Examiners have had a somewhat similar effect, in that these gentlemen are called upon to devote a much larger space of their lives and attention to their duties, while at the same time nothing has been said about an increased salary. Having really doubled the work, the Referees should have recommended a proportionate increase of remuneration in the proper quarter. The result is that the staff has combined together and forwarded a spirited memorial to the County Council, asking for the adoption of a standard more accurate than the sperm candle at present used, and also for an adequate increase of salary. The fact that, according to the showing of their own superintendent, the results recorded by the Examiners are not of a reliable character, on account of the deficiencies of the sperm candle, in no way detracts from the labor of obtaining those results, and these gentlemen are quite in order in asking for a proper recognition of their skill, patience, and time, that are indispensable to the efficient carrying out of the very elaborate instructions issued by the Gas Referees.

A gasholder without columns, girders, or other external guide framing, has lately been erected at Northwich. It is provided with Gadd and Masous spiral guides, to which I have referred on a previous occasion. The diameter is 60 ft., and there are two lifts each 20 ft. high. At equal distances round the inside of the tank are fixed the guide rails, eight in number, placed against the tank wall at an angle of 45°. A similar series of guides are fixed on the interior of the outer lift for the guiding of the inner lift. The pulleys are made of steel and are 10 in. diameter, working on 2 in. iron axles. The inner pulleys are faced solid, and run in the trough of the guide, which is H shape in section. But those on the outside are grooved, so as to take the outer edge of the guide.

These particulars are taken from a description of the holder furnished to the *Journal of Gas Lighting* by Mr. Thos. Newbigging, C.E. It is estimated that the actual saving in weight of metal used is 34 tons, and this could be increased in future structures of the same kind, seeing that the present holder is somewhat in the way of a new departure, and has, therefore, been made stronger in several parts of the framework than the experience which it has been the means of affording shows to be necessary. The saving in cost of ironwork is put at about \$3,000. The tank is also cheaper, as there is no excavating for piers, no brickwork for same, and no base stones for the columns. The pressure given by the holder when full is 7 inches, of which 4½ inches is furnished by the bottom lift. The holder has been observed whilst under the influence of the strong gales that have recently occurred, and whilst nearly full of gas. It has not shown any movement worth recording. The Northwich holder may, therefore, be taken as a practical demonstration of the truth of the principles first enunciated by Mr. Wm. Gadd. It has been shown to a party of about 100 gas engineers from different parts of the country, who found it fully inflated on their arrival at the works. After thoroughly inspecting it while in this condition and receiving any desired information from Mr. Newbigging and Mr. Gadd, who were present, connection was opened with another holder, and it was allowed to empty itself in the presence of the company. The action of the apparatus was pronounced to be satisfactory in every way.

At a meeting of the Malden (Mass.) Board of Aldermen one of the things considered was the annual appropriation bill. When it was reached Alderman Russell moved that the sum of \$18,000 be substituted for \$16,500 on account of street lights, giving as his reason therefor that in case such action were not taken the city could not add to the electric lighting service, and thought that the price charged (\$90 per annum for each arc burned 300 nights per year) was not excessive. Ald. Devir objected on the ground that Chelsea paid but \$80 per annum for arcs burned every night in the year. The Russell amendment was then rejected.

ITEMS OF INTEREST FROM VARIOUS LOCALITIES.

THE ordinance introduced in City Councils of St. Louis, which subsequently received the indorsement of both branches of the government, limiting the price which gas companies might charge for gas to 90 cents per 1,000 foot, has been vetoed by Mayor Noonan. The message announcing this action is reasonable, and so unlike the fulminations of the ordinary city authority when dealing with gas supply, that we reproduce it in full. "I herewith return Council bill No. 44 without my approval. This measure was introduced into the Council on May 10, 1889. It passed that body on July 26, 1889, establishing the price of gas, on and after February 1, 1890, at \$1.18½ per 1,000 cubic feet. At this time the price of gas was, in this city, except in a small territory, \$1.50 per 1,000 cubic feet. In the House of Delegates the bill was considered and so amended, as to establish for 5 years the price of illuminating gas at 90 cents per 1,000 cubic feet, and fuel gas at 50 cents per 1,000. In this shape it passed the House of Delegates, on January 7, 1890. The Council concurred in the amendments and adopted the amended bill on February 7, 1890. In the meantime, on January 1, 1890, the gas company reduced the price of gas to \$1.18½ per 1,000 cubic feet, the price originally placed by the Council, at which price it is now sold to consumers. The power to regulate the price of gas, conferred on the city by its charter, is to be exercised in a reasonable manner; and an ordinance on the subject that is deemed unreasonable by the courts will be held to be invalid and of no force or effect. Taking the price at which the article is sold in the principal cities of this country, which in no case is lower than \$1.25 per 1,000, I do not think St. Louis is justified in demanding coal gas for illuminating purposes at 90 cents per 1,000 cubic feet. The policy of the local government should be to encourage business pursuits and enterprises by not interfering with or hampering them, save in cases where the necessity of municipal action for the protection of the community is obvious. By abstaining from exercising the power to regulate, except in the cases above indicated, a stability and tone are given to investments of capital in this city, and the prosperity and welfare of the community are correspondingly enhanced and augmented. I have during my administration endeavored to act on the above policy, believing it to be fraught with world-wide benefits to St. Louis, and, in the view I take of the matter before me, I cannot give my approval to Council bill No. 44.—EDWARD A. NOONAN, Mayor."

THE Laclède Gas Company have determined to build eight benches of 7's, on the Coze inclined plan. It is hoped to have the settings in operation next May, during the time of the Western Association meeting; and as the first foundation stone is still unplaced, it will be readily seen that Engineer Egner and his assistants will have to keep the contractors moving all the time, if the Western Association is to witness the trial run. It also strikes us that the proprietors of the Laclède Company are to be congratulated on their pluck in determining to make such an extensive trial of a system that still requires time to demonstrate thoroughly its merits.

THE Citizen's Gas Light Company, N. Y., will, at a meeting set for the 12th inst., act upon a proposition to increase the capital stock of the Company from 60,000 shares to 75,000 shares, or an increase in money value at par (\$20) of \$300,000. We understand that the Company will, at the termination of its current contract with the Fulton-Municipal Company, manufacture its own gas on the old works site in South Brooklyn, under the Meeze patents and systems.

THE Directors of the San Jose (Cal.) Light and Power Company have adopted resolutions looking to plant betterment, that will involve an expenditure of \$75,000. The holder contract (vessel to have a capacity of 150,000 cubic feet) has been awarded to the Stacy Manufacturing Company. This looks as if gas were holding its own on the Pacific coast district.

THE proprietors of the Corning (N. Y.) Gas Light Company have decided to engage in the supply of electric currents. The Thomson-Houston system has been chosen, and the installation is to be in working order by May 1.

WE understand that the gas and electric light plants at Evansville, Ind., have been purchased by the U. G. I. Company, which will operate the same hereafter.

MR. RICHMOND E. SLADE, of the White Plains (N. Y.) Gas Company, is a bachelor no longer, having been united in marriage, on the evening of

Feb. 12, to Miss Jennie A. Wiggins, daughter of the late H. S. Wiggins, of Yonkers. May their lot be a happy one.

ONE result of the recent astounding bank developments in this city will be in all probability the postponement of the completion of construction work on the plant of the Empire Gas and Electric Light Company, of Huntington, L. I. President Claassen, whose management of the Sixth National Bank brought him plenty of notoriety at least, was at the head of the Huntington enterprise.

MR. D. W. CRAFTS, of Northampton, Mass., was one of the "regulars" who failed to answer his name during roll-call at the New England meeting. Perhaps his non-appearance may be explained in the statement that an explosion occurred at the Northampton works on the night of Feb. 16. The damage to property, however, was slight, and no one was injured.

S. A. BAXTER, whose connection with the National Oil Company, of Lima, Ohio, is well known in the West, has instituted suit against the St. Paul (Minn.) Gas Company for \$54,168 in the United States Circuit Court, alleging breach of contract as the basis for the action.

SENATOR POYNTZ, we understand, has secured the adoption by the Kentucky Legislature of the following resolutions, which savor very strongly of a "strike" at the proprietors of the Louisville Gas Company:

"Whereas, Through the public prints, and in general comment, statements have been made to the effect that the Louisville Gas Company, a corporation chartered by the General Assembly of Kentucky, is openly, seriously, and flagrantly violating many provisions of its charter; and

"Whereas, The said Louisville Gas Company has by such violations forfeited its charter; and

"Whereas, It has been commonly rumored that the Louisville Gas Company has not kept faith with the city of Louisville in the quality of light furnished, nor with its patrons in the price charged for fuel and other gas; and

"Whereas, It is a matter of public notoriety that the said Gas Company has attempted to interfere with the election of local and State officers by the illegal use of money; therefore be it

"Resolved by the General Assembly that a committee of five from the Senate and five from the House be appointed to investigate the affairs of the Louisville Gas Company; to summon witnesses and swear the same; to examine its books, and to be invested with full power to carry out the spirit of these resolutions, and report the result of such investigation to this body."

It is possible that these resolutions were brought about by the malice of the Louisville Electric Light Company, whose proprietors are anxious that the Legislature should refuse to grant the electric light charter which the Gas Company has been endeavoring to secure. It might be well to add that the authorities of Louisville favor the legislation asked for in this respect by the Gas Company.

WE regret to announce the death of Mr. Joseph Alphonse Pagaud, who has acted as Secretary of the Jefferson City (La.) Gas Company since a controlling interest in that enterprise had been secured by the firm of Jackson & Kilpatrick. Mr. Pagaud's death occurred on the morning of Saturday, Feb. 15.

THE Provincial Legislature has refused to indorse the application for an opposition gas charter for Montreal, Canada.

A CORRESPONDENT sends the following: "H. H. Button, one of Milwaukee's oldest and most highly respected citizens, died at his home in Milwaukee on the morning of February 14th. He came to Milwaukee when a youth, and for many years has been a prominent figure in its business and social circles. He was President of the Milwaukee Gas Light Company, and was senior member of the wholesale drug house of Green & Button. He was very well liked.—T. R."

THE proprietors of the Tallahassee (Fla.) Gas and Electric Light Company are greatly elated over the business outlook.

A VERY peculiar suit is that which has been brought before Judge Hawes, Chicago, by one John Larson, who sues the Chicago Gas Light and Coke Company for \$5,000, because of injuries received by him in a gas explosion at No. 730 Sedgwick street, May 2, 1888. He claims that the Gas Company neglected to turn the gas off, though the premises had

just been vacated by a tenant who had taken away the gas fixtures. The Company's defense was that the explosion was caused by Larson's carelessness in lighting a match.

MR. JACOB NICHOLS, who was largely interested in the fortunes of the Lowell (Mass.) Gas Company, is dead. His demise occurred on the morning of February 16th, was in his 75th year, and was prominently identified with many important local interests.

"THE city of Oshkosh (Wis.) was served with a notice about a fortnight ago by the Oshkosh Gas Company, through its attorneys, Finck & Barber, which in effect is that the Gas Company has wearied of waiting for an answer to the complaint served upon the city some months since, and it will now proceed to take the depositions of scientists or authorities upon the subject of electric lighting in Chicago, Milwaukee and other cities as to the relative merits of the lights furnished by the Gas Company and the Oshkosh Electric Light and Power Company. Suit was commenced by the Gas Company about three months ago against the city and Aldermen of the second ward to show cause why the contract for lighting that ward was not awarded to plaintiff—the lowest bidder; and to compel the defendant to award such contract. The Company claims that by reason of a franchise granted to the Company, of which the Oshkosh Gas Company is the legal successor, it is alone entitled to light the streets of the city. The authorities have simply slighted all the former notices served on them, evidently believing that the Gas Company did not intend to push matters. Now, however, they perceive their mistake. The second ward Aldermen justify their action in letting the contract for lighting in that ward to the Oshkosh Electric Light and Power Company on the ground that the light furnished by the latter Company is far superior to that supplied by the Gas Company. The latter employs the Thomson-Houston system, while the contractors are working under the Brush plan. In my opinion the Gas Company has a good case, and will eventually prove it in the courts to the confusion of the local authorities.—R. E."

IT is more than probable that a gas plant will be erected at Darien, Ga., this spring. This place is the capital of McIntosh county, Ga., and is on the Altamaha river, at a point about 62 miles southwest of Savannah.

THE proprietors of the Electro-Carbon Motive Company, of Chicago—perhaps the concern would be more readily identified under the name of the Baker Gas Engine Company—have decided to put in their manufacturing plant at Aurora, Ills. The Company manufactures gas and gasoline engines and all sorts of electric motors.

"THAT's derved fine," said Farmer Squedunk, as he gazed up at the sign, "Teeth extracted without pain—gas administered." "That's very pooty. I've got the blamedest, ornierest toothache ever was; I read papers, I do, and I know that derved gas trick. Put you to bed and turn on the gas. Next day there is an inquest and a verdict, 'Another fool countryman gone.'"

ARTICLES incorporating the Berkeley Development Company have been filed by Messrs. Geo. W. Kline, Louis Gottshall, W. E. Sell, A. Gunn, and J. L. Scotchler. It is capitalized in \$500,000, and one of its objects is "to operate, lease, etc., all systems, plans or plants in producing light and heat by gas, electricity, etc." Berkeley is a post village of Alameda county, Cal., near the Bay of San Francisco, and is about midway of the latter city and Oakland. It ought to be a good place wherein to operate a gas company.

THE Cicero Gas Company—managed by Messrs. Geo. H. Parks, Henry Frink, C. E. Crafts, J. J. Walsler, F. L. Ball, H. J. Ullman, S. A. Rothermel and Dr. W. C. Gray—asks for a charter to supply gas for light and fuel in the town of Austin, Ills. The proprietors say they will employ the process in use at Jackson, Mich., and the selling rates are to be \$1.50 per 1,000 for illuminating, and 50 cents per 1,000 for heating gas.

THE Lowe type of plant recently installed at Hutchinson, Kas., under the supervision of Mr. Mudie, has answered the tests applied to it satisfactorily.

AT the annual meeting of the Petersburg, Va., Gas Light Company, the following officers were chosen: President, John G. Dunn; Superintendent and Secretary, W. H. Baxter; Treasurer, W. F. Spottiswode; Directors, Alexander Donnan, Dr. H. G. Leigh, John McGill, Nelson

T. Patterson and David Dunlap. The annual reports were indicative of the Company's prosperity.

AT the annual meeting of the Augusta (Ga.) Gas Light Company the President—the Hon. Geo. T. Barnes—was unavoidably absent because his duties as a Congressman required his presence in Washington. His report for the year, however, was read, and it gave general satisfaction. At the election for officers the following result was reached: President, Hon. Geo. T. Barnes; Secretary, H. B. Adams; Directors, G. T. Barnes, P. Walsh, T. G. Barrett, E. R. Schneider and P. H. Langdon. The stockholders authorized the Directors to subscribe \$200 to the exposition, provided the requisite \$60,000 was raised.

THE Senate Committee on General Laws of the State of Virginia has consented to important amendments to the charter of what is known as the Southside Land and Improvement Company. Under the amendments the Company is empowered to construct and operate gas works at Manchester (opposite Richmond) Va., and we understand that that provision will be taken advantage of at an early date.

THE Atlantic City (N. J.) Gas and Water Company has announced a reduction in gas rates to \$1.50 per 1,000 cubic feet.

IN connection with the buncombe resolutions and action authorizing the investigation of the affairs of the Louisville (Ky.) Gas Company by a special committee of the State Legislature, it will be remembered that one of the assigned reasons for the appointment of the committee is the reported bad quality of the gas that is distributed. Louisville has an official gas inspector—Col. Phil. Bate—who has made careful tests of the gas at least once a week since his appointment to office; and his figures invariably show that the quality of the gas is considerably in excess of the legal requirements as to candle power and purity.

IN their estimate of the probable receipts and expenses in the operation of the city gas works at Wheeling, West Va., the Board of Gas Trustees and the Council Committee on Light state that the former are likely to be \$98,000, while the latter are put at \$114,806. As the cash balance from 1889 was \$16,972.28, this would leave a surplus at end of year of \$166.28. In the estimate, however, liberal provision is made for "improvements," the sum of \$16,101 on this account being made up as follows: Resetting 12 benches of 6's, \$4,000; 4 new benches of 6's, \$8,000; general repairs, \$650; repairs to No. 3 holder, \$300; 1 street main governor, \$600; 2 sets lime trays, \$351; 1 exhaustor, engine, etc., \$2,200.

THE Syracuse (N. Y.) *Courier*, of Feb. 21, contains the following: "The Common Council met at 4 o'clock yesterday afternoon, with Mayor Kirk in the chair. The first thing done was to pass a resolution granting a franchise to the Onondaga Gas Light Company. The resolution was introduced by Ald. Matty. After it was read a motion was made that the resolution be adopted. Ald. Klock amended that the resolution be tabled. The amendment was put to vote and lost, and then the adoption of the resolution was voted on and carried. Aids. Small, Matty, Candee, McAuliffe, Segler and Scanlon voted in favor of it, Aids. Klock and Finnegan voted against it. Ald. Wilken was excused from voting, and Ald. McLennan was absent. The franchise allows the Company to lay pipes through the streets within the limits of the city of Syracuse for illuminating and heating gas. No street or pavement can be torn up without 10 days' notice, and no street paved with asphalt can be torn up by the Company without a permit from the Common Council. While laying its pipes the Company shall make a weekly report of streets and pavements torn up and work done. The Company shall furnish 20-candle power light at a rate of \$1.25 per 1,000 cubic feet to the city, and at a rate not to exceed \$1.40 per 1,000 cubic feet to the inhabitants. Before the streets are torn up a bond of \$35,000 shall be deposited with the City Clerk to protect the city against loss from any action of the Company. The Company must not dispose of or sell its plant except to the city, and must not combine with any other company or persons for the purpose of controlling the price of gas, or of gaining power thereby. Pipes are to be laid through any street whenever the Common Council shall direct." In plain language this is an outrage on the vested rights of the old Syracuse Company, whose proprietors have carried on their business with rare fidelity to the best interests of the local gas consumers. We understand that Mayor Kirk has signed the ordinance, and it is not at all unlikely that the passage of the ordinance may hereafter become the subject of legal inquiry.

[SINCE the above was put in type, we hastened to place ourselves in communication with a gentleman (a resident of Syracuse), whose know-

ledge of the facts and factors connected with this brazen deal, being voluminous and accurate, would enable us to give ourselves the precise standing of the position. Thanks to his promptness and courtesy, we can say (and very much to our satisfaction) that the schemers seem to have overreached themselves completely. To employ our correspondents words: "SYRACUSE, N. Y., Feb. 25th: Our charter election occurred on Tuesday last (18th inst.), when the then Mayor and some of the 'combine' Aldermen were defeated. At a meeting of the old Council—held on Thursday last, they, in a clandestine manner and with closed doors—no one was notified of the meeting, except those who had been *induced* to vote—passed resolutions granting a franchise to the new company. This action brought out an universal protest from our citizens; and everybody condemned the proceedings. The Mayor, who up to this time had been opposed to granting a franchise to the new company, was deceived and cajoled into allowing it to go through, found himself in a hole, from which he tried to raise himself, but failed, as the 'combine' of his Council had gone beyond his control. The newly-elected Mayor and Council were inducted into office last evening, and promptly rescinded the resolutions and annulled the franchises granted on Thursday; the vote was 7 to 3—one member was excused from voting. There are now 7 good, square, honest men in the Council of 11. Hence the old Syracuse Company is still in possession of its own. I cannot tell what may be the outcome, but I do not think the opposition will attempt any legal proceedings, for their local agents have not only 'given them away,' but the old company must have strong points against them, which could no doubt be made with telling force." One other point we would like to make in connection with the passage by the former Council of the opposition ordinance, and that is, the cowardice of the schemers, who met to clinch the "agreement" during Mr. A. C. Woods absence from Syracuse, or when he was attending the meeting of the New England Association. However, all's well that ends well.]

ELSEWHERE we note a damage suit against the Chicago Gas Light and Coke Company, brought by one Larson for injuries received in a gas explosion. The jury awarded complainant \$1,500. The case will be appealed.

AT a recent meeting of the Dallas (Texas) City Council an ordinance which sought to name maximum rates for gas and electric lighting was considered. Mr. Kivlen moved to file the bill—this, we understand, is equivalent to the defeat of any measure so disposed of—which, after some opposition, was adopted. Mr. Loeb, in opposing the ordinance, made the following inquiry: "What would my colleague from the Fourth Ward say if I should offer an ordinance compelling him to sell his beer at 2½ cents per glass; or \$1.50 per keg?" The member from the Fourth mumbled something about private interests and public corporations, and retired to ruminate.

IN an explosion in the purifying house of the Owen Sound (Canada) Gas Company, which occurred on the afternoon of February 22, an employee named Nelson was killed, and the works were damaged in \$500.

THE Pueblo (Cal.) Gas and Electric Light Company is increasing the capacity of its arc lighting plant.

THE Highways Commissioners (Flatbush, L. I.) have refused to renew the contract for public lighting with the local Gas Company, on the ground that the rate submitted—\$28 per lamp per annum, which is identical with that of last year—is too high. In the meantime the Company will carry on the lighting, until such time as the matter is adjusted, on the basis of the old rate.

THE plant of the Mauch Chunk (Pa.) Gas Company was damaged by an explosion on the afternoon of February 21st.

ARTICLES incorporating the Aspen (Col.) Economic Gas Company have been filed by Messrs. W. C. Pettibone, Geo. W. Hill, A. H. Pettibone, Henry Webber and J. M. McMichael. It is capitalized in \$25,000.

MESSRS. STEVENSON, Kingman, Walsh and others have applied to the St. Louis House Committee of Public Improvements for favorable recognition of a project to supply illuminating and fuel gas in that city. They agree to charge not in excess of 45 cents per 1,000 for heating and 75 cents per 1,000 for illuminating gas, to give the city 10 per cent. of the net receipts, and to file a bond in \$100,000 that their pledges shall be carried out.

The Market for Gas Securities.

Consolidated gas shares were inclined to the weak side in the interim of our last report, although values were not materially affected. It is undeniable, however, that there was a marked absence of any elasticity in the trading, which was about all effected at a concession from the rates of a fortnight ago. To-day (Friday) the quotations at noon were 95½ to 96. Other city shares, notably Mutual and Standard preferred, were disposed seemingly to go somewhat above prior prices, and this tendency was very marked in respect to Standard preferred, which was bid for freely at 87, while holders insisted on at least 89. The common stock was also in demand, many a nibble at 43 to 46 being recorded. While the preferred may offer a fair chance to investors, we should be chary at advising a purchase of the common. Brooklyn shares are strong, and the thing of moment in that city is the proposed increase in Citizens Company capital, the figures anent which are to be found in our current item columns. It would seem as if the Company had determined to rehabilitate and work its plant, (which as to the district to be supplied is most advantageously situated) on its own account, instead of being willing to figure as a peddler. We congratulate Engineer Byrne on this determination. He has talent, and will now have a chance to make money for his Company.

Chicago Trusts are about as before, and it is generally agreed on that the usual dividend will be declared this afternoon. Laclede common is weaker, at 14½ to 15½, and Baltimore Consolidated has again moved up to the figures of a fortnight ago. The bonds offered by the syndicate now in control of the San Diego (Cal.) works seem to have found favor with investors, the issue having been about all absorbed on the proprietor's terms.

Gas Stocks.

Quotations by Geo. W. Close, Broker and Dealer in Gas Stocks.

16 WALL ST., NEW YORK CITY.

MARCH 3.

All communications will receive particular attention.

The following quotations are based on the par value of \$100 per share.

	Capital.	Pa.	Bid	Asked
Consolidated.....	\$35,430,000	100	95½	96
Central.....	500,000	50	—	—
“ Scrip.....	220,000	—	—	—
Equitable.....	4,000,000	100	119	122
“ Bonds.....	1,000,000	—	113	115
Harlem, Bonds.....	170,000	—	—	—
Metropolitan, Bonds....	658,000	—	116	118
Mutnal.....	3,500,000	100	110	—
“ Bonds.....	1,500,000	—	100	102
Municipal, Bonds.....	750,000	—	—	—
Northern.....	—	50	—	—
“ Bonds.....	150,000	—	—	100
Standard Gas Co.—				
Common Stock.....	5,000,000	100	45	—
Preferred.....	5,000,000	100	87	90
Yonkers.....	—	50	112	—
Richmond Co., S. I.....	346,000	50	—	—
“ Bonds.....	20,000	—	—	—
Gas Co's of Brooklyn.				
Brooklyn.....	2,000,000	25	109	111
Citizens.....	1,200,000	20	68	70
“ S. F. Bonds... ..	320,000	1000	100	103
Fulton Municipal.....	3,000,000	100	121	124
“ Bonds....	300,000	—	100	105
Peoples.....	1,000,000	10	80	82
“ Bonds (5's).....	368,000	—	100	—
“ “ (6's).....	94,000	—	100	—

Metropolitan.....	1,000,000	100	93	96
Nassan.....	1,000,000	25	115	—
“ Cfts.....	700,000	1000	120	122
Williamsburgh.....	1,000,000	50	120	123
“ Bonds... ..	1,000,000	—	108	112
Out of Town Gas Companies.				
Boston United Gas Co.—				
1st Series S.F. Trust	7,000,000	1000	93	93½
2d “ “ “	3,000,000	1000	71	72
Bay State Gas Co.—				
Stock.....	5,000,000	50	24	25
Income Bonds.....	2,000,000	1000	—	—
Buffalo Mutual, N. Y... ..	750,000	100	90	95
“ Bonds... ..	200,000	1000	95	100
Citizens, Newark.....	1,000,000	50	155	160
“ “ Bonds.	45,000	—	—	—
Chicago Gas Trnst.....	25,000,000	100	46	46½
Chicago Gas Light. & Coke Co.—				
Gr'd Gold Bonds	7,650,000	1000	—	93½
Equitable Gas & Fuel Co., Chicago, Bonds	2,000,000	1000	97	—
People's Gas and Coke Co., Chicago—				
1st Mortgage.....	2,100,000	1000	—	99
2d “ “	2,500,000	1000	96	100
Consumers Gas Light Co., Jersey City.....	2,000,000	100	15	25
Bonds.....	600,000	1000	80	—
Cincinnati G. & C. Co..	6,000,000	100	201	203
Consumers Toronto....	1,000,000	50	190	200
Central, S. F., Cal.....	—	—	80	90
Capital, Sacramento, Cal	—	—	58	—
Consolidated, Balt.....	11,000,000	100	54	54¼
“ Bonds....	6,400,000	—	107	107½
Hartford, Conn.....	750,000	25	102	108
Jersey City.....	750,000	20	186	190
Laclede Gas Light Co., St. Louis, Mo.—				
Common Stock....	7,500,000	100	14½	15½
Preferred “	2,500,000	100	—	—
Bonds.....	9,034,400	1000	84½	—
Louisville, Ky.....	2,570,000	50	125	130
Little Falls, N. Y.....	50,000	100	—	100
“ Bonds	25,000	—	100	103
Montreal, Canada.....	2,000,000	100	200	208
Memphis (Tenn.) Gas... ..	750,000	100	48	51
“ Bonds.	240,000	100	103	—
New Haven, Conn.....	—	25	200	—
Oakland, Cal.....	—	—	35	35½
Peoples, Jersey City... ..	—	—	60	61
“ “ Bonds..	—	—	—	—
Paterson, N. J.....	—	25	99	102
Rochester, N. Y.....	—	50	99	100
Syracuse, N. Y.....	500,000	25	—	—
San Francisco Gas Co.	—	—	—	—
San Francisco, Cal.....	10,000,000	100	55½	55¾
Washington, D. C.....	2,000,000	20	200	208
Wilmington, Del..	—	50	88	90

Advertisers Index.

GAS ENGINEERS.		Page
Jos. R. Thomas, New York City		304
Wm. Henry White, New York City		307
Wm. Mooney, New York City.....		304
William Gardner, Pittsburgh, Pa.....		304
Fred. Bredel, N. Y. City.....		303
GAS WORKS APPARATUS AND CONSTRUCTION.		
James R. Floyd & Sons, New York City		307
Continental Iron Works, Greepoint, L. I		307
Deily & Fowler, Phila., Pa.....		307
Kerr Murray Mfg. Co., Fort Wayne, Ind.....		295
Stacey Mfg. Co., Cincinnati, Ohio.....		307
Bartlett, Hayward & Co., Baltimore, Md.....		305
Morris, Tasker & Co., Limited, Phila., Pa.....		305
Davis & Farnum Mfg Co., Waltham, Mass.....		295
R. D. Wood & Co., Phila., Pa.....		306
Bouton Foundry Co., Chicago, Ills		307
Smith & Sayre Manufacturing Co., New York City.....		306
Fred. Bredel, N. Y. City.....		303
United Gas Improvement Co., Phila., Pa.....		297
Henry Pratt & Co., Chicago, Ill.....		303
National Gas Light and Fuel Co., Chicago, Ills.....		298
Simpkin & Hillyer, Richmond, Va.....		292

GAS AND WATER PIPES.

Gloucester Iron Works, Phila., Pa.....	304
Mellert Foundry and Machine Co., Reading, Pa. (John Fox, Selling Agent, N. Y.).....	304
Ohio Pipe Co., Columbus, Ohio.....	304
M. J. Drummond, New York City.....	304
R. D. Wood & Co., Phila., Pa.....	306
Warren Foundry & Machine Co., New York City.....	304
Donaldson Iron Co., Emaus, Pa.....	304
Dennis Long & Company, Louisville, Ky.....	304

PROCESSES.

National Gas Light and Fuel Co., Chicago, Ills.....	298
Bartlett, Hayward & Co., Baltimore, Md.....	305
Wm. Henry White, N. Y. City.....	307
United Gas Improvement Co., Phila., Pa.....	297
Henry Pratt & Co., Chicago, Ill.....	303
The Fuel Gas and Light Improvement Co., N. Y. City.....	292

INCLINED RETORTS.

Laclede Fire Brick Manuf'g Co., St. Louis, Mo.....	259
--	-----

GASHOLDER TANKS.

W. C. Whyte, New York City.....	298
J. P. Whittier, Brooklyn, N. Y.....	299

GASHOLDER PAINT.

The Government Waterproof Paint Co., Boston, Mass.....	292
--	-----

RETORTS AND FIREBRICK.

J. H. Gautier & Co., Jersey City, N. J.....	302
B. Kreischer & Sons, New York City.....	302
Adam Weber, New York City.....	302
Laclede Fire Brick Manuf'g Co., St. Louis, Mo.....	302
Brooklyn Retort and Fire Brick Works, Brooklyn, N. Y.....	302
Borgner & O'Brien, Phila., Pa.....	302
James Gardner, Jr., Pittsburgh, Pa.....	302
Henry Maurer & Son, New York City.....	303
Chicago Retort and Fire Brick Co., Chicago, Ills.....	302
Baltimore Retort and Fire Brick Co., Baltimore.....	302
Oakhill Gas Retort and Fire Brick Co., St. Louis, Mo.....	302

SCRUBBERS AND CONDENSERS.

G. Shepard Page, New York City.....	260
R. D. Wood & Co., Phila., Pa.....	306

REGENERATIVE FURNACES.

Bartlett, Hayward & Co., Baltimore, Md.....	305
Fred. Bredel, New York City	303
Chicago Retort and Firebrick Co., Chicago, Ills.....	302
Wm. Henry White, N. Y. City.....	307
J. H. Gautier & Co., Jersey City, N. J.....	303

GAS GOVERNORS.

Connelly & Co., New York City.....	299
Fred. Bredel, N. Y. City.....	303
Friedrich Lux, London, England.....	291

SELF-SEALING MOUTHPIECE DOORS.

Smith & Sayre Mfg. Co., New York City.....	306
--	-----

TAR AND CARBONIC ACID EXTRACTOR.

Geo. Shepard Page, N. Y. City.....	296
------------------------------------	-----

CEMENTS.

C. L. Gerould & Co., Brooklyn, N. Y.....	302
--	-----

GAS ENRICHERS.

Standard Oil Co., Cleveland, Ohio	308
---	-----

GAS METERS.

John J. Griffin & Co., Phila., Pa.....	310
American Meter Co., New York and Philadelphia.....	311
The Goodwin Gas Stove and Meter Co., Philadelphia, Pa.....	311
Helme & McLhenny, Phila., Pa.....	311
D. McDonald & Co. Albany, N. Y.....	311
Nathaniel Tufts, Boston, Mass.....	310
Maryland Meter and Manufacturing Co., Baltimore, Md	310
Bell & Jones, Philadelphia, Pa.....	310

EXHAUSTERS.

The P. H. & F. M. Roots Co., Connersville, Ind.....	294
Smith & Sayre Manufacturing Co., New York City.....	306
Wilbraham Bros., Philadelphia, Pa.....	299
Connelly & Co., New York City.....	299

GAS COALS.

Penn Gas Coal Co., Phila., Pa	309
Perkins & Co., New York City	308
Newburgh Orrel Coal Co., Baltimore Md.....	309
Despard Coal Co., Baltimore, Md.....	309
Chesapeake and Ohio R. R. Coal Agency, N. Y. City.....	309
Westmoreland Coal Company, Phila., Pa.....	309
J. & W. Wood, New York City.....	308

CANNEL COALS.

Perkins & Co., New York City.....	308
J. & W. Wood, New York City.....	308

VALVES.

Ludlow Valve Manufacturing Co., Troy, N. Y. 300
 John McLean, New York City. 300
 Chapman Valve Manufacturing Co., Boston, Mass. 300
 R. D. Wood & Co., Phila., Pa. 306
 The P. H. & F. M. Roots Co., Connersville, Ind. 294

GAS ENGINES.

Schleicher, Schumm & Co., Phila., Pa. 276
 Clerk Gas Engine Co., Phila., Pa. 300
 Van Duzen Gas Engine Co., Cincinnati, Ohio. 300

ENGINES AND BOILERS.

Jarvis Engineering Co., Boston, Mass. 299
 Balf Engine Co., Erie, Pa. 292
 Westinghouse Machine Co., Pittsburgh, Pa. 303

GAS LAMPS.

G. Shepard Page, New York City. 300
 Weisbach Incandescent Gas Light Co., Phila., Pa. 293
 The Siemens-Lungren Company, Philadelphia, Pa. 293

PURIFIER SCREENS.

John Cabot, New York City. 300
 Bartlett, Hayward & Co., Baltimore, Md. 300

GAS STOVES.

American Meter Co., New York and Philadelphia. 301
 The Goodwin Gas Stove and Meter Co., Phila. Pa. 312
 George M. Clark & Company, Chicago, Ills. 293
 D. McDonald & Co., Albany, N. Y. 311
 Maryland Meter and Manufacturing Co., Baltimore, Md. 310
 Bell & Jones, Philadelphia, Pa. 310

STREET LAMPS.

J. G. Miner, Morrisania, New York City. 256
 Bartlett Street Lamp Man'g Co., New York City. 291

BURNERS.

C. A. Gefroerer, Phila., Pa. 303

STEAM BLOWER FOR BURNING BREESE.

H. E. Parson, New York City. 264

PURIFYING MATERIAL.

Connelly & Co., New York City. 299
 Friedrich Lux, London, England. 291
 Edgewater Lime Works, Edgewater, N. J. 29

COKE CRUSHER.

C. M. Keller, Columbus, Ind. 369

ELECTRICAL APPARATUS.

Win. Henry White, N. Y. City. 307

SOLVENTS.

Maas & Waldstein, New York City. 299

BOOKS, ETC.

Gerould's System Gas Bookkeeping. 291
 1889. Directory. 1889. 302
 King's Treatise. 304
 Scientific Books. 274
 Management of Small Gas Works. 300
 Gas vs. Electricity. 292
 Practical Electric Lighting. 299
 Electric Light Primer. 299
 American Gas Engineer and Superintendents' Handbook. 309
 Digest of Gas Law. 292
 Fuel and its Applications. 291

WANTED,

AN EXPERIENCED

Gas Engineer.

Apply at 111 Broadway,

769-1

Basement, Room D, City

WANTED,

A young man to act as

Meter Taker and to Make Himself Useful

in a small Gas Works. Must understand gasfitting and be strictly temperate. Address, with references,

768-2

"G.," care this Journal.

POSITION WANTED

As Manager of a Gas Works

Making from 5 to 10 million cubic feet per annum. Six years' experience. Address

767-4

"J. M. M.,"

Care this Journal.

POSITION WANTED.

A Mechanical Engineer,

Experienced in Gas Manufacture, wishes a position as Superintendent of a Gas Works. Best of references given and asked. Salary, \$1,200.

"MECHANICAL ENGINEER," care this Journal, 765-1f or Box 972, West Bay City, Mich

Position Wanted

As Superintendent or Assistant of a Gas Works,

By a man who can give the best of references. Thoroughly understands the manufacture and distribution of gas and the construction of works. Address

765-5

"M.," care this Journal.

FOR SALE.

We offer the following gas apparatus for sale, delivered f.o.b. cars Fort Worth, Texas:

Two Benches of 3's, with cast iron Hydraulic Main, Dip and Ascension Pipes, and Mouthpieces (14 by 23 in.).

One Bench of 6's, with cast iron Hydraulic Main, Dip and Ascension Pipes, and Mouthpieces (12 by 20 in.).

Two Benches of 3's, with cast iron Hydraulic Main, Dip and Ascension Pipes, and Mouthpieces (14 by 21 in.).

Four Purifiers, 6 ft by 6 ft., with 6-in. Connections and Center Seal. **Steam Jet Exhauster.** **One Set Pipe Condensers** (6-in.). **One Upright Scrubber**, 11 ft. high by 36 in. diam., with Bye-Pass. **One Station Meter**, daily capacity 100,000 cu. ft. **One Upright Boiler**, 20 horse power.

All of above apparatus in first-class condition and are so guaranteed. For further particulars address

FORT WORTH LT. AND POWER CO.,

767-4

Fort Worth, Texas.

GAS WORKS FOR SALE.

A CONTROLLING INTEREST IN SEVERAL

Interior California Coal Gas Plants,

now paying handsomely, are offered on very reasonable terms. This is an exceptionally good opportunity for practical gas men of limited means, wishing to remove to a mild and healthful climate, to acquire an established and paying business. Particulars given and full investigation solicited.

SECRETARY, 123 Beale Street,

760-3 mos.

San Francisco, Cal.

FOR SALE.

A Complete Water Gas Plant.

60,000 Cu. Ft. Daily Capacity.

Fully equipped; all the latest improvements; includes Generator, Purifiers, and Holder. Can be removed to any part of the country, and set up at small cost. For further information apply to BRADFORD GAS LT. & HEATING CO., Dunkirk, N. Y.

FOR SALE,

One Hydraulic Main (five sections), wrought iron, 22 by 24, with Bye-Pass on Dip-Pipes.

25 Valves, Stand-Pipes, 7-inch Mouthpieces and Lids, all complete, ready for use, to fit up five benches of 5's.

This apparatus is all in first-class condition.

Price, \$800, f.o.b. cars or boat, Poughkeepsie, N. Y.

Inquiries may be sent to this Office.

FRIEDRICH LUX,

Ludwigshafen am Rhein and London.

Lux Mass GAS GOVERNORS, Gas Balance.

6 PER CENT.

First Mortgage Bonds

ON GAS WORKS

SITUATED IN GROWING WESTERN TOWNS.

Principal and Interest Guaranteed.

INTEREST SEMI-ANNUALLY.

For sale by the undersigned, who will furnish all necessary information regarding them.

JOS. R. THOMAS, 42 Pine St., N. Y. City.

Fuel and Its Applications.

By E. J. MILLS, D.Sc. F.R.S., and F. J. ROWAN, C.E., assisted by others, including Mr. F. P. Dewey, of the Smithsonian Inst., Wash., D. C.

7 PLATES, AND 607 OTHER ILLUSTRATIONS. ROYAL OCTAVO, PAGES xx, 802. HANDSOME CLOTH, \$7.50.

A. M. CALLENDER & CO., 42 Pine St., N. Y.

GEROULD'S

System Gas Bookkeeping.

Approved and adopted by many of the prominent Gas Engineers of the Country.

Sample Sheets and Price-List furnished free on application to

L. P. GEROULD, - - Mendota Ill.

EDGEWATER LIME WORKS

Chas. F. McKenna, Proprietor.

SHELL LIME.

Lime by the Cargo for Gas Purification.

EDGEWATER, BERGEN CO., N. J.

Write for Testimonials and Prices.

Bartlett Street Lamp Mfg. Co.

MANUFACTURERS OF

Globe Lamps,

FOR

Streets, Parks, Public Buildings, Railroad Stations, etc.

LAMP POSTS

A Specialty.

Office and Salesroom,

40 & 42 COLLEGE PLACE, - - N. Y. CITY.

Gas Companies and others intending to erect Lamps and Posts will do well to communicate with us.

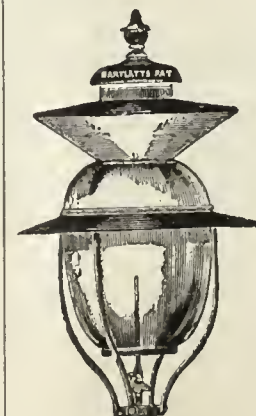

F. D. HARMON, PRES.

CHAS. C. ALLEN, SEC. AND TREAS.

P. W. MACKENZIE, CHIEF ENGR. & SUPT.

THE FUEL GAS AND LIGHT IMPROVEMENT CO.

OF AMERICA.

Owners of the RECENT Mackenzie Patents,
For the United States, England, Russia, France, Germany, Austria, and Canada,
No. 32 Park Place, New York City.

This SYSTEM is an ABSOLUTELY NEW DEPARTURE IN THE MANUFACTURE OF FUEL AND ILLUMINATING GAS. The COST OF GAS IN THE HOLDER by our System is at least THIRTY PER CENT. LESS than that made by any other process of the day.

The Gas is manufactured WHOLLY from LIQUID HYDROCARBONS, such as Lima, Penn, Crude, and Fuel Oils, Naphtha, etc. Neither PERISHABLE PIPES or other RETORTS, NOR THEIR EQUIVALENTS, are used.

Neither COAL, COKE, nor any other HARD CARBONS enter into the manufacture or composition of the Gas, thereby requiring LESS LABOR THAN ANY OTHER METHOD.

The Gas contains neither SULPHUR nor other impurities, nor is there any resultant LAMPBLACK OR TAR RESIDUUM.

The Gas requires NO PURIFICATION whatever.

The FUEL GAS COSTS VERY MUCH LESS than PURE UNCARBURETED WATER GAS, and contains DOUBLE THE HEAT UNITS.

The APPARATUS is extremely SIMPLE, SUBSTANTIAL, and DURABLE, and consists of a Single Body with a capacity of ONE THOUSAND to ONE HUNDRED THOUSAND cubic feet per hour.

Works may be constructed to run by the CONTINUOUS or ALTERNATING method. If run continuously, the limited amount of Nitrogen present is neutralized by Carbon.

The Gas can be made of a HIGH GRADE for illuminating purposes, of a MEDIUM QUALITY for distribution for domestic purposes, and of a LOW GRADE for manufacturing uses.

Wherever Liquid Hydrocarbons can be had the MACKENZIE PROCESS WILL COMPETE IN PRICE AND SUPPLY ALL THE ADVANTAGES incidental to the use of NATURAL GAS.

This Company desires contracts for the construction of Plants, parts of Plants, Apparatus, Buildings, Holders, and Street Mains, for either of the above purposes, and will Lease or Purchase Works upon satisfactory terms.

Information will be promptly given regarding material required for production of Gas, actual cost of product, cost of works, etc.

GASHOLDER PAINT. GAS vs. ELECTRIC LIGHT.

Use Only

THE GOVERNMENT WATERPROOF PAINT.

Proof against Ammonia, and Absolutely Waterproof. Send for Prices and Particulars.

THE GOVERNMENT WATERPROOF PAINT CO., 122 Milk Street, Boston, Mass.

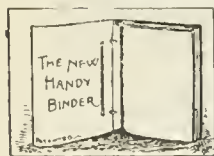

THE NEW HANDY BINDER.

This article may be described as elegant in appearance, strong, durable, and possessing many special qualities of its own. It allows the opening of the pages perfectly flat, whether one or several numbers are in the binder. Any number can be taken out and replaced without disturbing the others. The papers are not mutilated for subsequent binding in permanent form. The binder is supplied with gilt side title, and is an ornament to any desk or reading table. The JOURNAL, filed in the Handy Binder, becomes a volume of great value, always convenient for instant reference. Handy Binder, Postage paid, \$1.00.

A. M. CALLENDER & CO., 42 Pine St., N. Y.

GREENOUGH'S "DIGEST OF GAS LAW."

Price, \$5.00.

This is a valuable and important work, a copy of which should be in the possession of every gas company in the country, whether large or small. As a book of reference it will be found invaluable. It is the only work of the kind which has ever been published in this country, and is most complete. Handsomely bound. Orders may be sent to

A. M. CALLENDER & CO.,
42 Pine Street, N. Y.

BALL AUTOMATIC
CUT-OFF ENGINE
MADE ONLY
BY
THE BALL ENGINE CO
ERIE PA.

Simpkin & Hillyer

RICHMOND, VA.

MANUFACTURERS OF

Gas Works Apparatus

BENCH CASTINGS, CONDENSERS,
Scrubbers, Purifiers, Dry Center Seals,
FOUR-WAY VALVES, GAS VALVES,
SULPHATE OF AMMONIA APPARATUS,
TANKS, ENGINES, BOILERS,
PUMPS, ETC., ETC.

Plans, Specifications and Estimates furnished for new works, or alteration of old works. Correspondence solicited. Works, Newport News, Va.

We would invite attention to the able and exhaustive argument of General A. Hickenlooper, President of the Cincinnati Gas Light and Coke Company, contained in a handsome pamphlet of 96 pages, entitled

"EDISON'S INCANDESCENT ELECTRIC LIGHTS FOR STREET ILLUMINATION. REPORT OF AN ARGUMENT DELIVERED BY A. HICKENLOOPER BEFORE THE COMMITTEE ON LIGHT, MUNICIPAL COUNCIL, CITY OF CINCINNATI, JULY 22, 1886."

This is a subject of special interest to all Gas Light Companies.

Prices.

25 copies.....	\$7.50	100 copies.....	\$22.50
50 copies.....	12.50	250 copies.....	50.00

A sample copy will be sent by mail on receipt of 50 cts.
A. M. CALLENDER, & CO., 42 PINE ST., N. Y. CITY

PATENTS.

FRANKLIN H. HOUGH
Solicitor of American & Foreign Patents.
925 F. ST., WASHINGTON, D. C.

(NEAR U. S. PATENT OFFICE.)

Personal attention given to the preparation and prosecution of applications for Letters Patent. All business before the U. S. Patent Office attended to for moderate fees. **No Agency in the United States possesses superior facilities for obtaining Patents,** or for ascertaining the patentability of inventions. Copies of patents furnished for 25 cents each. Correspondence solicited.

The Gordon Portico Lamp.

A successful Competitor of the Arc Electric Light for lighting Store Fronts, Show Windows, Depots, Railway Sheds, etc., etc.

The Gordon Street Lamp.

A Successful Competitor of the Arc Electric Light for lighting Streets, etc., etc.

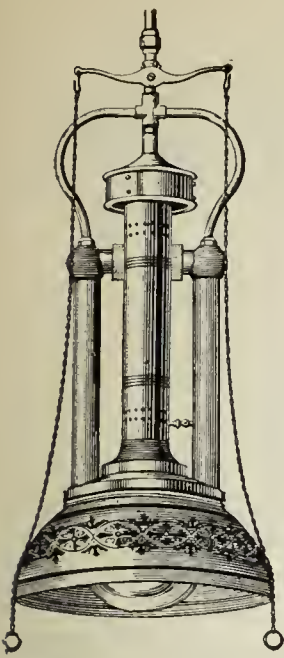

Gordon Portico Lamp.

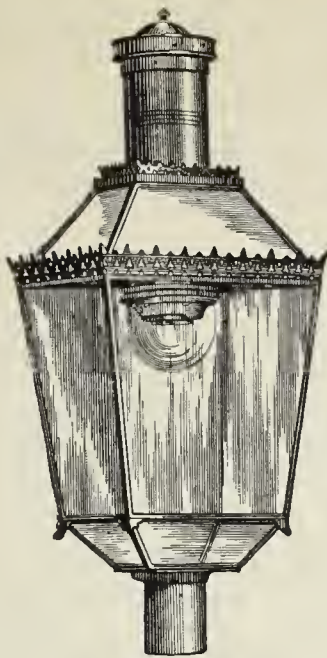

Gordon Street Lamp.

The Lungren Lamp.

A Successful Competitor of the Incandescent Electric Light for Interiors, etc. Is especially applicable for the lighting of Offices, Stores, Factories, Mills, Show Windows, Libraries, and all situations where an increased illumination is desired.

More than 25,000 Lungren Lamps are now in use. Testimonials, references, or any desired information will be cheerfully given.

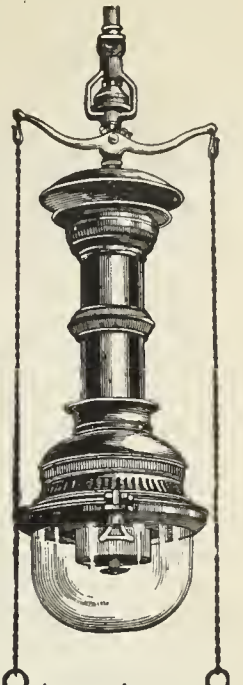

Lungren Lamp.

THE SIEMENS-LUNGREN CO., N.E. Cor. 21st St. & Washington Av., PHILADELPHIA.

WELSBACH SYSTEM OF Incandescent Gas Lighting.

OFFICE, DREXEL BUILDING, PHILA., PA.

At the Fall Session of the Board of Supervisors of Winnebago County, held at the County Court House, Oshkosh, Wis., Nov. 26, 1889, the report submitted by Mr. C. W. Cook, Chairman of the Committee on Public Buildings, recommending the use of the Welsbach Incandescent Gas Burner in the Buildings under their charge, was unanimously adopted, because of the extreme economy in the consumption of Gas and the superior character of the light obtained.

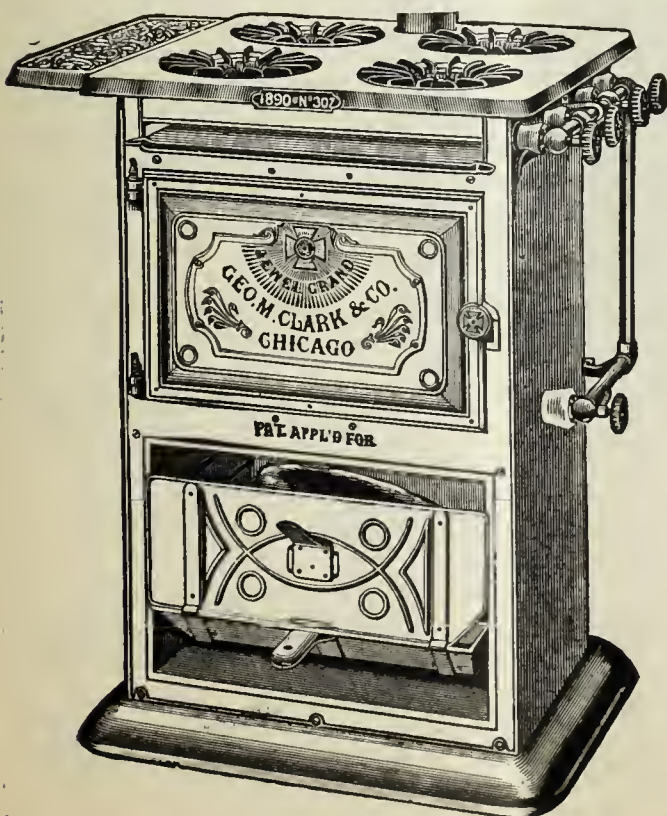

JEWEL GAS STOVES

MANUFACTURED BY

GEORGE M. CLARK & COMPANY,

Nos. 157 & 159 Superior Street, - - - Chicago, Ill.

EVERY CONCEIVABLE SIZE AND STYLE,

Ranging in Prices from \$1.50 to \$30.00.

WE USE NO GAS COCKS.

All Flames are Regulated by a Direct Needle Valve.

The JEWEL

IS THE

Only Well-Made Gas Stove on the Market.



Write for our 1890 Catalogue and see for yourself.

ROOTS' GAS AND BYE-PASS VALVES.

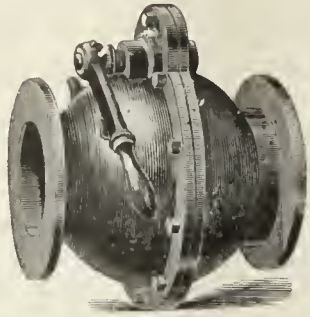

GAS VALVE

Quick Acting,
Simple,
Efficient, Durable.

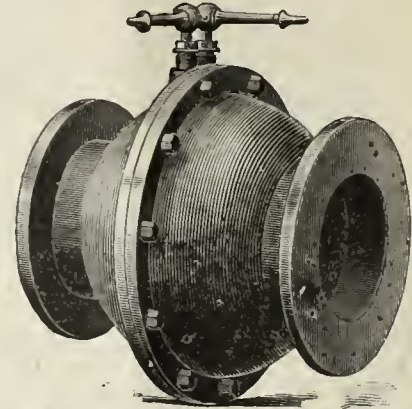

BYE-PASS VALVE.

Automatic Action,
Reliable,
Simple, Durable.

Thousands now in use and giving perfect satisfaction. Write for Catalogue and Prices.

ROOTS' NEW GAS EXHAUSTER.

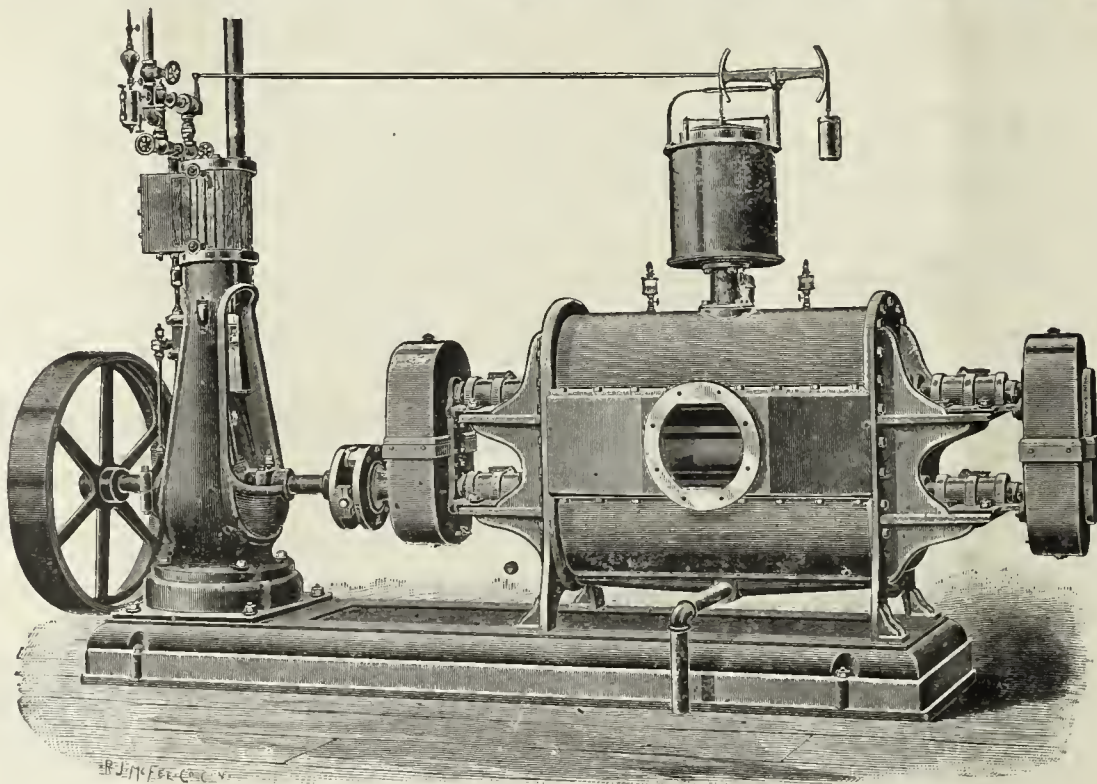

UNSURPASSED FOR

Neatness of Design, Durability, Simplicity, Efficiency, and Economy of Power.

THE ONLY EXHAUSTER MADE WHERE

The Parts Needing Attention are External, and Easily Accessible.

Send for Descriptive Catalogue and Price List.

THE P. H. & F. M. ROOTS CO., Patentees and Manufacturers, **CONNERSVILLE, IND.**

S. S. TOWNSEND, Gen. Agt., 22 Cortlandt St., N. Y.

COOKE & CO., Selling Agts., 22 Cortlandt St., N. Y.

THIS SPACE
WILL BE
Occupied Next Month by the
KERR MURRAY MFG. CO.
FORT WAYNE, IND.
**GAS WORKS
APPARATUS
AND
HOLDERS.**

**DAVIS & FARNUM MFG. CO.,
WALTHAM, MASS.**

PRINCIPAL OFFICE AND WORKS, Waltham, Mass.

BOSTON OFFICE, Room 55, Mason Building, 70 Kilby Street.

SINGLE, DOUBLE,
AND
TRIPLE LIFT

Gasholders.

OF ANY CAPACITY.

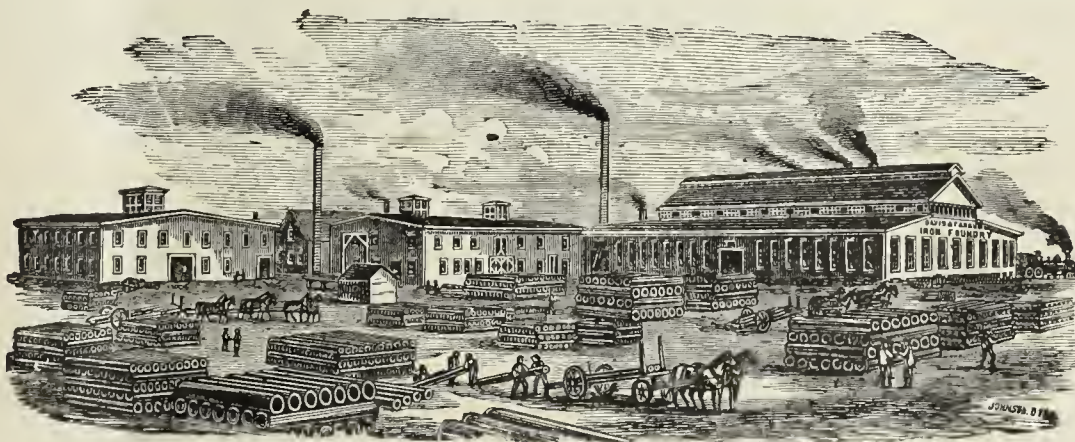

TUBULAR, PIPE,
AND
SINUOUS FRICTION

Condensers.

OF ALL SIZES.

IRON ROOF FRAMES AND FLOORS.

Purifying Boxes, Center Seal or Valve Connections, Bench Work.

Reversible Lime Trays.

SELF-SEALING AND PRESSED STEEL MOUTHPIECE LIDS.

Coke Barrows, Coal Wagons, and all Apparatus Requisite for a Complete Gas Plant.

— ALSO —

Gas and Water Pipe, Flanged Pipe,

Sugar House Work, and Special Castings of all Descriptions.

THE WALKER TAR AND CARBONIC ACID EXTRACTOR.

A very general demand exists, in both large and small Gas Works, for an apparatus that will be absolutely efficient in the removal of the tar which passes the hydraulic main and condenser. Many attempts have been made to accomplish this, but, I believe, without success, until the introduction, five years ago, in England, of the C. & W. Walker Patent Tar and Carbonic Acid Extractor. During these years this apparatus has been adopted by many of the most prominent Engineers, not only in England, but also on the Continent of Europe and in other parts of the world. It is only necessary to give here a partial list in order to convince any intelligent American Gas Engineer that this machine must have succeeded fully in accomplishing the desired results.

The following Engineers have personally given permission to refer to them:

G. C. Trewby, Esq., Engineer-in-Chief of the Gas Light and Coke Co., London. The manufacturing plant at Beckton is built in complete sections of 3,000,000 cubic feet capacity each. A Walker Tar Extractor has been fitted to each one of these sections. This was done after a long and thorough trial on one of its sections. The Tar Extractor has been supplied to other works of the Gas Light and Coke Co., including those of which John Methven, Engineer of the Gas Light and Coke Co. at the Nine Elms Station, is in charge. Also to G. E. Stevenson, Peterborough Gas Works; B. Green, Mitcham and Wimbledon Gas Works; W. H. Smith, Bedford Gas Works; F. Linging, Norwich Gas Works; J. T. Browning, Colchester Gas Works; S. B. Darwin, Portsmouth Gas Works; J. McCrae, Dundee Gas Works; W. J. Wells, Stamford Gas Works; J. M. Darwin, Longton Gas Works; J. Paterson, Warrington Gas Works; and J. Coulter, of the Dundalk Gas Works. All of the foregoing gas works are located in Great Britain.

Mr. Charles A. Gerdenier, Superintendent of the Bridgeport (Conn.) Gas Light Company, writes as follows, under date of Dec. 3, 1887:

"The C. & W. Walker Tar and Carbonic Acid Extractor has been in operation at these works for the past six weeks, and is an unqualified success. It removes every particle of Tar from the gas in once passing through the apparatus, and a large percentage of the Carbonic Acid. I also feel quite sure that it prevents the formation and deposit of Naphthaline, because since I started the Washer I have had no stoppages from this cause. These works have been seriously troubled with Tar for many years, and I have used several kinds of apparatus and every expedient which has come to my attention for dealing with the difficulty, but without success. The Walker apparatus occupies comparatively small space, is less expensive than other systems, and requires but little attention. I carry 2½-inch seal, and have an automatic tar delivery valve. This Tar Extractor is indispensable to gas makers."

I have taken the Agency for the United States for this apparatus, and am now prepared to make contracts to erect it on the premises of any Gas Company. It would be manufactured in the following sizes:

No. 1,	50,000 to	100,000	cu. ft. per	24 hrs.,	3 ft. square,	5 ft. deep.			
No. 2,	"	"	125,000	"	"	"	4	"	"
No. 3,	"	"	250,000	"	"	"	5	"	"
No. 4,	"	"	500,000	"	"	"	6	"	"
No. 5,	"	"	750,000	"	"	"	7	"	"
No. 6,	"	"	1,000,000	"	"	"	8	"	"
No. 7,	"	"	1,250,000	"	"	"	9	"	"
No. 8,	"	"	1,500,000	"	"	"	10	"	"
No. 9,	"	"	2,000,000	"	"	"	12	"	"
No. 10,	"	"	3,000,000	"	"	"	15	"	"

This Tar Extractor will perform its work with about one-fourth the usual back-pressure heretofore required. It is simple in construction, and can be supplied at a very reasonable price—less than any other ever before introduced. Satisfactory results will be guaranteed in every instance.

GEO. SHEPARD PAGE,

SOLE AGENT FOR THE UNITED STATES,

No. 69 Wall Street, - - - New York.

THE UNITED GAS IMPROVEMENT CO.

DREXEL BUILDING, PHILADELPHIA.

OFFICERS:

WILLIAM W. GIBBS, President.

GEORGE PHILLER, Vice-President.

SAM'L T. BODINE, Gen'l Manager.

RANDAL MORGAN, Gen'l Counsel.

EDWARD C. LEE, Sec'y and Treas.

ALEX. C. HUMPHREYS, Gen'l Supt.

WALTON CLARK, Ass't Gen'l Supt.

H. H. EDGERTON, Chem. and Eng'r.

DIRECTORS:

GEORGE PHILLER,

THOMAS DOLAN

HENRY C. GIBSON,

WM. T. CARTER,

WILLIAM G. WARDEN,

SAM'L T. BODINE.

BUILDERS, LESSEES AND PURCHASERS OF

➤ GAS WORKS. ➤

Orders solicited from Large Cities, Small Towns, Mills, Institutions, from all who want more Light for Less Money.

NATIONAL GAS LIGHT AND FUEL COMPANY,

No. 218 La Salle Street, Chicago.

THE SPRINGER SYSTEM

OF

Fuel and Illuminating Water Gas Works.

REFERENCES.

People's Gas Lt. & Coke Co..Chicago, Ill.
 Illinois Light, Heat & Power
 Co.....Chicago, Ill
 Elgin National Watch Co..Elgin, Ill.
 C. R. I. & P. R. R. Shops..Chicago, Ill.
 Decatur Gas Lt & Coke Co..Decatur, Ill.
 Niles Gas Light Co.....Niles, Mich.
 Newton Illuminating Co...Newton, Kansas.
 Wellington Light & Heat Co..Wellington, Kansas.
 Chippewa Falls Gas Lt. Co..Chippewa Falls, Wis.
 Elkhart Gas Lt & Coke Co..Elkhart, Ind.
 Madison City Gas Light Co.Madison, Wis.
 South Bend Gas Light Co..South Bend, Ind.
 Sheboygan National Gas Co.Sheboygan, Wis.
 Salina Gas Light Co.....Salina, Kansas.
 The Rathbun Co.....Deseronto, Prov.Ont.
 Jefferson City Gas Lt. Co..Jefferson City,Mo.
 Mankato Gas Light Co.....Mankato, Minn.
 Lima Gas Light Co.....Lima, Ohio.

Minneapolis Gas Light and
 Coke Co.....Minneapolis, Minn.
 Bellevue Water and Fuel } Bellevue, Campbell
 Gas Light Co..... } County, Ky.
 Bucyrus Gas Lt. & Fuel Co.Bucyrus, Ohio.
 Morris Gas Co.....Morris, Ill.
 Los Angeles Gas Co.....Los Angeles, Cal.
 San Diego Gas Fuel & Elec-
 tric Lt. Co.....San Diego, Cal.
 Sioux Falls Gas Co.....Sioux Falls, Dak.
 Dakota Gas and Fuel Co..Grand Forks, Dak.
 St. Johns Mutual Gas Co..St. Johns, Mich.
 Stillwater Gas Light Co...Stillwater, Minn.
 St. Paul Gas Light Co....St. Paul, Minn.
 Emporia Electric and Gas
 Light Co.....Emporia, Kas.
 Van Wert Gas Light Co...Van Wert, Ohio.
 Lansing Gas Light Co.....Lansing, Mich.
 San Francisco Gas Lt. Co..San Francisco, Cal.

Shelbyville Gas Light Co..Shelbyville, Ind.
 Great Falls Gas Light Co.. Great Falls, N. H.
 Belleville Gas Co.....Belleville, Ontario
 Rochester Lt. and Fuel Co..Rochester, Minn.
 Northwestern Gas Light and
 Coke Co.....Evanston, Ill.
 Lincoln Gas Light Co....Lincoln, Neb.
 Davenport Gas Light Co...Davenport, Iowa.
 Municipal Gas Co.....Albany, N. Y.
 Alliance Gas Light Co....Alliance, Ohio.
 New Gas Light Co.....Janesville, Wis.
 Chicago Gas Lt. & Coke Co., Chicago, Ill.
 Joliet Gas Co.....Joliet, Ills.
 Superior Light & Fuel Co..Superior, Wis.
 Kewanee Gas Light Co...Kewanee, Ill.
 Aberdeen Light & Fuel Co..Aberdeen, So. Dak.
 Pierre Light and Fuel Co..Pierre, So. Dak.
 *Standard Gas Light Co...New York City.
 *Carlinville Gas Light Co..Carlinville, Ill.

* Building.

GUARANTEED ESTIMATES of Cost of Gas Furnished on Application.

GASHOLDER TANK CONSTRUCTION, ETC.

Gas Companies and others about to erect Gasholders will find it profitable to consult W. C. Whyte, who for over 30 years has made a specialty of

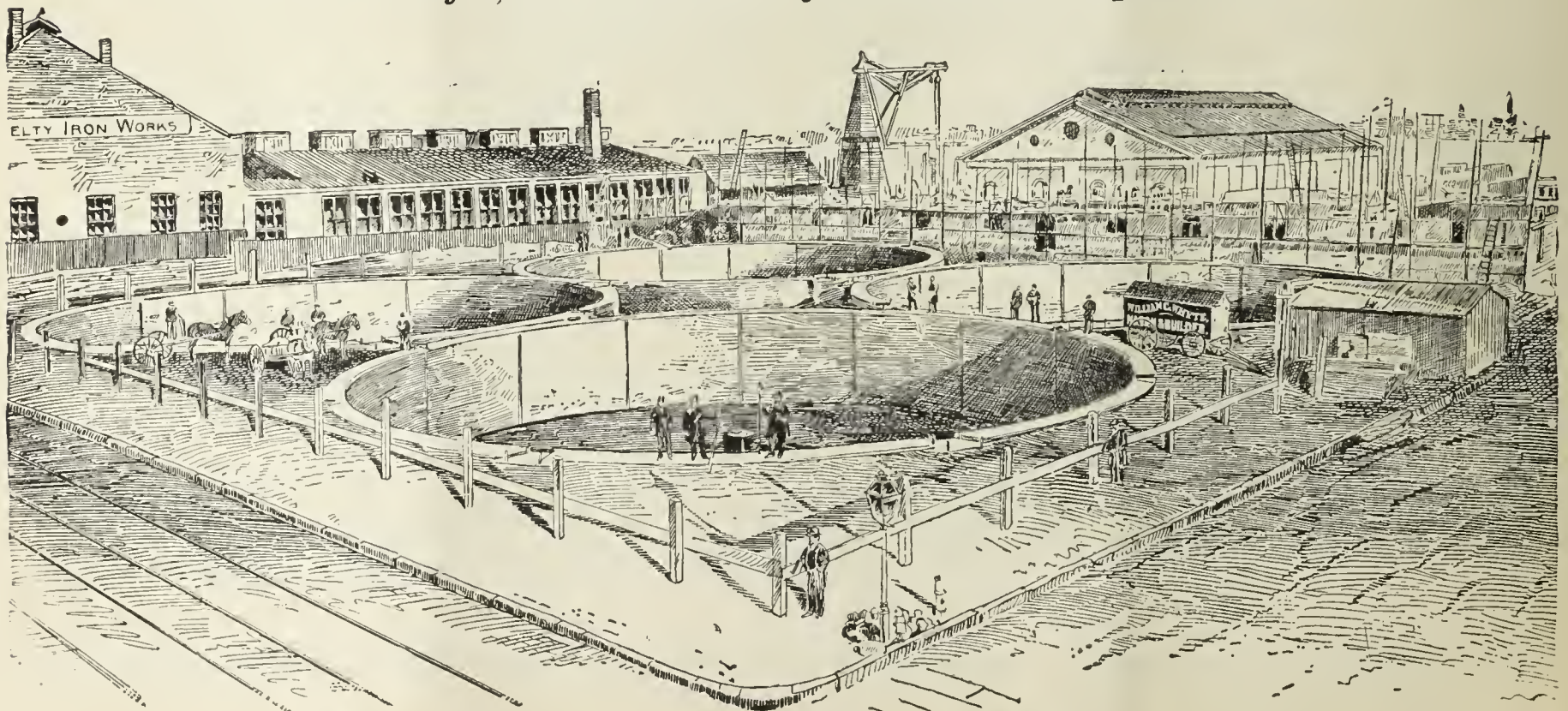

Tank Excavation and Mason Work.

Fifty Tanks now in operation show the sort of work done. Address

W. C. WHYTE, - No. 15 Cortlandt Street, N. Y. City.

CONNELLY & CO.,

SOLE MANUFACTURERS OF THEIR PATENTED SPECIALTIES.

"IRON SPONGE." Saves money, saves labor, and is the most efficient purifying agent ever offered as a substitute for lime. Now used in every State in the Union, and purifying daily over thirty-five million cubic feet. Should be used in every gas works. Its own saving will pay for it many times over.

AUTOMATIC GOVERNOR. Has been on the market but three years, and in that time has been introduced more generally than any invention ever designed for use in gas works. Over two hundred of them now in use. Sensitive; reliable; perfectly automatic; reduces leakage; satisfies consumers, and gives great relief to the Manager. No gas works is complete without one of these machines.

STEAM JET EXHAUSTER. Designed particularly for small works. Combines Exhaust Tube, Steam Governor Gas Compensator, and Bye-Pass Valves in the most compact form possible; occupies but little space; uses very little steam; operated by ordinary workmen; saves formation of carbon in retorts; increases yield 10 to 15 per cent. Specially adapted for mixing air with oil gas. No works too small to use them profitably.

Prices given on all our specialties delivered at any point in the United States. Correspondence solicited.

CONNELLY & CO., No. 111 Broadway, New York City.

WILBRAHAM GAS EXHAUSTER & ENGINE COMBINED.

WILBRAHAM BROS.,
PHILADELPHIA, PA.

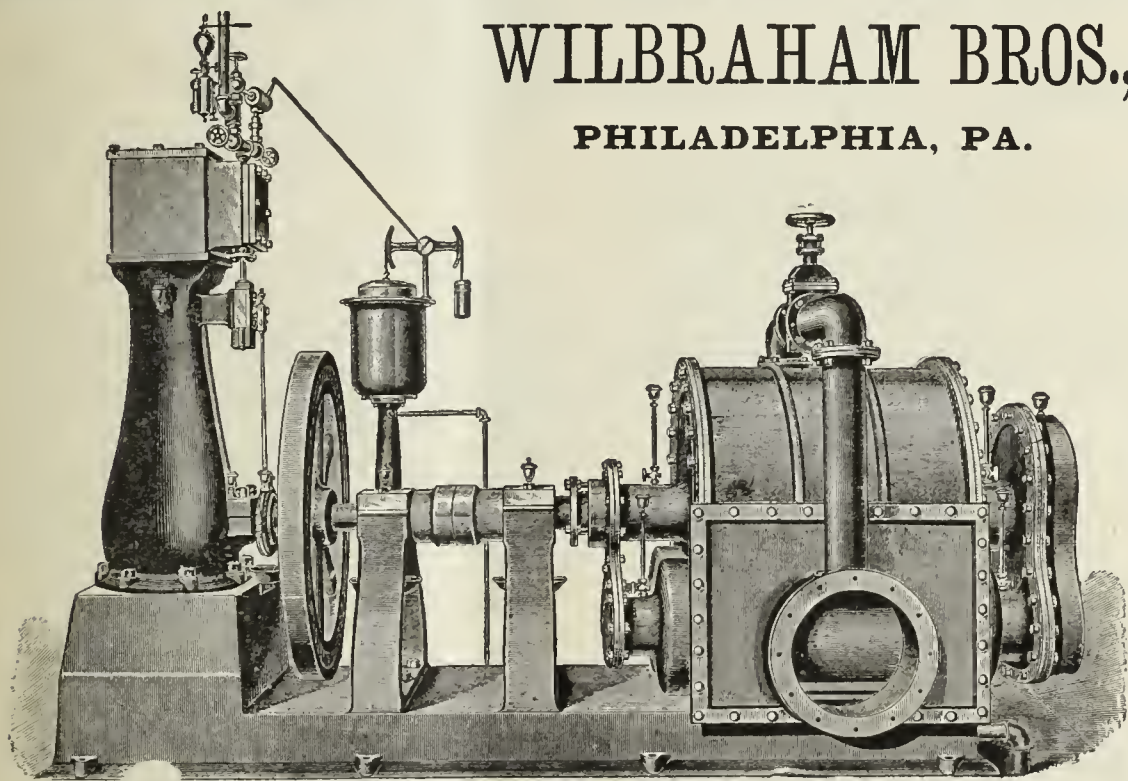

JARVIS ENGINEERING CO.,

61 Oliver St., Boston, Mass.

CONTRACTORS FOR ERECTING

COMPLETE STEAM OUTFITS FOR ELECTRIC LIGHTING STATIONS.

Steel Boilers set with Jarvis Pat. Boiler Setting

To burn **COKE SCREENINGS** for Fuel.

ARMINGTON & SIMS CO. ENGINES,

Belting direct to Dynamos, without using Shafting.

SEND FOR CIRCULARS.

REFERENCES. - Charlestown Gas & Electric Light Co., Charlestown, Mass.; Schenectady Gas & Electric Light Co., Schenectady N. Y.; Brookline Gas Co., Brookline, Mass.

Practical Electric Lighting

By A. BROMLEY HOLMES, A.M.I.C.E.

With 87 Illustrations. Third Edition. Price, \$1.00.

Electric Light Primer.

By CHARLES L. LEVEY.

A simple and comprehensive Digest of all the most important facts connected with the running of the Dynamo and Electric Lights, with Precautions for Safety, etc.

Price, 50 cents.

A. M. CALLENDER & CO., 42 Pine St., N. Y.

(Patented.)

IMPORTANT!

(Patented)

NEW SOLVENT FOR GAS PIPE DEPOSITS.

Economical and Effective.

MAAS & WALDSTEIN, 44 Trinity Place and 81 Greenwich St., N. Y.

Gasholder Tanks & Gas Works Masonry Complete.

PLANS PREPARED AND ESTIMATES FURNISHED AT SHORT NOTICE.

J. P. WHITTIER, - - 499 Wythe Av., Brooklyn, N. Y.



CHAPMAN VALVE MANUFACTURING CO.,

MANUFACTURERS OF

Valves and Gates for Gas, Ammonia, Water, Etc.

Also, Gate Fire Hydrants With and Without Independent Nozzle Valve. All Work Guaranteed.

WORKS & GEN'L OFFICE:
Indian Orchard, Mass.

TREASURER'S OFFICE:
72 Kilby & 112 Milk Sts, Boston, Mass.

LUDLOW VALVE MFG. CO.

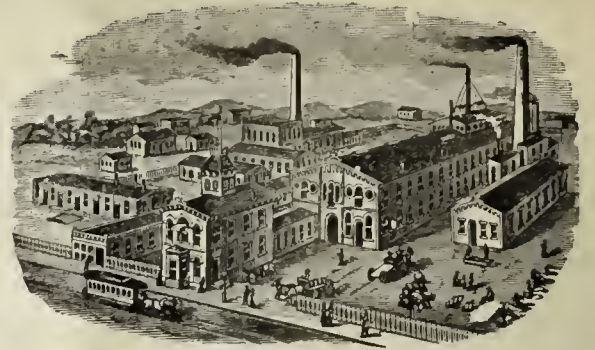

OFFICE AND WORKS,

938 to 954 River Street and 67 to 83 Vail Av.,
TROY, N. Y.

GEO. SHEPARD PAGE,

No. 69 Wall Street, N. Y. City.

REPRESENTING

THE BOWER GAS LAMP.

C. & W. Walker's Carbonic Acid & Tar Extracting Washer

B. DONKIN & CO.'S PAT. IMP. GAS VALVE.

Young & Beilby's Patents. Henry Aitkin's Patents.

R. P. SPICE, London, Eng. HENRY SIMON, Manchester, Eng.

MILLS' REVERSIBLE LIME TRAY,

AND

WOODWORK

Of Every Description

NEEDED BY GAS WORKS.

SEND FOR CIRCULAR AND PRICE LIST TO

BARTLETT, HAYWARD & CO.,

Pratt and Scott Streets, Baltimore, Md.

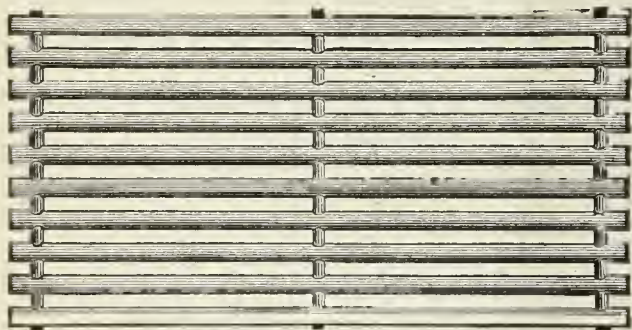

VAN DUZEN GAS & GASOLINE ENGINE

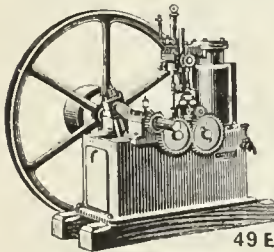

OPERATED with COAL and OTHER MANUFACTURED GASES AND GASOLINE.

RELIABLE AND ECONOMICAL.

Fully Warranted
VAN DUZEN Gas & Gasoline Engine Co.
49 E. 2d St., Cincinnati, O.

A. MacKinnon Machine Co., Agts., 22 Warren St., N.Y.

The Management of Small Gas Works.

BY C. J. R. HUMPHREYS.

Price, \$1.

Orders to be sent to A. M. CALLENDER & CO.,

42 PINE STREET, NEW YORK.

Hydraulic Main Dip Regulators, also Check Valves, Foot Valves, Yard-wash and Fire Hydrants. Send for Circulars.

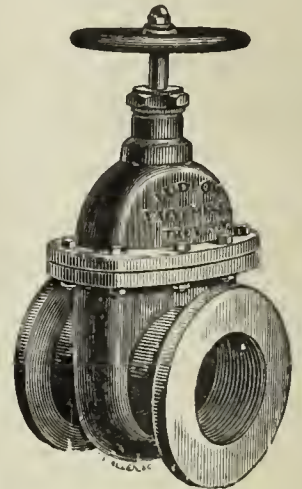

Valves.—Double and Single Gate, 1/2 in. to 48 in., outside and inside Screws. Indicator, etc., for Gas, Water, Steam, and Oil. Send for Circulars.

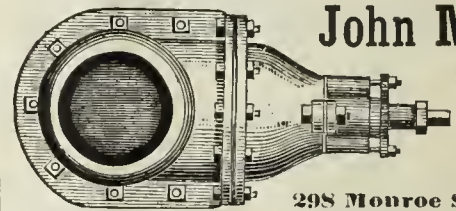

John McLean

Man'facturer

GAS VALVES.

298 Monroe Street, N. Y.

CHURCH'S TRAYS A SPECIALTY.

REVERSIBLE—STRONGEST—MOST DURABLE—MOST EASILY REPAIRED.

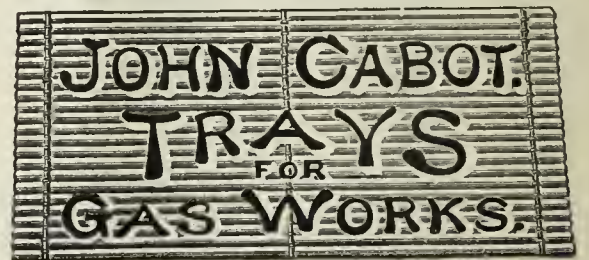

306-310 ELEVENTH AVENUE, NEW YORK.

WE ALSO MAKE THE CHEAPEST AND STRONGEST REVERSIBLE BOLTED TRAYS IN THE MARKET.

THE CLERK GAS ENGINE CO.,
Main Office, 1012, 1014, 1016, 1018 Filbert St., Philadelphia, Pa.

WM. W. GOODWIN, Prest.

E. STEIN, Sec.

S. LEWIS JONES, Asst. Sec.

A. J. DOTY, Supt.

The utility and convenience of the Gas Engine being no longer an open question, it only remains now for intending purchasers to select the BEST. We claim for the CLERK GAS ENGINE that it is equal to any other manufactured as regards steadiness in running, simplicity, and ease of keeping in repair, and that it gives the greatest amount of power for the least money (both in first cost and expense of running) of any engine made. In support of this claim we refer to the test of the Gas Engines made under the direction of the American Institute of New York, in December, 1885, and heretofore published in these columns. These engines are especially adapted for continuous running under heavy loads, and we can refer to Engines which have run 22 hours a day for months at a time

Made in Sizes of 5 10 15 20, and 25 Horse Power. All Engines Guaranteed for One Year.

GAS STOVES.

GAS METERS.

GAS STOVES.

THE AMERICAN METER CO.,

MANUFACTURERS OF

GAS METERS, Station Meters,

METER PROVERS, PHOTOMETERS,
PRESSURE GAUGES OF ALL KINDS,

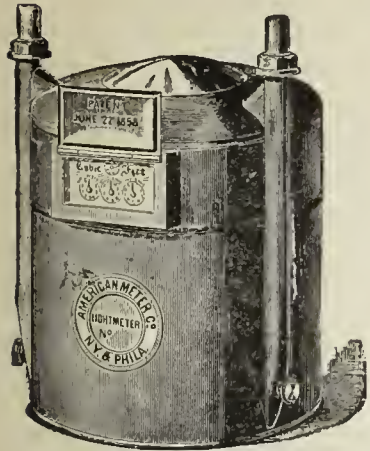

Standard 3 Diaphragm Dry Meter

AND



Standard 2 Diaphragm Dry Meter.

Apparatus for Testing the Quantity and Quality of Gases.

GAS STOVES FOR HEATING AND COOKING

Sole Agents in the United States for

Verity's Patent Gas Fires.

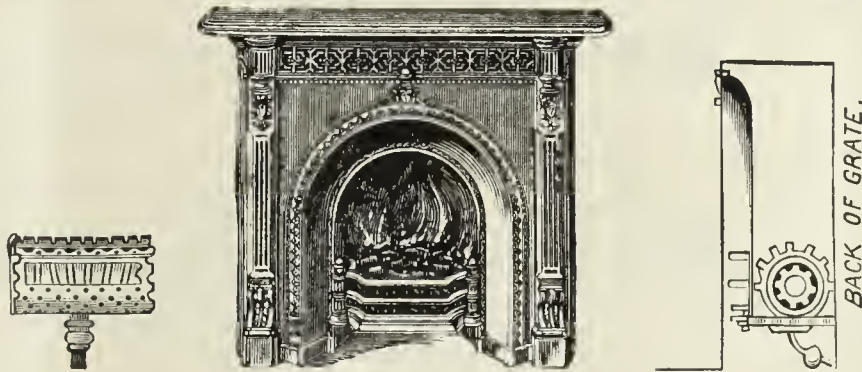

Circulars and Price Lists on Application.

MANUFACTORIES,

508 to 514 West Twenty-second St., N. Y.

Arch and Twenty-second St., Phila.

Nos. 244 & 246 North Wells Street, Chicago, Ill.

AGENCIES,

No. 177 Elm Street, Cincinnati, Ohio.

No. 222 Sutter Street, San Francisco, Cal.

No. 810 North Second Street, St. Louis, Mo.

GAS STOVE SHOW ROOMS, No 242 Sixth Avenue, New York City.

RETORTS AND FIRE BRICK.

J. H. CAUTIER & CO.,
CORNER OF
GREENE AND ESSEX STREETS,
JERSEY CITY, N. J.

MANUFACTURERS OF
**Clay Gas Retorts,
Gas House Tiles,
Fire Bricks, Etc. Etc.**
Ground Clay, Fire Brick and
Fire Sand in Barrels,

J. H. GAUTIER. C. E. GREGORY. C. E. GAUTIER.

BROOKLYN
Clay Retort & Fire Brick Works,
(EDWARD D. WHITE & CO.)
Manufacturers of Clay Retorts, Fire Brick,
Gas House and other Tile.
VAN DYKE, ELIZABETH, RICHARDS & PARTITION STS.
Office, 88 Van Dyke St., Brooklyn, N. Y.

RETORTS AND FIRE BRICK.

LACLEDE FIRE BRICK MFG. CO.,
MANUFACTURERS OF
Fire Brick, Gas Retorts,

AND
ST. LOUIS STANDARD SEWER PIPE.
Blast Furnace and Cupola Linings, every description of Fire
Clay Material, Fire Clay Flue Linings, Chimney Tops
Dry Milled and Crude Fire Clays, etc.

OFFICE AND DEPOT
901, 903, and 905 Pine Street,
ST. LOUIS, MO.

ESTABLISHED IN 1845.

B. KREISCHER & SONS,
OFFICE FOOT OF HOUSTON ST., E. R., N. Y.
Gas Retorts,
TILES, FIRE BRICK.
AND EVERYTHING IN THE FIRE CLAY LINE.

RETORTS AND FIRE BRICK.

MANHATTAN
FIRE BRICK & ENAMELLED CLAY
RETORT WORKS
ADAM WEBER.

**CLAY GAS RETORTS
AND RETORT SETTINGS**
FIRE BRICKS, TILES, ETC.,
Office and Works, 15th Street and Avenue C., N. Y.



Works,
LOCKPORT STATION, PA.

—ESTABLISHED 1864.—

JAMES GARDNER, JR.,

Office, Rooms 19 & 20, Lewis Block,
PITTSBURGH, PA. P. O. Box 373.

Successor to WILLIAM GARDNER & SON.

Fire Clay Goods for Gas Works.

H. A. NORTON, No. 4 CENTRAL STREET, BOSTON, MASS.. Agent for the New England States.

GEO. C. HICKS, CHICAGO CHAS. A. REED,
Pres. Sec. & Treas.
Retort and Fire Brick Co.,
MANUFACTURERS OF
Fire Clay Goods of all Kinds,
AND BEST QUALITY ONLY.
Regenerative Furnaces & Water Gas Goods.
45th St., Clark to La Salle, Chicago.

GEROULD'S IMPROVED RETORT CEMENT.
A Cement for patching retorts, putting on mouthpieces, and
making up all bench-work joints. This Cement is mixed ready
or use. Economic and thorough in its work. Fully warranted
o stick. For recommendations and price list address
C. L. GEROULD & CO.,
5 & 7 Skillman St., Brooklyn, N. Y.
Western Agent, H. T. GEROULD, Mendota, Ill.

**Parker-Russell
Mining and Mfg. Co.,**

CITY OFFICE: { Me mod-Jaccard Bldg., Rooms 307 & 308,
{ Broadway and Locust Street, St. Louis, Mo.

PROPRIETORS OF THE
OAKHILL GAS RETORT & FIRE BRICK W'KS

Our immense establishment is now employed almost entirely in
the manufacture of materials for

GAS COMPANIES.

We have studied and perfected three important points. Our re-
torts are made to stand changes of temperature, the strongest
heats of the furnace, and the abrasion of feeding and emptying.

We furnish and build Half-Depth or Full
REGENERATOR FURNACES
of different kinds and most approved styles.

Correspondence solicited.

THOS. SMITH, Prest. AUGUST LAMBLA, Vice-Prest. & Supt.

BALTIMORE
RETORT & FIRE BRICK CO.

MANUFACTORY AT
LOCUST POINT, BALTIMORE, MD.

**Clay Retorts, Blocks & Tiles,
FIRE BRICK, FIRE CLAY,
AND FIRE CEMENT.**

Red and Buff Ornamental Tiles and Chim-
ney Tops. Drain and Sewer Pipe (from
2 to 30 inches). Baker Oven Tiles
12 x 12 x 2 and 10 x 10 x 2.

WALDO BROS., 88 WATER ST., BOSTON, MASS
Sole Agents the New England States.

1889 DIRECTORY 1889

OF THE GAS LIGHT COMPANIES of the UNITED STATES & CANADA.

Price, \$3.00.

A. M. CALLENDER & CO., No. 42 Pine Street, N. Y. City.

HENRY MAURER & SON,
 (ESTABLISHED 1856.)
EXCELSIOR FIRE BRICK & CLAY
RETORT WORKS
 WORKS, Perth Amboy, N. J.
 OFFICE, 418 to 422 East 23d St., N. Y.
Clay Gas Retorts,
BENCH SETTINGS,
 Fire Brick, Tiles, Etc.

FLEMMING'S
Generator-Gas Furnace

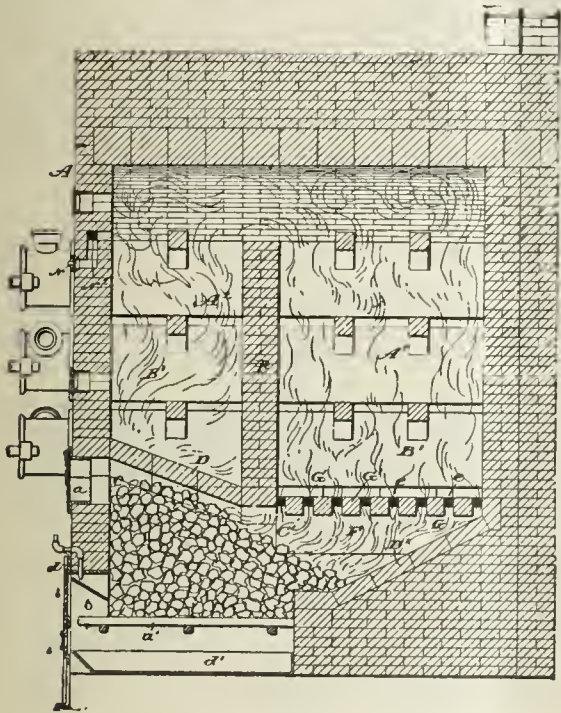

Materials furnished and Benches erected by
J. H. GAUTIER & CO., - Jersey City, N. J.
 Address as above, or D. D. FLEMMING, Jersey City, N. J.

FRED. BREDEL,
 CONTRACTOR FOR THE COMPLETE
Erection and Equipment of Gas Works.
 SOLE PROPRIETOR OF THE
KLOENNE PATENTS
 FOR NORTH AMERICA.

REGENERATIVE FURNACES.
 (900 Retorts are now fired in America by the Kloenne-Bredel System.)

SELF-SEALING MOUTHPIECES.
 (Over 800 Now in Use.)

Standard Condensers. Washer-Scrubbers.

TAR WASHERS FOR WATER GAS PLANTS.
 (In use in the works of the Chicago Gas Lt. Co.)

GASHOLDERS.

Bredel's Automatic Gas Governor.

Refers, by permission, to Mr. Eugene Vanderpool, Newark, N. J.; Mr E. G. Cowdery, Milwaukee, Wis.; and Mr. Theo. Forstall, Chicago, Ills. For further information, address

FRED. BREDEL,
No. 208 East Seventeenth Street, N. Y. City.

Plans and Estimates Furnished for New Works or for the Alteration of Old Works.

HENRY PRATT & CO.,
 BUILDERS OF THE
PRATT & RYAN WATER GAS GENERATORS,
 Arranged to Use Either Crude Oil or Naphtha.
Condensers, Scrubbers, Purifiers, and all Apparatus for Coal or Water Gas.
IRON ROOFS, BOILERS, TANKS, ETC.
 Orders and Correspondence Solicited.

Office and Works,
 869 to 875
 So. Halsted St.
CHICAGO, ILL.

COMPOUND Condensing or Non-Condensing.
 16 SIZES, 5 to 500 H. P.
 Not yet equaled by any form of Engine for
HIGH FUEL DUTY AND SIMPLICITY.

STANDARD 13 Sizes in Stock.
 5 to 250 H. P.
 3000 in use in all parts of the Civilized World.

JUNIOR 6 Sizes in Stock,
 5 to 50 H. P.
 An Automatic Engine cheaper than a Slide Valve.
 WELL BUILT. ECONOMICAL. RELIABLE.
 Over 300 Sold the First Year.

All the above built strictly to Gauge with INTERCHANGEABLE PARTS.
 REPAIRS CARRIED IN STOCK.
 SEND FOR ILLUSTRATED CATALOGUES.

WESTINGHOUSE
ENGINES
 The Westinghouse Machine Co.
PITTSBURGH, PA. U.S.A.

SELLING DEPARTMENT IN THE UNITED STATES.

New York,	17 Cortlandt St.	} Westinghouse, Church, Kerr & Co.
Boston,	Hathaway Building,	
Pittsburgh,	Westinghouse Build'g,	
Chicago,	156, 158 Lake St.	
Philadelphia,	608 Chestnut St. M. R. Muckle, Jr. & Co.	

ST. LOUIS,
 511 NORTH FOURTH ST.,
 Westinghouse, Church, Kerr & Co.

Salt Lake City,	259 S. Main St.	} Utah & Montana Machinery Co.
Butte, Mont.	L. Granite St.	
San Francisco,	21, 23 Fremont Street,	} Parke & Lacy Co.
Portland, Or.	33, 35 N. Front St.	
Charlotte, N. C.	36 College St.	} The D. A. Tompkins Co.
Atlanta, Ga.	45 S. Prior St.	
Dallas, Tex.		} Keating Imp. & Machine Co.
Chattanooga, Tenn.,		

GAS AND WATER PIPES.

GAS AND WATER PIPES.

ENGINEERS.

SAM'L R. SHIPLEY, Pres.
HENRY B. CHEW, Tre

JAS. P. MICHELLON, Sec.
WM. SEXTON, Supt.

GLOUCESTER IRON WORKS,
GLOUCESTER CITY, N. J.



Cast Iron Gas & Water Pipes, Stop Valves, Fire Hydrants, Gasholders. &c.

Office, Rooms 61 and 63 Bullitt Building, 131 S. 4th St., Phila., Pa.

WARREN FOUNDRY AND MACHINE CO.

Established 1856. Works at Phillipsburgh, N. J.

New York Office, 160 Broadway.

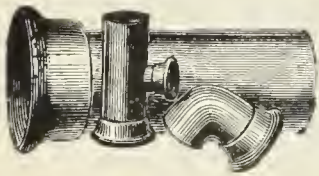

CAST IRON WATER AND GAS PIPE,

FROM TWO TO FORTY-EIGHT INCHES DIAMETER. ALSO, ALL SIZES OF

Flange Pipe for Sugar House and Mine Work. Branches, Bends, Retorts, etc., etc.

DENNIS LONG & COMPANY,

LOUISVILLE, KY.,



Manufacture Exclusively

CAST IRON GAS & WATER PIPE & SPECIAL CASTINGS
OF ALL SIZES.

King's Treatise on Coal Gas.

A standard text-book for the Engineers and Managers of Gas Works, and for all who are concerned or take an interest in the manufacture and distribution of Coal Gas, and in the utilization of the Secondary Products resulting therefrom; treating also of the Gas Engine, and of Gas Cooking and Heating Appliances.

In 3 Vols. Price per Vol., \$10. Sold either by Volume or in Sets.

A M. CALLENDER & CO., 42 Pine St., N. Y.

P. D. WANNER, Chairman. A. H. MELLERT, Mangr. of Wks.
R. B. KINSEY, Secretary. F. A. KNOPP, Treasurer.

MELLERT FOUNDRY & MACHINE CO. Ltd.
and **READING FOUNDRY CO., Ltd.**
Reading, Pa.



Specials—Flange Pipe, Valves and Hydrants
Lamp Posts, Retorts, etc.

General Foundry and Machine Work.

JOHN FOX, Selling Agent, 160 Broadway, N. Y.

THE OHIO PIPE COMPANY,

MANUFACTURERS OF

Cast Iron Gas & Water Pipe,

BRANCH AND SPECIAL CASTINGS.

Gas-House Bench Castings, Hydraulics, Lamp Posts, Flange Pipe
and Specials, Architectural Castings, Building Columns,
Joists, Cellar Grates, Sash Weights, etc.

GENERAL FOUNDERS AND MACHINISTS.

Columbus, Ohio.

M. J. DRUMMOND,



SPECIAL CASTINGS AND LAMP POSTS.
Office, Corbin Building, 192 Broadway, N. Y.

EMAUS PIPE FOUNDRY.

DONALDSON IRON COMPANY. EMAUS, PA.



MANUFACTURERS OF

CAST IRON PIPE AND SPECIAL CASTINGS
FOR WATER AND GAS.

JOS. R. THOMAS,

No. 42 Pine Street, N. Y. City.

CONSULTING AND CONSTRUCTING
Gas Engineer and Contractor.

PLANS, SPECIFICATIONS, AND ESTIMATES
FURNISHED.

Contracts taken for all Appliances
required at a Gas Works,
Either for New Works or Extensions to Old Plants.

WM. MOONEY

(Successor to WM. FARMER)

No. 94 Liberty St., N. Y. City.

GAS ENGINEER AND CONTRACTOR FOR THE ERECTION
OF GAS WORKS, OR APPARATUS OF ANY
CAPACITY.

Plans and Specifications Furnished.

WM. GARDNER,
Gas Engineer,

Lewis Block, Room 20, Pittsburgh, Pa.

Those who intend to make alterations in existing gas plants, or who contemplate the erection of new works, will find it to their interest to open correspondence with the above. Plans made and estimates furnished.

ARTLETT, HAYWARD & CO.

Baltimore, Md.

Triple Double, & Single-Lift
GASHOLDERS.

Iron Holder Tanks.

ROOF FRAMES.

Cirders.

BEAMS.

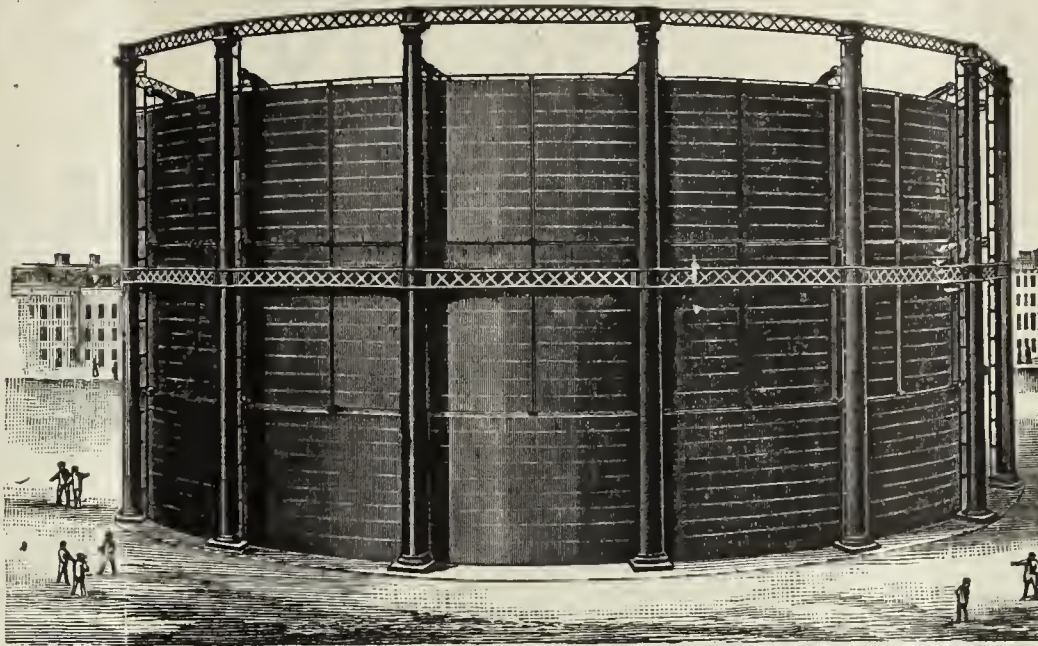

PURIFIERS.

CONDENSERS.

Scrubbers.

BENCH CASTINGS.

OIL STORAGE TANKS.

Boilers.

The Wilkinson Water Gas Process.

THIRTY-CANDLE, NON-CONDENSABLE, FIXED GAS. THE MOST SUCCESSFUL GAS PROCESS IN OPERATION.

Munich Regenerative Furnace, System Drs. Schilling & Bunte.

HAZELTON BOILERS.

Gas Works Designed and Constructed.

Pascal Iron Works. ESTABLISHED 1821. Delaware Iron Works.

MORRIS, TASKER & CO.,

INCORPORATED.

OFFICE, 224 SOUTH THIRD STREET, - - PHILADELPHIA, PA.

CONTRACTORS, BUILDERS, AND MANUFACTURERS OF

Gas, Water & Sugar Works

Bench Castings.

Condensers.

Scrubbers.

Purifiers.

Hyd. Carriages.

Iron Floors,

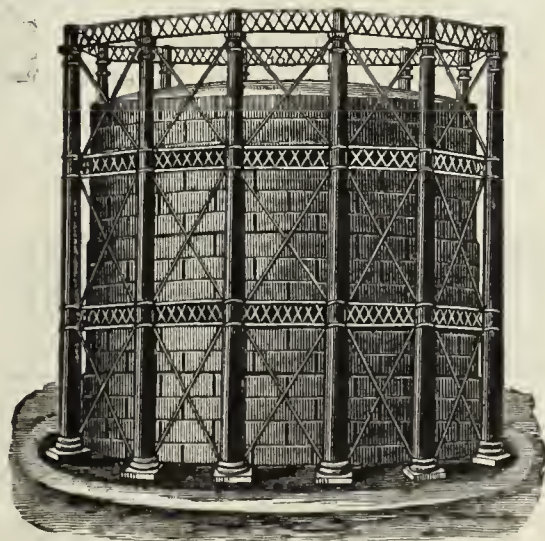

Iron Roofs.

Street Stops,

Valves, etc.

Stand-Pipes.

Water & Oil

Tanks, all Sizes.

Single, Double, and Triple-Lift Gas Holders.

SELF-SEALING RETORT LIDS. STAMPED STEEL RETORT LIDS.

Locomotive Water Columns, Filters, etc. Boiler Tubes, Wrought Iron Pipe & Fittings

Plans, Specifications and Estimates for all kinds of Machinery furnished on application.

Foundries & Works,
MILLVILLE, FLORENCE,
and CAMDEN, N. J.

R. D. WOOD & CO.,

Engineers,
Iron Founders,
and
Machinists.

400 Chestnut St., PHILADELPHIA, PA.

MANUFACTURERS OF

CAST IRON PIPE,

Gas Holders,

SINGLE, DOUBLE, AND TRIPLE LIFTS, WITH
OR WITHOUT WROUGHT IRON
OR STEEL TANKS.

PURIFIERS, CONDENSERS.

Scrubbers.

BENCH WORK.

Iron Floors and Roofs, Plate Girders.

Heavy Loam Castings.

HYDRAULIC WORK.

Lamp Posts, Valves, Etc.

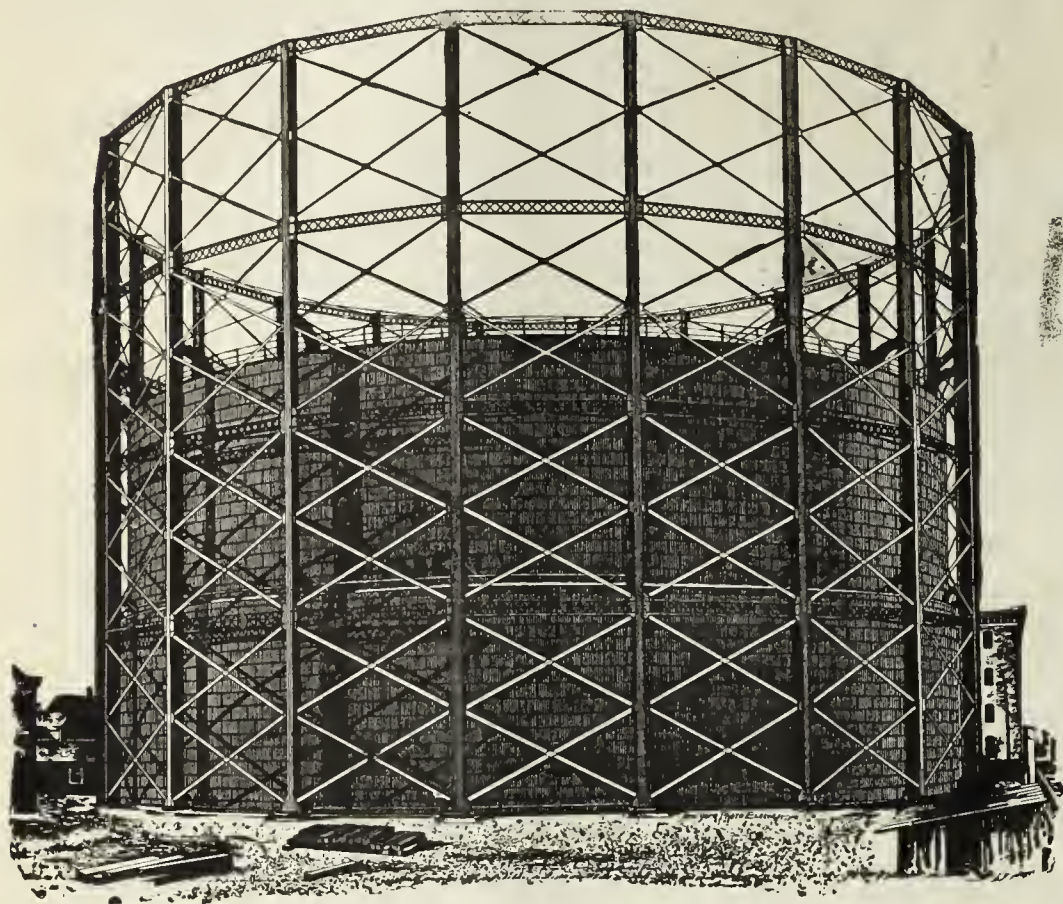

SMITH & SAYRE MFG. COMPANY,

G. G. PORTER, Prest.

245 Broadway, N. Y.

CHAS. W. ISBELL, Sec'y.

Machinery & Apparatus for Gas Works

Drawings, Plans, and Estimates Furnished for the Improvement, Extension, or Alteration of Gas Works, or for the Construction of New Works.

Mackenzie's Patent Rotary and Steam Jet Gas Exhausters, Governors, Compensators, Condensers, Washers, Scrubbers. Isbell's Patent Automatic Street Pressure Governor, Gas and Water Valves, Hydraulic Main Dip Regulator, Bench Castings, etc. Purifying Boxes and "Standard" Bernblers. Isbell's Patent Self-Sealing Retort Doors.

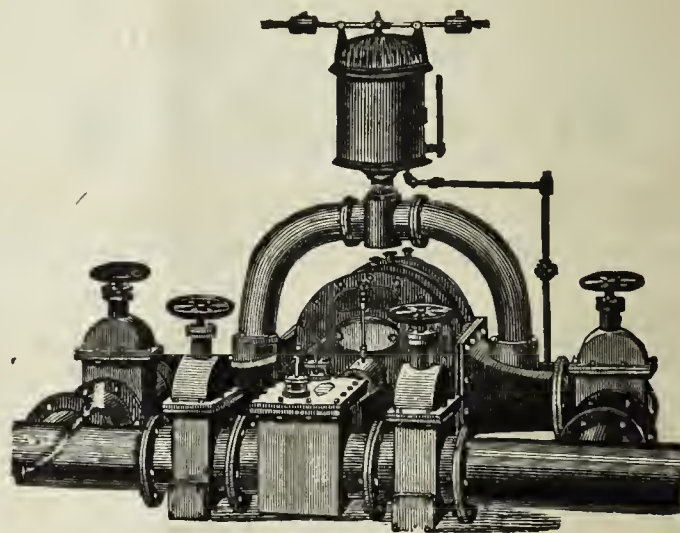

THE BRENNER SELF-SEALING RETORT DOOR.

Simple, Strong, and Durable.

CLOSES ABSOLUTELY TIGHT & IS LOCKED BY A CAM LEVER. ALL NECESSARY ADJUSTMENT FOR WEAR PROVIDED.

BUILT BY

SMITH & SAYRE MFG. CO.,

No. 245 Broadway, - - - New York City.

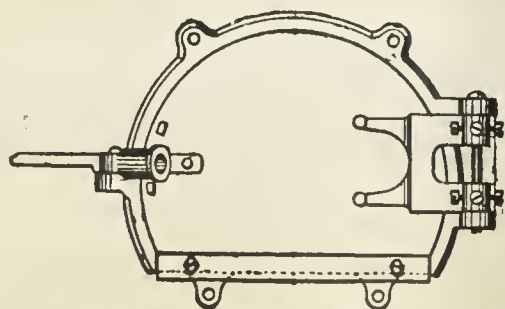

Brenner Self-Sealing Retort Door.

WILLIAM B. LUNDIE, Superintendent of the 42d Street Station of the Consolidated Gas Company, of New York, writes, under date of Jan. 4, 1889:

"We have 320 Brenner Self-Sealing Lids in use at this Station, built by the Smith & Sayre Mfg. Co. They require very little attention, and are the best of the kind that I have seen, giving entire satisfaction."

GAS WORKS APPARATUS AND CONSTRUCTION.

GAS WORKS APPARATUS AND CONSTRUCTION.

JAMES R. FLOYD & SONS,

(SUCCESSORS TO HERRING & FLOYD)

Oregon Iron Works,

W. 20th & 21st. Sts., bet. 10th & 11th Aves.,

NEW YORK CITY.

Engineers and Contractors

FOR THE

CONSTRUCTION OF GAS WORKS.

MANUFACTURERS OF

All Kinds of Castings and General Ironwork

FOR

GAS APPARATUS.

Bench Castings, Regenerative and Half Regenerative Furnace Castings.

Condensers, Scrubbers, Purifiers, Street Drips and Connections,

Valves,

Hydraulic Hoisting Purifier Carriage, Self-Sealing Retort Lids, Improved Valve Stand and Indicator,

Seller's Cement.

Plans, Specifications, and Estimates furnished for Construction of New or Alteration of Old Works.

CONTINENTAL IRON WORKS.

THOS. F. ROWLAND, Prest.

WARREN E. HILL and CHAS. H. CORBETT, V-Prests.

THOS. F. ROWLAND, JR., Sec. & Tr

P. O. Station G., BROOKLYN, N. Y.

ENGINEERS AND MANUFACTURERS OF

Gas Holders

CONDENSERS, SCRUBBERS, VALVES,

PURIFIERS, SELF-SEALING RETORT LIDS

Hydraulic Mains,

And all other articles connected with the manufacture and distribution of Gas.



H. RANSHAW, Prest. & Mangr.

WM. STACEY, Vice-Prest.

T. H. BIRCH, Asst. Mangr.

R. J. TARVIN, Sec. & Treas.

STACEY MFG. CO.,

MANUFACTURERS OF

Single and Telescopic Gasholders,

IRON ROOFS, BRIDGES, LAMP POSTS,

Water and Oil Tanks, Coal Elevator Cars,

COKE CRUSHERS, BENCH CASTINGS,

And all kinds of Wrought and Cast Iron Work used in the erection of Coal and Oil Gas Works Rolling Mill Machinery and Heavy Castings a Specialty.

Foundry:

33, 35, 37 & 39 Mill Street.

Wrought Iron Works:

16, 18, 20, 22, 24 & 26 Ramsey Street:

Cincinnati, Ohio.

Bouton Foundry Co.,

FOUNDERS AND MACHINISTS,

CHICAGO, ILL.

Gas Works Apparatus,

PURIFIERS, CONDENSERS,

Bench Work

SPECIALS, LAMP POSTS,

SCRUBBERS,

Iron Roofs and Floors.

Plans and Estimates furnished for new works or extensions of old works.

1842. DEILY & FOWLER, 1889.

Laurel Iron Works.

Address, No. 39 Laurel Street, Philadelphia, Pa.

BUILDERS OF

GASHOLDERS,

Single and Telescopic.

Holdings Built 1884 to 1888, Inclusive:

- | | | | | |
|----------------------------|-----------------------------|---------------------------|--------------------------|------------------------|
| Newport, R. I. | Long Island City, N. Y. | Port Chester, N. Y. | Malden, Mass. | West Chester, Pa. (2d) |
| Portland, Oregon. | Macon, Ga. | New Rochelle, N. Y. | Paducah, Ky. | Lancaster, Pa. (3d) |
| Allegheny, Pa. (2d.) | York, Pa. | Salem, N. J. (3d) | Norwich, Conn. | Tacony, Pa. (two) |
| Atlanta, Ga. (2d.) | Chester, Pa. | Omaha, Neb. (2d) | Seattle, W. T. | Mount Vernon, N. Y. |
| N.Y. City (Central Gas Co) | Hazleton, Pa. (2d.) | Lynn, Mass. (2d) | San Diego, Cal. | Binghamton, N. Y. |
| Lynchburg, Va. (2d.) | Staten Island, N. Y. | Little Rock, Ark. | Northern Gas Lt. Co., of | Concord, N. H. |
| Saylesville, R. I. | Saugerties, N. Y. | Irrington, N. Y. | New York, N. Y. | Dover, Del. (2d) |
| Rondout, N. Y. | Clinton, Mass. (Lan. Mills) | South Boston, Mass. | Westerly, R. I. | Calais, Me. |
| Atlantic City, N. J. | Chattanooga, Tenn. | Rye, N. Y. (2) | Willimantic, Conn | New London, Conn. (2d) |
| Augusta, Ga. | Galveston, Texas. (3d.) | Woodstock, Ont. | Montclair, N. J. | West Chester, N. Y. |
| Waltham, Mass. (2) | Omaha, Neb. | Malden, Mass. | Attleboro, Mass. | Bay Shore, L. I. |
| Mahanoy City, Pa. | Fort Plain, N. Y. | Staten Island, N. Y. (2d) | Santa Cruz, Cal. | Washington, D. C. |
| New Castle, Pa. | Brunswick, Ga. | Woodstock, Ont. | Erie, Pa. (2d) | |

WM. HENRY WHITE,

No. 32 Pine Street, - - - New York City.

ENGINEER AND CONTRACTOR FOR THE

Erection and Extension of Gas, Water, and Electric Light Works.

SOLE REPRESENTATIVE OF THE

McILHENNY REGENERATOR FURNACE PATENTS

And the Martin Water Gas Process.

Edison Incandescent and American Arc Electric Light Plants Installed.

Correspondence with Gas Companies contemplating extending or improving their Plants respectfully invited. Plans and Estimates Furnished.

GAS COALS.

CANNEL COALS.

GAS ENRICHERS.

JAMES D. PERKINS. **PERKINS & CO.,** F. SEAVERN. S.
228 & 229 Produce Exchange, New York.

Cable Address, "PERKINS, NEW YORK."

Post Office Box 3695, New York.

GENERAL SALES AGENTS FOR

The Youghioghenny River Coal Company's

OCEAN MINE YOUGHIOGHENY GAS COAL.

HON. W. L. SCOTT, Prest.

M. H. TAYLOR, Vice-Prest.

This Colliery is located at SCOTT HAVEN, PA., in the center of the Youghioghenny Gas Coal District, and produces the ONLY RELIABLE YOUGHIOGHENY COAL for gas purposes. (See Map on p. 87 of this JOURNAL, Feb. 16, '85.)

POINTS OF SHIPMENT,

Locust Point, BALTIMORE.

Pier No. 62, PHILADELPHIA.

Also, SOLE AGENTS for the

**BRECKENRIDGE CANNEL,
OF KENTUCKY.**

Within the past two years we have delivered this Cannel to over ONE HUNDRED COMPANIES IN THIRTY-THREE DIFFERENT STATES, and it is now in use in some of the large Gas Works

On the Continent and in South America,

where it successfully competes with the Australian Shale. It is the ONLY AMERICAN GAS CANNEL of sufficiently high grade to warrant EXPORTATION TO EUROPE AND SOUTH AMERICA, and it is the only economical substitute for OIL OR NAPHTHA. ONE GROSS TON will produce

10,000 Cubic Feet of 75 Candle Gas,	} equal to {	750,000 Candle Feet of Gas, and 26 Bushels of merchantable Coke weighing 900 Pounds
or 12,500 " " 60 " "		
or 15,000 " " 50 " "		

This is the ONLY GAS CANNEL that will produce a REALLY MERCHANTABLE COKE. It can be delivered in parcels of one carload or more to any point in the United States or Canada. Cargo shipments of any size required can be made from NEW YORK, PHILADELPHIA, BALTIMORE, or NEWPORT NEWS. Samples will be sent and particulars of price, etc., forwarded upon application to above address.

JAMES & WILLIAM WOOD,
Gas and Cannel Coal Contractors,

No. 40 St. Enoch Sq., Glasgow. No. 2 Talbot Court, London.

Proprietors of the BATHVILLE COLLIERIES (which produce the celebrated BOGHEAD CANNEL), Shields, Shieldmuir, Drumpeller, and other Collieries. This Firm offer

STANDARD CANNELS,

Unequaled as Gas Enrichers.

Also, WEST FAIRMONT GAS COAL, of W. Va.

Analyses, prices, and all further information furnished on application to

Agency for U. S., Room 93, Nos. 2 & 4 Stone St., N.Y. City.

The Standard Oil Company,

REFINERS OF

NAPHTHA AND GASOLINES.

ALSO MANUFACTURERS OF

A Special Grade of Naptha for Gas Companies

FOR ENRICHING COAL GAS.

Correspondence solicited.

No. 43 Euclid Avenue, Cleveland, Ohio.

To Gas Companies.

We make to order CAP BURNERS to burn any amount under a stated pressure. Send for samples.

Also, SERVICE CLEANERS, DRIP PUMPS, and STREET MAIN PROVING APPARATUS.

O. A. GEFROER,

248 N 8th Street, Phila., Pa.

COKE CRUSHERS.

GAS COALS.

GAS COALS.

Newburgh Orrel Coal and Coke Co.
 MINERS AND SHIPPERS OF
STEAM, SMITHING, AND GAS COALS,
 Foundry and Crushed Coke.
 Home Office, 33 S. Gay Street, Baltimore, Md.
J. HARRY LEE, President.
 Shipping Wharves, Locust Point, Baltimore.

The Despard Gas Coal Co.,
 MINERS AND SHIPPERS OF
DESPARD GAS COAL,
 AND MANUFACTURERS OF
COKE.
 MINES, Clarksburg, Harrison Co., W. Va.
 WHARVES, Locust Point, Baltimore, Md.
 OFFICE, 225 E. German St., " "
 ROUSSEL & HICKS, } AGENTS. } BANGS & HORTON,
 71 Broadway, N. Y. } 60 Congress St., Boston.

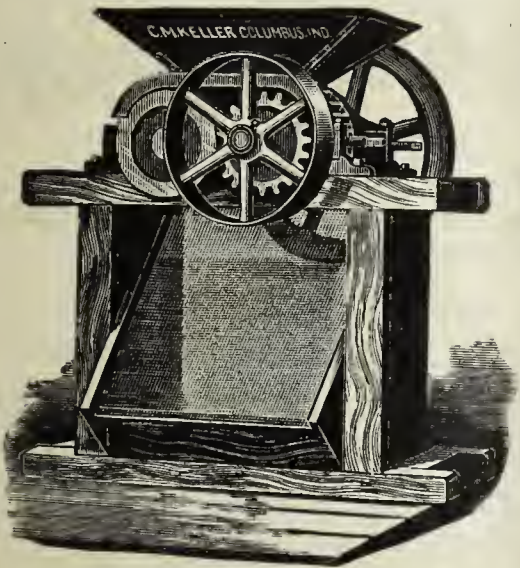

Keller's Adjustable Coke Crusher.
SIMPLE, STRONG, AND DURABLE.
 O. M. Keller, Sec. & Supt. Gas Lt. & Coke Co. Columbus, Ind.
 Correspondence Solicited.

King's Treatise on Coal Gas.
 The most complete work on Coal Gas ever published
 Three Vols. Bound, \$30.

BOOKS.

DISTILLATION OF COAL TAR AND AMMONIACAL LIQUOR.
 By GEORGE LUNGE. Price \$12.50.
A TREATISE ON THE COMPARATIVE COMMERCIAL VALUES OF GAS COALS AND CANNELS.
 By DAVID A. GRAHAM. 8vo., Cloth. Price \$3.
 Orders for these books may be sent to this office.
A. M. CALLENDER & CO.,
 42 PINE ST., N. Y. CITY

THE
PENN GAS COAL CO.
 OFFER THEIR
Coal, Carefully Screened & Prepared for Gas Purposes.

Their Property is located in the Youghiogeny Coal Basin, near Irwin and Penn Stations on the Pennsylvania Railroad, and on the Youghiogeny River.

Principal Office:
209 SOUTH THIRD STREET, PHILA., PA.

Points of Shipment:
 Pennsylvania Railroad Piers; Greenwich Wharves, Delaware River; Pier No. 1 (Lower Side), South Amboy, N. J.

Chesapeake & Ohio Railway Coal Agency,

FOR THE SALE OF THE
Superior Kanawha Gas Coals, Cannelton Cannel,
Also, SPLINT AND STEAM COALS
 From the Kanawha and New River Regions, on the line of the Chesapeake & Ohio R'way.
C. B. ORCUTT, General Agent, - - No. 1 Broadway (Room 217) New York City.

FRANCIS H. JACKSON, Prest. EDMUND H. MCCULLOUGH, V.-Prest. CHAS. F. GODSHALL, Treas. H. C. ADAMS, Sec.

THE WESTMORELAND COAL CO.

Chartered 1854.
Mines situated on the Pennsylvania and the Baltimore and Ohio Railroads, in Westmoreland County, Penn.

POINTS OF SHIPMENT:
 PHILADELPHIA, BALTIMORE, SOUTH AMBOY, N. J.,
 WATKINS (SENECA LAKE), N. Y.

Since the commencement of operations by this Company its well-known Coal has been largely used by the Gas Companies of New England and the Middle States, and its character is established as having no superior in gas-giving qualities, and in freedom from sulphur and other impurities.

Principal Office, 224 South 3d St., Phila., Pa.

The American Gas Engineer and Superintendent's Handbook.

By WILLIAM MOONEY.
 Consisting of Rules, Reference Tables, and Original Matter Pertaining to the Manufacture, Manipulation, and Distribution of Illuminating Gas.

350 Pages, Full Gilt Morocco. \$3.00.

A. M. CALLENDER & CO., 42 Pine St., N. Y.

GAS METERS.

GAS METERS.

GAS METERS.

ESTABLISHED 1859.

JOHN J. GRIFFIN & CO.,

Nos. 1513, 1515, 1517, & 1519 Race St., PHILADELPHIA.
 No. 52 Dey Street, NEW YORK. No. 75 North Clinton Street, CHICAGO.

Manufacturers of Meters for Measuring Gas

IN ANY VOLUME.

EXPERIMENTAL APPARATUS FOR QUANTITATIVE AND QUALITATIVE ANALYSIS.

Provers, Gauges, Registers, Etc.

Careful and Prompt Attention paid to the Repairing of all kinds of Meters and Apparatus.

Estimates Cheerfully Furnished.

Dry Gas Meters.

With 40 years' experience and the best facilities for manufacturing, is enabled to furnish reliable work and answer orders promptly.

NATHANIEL TUFTS,*No. 153 Franklin Street, Boston, Mass.,*

MANUFACTURER OF

DRY GAS METERS.

Station Meters of any Capacity.

Test and Experimental Meters, Pressure Registers, Pressure Gauges, Pressure and Vacuum Gauges.

METER PROVERS, PHOTOMETERS, STREET LANTERNS, ETC., ETC.

Patent Cluster Lanterns for Street Illumination.

HAROLD J. BELL.

BELL & JONES,

S. LEWIS JONES.

No. 12 North Ninth Street, Philadelphia, Pa. Works at Royersford, Pa.

MANUFACTURERS OF

GAS METERS, STATION AND EXPERIMENTAL METERS,**Meter Provers, Pressure Gauges, and All Other Gas Appliances in Our Line.**

WE REPAIR ALL KINDS AND MAKES OF METERS, AND THE WORK GUARANTEED.

High Pressure Meters for Natural Gas, in Iron Cases, guaranteed to stand 300 lbs. Pressure.
 Gas Cooking and Heating Stoves, Hot Plates, Cake Griddles, Waffle Bakers, Boiling Stoves, Laundry and Tailors' Iron Heaters. Hotel and Cafe Ranges a Specialty.

Correspondence Solicited.

Estimates Furnished.

CHARLES E. DICKEY.

JAMES B. SMALLWOOD.

CHARLES H. DICKEY.

THE MARYLAND METER AND MANUFACTURING CO.

Established 1866.

BALTIMORE, North & Saratoga Sts.

CHICAGO, 197 Michigan Street.

NEW YORK, 766 Broadway.

BOSTON, 4 Central Street.

ST. LOUIS, 1115 Olive Street.

SAN FRANCISCO, 330 Pine Street.

CONSUMERS' & STATION METERS, PRESSURE GAUGES, Etc., Etc.**"Success" and "Perfect" Gas Stoves.**

GAS METERS.

GAS METERS.

GAS METERS.

GEO. J. MCGOURKEY, Prest.

WM. H. MCFADDEN, Vice-Prest. (Phila.)

WM. N. MILSTED, Gen. Supt. and Treas. (New York).

WM. H. DOWN, Sec.

THE AMERICAN METER CO.

WET AND DRY GAS METERS.

PRESSURE REGISTERS.

METER PROVERS.

STATION METERS.

PRESSURE & VACUUM REGISTERS.

PORTABLE TEST METERS.

EXHAUSTER GOVERNORS.

PRESSURE & VACUUM GAUGES.

EXPERIMENTAL METERS.

DRY CENTER VALVES.

CRESSON GAS REGULATORS.

AMMONIA TEST METERS.

GOVERNORS FOR GAS WORKS.

MARSLAND WATER METERS.

BAR & JET PHOTOMETERS.

Manufactories:

512 West 22d St., N. Y.

Arch & 22d Sts., Phila.

GAS STOVES.

SUGG'S "STANDARD" ARGAND BURNERS,

SUGG'S ILLUMINATING POWER METER,

Wet Meters, with Lizar's "Invariable Measuring" Drum.

Agencies:

177 Elm Street, Cincinnati.

244 & 246 N. Wells Street, Chicago.

310 North Second Street, St. Louis.

222 Sutter Street, San Francisco.

HELME & McILHENNY,

(Established 1848.)

GAS METER MANUFACTURERS,

Nos. 1339 to 1349 Cherry Street, Philadelphia, Pa.,

WET AND DRY GAS METERS, STATION METERS, EXPERIMENTAL METERS, METER PROVERS,

Center Seals, Pressure Registers, Governors, Indicators, Photometers, and all other kinds of Apparatus for use in Gas Works.

FOULIS' PATENT STATION AND DISTRICT GOVERNORS.

REPAIRING DEPARTMENT.—We employ a special force of skilled workmen repairing meters of all makers.

WM WALLACE GOODWIN, Prest. and Treas.

WM. H. MERRICK, Vice-Prest.

S. L. JONES, Sec.

S. V. MERRICK, Supt.

THE GOODWIN GAS STOVE AND METER CO.

Successors to W. W. GOODWIN & CO.

1012, 1014 and 1016 Filbert St., Phila., Pa.

142 Chambers St., New York City.

76 Dearborn, St., Chicago, Ills

WALDO BROTHERS, Agents, 88 Water Streets, Boston, Mass.

MANUFACTURERS OF

DRY AND WET GAS METERS,

Station Meters (square, cylindrical, or in staves), Glazed Meters, King's and Sugg's Experimental Meters, Lamp Post Meters, etc., etc. Meter Provers (sizes 2, 5, and 10 feet), Pressure Gauges of all kinds, Pressure Registers, Pressure and Vacuum Registers, Pressure Indicators

(sizes 4, 6, and 9 inch), King's Pressure and Vacuum Gauges, Dry and Wet Center Seals, Dry and Wet Governors, Exhauster

Governors, Photometers of all descriptions. Letheby's Sulphur and Ammonia Test Apparatus complete. Also, Testing

and Chemical Apparatus of all kinds, and of the most perfect description, for all purposes relating to Gas.

Manufacturers of the "SUN DIAL" GAS STOVES, for Cooking and Heating.

Goodwin's Improved Lowe's Jet Photometer.

Agents for Bray's Patent Gas Burners and Lanterns.

Special attention to Repairs of Meters and all Apparatus connected with the business. All work guaranteed first-class in every particular. Orders filled promptly.

G. B. EDWARDS, Manager, New York.

S. S. STRATTON, Manager, Chicago.

D. McDONALD & CO.,

GAS METER MANUFACTURERS.

(Established 1854.)

51 Lancaster St., Albany, N. Y. 34 & 36 West Monroe St., Chicago, Ill.

STATION METERS, EXPERIMENTAL METERS, METER PROVERS, PRESSURE & VACUUM REGISTERS, PRESSURE GAUGES, ETC

Also STAR GAS STOVES, RANGES, and HEATING STOVES.

We use only the very best materials, and employ the most skilled labor, and by our long experience (32 years) and personal supervision of every detail, we feel justified in assuring the public that our goods will give perfect satisfaction. Every Meter emanating from our establishment will bear the State Inspector's Badge, and will be fully warranted by us. Our Annual and Calendar will be sent to Gas Companies upon application.

GAS STOVES.

GAS STOVES.

GAS STOVES.

THE GOODWIN GAS STOVE AND METER CO.,

1012-18 Filbert St., Phila., 142 Chambers St., N. Y., 76 Dearborn St., Chicago.

Agents, WALDO BROTHERS, 88 Water Street, Boston.

WM. W. GOODWIN, Pres. and Treas.
W. H. MERRICK, Vice-Pres.
S. LEWIS JONES, Sec.

SAMUEL V. MERRICK, Supt.
G. B. EDWARDS, Mang'r, N. Y.
S. S. STRATTON, Mang'r, Chicago.

SOLE MANUFACTURERS OF THE

"SUN DIAL" GAS STOVES,

The Most Economical, Efficient, and Durable Gas Stove Made.



GAS COOKING STOVE, No. 8 C.

SIZE.

Stove.	Oven.	Roaster.	Top.	Length over Extension Shelves,
37 in. high.	12 in. high.	12 in. high.	24 in. long.	36 in.
20 in. wide.	17 1/2 in. wide.	18 in. wide.	21 in. wide.	
	12 in. deep.	13 in. deep.		

This Stove has four burners on top, and double oven burner. Consumption of gas with all burners in use, 42 feet per hour, at 1 inch pressure. The top is made in sections, so that a greater variety of cooking utensils may be used. By lifting out the covers and crosspieces and putting in a suitable forked ring, which is sent with each stove, a wash boiler or other large utensil may be set over two burners. Our No. 87 GRIDDLE also fits in the same position. The roasting oven is provided with a cast-iron door.

All Fittings are Nickel-Plated.

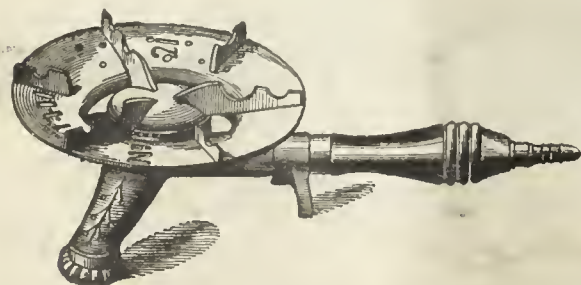

"RADIANT" BOILING STOVE, WITH REGENERATIVE BURNER.

Size, 6 1/2 inches diameter, 8 inches high. Consumption, 6 feet per hour at 1 in. pressure.

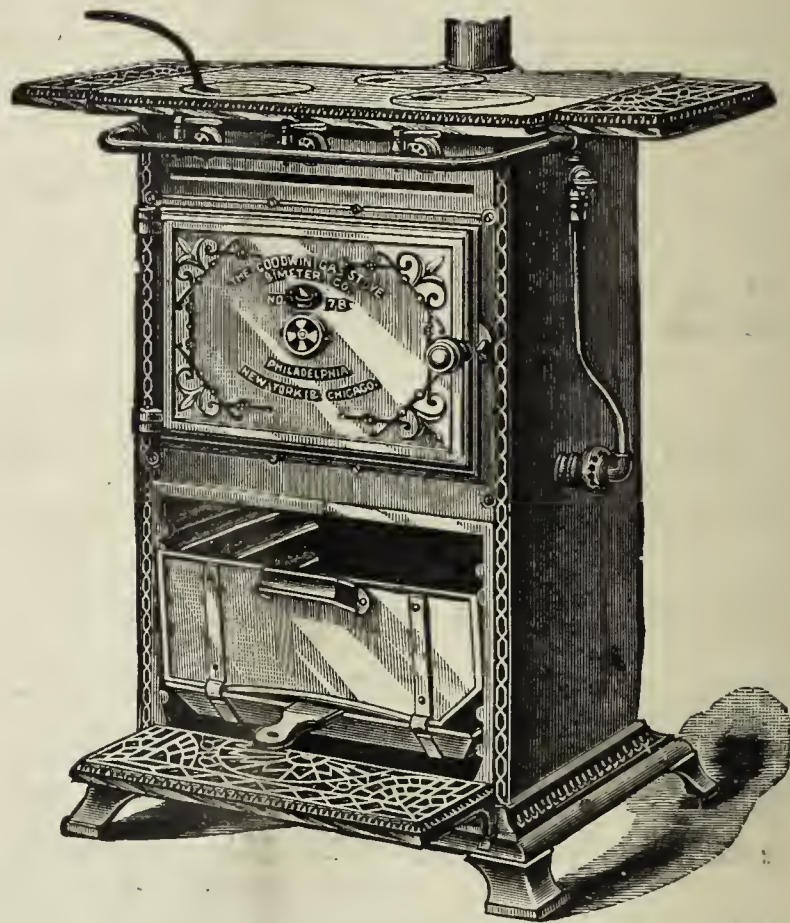

GAS COOKING STOVE, No. 7 B.

SIZE.

Stove.	Oven.	Roaster.	Top.	Length over Extension Shelves,
31 in. high.	9 1/2 in. high.	10 in. high.	21 in. long.	32 in.
17 in. wide.	14 1/2 in. wide.	15 in. wide.	16 in. wide.	
	12 in. deep.	13 in. deep.		

This Stove has three boiling burners in the Top or Hot Plate, and one single oven burner.

This cut represents our New Style Cooking Stove. As will be seen, it has an ornamented cast-iron Base and Front, and extension shelves. The Oven Burner, which is atmospheric (unless otherwise ordered), is of an entirely new and improved pattern (patent). The ovens are of greater capacity than those of the old style. The Top, in conjunction with the Outlet Pipe, is designed to carry off all the products of combustion, if desired, but they are also supplied with a loose ring which converts it into an ordinary open top stove.

The consumption of this Stove is 35 cubic feet per hour at 1 inch pressure, with all Burners in use.

All Fittings are Nickel-Plated.

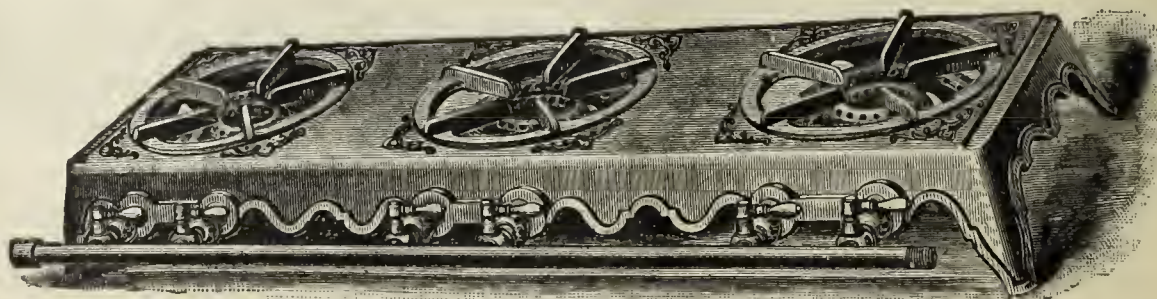

HOT PLATE, No. 111.

Size, 36 in. long, 12 in. wide, with three double burners, 6 taps. Consumption, with all burners in use, 36 cubic feet per hour, with 1 in. pressure. 1/2 in. supply pipe should be used where the pressure is 1 in. or over.

31-
4
170
171
12
58.9
5010

THE AMERICAN

GAS LIGHT JOURNAL

REDMAN & KENNY, N. Y.

PUBLISHING OFFICE NO. 42 PINE STREET

DEVOTED TO THE INTERESTS OF ILLUMINATION, VENTILATION, WATER SUPPLY AND DISTRIBUTION, & GENERAL SCIENCE.

VOLUME LIII.—No. 10.
Whole No. 770.

NEW YORK, MONDAY, MARCH 10, 1890.

{ \$3 PER ANNUM,
IN ADVANCE. }

A. M. CALLENDER & CO., Proprietors. C. E. SANDERSON, Manager.
JOS. R. THOMAS, C.E., Editor. T. J. CUNNINGHAM, Asst. Editor.

ENTERED AT THE POST OFFICE AT NEW YORK, N. Y.
AS SECOND CLASS MATTER.

Published on each Monday of the year, at No. 42 Pine Street, N. Y.

Terms of Subscription, including Postage.—For the United States and Canada, \$3 per annum. European countries, \$4.50 (19 shillings—22½ francs). All payments to be made in advance. Single copies, 10 cents.

Remittances should be made either by post-office order, registered letter, or bank draft on New York, payable to the order of A. M. Callender & Co.

Collections are invariably made directly from this office, for subscriptions, advertisements, etc. We have agents to solicit the same, but they are not authorized to receipt for money.

CONTENTS.

An Asterisk (*) denotes an illustrated article.

OFFICIAL NOTICES—

Southwestern Gas Association	313
Ohio Gas Light Association.....	313

EDITORIALS—

Briefly Told.....	314
The Meeting at Dallas, Tex.—The Latest Gun from Toledo—The Slater and Parker Papers—Electric Light Installations, etc.	
Facts and Figures Connected with the Installation and Operation of an Electric Light Plant, by John J. Power.....	314
Sulphate of Ammonia as Manure.....	315
Twentieth Annual Meeting, New England Association of Gas Engineers—Official Report, Revised by the Secretary—Continued from page 286.....	316

First Day, Morning Session: Revivification of Oxide of Iron, by Waido A. Larned—Discussion—Some Experiments in the Photometer Room, by N. W. Gifford—Discussion. First Day, Afternoon Session: Difference in the Eastern and Western Methods of Management of Gas Works, by E. G. Pratt—Why I shall Make Water Gas, by A. B. Slater—A Few of the Advantages of Water Gas over Coal Gas for Small Works by F. H. Parker—Joint Discussion—Various Methods of Introducing Gas Stoves, by H. A. Norton—Discussion—Management of a Small Gas and Electric Light Plant, by S. J. Fowler—Discussion—Election of Officers—World's Fair Committee—Badges—Printing the Papers—News from the Absent Secretary.

ITEMS OF INTEREST FROM VARIOUS LOCALITIES..... 327

A 6 Per Cent. Dedham Stock—And a Moral Therefrom—Obituary Note, Dr. H. H. Button—In the Matter of Baltimore's Gas Supply—Notable Engineering Feat—The Dogs to be Asphyxiated—The Story of a Meter—Altering the Massachusetts Carbonic Oxide Laws—Sale of the Crawfordsville (Ind.) Plant—In Control at Media, Pa.—Destruction of the Freeport (Ills.) Company's Electric Annex—Sale of the Indianapolis Plants—They may Rebuild—Opposition Works, St. Joseph, Mo.—Explosion at the Tacony Fuel Gas Works—Public Lighting, Troy, N. Y.—And Many Other Items.	
Coke Brick for Furnace Linings	329
Recent Patent Issues.....	329
The Market for Gas Securities.....	330

[OFFICIAL NOTICE.]

Ohio Gas Light Association.

OFFICE OF SECRETARY,
COLUMBUS, O., February 22, 1890.

To Members of the Ohio Gas Light Association:

Gentlemen—As previously announced, the Sixth Annual Meeting of this Association will be held at Toledo, O., beginning at 10 A.M., March 19, 1890, and continuing two days. Boody House will be the headquarters of the meeting, the various sessions of which will be held in a very suitable room in the same hotel. Members and others desiring to attend are advised to write well in advance for rooms.

The following papers have been promised for the meeting:

1. "Theory and Practice in Gas Management," J. M. Bate, Supt. Gas and Coke Company, Canton, O.
2. "Municipal Control of Lighting," H. Wilkiemeyer, Supt. Gas Light and Coke Company, Portsmouth, O.
3. "Combination of Gas and Electric Lighting in a Small Town," George W. Bowers, Sec. Gas and Electric Light Company, Hillsboro, Ohio.
4. "Our New Coal Gas Works," G. A. Hyde, Engineer Gas Light and Coke Company, Cleveland, O.
5. "Advantages of a Combined Coal and Water Gas Plant," Geo. Light, Asst. Supt. Gas Light and Coke Company, Dayton, O.
6. "Another Year with Fuel Gas," Chas. H. Evans, Manager National Gas Company, Jackson, Mich.
7. "Ohio Street Lighting Statistics," W. C. Hedges, Secretary Gas Light Company, Mansfield, O.
8. "Graduated versus Uniform Rates," Chas. R. Faben, Jr., Supt. Gas Light and Coke Company, Toledo, O.

The following questions have been proposed for the "Question Box:":

1. At what point in the works is the best place for the exhauster?
2. In a lighting territory covered by illuminating gas and the incandescent electric light, which seems to be in the ascendancy?
3. Does a fine gas of 23 to 25-candle power help check the invasion of the incandescent electric light?
4. Should we not confine the work of our Association to the important interest it was established to promote, viz.: gas lighting and the manufacture of coal gas?
5. What system of electric lighting is best for adoption by gas companies?
6. Are cast iron pipes better and cheaper than wrought pipes for gas mains of 2 to 4 inches in diameter?
7. Does it pay to coat gas mains with coal tar?
8. What is the average life of a meter in constant use, with ordinary good care?
9. Is not illuminating gas of good candle power, sold at a reduced price for fuel, the true solution of the fuel gas problem?
10. Which is the correct method of tapping mains, on top or at the side?
11. Is the Welsbach burner with natural gas a success, and what proportion of the lighting does it do in towns having both natural and artificial gas?

[OFFICIAL NOTICE.]

Southwestern Gas Association.

OFFICE OF SECRETARY, GALVESTON, TEXAS, Feb. 24, 1890.

The annual meeting of the Southwestern Gas Association will be held in Dallas, Texas, March 12 and 13, 1890. The arrangements for the meeting are now being perfected. Headquarters will be at the Windsor Hotel.
C. P. RUSSELL, Sec'y.

Other interesting questions have been proposed, which will be presented at the meeting, and members are requested to come prepared to participate in the discussion of the above papers and questions.

Provision has been made for an exhibit, in connection with the meeting, of all kinds of gas appliances and apparatus, a large room on the ground floor, a few doors from the hotel, having been secured for this purpose. No charge for floor space will be made to exhibitors, and those desiring to avail themselves of this excellent opportunity of displaying their specialties will consign their goods and address their communications to Mr. Chas. R. Faben, Jr., Supt. Gas Light and Coke Company, Toledo, O., who has the matter in hand, and who will arrange the exhibit to the best advantage of all concerned.

In addition to this exhibit there will be other objects of much interest to our members and visitors, and the meeting promises to be in every way successful. It is hoped that every member will show his appreciation of what has been done, by being present; and gas companies not heretofore represented at our annual gatherings will be profited by sending a representative to this meeting.

A cordial invitation is constantly extended to all who may desire to become members of the Association, to do so, and the Secretary would be pleased to hear from any such persons.

IRVIN BUTTERWORTH, Sec'y.

BRIEFLY TOLD.

THE MEETING AT DALLAS, TEX.—Before the current issue of the JOURNAL will have been in the hands of a large number of its readers the members of the Southwestern Association will be in session at Dallas, Texas, the convention days for the same having been fixed at the 12th and 13th insts. There is no blinking the fact that the gathering might have been more extensively advertised, with the certain result that the attendance would have been thereby benefited. Admitting the paucity of notification, however, it is gratifying to be able to say that it was not from neglect of the Secretary, nor from any inclination on his part to lukewarmness in respect to advancing the Association. Secretary Russell, just at the time when his best efforts would be put forth in preparing for the meeting, made a change in his business relations that caused him to leave Houston in order that he might re-attach himself to the Galveston Company. The disorganization consequent upon this action is the good cause for his seeming dilatoriness in respect to advertising the Dallas gathering. In the meantime, both President Enfield and Secretary Russell have not been idle in correcting the earlier omission, and so well have their efforts been responded to that, from our current advice, we confidently look forward to a good and valuable meeting. The gas makers of the great Southwest are very differently situated from their brethren of the East, West and South; and more especially does this remark apply to Texas, where the companies are, in common with other manufacturing interests, largely at the mercies of the railroads. The time will come, however, when engineering skill, backed by ample capital, will emancipate Texas from the iron (or steel) clutch of the railroad magnates, who, with rare blindness, seem bent on withering the resources that it should be their closest aim to foster. No matter whether it be a Willetts, of San Antonio, with his cherished plan of "a corral in the sea," or some one else, a Moses is sure to show the people of the Lone Star State the high road to competition in commerce. This oddity of position ought to cement the gas men of that section in more than ordinarily close counsel. We hope that the meeting will be a successful one, and shall look forward to a report of the proceedings with eager anticipation.

THE LATEST GUN FROM TOLEDO.—During the week we have received a circular from Secretary Butterworth—certainly no one can accuse that gentleman of a lack of attention to his duties as Secretary of the Ohio Association—which is in the nature of a "personal talk" between the members and himself. As a circular, then, we are unable to print it, because of the fatal words "not for publication." As it contains some matters that are worthy of especial mention here, why, we will make due note of these, and feel that in doing so the injunction "not for publication" will not have been infringed. In the first place, the Secretary notes that the Boody House, which has been selected as headquarters and place for meeting, is in all respects a first-class hotel, and that its ordinary rates are from \$3 to \$5 per day, according to the location of the rooms. The Committee of Arrangements, however—no doubt Charlie Faben could tell something about this—seem to have convinced the Boody House proprietor that gas men are such desirable fellows to have about a hotel, that he could see his way clear to making a concession. In any event, a uniform rate of \$3 per day has been arranged for the members and their guests. There is possible trouble in the suspicion that the Boody House may not be large enough to comfortably receive all those who will seek its shelter. Should there be an "overflow" that

contingent can undoubtedly count on good quarters at the Madison House, which is close to the Boody. The Secretary gives it as his belief "that the meeting will be very very interesting and profitable," and in that belief we heartily share. He also asserts that the exhibit of gas appliances and apparatus promises to be very large and interesting. The outing part of the meeting will include a visit to the factory and show-rooms of the Central Chandelier Company. Indeed, there is every indication that the Ohio's Sixth Annual will not be in any respect inferior to the rousing gatherings of its first half decade.

THE SLATER AND PARKER PAPERS.—In our current installment of the proceedings of the New England meeting are many interesting papers and much lively discussion that are sure to be closely read and remembered. In selecting at this time the papers noted in the heading we do so from the fact that one or two points in each seem to call for especial emphasis. Mr. Slater is nothing if not frank, and in his frankness is never illogical. His reference to the "feeling of hostility and even bitterness engendered by the early introduction of water gas" paves the way for a later expression in his paper that is worth reproducing here. This is: "I will say, however, in passing, that in my judgment the feelings to which I referred, of opposition to water gas, etc., etc., were not engendered so much by the gas, or its composition, *per se*, as by the aggressiveness displayed by its early patentees and advocates in forcing its introduction by questionable methods, even before it had reached its present perfected state." And the "bitterness" that was thus engendered had reason for its existence. Questionable, indeed, were the methods employed; and those methods are as much in disfavor to-day amongst men of probity as they were in the early eighties. No; the objection was not so much against the process of manufacture as against the "processes" of the financiers who were interested in its development. Mr. Slater, however, puts the matter so concisely and truthfully that we might take leave of that portion of the subject at this point. We do not concede the soundness of his conclusions about the carbonic oxide content in water gas, which will surely be availed of before long by the incandescence electric lighting promoters, who have armed themselves with some striking figures as to its potency. In fact we think the least said about carbonic oxide the better it will be for the gas maker. In the Parker paper we consider his experiences in the manufacture of coal and water gas, have been, to say the least, one-sided, with the leaning all in favor of water gas. In fact, if the figures of this year's report of the Massachusetts Board of Gas and Electric Light Commissioners are to be accepted as fair, we fail to see wherein the new method is in any essential respect an improvement over the old, save in the instance of the greater ease with which a water gas plant can be operated. If facility of operation is the desideratum then the new plan has it. But we nevertheless incline to the view that greater advances are in store for the coal gas process than for its co-adjutor. The long and short of it, however, is that both will likely work in harmony and to their mutual benefit.

ELECTRIC LIGHT INSTALLATIONS, ETC.—We are in receipt, from the D. Van Nostrand Company, of this city, of a copy of Sir David Salomon's (Bart., A.I.C.E., etc.) "Practical Handbook of Electric Light Installations, and the Management of Accumulators." The book, which is now in its fifth edition, has met with great favor; and this seems to have been fairly earned. Sir David treats his subjects in a manner well calculated to gain the confidence of the reader, and we have no hesitation in recommending the book. It is well printed and profusely illustrated. The Van Nostrand Company are the agents in America for the work, the retail price of which is \$1.50.

Facts and Figures Connected With the Installation and Operation of an Electric Light Plant.

By Mr. JOHN J. POWER, Supt. Natchez (Miss.) Gas Co.

Your issue of February 17th, contains a letter from Mr. J. Smart, President Port Hope (Ont.) Gas Company, appealing to gas managers who have had experience as to cost of installing and operating an electric light plant.

Having built and managed the Natchez Gas Company's electric light station here (though somewhat larger than the one named by Mr. Smart), my experience in that branch of our works may be of some benefit to him, or to some other members of the gas fraternity.

In this connection I would say, that through the columns of your JOURNAL I have been able to gather a varied store of new ideas and information, that many times assisted me in overcoming the difficulties that lie in the gas manager's path; and in this, my first communication, I return my thanks to the JOURNAL and its many able contributors.

and though my crude letter may be wanting in full details, if it is of any assistance it will have accomplished my object in writing it.

The Natchez Gas Light Company, nearly 2 years ago, decided to put in an electric light plant, principally for lighting the streets of our city, which were at that time lit by 110 gas and about 70 coal oil lamps; and after having the same experience as Mr. "S." with the agents of electric lighting companies, they finally chose the Thomson-Houston system, and contracted with that company for a complete outfit of 100 2,000-candle power arc light capacity, the gas company reserving the right to choose the kind of steam boiler and engine to be put in. All the work was done under my supervision. The plant consisted of 1 Hazelton boiler, 125-horse power, and a Beck engine, 100-horse power, with a Stillwell exhaust steam heater and purifier, 3 dynamos—2 of 35-light and one of 30 light capacity—all the lamps and attachments and cost of building to be in the contract, together with 21½ miles of wire. The plant, complete, cost the company \$25,000.

The building, part frame and part brick, is all covered with corrugated iron, 40 by 60 feet; the boiler and pump room is 19 by 40 feet; the space occupied by boiler is 10 feet in diameter. A brick wall divides the boiler from the engine and dynamo room, which occupies the remainder of the building, 40 by 40 feet. Great care was exercised in having good ventilation, which is absolutely necessary for the safety of the dynamos. In putting in foundations for engine and dynamos, I was very careful to have good work performed. The engine foundation is 6 feet deep, on good solid earth, 1 foot of cement and 5 feet of brickwork, laid in cement mortar, every brick shoved and joints struck. The mortar was composed of 1 part cement to 2 of sand. The sides of foundation have a pitch of 3 inches to the foot. The foundations for dynamos were similarly constructed; but only 3 feet deep. To-day those foundations are solid as can be. I have balanced a silver coin on edge on cylinder head of engine when running at a speed of 265 revolutions. We have the Scheiren perforator dynamo belts; and, after a year's hard wear, there is not a flaw or crack to be seen in them.

Our repairs on plant have been very slight, and embrace a new wrist pin in engine, nothing on dynamos; and, except for making some changes on extension shaft of engine, which were necessitated by having to put in another engine to run on incandescent dynamo, might be said to be nil.

Our boiler has proved a great success, making a great saving in fuel; for, from several tests which I have made, both with water evaporation and from card from engine, with Pittsburgh nut and slack (very little nut) we have obtained a horse power for 3.8 lbs. coal consumed. It is easily handled, a very rapid steamer, and, from my knowledge of others of the same make, very durable.

We are now running up to full capacity—84 arcs and 51 incandescents (series) 65-candle power. The city has given us a 5 years' contract, which we obtained after a bitter fight with a rival company, at \$85 per year for 2,000-candle power lights, all night and every night. We have 79 on the streets; also, 17 65-candle power incandescents, at 1½ cents per hour each. The balance of our lights are taken in stores.

Our operating expenses for an average month are as follows:

Engineer	\$80 00
Fireman	50 00
Trimmer (who furnishes his own horse and wagon)	75 00
Lineman (5 days repair line, new lamp ropes, etc.)	10 00
Coal, Pittsburgh slack, at \$3 per ton	175 00
Carbons	70 00
Repairs, new brushes, commutator segments, new globes, etc.	18 50
Oil, \$16, waste, \$3.50	19 50
Total	\$498 00

To this must be added wear on plant, interest on investment, and insurance. So far everything works smoothly, and every visitor to the city claims that we have the best and steadiest lights that they have met with anywhere. The only credit in this connection which I can claim, is that I take especial care to keep everything around the machinery, especially the dynamos, clean and in good trim.

In conclusion, I would say to the intending purchaser of an electric plant, get the best of everything. First, a good system; second, a good steam plant, that will save cost of fuel, which is the heaviest expense in operating; third, suitable buildings, strong, well ventilated and dry; fourth, good men to operate your machinery—it is poor policy to try to get a cheap man, because he is cheap, to run valuable machinery; and last but not least, get the best wire and have it well and securely put up. If of poor quality and poorly put up, it will always be a source of expense, dangerous, and a continued worry to all connected with the plant.

Sulphate of Ammonia as a Manure.

We learn, from the *Journal fuer Gasbeleuchtung*, that the German Gas Association has had presented to it a report of its Committee on the above subject, which was read by Professor Bunte, of Carlsruhe. The funds for the investigation were subscribed by various German gas works, and the work was carried out by the German Agricultural Association, through Professor Marker, of Halle, and Professor Wagner, of Darmstadt. Professor Marker's work was fieldwork, in 40 places all over Germany. In each place a field, as uniform as possible, was divided into two sections, and each of these again into five divisions, each of which had an area of about 3,000 square yards. These plots were used for the study of two questions: one bearing upon the comparative inefficiency of ammonia-sulphate manures in soils containing little or no lime; that is, what is the action of carbonate of lime on the manuring activity of sulphate of ammonia? The result is that lime or marl greatly increases the efficiency of sulphate as a manure.

The year 1888 was very unfavorable for experiments; a late spring, an extraordinarily dry summer, and a heavy rainfall in autumn, which swelled up the crops and predisposed them, especially potatoes, to disease. Still, over all, the comparative statements are worth relating.

Fine powdered lime, 1.6 cwt. per acre, was lightly ploughed in. The variations were: (1) No sulphate, no lime; (2) no sulphate, but lime as above; (3) weak sulphate, no lime; (4) weak sulphate, with lime; (5) strong sulphate, with lime. The "weak" sulphate means, for barley, 80 lbs. sulphate, for beet, oats, potatoes, etc., 120 lbs. per acre; "strong" means 120 lbs. for barley and 200 lbs. for the rest. A phosphate manuring, and in light soil, one with 3.2 cwt. of kainite per acre, ran side by side with the sulphate manuring.

The increases with sulphate were, in pounds per acre:

Oats	546.2 lbs. grain, and 946.7 lbs. straw and chaff.
Barley	203.7 " " " 58.0 " " "
Winter wheat. 158 " " " 234.0 " " "	
Beet-root	197.3 " roots.
Turnips	491.2 " "
Potatoes	646.8 " tubers.

With strong sulphate manuring the increase was still greater.

As to combination of manures, the increases were:

	Lime alone.	Ammonia alone.	Lime and Ammonia.
Barley (grain)	95.7	203.7	535.4
Oats "	147.7	546.2	947.4
Wheat "	59.6	158.0	211.4
Potatoes (tubers)	868.4	646.8	1369.2
Beet (roots)	— 229.6	+ 1964.2	+ 2401.2
Turnips (roots)	+ 640.8	+ 4823.8	+ 4129.6

The second question was the comparison of ammonia sulphate with Chili saltpeter. The variations were the following:

	Barley.	Oats, Beets, and Potatoes.
1. No nitrogen manure	—	—
2. Weaker Chili, pounds per acre ..	110	176
3. " sulphate, " " ..	88	141
4. Mixed (2 and 3) half each	—	—
5. Stronger Chili, pounds per acre ..	176	440
6. " sulphate, " " ..	141	212

The following are the results:

I. Weaker Chili manuring produces much smaller increases than stronger. Barley grain, 207 and 366; barley straw and chaff, 188 and 459; oat grain, 559 and 763; oat straw and chaff, 956 and 1,403; potatoes, 2,401 and 4,912; beet root, 7,200 and 11,645 pounds per acre of increase respectively.

II. Weaker ammonia manuring has, with all the crops, as much effect as an equal quantity of nitrogen applied in the form of Chili.

III. No. 4 produced, with all the crops, the same effect as either No. 2 or No. 3.

IV. With cereals the results under heavy manuring (5 and 6) was the same whether with Chili or with sulphate. With roots the nitrate had the advantage; it brought out 1,312 pounds potatoes and 1,780 pounds beet to the acre in excess of what the strong ammonia did.

Professor Wagner's researches were conducted with plants in plots, which were moved on a barrow between the open air and a greenhouse. His results confirm those of Professor Marker, especially as regards the beneficial effect of lime in conjunction with sulphate. He concludes that, practically, equal weights of Chili saltpetre and of sulphate of ammonia produce the same effects, and that the advantage which Chili sometimes appears to have over an equal weight of sulphate is due to the absence of lime in the soil, and to the action of the soda on the plants.

OFFICIAL REPORT.—REVISED BY THE SECRETARY.—CONTINUED FROM
PAGE 286.]

TWENTIETH ANNUAL MEETING, NEW ENGLAND ASSOCIATION OF GAS ENGINEERS.

HELD AT YOUNG'S HOTEL, BOSTON, MASS., FEB. 19 and 20, 1890.

FIRST DAY—FEB. 19—MORNING SESSION.

Mr. Waldo A. Learned (Newton, Mass.) then read the following paper on—

REVIVIFICATION OF OXIDE OF IRON.

Numerous attempts have been made to revivify oxide of iron *in situ*. Air is introduced in the gas, which not only reduces the candle power, but causes heat and back pressure in the boxes. The loss of candle power may be very small in a gas heavily charged with hydrocarbons—the gas being made by a low heat; but in many works when the heats are high there would be an appreciable loss of candle power.

My experience with air was in July, 1887, when our purifiers ran six weeks without change, purifying 19,600 feet per bushel of oxide. The candle power was reduced and the deficiency made up with an enricher. The heat in the boxes induced me to increase the pressure on the retorts, when a change of purifiers was the result.

Oxygen is used in place of air with good results, provided your purifiers are large, the oxide of good quality and the coal carbonized very free from sulphur, or means taken to remove a large portion of the sulphureted hydrogen before it gets to the purifiers.

Another method has been to force air up through the material, the cover being removed or a special outlet provided. The heat of the steam, with the heat due to the chemical change, produces a high temperature, which causes fire and bursting of the boxes by expansion.

I wish to speak more particularly of the method we have adopted, and used for 28 months, of revivification in the boxes by drawing (not forcing) air through the material by the aid of a steam-jet exhauster. The exhauster is made of a 3-inch to 2 inch cast iron reducer, with $\frac{1}{2}$ -inch steam injection pipe, tapered at the end. Connection is made with the inlet of the purifiers by 3-inch pipe. The outlet pipe of exhauster extends through the roof of building.

The purifiers (12 × 16) are in series, with a dry center seal. The material used is Irish bog ore, a natural oxide of iron, purifying 3,500 feet per bushel; also, a prepared oxide, commonly known as sponge, purifying 4,500 feet per bushel. This sponge, which is made at our works, consists of 15 lbs. iron filings, 10 lbs. sal ammoniac and 1 lb. copperas to a bushel of coarse sawdust. The shavings are wetted with a solution of silicate of soda and water to make them less combustible.

It is a well known fact that when the oxide takes up sulphureted hydrogen from the gas, there is a liberation of a quantity of water which the shavings probably absorb. When revivification takes place about one half the quantity of water is taken up. The moisture must come from the air or the shavings, and a number of reactions may wash off the solution. However, for practical working with new material, there is a decided advantage by its use. It is not essential to use copperas, which is sulphate of iron, and it acts simultaneously on ammonia and sulphureted hydrogen. My method of working is such that it leads me to use it in the mixture.

Coke breeze is used on the bottom layer of purifiers, then 18 inches of oxide of iron and 3 inches of lime on top layer. The object of the lime is to take out carbonic acid. I cannot agree with some of my friends that it is cheaper to enrich the gas than it is to use lime to make up the loss of candle power due to the presence of carbonic acid in the gas. When the material in the box is foul, the cover is taken off, the lime removed, the steam jet exhauster started on two tenths vacuum, which varies with the density of your material, and in from four to six hours it is thoroughly revivified.

The oxide is then turned over in the box to maintain its porosity, as after each revivification the material becomes more dense and the trouble would be back pressure. With the sponge this operation would not be necessary on account of the lightness of the material.

Heat is the greatest impediment in the way of successful revivification. Our first attempts were made with fear and caution. Steam was then used to aid revivification by its moisture, and to reduce the temperature in the material. The steam heat and the heat due to revivification caused too high temperature for successful working. This led to the introduction of water forced over the bottom of the purifying boxes—the object being to reduce the temperature, which was successfully accomplished.

The highest temperature recorded in the foul material in the state of revivification was 225° Fahr. It should not be above boiling point, as

sulphur melts at 235°, when the porosity of the mass would be affected. We have no definite knowledge of the chemical changes that take place in the purifiers, which vary with the quality of coal and conditions of the gas; but we do know that with iron purification, the sulphur compounds are more erratic in their behavior than with lime purification. A box will show sulphureted hydrogen one day, clean the next, followed by foul indication on the third day. It has been stated that this sudden change is due to bisulphide of carbon—it has no chemical combination with oxide of iron as it has with lime, but seems to be mechanically bound on free sulphur. A sudden change of temperature and pressure will throw this impurity off in the gas.

With lime purification we have noticed this rise of sulphur, when our custom of changing purifiers was to allow the third box to do some of the work after the second showed sulphureted hydrogen, the object being to allow the second box to act on bisulphide of carbon the contents being foul. It was only until then in proper condition to act upon this impurity—the first box removing carbonic acid, the second bisulphide of carbon, and the third sulphureted hydrogen; but when the second box receives an access of sulphureted hydrogen, or when carbonic acid comes over from the first box, the conditions change and contents of the second box become useless.

Discussion.

The President—You have heard a very interesting paper. I think Mr. Neal, of Charlestown, has adopted a similar plan; we would be glad to hear from him.

Mr. Neal—I attempted it, then for a time ceased the attempt, only to attempt it again. The first attempt was made with Mr. Shiras, who came to see me about it. He recommended revivifying by injecting steam. I did it splendidly, setting fire to the trays, burning them all up, and making a most intolerable smell, which was a nuisance all round. I think we ran very great risk. That plan was abandoned, and I did not again venture to revivify with lime in the purifiers for a long time. I have used oxide of iron, or iron sponge which I procured from the Connelly's with moderate success. Of late years and for some time past my Superintendent has manufactured the oxide of iron, using pretty much the same materials and the same mixtures used by Mr. Learned. Sometimes I have purified 18,000 feet to the bushel, and sometimes 2,000. It varies very markedly. The sulphur content varies sometimes, from 6 or 8 to 16 or 17 grains. We are using Westmoreland coal. We have for some time past used a steam-jet exhauster similar to that described by Mr. Learned. We remove the cover and let on the steam, and that draws the air through the mixture. For a while, even with the use of air in that way, the boxes became very much heated. I abandoned the use of steam, or at least of air, and then I commenced again. The trouble is when the oxide of iron is first made it is very "sharp," and heats very readily. Then, after awhile, finding that the heat was so great, we would revivify for awhile by drawing through the air to take out nearly all the sulphur, revivifying it very nearly. Our practice is now, after about 4 hours, to take the mixture entirely out of the boxes and place it on the floor of the adjoining shed prepared for that purpose, where it is turned and wetted thoroughly, and then put it back. I asked my Superintendent if that was not unnecessary work. He said it cakes on the bottom of the trays so that it makes a back pressure; therefore it is removed and then placed right back. We find that if we leave it in the boxes to revivify it will heat very badly. I must say that our purifiers, for our manufacture, are rather small, and require to be changed quite often—perhaps the purifiers do not do the work that they ought to do, because we manufacture water gas. I would say, by-the-way, that the coal gas and the water gas are mixed just before the gases reach the purifiers, where they come in with a tremendous rush, and I have found it necessary to prevent the blowing out of the seals of the purifiers, which were rather low, to use a jet exhauster to draw the gas through after passing the meter. This jet exhauster stands between the meter and the gas holder, and it works admirably. We can set it so that the pressure on the purifiers will be almost nothing, or at 2 or 3 inches. By that means I can make water gas, with light seals and small purifiers, to a very great advantage. In speaking of our process of purification, I will say I use a layer of sawdust on the bottom tray, and then place over it cloth or bagging to keep the oxide from mixing with the sawdust. Of course, the sawdust will last for quite a long time. I do not use the shavings which Mr. Learned speaks of.

Mr. Learned—I use breeze instead of shavings.

Mr. Neal—I use as coarse sawdust as I can get, from pine wood, not from hard wood. I am very well satisfied with my present method, but would like it better were it not that we have to change the mixture on the trays.

Mr. Jones—I would like to ask Mr. Neal how any saving is effected.

seeing he continues to remove the oxide from the boxes, and spends money in the removing and handling of the material.

Mr. Neal—I can save something, because the boxes are so small that our purifiers are changed very often. If we remove the mixture we have to turn it over and over, and it does not revivify near so fast—not fast enough for practical use.

Mr. Stedman—You spoke of the oxide heating after it has been returned to the box. Do you mean before the cover has been put on?

Mr. Neal—It would heat after we put it back. It heats after revivifying, if we leave it in the boxes.

Mr. Stedman—I became interested some months ago in brother Neal's success, and got his formula and commenced trying some experiments myself. My object was to get as much iron in the purifier as possible with a given bulk of sawdust. We found that we could use 3,000 pounds of iron with 100 bushels of sawdust, but beyond that point it had a tendency to cake up too much, even when it was first oxidized. We tried various systems of revivification, with the usual result of getting afire now and then; but we watched it pretty closely, and it did not burn out anything more than a small hole each time through the trays. It occurred to me that if we could send air enough through the oxide in a given time we could control the matter of temperature to a great degree. At one of the abandoned gas works we had a large blower and a little engine, which we transferred to our other works and are now using it experimentally. We found that we could always control the matter of temperature, when there was a disposition for the oxide to get too hot, by sending an extra current of air through. The ignition does not follow as it would when you start a fire in the woodpile, and where, when you give it more air, you encourage the flame; for, of course, the result of the heat from oxidation is quite gradual, and, if it can be carried off at any time by means of a good, fierce blast of air, the temperature can always be kept low. We find it rather desirable to encourage high temperatures to facilitate oxidation. In sending through a large blast of air, we found that the oxide was unduly dried, and required moistening again to make it immediately effective when the gas was turned on. We, therefore, adopted the plan of turning the exhaust right into the inlet pipe of the purifier. We have a wet center seal, and by cutting a hole in the top, over the dead part of the seal, and connecting the exhaust there, we have the connection made at the right place every time. When the purifier cover is lifted, we put the blower on for a few moments with a very rapid blast of air, and blow the gas out which is in the purifier, and then run a slower blast, watching it pretty closely at first, until we have ascertained that the temperature is not going up, and still that we have not got an excess of air in there to keep the temperature down too low. With that method of working we have been quite successful. The oxide does not cake; we do not have to turn it over; and we should not have to take it out of the boxes at all were it not for the fact that our scrubbing facilities are too small for the additional work which has been thrown upon them by the consolidation of all the work there in one place; and consequently considerable tar gets into the purifier. We arrest that by a pretty thick layer of breeze on the lower tier, and we find that the breeze gets saturated in about every third or fourth time coming around to that box. We then take out the oxide, renew the breeze, put the oxide back again, and it is already to work again.

Mr. Neal—I might say with regard to the ammonia, that perhaps our method of revivifying, or rather of purification by the use of the oxide, answers the purpose of a washer or scrubber. Our washer is not as effective as it ought to be, and the gas comes in containing say 100 grains of ammonia to 1,000 feet; but when it comes out, by the State Inspector's test, it never is over one per cent. Of course it is working the purifiers very hard, and I would like to put more work on the scrubbers.

Mr. W. A. Wood—I did not quite understand Mr. Stedman's operation. Does he force the air up through the sponge into the inlet pipe?

Mr. Stedman—Yes.

Mr. W. A. Wood—You might draw back on the inlet pipe and pull it through. By exhausting from above downward, the heat of course starting at the bottom, the lower trays can be taken away more easily.

Mr. Stedman—I supposed that the heat was where the air would come in contact with it first.

Mr. W. A. Wood—It seems to work the other way. If you heat at the bottom, and take that heated layer away before it has time to fire the sponge, there is no danger of fire. I have run in that way for three months without taking the material out of the boxes. We did have some fires when we first attempted it, but we manage it now so that two men practically do all the work in our purifiers; and we were obliged to change the boxes nearly every day. It is a very great labor saving to us.

Mr. Allyn—About how long does Mr. Wood carry on this operation?

Mr. W. A. Wood—From four to six hours. I will say that I do not think the revivification is as thorough as when the sponge is taken out and turned over.

Mr. Allyn—Do you detect more back pressure?

Mr. W. A. Wood—The sponge does cake with us after we have revivified four or five times. Our method then, is to take out the oxide at the bottom of the box and throw it up on top, and put the loose material which has not caked down on the trays again. By turning it right in the box itself we get rid of the trouble from that pressure in a short time. I like that method by reason of the fact, if you are obliged to change the purifiers, on account of back pressure, you can get a fresh one in a very short time.

Mr. Allyn—I think Colonel Stedman is right in his supposition, that if the gentleman would allow more air to enter the purifier there would be less danger of generating heat. When I was at the Brookline works, complaint was made on account of the odor which escaped when the lime purifiers were being emptied, so to overcome the nuisance, I put on an apparatus similar to what Mr. Learned is using, and on the first experiment we merely removed the substance through the corner of the purifiers. In 15 minutes it generated so much heat that it was impossible to put a hand on the purifier. After that, we raised the cover enough to just unseal the edge of it, and then had no more difficulty—the purifier never heated at all.

Mr. C. S. Spaulding—We use that same apparatus to-day for revivifying our sponge. We use it as has been mentioned, drawing the air down through and taking the cover of the pan entirely off. We are troubled with heat, and have had fires, but not to amount to much. We leave it in the pans three or four times before taking it out. Every third or fourth time we take it out and put other sponge in, and let that stand out in the yard for revivifying. We find it a great success and a great labor saver.

Mr. Jones—I would like to ask Mr. Learned how much it costs for steam to revivify one box with the arrangement that he has at present?

Mr. Learned—I cannot tell. We have about 60 pounds of steam—a half-inch valve—and we open it about a turn and a half.

Mr. Prichard—I find that about 40 cents of steam replaces about \$2 worth of labor.

On motion of Mr. Jones, a vote of thanks was tendered to Mr. Learned.

Mr. N. W. Gifford, of New Bedford, Mass., here read his paper, entitled:

SOME EXPERIMENTS IN THE PHOTOMETER ROOM.

In the introduction to a work on chemistry published in the year 1758, the author remarked something like this: "There are four elements, viz.: Earth, air, fire, and water. There may be other elements, but as we cannot possibly perceive them by our senses, it is idle to vex our minds with vain conjectures concerning them, and experiments usually lead to disappointment." Had this man lived in our day and been acquainted with the science of photometry, he might have still held the same opinion of experimental research.

I suppose most gas men have known of cases where the photometer falls into bad repute by giving the candle power much lower than the Superintendent believes it to be. I have noticed that this does not often happen when the gas is unquestionably of good quality, but when one fears his gas may be perhaps a candle below the usual standard. Then sometimes the boy reports the candle power down to 15 or even 14. His report is not received with favor, and he is sent back to take the candle power again. He looks at the water line in the meter, finds the candle balance accurate, flames at proper distances from center, etc., but still the pointer refuses to move up the scale. So, what wonder if he consigns the whole science of photometry to the realms of darkness? But says one, "There must be some cause for this remarkable drop," and some of the experiments, which I am about to call your attention to, may suggest some of the causes that may help to bring about this low candle power.

The photometer on which this work was done is of the open type, 100-inch bar, in a room from which the daylight can be shut out. Walls, floor, and ceiling painted a dead black. Size 7 feet by 15 feet, and contains about 900 cubic feet of air space. It is so arranged that gas or candles can be used on either or both ends. The standard of comparison used was a Methven slit. The burner was so arranged that the air supply to the light measured could be taken from a small holder at any rate desired, or could be left open as in the ordinary way. The following averages of several observations will show some of the effects of variations in the air supply, viz.:

Air supply open.....	gave	17.13	candles.
" " 51 cubic feet per hour,	"	15.22	"
" " 46 " " " "	"	15.97	"
" " 42 " " " "	"	17.10	"
" " 35.3 " " " "	"	17.82	"

Thus we see the normal amount of air used in burning 5 feet of gas was 42 cubic feet. When more air was forced through the burner, the light was reduced, and when the air supply was checked the candle power increased, until with less than 35 cubic feet per hour the flame began to smoke. An analysis of the gas showed that 28.19 cubic feet of air was required for the combustion of 5 feet of the gas. So that in the normal condition of things 13.81 cubic feet of surplus air passed through the burner, and, when checked to give the greatest amount of light, there was a surplus of 7.11 cubic feet of air.

So it appears that more air than a certain surplus passing through the burner tends to reduce the light. This reduction is probably largely due to the cooling effect of the aqueous vapor in the air, for when the air supply was passed through a desiccator, the loss suffered was not so great. For instance, the burner supplied with 38.1 cubic feet of dried air per hour gave a light of 18.34 candles, while with the same amount of undried air the candle power dropped to 17.38 candles, a loss of over 5 per cent.

As the volume of air passing through the burner depends on the size of the opening, height of chimney, and amount of heat inside the chimney, it can readily be seen that as the flame decreases, either on account of smaller quantity or a poorer quality of gas, the volume of air coming to it will not decrease in the same ratio. A 16.75 candle gas used 44.2 cubic feet of air per hour, and a 15.62 candle gas used 42.2 cubic feet, but the surplus above what was required for theoretical combustion, as shown by analysis, was almost the same in both cases, a difference of less than one-tenth of a cubic foot. So the weaker flame had as much unnecessary cooling to contend against as the stronger.

Now this disadvantage under which the poorer gas is burned can be overcome to a certain extent by altering the chimney, or by increasing the quantity of the gas to make up for the deficiency in quality. As an example of the first method, I give the following tests with chimneys of lengths ranging from 6 inches to 7½ inches, but of uniform diameter:

With a 6 inch chimney the light was	17.64	candles.
" 6½ " " " "	17.34	"
" 6¾ " " " "	17.17	"
" 7 " " " "	16.82	"
" 7 " " " "	16.40	"
" 7½ " " " "	16.37	"

Here we find a decrease of light from the flame as the length of the chimney is increased, amounting in all to a variation of 7.7 per cent. from the result with the ordinary 7-inch chimney.

To show the effect of increasing the gas consumption, I give the averages of a number of tests in which the rate of burning varied from 10 per cent. below to 10 per cent. above the normal rate.

Gas burning 4-5 feet indicated c. p.	12.19.	Corrected	13.4.
" " 4.75 " " "	14.72.	"	15.85.
" " 5 " " "	15.82.		
" " 5.25 " " "	16.88.	"	16.03.
" " 5.5 " " "	18.29.	"	16.46.

In the last instance, increasing the gas consumption to bring the readings up to 18.29 candles gave a value of 16.46 candles to the gas after being corrected for the increased volume, which amounts to a gain of 64 candles, or 4 per cent. over the candle power found when only 5 feet per hour was burned. In consideration of these facts, would it not be simple justice to the gas, on these occasions of reported low candle power, to increase the rate of burning until the readings are brought up to about the usual figure, and then calculate the result back to a basis of 5 cubic feet per hour?

In connection with this subject of air supply, I have some figures which emphasize the necessity of thorough ventilation for the photometer room. I placed a Sugg burner at each end of the bar and took a series of readings, which showed the light from each to be alike. The room was closed for 2½ hours, when on supplying one of the burners with air from the prover, it was found to give 10.9 per cent. more light than the one taking its air from the room. Again, a burner supplied with 34 feet of air per hour gave a light of 17.77 candles, and on being supplied with the same amount of air having 5 per cent. of oxygen added to it, gave a light of 21.52 candles, or an increase of over 20 per cent.

Discussion.

The President—Have you any questions to ask with regard to those experiments? It is a simple type of experiment which may help some of us out of some of the difficulties which we have all experienced in the photometer room. Has anyone had similar experiences to state, or any questions to ask?

Mr. Humphreys—I would like to ask Mr. Gifford how, in his first set of experiments, he supplied the air to the burner?

Mr. Gifford—I will say that to an ordinary Sugg burner I made a connection through a paper tube large enough to slip up above, so as to go outside of the burner; and while it was not a neat mechanical job, I made it air tight by adhesive double tape. The bottom of the paper tube I connected with iron piping to the meter-prover.

Mr. Harbison—I think Mr. Goodwin, of Philadelphia, can give as much information on that subject as all the rest of the fraternity.

The President—We would be glad to hear from Mr. Goodwin at any time.

Mr. Goodwin—I can simply say that several years ago, from very similar tests, I can verify the statement made by Mr. Gifford. I practically did the same thing in my photometer room, and with practically the same results.

The President—Do I understand it is your opinion that we are to gauge our chimneys in order to limit the air supplied to the burner? Would it be advantageous to have the gas interest determine the size of chimney which should be used with a certain burner?

Mr. Goodwin—The size of chimney which you use makes all the difference in the world as to the illuminating power which you get from a given quantity of gas through a given burner. If the chimney is six, seven, or eight inches long, the difference in height will make all the difference in the world.

The President—Then each burner requires a certain chimney?

Mr. Goodwin—I mean to say that by varying the chimney on a five-foot burner, you get very different results as to the illuminating power, just as Mr. Gifford has stated. I suppose I have made 20 photometers in the past year, and have had ample opportunity for arriving at correct results. Several years ago I made some tests in the same direction, and I can verify Mr. Gifford's statement.

Mr. Coggs—Then you would say that, using 17-candle gas, you would require a 6 inch chimney rather than a 7, according to his results?

Mr. Goodwin—I would not like to say that that would be the size of chimney, but I do say that the chimney has all to do with it as to the illuminating power.

The President—I think these experiments are in the right direction, and will go further as we find the necessity existing because of competition with the electric light.

On motion of Mr. Jones, a vote of thanks was tendered to Mr. Gifford. A recess was then taken until 2:30 P. M.

FIRST DAY—AFTERNOON SESSION.

The afternoon session was opened with the paper, by E. G. Pratt, of Des Moines, Iowa, entitled:

DIFFERENCE IN THE EASTERN AND WESTERN METHODS OF MANAGEMENT OF GAS WORKS.

[In the absence of the author, the paper was read by the Secretary.]

I appreciate the honor of having been called upon to contribute something to the success of this meeting, and while I have regretted many times that I so readily gave my consent to write upon the subject suggested, and had, owing to the pressure of business, almost made up my mind that I would ask to be excused—in fact, was in the act of writing for that purpose—when, in looking through the AMERICAN GAS LIGHT JOURNAL, I noticed that the editor, in commenting upon what might be expected at the coming meeting of this Association, for some reason or other, I know not why, laid considerable stress upon what might be expected from the papers to be furnished by the gentleman from Dedham, and myself. He, however, very adroitly warned the members that the quality of the reading might be only in the title, or cover, which I am very sure will be the case with what I shall have to say; hence I hope that neither he nor any of the members has anticipated too much, for with the very short time now at my disposal I shall not attempt to approach the dignity of a paper, but rather let this pass as a letter to the Association. I did think, when the subject was first mentioned, that it would be an easy matter to write up something interesting—and there was certainly an opportunity of saying a good deal; but, upon a serious second thought, and when I got right down to business, I found there was not so much in it after all—at least unless the one who attempts to speak has confidence that he is perfectly familiar with the affairs and conditions of things as they exist in the East compared with that of the West. It would be generalizing too much for me to make a statement that what has been my experience or observation in the East, while in charge there of the affairs of a small gas works, would apply to that of another in charge of a larger works; or to submit what has since been my experience and observation while living in the West, in charge of the

affairs of a larger concern, was applicable to those of the same size or larger, and I am fearful, too, that I might say something that would invite criticism, or that some member would take exception too. I trust, however, that in giving expression to my observations there will be nothing said to reflect upon either locality; for, certainly, that is not my intention.

It is a pleasant thing, and I am sure New England gas men appreciate it, to be so situated where, because communication is easy, that they do not have to depend entirely upon these annual gatherings for an exchange of greeting and ideas (for probably not a week passes but that you can count upon meeting some gas man eager for information, or willing to impart it, upon some particular point), while we in the West (and I speak as if I had always lived here), are more or less dependent upon the technical papers for what is going on; or, in an emergency, have to rely entirely upon ourselves, or those at our command. This same sentiment I think will bear me out in what I have to say. Take it in the matter of supplies. You of New England can, on twelve hours' notice, get anything you are in need of, not excepting even coal and pipe; and the cost of getting it is immaterial as compared with what, under similar circumstances, it would be here in the West. It is necessary, therefore, for us of the West, to so anticipate all our needs that we can buy in such quantities and at such times that the expense of getting them will be the least, and that they will be on hand at the time when needed most. While it is true that the handling of freight has been greatly improved, still, at its best, it is very slow and often times very unsatisfactory, particularly for such goods as we may be looking for from a distance. If we resort to express, as frequently we are obliged to, the expense thereof adds very largely to the cost of the article. I mention this important factor of transportation to show that the gas man of the West is obliged to take more thought of the morrow than his brother of the East; and hence is cultivating that essential known as "long-headedness," which, by-the-way, is very important in this part of the country, and concerning which I may have more to say later on.

In the matter of labor, I believe it to be true that we pay more here than in the East—not that the cost of living is more, or that the demand for labor is greater, for I do not think there is much difference; but there seems to be an independence innate with the locality that demands more. And, too, the Western laborer is more liberal in his expenditures than his fellow laborer of the East. He takes more recreation, and has more enjoyment of this world's goods. It is also a fact that the average Westerner is wasteful, which habit, I am sorry to say, is sometimes prevalent about a gas works, and it very often disturbs the peace of mind of one brought up in thrifty New England. Then, again, not so much attention has been given to the general condition and appearance of things about the works; for what reason I know not, except it be that false idea of economy that it were better to run a thing for all it was worth and make the repairs only when those became actually necessary, or when the profits would admit. For such a condition of things I believe the management to be directly responsible, and that by proper discipline it could be obviated. The New England gas manager, as a general thing, takes pride in keeping his works in such condition that they will pass inspection at any or all times; and I believe he does this at no greater expense in the end.

I have referred briefly to some of the inconveniences under which the Western manager labors, whereby his operating expenses are in excess of yours in the East; and were it not for the fact that these were to a great degree offset, we would not be able to sell gas as cheaply here as at present is the case. In looking through the directory and noting the price of gas at seven of the largest cities in the New England and Middle States I find that the average gross cost is \$1.44 per 1,000 cubic feet, while in seven of the largest of the Western cities the average gross charge is \$1.46 per 1,000. Just how to explain this I do not know. If all the companies considered were making coal gas, I should say it was because of the value of residuals in the West, as the price we get for them is in excess of what they bring you in the East. We have a market for all our coke and tar, and while the price of the former depends upon the price of hard coal, the demand for the latter is such that we have no difficulty in disposing of our entire output at good prices.

As is well known, however, many of the larger works in both sections of the country have equipped themselves, or are about doing so, with a water gas plant, either because they believe they can make water gas more cheaply, or because no gas works is now considered complete without them, all of which no doubt lessens the supply of these residuals, and so increases the value of what is left, because the demand, at least, remains the same.

There is an advantage, too, that many of us favorably located in the

West have, in being able to use the cheap coals mined throughout this section of the country, which, if not suitable for gas yielding, are certainly very helpful and economical for fuel purposes; and, on account of their cheapness, many of us are enabled to sell our entire output of coke by using these cheap coals under our boilers and in our furnaces that have been specially adapted for the purpose. At some of the Western works they are able to use a large percentage of these native coals for gas making; and mixed with Youghiogeny, Penn, or Westmoreland, get very satisfactory results, both as to yields and candle power.

In the matter of main laying, we have an advantage, inasmuch as the expense of laying pipe here is, on account of the condition of the soil, not so great, even though in some instances we lay our pipes deeper. It may be said, however, that we lay more of it, and that the immediate consumption is not so great to the mile as in the East. This may be explained from the fact that Western towns and cities grow more rapidly, and that to keep up with the prospective growth we are obliged to keep in advance of city improvements, such as sewerage, paving, etc., that all come at once. We frequently lay pipe in a street or locality that to an Eastern man would seem like madness; or as it did to me until I had become somewhat accustomed to the growth of these Western cities. Then, again, much of our pipe was laid originally with little attention as to width of streets, grades, etc., and later on, when these city improvements materialize, we are annoyed with the expense and difficulties incident to straightening, lowering or raising our mains. Many of us, too, are troubled with excessive leakage, which cannot be improved upon until we have instituted a thorough and systematic means of stopping it. The prime cause of all this is probably owing to the fact of the pipe having been originally laid by some contractor who did not consider it important that the joints be made tight, so long as the required weight of lead and yarn was used. These thoughts suggest a whole chapter of difficulties; but of which I will not speak, least I say too much that would be of little importance or interest to you.

In regard to the consumer, I may say he is just as fond of finding fault here as elsewhere, and cannot understand why his bill should be larger in December than it was in July, or that the price should be any in excess of what it is in cities or towns selling more, or that are more favorably located. Naturally he takes gas to be gas, whether here or in the coal fields of Pennsylvania; that is, he assumes it to be his honest belief. He is alive to all new processes, and whenever he reads that some man or woman has invented a process by which gas can be made for 5 cents per 1,000 cubic feet, he is anxious to know why the local company does not adopt such process and give the public the benefit of it. If a deaf ear is turned to his suggestions, then he is in for organizing a company that will adopt the "new ideas," and very frequently finds plenty who interest themselves with him, until after investigation he or they find that it is a myth. Nothing daunted, however, he is always ready for any new process that may present itself, never for a moment stopping to think that we in the business are alert to any new thing; and, if it can be shown to be an improvement over or in addition to what we have, are ready to adopt it and to give our consumers the benefit of it.

It seems to me there are more schemers, or those who live by their wits, in this western country than east; and as franchises are easily acquired, one must keep on the alert all the time, and even sleep "with one eye open," to protect those interests that have been placed in his keeping. The people, however, in communities where this thing has been practiced, noting the repeated failures of these schemes and schemers, are beginning to understand the real status of the case and decide that the local company is not made up of such short-sighted and close-fisted set of fellows as they were at first made to believe.

It is discouraging sometimes to think that the propositions of these people even find audience, when it is considered how attentively we look after the interests of our consumer; but it is to be presumed that human nature is alike in this thing as in many others, and the willingness on our part is usually taken advantage of.

People of the West are fully alive to any new method of lighting, and will be satisfied with nothing but the best. The electric light is cutting quite as important a figure here as elsewhere, and in the smaller towns has materially affected and seriously injured the business of the local gas companies, unless they were far-sighted enough to equip themselves with an electric plant to meet the exigencies, and thus keep out the opposition that is sure to establish itself. While in most of the larger cities the sales of gas continue to increase, still many of these have or are contemplating the necessary plant to supply either kind of light, for they do not believe they can afford to turn away a customer that would patronize them because they did not have the kind of light he had made up his mind would best suit his purposes.

The combination of these two interests greatly increases the responsibility of the manager, and he finds that he must not only keep himself posted in all that pertains to gas, but electricity as well.

In conclusion, I desire to express my gratitude to the Directors of this Association in remembering me and in requesting that I contribute a paper. If in what I have said there may be any good or interest derived, then I shall have been amply repaid.

The paper was not discussed, and, on motion of Mr. Slater, the thanks of the Association were voted to Mr. Pratt.

Mr. A. B. Slater, of Providence, R. I., then read his paper, entitled

WHY I SHALL MAKE WATER GAS.

About the 10th of January I received from our gentlemanly Secretary a note, in language so dignified, so courteously entreating, so earnest, and at the same time so pathetic, that I was left no alternative, no option, but at once I felt impelled to accede to his request and prepare a paper for this meeting which, if it contains nothing new or instructive, may at least serve to amuse you for a few moments. He did not assume the responsibility of selecting the subject, but placed it upon "some one of the Directors," who had suggested as a subject for me to write upon, "Why you went into water gas."

Of course I have no knowledge, or even the least intimation, who this Director is; but, whoever he is, he must be a man of courage, and I ought to be a man of still greater courage to come before this old orthodox New England Association of Gas Engineers with a subject about which so much has been written and said, and which has occasioned so much, may I say bitter, controversy between its promoters and the older gas engineers and managers as this same subject, water gas. To attempt to go over this long controverted ground, and direct your attention to the feelings of hostility and even bitterness engendered by the early introduction of water gas, and the persistent energy displayed by its promoters in experimenting and perfecting apparatus which would overcome the difficulties and troubles encountered for many years upon its first attempted introduction upon a practical scale, would be to write a volume. To the older members of the Association this is all quite familiar, and the younger members can spend their time more profitably in studying the conditions of things as they exist to-day.

I will say, however, in passing, that in my judgment the feelings to which I referred, of opposition to water gas, etc., etc., were not engendered so much by the gas, or its composition *per se*, as by the aggressiveness displayed by its early patentees and advocates in forcing its introduction by questionable methods, even before it had reached its present perfected state, which is almost wholly due to improved apparatus for its manufacture. The objection to carbonic oxide by and of itself is just as forcible in principle and theory to day as at its first introduction. By itself it is just as virulent a poison now as then; but then no gas company does or purposes to send out to consumers carbonic oxide alone, and I am not aware that carbonic oxide has ever been recommended for breathing purposes; but as one of the component parts of the finished gas it really is of advantage, as it produces a high flame temperature, and consequently more perfect combustion than straight coal gas does; and when we come to look at it and carefully consider the facts as they now exist, the question of carbonic oxide practically drops out of sight.

You say at once, "Why?" My answer is, simply from the fact that with the exception, I think, of but two States of this great country, the State and municipal authorities without opposition permit water gas to be made and distributed to consumers.

When we know that by far the larger portion of the gas made and distributed in most of the larger cities of this country is water gas, and with practically no objection on the part of the public, the question is at once reduced to the simple matter of dollars and cents; and the sooner we recognize this fact the sooner we will place ourselves in a condition to take whatever advantage there may be in location, prices of material and labor, cost of construction, or any other conditions which can be secured by its adoption.

The question of quantity and quality of light given by water gas is no longer a mooted one. Again, if compared with the dangerous electric current, which you can neither see nor smell, the question of carbonic oxide, when considered in connection with illuminating gas, is really eliminated. But if applied to the distribution of so-called fuel gas, containing 45 per cent. of carbonic oxide and almost odorless, the old objection is at once revived in all its earnestness. With all the attending dangers, people will take electric light, natural gas, and what is least dangerous of all—and then mostly through gross carelessness—water gas.

The question of the disposal of the residuals (especially coke and tar)

of a large coal gas works is one which occupies a prominent place in the consideration of the policy of adopting water gas, either wholly or in part, as on the net receipts for residuals the net cost of coal gas very largely depends. When a company is so situated as to be able, profitably, to make water gas instead of coal gas, it relieves the manager or superintendent from the labor, care, annoyance, and trouble of the disposal of residuals, which matter is quite a burden in a large coal gas works. The question of the cost per thousand feet to manufacture coal gas or water gas depends almost wholly on the relative prices of gas coal, enriching materials—such as cannel coal, crude oil, naphtha, etc.; cost of material used in generators, prices at which residuals can be readily disposed of, prices paid for labor, etc., etc.

As applied to the company which I have the honor to represent, I recommended the adoption of water gas as an auxiliary to our coal gas plant, for several reasons, among which are: First, based upon present prices, a material saving in the first cost of the gas; second, by combining the two systems, we can make a small saving in the cost of our coal gas, because we can run our coal gas plant more economically; that is to say, we can keep fired and use continuously, without missing charges, such number of benches and keep employed such number of men as we can keep at work to the best advantage, and make up any excessive variations in the demand for gas, with the water gas plant; third, we shall make less coke to be disposed of, and at the same time be our own customer for a considerable portion of what we do make, thus effecting a saving on that residual; fourth, we shall make less tar, which we have not been able to dispose of at remunerative prices; but the lessened quantity will net us about as much in the future as we have heretofore received for the whole. The large quantity of water gas now made in our large cities has very materially diminished the quantity of tar heretofore made, so that the price of this residual is already being considerably advanced. Fifth, the question of labor is an important one which enters into the consideration of this question. A good water gas plant can be operated successfully with one-quarter to one-third the labor that is necessary in a coal gas works. This reduces the risk and annoyance consequent upon strikes or trouble with the men employed; and, finally, we intend to keep our coal gas plants up to the times as far as practicable, and with the addition of a respectable sized water gas works of the latest design and construction we are in a position to secure all the advantages of both systems, either alone or together, according as the price of material and other items of cost may seem to make it advantageous to do so.

The President—I think that before proceeding with the discussion of this paper we will listen to the paper on a kindred subject, by Mr. F. H. Parker, of Burlington, Vt., and then the two papers may be discussed together. In the absence of Mr. Parker, the paper was read by Mr. W. A. Wood. The paper bore the heading—

A FEW OF THE ADVANTAGES OF WATER GAS OVER COAL GAS FOR SMALL WORKS.

The works of the Gas Light Company at Burlington, Vt., were built in 1853, and were run as coal gas works until 1880. At the time the writer took charge (Jan. 1, 1877) the retort house contained four benches of 5's and one bench of 3's, that had been erected with new arches, hydraulic main, exhauster, condenser, etc., in 1874, and were probably at that time as complete works of their size as could be found in New England. Westmoreland coal was used, costing, delivered at the works, \$5.70 per gross ton. The best average yield obtained had been 4.77 feet per pound, and gas was sold at a net price of \$4 to \$4.28 per 1,000.

It is, perhaps, superfluous to remark that the consumers were not satisfied with the price of gas, and as the stockholders were unwilling that dividends should be cut down, a change of some kind was demanded. Quite a supply of tar had accumulated, and it was used as fuel under the retorts. The average yield of gas increased to 4.86 per pound. Some more coke was sold, and the net price of gas was reduced to \$3 and \$3.60 per 1,000, in the hope that the consumption might be increased. The effect was quite the reverse; for this reduction apparently served to remind consumers that they had been paying a high price for gas, and stimulated them to economize in its use, and the annual sendout decreased. As there seemed to be no further economies available towards cheapening coal gas, the Lowe process was adopted, is still in use, and the price of gas has been gradually reduced, the present net price being \$1.60 to \$2.25 per 1,000, and the amount of gas sent out last year was 10,000,000 cubic feet.

Having had rather an intimate experience with coal gas for 3 years and with water gas for 10 years, the following comparisons suggest themselves.

Among the disadvantages connected with the manufacture of coal gas

I recall to memory the very interesting experience with naphthaline; the abundance of limpid tar and tar that was not limpid, the piles of coke for which there was no sale when you wanted to get rid of it, and for which there was such a remarkable demand when you had none to spare; the interesting spectacle of stopped stand-pipes and of retorts with holes in their sides or too much carbon in their interiors, that collapsed just before you were ready to let them down, and had to be replaced at large expense; the services that always froze just as you were starting for supper; the drips that filled just when you could spare no one to pump them; the fires under the retorts that required careful attention night and day; the retort house and its inmates, never clean—the very thought of a strike, or a stoker drunk, sending chills all over you; and, in fact, a life of continuous anxiety and worry. But enough—many of you have been there, and are there now, but are doubtless praying for a brighter hereafter.

I allude, of course, to the experience of the superintendent of small works—one who, as friend Chase says, has the opportunity to become familiar with everything, from a Stillson wrench to a stock ledger; who, from the earnings, is expected to keep the plant in good repair, make all ordinary extensions and pay regular dividends, and yet sell gas at a price but slightly more than is obtained in the larger cities.

Those of you who do not recognize anything familiar in these reminiscences, and who have not been so fortunate as to be connected with a small works where the cold of winter equals that of northern New England, where you may expect 6 feet of frost every winter, little realize the joys you have missed.

On the other hand, with water gas naphthaline is unknown; you make comparatively little tar; coke does not appear upon the premises; you have but one stand-pipe to stop up, and that you clean occasionally when it suits your convenience; retorts and their lids do not trouble you; hydraulic mains full of pitch exist only in memory; services seldom freeze; but very few drips require any attention; you require less help; you make gas at whatever time of the day or night it suits your convenience, due regard being paid to holder capacity; you can thus avoid making gas in the heat of the day in summer, or make once in two or three days as necessary, and have your help in the meantime for other work; you do not require a large stock of materials on hand; your repairs are insignificant and unfrequent, and an occasional coat of paint or whitewash keeps your generator room bright and clean; and upon one occasion a certain individual was seen running our apparatus while attired in a dress suit—yet that is not, strictly speaking, our regulation costume.

The very marked odor of carbureted water gas makes the detection of leaks easy. We have thus been able to stop some that with coal gas were for years unsuspected, and, therefore, to steadily reduce our leakage.

The numerous barrels of brine that were required to be pumped into the mains to keep them clear in winter, when coal gas was made, are no longer a familiar sight upon our streets; and yet I freely admit that whether coal gas or water gas is made, if all trouble from frost closing or breaking mains or services is to be avoided, it can only be obtained by protecting them or by placing them below frost.

We are enabled now to use experienced men from the works to put in services, lay mains and repair leaks, while, when making coal gas, they were so closely confined that we had to rely upon whoever could be secured, as we did not have sufficient work of the kind to warrant keeping any one regularly employed for that purpose.

The rapidity with which water gas is made enables us to send out double our holder capacity each day, if necessary. One man has frequently made, with a generator 5 by 10, outside, 70,000 cubic feet per day, and averaged last season 41,000 cubic feet per day for nine weeks, preferring to do the work alone, as he expressed it, rather than be bothered with green help.

In making these comparisons I don't wish to be understood as claiming any superior results obtained over others working similar processes. On the contrary, I should be much surprised if others, using more modern apparatus, or working under more favorable conditions, do not excel us. We labor under the disadvantage of having a small consumption, considering the extent of our mains, and a small average consumption per meter, as we have comparatively few manufactories.

Neither do I wish to be understood as conveying the impression that water gas works run themselves, or that the position of manager of even a small works is a sinecure. With us life is not always monotonous. Our dear public, like yours, is always demanding more for its money, and the days are very rare when opportunities are not presented to us of combining an abundant amount of practice with our theory.

Discussion.

The President—You have heard two papers, one written by the manager of a works producing 460 million cubic feet, and the other written by the manager of works producing 10 million feet, between which limits, with a single exception, I have no doubt that most of us come. I would like to have a good discussion of the subject. Mr. Prichard was an early advocate of water gas, and had one of the earliest plants. We would like to hear from him.

Mr. Prichard—We have used a water gas plant with considerable advantage, at times when we were working the retort house to its full capacity, and used that to make up the irregularities of consumption. For that purpose it has served us very well. But, in the matter of cheapness, at present prices it is a question which of the two it is better to use.

The President—Mr. Humphreys has been busy for a year putting in a water gas plant, and perhaps he can tell why he did it.

Mr. Humphreys—I put in a water gas plant because I am supplying gas in a mill city where our consumption is very variable. In very dark weather our consumption will increase 100,000 feet per day over a bright day; and to meet that varying demand with coal gas works is very difficult. It is necessary either to keep a number of extra retorts under fire, or to make up all deficiencies on bright days; and while the latter course will work well enough if you have but a couple of dark days in a week, it will not work if there are five or six of them following each other. Since I have been in Lawrence, before the water gas plant was put in, I have stood by the holders many a day when it seemed as if I grew ten years older in the almost impossible effort to keep the holders up. Then, again, I regard the water gas plant as a cheap means of increasing the candle power of gas. Our idea is to make a water gas of about 28 or 30 candles, and to use that for enriching without the aid of any cannel coal. We have done this, using part coal in our generators, and we are now reaching the point where we hope to do it by using coke alone. That is the point we are aiming for—to use our coke from the coal gas works in the water gas plant. With regard to the question of price, which Mr. Prichard refers to, I would like to ask him whether he uses crude oil. In our works that we have we use Lima crude oil; and with that oil I have no doubt that we can make a gas at a lower figure than we can by the coal gas process. I am inclined to think that Mr. Prichard has not used Lima crude oil.

Mr. Prichard—That is just exactly the point. I have one of the old style of Granger works, with shallow generator and single superheater, and it is impossible to use Lima oil without sending the vapors of the oil all over the town. It has caused considerable talk, and so we only use it (the Lima oil) when it is absolutely necessary. If we use naphtha we get along much better. The comparative prices of the two with us, where we have to team the oil to the works, is about 6 cents for naphtha as against 3 cents for oil. You can readily see that what would be economy at 3 cents for oil might carry the balance the other way at 6 cents.

Mr. Harbison—I would like to ask those gentlemen who have had experience in the use of water gas as an auxiliary to a coal gas plant, what change they are obliged to make in their coal gas plant, if any, in order to use water gas in connection with it, and whether they have to have an additional holder; and, if so, how they manage it. I would like them to answer these questions, so that the rest of us who may be considering the question of putting in a water gas plant as an auxiliary may understand what we have to introduce more than we now have.

Mr. Slater—As far as we are concerned, I may say we have made no changes, with the exception of making the connection direct from the generator to one of our holders, which is about 280,000 feet capacity. We go directly from the generator to that holder, and draw the gas from that by an exhauster, and send it through the purifiers of the coal gas works, the same as the other gas. There are no other changes.

Mr. Harbison—I would like to ask Mr. Slater if he knows what proportion of each gas produces the best illuminant?

Mr. Slater—We have not reached that point yet.

Mr. Anderson—I would like to ask the question, with relation to water gas, if there is anything very noticeable in relation to condensation taking place in the meters; and if the meters have to be re-diaphragmed any oftener because of burning water gas.

Mr. Prichard—We do not notice any difference, but I should suspect that if we kept on sending vapors of oil about the town we would have trouble from it.

Mr. Anderson—The reason I ask that question is this: In a room yesterday where meters are repaired I saw a number of meters in which there was considerable condensation. I made some inquiries, and found out that they had been used on water gas; and I was told that such meters had to be re-diaphragmed very often. There was one 250-light

meter there out of which was taken at least 5 gallons of a sort of resinous tar. I have a piece of one of the diaphragms, which is very brittle. The life of the leather is all gone, and for the purpose of examination I will leave it on the table.

Mr. F. H. Lane—I have been using water gas for several years, and I would like to get some facts, from those who have had experience in the matter, as regards condensation.

Mr. Shelton—I am in a particularly good position to know about the effect of water gas on meter condensation, from my connection with the United Gas Improvement Company, of Philadelphia. We have watched that point very closely, because it has been one of the points urged against water gas—that the life of the meter was shortened, that there was more condensation, and points of that nature. The whole thing in a nutshell is this. There is water gas and water gas. If water gas is properly made and thoroughly fixed you will have no trouble from that source. I grant that on some of the older forms of apparatus (one such is within a hundred miles of this city) you can take out a meter, disconnect it, turn it upside down, and get probably half a pint of the matter of which Mr. Anderson speaks. But I will make the prophecy that that apparatus was built ten years ago, has an extremely small superheater capacity, and is not in good shape to take care of the naphtha used, to say nothing of crude oil. The experience of our Company in the different works we operate is that we have to keep close watch on this point. We have compared the records of the drips on the streets, and also the meter reports, since water gas has been made with the back records when coal gas was made, and those statistics show that the effect upon the meters and upon condensation can be taken, to all practical intents and purposes, as just about the same, provided the gas is properly fixed and made with modern apparatus of fair efficiency. I do not mean the apparatus for making water gas of twelve years ago.

Mr. Jones—Mr. Slater in his paper remarked that there were but two States in the United States where prohibitory statutes relating to water gas are in force. May I ask to what State, other than Massachusetts, he referred?

Mr. Slater—I did not refer to them as prohibitory, but simply as States having a carbonic oxide law. I referred to Massachusetts and New Jersey.

Mr. Jones—In the State of New Jersey the law relating to carbonic oxide limits it to 2 per cent., which practically precludes the manufacture of any kind of gas.

Mr. Slater—That refers to new companies.

Mr. Jones—If that law were enforced to the letter it would preclude the use of cooking stoves in living apartments. I understand, with Mr. Slater, that that law refers to new companies organized since the passage of the law, ten years ago.

Mr. Humphreys—I want to say a word in answer to Mr. Harbison. He asked what changes were to be made at works when putting in a water gas plant. We happened to have a couple of small holders, of 20,000 feet capacity each, and we have used those as "relief" holders—making our gas into those holders, and then exhausting it back and putting it through the regular condensers and purifiers.

Mr. Cogshall—I would like to ask Mr. Humphreys what percentage of his whole product is water gas.

Mr. Humphreys—We are using about 12 per cent. of water gas now.

Mr. Harbison—Is Mr. Slater using naphtha or oil; and how many gallons per thousand feet of water gas made?

Mr. Slater—I use Lima oil, but I cannot state any definite quantity as yet. We are not running the water gas plant to its fullest capacity, but simply running it occasionally; and are using from 3½ to 4½ gallons.

Mr. Harbison—How does that agree with Mr. Humphreys' use of oil?

Mr. Humphreys—We are using about 5 gallons.

Mr. Stiness—I am glad to learn that the world moves. If a few years ago a man who occupies the position of my good friend Slater had spoken within the presence of this New England Association and told us why he made water gas, the very arch fiend of Sheol would have been considered pure and white in comparison. But I am very glad that he has given us such a very concise paper. It is in his usual strain, leaving no chance for argument. He argues the points himself. There are no criticisms to be made upon it. I move that a vote of thanks be tendered to Messrs. Slater and Parker for their papers.

Mr. W. H. White—May I be permitted, although a guest, to second that motion, and to say that I antedate brother Stiness; for I remember that (whether through the courtesy of the members of this Association, or through their fear of a double-edged tongue) I was the only man, for some years, who was permitted to speak of water gas in the New England Association without being immediately clubbed by the chair. It fills me with a great deal of pleasure to know that the road in which we

trod many years ago, then unmarked by the single footprint of a regular gas engineer, is now crowded, and that you are pushing one another over the edges of that road in your efforts to accomplish the good which I then foresaw. I most heartily second this motion, and most heartily welcome to the ranks in which I then stood, a lonely apostle, brother Slater.

The President—We are glad to welcome brother White, although he speaks of being a guest, as a participant in our discussions. I wish that every guest here would manifest the same interest that he has. I trust that all will join in the discussions without being individually asked to do so. We bid you all a welcome here in good earnest.

The thanks of the Association were then voted to Messrs. Slater and Parker for their papers.

Mr. H. A. Norton, of Boston, Mass., then read his paper on

VARIOUS METHODS OF INTRODUCING GAS STOVES.

Mr. President and Gentlemen of the Association: It was with reluctance that I accepted your Secretary's request to prepare a paper on a subject so near to me, knowing that you come to the convention to listen to gas engineers. Therefore, I have prepared this paper from material given me by members too modest to proclaim their own success in this direction. It is worthy of note that nearly every apparatus used in connection with the gas business has been remodeled or changed to suit the surroundings in which it has been placed, and to the gas engineer the credit of successful results must be given.

So it is and must be with the introduction of gas cooking stoves. No one rule can be given to bring about the desired result. The engineer should study his plans for introducing gas stoves as he would his plan of mains for distributing gas. The liberal policy pursued by most companies to-day makes the way towards acquainting their consumers with the merits of gas stoves easier. Where stoves are leased or sold below cost, the outlay of money used for that purpose should not be looked upon as too great for the return received that year, but as a permanent investment yearly bringing in a large interest.

They are consumers for life, and in a time and season when most appreciated. The different methods of introduction I shall speak of have accomplished their end to the satisfaction of those presenting them; and while there may be still better ways, let the introduction be not formal, but one that will surmount the barrier between gas companies and consumer, and make the latter feel that he was prejudiced in his supposition.

I speak, first, of leasing stoves; for that method is more popular with the majority. To lease any needed article on approval meets with favor; for the idea of a trial, at a fair investment on the principal, entices the most wary. Once let them take a gas stove as an experiment, then you have completed your task and have a willing captive. Of course, the desired result is to sell the stove, and this is, I think, the most successful method.

The companies leasing stoves charge, and readily receive about 25 per cent. on the price of the stove, all rentals being due the first of each May, thus making the matter of collections easy; and nearly all companies allow at least one year's rent to go towards the final payment when the sale is made.

The companies who sell their stoves outright allow the consumer a fair trial; and while it is a distinction without a difference I am sure, from my own experience, better results can be obtained from leasing. In either case, whether leased and effectually sold, or sold outright, the gas companies should sell at what seems at first thought a loss.

Take, for instance, the supposition, and it is a reality, of putting out 1,000 stoves a year. They would cost from \$16,000 to \$20,000, depending upon the size of the stove. This includes setting up, rent of stoves, salesman or clerk, and advertising.

Take as a basis for a few figures the cost at \$18,000. They will average to consume yearly 10,000 cubic feet of gas, making ten millions cubic feet per annum. Placing the profit at 50 cents per 1,000 cubic feet, which I think is low enough, the profit on gas consumed by 1,000 stoves would be \$5,000 each year.

Were you to lease the stoves at 25 per cent., your income from that source would be \$4,500, making \$9,500 yearly income, 52.7 per cent. interest on your investment.

Were you to sell the stoves at a loss of \$5 each, your income from gas sales would just offset that loss the first year, and bring your investment to \$13,000, upon which you would yearly derive 38.46 per cent. interest. These figures are given for your perusal, and especially for the smaller companies who feel the more heavily the loss made by electric lighting.

They can figure a smaller number of stoves pro rata, and are in some

respects better situated for the introduction of gas stoves. Of the practical results I have nothing to say, as every gas engineer knows them, and a fair trial by their consumers is conclusive. The methods of advertising are various, and must at first be pushed, for you have goods for sale and you must be more than a "Barkis" to your consumers.

Some companies have canvassed each house consumer with good results. Many have used the cooking schools to advantage, had the teachers lecture to their consumers, giving a practical demonstration of the results, and every company should have a salesman or clerk thoroughly conversant with their uses.

The inducement offered by some companies, by reducing the price of gas for manufacturing and cooking purposes, is commendable when circumstances prevent the reduction being made to all; and it takes but a survey of the gas stove field to see that low-priced gas is a prime factor.

In the discussion let me refer those whose efforts ten or even five years ago were unsuccessful, and who lament that theirs is not a gas stove community, to their more successful brother engineers, and urge them to make another effort, aided by others' experience, with a reduction in the price of both gas and stoves.

Discussion.

The President—In the discussion of that paper we shall be glad to hear from all those who have put out gas stoves largely within the past year. I think that Mr. Slater has rather carried off the palm for his method of introducing stoves, or rather by his ability in doing so. I will ask him to give the results of his experience in the introduction of gas stoves in the past few years.

Mr. Slater—We commenced the gas stove business three years ago next June. Our idea was to place the stoves, either by sale or by lease, or in any way that we could induce a consumer to take them; and for the reason that those who have sold gas stoves in Providence heretofore made it a special business, and expected to make something out of it, and did not meet with any great success, we determined to sell them at about the cost price. When we started in our point was to sell the stoves at what they cost us, or lease them at a moderate rental, and so place them within the means of the consumers, and thus induce them to try the stoves, knowing very well that when they once got a stove and used it they would not again be without it. The result was that during the first year we put out some 500 or 600 stoves; and during the last year and a half we have added still more to that number. I think that the most we put out in any one month was 310, in the month of June last. We now have more than 2,600 gas stoves in use; and I should say that the 2,600 stoves would not consume less than twenty million feet per year.

Mr. Allyn—Do you make a special rate for gas used in cooking stoves?

Mr. Slater—The same price as for other purposes.

Mr. Harbison—Can you state about what proportion of stoves are leased and sold?

Mr. Slater—Somewhere from two-thirds to three-fourths on the number of stoves in use are on lease. We find that many who take stoves on lease will afterwards purchase them. After having paid rent for one or two years, if they see fit to pay the balance of the cost of the stove, and own it, we allow them to do so.

Mr. Harbison—Do you find any difficulty in re-leasing a stove that has been once used to another family?

Mr. Slater—None at all. We take it to the shop and clean it up. If the customer wants to buy a stove we let him have a new one; if he wants to rent one we let him have one of those that had been used.

Mr. Harbison—What is your price for gas?

Mr. Slater—At present, \$1.40.

Mr. Harbison—Have you a special department for the stove business? Have you canvassers?

Mr. Slater—We have no canvassers. We have a store on the main street, and make a special department of the stove business.

The President—I find that gas stoves have been introduced successfully in most of the larger towns and cities. Have any of our friends tried them in the smaller towns? Does it pay to introduce them in the smaller towns? I think that Mr. Todd can tell us about that.

Mr. Todd—The plan which I have adopted is that of having a free lunch. My reason for adopting that plan was because I found, when I went to Middletown, N. Y., that the gas cooking stove was very little known. I hired an empty store on the principal street,

and put into it all the different kinds of cooking and heating stoves that in my judgment were the best. I set them all around the place, made the store as attractive as possible, and hired a lady to cook. I had a table spread, and all who came in were welcomed to help themselves. The free lunch and exhibition continued for four days. The first exhibition was two years ago. We found that a good many who came in to see the stoves would ask, will it do this, or will it do that; and we found that the best way of convincing them of its capabilities was to show them by an actual test just what it would do. Last year I did the same thing, and intend to have another exhibition in the month of May. As I have said, when I went there, the gas stove was unknown; but in two years I have put out over 80 stoves; and next year I expect to put out nearly as many more. When people inquire about them, I show them the stoves, and what they will do, and tell them that I will set one up free of cost, and that if, after a fair trial, they do not like it, I will take it out. I give each one a stove on trial for one month. If they do not like it, I take it out, and charge nothing for setting up or taking out, but as a matter of fact I have had to take back but one stove yet. We dispose of the stoves to consumers by selling them at cost, or renting them. The rental is twenty per cent. rent on the net cost, and if the stove is afterward sold to the party who has rented it, the amount paid as rent is allowed on purchase price.

Mr. Slater—We hire a store and pay \$1,800 rent per year for it, and have a good man to run the store, and we sell the stoves at cost and set them free of expense; so that you see what a profitable business we are making out of them, as far as that goes.

Mr. Harbison—Do you add the store rental, the salary of the man and the cost of making connections to the cost of the stove?

Mr. Slater—That has nothing to do with the rental at all. Our object is to get the consumer to the use stoves and burn gas.

The President—I would like to ask Mr. Goodwin whether in his experience in the gas stove business he has found any difficulty in introducing gas stoves in small places, as compared with larger towns.

Mr. Goodwin here stated his experience in the introduction of gas stoves; but at his request his remarks were not reported.

The President—I think Mr. Harbison has also had some experience in putting out gas stoves, and we would like to hear from him.

Mr. Harbison—The gas stove business has been an important factor with the Hartford Gas Company for a number of years. We have had a satisfactory degree of success thus far, considering the efforts that we have put forth. Our efforts have consisted wholly in having the stoves of different makers on hand, posting ourselves somewhat with regard to their capabilities for doing the work claimed for them, and by personal solicitation and representation of their merits to the people of Hartford in inducing them to buy the stoves. We have no faith in the system of giving away stoves. As is well known to most of the gentlemen present, we sell gas at the low rate of \$1.40 per thousand feet to the general public, and just now at even a lower rate than that to large consumers who use it for mechanical purposes—the rate depending upon the quantity they use—so that in some cases we are selling gas as low as \$1.25 per thousand feet. We have more than one stove in use for every four meters in the city of Hartford. Our output of gas between seven o'clock in the morning and five o'clock in the afternoon (which we call the day consumption) has been during the past year more than twenty per cent. of our entire output. We attribute the larger proportion of that to the use of gas in cooking stoves. We never have had a stove that has failed to do all that we represented it would do, when we sold it. We sell a stove with the proviso that if it does not do as we represent it will, we shall take it back and refund the money paid. We sell stoves at what it costs to deliver them at our works in Hartford. We charge the cost of making the connections. We have only one step more to take to become a strictly benevolent institution; but we do not take that step by giving away anything. Our customers are well satisfied with the stoves. We have no extra expense in connection with carrying on the business, because the labors of the men who set the stoves are paid for by the parties who buy them; and the stoves are sold in the office by clerks who are employed to do the clerical work of the office. Two or three of the clerks are well posted with regard to the merits of the stoves, and if one is not ready to attend to a customer, another one can. The only serious difficulty we have is with the cost of the stoves; and that objection is gradually being overcome by manufacturers making from time to time a small concession in price. As they increase their business, they come down a little on the price, which is very gratifying to us and pleasing to those who want to buy stoves. We are sure that continued reduction in price will increase the sales of stoves, so that the profits of manufacturers may be in-

creased by means of the largely increased business which will naturally come from the reduction of prices in stoves, just as a gas company increases its net income or profit by the largely increased business which results from a reduced selling price. The same principle applies in the manufacture of stoves as in the manufacture of gas. A large increase of business increases the net income, because the general expenses are not increased in proportion; and large sales at small profits increase the bank account. We make no profit on the stoves, but we do on the gas which is burned in them. We now have about 1,700 stoves in use in Hartford. During the past year we have seriously considered the question of putting at work a canvasser for the sale of stoves—every house in the gas district shall have a stove. We have more than 75 miles of mains in our city, and we think that by thorough canvassing, we can increase the sale of gas by a more general introduction of gas stoves, and that the increased sale of gas will compensate us for the additional expense. But we have not yet found the right party to go to work at the canvassing. It requires a party of some brains and intelligence, and of some little persuasive ability in talking, to act as a canvasser; and good canvassing agents are very hard to find. When we do find the right man, we have a job for him by way of experiment, if nothing more; and if he makes a success of it we will make the position permanent. I think it will pay every gas manager to give attention to the stove business; and he is very much better qualified to do so than any outsider who has no interest in the business except the profit which he can make by the sale of stoves. The business of the gas manager is to make and sell gas; and he ought to devote a certain proportion of his time, ability and intelligence to making that selling feature of the business prominent. It pays as well as any part of the business.

Mr. Woodward—Our experience has been very much like that of Mr. Harbison in the matter of leasing stoves. We found when we used to lease stoves (a practice which we have discontinued) that when our stoves came back again, we could not sell them at anything like their cost. On that account we discontinued the practice of leasing stoves, and now only sell them. We have been quite successful, and have about 250 stoves in use. Last year we gave away 50 small stoves; but I think there is some question whether that is a good policy, because it stops people from getting a larger stove which can do a great deal more work. I would like to know whether any others have had experience in the matter of giving away stoves; and, if so, how it compares with mine?

Mr. Neal—There is one objection to the use of gas stoves in place of ranges in the kitchen. Perhaps that difficulty has been obviated, but I do not know that it has. I refer to the difficulty of furnishing hot water for washing purposes. For instance, in my house in the summer time we use one of these stoves or ranges, but on Mondays there must always be a fire made in the coal range, because there is no other way of heating sufficient water for general washing purposes; nor have we any means by which we can heat water for use in the bathroom. That fact has been urged as an objection to the use of gas stoves in place of ranges—that when it is necessary to have hot water for general purposes, the fire must be made in the range. I would like to ask Mr. Norton if, in the sale of his stoves, he has any arrangement by which water can be economically heated by gas for the purposes I have mentioned.

Mr. Norton—None of the stoves have a regular hot water back. The stoves are used largely in summer time, when very little hot water is needed; but for Monday's washing, the people generally do as Mr. Neal states—light their coal stoves once a week.

Mr. Harbison—The difficulty stated by Mr. Neal is very easily overcome. Almost all gas stove manufacturers make a hot water generator which will do the work of heating water as thoroughly as the stove will do the cooking. There is no difficulty whatever about it. One of our citizens wanted to overcome that very difficulty, and we told him that the hot water generator would fill the bill. We guaranteed what it could do—having the maker of the generator to back our guarantee, he having told us personally what he claimed for his hot water generator, and stated that he would back it to do as he said, or respond for any loss or damage. Knowing that he was a responsible man we had no hesitation in repeating his statement. That generator we furnished and it was not to be paid for until it had fulfilled the conditions under which it was sold. The purchaser subsequently expressed himself in the most thorough manner as satisfied with the performance of the generator and promptly called for and paid his bill. That was the first generator which we sold. We have had no hesitancy since that time in recommending them, and in promising that they will give as good satisfaction as the cooking stove or range gives. You can have hot water for washing on Monday or on any other day of the week; or for bath purposes, or for any other use for which you want hot water.

(Further remarks were here made by Mr. Goodwin, which are omitted at his request.)

On motion of Mr. Harbison the thanks of the Association were voted to Mr. Norton.

The President—We will turn now from the discussion of hot water to another problem which may get us into hot water. The question of how to run a gas works and an electric light plant together.

Mr. S. J. Fowler, of Westfield, Mass., here read his paper on the
MANAGEMENT OF A SMALL GAS AND ELECTRIC LIGHT PLANT.

The problem of how to run the electric department of a gas company so as not to lose money and so that the department shall pay

dividends or interest on the money invested, is, I find, intricate and consequently interesting, and I hope so large a proportion of this audience is interested in the problem that my solution of the matter may not be unwelcome to you.

In its gas business our company has always pursued the policy of never making any private contracts. Our terms are public, and every customer can know what rate any other customer pays for gas. The same policy we try to carry out in our electric business. We do not believe in making one party carry the burden of capital charges and taking another customer at simply manufacturing cost. We are located in a town the closely settled portion of which contains probably about 7,000 inhabitants. We have a six-inch gas plant, with two benches, one of threes and one of sixes. There is nothing meriting especial mention about our gas works, except that, with the pressure of 100 lbs. on the town water mains, we use a water-jet exhauster, and have done so for the past ten years to our perfect satisfaction. Our make of gas for the last year was very close to 7,000,000 feet. Our price is \$2.50, with 5 per cent. off for prompt payment and an extra 5 per cent. off to consumers using more than 50,000 feet during the calendar year. We furnish about 300,000 feet for a gas engine at \$2.00 per 1,000. The State report of 1889 makes the average price of our gas to be \$2.34.

We bought out the local electric light company in the autumn of 1887, but, finding the plant as sold to us, entirely inadequate to our needs, we abandoned it, with the exception of its electric apparatus and built a brick station, 96 feet by 36 feet, one story high, with a high basement under the engine and dynamo room. Our boiler room is 36 feet by 32 feet, and contains two 54-inch return tubular boilers, of 70 horse power each, built to run at 125 lbs. pressure. The brick stack is 80 feet high and 4 feet square internally.

In our engine and dynamo room, which is 64 feet by 36 feet, are one 70 horse-power McIntosh & Seymour compound condensing engine, connected to two 30-light 9 ampère Schuyler, arc machines for street lighting, and one 100 horse-power engine of the same make and style, connected to one 45-light 7-ampère Schuyler dynamo for commercial lighting, and to one 500-light Thomson-Houston alternating incandescent dynamo. The remainder of the space in the engine and dynamo room is utilized as storehouse, workroom, etc.

In the basement is the condenser, which is supplied with water from the river, about 275 feet distant.

We had run our original electric plant long enough to be assured that there is no bonanza in the electric lighting business at the prices charged by our predecessors, and which seemed to us as high as our customers could afford to pay. We had, therefore, to look to increased business and a proportional diminution of expenses for our profits.

Our prices for electric lights are as follows:

For our street lights we get \$82.18 per year, or 22½ cents per night, for a 9 ampère lamp, running every night from 20 minutes after sundown until one A. M.

According to the report of the Gas and Electric Light Commissioners of last year this was the cheapest service given by any company in the State, and I have no hesitation in saying that the price is less than it should be to meet the proper charges for interest, repairs and manufacturing expenses.

For our commercial arc lamps we get \$100 per year, less a discount of 5 per cent. for each regular night in the week when the lamps are not used after six o'clock.

As a Gas Company, and in the lighting business to stay, we did not believe in a uniform rate per lamp, regardless of the number of hours burned. We therefore made a schedule, from which I select the following:

No. 1.—\$7.80 per year, 1 night in the week, until 9, 1 until 10, 4 until 6.	
“ 2.—\$12.00 “ “ 5 “ “ “ “ 9, 1 “ 11.	
“ 3.—\$13.80 “ “ “ “ “ “ “ “ 6 “ 11.	
“ 4.—\$15.00 “ “ every night until 11.	

The first rate is equivalent to 1½ cents per hour. The second to one cent per hour. The third to ¾ of a cent per hour, and the last to a little over ½ of a cent per hour; so that it is very plain that our charges are much lower per hour for long hours than for short ones.

Our lamps average us nearly 95 cents per month.

We have now wired:

On our street dynamos the equivalent of 63 arcs.

On our commercial arc dynamo the equivalent of 26 arcs.

On our incandescent machinery the equivalent of 330 16-candle power lamps.

Our commercial dynamos are run from early dusk until eleven o'clock every night, except Saturdays, when we run until half-past twelve. I am sometimes asked why we do not run later every night. My answer is that we cannot afford it. We should not have more than 15 or 20 lamps on the line after eleven, and any additional revenue we might derive from them would not pay for the oil used on the engine. The same is true of day service. Undoubtedly this policy of stopping rather than running longer at a loss has cost us some business and decreased our revenue somewhat, but it has lowered our expenses.

Except the first year that the electric light was introduced our increase in gas consumption has been about 8 per cent. per year, and we do not feel that electricity has damaged our gas business in the least.

During the last 18 months we have added about 60 per cent. to the output of power from our electric station.

The increase in our gas business has thus not been at the expense of our electric business, nor has the increase in our electric business been at the expense of gas. The two run along side by side, and, except in a few cases, do not compete; but the growth of both branches is made in new business and also by driving out kerosene oil.

For street lighting it is now generally admitted that arc lamps supply the popular demand for light better than anything else. We have on our streets 49 arc lamps and 6 Sims 25-candle power incandescent lamps, and our streets are illuminated to the general satisfaction of the citizens.

We have no public gas lamps, except 15 on the main thoroughfare of the town, which burn from 1 A. M., when the electricity is turned off, until morning.

For inside lighting arc lamps are in use in certain places, but in our small towns, where there is not a great extent of mercantile business, the cost—the necessary cost—is practically prohibitory to many of the business men, and, therefore, the arc lamp cannot be generally adopted, even if it were in all cases advisable.

The incandescent lamp and gas are our other means of supplying our customers, and it is of the relation of these two commodities that I wish particularly to speak.

Gas pipes are put into almost every building and customers supply their own fixtures, so that in connection with the use of gas the company is put to no expense beyond the running of the service and the setting of the meter.

For electric lighting our company does all exposed wiring, etc., free of charge, the only cost to the consumer being the lamps, which we sell at cost price. We believe it is a good thing for us to own the electric material in town, wherever it may be, as we thus have the right to take it away or change the wiring as we may desire without any great protest. I may add, however, that we chose to do free wiring when we put in our incandescent plant, as we then took out a great many series incandescent lamps which were perfectly satisfactory to our customers but which were, from a financial point, far from satisfactory to us.

Our experience shows the relation between the cost of furnishing electricity and of furnishing gas, to be this. The steam and labor required at the station to produce the electric current are cheaper than the coal and labor required to put an equivalent amount of gas into the holder, but in general the other expenses of manufacture and the cost of distribution, including all outside repairs under this head, are much greater in the case of electricity than in that of gas; and the expense of distributing electricity increases not according to the light supplied, but according to the possibility of supplying it to the various customers. It costs us about \$14 direct, immediate outlay for each and every lamp that we put in. If a converter is fully loaded, somewhat less; but if it is but partially loaded, somewhat more. Our average is \$14 exclusive of the lamp. If the wiring on private premises were not done at our expense, but at the expense of the customer, of course, the cost would be less to us, but would certainly not be less than \$10 per individual lamp even in that case, and this does not include any allowance for the proportionate capital in the station and steam plant. To surely meet all charges for interest, depreciation and repairs, we assume that at least \$2 per year must be allowed, therefore, it is our belief that if we cannot get enough in excess of \$2 out of a lamp to more than meet our manufacturing expenses, it is not to our advantage to have that lamp on our line. We have, therefore, not endeavored to do any private house lighting by our electric department, simply because we do not see how that department could possibly make any money by it. Its income might be increased, but it would be at the expense of the capital account, which is already more than as large as we care to have it.

When a light is to be but little used we believe gas is preferable, both to the company and to the consumer, being more reliable as regards supply, and less liable to accident as regards the fixture. We have, therefore, practically drawn the line at fifty cents per month, and do not care to put in any lamps which would net us less than that. This charge is so high that we have very few lamps on our lines which are not in use at least part of every week day, and we feel that we are utilizing our outlay for lines and electric machinery to the fullest extent, while at the same time a certain class of consumer is relegated to the use of gas.

But our price for gas is such that our saloons and other places which are open late in the evening, generally found it too costly for them, and before the introduction of electricity were using kerosene. Now kerosene has been displaced and we are furnishing electric light at a profit to us, but at a cost to the consumer considerably below that which would be incurred if gas were used.

We actually make a discount to our consumers for the electric light used during that portion of the evening when the demand would otherwise be small. We are obliged to furnish the largest quantity of electricity at a certain time and almost all the expense of the incandescent plant would be incurred if the current were to be developed only during the short time referred to, therefore, at other hours we can afford to charge our customers less per lamp hour. This is a carrying out of the principle so familiar in the gas business of charging less for gas for day consumption. We charge less for electric light used during the time when the mains are not fully utilized, and in this way we are enabled to compete with kerosene.

We have no metered lights, nor under our present system of running do we care for any. Being in a small place, we are able

to watch our customers fairly well and to know whether they are keeping to their contracts, and we are now under no obligation to have any lamps on our lines which do not bring in a regular income, whereas, if we used meters, we should almost be forced to put in lamps as our customers should wish, and the consequent charging per ampere hour would make electricity the direct competitor of gas, which we do not wish, and which we do not believe to be to the best interests of our customers or to the advantage of the company. For it is our opinion that we cannot have a lamp on our line which does not produce an income of at least \$6 per year without its causing us a certain loss.

This we reckon about as follows: Fixed charges against each lamp amount in our case to about \$2, which have to be more than covered before we can begin to earn a profit. If our profit in furnishing light amounts to 40 per cent., then our fixed charges would be met as soon as a lamp produced an income of \$5; but we demand a further income of \$1 to justify our risk in taking the lamp on to our line. These fixed charges we are forced to cover during the hours of heaviest lighting, and a study of our schedule will show that we succeed; but once they are covered we are able and willing to furnish light for longer hours at a very low price; for our business is conducted upon the principle and belief that electricity should be used for steady, continuous lighting, and gas in those places where artificial light is required but a portion of the time; for though we can furnish a given amount of light more cheaply by means of the incandescent lamp than by the use of gas, we require TIME in which to do it. Gas can be burned in such quantity and at such a time as our customers choose.

The length of time during which the electric light is to be used determines the economy of its supply and of its use.

Discussion.

The President—We have before us the question of how to successfully manage a combined gas and electric light plant, and many of us are interested in that subject. Perhaps Mr. Stiness will give us his opinion as to the position taken by Mr. Fowler.

Mr. Stiness—I feel a little hesitancy, at this late day, in speaking of electricity, after the greeting which the electric light men got this morning from the representative of that part of New England called Hartford, in the statement that it took a very bright man indeed to run gas works, but that any man could run an electric light plant. Having been engaged in that for so long a time, I have arrived at the conclusion that I do not know anything at all about electricity, and, therefore, perhaps the statement applies to myself. But the paper which Mr. Fowler has read follows in such close lines with my own experience, that if I were to write a paper on the same subject it would be almost identical with his. With our electric light plants (two electric light stations, equal to nearly 500 arc lights) and with a gas plant of about 70 millions output, we have followed on almost the identical lines which he has marked out. To one point of Mr. Fowler's I wish to refer. If I remember correctly, he said that he makes no special contracts. We have followed in that line ourselves. We have a price list which is put out to all. For us one man's money is as good as that of another. We have, as he has perhaps, different grades; but we furnish, and are compelled to furnish, a 20-candle lamp instead of a sixteen. It has been said by some one to-day that this should be called a "Light Association;" but I wish to say to those who suggest that, that the world moves. We are to-day receiving as members coal gas men, water gas men, and electric light men; but the future of the gas business is, in my judgment, as well assured as the future of the world—exactly. But the people must recollect, and these gentlemen who are concerned in or interested in the business must remember, that it makes no difference what we do; we have got to furnish what the public calls for, and if the public demands the electric light, that demand must be met. As I said one year ago, I looked forward with anticipations of hope that the future of artificial illumination will be far advanced at the end of the next decade of years from what it is to-day. By one speaker this morning it was said that there is a great deal of push in these electric light men. That is exactly what I admire in those gentlemen who have control of the electric lighting interest, not only in New England, but all over this country—they are men of push, they are men of energy; and, above all, there are men of scientific attainments standing behind them who rank with any men that the world can produce. I listened on Monday evening to a paper read by one of our Massachusetts Civil Service Commission, I think Mr. Lord. The electric lighting interests of Boston are taking gentlemen of that character, and are educating the public up to the benefits of electric lighting; and such a course will prove to be of great benefit to them. I will not go on any further in the elucidation of electric lighting; but it is a large field. You have to meet in active competition, unless you take it into your own household. I believe, as Mr. Fowler says, that the alternating system is not antagonistic to the gas company, but that they work together. For an intermittent service gas is decidedly the cheapest; but for a continuous service in the manner in which he speaks of, there are certain hours of the day when we can afford to give them that light at a much less rate, provided it will utilize the line. You know, Mr. President, and I know, that upon the first day of the week we are put to our trumps to find a place in which we may use the current which we must furnish to a few lights which we have on our circuit; and therefore we can go out and take in a seven day service on some lights, at a low rate, and yet make money. The

electric light business is a good paying business when properly managed. That is all that I have to say, except to add, after an experience in the consolidation and combination of gas and electric lighting, that it has not been done at the expense of the gas business. The latter pays us a fair remuneration, although not equal to the old substantial gas business.

The President—Mr. Coggshall has had a good deal of experience this last year in the electric light business, and probably he can give us his reasons for going into it.

Mr. Coggshall—My experience has been so limited that I am hardly prepared to give you facts such as I would like to give a body of men like this; but a year from now, if I live, I will tell you what has been the result of uniting the Fitchburg Gas and Electric Light Companies. The reason we went into it was that the old electric light company, having outgrown its plant, had to lay out a very large sum of money, and a combination of interests at that time seemed very desirable, and this was brought about one year ago. We have erected a new station, and have hardly got into it as yet. We have been running about one month. From our experience in that month we conclude that we are doing a very satisfactory business.

Mr. Holmes—I think that I am connected with the management of the smallest gas works (Winsted, Conn.) in New England, and perhaps the smallest electric light company. Our output of gas is less than two million feet per annum. We were making coal gas, and charging \$3.50 per thousand. We are now making water gas and charging \$2.50 per thousand, with a discount which gives it to the largest consumers at \$2 per thousand. We are running 40 arc street lights, the equivalent of about 30 commercial lights, not arc lights, but large incandescent lights, two in place of one arc, and also about 500 incandescent lights, of which number something over 100 are in factories. We were organized in 1860 to make oil gas, but got a renewed charter in 1872 or 1873 to make coal gas, and a couple of years ago got an additional charter allowing us to distribute electricity. We have earned in years past as much as 3½ per cent. net in making coal gas; but since we have made water gas and electricity we have earned a good deal more than that. It has been hard work to increase the gas consumption. We have no gas stoves except two or three small stoves in saloons, but we are going to try that on this summer. We run our electric lights by water power. That is probably where we make a great gain, as we have a phenomenal water-power for the electric light business, although it is situated four miles from the centre of the town. We have a water power with a fall of 53 feet which runs a 21 inch wheel 390 revolutions per minute, and can get 260 horse power from it, but are now using only about 100 horse power. We charge 75 cents per month for 16 candle power incandescent lights, giving a discount of five per cent. We get \$85 per year for our street lights, and are soon to reduce this price to \$80, and take on 10 more lights. We get about the same price for our commercial arc lights. We are pushing the business a little, are making some money, and are tolerably happy.

Mr. Harbison—I think those who have been for a term of years engaged in the business of manufacturing and selling coal gas are being left in the background and forgotten.

The President—Let me remind the gentleman that the question before us is the management of small gas and electric light plants.

Mr. Harbison—The paper of Mr. Fowler has a statement with regard to the comparative cost of electric and gas lighting; and, if I remember correctly, he said that the electric light, for certain uses, or for certain hours of the day, was cheaper than gas. But bear in mind that his gas is \$2.50 per thousand, and not \$1.40. If he were making his comparison on the basis of \$1.40 or \$1.50 per thousand for gas, his conclusions might have been different. There is one further matter that I want to call special attention to. When my friend from Vermont read his paper this morning he stated, in speaking of the advantages of water gas over coal gas, that 14 years ago he was charging \$3.50 for coal gas, but that ten years ago he put in a water gas plant, and reduced the price to \$2.50. But let him bear in mind that a great many of us were furnishing coal gas 14 years ago and were charging \$3.50 per thousand for it, just as he was, and that without putting in water gas plants we have been able to reduce the cost of coal gas to less than half the price we then charged. In fact, he would probably have been able by this time to sell coal gas for the same price he now sells water gas, if he had stuck to the coal gas business. While we may well consider the advisability of putting in a water gas plant as an auxiliary to a coal gas works, we should at the same time remember that in the last 14 years coal gas has made some considerable advance. We have not been at a standstill. I think that those engaged in the manufacture and distribution of coal gas can show as good results to-day as any water gas company in this country have been able to show. On motion of Mr. Harbison, a vote of thanks was passed to Mr. Fowler.

(A further discussion here followed with reference to the change of name of the Association, at the conclusion of which Mr. Lamson withdrew his motion. By direction of the President the motion and discussion are omitted.)

REPORT OF COMMITTEE ON NOMINATION OF OFFICERS.

Mr. Sherman, from the committee on the nominations of officers, presented the following report:

President—Charles F. Prichard, Lynn, Mass.

Vice-Presidents—Horace A. Allyn, Cambridge, Mass., and Wm. A. Wood, Boston, Mass.

Secretary and Treasurer—Chas. H. Nettleton, Birmingham, Conn.
Directors—Edward C. Jones, Henry B. Leach, Z. M. Jenks, Wm. Badger, and E. C. Learned.

On motion of Mr. Harbison, Mr. Sherman was instructed to cast the ballot of the Association for the election of the nominees of the committee.

The President—I declare that these nominees have been duly elected as officers of the Association for next year. Mr. Prichard will please come forward. (To the President-elect) These gentlemen, Mr. Prichard, have imposed upon you the highest honor which can be bestowed by this Association. It is an honor to be proud of, and in my judgment worthily bestowed; gentlemen, I introduce to you your President for the coming year.

Mr. Prichard—(President-elect)—Gentlemen, I can only say that I thank you most heartily for the honor you have done me, and I hope during the coming year that I shall be able to serve you to your satisfaction. But the President can do nothing without the hearty support and co-operation of the members. Let us unitedly endeavor to maintain and advance the interests of our Association.

THE WORLD'S FAIR COMMITTEE.

Mr. Harbison—At the last annual meeting of the American Association, held in Baltimore, in October last, the subject of a possible and probable World's Fair, to be held in 1892, was discussed, and a resolution was passed authorizing the council of the American Association to appoint a committee to represent that Association, to act in connection with committees appointed by kindred Associations, with special regard to an exhibit in connection with the gas industry to be made at that fair. It would be quite proper in my opinion, for this Association to take some action tending in the same direction. I therefore move that a committee of three be appointed by the chair to consider this question, and to report to the Association to-morrow the names of a committee to be appointed to represent this Association, and to act in connection with the committees of other Associations in respect to the World's Fair, whether it be held in 1892 or 1893.

The motion was agreed to, and the President appointed as such committee: Messrs. J. P. Harbison, H. A. Allyn and C. F. Spaulding.

BADGES.

Mr. Stiness—I notice that our friend Harbison wears a decoration. The American Association of Gas Engineers have adopted a distinctive badge, and the Guild of Gas Managers have also a badge, but there is no distinctive badge for the New England Association. It has been suggested that a committee be appointed to prepare a suitable badge to be worn by the members of the New England Association at its yearly meetings, so that a member can recognize a brother almost as well in the dark as in the light. It is a very convenient form of recognition. I met gentlemen in the hotel to-day whom I have seen here and have heard speak, but had no idea that they were in the gas business. I make the motion that a committee be appointed to prepare a permanent badge for the New England Association.

Mr. Harbison—I would like to second that motion, and to add to it that the committee be authorized to procure a suitable badge for members of the Association at the expense of the Association, and to see to it that each member has a badge before the next annual meeting.

Mr. Stiness—There is another question which enters in and which perhaps the committee can be prepared to report about to-morrow, and that is the matter of the cost of the badges. The badges of the American Association cost \$4 each, and I think a badge for this Association could perhaps be procured for a lesser sum—a different badge, say, for about \$3.

The President—I understand the motion to go so far as to direct the appointment of a committee to select a badge and report here to-morrow. This motion was amended by Mr. Harbison, that the cost of the badges should be paid for out of the funds of the Association. After some discussion the amendment was withdrawn and the motion prevailed. The chair appointed as Committee on Badges: Messrs. S. G. Stiness, C. F. Prichard and J. A. Coffin.

PRINTING THE PAPERS.

Mr. Lamson—I move that next year the papers which are to be read before the Association be printed and distributed among the members at the meeting.

The President—You have heard the motion of Mr. Lamson, that another year (as has been done in two instances this year) all our papers be printed before their presentation to the Association. (Adopted.)

NEWS FROM THE ABSENT SECRETARY.

The President—I have a telegram here from our Secretary which I should have noticed sooner, but was unable to do so:

"From Grand Island Depot, Nebraska. To Robert B. Taber, President of New England Association of Gas Engineers, Young's Hotel, Boston. Expected to be in Boston Tuesday, but was unavoidably detained. Best wishes for a successful meeting."

"CHARLES H. NETTLETON."

The Association then adjourned to Thursday, February 20, 1890, at 9:30 A. M.

(To be Continued.)

ITEMS OF INTEREST FROM VARIOUS LOCALITIES.

THE following, from a correspondent, under date of Feb. 28, at Boston, is, to say the least, interesting:

To the Editor AMERICAN GAS LIGHT JOURNAL:—Here is a chance for you to invest, as per the following advertisement: "Dedham Electric Company, organized under Massachusetts laws. Full paid capital stock, \$50,000. No bonded indebtedness. Subscription list for the stock, at \$100 per share, now open. Investigation will show that this stock will net the investor, from January 1st, 1890, at least 6 per cent. per annum, free of taxes. Orders for indoor lighting solicited. For further particulars and subscription list apply to JOHN R. BULLARD, President." The Company started up January 18, 1890, but is already, you see, prepared to divide 6 per cent. among its stockholders, who have not yet taken up the stock. You may ask why it is necessary to *advertise* the stock; but that's because you don't know how many 6 per cent. stocks are to be had in New England. You know the Atchison Company paid 7 per cent. while the last 10 millions of their stock was being issued! Six per cent. isn't anything where such investments abound. Yours, truly, *

It was remarked at the New England meeting last month that the electric lighting men were "pushing" individuals, and we fail to remember that that remark was controverted. And it goes without saying that the financial management of the Dedham Electric Company, as per their advertisement, are high in the class of "pushers." It requires a good deal of "push" nowadays to convince investors that any per cent. can be earned on the business of supplying electric lighting currents in small towns, and particularly so would this apply to a town of the size of Dedham, where a well-managed Gas Company already exists, also bearing in mind the fact that the projectors of the electrical enterprise feel that \$50,000 will be required to start the project on a commercial basis. Either Dedham wants electric lighting at new hands very badly, or else Mr. Bullard and his confreres are gasconading. Another thing that appeals to us in this connecting is, if Bullard & Co. have such a bonanza, why do they not interview the proprietors of the Dedham and Hyde Park Gas Company with the object of winning the latter over. The Dedham gas men know a good thing when they see it; but they, on the other hand, are also conversant with the practice of separating fancy from fact. That is, perhaps, why they have been so successful.

In our last issue brief mention (necessarily brief because of inability to obtain quickly the details of his life) was made of the death of Dr. H. H. Button, for many years President of the Milwaukee (Wis.) Gas Light Company. To the courtesy of a correspondent (whom we herewith thank for his kindness) we are enabled to give the following particulars respecting the career and work of Dr. Button: "Dr. Button died on Friday morning, Feb. 14th, from congestion of the brain. He was nearly 72 years of age, and had been very much affected by the death of his son-in-law, some three weeks since, who was a man in the very prime of life, full of vigor, possessed of unusual business ability, and who was warmly beloved by the Doctor. This relative had been ill only three days when death carried him off, and the shock to Dr. Button was most severe. Respecting the Doctor's connection with the Milwaukee Gas Light Company, I may say that he purchased his first stock in it in June, 1865, and was elected a Director the following month. After the death of Asael Finch (in March, 1883) the Doctor was elected President and continued to serve until death intervened. He was an excellent President, and took great interest in picking up the different points in gas manufacture, and educating himself in the new ideas advanced from time to time. Although very conservative in his ideas and ways, he was nevertheless anxious to keep up with the times, and to adopt all new methods that tended to cheapen the cost of gas, or to better its quality. He could not be excelled as a financier, and his personal integrity could not be questioned. He was in the very highest sense that the words imply, honest, kind and just. He was the leading advocate of the policy of reducing the price of gas in Milwaukee, and did much for the consumer in being so thoroughly persistent in his efforts in this direction. While it benefited the consumer at the same time, as you well know, it has been the means of putting this Company in the sound financial condition that it is. He will be greatly missed by his friends, and all those who had business connection with him. Mr. John L. Mitchell, now Vice-President, will doubtless succeed him. He is one of our largest capitalists, and will, I believe, be a splendid man in the place. His father (now dead) was Alex. Mitchell, for so many years President of the Chicago, Milwaukee and St. Paul Railroad. Yours, etc., E. G. C."

IT is reported that the proprietors of six large iron smelting or working furnaces in the vicinity of Pittsburg, Pa., are figuring on the possibility of substituting an artificial gas for the natural article. Among the six is mentioned the name of the Pennsylvania Tube Works Company.

A FEW days ago, Captain Supplee, in the second branch of the local government of Baltimore, Md., offered the following resolutions, which were referred to the Legislative Committee:

"Resolved by the Mayor and City Council of Baltimore, That the Legislative Committee be and is hereby instructed to present to the General Assembly of Maryland the following amendments to the measure now pending for the regulation of the contract for gas supply of Baltimore:

"*First.*—The Consolidated Gas Company shall have the exclusive right to manufacture and supply illuminating and fuel gas for 10 years in the city of Baltimore.

"*Second.*—The price charged the city for illuminating gas shall not exceed \$1.10 per 1,000 feet; the price charged private consumers shall not exceed \$1.25 per 1,000 feet.

"*Third.*—Whenever the dividends declared by the Company, after setting aside 1 per cent. as a sinking fund to extinguish its bonded debt, shall exceed 5 per cent. annually, the price of gas shall be reduced 5 cents per 1,000 to both the city and private consumers for each one-half per cent. dividend declared above 5 per cent.; that is to say, whenever the dividend declared shall be 5½ per cent. the price of gas shall be \$1.05 and \$1.20, respectively; when 6 per cent. shall be declared, the price charged shall be \$1 and \$1.15, respectively, etc."

AMONG the notable examples of bold engineering developed in the construction of the great sugar refinery of Claus Spreckels, at Philadelphia, Pa., one of the most unique is the hanging or aerial steam engine foundations. The engines used in this huge establishment are distributed practically all over the buildings, a large proportion of them being on the upper floors. Some of these engines are bolted to iron beams or girders on the second and third stories of the buildings, and are therefore innocent of all foundation. Some of these engines ran noiselessly and satisfactorily, while others produced more or less rattle and vibration. To correct the latter, the engineers simply suspended foundations from the bottoms of the engines, so that, in looking at them from the lower floors, they were literally hanging in the air. From this it would seem that the foundation to an engine does service merely from its weight alone. Hence it makes small difference whether the support be firmly imbedded in mother earth or in the air.

R. S. BLODGET, Chief of Police, Saratoga, N. Y., has adopted the following method of putting an end to stray dogs: A large box, with glass top and sides—the top being removable—is fitted with an ordinary ½-inch service pipe, leading from the riser that serves gas in the station. The doomed animals are placed in the box, the gas is turned on, and the end is accomplished. The first victim was a dog weighing 45 lbs.; the quantity of gas admitted was 8 cubic feet, and at the end of an exposure of a period of 2 minutes and 12 seconds the brute succumbed.

PRESIDENT McMILLIN, of the Laclede Gas Company, is responsible for the following: Some time ago (the month was December) a company announced its readiness to supply natural gas in Columbus, O. The proprietors had rented a large room for an office. Over a desk in a dark corner they placed a 2-burner fixture to use the ordinary manufactured article of gas, being more convenient for illuminating purposes than their own product. Around the room they placed various sample stoves, grates, etc., for burning natural gas to show the citizens how the thing worked. These were connected by various service pipes with their own main in the street, and were kept going all day. When New Year's came they had a big bill from the Columbus Gas Company. It was paid under protest. When February came around the size of that gas bill was something marvellous. It was such a veritable behemoth of a bill that the recipients got up and howled with all their might, ending with a peremptory demand that the offending meter be taken out in-stanter, or before it plunged them into hopeless bankruptcy. A mild-mannered gas employee came around promptly February 2d and read the meter preparatory to taking it away for good. It had been read Jan. 30, and in the three intervening days had recorded 3,000 cubic feet with only two burners going and its hands tied behind its back. The mild-mannered man was astounded. He hurried the meter away and tested it, feeling sure that something was radically wrong. But the meter refused to yield up its integrity. It came out of the test a meter to be proud of. It was all right. Then the mild-mannered man sat down be-

fore it and for a long time wrapped himself in thought as with a blanket. Finally a horrible thought struck him. He put on his hat and started for the office of the natural gas company. Half way there he met the chief clerk—the man who but an hour before had been the chief swearer in the matter—now meek as a lamb, coming to insist that the meter should be replaced at once, and only too anxious to “pay that outrageous gas bill.” He tried hard to keep from explaining, but the mild-mannered man was suspicious and persistent, and it had to come out at last. In tapping the pipes for the various sample stoves and grates a mistake had been made in one connection, and the pipe of the illuminating gas company had been tapped. For six weeks the natural gas people had been using about 25 feet an hour of manufactured gas, and selling natural gas by samples of the artificial article. Of course, the meter went merrily round and the bill went up. The natural gas people wanted the matter kept quiet, but this is so far from home that it won't count.

AT a meeting of the Directors of the Jacksonville (Ills.) Gas Light and Coke Company Mr. M. P. Ayres was elected President, and F. M. Doan was chosen Secretary and Superintendent.

AT a recent meeting of the Committee of Manufactures (Massachusetts Legislature) the matter under consideration was the taking of testimony in respect to the petition of the Amesbury and Salisbury Gas Company for the repeal of the State law (chap. 428, Acts of 1888) limiting the carbonic oxide content in illuminating gas to 10 per cent. One of the testifiers was Mr. C. W. Hinman, State Gas Inspector, who in his remarks went into the subject of water gas in a general way, and detailed the circumstances of the passing of the legislation of some years since in regard to water gas. He said he was largely responsible, perhaps, for the institution of the carbonic oxide limitation. His views, however, had been to a certain extent modified by subsequent experience, and if he had the same work to do over again he should do differently. He had known nothing of the commercial question involved in the oxide clause. Then he regarded it as a matter of little importance, and even the companies themselves made little objection to it. In rich water gas he testified there was no necessity for any oxide limitation, and that in 20-candle water gas 15 per cent. of carbonic oxide was not dangerous.

MESSRS. COFFIN & STANTON, of this city, as representatives of certain capitalists, have purchased for cash the property and franchises of the Crawfordsville (Ind.) Gas and Electric Light Company. We understand that Mr. P. C. Somerville will remain, for the present at least, Manager of the Company. He ought to be induced to remain there permanently.

A CONTROLLING interest in the Media (Pa.) Gas Company has been purchased by Mr. Francis M. Brooke. The cause which impelled him to become the heaviest shareholder in the concern is a queer one. Not long since he purchased at foreclosure sale a plot of ground close to the works, and subsequently acquired another piece in close proximity. The Gas Company's holder stands between the plots, and as Mr. Brooke is desirous of improving the property, he determined to secure control of the gas works, and thus be in position to order the relocation of the offending gasholder.

THE Mattoon (Ills.) Electric Light Company has turned on its current, and begins business with 36 arc lights in circuit.

THE Munn interest in the Freeport (Ills.) Gas Company has been purchased by Mr. L. F. Farwell, which gives to the latter complete control of gas and electric lighting supply of the town.

THE proprietors of the Atlantic City (N. J.) Gas and Water Company have arranged to put in a 16-inch main, from the works, down Michigan avenue to Atlantic, and a 12-inch from Atlantic to Pacific avenues.

THE proprietors of the Greenville (O.) Gas Company have agreed, until further notice, to sell gas at uniform rate of \$1 per 1,000 cu. ft.

ON February 22d, the buildings in which were housed the electric lighting apparatus of the Freeport (Ills.) Gas Light and Coke Company, were destroyed by fire. The loss is returned at \$25,000, and the insurance carried was only \$3,000. The disparity between the amounts mentioned is accounted for on the ground that the insurance rates on risks of this class are very high; further, that insurance companies are by no means anxious to assume such risks. In the Freeport instance the boiler house was a frame structure, and it was in that building that the fire originated. This unfortunate occurrence caused much annoyance to the residents, as the Company has the contract for carrying on the

public lighting, which is on the arc plan, but as Superintendent Runner was authorized by Mr. Farwell to rent power for the operation of an emergency dynamo, the interruption to the street lighting was of but short duration. The station will be rebuilt at once, with brick power buildings, however.

A GAS COMPANY for Vinton and Roanoke, Va., has been organized, and its bill for incorporation has been passed by the Legislature.

IT is now a certainty that the property and franchises of the Indianapolis Gas Light and Coke Company, the Indianapolis Citizens Gas Light Company, and the Indianapolis Natural Gas Company, have passed under the control of the Equitable syndicate of this city. The following circular will prove of interest in this connection:

“OFFICE OF THE EQUITABLE GAS LT. CO., OF NEW YORK, }
340 THIRD AVE., NEW YORK, Feb. 21, 1890. {

“I beg to call your attention to the fact that a syndicate, composed of some of the largest stockholders in this Company, has just completed the purchase of the gas business (lighting and fuel) of Indianapolis, consisting of various natural gas and fuel, illuminating gas, and electric light companies now in existence there, and has organized thereon the Indianapolis Gas Company, and now offers at private subscription a certain portion of the bonds of the new company. These bonds are 30-year gold 6 per cent. bonds, coupons payable April and October, and are offered at par with a bonus of 25 per cent. of stock. This stock will have an immediate and large dividend paying capacity, as the business is already established and is increasing rapidly and steadily. Payments on subscriptions will be through the Central Trust Company, of New York, by installments of 25 per cent., commencing March 15 and ending June 2. In case you want to participate in this enterprise, which will be one of the most successful in its line ever carried on in this country, please let us know at once; and, if you wish further particulars as to the present earnings of the business and its prospects in the future, I shall be glad to furnish them to you if you will call at this office. Very respectfully yours, — — —.”

WHILE no doubt the amalgamated lighting interests of Indianapolis will constitute a much more imposing enterprise than did the Indianapolis Gas Light and Coke Company, when taken singly—although we have an idea that that arm of the new confederacy is the member that shall convey the greatest force to the confederacy—we are nevertheless sorry that its destiny is to be destroyed—if not destroyed, at least cloaked. The history of the old company is that of fair-dealing, which clothed it with power that was never abused. And much of that history can be traced to the master hand of one known to his fellows as the “Sage of Indianapolis”—James Somerville.

WHEN General Manager Ellison, of the St. Paul Gas Company applied to the Building Department of the city for a permit to restore the structure recently damaged by explosion, he was astonished to find that a protest against the reconstruction had been lodged by several property holders in the vicinity of the works. The objection was based on the ground that the works were a menace to life and property; also that their operation tended to reduce the value of the surrounding holdings. The permit, however, we are informed was granted, the inspector alleging, and very properly, “that the gas plant was built many years before most of the residences were constructed, and that the Company has rights and privileges that cannot consistently be overlooked.”

AT a recent meeting of the Fredericksburg (Va.) City Council Mr. McCracken presented a resolution (which was adopted) containing an act for the construction and operation of a gas works on municipal account. The act is now before the Legislature.

WE understand that the City Council of St. Joseph (Mo.) has agreed to the proposition for a charter for an opposition gas company, under the pledges submitted by F. F. McGuire and his backers. The leading points in the ordinance are: The City Engineer is to have supervision over all street excavations and the subsequent repaving. Any injury resulting to persons or property, by reason of the construction of the works, to be settled for by the Company. The Company shall have on the ground, by August 1, 1890, three miles of pipe for distributing gas, one mile of which shall be laid, and shall also have begun the construction of its plant, and shall within 18 months after the acceptance of the franchise be prepared to furnish gas along at least 10 miles of pipe. The Company shall deposit \$20,000 cash with the Comptroller as a guarantee of good faith, 60 days from the acceptance of the franchise, the money to remain on deposit until the Company shall have given satisfactory evidence of having invested \$150,000 in the plant, a bond of \$20,000 to

be deposited at the same time. The maximum price of gas to be 75 cents per 1,000 cubic feet for fuel purposes, and \$1 per 1,000 for illuminating use. The city hall, engine houses and calaboose are to be lighted free of charge. The ordinance is to be accepted within 20 days after its passage. If the Company ever consolidates with any other Company the price of gas is not to exceed that named in the ordinance. The gas is to be odorized. This ordinance may give trouble to the authorities of St. Joseph in the near future.

OWING to the unprecedented rise in the Kentucky river, gas was shut off from Frankfort on the evening of March 1st.

THE Van Buren (Ark.) Investment Company has been incorporated by Messrs. W. H. H. Shibley, Geo. R. Wood, J. N. Brown, W. H. Ross and W. P. Brown. It is capitalized in \$50,000. One of the purposes of its formation is to construct and operate a gas and electric light works. This place is the capital of Crawford county, Ark., and is on the north bank of the Arkansas river, at a point about 9 miles northeast of Fort Smith. Population, about 4,000.

PRESIDENT ALLSTATTER, of the Board of Trustees of the Hamilton (O.) municipal gas works, is of the opinion that the works will be in operation on or before April 22d.

THE Philadelphia *Record* of March 3d contains the following: "The purifying house of the large gas works connected with the saw works of Henry Diston & Sons, at Tacony, Pa., blew up shortly after 8 o'clock yesterday morning. The building in which the explosion took place was constructed of brick, 1 story high, and located some distance from the other buildings. It was completely wrecked, together with the machinery. All the gas used in the blast furnaces and for lighting the works and the streets and residences of Tacony was purified in the destroyed building. The watchman noticed something wrong at an early hour in the morning, and started off to find one of the engineers. Before the latter arrived the explosion occurred. The loss to the buildings and machinery will not be great, but the loss to the works will be considerable, owing to the loss of time before new machinery can be procured and set up. In the meantime Tacony will be without gas."

THE Fairfield (Iowa) Gas and Electric Company, with a capital stock of \$50,000, has been incorporated.

IN the reorganization of the Monroe (Mich.) Gas Light Company the capital has been put at \$40,000.

THE Columbus (O.) Gas Company is experimenting, on a practical working scale, with the Gordon regenerative street lamp as an agent for street lighting.

IN response to the invitation of the Troy (N. Y.) authorities to tender for public lighting, the Troy Gas Company proposed the following: Not less than 280 arcs (1,200-candle power), 38 cents per light per night; 2,000-candle power, 42 cents per light. If a 3-year contract be allowed, the respective prices to be 37 cents and 41 cents; if for 5 years, the rates to be 37 cents and 39½ cents, respectively. Under the gas lighting head of the specifications, the Troy Gas Company offered the following: 310 Gordon lamps and 625 boulevard lamps (ordinary pattern), to be maintained under the schedule, at \$39,420 for 1 year's service; 370 Gordon lamps and 625 boulevard lamps, \$44,238; 450 Gordons and 620 boulevard pattern, \$49,056; 625 ordinary street lamps, 8½ cents per night each. Gas to public buildings, \$1.50 per 1,000. It would perhaps be a surprising thing were Troy the first city in this country to adopt a sensible plan of lighting streets by gas—that is, in respect to a new, but eminently satisfactory system.

MR. GEO. D. CURTIS, well known to the fraternity of Central New York, from his connection with the Albion Gas Company, has removed to Atlanta, Ga.

THE ordinance regulating the price of gas in St. Louis, which was vetoed by Mayor Noonan, has been passed over the veto by the Municipal Assembly. The vote was 9 to 3.

CAPT. D. H. HENSLEY, Secretary of the Hamilton (O.) Gas Light Company, has been appointed local postmaster.

MESSRS. T. F. OAKES, Crawford Livingston and General H. H. Sibley have been elected Directors in the St. Paul Gas Light Company. The first named is supposed to represent the recently-acquired interest in the Company secured by Mr. Henry Villard.

THE Rockford (Ills.) Gas Company has been purchased by the American Gas Company, of Philadelphia.

THE Poughkeepsie (N. Y.) Gas Light Company has brought suit against Wm. O'Riley for \$52.50, which sum the plaintiff claims is due because of defendant's negligence in the construction of a sewer through Main street. On account of faulty shoring the Gas Company's main was fractured, thus causing a loss of 45,000 cubic feet of gas. The defense interposed is a general denial, coupled with the statement that, as the work was being done on city account, O'Riley is not the real defendant.

Coke Brick for Furnace Linings.

The *Iron Age* says that at the last meeting of the German Society of Iron and Steel Metallurgists, F. Burgers, of Gelsenkirchen, presented a short statement of his experience with a special brick used to line the bosh and hearth of blast furnaces. It is a matter of frequent occurrence that linings 3 to 4 feet thick are soon reduced to a few inches. Then streams of water must be used to keep the walls from being destroyed. The chief reason for this rapid destruction of the refractory material is the fact that the cinder dissolves it, fluctuating in its composition, as it does frequently, from an acid to a basic cinder. Experiments made showed that the best refractory firebrick, varying in composition, were destroyed in one or two hours when placed in the cinder run. This circumstance led Burgers to seek for another material. His attention was directed to coke. The first experiment, begun in 1882, was directed to binding with clay, coal, coke, and graphite, and using the mixture in a form of brick. Dr. Otto & Co., a leading firm of German manufacturers of firebrick, furnished a series of samples which, however, were defective in this point—that in binding the brick the carbon had been partly removed; but even this sample gave good results.

In 1885 Pourcel, in describing the manufacture of ferromanganese, at Terrenoire, stated that the hearth and bottom of the furnace were made of graphite brick. He used as a raw material retort graphite containing 1 to 2 per cent. of ash, ground it, mixed it with tar, formed it into brick, and then heated it. A part of the tar cokes and binds the graphite to a solid brick. Burgers had experiments made with ground coke, low in ash, instead of graphite, obtaining good results.

In 1885 No. 2 furnace of the company with which Mr. Burgers is connected was lined with this coke brick, with excellent results. They have been introduced also with the Rheinische Steel Works, and at Rombach. At Mechernich the same material has been used for lining lead furnaces. During the course of a brief debate upon the subject, Burgers stated that the cost of the brick is about 100 marks per ton.

Recent Patent Issues.

The following list of recent patents relating to the gas interests is specially reported by Franklin H. Hough, solicitor of American and foreign patents, 925 F street, N. W., Washington, D. C.

ISSUE OF FEBRUARY 4, 1890.

- 420,726. Gas Regulator. C. P. Kolm, Knapps Creek, N. Y.
420,751. Gas Washer. W. T. Walker, Bishopswood Road, Highgate, England.

ISSUE OF FEBRUARY 11, 1890.

- 421,217. Gas Burners, Heating Attachment for. J. A. Wilson, Baltimore, Md.
421,263. Gas Furnace for Melting Metals. H. H. Garrett, Pittsburgh, Pa.

ISSUE OF FEBRUARY 18, 1890.

- 421,606. Gas Burner. A. G. Morey, LaGrange, Ills.
421,473. Gas Engine. H. J. Baker, Chicago, Ills.
421,474—421,475 and 421,477. Gas Engines. J. C. Beckfeld and A. Schmid, Allegheny, Pa.

ISSUE OF FEBRUARY 25, 1890.

- 421,924. Gas Burner. T. Gordon, Philadelphia, Pa.
422,299. Gas and Air Mixer. J. W. Danforth and R. W. Clark, Buffalo, N. Y.
422,173. Gas Washer. F. A. M. Alavoine, Beauvais, France.

WE understand that the bill regulating the gas supply of Baltimore, Md., has passed the lower branch of the State Legislature, the vote being decisively in its favor. The only substantial amendment to the bill is that which reduces the time (for which the grant to the Consolidated Company is to be exclusive) to 15 years from 25. Well informed people give it as their belief that the Senate will indorse the bill.



A. M. CALLENDER & CO.,

PROPRIETORS,

EDITOR—Jos. R. Thomas, C.E.

ASST. EDITOR—T. J. Cunningham.

MANAGER—C. E. Sanderson.

PUBLISHED ON EACH MONDAY OF THE YEAR AT

No. 42 Pine Street, New York.

This is a recognized official organ of
LIGHT, HEAT, STEAM, WATER SUPPLY,
VENTILATION, SANITARY IMPROVEMENT,
AND GENERAL SCIENCE

TERMS:

SUBSCRIPTION—Three Dollars per annum, in advance. Single copies, 10 cents.

AGENTS.

NEW YORK.—AMERICAN NEWS Co., 39 and 41 Chambers Street.
PHILADELPHIA.—PRATT & Co., Corner Ninth and Arch Streets.
Germany.—B. WESTERMANN & Co., of New York.

MONDAY, MARCH 10, 1890.

The Market for Gas Securities.

The city market for gas shares shows no marked change in quotations over those reported for last week. In general the tone is weaker, although this is to be attributed more to lack of inquiry for securities than to any real cause concerning either the management or business of the properties affected. Brooklyn shares are steady to strong, with but little stock offering. Baltimore gas keeps fairly steady, and the probability is that still higher figures in it will shortly be recorded. The measure introduced into the House giving to the Company the exclusive right to manufacture gas in Baltimore for a term of years, in consideration of certain moneys annually paid to the city treasury, has passed that branch of the Legislature, and this seems to us to be equivalent to its final enactment, for it is more than rumor that the Senate will interpose no objection. The Governor also favors the measure, if certain unofficial utterances of his about it are to be accepted as indicative of his leanings. President Morris, of the Louisville Company, has officially announced that to-day that Company will be ready to furnish a non-illuminating fuel gas, at the rate of 50 cents per 1,000. This experiment will be watched with interest, and Mr. Barret, will come in for no small share of congratulation should his studies in this direction lead to success.

It is more than likely that the Troy (N. Y.) Gas Company will absorb the Troy Electric Light Company's plant. In any event the city's public lighting has been awarded the Gas Company, and as the contract calls for both gas and electric lighting, the contractors might do worse than absorb their competitor, a competitor, however, that was never over strong. Mr. Thomas Turner has been re-elected President of the Charleston (S. C.) Gas Light Company, and the Directors are: Messrs. A. S. Johnson, W. B. Smith, John S. Riggs, Geo. W. Williams, Morris Israel, H. E. Young, G. L. Buist and John C. Simonds.

Gas Stocks.

Quotations by Geo. W. Close, Broker and Dealer in Gas Stocks,

16 WALL ST., NEW YORK CITY.

MARCH 10,

All communications will receive particular attention.
The following quotations are based on the par value of \$100 per share.

	Capital.	Par.	Bid	Asked
Consolidated.....	\$35,430,000	100	95½	96
Central.....	500,000	50	—	—
“ Serip.....	220,000	—	—	—
Equitable.....	4,000,000	100	119	122
“ Bonds.....	1,000,000	—	113	115
Harlem, Bonds.....	170,000	—	—	—
Metropolitan, Bonds....	658,000	—	116	118
Mutual.....	3,500,000	100	110	—
“ Bonds.....	1,500,000	—	100	102
Municipal, Bonds.....	750,000	—	—	—
Northern.....	—	50	—	—
“ Bonds.....	150,000	—	—	100
Standard Gas Co—				
Common Stock.....	5,000,000	100	45	—
Preferred.....	5,000,000	100	87	90
Yonkers.....	—	50	112	—
Richmond Co., S. I....	346,000	50	—	—
“ Bonds.....	20,000	—	—	—
Gas Co's of Brooklyn.				
Brooklyn.....	2,000,000	25	109	111
Citizens.....	1,200,000	20	68	70
“ S. F. Bonds..	320,000	1000	100	103
Fulton Municipal.....	3,000,000	100	121	124
“ Bonds....	300,000	—	100	105
Peoples.....	1,000,000	10	80	82
“ Bonds (5's).....	368,000	—	100	—
“ “ (6's).....	94,000	—	100	—
Metropolitan.....	1,000,000	100	93	96
Nassau.....	1,000,000	25	115	—
“ Cdfs.....	700,000	1000	120	122
Williamsburgh.....	1,000,000	50	120	123
“ Bonds... ..	1,000,000	—	108	112
Out of Town Gas Companies.				
Boston United Gas Co. —				
1st Series S.F. Trust	7,000,000	1000	93	93½
2d “ “ “	3,000,000	1000	71	72
Bay State Gas Co. —				
Stock.....	5,000,000	50	24	25
Income Bonds.....	2,000,000	1000	—	—
Buffalo Mutual, N. Y... ..	750,000	100	90	95
“ Bonds... ..	200,000	1000	95	100
Citizens, Newark.....	1,000,000	50	155	160
“ “ Bonds.	45,000	—	—	—
Chicago Gas Trust.....	25,000,000	100	44½	—
Chicago Gas Light. & Coke Co. —				
G't'd Gold Bonds	7,650,000	1000	—	93½
Equitable Gas & Fuel Co., Chicago, Bonds	2,000,000	1000	97	—
People's Gas and Coke Co., Chicago—				
1st Mortgage.....	2,100,000	1000	—	99
2d “	2,500,000	1000	96	100
Consumers Gas Light Co., Jersey City.....	2,000,000	100	15	25
Bonds.....	600,000	1600	80	—
Cincinnati G. & C. Co..	6,000,000	100	201	203
Consumers Toronto....	1,000,000	50	190	200
Central, S. F., Cal.....	—	—	80	90
Capital, Sacramento, Cal	—	—	58	—
Consolidated, Balt.....	11,000,000	100	54	54½
“ Bonds.....	6,400,000	—	107	107½
Hartford, Conn.....	750,000	25	102	108
Jersey City.....	750,000	20	186	190
Laclede Gas Light Co., St. Louis, Mo.—				
Common Stock....	7,500,000	100	14½	15½
Preferred “	2,500,000	100	—	—
Bonds.....	9,034,400	1000	84½	—

Louisville, Ky.....	2,570,000	50	125	130
Little Falls, N. Y.....	50,000	100	—	100
“ Bonds	25,000	—	100	103
Montreal, Canada.....	2,000,000	100	200	208
Memphis (Tenn.) Gas... ..	750,000	100	48	51
“ Bonds.	240,000	100	103	—
New Haven, Conn.....	—	25	200	—
Oakland, Cal.....	—	—	35	35½
Peoples, Jersey City... ..	—	—	60	61
“ “ Bonds..	—	—	—	—
Paterson, N. J.....	—	25	99	102
Rochester, N. Y.....	—	50	99	100
Syracuse, N. Y.....	500,000	25	—	—
San Francisco Gas Co.				
San Francisco, Cal....	10,000,000	100	55½	55¾
Washington, D. C.....	2,000,000	20	200	208
Wilmington, Del.. ..	—	50	88	90

Advertisers Index.

GAS ENGINEERS.	Page
Jos. R. Thomas, New York City	344
Wm. Henry White, New York City.....	347
Wm. Mooney, New York City.....	344
William Gardner, Pittsburgh, Pa.....	344
Fred. Bredel, N. Y. City.....	343

GAS WORKS APPARATUS AND CONSTRUCTION.

James R. Floyd & Sons, New York City	347
Continental Iron Works, Greenpoint, L. I.....	347
Delly & Fowler, Phila., Pa.....	347
Kerr Murray Mfg. Co., Fort Wayne, Ind.....	335
Stacey Mfg. Co., Cincinnati, Ohio.....	347
Bartlett, Hayward & Co., Baltimore, Md.....	345
Morris, Tasker & Co., Limited, Phila., Pa.....	345
Davis & Farnum Mfg. Co., Waltham, Mass.....	295
R. D. Wood & Co., Phila., Pa.....	346
Bouton Foundry Co., Chicago, Ills.....	347
Smith & Sayre Manufacturing Co., New York City.....	346
Fred. Bredel, N. Y. City.....	343
United Gas Improvement Co., Phila., Pa.....	337
National Gas Light and Fuel Co., Chicago, Ills.....	338
Simpkin & Hillyer, Richmond, Va.	332

GAS AND WATER PIPES.

Gloucester Iron Works, Phila., Pa.....	344
Mellert Foundry and Machine Co., Reading, Pa. (John Fox, Selling Agent, N. Y.).....	344
Ohio Pipe Co., Columbus, Ohio.....	344
M. J. Drummond, New York City.....	344
R. D. Wood & Co., Phila., Pa.....	346
Warren Foundry & Machine Co., New York City.....	344
Donaldson Iron Co., Etnaus, Pa.....	344
Dennis Long & Company, Louisville, Ky.....	344

PROCESSES.

National Gas Light and Fuel Co., Chicago, Ills.....	338
Bartlett, Hayward & Co., Baltimore, Md.....	345
Wm. Henry White, N. Y. City.....	347
United Gas Improvement Co., Phila., Pa.....	337

INCLINED RETORTS.

Laclede Fire Brick Manuf'g Co., St. Louis, Mo.....	335
--	-----

GASHOLDER TANKS.

W. C. Whyte, New York City.. ..	338
J. P. Whittier, Brooklyn, N. Y.....	339

GASHOLDER PAINT.

The Government Waterproof Paint Co., Boston, Mass.....	332
--	-----

RETORTS AND FIREBRICK.

J. H. Gautier & Co., Jersey City, N. J.....	342
B. Kreisler & Sons, New York City.....	342
Adam Weber, New York City.....	342
Laclede Fire Brick Manuf'g Co., St. Louis, Mo.....	342
Brooklyn Retort and Fire Brick Works, Brooklyn, N. Y.....	342
Borgner & O'Brien, Phila., Pa.....	342
James Gardner, Jr., Pittsburgh, Pa.	342
Henry Maurer & Son, New York City.....	343
Chicago Retort and Fire Brick Co., Chicago, Ills.....	342
Baltimore Retort and Fire Brick Co., Baltimore.....	342
Oakhill Gas Retort and Fire Brick Co., St. Louis, Mo.....	342

SCRUBBERS AND CONDENSERS.

G. Shepard Page, New York City... ..	336
R. D. Wood & Co., Phila., Pa.....	346

REGENERATIVE FURNACES.

Bartlett, Hayward & Co., Baltimore, Md.....	345
Fred. Bredel, New York City.....	343
Chicago Retort and Firebrick Co., Chicago, Ills.....	342
Wm. Henry White, N. Y. City.....	347
J. H. Gautier & Co., Jersey City, N. J.....	342

GAS GOVERNORS.

Connelly & Co., New York City..... 339
 Fred. Bredei, N. Y. City..... 343
 Friedrich Lux, London, England.. 331

SELF-SEALING MOUTHPIECE DOORS.

Smith & Sayre Mfg. Co., New York City..... 346

TAR AND CARBONIC ACID EXTRACTOR.

Geo. Shepard Page, N. Y. City..... 296

CEMENTS.

C. L. Gerould & Co., Brooklyn, N. Y..... 342

GAS ENRICHERS.

Standard Oil Co., Cleveland, Ohio..... 348

GAS METERS.

John J. Griffin & Co., Phila., Pa..... 350
 American Meter Co., New York and Philadelphia... 351
 The Goodwin Gas Stove and Meter Co., Philadelphia, Pa... 351
 Helme & McIlhenny, Phila., Pa..... 351
 D. McDonald & Co. Albany, N. Y..... 351
 Nathaniel Tufts, Boston, Mass..... 350
 Maryland Meter and Manufacturing Co., Baltimore, Md... 350
 Bell & Jones, Philadelphia, Pa..... 350

EXHAUSTERS.

The P. H. & F. M. Roots Co., Connersville, Ind..... 334
 Smith & Sayre Manufacturing Co., New York City..... 346
 Wilbraham Bros., Philadelphia, Pa..... 339
 Connelly & Co., New York City..... 339

GAS COALS.

Penn Gas Coal Co., Phila., Pa..... 349
 Perkins & Co., New York City..... 348
 Newburgh Orrei Coal Co., Baltimore Md..... 349
 Despard Coal Co., Baltimore, Md..... 349
 Chesapeake and Ohio R. R. Coal Agency, N. Y. City..... 349
 Westmoreland Coal Company, Phila., Pa..... 348
 J. & W. Wood, New York City..... 348

CANNEL COALS.

Perkins & Co., New York City..... 348
 J. & W. Wood, New York City..... 348

VALVES.

Ludlow Valve Manufacturing Co., Troy, N. Y..... 340
 John McLean, New York City..... 340
 Chapman Valve Manufacturing Co., Boston, Mass..... 340
 R. D. Wood & Co., Phila., Pa..... 316
 The P. H. & F. M. Roots Co., Connersville, Ind..... 334

GAS ENGINES.

Schleieber, Schumm & Co., Phila., Pa..... 352
 Clerk Gas Engine Co., Phila., Pa..... 340
 Van Duzen Gas Engine Co., Cincinnati, Ohio..... 340

ENGINES AND BOILERS.

Jarvis Engineering Co., Boston, Mass..... 339
 Ball Engine Co., Erie, Pa..... 332
 Westinghouse Machine Co., Pittsburgh, Pa..... 343

GAS LAMPS.

G. Shepard Page, New York City..... 300
 Weisbach Incandescent Gas Light Co., Phila., Pa..... 333
 The Siemens-Lungren Company, Philadelphia, Pa..... 333

PURIFIER SCREENS.

John Cabot, New York City..... 310
 Bartlett, Hayward & Co., Baltimore, Md..... 340

GAS STOVES.

American Meter Co., New York and Philadelphia..... 341
 The Goodwin Gas Stove and Meter Co., Phila. Pa..... 312
 George M. Clark & Company, Chicago, Ills..... 333
 D. McDonald & Co., Albany, N. Y..... 351
 Maryland Meter and Manufacturing Co., Baltimore, Md..... 310
 Bell & Jones, Philadelphia, Pa..... 350
 Chicago Gas Stove Company, Chicago, Ills..... 332

STREET LAMPS.

J. G. Miner, Morrisania, New York City..... 332
 Bartlett Street Lamp Man'g Co., New York City..... 332

BURNERS.

C. A. Gefrorer, Phila., Pa..... 348

STEAM BLOWER FOR BURNING BREESE.

H. E. Parson, New York City..... 340

PURIFYING MATERIAL.

Connelly & Co., New York City..... 339
 Friedrich Lux, London, England..... 331
 Edgewater Lime Works, Edgewater, N. J..... 332

COKE CRUSHER.

G. M. Keller, Columbus, Ind..... 349

ELECTRICAL APPARATUS.

Wm. Henry White, N. Y. City..... 347

SOLVENTS.

Maas & Waldstein, New York City..... 339

BOOKS, ETC.

Gerould's System Gas Bookkeeping..... 331
 1889. Directory. 1889..... 342
 King's Treatise..... 344
 Scientific Books..... 350
 Management of Small Gas Works..... 340
 Gas vs. Electricity..... 332
 Practical Electric Lighting..... 339
 Electric Light Primer..... 339
 American Gas Engineer and Superintendents' Handbook... 349
 Digest of Gas Law..... 332
 Fuel and its Applications..... 331
 Newhigging's Handbook..... 343

WANTED,

A young man to act as

Meter Taker and to Make Himself Useful

in a small Gas Works. Must understand gasfitting and be strictly temperate. Address, with references, 768-2 "G.," care this Journal.

POSITION WANTED

As Manager of a Gas Works

Making from 5 to 10 million cubic feet per annum. Six years' experience. Address "J. M. M.," 767-4 Care this Journal.

POSITION WANTED.

A Mechanical Engineer,

Experienced in Gas Manufacture, wishes a position as Superintendent of a Gas Works. Best of references given and asked. Salary, \$1,200.

"MECHANICAL ENGINEER," care this Journal, 765-tf or Box 972, West Bay City, Mich

Position Wanted

As Superintendent or Assistant of a Gas Works,

By a man who can give the best of references. Thoroughly understands the manufacture and distribution of gas and the construction of works. Address 770-3 "M.," care this Journal.

FOR SALE,

The Ironwork for 11 Benches of 5's, viz.:

Cast Iron Hydraulic Mains, 17 inch diameter, inside.

Dip Pipes, Bridge Pipes, Stand Pipes.

Mouthpieces and Lids.

Four Purifiers, 10 by 16 ft., with 10-inch Connections and dry Center Seal.

Four Purifiers, 5½ by 10 ft., with 6-inch Connections and Wet Center Seal.

Valves, 6-inch, 8-inch, and 10-inch.

DAVID MOORE, Treas. Salem Gas Lt. Co.,

770-tf Salem, Mass.

FOR SALE.

We offer the following gas apparatus for sale, delivered f.o.b. cars Fort Worth, Texas:

Two Benches of 3's, with cast iron Hydraulic Main, Dip and Ascension Pipes, and Mouthpieces (14 by 23 in.).

One Bench of 6's, with cast iron Hydraulic Main, Dip and Ascension Pipes, and Mouthpieces (12 by 20 in.)

Two Benches of 3's, with cast iron Hydraulic Main, Dip and Ascension Pipes, and Mouthpieces (14 by 24 in.).

Four Purifiers, 6 ft by 6 ft., with 6-in. Connections and Center Seal. Steam Jet Exhauster. One Set Pipe Condensers (6-in.). One Upright Scrubber, 11 ft. high by 36 in. diam., with Bye-Pass. One Station Meter, daily capacity 100,000 cu. ft. One Upright Boiler, 20 horse power.

All of above apparatus in first-class condition and are so guaranteed. For further particulars address

FORT WORTH LT. AND POWER CO.,

767-4 Fort Worth, Texas.

GAS WORKS FOR SALE.

A CONTROLLING INTEREST IN SEVERAL

Interior California Coal Gas Plants,

now paying handsomely, are offered on very reasonable terms. This is an exceptionally good opportunity for practical gas men of limited means, wishing to remove to a mild and healthful climate, to acquire an established and paying business. Particulars given and full investigation solicited.

SECRETARY, 123 Beale Street,

760-3 mos.

San Francisco, Cal.

FOR SALE.

A Complete Water Gas Plant.

60,000 Cu. Ft. Daily Capacity.

Fully equipped; all the latest improvements; includes Generator, Purifiers, and Holder. Can be removed to any part of the country, and set up at small cost. For further information apply to BRADFORD GAS LT. & HEATING CO., Dunkirk, N. Y

FRIEDRICH LUX,

Ludwigshafen am Rhein and London.

Lux Mass

GAS GOVERNORS,

Gas Balance.

6 PER CENT.

First Mortgage Bonds

ON GAS WORKS

SITUATED IN GROWING WESTERN TOWNS.

Principal and Interest Guaranteed.

INTEREST SEMI-ANNUALLY.

For sale by the undersigned, who will furnish all necessary information regarding them.

JOS. R. THOMAS, 42 Pine St., N. Y. City.

Fuel and Its Applications.

By E. J. MILLS, D.Sc. F.R.S., and F. J. ROWAN, C.E., assisted by others, including Mr. F. P. Dewey, of the Smithsonian Inst., Wash., D. C.

7 PLATES, AND 607 OTHER ILLUSTRATIONS. ROYAL OCTAVO. PAGES XX, 802. HANDSOME CLOTH, \$7.50.

A. M. CALLENDER & CO., 42 Pine St., N. Y.

GEROULD'S

System Gas Bookkeeping.

Approved and adopted by many of the prominent Gas Engineers of the Country.

Sample Sheets and Price-List furnished free on application to

L. P. GEROULD, - - Mendota Ill.

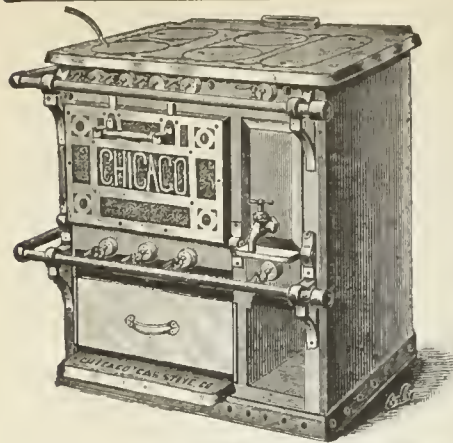

CHICAGO GAS STOVE CO.

MANUFACTURERS OF ALL KINDS OF

Gas Cooking and Heating

APPLIANCES.

117-119 Lake St., CHICAGO.

Send for Catalogue.

EDGEWATER LIME WORKS

Chas. F. McKenna, Proprietor.

SHELL LIME.

Lime by the Cargo for Gas Purification.

EDGEWATER, BERGEN CO., N. J.

Write for Testimonials and Prices.

GASHOLDER PAINT.

Use Only

THE GOVERNMENT WATERPROOF PAINT.

Proof against Ammonia, and Absolutely Waterproof. Send for Prices and Particulars.

THE GOVERNMENT WATERPROOF PAINT CO., 122 Milk Street, Boston, Mass.

Simpkin & Hillyer

RICHMOND, VA.

MANUFACTURERS OF

Gas Works Apparatus

BENCH CASTINGS, CONDENSERS,

Scrubbers, Purifiers, Dry Center Seals,

FOUR-WAY VALVES, GAS VALVES,

SULPHATE OF AMMONIA APPARATUS,

TANKS, ENGINES, BOILERS,

PUMPS, ETC., ETC.

Plans, Specifications and Estimates furnished for new works, or alteration of old works. Correspondence solicited. Works, Newport News, Va.

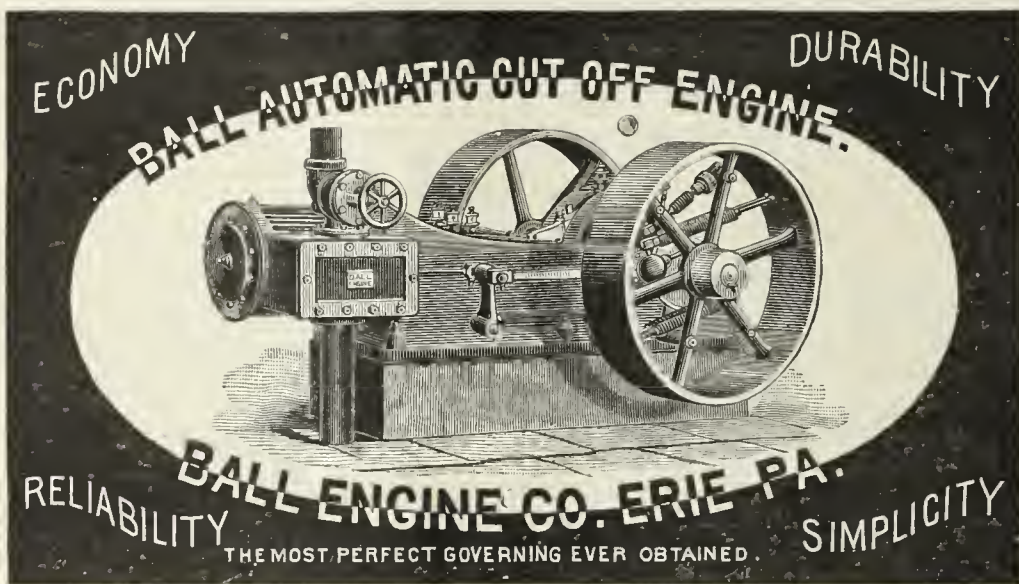

Bartlett Street Lamp Mfg. Co.

MANUFACTURERS OF

Globe Lamps,

FOR

Streets, Parks, Public Buildings, Railroad Stations, etc.

LAMP POSTS

A Specialty.

Office and Salesroom,

40 & 42 COLLEGE PLACE, - - N. Y. CITY.

Gas Companies and others intending to erect Lamps and Posts will do well to communicate with us.

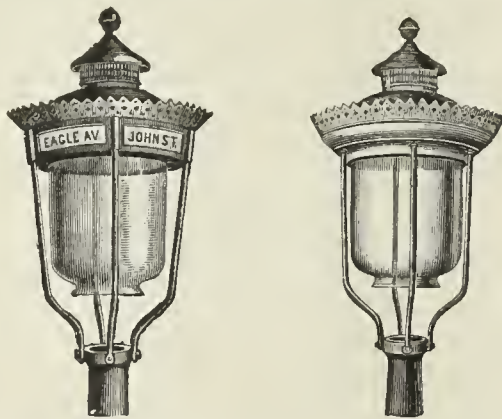

The Miner Street Lamps.

Jacob G. Miner,

No. 823 Eagle Ave., New York, N. Y.

GAS vs. ELECTRIC LIGHT.

We would invite attention to the able and exhaustive argument of General A. Hickenlooper, President of the Cincinnati Gas Light and Coke Company, contained in a handsome pamphlet of 96 pages, entitled

"EDISON'S INCANDESCENT ELECTRIC LIGHTS FOR STREET ILLUMINATION. REPORT OF AN ARGUMENT DELIVERED BY A. HICKENLOOPER BEFORE THE COMMITTEE ON LIGHT, MUNICIPAL COUNCIL, CITY OF CINCINNATI, JULY 22, 1886."

This is a subject of special interest to all Gas Light Companies.

Prices.

25 copies.....	\$7.50	100 copies.....	\$22.50
50 copies.....	12.50	250 copies.....	50.00

A sample copy will be sent by mail on receipt of 50 cts.

A. M. CALLENDER, & CO., 42 PINE ST., N. Y. CITY

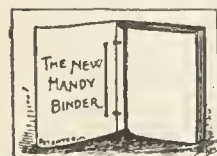

THE NEW HANDY BINDER.

This article may be described as elegant in appearance, strong, durable, and possessing many special qualities of its own. It allows the opening of the pages perfectly flat, whether one or several numbers are in the binder. Any number can be taken out and replaced without disturbing the others. The papers are not mutilated for subsequent binding in permanent form. The binder is supplied with gilt side title, and is an ornament to any desk or reading table. The JOURNAL, filed in the Handy Binder, becomes a volume of great value, always convenient for instant reference. Handy Binder, Postage paid, \$1.00.

A. M. CALLENDER & CO., 42 Pine St., N. Y.

GREENOUGH'S

"DIGEST OF GAS LAW."

Price, \$5.00.

This is a valuable and important work, a copy of which should be in the possession of every gas company in the country, whether large or small. As a book of reference it will be found invaluable. It is the only work of the kind which has ever been published in this country, and is most complete. Handsomely bound. Orders may be sent to

A. M. CALLENDER & CO.,

42 Pine Street, N. Y.

PATENTS.

FRANKLIN H. HOUGH

Solicitor of American & Foreign Patents.

925 F. ST., WASHINGTON, D. C.

(NEAR U. S. PATENT OFFICE.)

Personal attention given to the preparation and prosecution of applications for Letters Patent. All business before the U. S. Patent Office attended to for moderate fees. No Agency in the United States possesses superior facilities for obtaining Patents, or for ascertaining the patentability of inventions. Copies of patents furnished for 25 cents each. Correspondence solicited.

The Gordon Portico Lamp.

A successful Competitor of the Arc Electric Light for lighting Store Fronts, Show Windows, Depots, Railway Sheds, etc., etc.

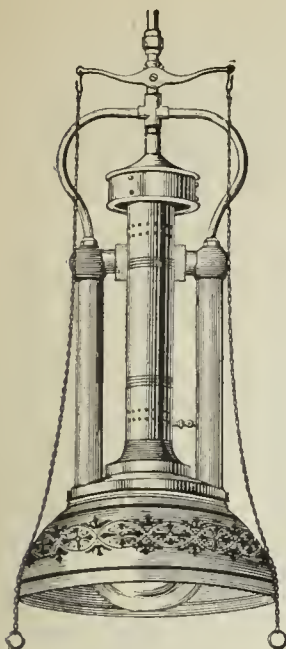

Gordon Portico Lamp.

The Gordon Street Lamp.

A Successful Competitor of the Arc Electric Light for lighting Streets, etc., etc.

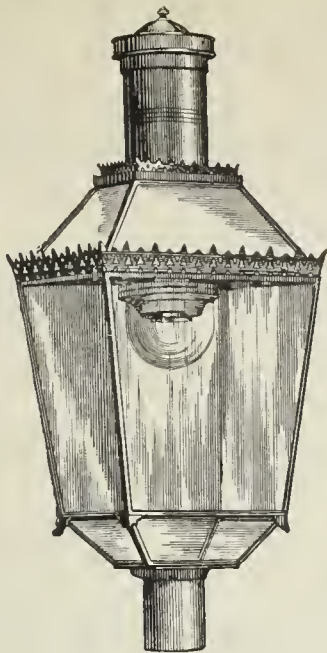

Gordon Street Lamp.

The Lungren Lamp.

A Successful Competitor of the Incandescent Electric Light for Interiors, etc. Is especially applicable for the lighting of Offices, Stores, Factories, Mills, Show Windows, Libraries, and all situations where an increased illumination is desired.

More than 25,000 Lungren Lamps are now in use. Testimonials, references, or any desired information will be cheerfully given.

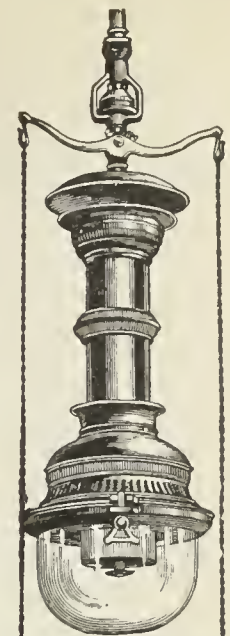

Lungren Lamp.

THE SIEMENS-LUNGREN CO., N.E. Cor. 21st St. & Washington Av., PHILADELPHIA.

WELSBACH SYSTEM OF Incandescent Gas Lighting.

OFFICE, DREXEL BUILDING, PHILA., PA.

At the Fall Session of the Board of Supervisors of Winnebago County, held at the County Court House, Oshkosh, Wis., Nov. 26, 1889, the report submitted by Mr. C. W. Cook, Chairman of the Committee on Public Buildings, recommending the use of the Welsbach Incandescent Gas Burner in the Buildings under their charge, was unanimously adopted, because of the extreme economy in the consumption of Gas and the superior character of the light obtained.

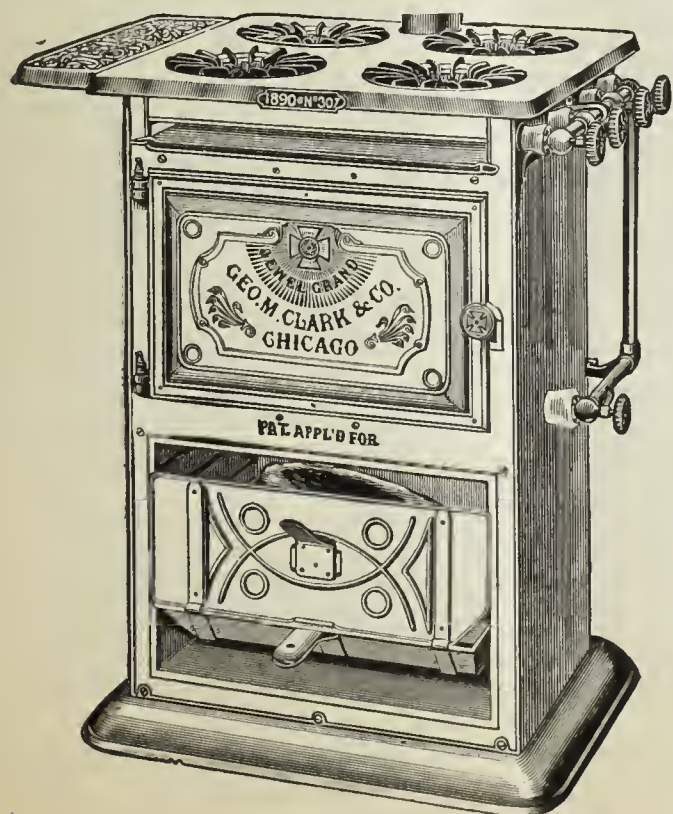

JEWEL GAS STOVES

MANUFACTURED BY

GEORGE M. CLARK & COMPANY,

Nos. 157 & 159 Superior Street, - - - Chicago, Ill.

EVERY CONCEIVABLE SIZE AND STYLE,

Ranging in Prices from \$1.50 to \$30.00.

WE USE NO GAS COCKS.

All Flames are Regulated by a Direct Needle Valve.

The JEWEL

IS THE

Only Well-Made Gas Stove on the Market.

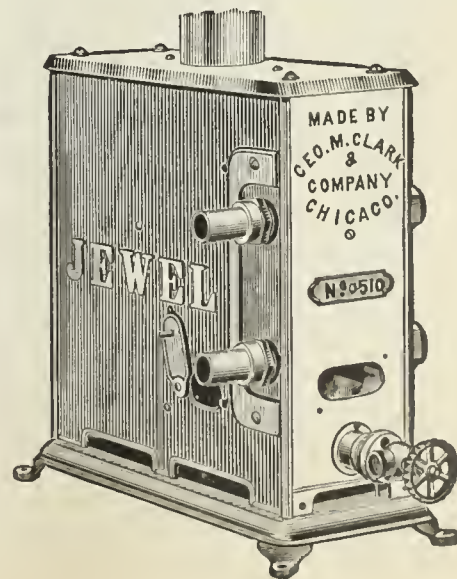

Write for our 1890 Catalogue and see for yourself.

ROOTS' GAS AND BYE-PASS VALVES.

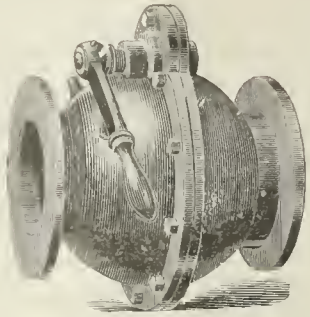

GAS VALVE

Quick Acting,
Simple,
Efficient, Durable.

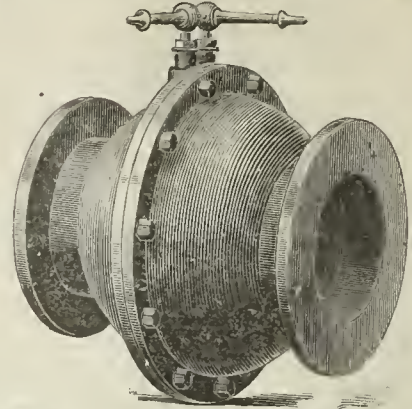

BYE-PASS VALVE.

Automatic Action,
Reliable,
Simple, Durable.

Thousands now in use and giving perfect satisfaction. Write for Catalogue and Prices.

ROOTS' NEW GAS EXHAUSTER.

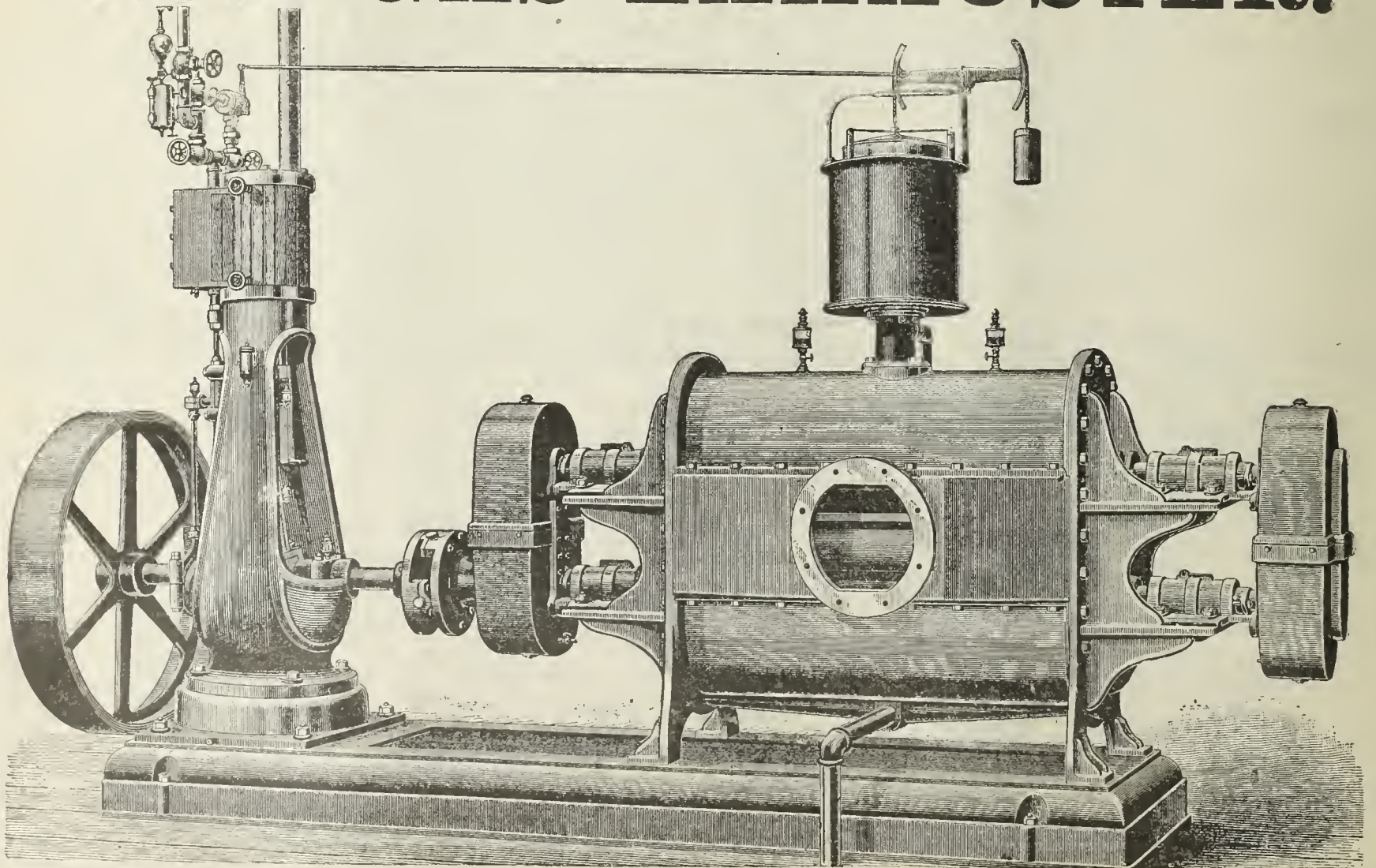

THE P. H. & F. M. ROOTS CO., Patentees and Manufacturers, **CONNERSVILLE, IND.**

S. S. TOWNSEND, Gen. Agt., 22 Cortlandt St., N. Y.

COOKE & CO., Selling Agts., 22 Cortlanat St., N. Y.

THIS SPACE
 WILL BE
 Occupied Next Month by the
KERR MURRAY MFG. CO.
 FORT WAYNE, IND.
**GAS WORKS
 APPARATUS
 AND
 HOLDERS.**

LACLEDE FIRE BRICK MANUFACTURING COMPANY,

ST. LOUIS, MO.

Exclusive Agents in the United States

FOR THE

Coze System of Inclined Retorts.

IT IS THE COMING BENCH
FOR MAKING COAL GAS.

*It will Save from 50 to
60 per ct. in Labor.*

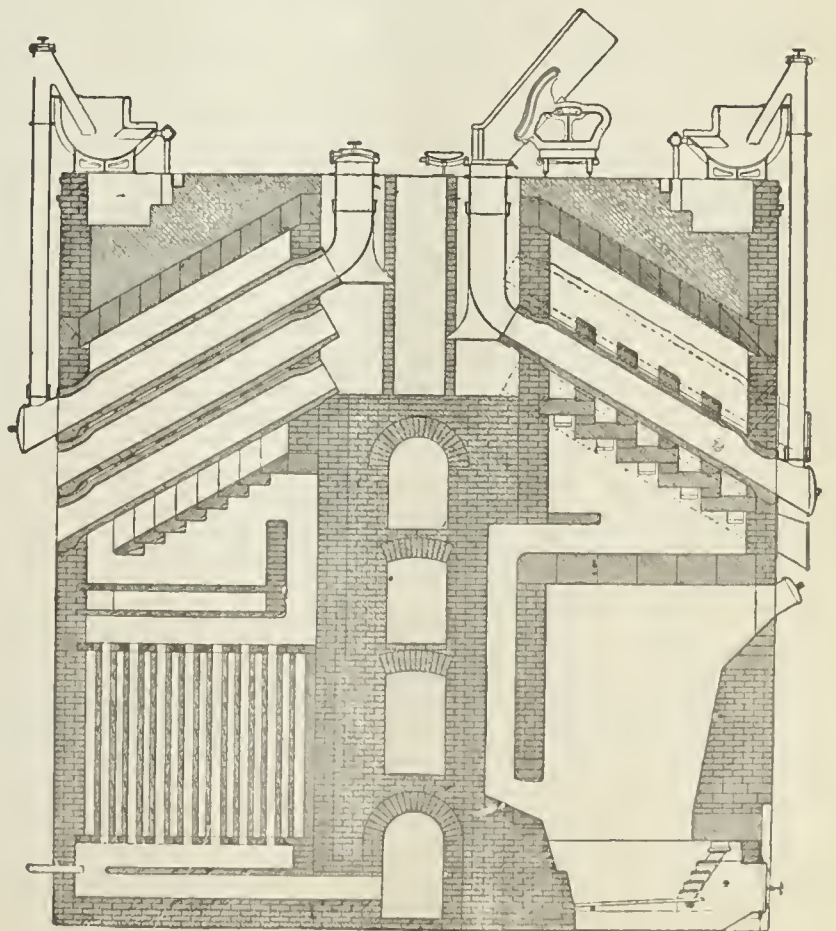
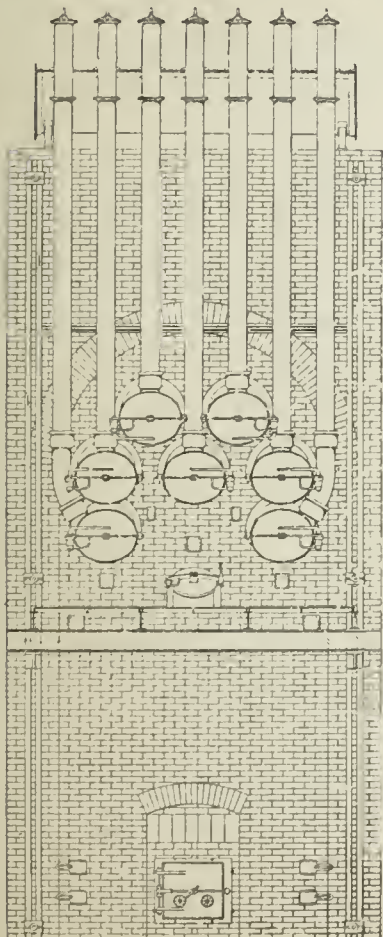

ESTIMATES AND PLANS FURNISHED BY THE

LACLEDE FIRE BRICK MFG. CO., ST. LOUIS, MO.

KIRKHAM, HULETT & CHANDLER, LIMITED.

PATENT "STANDARD" WASHER-SCRUBBERS

Erected and in course of construction at present date:

Capacity. Cubic feet per day.	Capacity. Cubic feet per day.	Capacity. Cubic feet per day.	Capacity. Cubic feet per day.
Altrincham..... 600,000	Dublin..... 3,000,000	LONDON—Continued.	Ober Schlesian 1,500,000
Adelaide..... 600,000	Dowlais..... 100,000	Shoreditch..... 2,500,000	Otto & Co.'s Coke Works..... 1,500,000
Aldershot..... 200,000	Donai..... 500,000	Pancras..... 1,500,000	Plymouth..... 2,000,000
Allegheny, U. S. A..... 1,000,000	Denton..... 500,000	"..... 1,500,000	Parramatta, N. S. W..... 100,000
Ashton-under-Lyne..... 1,250,000	Derby, U.S.A. 350,000	Pimlico..... 2,000,000	Prescott..... 150,000
Amsterdam..... 1,500,000	Denver, " " 500,000	Nine Elms..... 3,000,000	Providence, U.S.A. 750,000
"..... 1,500,000	"..... 1,000,000	"..... 3,000,000	"..... 750,000
Annaberg..... 200,000	Dusseldorf..... 750,000	South Metropolitan Co:—	Plauen..... 300,000
Arcachon..... 100,000	"..... 500,000	Greenwich..... 3,000,000	"..... 300,000
Animal Charcoal Co..... 200,000	Dumfries..... 250,000	Woolwich..... 400,000	Portsmouth..... 2,500,000
Altoona, U.S.A..... 350,000	Dunedin, N.Z..... 400,000	Vauxhall..... 3,000,000	"..... 2,500,000
Buxton..... 250,000	Darlington..... 1,250,000	"..... 3,000,000	Pittsburgh, U.S.A. 1,500,000
Bradford..... 1,000,000	Detroit, U.S.A. 750,000	Lea Bridge..... 300,000	Portland, " " 560,000
"..... 1,250,000	Edinburgh..... 1,500,000	West Ham..... 1,500,000	Pawtucket, " " 500,000
"..... 1,250,000	"..... 2,000,000	Leeds..... 2,000,000	Quebec 250,000
"..... 1,250,000	Enfield..... 300,000	"..... 3,000,000	Radcliffe..... 750,000
"..... 1,000,000	Essen..... 300,000	"..... 3,000,000	Rouen..... 250,000
"..... 1,000,000	Elbing..... 150,000	"..... 3,000,000	Ramsgate..... 1,000,000
"..... 3,000,000	Falmouth..... 150,000	"..... 3,000,000	Reigate..... 200,000
Bremen..... 150,000	Frankfort..... 300,000	"..... 3,000,000	Richmond, U.S.A. 250,000
Baltimore, U.S.A. 1,000,000	Farnworth..... 400,000	"..... 3,000,000	Roxbury, " " 500,000
"..... 1,000,000	Fenton..... 400,000	"..... 3,000,000	Runcorn Soap Co..... 20,000
"..... 1,000,000	Friedenshutte..... 500,000	"..... 2,000,000	Rockhampton, N. S. W..... 125,000
Balmain, N.S.W..... 125,000	Furth..... 400,000	Leominster..... 150,000	Richmond..... 1,500,000
Bishops Stortford..... 150,000	Freiburg..... 200,000	Leiden..... 560,000	Reading..... 2,000,000
Blackpool..... 400,000	Goole..... 250,000	"..... 600,000	Reichenbach..... 200,000
Brussels..... 1,250,000	Glossop..... 300,000	Liverpool..... 2,000,000	Salford..... 1,750,000
"..... 1,250,000	Guildford..... 300,000	"..... 2,000,000	"..... 1,750,000
"..... 750,000	Gloucester..... 1,250,000	"..... 2,000,000	"..... 1,750,000
"..... 1,250,000	Gera..... 300,000	"..... 2,000,000	Smethwick..... 750,000
Banbury..... 250,000	Grafton, N.S.W..... 100,000	"..... 2,000,000	Sydney, N. S. W..... 1,000,000
Birmingham..... 5,000,000	Grieg..... 300,000	"..... 3,000,000	"..... 1,000,000
Birkenhead..... 2,500,000	Georgetown, U.S.A. 250,000	Lincoln..... 1,000,000	"..... 2,500,000
Blackburn..... 1,500,000	Gluckauf..... 200,000	"..... 600,000	"..... 50,000
Bochum..... 600,000	Heywood..... 600,000	Lowell, U. S. A 1,000,000	"..... 50,000
Burntisland..... 250,000	Hollywood..... 125,000	Louisville " " 1,500,000	Sunderland..... 1,500,000
Boston, U.S.A. 2,000,000	Huy..... 70,000	Long Eaton..... 500,000	St. Josephs, U.S.A 250,000
Brisbane..... 1,500,000	Harrow..... 250,000	Lilie..... 900,000	Spa..... 100,000
"..... 300,000	Harrogate..... 250,000	"..... 450,000	Sevenoaks..... 300,000
Burton-on-Trent..... 1,500,000	Halstead..... 150,000	"..... 750,000	St. Petersburg..... 2,000,000
Barcelona..... 350,000	Heilbronn..... 200,000	"..... 250,000	"..... 1,500,000
Barking..... 100,000	Havana, Cuba. 750,000	"..... 250,000	St. Louis, U.S.A. 2,000,000
Baerlien & Co..... 20,000	Hastings..... 1,500,000	Luckenwalde..... 330,000	"..... 2,000,000
"..... 20,000	Huddersfield..... 300,000	Liegwitz..... 300,000	"..... 1,000,000
Bombay..... 400,000	"..... 750,000	Lincoln, U. S. A. 250,000	Laclede 1,000,000
Buffalo, U.S.A., Mutual 750,000	"..... 1,500,000	Lawrence " " 500,000	Silesian Coal Co..... 600,000
"..... Citizen 500,000	Hof..... 200,000	Lynn " " 300,000	San Francisco, U.S.A. 2,000,000
Brookline, U.S.A. 500,000	Hampton Wick..... 500,000	Lyons..... 1,500,000	"..... 2,000,000
Bergen..... 350,000	Heckmondwicke..... 500,000	Maidstone..... 1,000,000	Sheepbridge Coal Co..... 40,000
Berlin..... 1,250,000	Haverfordwest..... 100,000	Marseilles..... 1,500,000	Stettin..... 200,000
Bournemouth..... 1,000,000	Halifax, N.S. 350,000	"..... 1,500,000	Singapore..... 300,000
Bridgeport, U.S.A. 500,000	Hamm..... 200,000	Mons..... 500,000	Sutton..... 500,000
Brunswick..... 300,000	Halle..... 400,000	Malines..... 250,000	Tonbridge..... 150,000
Beck & Co., St. Louis 100,000	Heidelberg..... 300,000	Melbourne..... 1,500,000	Tipton..... 400,000
Barmen Rittershausen..... 600,000	Hartford, U.S.A. 1,000,000	"..... 1,500,000	Tottenham..... 1,000,000
Bexhill..... 125,000	Ilkeston..... 300,000	"..... 1,500,000	Toledo, U.S.A. 750,000
Brooklyn, U.S.A. 1,000,000	Inverness..... 250,000	"..... 1,500,000	Toronto 1,000,000
"..... 1,000,000	Ilkley..... 200,000	"..... 1,500,000	Uxbridge..... 300,000
"..... Nassau 1,000,000	Ilford..... 100,000	Manchester..... 2,500,000	Valparaiso 500,000
Brunner, Mond & Co..... 400,000	Kingston-on-Hull..... 400,000	Middleton..... 400,000	West Bromwich..... 1,000,000
Cheltenham..... 2,000,000	Kidderminster..... 750,000	Manley, N. S. W..... 100,000	Willenhall..... 250,000
Cannes..... 200,000	Kidsgrove..... 100,000	Minneapolis, U. S. A. 750,000	Weston-super-Mare..... 500,000
Croydon..... 1,500,000	Konigberg..... 1,000,000	Magdeburg..... 300,000	Waltham..... 150,000
Copenhagen..... 200,000	King's Lynn..... 300,000	Memphis, U. S. A 750,000	Wormwood Scrubs..... 300,000
Clevedon..... 200,000	LONDON:—	Nottingham..... 1,250,000	Williamsburg, U.S.A. 600,000
Columbus, U.S.A. 500,000	The Gaslight and Coke Co.:	"..... 2,500,000	"..... 600,000
Cincinnati, " " 1,500,000	Beckton..... 1,250,000	"..... 2,500,000	Wellington..... 150,000
"..... 1,500,000	"..... 1,250,000	"..... 2,000,000	Warwick..... 300,000
Chicago " " 3,000,000	"..... 1,250,000	"..... 1,500,000	Wheeling, U.S.A. 500,000
"..... 1,000,000	"..... 1,250,000	"..... 2,000,000	Walker..... 300,000
"..... 1,000,000	"..... 1,250,000	Newport, U.S.A. 430,000	Westgate..... 100,000
Chemnitz..... 1,000,000	"..... 1,250,000	Newmarket..... 150,000	Wilmington, U.S.A. 500,000
Crewe..... 1,250,000	"..... 1,250,000	Newark, U.S.A. 680,000	Windsor, N. S. W..... 100,000
Colonial Gas Works Co..... 100,000	"..... 1,250,000	Northfleet..... 200,000	Wolverton..... 100,000
Cadiz..... 300,000	"..... 2,500,000	New York, U.S.A. 2,000,000	Wellington, N. Z..... 250,000
Charlottenburg..... 600,000	"..... 2,500,000	Nice..... 600,000	Whitchurch..... 175,000
Dudley..... 750,000	Silvertown..... 1,000,000	Newcastle, N. S. W..... 200,000	Washington, U.S.A. 2,000,000
Driffield..... 100,000	Bromley..... 2,000,000	Numea..... 100,000	Wallasey..... 750,000
Dukenfield..... 500,000	"..... 1,500,000	Namur..... 250,000	Weimar..... 150,000
Dover..... 750,000	"..... 1,500,000	Newark..... 350,000	Wurzen..... 200,000
"..... 1,000,000	"..... 1,500,000	Oldbury..... 500,000	Worcester, U.S.A. 750,000
Deal..... 200,000	"..... 2,000,000	Otley..... 200,000	Yeaton..... 500,000
Derby 1,500,000	"..... 1,500,000	Oswestry..... 250,000	Yeovil..... 250,000

SOLE AGENT FOR WESTERN HEMISPHERE,

GEO. SHEPARD PAGE, 69 WALL STREET, NEW YORK

THE UNITED GAS IMPROVEMENT CO.

DREXEL BUILDING, PHILADELPHIA.

OFFICERS:

WILLIAM W. GIBBS, President.

GEORGE PHILLER, Vice-President.

SAM'L T. BODINE, Gen'l Manager.

RANDAL MORGAN, Gen'l Counsel.

EDWARD C. LEE, Sec'y and Treas.

ALEX. C. HUMPHREYS, Gen'l Supt.

WALTON CLARK, Ass't Gen'l Supt.

H. H. EDGERTON, Chem. and Eng'r.

DIRECTORS:

GEORGE PHILLER,

THOMAS DOLAN,

HENRY C. GIBSON,

WM. T. CARTER,

WILLIAM G. WARDEN,

SAM'L T. BODINE.

BUILDERS, LESSEES AND PURCHASERS OF

✻ GAS WORKS. ✻

Orders solicited from Large Cities, Small Towns, Mills, Institutions, from all who want more Light for Less Money.

NATIONAL GAS LIGHT AND FUEL COMPANY,

No. 218 La Salle Street, Chicago.

THE SPRINGER SYSTEM

OF

Fuel and Illuminating Water Gas Works.

REFERENCES.

People's Gas Lt. & Coke Co..Chicago, Ill.
Illinois Light, Heat & Power

Co.....Chicago, Ill

Elgin National Watch Co...Elgin, Ill.

C. R. I. & P. R. R. Shops..Chicago, Ill.

Decatur Gas Lt & Coke Co..Decatur, Ill.

Niles Gas Light Co.....Niles, Mich.

Newton Illuminating Co...Newton, Kansas.

Wellington Light & Heat Co..Wellington, Kansas.

Chippewa Falls Gas Lt. Co..Chippewa Falls, Wis.

Elkhart Gas Lt & Coke Co..Elkhart, Ind.

Madison City Gas Light Co.Madison, Wis.

South Bend Gas Light Co..South Bend, Ind.

Sheboygan National Gas Co.Sheboygan, Wis.

Salina Gas Light Co.....Salina, Kansas.

The Rathbun Co.....Deseronto, Prov.Ont.

Jefferson City Gas Lt. Co..Jefferson City, Mo.

Mankato Gas Light Co.....Mankato, Minn.

Lima Gas Light Co.. ..Lima, Ohio.

Minneapolis Gas Light and

Coke Co.....Minneapolis, Minn.

Bellevue Water and Fuel { Bellevue, Campbell
Gas Light Co..... } County, Ky.

Bucyrus Gas Lt. & Fuel Co.Bucyrus, Ohio.

Morris Gas Co.....Morris, Ill.

Los Angeles Gas Co.....Los Angeles, Cal.

San Diego Gas Fuel & Elec-

tric Lt. Co.....San Diego, Cal.

Sioux Falls Gas Co.....Sioux Falls, Dak.

Dakota Gas and Fuel Co..Grand Forks, Dak.

St. Johns Mutual Gas Co...St. Johns, Mich.

Stillwater Gas Light Co...Stillwater, Minn.

St. Paul Gas Light Co.....St. Paul, Minn.

Emporia Electric and Gas

Light Co.....Emporia, Kas.

Van Wert Gas Light Co...Van Wert, Ohio.

Lansing Gas Light Co.....Lansing, Mich.

San Francisco Gas Lt. Co...San Francisco, Cal.

Shelbyville Gas Light Co...Shelbyville, Ind.

Great Falls Gas Light Co.. Great Falls, N. H.

Belleville Gas Co.....Belleville, Ontario

Rochester Lt. and Fuel Co..Rochester, Minn.

Northwestern Gas Light and

Coke Co.....Evanston, Ill.

Lincoln Gas Light Co.....Lincoln, Neb.

Davenport Gas Light Co...Davenport, Iowa.

Municipal Gas Co.....Albany, N. Y.

Alliance Gas Light Co.....Alliance, Ohio.

New Gas Light Co.....Janesville, Wis.

Chicago Gas Lt. & Coke Co., Chicago, Ill.

Joliet Gas Co.....Joliet, Ills.

Superior Light & Fuel Co..Superior, Wis.

Kewanee Gas Light Co...Kewanee, Ill.

Aberdeen Light & Fuel Co..Aberdeen, So. Dak.

Pierre Light and Fuel Co..Pierre, So. Dak.

*Standard Gas Light Co...New York City.

*Carlinville Gas Light Co..Carlinville, Ill.

* Building.

GUARANTEED ESTIMATES of Cost of Gas Furnished on Application.

GASHOLDER TANK CONSTRUCTION, ETC.

Gas Companies and others about to erect Gasholders will find it profitable to consult
W. C. Whyte, who for over 30 years has made a specialty of

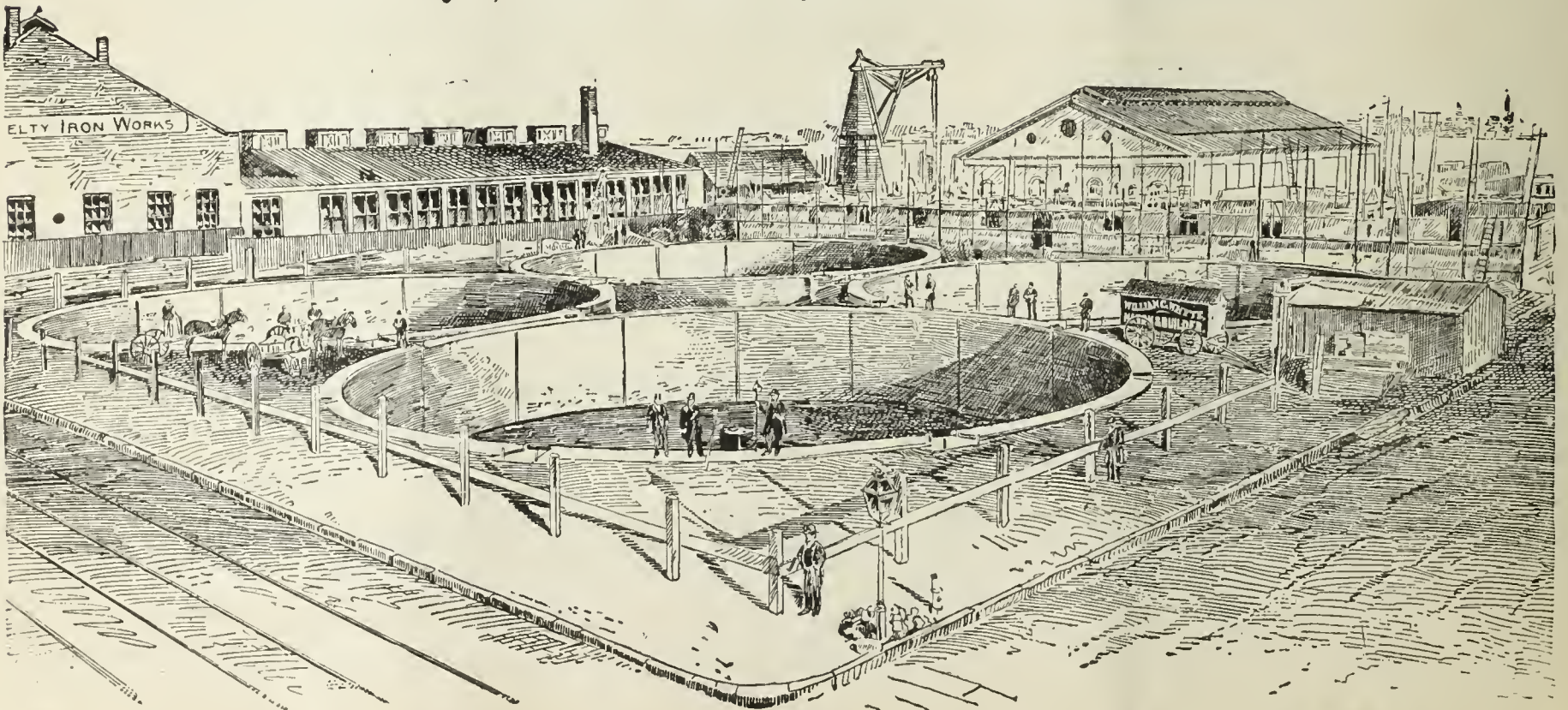

Tank Excavation and Mason Work.

Fifty Tanks now in operation show the sort of work done. Address

W. C. WHYTE, - No. 15 Cortlandt Street, N. Y. City.

CONNELLY & CO.,

SOLE MANUFACTURERS OF THEIR PATENTED SPECIALTIES.

"IRON SPONGE." Saves money, saves labor, and is the most efficient purifying agent ever offered as a substitute for lime. Now used *in every State in the Union*, and purifying daily over *thirty-five million cubic feet*. Should be used in every gas works. Its own saving will pay for it many times over.

AUTOMATIC GOVERNOR. Has been on the market but *three years*, and in that time has been introduced *more generally* than any invention ever designed for use in gas works. Over *two hundred* of them now in use. Sensitive; reliable; perfectly automatic; reduces leakage; satisfies consumers, and gives great relief to the Manager. No gas works is *complete* without one of these machines.

STEAM JET EXHAUSTER. Designed particularly for small works. Combines Exhaust Tube, Steam Governor Gas Compensator, and Bye-Pass Valves in the most compact form possible; occupies but little space; uses very little steam; operated by ordinary workmen; saves formation of carbon in retorts; increases yield 10 to 15 per cent. Specially adapted for *mixing air* with oil gas. *No works* too small to use them profitably.

Prices given on all our specialties *delivered at any point in the United States*. Correspondence solicited.

CONNELLY & CO., No. 111 Broadway, New York City.

WILBRAHAM GAS EXHAUSTER

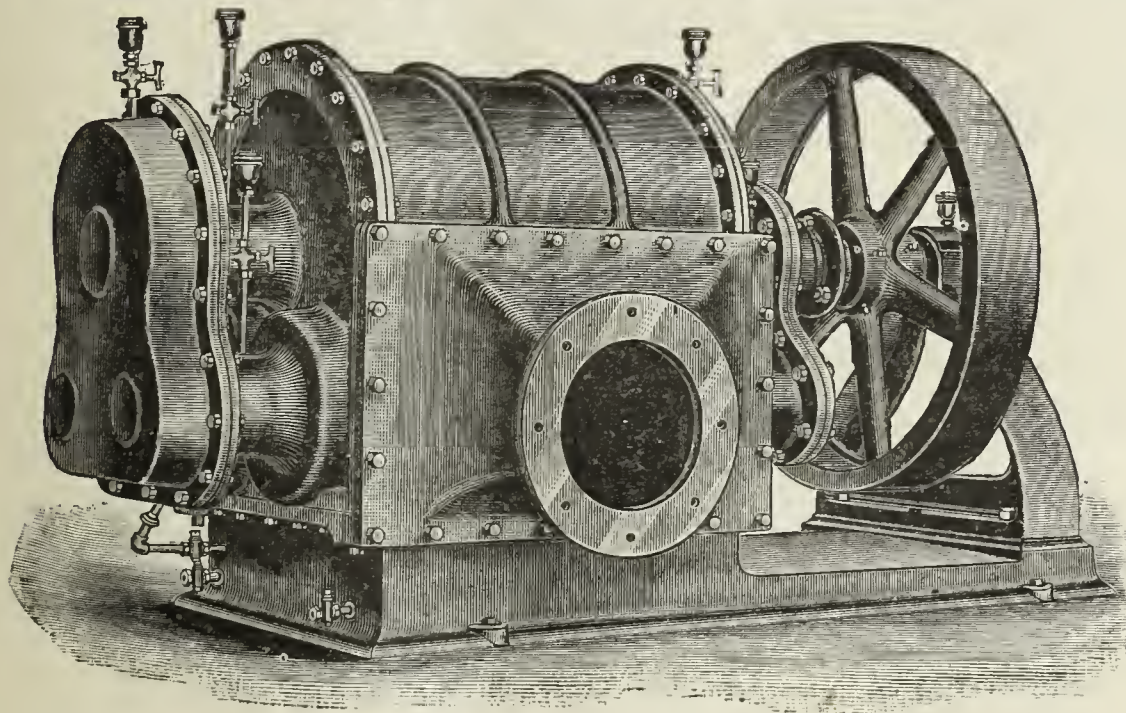

WILBRAHAM BROS.,
PHILADELPHIA, PA.

JARVIS ENGINEERING CO.,

61 Oliver St., Boston, Mass.

CONTRACTORS FOR ERECTING

COMPLETE STEAM OUTFITS FOR ELECTRIC LIGHTING STATIONS.

Steel Boilers set with Jarvis Pat. Boiler Setting

To burn **COKE SCREENINGS** for Fuel.

ARMINGTON & SIMS CO. ENGINES,

Belting direct to Dynamos, without using Shafting.

SEND FOR CIRCULARS.

REFERENCES.—Charlestown Gas & Electric Light Co., Charlestown, Mass.; Schenectady Gas & Electric Light Co., Schenectady N. Y.; Brookline Gas Co., Brookline, Mass.

Practical Electric Lighting

By A. BROMLEY HOLMES, A.M.I.C.E.

With 87 Illustrations. Third Edition. Price, \$1.00.

Electric Light Primer.

By CHARLES L. LEVEY.

A simple and comprehensive Digest of all the most important facts connected with the running of the Dynamo and Electric Lights, with Precautions for Safety, etc.

Price, 50 cents.

A. M. CALLENDER & CO., 42 Pine St., N. Y.

(Patented.)

IMPORTANT!

(Patented)

NEW SOLVENT FOR GAS PIPE DEPOSITS.

Economical and Effective.

MAAS & WALDSTEIN, 44 Trinity Place and 81 Greenwich St., N. Y.

Gasholder Tanks & Gas Works Masonry Complete.

PLANS PREPARED AND ESTIMATES FURNISHED AT SHORT NOTICE.

J. P. WHITTIER, - - 499 Wythe Av., Brooklyn, N. Y.



CHAPMAN VALVE MANUFACTURING CO.,

MANUFACTURERS OF

Valves and Gates for Gas, Ammonia, Water, Etc.

Also, Cate Fire Hydrants With and Without Independent Nozzle Valve. All Work Guaranteed.

WORKS & GEN'L OFFICE:
Indian Orchard, Mass.

TREASURER'S OFFICE:
72 Kilby & 112 Milk Sts, Boston, Mass.

LUDLOW VALVE MFG. CO.

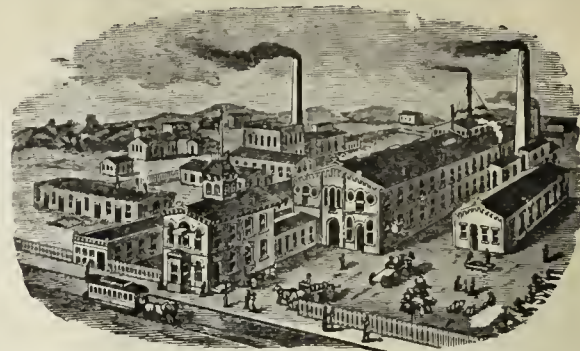

OFFICE AND WORKS,

938 to 954 River Street and 67 to 83 Vail Av.,
TROY, N. Y.

Parson's Steam Blower,

FOR IMPROVING BAD DRAUGHT IN BOILERS, AND FOR BURNING BREEZE OR OTHER WASTE MATERIAL.

PARSON'S TAR BURNER,

FOR UTILIZING COAL TAR AS FUEL.

PARSON'S AIR JET TUBE CLEANER,

FOR CLEANING BOILER TUBES.

These devices are all first-class. They will be sent to any responsible party for trial. No sale unless satisfactory. Manufactured by the WATERTOWN STEAM BLOWER COMPANY.

H. E. PARSON. Supt., 33 & 35 Liberty St., N.Y

MILLS' REVERSIBLE LIME TRAY,

AND

WOODWORK

Of Every Description

NEEDED BY GAS WORKS.

SEND FOR CIRCULAR AND PRICE LIST TO

BARTLETT, HAYWARD & CO.,

Pratt and Scott Streets, Baltimore, Md.

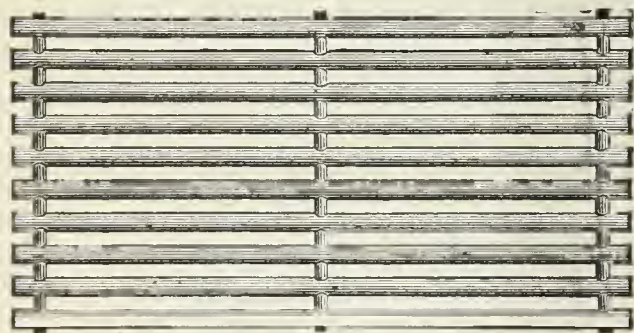

VAN DUZEN GAS & GASOLINE ENGINE

OPERATED with COAL and OTHER MANUFACTURED GASES AND GASOLINE.

RELIABLE AND ECONOMICAL.

Fully Warranted

VAN DUZEN

Gas & Gasoline Engine Co.
49 E. 2d St., Cincinnati, O.

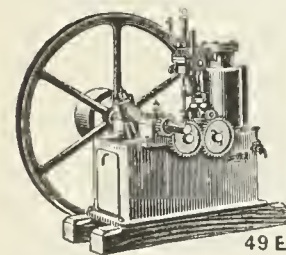

A. MacKinnon Machine Co., Agts., 22 Warren St., N.Y.

The Management of Small Gas Works.

BY C. J. R. HUMPHREYS.

Price, \$1.

Orders to be sent to A. M. CALLENDER & CO.,

42 PINE STREET, NEW YORK.

Hydraulic Main Dip Regulators, also Check Valves, Foot Valves, Yard-wash and Fire Hydrants. Send for Circulars.

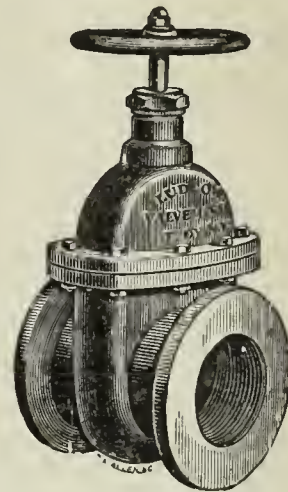

Valves.—Double and Single Gate, 1/2 in. to 48 in., outside and inside Screws. Indicator, etc., for Gas, Water, Steam, and Oil. Send for Circulars.

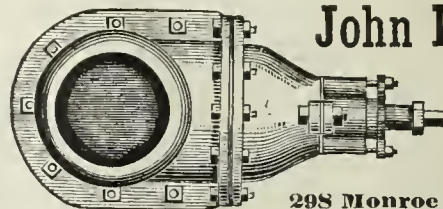

John McLean

Manufacturer

GAS VALVES.

298 Monroe Street, N. Y.

SPECIAL TRAYS FOR IRON SPONGE OR OXIDE OF IRON.

CHURCH'S TRAYS A SPECIALTY.

REVERSIBLE-STRONGEST-MOST DURABLE-MOST EASILY REPAIRED.

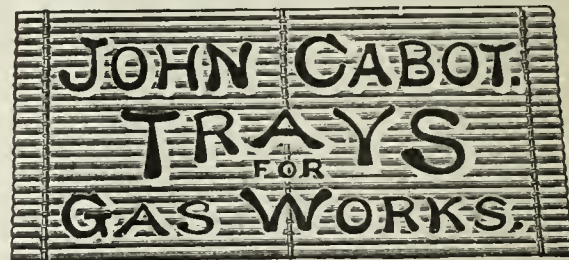

306-310 ELEVENTH AVENUE, NEW YORK.

WE ALSO MAKE THE CHEAPEST AND STRONGEST REVERSIBLE BOLTED TRAYS IN THE MARKET.

THE CLERK GAS ENGINE CO.,

Main Office, 1012, 1014, 1016, 1018 Filbert St., Philadelphia, Pa.

WM. W. GOODWIN, Prest.

E. STEIN, Sec.

S. LEWIS JONES, Asst. Sec.

A. J. DOTY, Supt.

The utility and convenience of the Gas Engine being no longer an open question, it only remains now for intending purchasers to select the BEST. We claim for the CLERK GAS ENGINE that it is equal to any other manufactured as regards steadiness in running, simplicity, and ease of keeping in repair, and that it gives the greatest amount of power for the least money (both in first cost and expense of running) of any engine made. In support of this claim we refer to the test of the Gas Engines made under the direction of the American Institute of New York, in December, 1885, and heretofore published in these columns. These engines are especially adapted for continuous running under heavy loads, and we can refer to Engines which have run 22 hours a day for months at a time

Made in Sizes of 5 10 15 20, and 25 Horse Power. All Engines Guaranteed for One Year.

GAS STOVES.

GAS METERS.

GAS STOVES.

THE AMERICAN METER CO.,

MANUFACTURERS OF

GAS METERS, Station Meters,

METER PROVERS, PHOTOMETERS,

PRESSURE GAUGES OF ALL KINDS,



Standard 3 Diaphragm Dry Meter

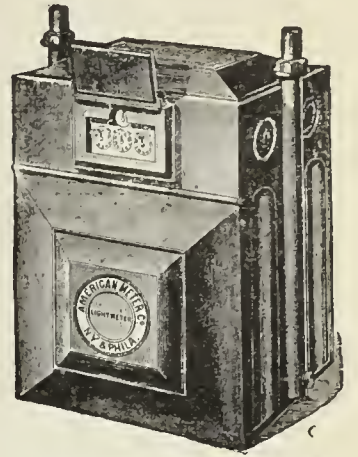

Standard 2 Diaphragm Dry Meter.

AND

Apparatus for Testing the Quantity and Quality of Gases.

GAS STOVES FOR HEATING AND COOKING

Sole Agents in the United States for

Verity's Patent Gas Fires.

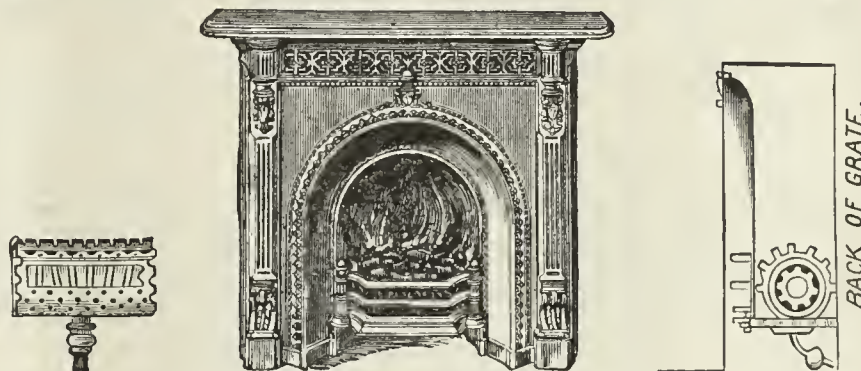

Circulars and Price Lists on Application.

MANUFACTORIES,

508 to 514 West Twenty-second St., N. Y.

Arch and Twenty-second St., Phila

Nos. 244 & 246 North Wells Street, Chicago, Ill.

AGENCIES,

No. 177 Elm Street, Cincinnati, Ohio.

No. 222 Sutter Street, San Francisco, Cal

No. 810 North Second Street, St. Louis, Mo.

STOVE SHOW ROOMS, No. 242 Sixth Avenue, New York City

RETORTS AND FIRE BRICK.

RETORTS AND FIRE BRICK.

RETORTS AND FIRE BRICK.

J. H. CAUTIER & CO.,

CORNER OF

GREENE AND ESSEX STREETS,
JERSEY CITY, N. J.

MANUFACTURERS OF

**Clay Gas Retorts,
Gas House Tiles,
Fire Bricks, Etc. Etc.**

**Ground Clay, Fire Brick and
Fire Sand in Barrels,**

J. H. GAUTIER. C. E. GREGORY. C. E. GAUTIER.

BROOKLYN

Clay Retort & Fire Brick Works,
(EDWARD D. WHITE & CO.)

Manufacturers of Clay Retorts, Fire Brick,
Gas House and other Tile.

VAN DYKE, ELIZABETH, RICHARDS & PARTITION STS.
Office, 88 Van Dyke St., Brooklyn, N. Y.

LACLEDE FIRE BRICK MFG. CO.,

MANUFACTURERS OF

Fire Brick, Gas Retorts,

AND

ST. LOUIS STANDARD SEWER PIPE.

Blast Furnace and Cupola Linings, every description of Fire
Clay Material, Fire Clay Flue Linings, Chimney Tops
Dry Milled and Crude Fire Clays, etc.

OFFICE AND DEPOT

901, 903, and 905 Pine Street,
ST. LOUIS, MO.

ESTABLISHED IN 1845.

B. KREISCHER & SONS,

OFFICE FOOT OF HOUSTON ST., E.R., N. Y.

Gas Retorts,

TILES, FIRE BRICK.

AND EVERYTHING IN THE FIRE CLAY LINE.

MANHATTAN

FIRE BRICK & ENAMELLED CLAY

RETORT WORKS

ADAM WEBER.

CLAY GAS RETORTS

AND RETORT SETTINGS

FIRE BRICKS, TILES, ETC.,

Office and Works, 15th Street and Avenue C., N. Y.



Works,

LOCKPORT STATION, PA.

—ESTABLISHED 1864.—

JAMES GARDNER, JR.,

Successor to WILLIAM GARDNER & SON.

Office, Rooms 19 & 20, Lewis Block,
PITTSBURGH, PA, P. O. Box 373.

Fire Clay Goods for Gas Works.

H. A. NORTON, No. 4 CENTRAL STREET, BOSTON, MASS., Agent for the New England States.

GEO. C. HICKS,
Pres.

CHICAGO

CHAS. A. REED,
Sec. & Treas.

Retort and Fire Brick Co.,

MANUFACTURERS OF

Fire Clay Goods of all Kinds,

AND BEST QUALITY ONLY.

Regenerative Furnaces & Water Gas Goods.

45th St., Clark to La Salle, Chicago.

Parker-Russell

Mining and Mfg. Co.,

CITY OFFICE: { Me. mod-Jaccard Bldg., Rooms 307 & 308,
Broadway and Locust Street, St. Louis, Mo.

PROPRIETORS OF THE

OAKHILL GAS RETORT & FIRE BRICK W'KS

Our immense establishment is now employed almost entirely in
the manufacture of materials for

GAS COMPANIES.

We have studied and perfected three important points. Our re-
torts are made to stand changes of temperature, the strongest
heats of the furnace, and the abrasion of feeding and emptying.

We furnish and build Half-Depth or Full
REGENERATOR FURNACES

of different kinds and most approved styles.

Correspondence solicited.

THOS. SMITH, Pres.

AUGUST LAMBLA, Vice-Prest. & Supt.

BALTIMORE

RETORT & FIRE BRICK CO.

MANUFACTORY AT

LOCUST POINT, BALTIMORE, MD.

Clay Retorts, Blocks & Tiles,

FIRE BRICK, FIRE CLAY,

AND FIRE CEMENT.

Red and Buff Ornamental Tiles and Chim-
ney Tops. Drain and Sewer Pipe (from
2 to 30 inches). Baker Oven Tiles
12x12x2 and 10x10x2.

WALDO BROS., 88 WATER ST., BOSTON, MASS.

Sole Agents the New England States.

1889 DIRECTORY 1889

OF THE GAS LIGHT COMPANIES of the UNITED STATES & CANADA.

Price, \$3.00.

A. M. CALLENDER & CO., No. 42 Pine Street, N. Y. City.

HENRY MAURER & SON,

(ESTABLISHED 1856.)

**EXCELSIOR FIRE BRICK & CLAY
RETORT WORKS**

WORKS, Perth Amboy, N. J.

OFFICE, 418 to 422 East 23d St., N. Y.

**Clay Gas Retorts,
BENCH SETTINGS,
Fire Brick, Tiles, Etc.**

**FLEMMING'S
Generator-Gas Furnace**

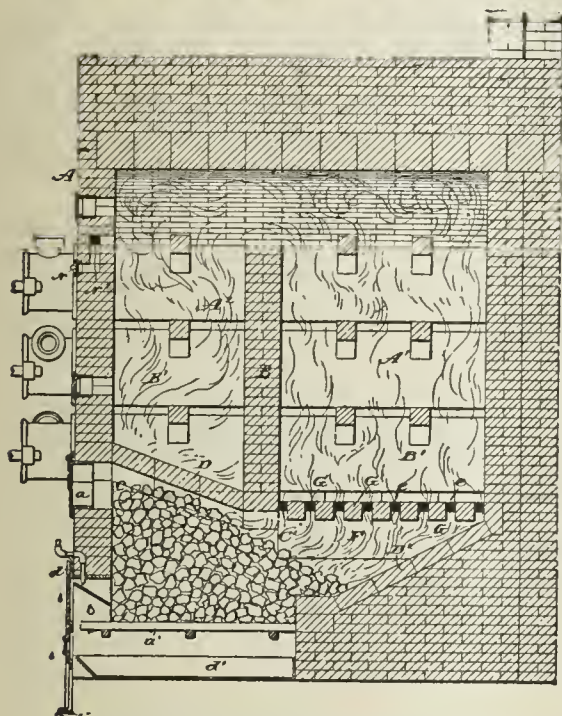

Materials furnished and Benches erected by

J. H. GAUTIER & CO., - Jersey City, N. J.

Address as above, or D. D. FLEMMING, Jersey City, N. J.

FRED. BREDEL,

CONTRACTOR FOR THE COMPLETE

Erection and Equipment of Gas Works.

SOLE PROPRIETOR OF THE

KLOENNE PATENTS

FOR NORTH AMERICA.

REGENERATIVE FURNACES.

(900 Retorts are now fired in America by the Kloenne-Bredel System.)

SELF-SEALING MOUTHPIECES.

(Over 800 Now in Use.)

Standard Condensers. Washer-Scrubbers.

TAR WASHERS FOR WATER GAS PLANTS.

(In use in the works of the Chicago Gas Lt. Co.)

GASHOLDERS.

Bredel's Automatic Gas Governor.

Refers, by permission, to Mr. Eugene Vanderpool, Newark, N. J.; Mr E. G. Cowdery, Milwaukee, Wis.; and Mr. Theo. Forstall, Chicago, Ills. For further information, address

FRED. BREDEL,

No. 208 East Seventeenth Street, N. Y. City.

COMPOUND Condensing or Non-Condensing.

18 SIZES, 5 to 500 H. P.

Not yet equaled by any form of Engine for
HIGH FUEL DUTY AND SIMPLICITY.

STANDARD 13 Sizes in Stock.
5 to 250 H. P.

3000 in use in all parts of the Civilized World.

JUNIOR 6 Sizes in Stock,
5 to 50 H. P.

An Automatic Engine cheaper than a Slide Valve.
WELL BUILT. ECONOMICAL. RELIABLE.

Over 300 Sold the First Year.

All the above built strictly to Gauge with
INTERCHANGEABLE PARTS.

REPAIRS CARRIED IN STOCK.

SEND FOR ILLUSTRATED CATALOGUES.

**WESTINGHOUSE
ENGINES**
The Westinghouse Machine Co.
PITTSBURGH, PA. U.S.A.

**SELLING DEPARTMENT IN THE
UNITED STATES.**

New York, 17 Cortlandt St. }
Boston, Hathaway Building, } Westinghouse,
Pittsburgh, Westinghouse Build'g, } Church, Kerr
Chicago, 156, 158 Lake St. } & Co.
Philadelphia, 608 Chestnut St. M. R. Muckle, Jr. & Co.

ST. LOUIS,

511 NORTH FOURTH ST.,

Westinghouse, Church, Kerr & Co.

Salt Lake City, 259 S. Main St. } Utah & Montana
Butte, Mont. 1. Granite St. } Machinery Co.
San Francisco, 21, 23 Fremont Street, Parke & Lacy Co.
Portland, Or. 33, 35 N. Front St. Parke & Lacy Mch. Co.
Charlotte, N. C. 36 College St. } The D. A. Tompkins Co.
Atlanta, Ga. 45 S. Prior St. }
Dallas, Tex. Keating Imp. & Machine Co.
Chattanooga, Tenn., G. E. James & Co.

Newbigging's Handbook for Gas Engineers and Managers.

The present (the fifth) edition marks an important advance on those that have gone before. Considerable additions have been made to the text, and much of it has been re-written and otherwise improved. It extends to 524 pages, and contains 193 illustrations. Price, Cloth, \$6.00.

A. M. CALLENDER & CO., - - - - No. 42 Pine Street, N. Y. City.

GAS AND WATER PIPES.

GAS AND WATER PIPES.

ENGINEERS.

SAM'L R. SHIPLEY, Pres.
HENRY B. CHEW, Tre.

JAS. P. MICHELLON, Sec.
WM. SEXTON, Supt.

P. D. WANNER, Chairman. A. H. MELLERT, Mangr. of Wks.
R. B. KINSEY, Secretary. F. A. KNOPP, Treasurer.

GLOUCESTER IRON WORKS,
GLOUCESTER CITY, N. J.



Cast Iron Gas & Water Pipes, Stop Valves, Fire Hydrants, Gasholders. &c.

Office, Rooms 61 and 63 Bullitt Building, 131 S. 4th St., Phila., Pa.

WARREN FOUNDRY AND MACHINE CO.,

Established 1856. Works at Phillipsburgh, N. J.

New York Office, 160 Broadway.

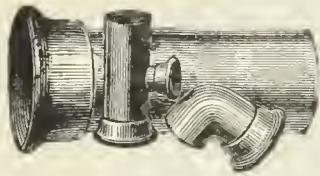

CAST IRON WATER AND GAS PIPE,

FROM TWO TO FORTY-EIGHT INCHES DIAMETER. ALSO, ALL SIZES OF

Flange Pipe for Sugar House and Mine Work. Branches, Bends, Retorts, etc., etc.

DENNIS LONG & COMPANY,

LOUISVILLE, KY.,



Manufacture Exclusively

CAST IRON GAS & WATER PIPE & SPECIAL CASTINGS
OF ALL SIZES.

King's Treatise on Coal Gas.

A standard text-book for the Engineers and Managers of Gas Works, and for all who are concerned or take an interest in the manufacture and distribution of Coal Gas, and in the utilization of the Secondary Products resulting therefrom; treating also of the Gas Engine, and of Gas Cooking and Heating Appliances.

In 3 Vols. Price per Vol., \$10. Sold either by Volume or in Sets.

A M. CALLENDER & CO., 42 Pine St., N. Y.

MELLERT FOUNDRY & MACHINE CO. Ltd.
and **READING FOUNDRY CO., Ltd.**
Reading, Pa.



Specials—Flange Pipe, Valves and Hydrants
Lamp Posts, Retorts, etc.

General Foundry and Machine Work.

JOHN FOX, Selling Agent. 160 Broadway, N.Y.

THE OHIO PIPE COMPANY,

MANUFACTURERS OF

Cast Iron Gas & Water Pipe,

BRANCH AND SPECIAL CASTINGS.

Gas-House Bench Castings, Hydraulics, Lamp Posts, Flange Pipe
and Specials, Architectural Castings, Building Columns,
Joists, Cellar Grates, Sash Weights, etc.

GENERAL FOUNDERS AND MACHINISTS.

Columbus, Ohio.

M. J. DRUMMOND,



SPECIAL CASTINGS AND LAMP POSTS.

Office, Corbin Building, 192 Broadway, N. Y.

EMAUS PIPE FOUNDRY.

DONALDSON IRON COMPANY. EMAUS, PA.



MANUFACTURERS OF

CAST IRON PIPE AND SPECIAL CASTINGS
FOR WATER AND GAS.

JOS. R. THOMAS,

No. 42 Pine Street, N.Y. City.

CONSULTING AND CONSTRUCTING

Gas Engineer and Contractor.

PLANS, SPECIFICATIONS, AND ESTIMATES
FURNISHED.

Contracts taken for all Appliances
required at a Gas Works,

Either for New Works or Extensions to Old Plants.

WM. MOONEY

(Successor to WM. FARMER)

No. 94 Liberty St., N. Y. City.

GAS ENGINEER AND CONTRACTOR FOR THE ERECTION
OF GAS WORKS, OR APPARATUS OF ANY
CAPACITY.

Plans and Specifications Furnished.

WM. GARDNER,
Gas Engineer,

Lewis Block, Room 20, Pittsburgh, Pa.

Those who intend to make alterations in existing gas plants, or who contemplate the erection of new works, will find it to their interest to open correspondence with the above. Plans made and estimates furnished.

ARTLETT, HAYWARD & CO.

Baltimore, Md.

Triple Double, & Single-Lift
GASHOLDERS.

Iron Holder Tanks.

ROOF FRAMES.

Cirders.

BEAMS.

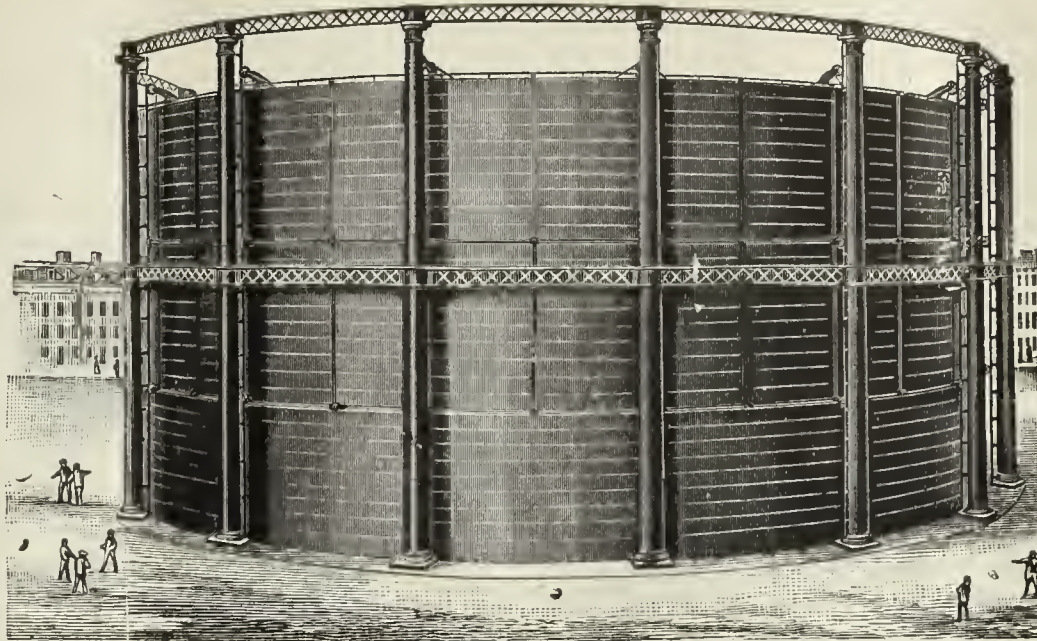

PURIFIERS.
—
CONDENSERS.
—
Scrubbers.
—
BENCH CASTINGS.
—
OIL STORAGE TANKS.
—
Boilers.

The Wilkinson Water Gas Process.

THIRTY-CANDLE, NON-CONDENSABLE, FIXED GAS. THE MOST SUCCESSFUL GAS PROCESS IN OPERATION.

Munich Regenerative Furnace, System Drs. Schilling & Bunte.

HAZELTON BOILERS.

Gas Works Designed and Constructed.

Pascal Iron Works. ESTABLISHED 1821. Delaware Iron Works.

MORRIS, TASKER & CO.,

INCORPORATED.

OFFICE, 224 SOUTH THIRD STREET, - - PHILADELPHIA, PA.

CONTRACTORS, BUILDERS, AND MANUFACTURERS OF

Gas, Water & Sugar Works

Bench Castings.

Condensers.

Scrubbers.

Purifiers.

Hyd. Carriages.

Iron Floors,

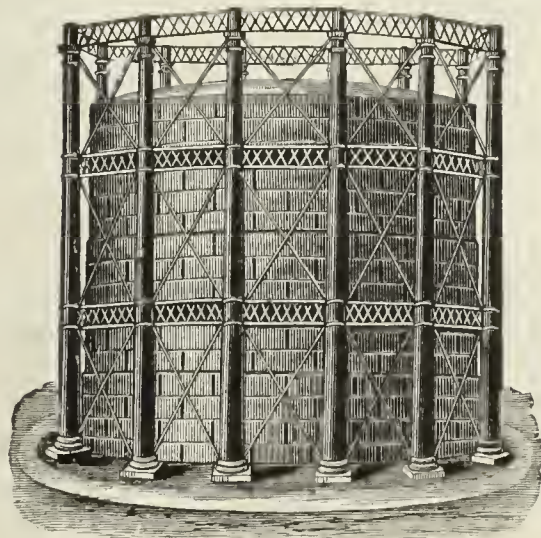

Iron Roofs.

Street Stops,

Valves, etc.

Stand-Pipes.

Water & Oil

Tanks, all Sizes.

Single, Double, and Triple-Lift Gas Holders.

SELF-SEALING RETORT LIDS. STAMPED STEEL RETORT LIDS.

Locomotive Water Columns, Filters, etc. Boiler Tubes, Wrought Iron Pipe & Fittings

Plans, Specifications and Estimates for all kinds of Machinery furnished on application.

Foundries & Works,
MILLVILLE, FLORENCE,
and CAMDEN, N. J.

R. D. WOOD & CO.,

Engineers,
Iron Founders,
and
Machinists.

400 Chestnut St., PHILADELPHIA, PA.

MANUFACTURERS OF

CAST IRON PIPE,

Gas Holders,

SINGLE, DOUBLE, AND TRIPLE LIFTS, WITH
OR WITHOUT WROUGHT IRON
OR STEEL TANKS.

PURIFIERS, CONDENSERS.

Scrubbers.

BENCH WORK.

Iron Floors and Roofs, Plate Girders.

Heavy Loam Castings.

HYDRAULIC WORK.

Lamp Posts, Valves, Etc.

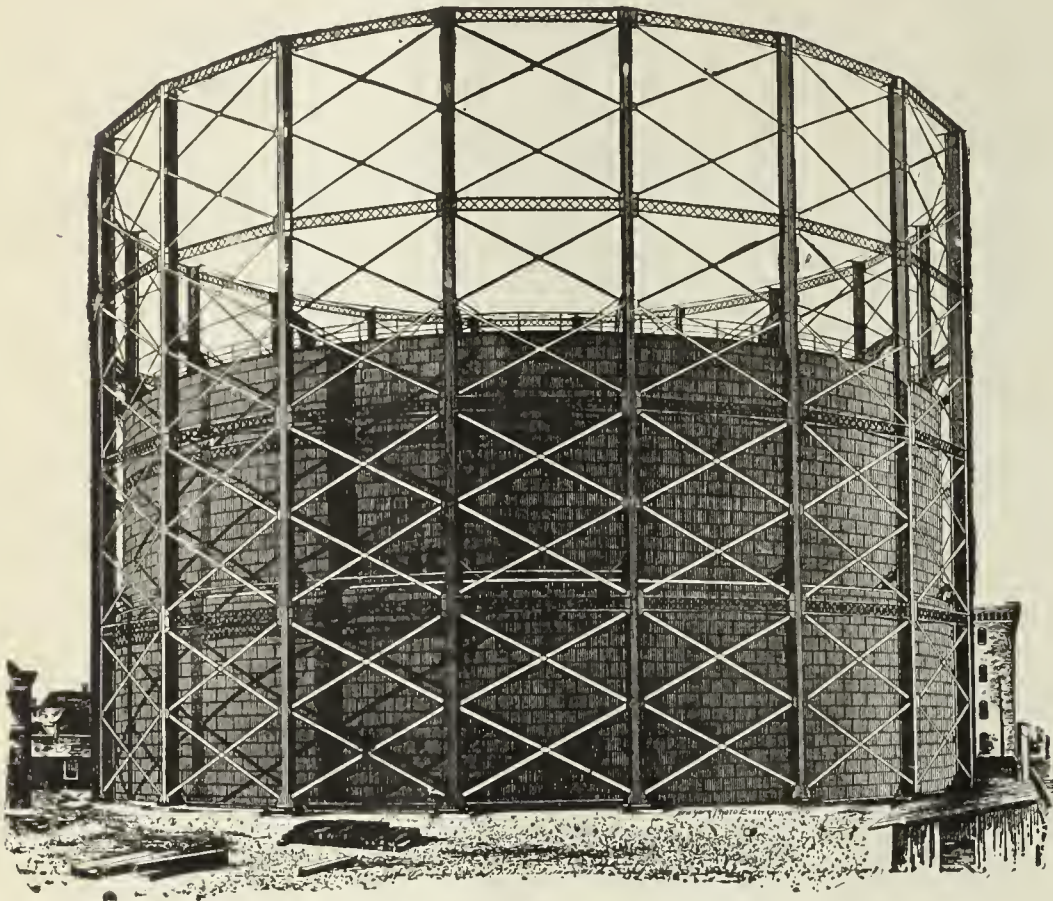

SMITH & SAYRE MFG. COMPANY,

G. G. PORTER, Prest.

245 Broadway, N. Y.

CHAS. W. ISBELL, Sec'y.

Machinery & Apparatus for Gas Works

Drawings, Plans, and Estimates Furnished for the Improvement, Extension, or Alteration of Gas Works, or for the Construction of New Works.

Mackenzie's Patent Rotary and Steam Jet Gas Exhausters, Governors, Compensators, Condensers, Washers, Scrubbers. Isbell's Patent Automatic Street Pressure Governor, Gas and Water Valves, Hydraulic Main Dip Regulator, Bench Castings, etc. Purifying Boxes and "Standard" Scrubbers, Isbell's Patent Self-Sealing Retort Doors.

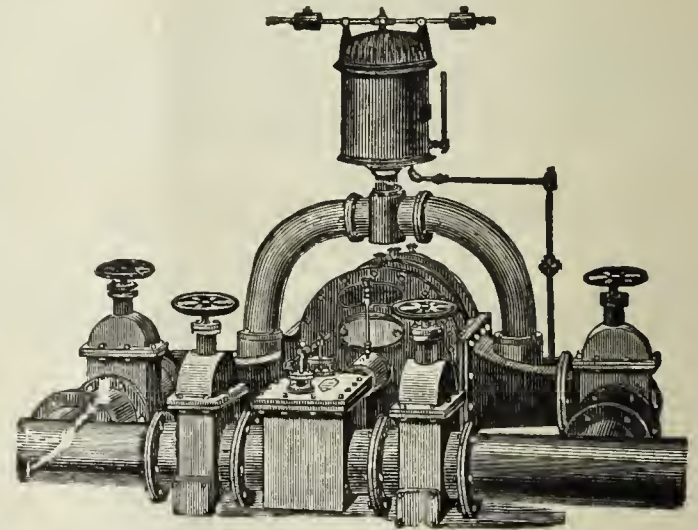

THE BRENNER SELF-SEALING RETORT DOOR.

Simple, Strong, and Durable.

CLOSES ABSOLUTELY TIGHT & IS LOCKED BY A CAM LEVER. ALL NECESSARY ADJUSTMENT FOR WEAR PROVIDED.

BUILT BY

SMITH & SAYRE MFG. CO.,

No. 245 Broadway, - - - New York City.

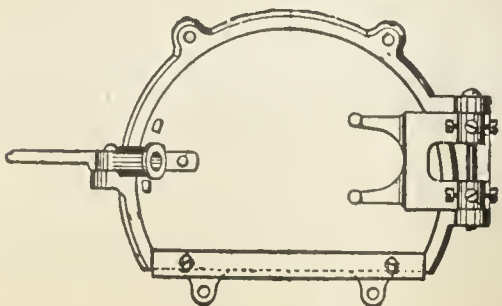

Brenner Self-Sealing Retort Door.

WILLIAM B. LUNDIE, Superintendent of the 42d Street Station of the Consolidated Gas Company, of New York, writes, under date of Jan. 4, 1889:

"We have 320 Brenner Self-Sealing Lids in use at this Station, built by the Smith & Sayre Mfg. Co. They require very little attention, and are the best of the kind that I have seen, giving entire satisfaction."

GAS WORKS APPARATUS AND CONSTRUCTION.

GAS WORKS APPARATUS AND CONSTRUCTION.

JAMES R. FLOYD & SONS,

(SUCCESSORS TO HERRING & FLOYD)

Oregon Iron Works,

W. 20th & 21st. Sts., bet. 10th & 11th Aves.,

NEW YORK CITY.

Engineers and Contractors

FOR THE

CONSTRUCTION OF GAS WORKS.

MANUFACTURERS OF

All Kinds of Castings and General Ironwork

FOR

GAS APPARATUS.

Bench Castings, Regenerative and Half Regenerative Furnace Castings.

Condensers, Scrubbers, Purifiers, Street Drips and Connections,

Valves,

Hydraulic Hoisting Purifier Carriage, Self-Sealing Retort Lids, Improved Valve Stand and Indicator,

Seller's Cement.

Plans, Specifications, and Estimates furnished for Construction of New or Alteration of Old Works.

CONTINENTAL IRON WORKS.

THOS. F. ROWLAND, Prest.

WARREN E. HILL and CHAS. H. CORBETT, V-Prests.

THOS. F. ROWLAND, JR., Sec. & Tr

P. O. Station G., BROOKLYN, N. Y.

ENGINEERS AND MANUFACTURERS OF

Gas Holders

CONDENSERS, SCRUBBERS, VALVES,

PURIFIERS, SELF-SEALING RETORT LIDS

Hydraulic Mains,

And all other articles connected with the manufacture and distribution of Gas.

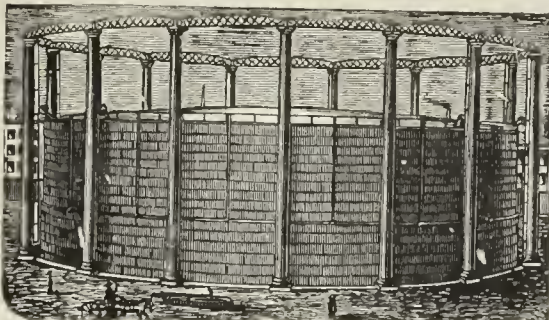

H. RANSHAW, Prest. & Mangr.

WM. STACEY, Vice-Prest.

T. H. BIRCH, Asst. Mangr.

R. J. TARVIN, Sec. & Treas.

STACEY MFG. CO.,

MANUFACTURERS OF

Single and Telescopic Gasholders,

IRON ROOFS, BRIDGES, LAMP POSTS,

Water and Oil Tanks, Coal Elevator Cars,

COKE CRUSHERS, BENCH CASTINGS,

And all kinds of Wrought and Cast Iron Work used in the erection of Coal and Oil Gas Works Rolling Mill Machinery and Heavy Castings a Specialty.

Foundry:

33, 35, 37 & 39 Mill Street.

Wrought Iron Works:

16, 18, 20, 22, 24 & 26 Ramsey Street:

Cincinnati, Ohio.

Bouton Foundry Co.,

FOUNDERS AND MACHINISTS,

CHICAGO, ILL.

Gas Works Apparatus,

PURIFIERS, CONDENSERS,

Bench Work

SPECIALS, LAMP POSTS,

SCRUBBERS,

Iron Roofs and Floors.

Plans and Estimates furnished for new works or extensions of old works.

1842. **DEILY & FOWLER,** 1889.

Laurel Iron Works.

Address, No. 39 Laurel Street, Philadelphia, Pa.

BUILDERS OF

GASHOLDERS,

Single and Telescopic.

HOLDERS BUILT 1884 TO 1888, INCLUSIVE:

Newport, R. I.	Long Island City, N. Y.	Port Chester, N. Y.	Malden, Mass.	West Chester, Pa. (2d)
Portland, Oregon.	Macon, Ga.	New Rochelle, N. Y.	Paducah, Ky.	Lancaster, Pa. (3d)
Allegheny, Pa. (2d.)	York, Pa.	Salem, N. J. (3d)	Norwich, Conn.	Fac ny, Pa. (two)
Atlanta, Ga. (2d.)	Chester, Pa.	Omaha, Neb. (2d)	Seattle, W. T.	Mount Vernon, N. Y.
N.Y. City (Central Gas Co)	Hazleton, Pa. (2d.)	Lynn, Mass. (2d)	San Diego, Cal.	Binghaunton, N. Y.
Lynchburg, Va. (2d.)	Staten Island, N. Y.	Little Rock, Ark.	Northern Gas Lt. Co., of	Concord, N. H.
Saylesville, R. I.	Sangerties, N. Y.	Irvington, N. Y.	New York, N. Y.	Dover, Del. (2d)
Rondout, N. Y.	Clinton, Mass. (Lan. Mills)	South Boston, Mass.	Westerly, R. I.	Calais, Me.
Atlantic City, N. J.	Chattanooga, Tenn.	Rye, N. Y. (2)	Williamantic, Conn	New London, Conn. (2d)
Augusta, Ga.	Galveston, Texas. (3d.)	Woodstock, Ont.	Montclair, N. J.	West Chester, N. Y.
Waltham, Mass. (2)	Omaha, Neb.	Malden, Mass.	Attleboro, Mass.	Bay Shore, L. I.
Mahanoy City, Pa.	Fort Plain, N. Y.	Staten Island, N. Y. (2d)	Santa Cruz, Cal.	Washington, D. C.
New Castle, Pa.	Brunswick, Ga.	Woodstock, Ont.	Erie, Pa. (2d)	

WM. HENRY WHITE,

No. 32 Pine Street, - - - New York City.

ENGINEER AND CONTRACTOR FOR THE

Erection and Extension of Gas, Water, and Electric Light Works.

SOLE REPRESENTATIVE OF THE

McILHENNY REGENERATOR FURNACE PATENTS

And the Martin Water Gas Process.

Edison Incandescent and American Arc Electric Light Plants Installed.

Correspondence with Gas Companies contemplating extending or improving their Plants respectfully invited. Plans and Estimates Furnished.

GAS COALS.

CANNEL COALS.

GAS ENRICHERS.

JAMES D. PERKINS.

PERKINS & CO.,

F. SEAVERNS.

228 & 229 Produce Exchange, New York.

Cable Address, "PERKINS, NEW YORK"

Post Office Box 3695, New York.

GENERAL SALES AGENTS FOR

The Youghioghenny River Coal Company's

OCEAN MINE YOUGHIOGHENY GAS COAL.

HON. W. L. SCOTT, Prest.

M. H. TAYLOR, Vice-Prest.

This Colliery is located at SCOTT HAVEN, PA., in the center of the Youghioghenny Gas Coal District, and produces the ONLY RELIABLE YOUGHIOGHENY COAL for gas purposes. (See Map on p. 87 of this JOURNAL, Feb. 16, '85.)

POINTS OF SHIPMENT,

Locust Point, BALTIMORE.

Pier No. 62, PHILADELPHIA.

Also, SOLE AGENTS for the

**BRECKENRIDGE CANNEL,
OF KENTUCKY.**

Within the past two years we have delivered this Cannel to over ONE HUNDRED COMPANIES IN THIRTY-THREE DIFFERENT STATES, and it is now in use in some of the large Gas Works

On the Continent and in South America,

where it successfully competes with the Australian Shale. It is the ONLY AMERICAN GAS CANNEL of sufficiently high grade to warrant EXPORTATION TO EUROPE AND SOUTH AMERICA, and it is the only economical substitute for OIL OR NAPHTHA. ONE GROSS TON will produce

10,000 Cubic Feet of 75 Candle Gas,	} equal to {	750,000 Candle Feet of Gas, and 26 Bushels of merchantable Coke weighing 900 Pounds
or 12,500 " " 60 " "		
or 15,000 " " 50 " "		

This is the ONLY GAS CANNEL that will produce a REALLY MERCHANTABLE COKE. It can be delivered in parcels of one carload or more to any point in the United States or Canada. Cargo shipments of any size required can be made from NEW YORK, PHILADELPHIA, BALTIMORE, or NEWPORT NEWS. Samples will be sent and particulars of price, etc., forwarded upon application to above address.

JAMES & WILLIAM WOOD,
Gas and Cannel Coal Contractors,

No. 40 St. Enoch Sq., Glasgow. No. 2 Talbot Court, London.

Proprietors of the BATHVILLE COLLIERIES (which produce the celebrated BOGHEAD CANNEL), Shields, Shieldmuir, Drumpeller, and other Collieries. This Firm offer

STANDARD CANNELS,

Unequaled as Gas Enrichers.

Also, WEST FAIRMONT GAS COAL, of W. Va.

Analyses, prices, and all further information furnished on application to

Agency for U. S., Room 93, Nos. 2 & 4 Stone St., N.Y. City.

The Standard Oil Company,
REFINERS OF**NAPHTHA AND GASOLINES.**

ALSO MANUFACTURERS OF

A Special Grade of Naptha for
Gas Companies**FOR ENRICHING COAL GAS.**

Correspondence solicited.

No. 43 Euclid Avenue, Cleveland, Ohio.

To Gas Companies.

We make to order CAP BURNERS to burn any amount under a stated pressure. Send for samples.

Also, SERVICE CLEANERS, DRIP PUMPS, and STREET MAIN PROVING APPARATUS.

C. A. GEFROER,

248 N 8th Street, Phila., Pa.

COKE CRUSHERS.

GAS COALS.

GAS COALS.

Newburgh Orrel Coal and Coke Co.

MINERS AND SHIPPERS OF

STEAM, SMITHING, AND GAS COALS,
Foundry and Crushed Coke.

Home Office, 33 S. Gay Street, Baltimore, Md.

J. HARRY LEE, President.

Shipping Wharves, Locust Point, Baltimore.

The Despard Gas Coal Co.,

MINERS AND SHIPPERS OF

DESPARD GAS COAL,

AND MANUFACTURERS OF

COKE.

MINES, Clarksburg, Harrison Co., W. Va.

WHARVES, Locust Point, Baltimore, Md.

OFFICE, 225 E. German St., " "

ROUSSEL & HICKS, } AGENTS. } BANGS & HORTON,
71 Broadway, N. Y. } 60 Congress St., Boston.

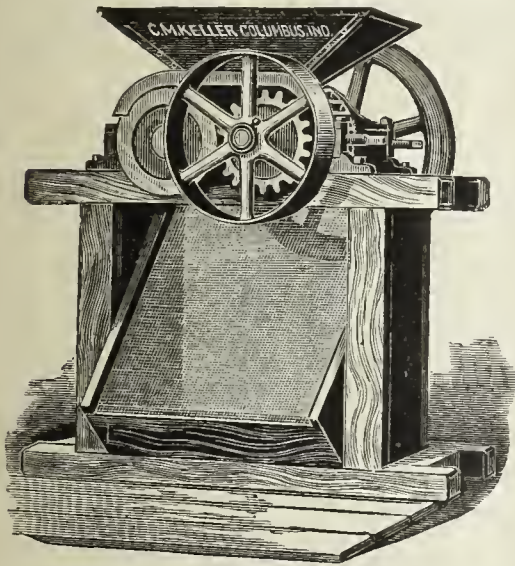

Keller's Adjustable Coke Crusher

SIMPLE, STRONG, AND DURABLE.

C. M. Keller, Sec. & Supt. Gas Lt. & Coke Co. Columbus, Ind.

Correspondence Solicited.

King's Treatise on Coal Gas.

The most complete work on Coal Gas ever published.

Three Vols. Bound, \$30.

BOOKS.

DISTILLATION OF COAL TAR AND
AMMONIACAL LIQUOR.

By GEORGE LUNGE. Price \$12.50.

A TREATISE ON THE COMPARATIVE
COMMERCIAL VALUES OF GAS
COALS AND CANNELS.

By DAVID A. GRAHAM. 8vo., Cloth. Price \$3.

Orders for these books may be sent to this office.

A. M. CALLENDER & CO.,

42 Pine St., N. Y. City

THE
PENN GAS COAL CO.

OFFER THEIR

Coal, Carefully Screened & Prepared for Gas Purposes.

Their Property is located in the Youghiogheny Coal Basin, near Irwin and Penn Stations on the Pennsylvania Railroad, and on the Youghiogheny River.

Principal Office:

209 SOUTH THIRD STREET, PHILA., PA.

Points of Shipment:

Pennsylvania Railroad Piers; Greenwich Wharves, Delaware River; Pier No. 1 (Lower Side), South Amboy, N. J.

Chesapeake & Ohio Railway Coal Agency,

FOR THE SALE OF THE

Superior Kanawha Gas Coals, Cannelton Cannel,
Also, SPLINT AND STEAM COALS,

From the Kanawha and New River Regions, on the line of the Chesapeake & Ohio R'way.

C. B. ORCUTT, General Agent, - - No. 1 Broadway (Room 217) New York City.

FRANCIS H. JACKSON, Prest.

EDMUND H. MCCULLOUGH, V.-Prest.

CHAS. F. GODSHALL, Treas.

H. C. ADAMS, Sec.

THE WESTMORELAND COAL CO.

Chartered 1854.

Mines situated on the Pennsylvania and the Baltimore and Ohio Railroads, in Westmoreland County, Penn.

POINTS OF SHIPMENT:

PHILADELPHIA, BALTIMORE, SOUTH AMBOY, N. J.,
WATKINS (SENECA LAKE), N. Y.

Since the commencement of operations by this Company its well-known Coal has been largely used by the Gas Companies of New England and the Middle States, and its character is established as having no superior in gas-giving qualities, and in freedom from sulphur and other impurities.

Principal Office, 224 South 3d St., Phila., Pa.

The American Gas Engineer
and Superintendent's Handbook.

By WILLIAM MOONEY.

Consisting of Rules, Reference Tables, and Original Matter
Pertaining to the Manufacture, Manipulation, and
Distribution of Illuminating Gas.

350 Pages, Full Gilt Morocco.

\$3.00.

A. M. CALLENDER & CO., 42 Pine St., N. Y.

GAS METERS.

GAS METERS.

GAS METERS.

ESTABLISHED 1859.

JOHN J. GRIFFIN & CO.,

Nos. 1513, 1515, 1517, & 1519 Race St., PHILADELPHIA.
 No. 52 Dey Street, NEW YORK. No. 75 North Clinton Street, CHICAGO.

Manufacturers of Meters for Measuring Gas

IN ANY VOLUME.

EXPERIMENTAL APPARATUS FOR QUANTITATIVE AND QUALITATIVE ANALYSIS.

Provers, Gauges, Registers, Etc.

Careful and Prompt Attention paid to the Repairing of all kinds of Meters and Apparatus.

Estimates Cheerfully Furnished.



Dry Gas Meters.

With 40 years' experience and the best facilities for manufacturing, is enabled to furnish reliable work and answer orders promptly.

NATHANIEL TUFTS,

No. 153 Franklin Street, Boston, Mass.,

MANUFACTURER OF

DRY GAS METERS.

Station Meters of any Capacity.

Test and Experimental Meters, Pressure Registers, Pressure Gauges, Pressure and Vacuum Gauges.

METER PROVERS, PHOTOMETERS, STREET LANTERNS, ETC., ETC.

Patent Cluster Lanterns for Street Illumination.

HAROLD J. BELL.

BELL & JONES,

S. LEWIS JONES.

No. 12 North Ninth Street, Philadelphia, Pa. Works at Royersford, Pa.

MANUFACTURERS OF

GAS METERS, STATION AND EXPERIMENTAL METERS,

Meter Provers, Pressure Gauges, and All Other Gas Appliances in Our Line.

WE REPAIR ALL KINDS AND MAKES OF METERS, AND THE WORK GUARANTEED.

High Pressure Meters for Natural Gas, in Iron Cases, guaranteed to stand 300 lbs. Pressure.
 Gas Cooking and Heating Stoves, Hot Plates, Cake Griddles, Waffle Bakers, Boiling Stoves, Laundry and Tailors' Iron Heaters. Hotel and Cafe Ranges a Specialty.

Correspondence Solicited.

Estimates Furnished.

SCIENTIFIC BOOKS.

All books forwarded by express, upon receipt of price; if sent by mail, postage must be added to price given. We take pains in forwarding any other Works desired. Remittances by check, draft, or P.O. money order.

KING'S TREATISE ON THE MANUFACTURE OF COAL GAS. Three vols; \$10 per vol.
 GAS MANUFACTURE, by WILLIAM RICHARDS. 4to., with numerous Engravings and Plates, in Cloth binding. \$12.
 TECHNICAL GAS ANALYSIS. \$3.00.
 GAS CONSUMER'S GUIDE. \$1.
 A GUIDE TO GAS LIGHTING. 40 cents.
 GAS MEASUREMENT AND GAS METER TESTING, by F. W. HARTLEY. \$1.60.
 GAS CONSUMER'S HANDBOOK, by WILLIAM RICHARDS, C.E.: 18mo., Sewed. 20 cents.
 A PRACTICAL TREATISE ON GAS AND VENTILATION, with Special Relation to Illuminating, Heating, and Cooking by Gas, by E. E. PERKINS. \$1.25.
 PRACTICAL TREATISE ON HEAT, by THOMAS BOX. Second edition. \$5.

COAL; ITS HISTORY AND USE, by PROF. THORPE. \$3.50.
 THE GAS WORKS OF LONDON, by COLBURN. 50 cents.
 THE GAS FITTER'S GUIDE, Showing the Principles and Practice of Lighting with Coal Gas, by JOHN ELDRIDGE. 40 cents.
 MUNICIPAL LIGHTING, by F. H. WHIPPLE. \$1.
 GAS WORKS, AND MANUFACTURING COAL GAS, HUGHES. \$2.20.
 THE MANAGEMENT OF SMALL GAS WORKS, by C. J. R. HUMPHREYS. \$1.
 MANUAL FOR GAS ENGINEERING STUDENTS, by D. IEE. 40 cents.
 HOW TO MANAGE GAS, by F. WILKINS. Paper. 20 cents.
 THE DOMESTIC USES OF COAL GAS, AS APPLIED TO LIGHTING, by W. SUGG. \$1.40.
 DISTILLATION OF COAL TAR AND AMMONIACAL LIQUOR, by GEO. LUNGE. New Edition. \$12.50.
 ILLUMINATING AND HEATING GAS, by W. BURNS. \$1.50.

A TREATISE ON THE COMPARATIVE COMMERCIAL VALUES OF GAS COALS AND CANNELS, by D. A. GRAHAM. 8vo., Cloth. \$3.
 GAS COMPANIES DIRECTORY. \$3.
 GAS VERSUS ELECTRIC LIGHT. 50 cents.
 THE AMERICAN GAS ENGINEER AND SUPERINTENDENT'S HANDBOOK, by WM. MOONEY. \$3.
 DIGEST OF GAS LAW. \$5.
 GAS ENGINE INDICATOR DIAGRAM, by W. E. AYRTON. Paper. 20 cents.
 TESTING PIPES AND PIPE JOINTS, by M. M. PATERSON. 80 cents.
 DESIGNING WROUGHT AND CAST IRON WORK, by H. ADAMS. Paper. Three parts, 60 cents each.
 NOTES IN MECHANICAL ENGINEERING, by H. ADAMS. \$1.
 STRAINS IN IRONWORK, by H. ADAMS. With plates. \$1.75.
 GAS WORKS—THEIR ARRANGEMENT, CONSTRUCTION, PLANT, AND MACHINERY. \$8.

A. M. CALLENDER & CO., 42 Pine Street, New York.

GAS METERS.

GAS METERS.

GAS METERS.

GEO. J. MCGOURKEY, Prest.

WM. H. McFADDEN, Vice-Prest. (Phila.)

WM. N. MILSTED, Gen. Supt. and Treas. (New York).

WM. H. DOWN, Sec.

THE AMERICAN METER CO.

WET AND DRY GAS METERS.

PRESSURE REGISTERS.

METER PROVERS.

STATION METERS.

PRESSURE & VACUUM REGISTERS.

PORTABLE TEST METERS.

EXHAUSTER GOVERNORS.

PRESSURE & VACUUM GAUGES.

EXPERIMENTAL METERS.

DRY CENTER VALVES.

CRESSON GAS REGULATORS.

AMMONIA TEST METERS.

GOVERNORS FOR GAS WORKS.

MARSLAND WATER METERS.

BAR & JET PHOTOMETERS.

Manufactories:

512 West 22d St., N. Y.
Arch & 22d Sts., Phila.

GAS STOVES.

SUGG'S "STANDARD" ARGAND BURNERS,
SUGG'S ILLUMINATING POWER METER,
Wet Meters, with Lizar's "Invariable Measuring" Drum.

Agencies:

177 Elm Street, Cincinnati.
244 & 246 N. Wells Street, Chicago.
310 North Second Street, St. Louis.
222 Sutter Street, San Francisco.

HELME & McILHENNY,

(Established 1848.)

GAS METER MANUFACTURERS,

Nos. 1339 to 1349 Cherry Street, Philadelphia, Pa.,

WET AND DRY GAS METERS, STATION METERS, EXPERIMENTAL METERS, METER PROVERS,

Center Seals, Pressure Registers, Governors, Indicators, Photometers, and all other kinds of Apparatus for use in Gas Works.

FOULIS' PATENT STATION AND DISTRICT GOVERNORS.

REPAIRING DEPARTMENT.—We employ a special force of skilled workmen repairing meters of all makers.

WM WALLACE GOODWIN, Prest. and Treas.

WM. H. MERRICK, Vice-Prest.

S. L. JONES, Sec.

S. V. MERRICK, Supt.

THE GOODWIN GAS STOVE AND METER CO.,

Successors to W. W. GOODWIN & CO.

1012, 1014 and 1016 Filbert St., Phila., Pa.

142 Chambers St., New York City.

76 Dearborn, St., Chicago, Ills.

WALDO BROTHERS, Agents, 88 Water Streets, Boston, Mass.

MANUFACTURERS OF

DRY AND WET GAS METERS,

Station Meters (square, cylindrical, or in staves), Glazed Meters, King's and Sugg's Experimental Meters, Lamp Post Meters, etc., etc. Meter Provers (sizes 2, 5, and 10 feet), Pressure Gauges of all kinds, Pressure Registers, Pressure and Vacuum Registers, Pressure Indicators (sizes 4, 6, and 9 inch), King's Pressure and Vacuum Gauges, Dry and Wet Center Seals, Dry and Wet Governors, Exhauster Governors, Photometers of all descriptions. Letheby's Sulphur and Ammonia Test Apparatus complete. Also, Testing and Chemical Apparatus of all kinds, and of the most perfect description, for all purposes relating to Gas.

Manufacturers of the "SUN DIAL" GAS STOVES, for Cooking and Heating.

Goodwin's Improved Lowe's Jet Photometer.

Agents for Bray's Patent Gas Burners and Lanterns.

Special attention to Repairs of Meters and all Apparatus connected with the business. All work guaranteed first-class in every particular. Orders filled promptly.

G. B. EDWARDS, Manager, New York.

S. S. STRATTON, Manager, Chicago.

D. McDONALD & CO.,

GAS METER MANUFACTURERS.

(Established 1854.)

51 Lancaster St., Albany, N. Y.

34 & 36 West Monroe St., Chicago, Ill.

STATION METERS, EXPERIMENTAL METERS, METER PROVERS, PRESSURE & VACUUM REGISTERS, PRESSURE GAUGES, ETC

Also STAR GAS STOVES, RANGES, and HEATING STOVES.

We use only the very best materials, and employ the most skilled labor, and by our long experience (32 years) and personal supervision of every detail, we feel justified in assuring the public that our goods will give perfect satisfaction. Every Meter emanating from our establishment will bear the State Inspector's **BAZOK**, and will be fully warranted by us. Our Annual and Calendar will be sent to Gas Companies upon application.

GAS INTO POWER,

BY THE

OTTO GAS ENGINE.

GAS POWER.—A Source of Revenue to Gas Companies ready to engage in Electric Lighting, building of Water Works, Electric Street Railways, etc.

Coal for producing Gas is less in amount than that for producing Steam, both being measured on an equal amount of work performed. And, further, with Gas,

50 to 90 per Cent. of Value of Coal is Returned

by sale of Coke and Tar, according to the market value of these products.

Labor for handling fuel is reduced, by its becoming centralized and confined to the gas house, and frequently has not increased after the addition of a power station.

With Gas Power, cost of fuel is strictly limited to the time of use.

MANY VALUABLE
AND RECENT
IMPROVEMENTS.

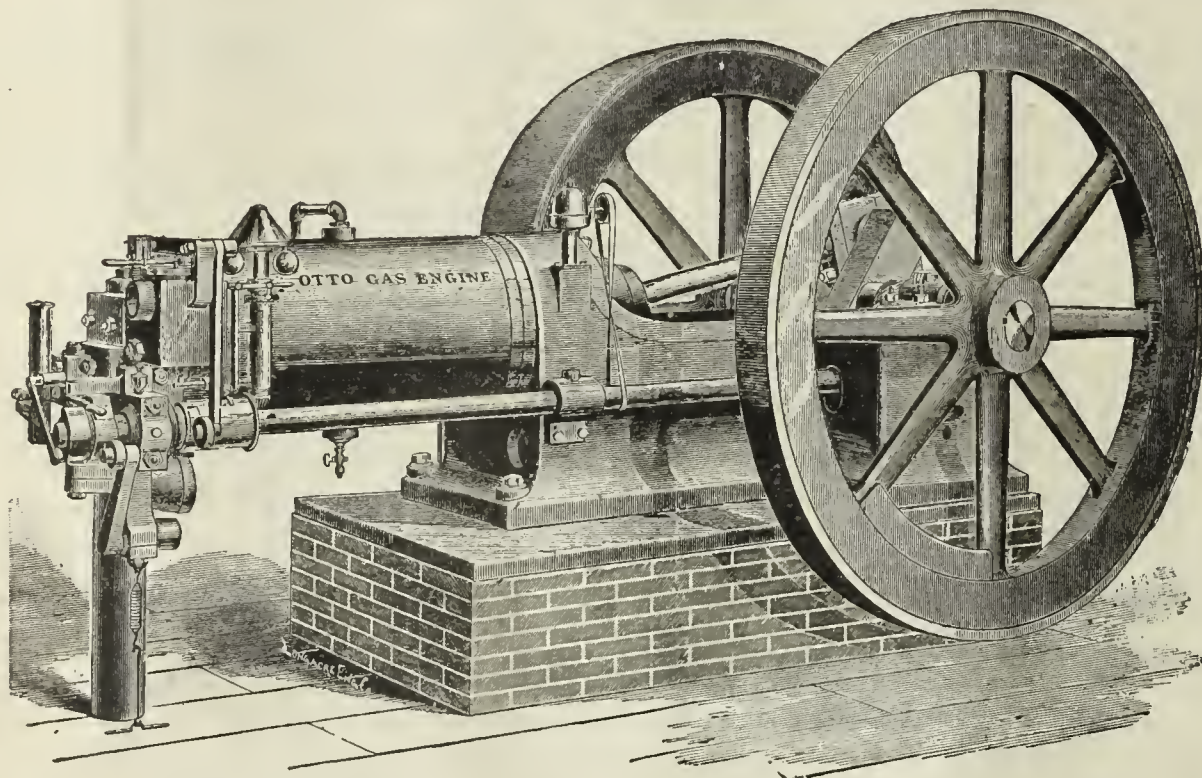

SIZES,
1-3 to 100
HORSE POWER.

Wherever Gas Companies tried Gas Power with Steam Power together in one Station, the use of Steam was subsequently abandoned or restricted, and Gas Power made to take its place.

Where Gas Companies adopt Gas Power for Electric Plants, Water Works, Sewerage, etc., they not only choose the most economical power for their use, but secure to themselves the numerous advantages of increased production, without increase of expense, and benefit thereby their entire manufacture. They induce consumers, by their example, to abandon Steam for Gas Power, and, by establishing special rates, make

Gas Power the Leading Power of To-Day,
AND SOLVE AT ONCE THE QUESTION OF FUEL GAS.

“Otto Gas Engine Works,”

SCHLEICHER, SCHUMM & CO.,

151 Monroe St. (Kent Building), Chicago.

33d and Walnut Sts., Phila.

NEW YORK AGENCY, 18 VESEY STREET.

THE AMERICAN

GAS LIGHT JOURNAL

REDMAN & KENNY, N. Y.

PUBLISHING OFFICE No. 42 PINE STREET

DEVOTED TO THE INTERESTS OF ILLUMINATION, VENTILATION, WATER SUPPLY AND DISTRIBUTION, & GENERAL SCIENCE.

VOLUME LII.—No. 11.
Whole No. 771.

NEW YORK, MONDAY, MARCH 17, 1890.

{ \$3 PER ANNUM,
IN ADVANCE.

A. M. CALLENDER & CO., Proprietors. C. E. SANDERSON, Manager.
JOS. R. THOMAS, C.E., Editor. T. J. CUNNINGHAM, Asst. Editor.

ENTERED AT THE POST OFFICE AT NEW YORK, N. Y.
AS SECOND CLASS MATTER.

Published on each Monday of the year, at No. 42 Pine Street, N. Y.

Terms of Subscription, Including Postage.—For the United States and Canada, \$3 per annum. European countries, \$4.50 (19 shillings—22½ francs). All payments to be made in advance. Single copies, 10 cents.

Remittances should be made either by post-office order, registered letter, or bank draft on New York, payable to the order of A. M. Callender & Co.

Collections are invariably made directly from this office, for subscriptions, advertisements, etc. We have agents to solicit the same, but they are not authorized to receipt for money.

Correspondence.—Wishing to make this JOURNAL a gazette of intelligent discussion to those of our readers who may wish to gain or give information on the subjects to which its columns are devoted, correspondence is solicited for publication from all who make the study of those subjects a pleasure or a profession.

The American News Company, Nos. 39 and 41 Chambers street, New York, are agents for this JOURNAL. Newsdealers will send orders to them.

Books.—We will forward by express, at publisher's lowest rates, any book—scientific or otherwise—to any address in the United States or Canada. No books will be sent C. O. D.

CONTENTS.

An Asterisk (*) denotes an illustrated article.

OFFICIAL NOTICE—

Ohio Gas Light Association..... 353

EDITORIALS—

Briefly Told..... 354

Opposition at St. Joseph, Mo.—What Advertisers Say.

Results from the Van Steenberg Water Gas Apparatus..... 354

Twentieth Annual Meeting, New England Association of Gas Engineers—Official Report, Revised by the Secretary—Continued from page 326..... 355

Second Day, Morning Session: In the Matter of Badges—Some Notes Taken in a Small Gas Works, by Ralph Woodward—Discussion—*Vaporization and Feed of Oil to Generator and Retort, by W. R. Addicks—Discussion—Problems Constantly Before the Gas Manager, by E. H. Yorke.

Notes on Fuel Gas, by G. W. Goetz..... 362

ITEMS OF INTEREST FROM VARIOUS LOCALITIES..... 363

Hints from Salem, Mass.—Improvements at Springfield, Mo.—Annual Meeting, Memphis, Tenn.—A Baltimore Ordinance—Suing the Chicago Gas Trust—A Waif from Salem, O.—Another, from Belleville, Ill.—Annual Meeting, Nashville, Tenn.—Suit for Damages—Public Lighting, Lincoln, Neb.—Fuel Gas for Louisville, Ky.—Cheaper Gas for Oswego, N. Y.—The Record of a Year at the Richmond (Va.) Gas Works—A Legislative Hearing—Public Lighting, Troy, N. Y.—An Opposition Proposition at Salt Lake City—And Many Other Items.

Economy of Fuel in the Distillation of Ammoniacal Liquor..... 365

The Market for Gas Securities..... 365

[OFFICIAL NOTICE.]

Ohio Gas Light Association.

OFFICE OF SECRETARY,
COLUMBUS, O., February 22, 1890.

To Members of the Ohio Gas Light Association:

Gentlemen—As previously announced, the Sixth Annual Meeting of this Association will be held at Toledo, O., beginning at 10 A.M., March 19, 1890, and continuing two days. Boody House will be the headquarters of the meeting, the various sessions of which will be held in a very suitable room in the same hotel. Members and others desiring to attend are advised to write well in advance for rooms.

The following papers have been promised for the meeting:

1. "Theory and Practice in Gas Management," J. M. Bate, Supt. Gas and Coke Company, Canton, O.
2. "Municipal Control of Lighting," H. Wilkiemeyer, Supt. Gas Light and Coke Company, Portsmouth, O.
3. "Combination of Gas and Electric Lighting in a Small Town," George W. Bowers, Sec. Gas and Electric Light Company, Hillsboro, Ohio.
4. "Our New Coal Gas Works," G. A. Hyde, Engineer Gas Light and Coke Company, Cleveland, O.
5. "Advantages of a Combined Coal and Water Gas Plant," Geo. Light, Asst. Supt. Gas Light and Coke Company, Dayton, O.
6. "Another Year with Fuel Gas," Chas. H. Evans, Manager National Gas Company, Jackson, Mich.
7. "Ohio Street Lighting Statistics," W. C. Hedges, Secretary Gas Light Company, Mansfield, O.
8. "Graduated versus Uniform Rates," Chas. R. Faben, Jr., Supt. Gas Light and Coke Company, Toledo, O.

The following questions have been proposed for the "Question Box:"

1. At what point in the works is the best place for the exhauster?
2. In a lighting territory covered by illuminating gas and the incandescent electric light, which seems to be in the ascendency?
3. Does a fine gas of 23 to 25-candle power help check the invasion of the incandescent electric light?
4. Should we not confine the work of our Association to the important interest it was established to promote, viz.: gas lighting and the manufacture of coal gas?
5. What system of electric lighting is best for adoption by gas companies?
6. Are cast iron pipes better and cheaper than wrought pipes for gas mains of 2 to 4 inches in diameter?
7. Does it pay to coat gas mains with coal tar?
8. What is the average life of a meter in constant use, with ordinary good care?
9. Is not illuminating gas of good candle power, sold at a reduced price for fuel, the true solution of the fuel gas problem?
10. Which is the correct method of tapping mains, on top or at the side?
11. Is the Welsbach burner with natural gas a success, and what proportion of the lighting does it do in towns having both natural and artificial gas?

Other interesting questions have been proposed, which will be presented at the meeting, and members are requested to come prepared to participate in the discussion of the above papers and questions.

Provision has been made for an exhibit, in connection with the meeting, of all kinds of gas appliances and apparatus, a large room on the ground floor, a few doors from the hotel, having been secured for this purpose. No charge for floor space will be made to exhibitors, and those desiring to avail themselves of this excellent opportunity of displaying their specialties will consign their goods and address their communications to Mr. Chas. R. Faben, Jr., Supt. Gas Light and Coke Company, Toledo, O., who has the matter in hand, and who will arrange the exhibit to the best advantage of all concerned.

In addition to this exhibit there will be other objects of much interest to our members and visitors, and the meeting promises to be in every way successful. It is hoped that every member will show his appreciation of what has been done, by being present; and gas companies not heretofore represented at our annual gatherings will be profited by sending a representative to this meeting.

A cordial invitation is constantly extended to all who may desire to become members of the Association, to do so, and the Secretary would be pleased to hear from any such persons.

IRVIN BUTTERWORTH, Sec'y.

BRIEFLY TOLD.

OPPOSITION AT ST. JOSEPH, MO.—For some time back our item columns have contained the various chapters of history that were made in connection with the attempts to establish an opposition gas company at St. Joseph, Mo., and we think that taken in its entirety the history is very amusing, in that it furnishes a record of duplicity, cunning, ignorance and rapacity. Some months ago one W. S. Crosby, of Chicago, at the instigation of certain parties who will not be named here, received a hint that St. Joseph, Mo., was a likely situation for an opposition gas company, and it cannot be gainsaid that the hint was a good one, for the old St. Joseph Gas and Manufacturing Company had always been a steady dividend payer. In fact the only circumstance that could cloud the brightness of the schemer's chances was the possibility that the local authorities, remembering the liberality with which the city and citizens had been treated by the old Company, would refuse to assent to a plan that must necessarily depreciate its property. However, Crosby and his backers made application for a charter to the Council, the provisions of which have already appeared in the JOURNAL—in fact their precise nature is not of great moment, since they were founded on the skeleton plan that serves as the basis for all documents of a like nature. In due time, and upon "mature thought," the Council laid the application on the "suspense hook," which was supposed to end the matter. In passing it might be remarked that such a course was adopted chiefly on the ground that the old Company should be protected, because of its good record, and because it was managed by home capitalists. This last argument seems to have shown to certain local parties a way of whipping in on their own account, and in due course of time one McGuire appeared before the Council in the guise of a home rule advocate for an opposition charter. If we mistake not, still another of the same stripe petitioned for like recognition. The newcomers seem to have been able to "convince" the Council that their prayer should be answered. In any event they have carried the day, and whether it is McGuire or Allerton—or whether there is any real difference in their interests or not we cannot say—the franchise has been granted as per the conditions printed on pages 328 and 329 of our last issue. It would seem as if Crosby ought to feel rather sad about this time—unless, indeed, he is a friend of "McGuire's." This does not seem altogether improbable, especially when one remembers that the charter awarded is much more favorable in its provisions than that asked for by Crosby. In fact, under the new charter the proprietors cannot fail to make a good thing out of it, should they ever be able to induce Mr. Turner and his fellows of the old St. Joseph Company that it would be worth their while to buy it. In connection with this we herewith publish the following letter from Mr. J. H. Farrish, Secretary of the St. Joseph Gas and Manufacturing Company, which requires no particular comment, save in respect to his implied doubt as to whether we "find subscribers in the far East interested in the misfortunes of a Western Company." To that we can only reply—and in such reply feel that we are right—there is no sectionalism in the gas business, for what affects one affects all, hence all are interested. Mr. Farrish writes: "To the Editor AMERICAN GAS LIGHT JOURNAL: Inclosed find clippings which tell the tale. The original projector of the Jackson fuel gas scheme for St. Joseph—Mr. W. S. Crosby—got left, a franchise having been granted to a St. Joseph syndicate. Our Common Council, for reasons best known to themselves, have concluded that it is best for the city to have two gas companies hereafter. The new

franchise does not limit the new Company to any kind of gas or known process of manufacture; we do not, therefore, know what to expect. We shall keep you posted from time to time, provided you find subscribers in the far East interested in the misfortunes of a Western Company.

"Very truly yours, J. H. FARRISH."

"Since the above was written the bill has been vetoed by the Mayor, and passed over his veto. It is now a law.—J. H. F."

WHAT ADVERTISERS SAY.—We are not given greatly to the practice of telling how we are regarded by our advertisers and subscribers in the matter of the wares of the former and the needs of the latter, in so far as each may be served in those respects by an appeal to our columns. In this instance, however, we will transgress the rule by the submission of the following letter, which goes to show plainly the value of advertising in a technical paper, which has neither friends to protect nor enemies to punish. In other words, a paper that seeks to serve honestly the people who support it.

"H. W. Rappleye, Constant Volume Gas Burner, }
"Office, 1345 Arch St., Philadelphia, March 12, 1890. }

"Messrs. A. M. Callender & Co., 42 Pine street, N. Y.—Gentlemen: Herewith I hand you my check to your order for \$— (amount of inclosed bill), which please receipt and return. I also inclose additional 'ad.' which you will please insert in next issue. Somehow (unexplainable to me) the JOURNAL reaches a line of trade which I have heretofore been unable to secure. Yours very truly, H. W. RAPPLEYE."

Results from the Van Steenberg Water Gas Apparatus.

The Van Steenberg process of gas manufacture, which in its American type is well and not most favorably known to our engineers, is being illustrated in a practical way in England, at Humphrey's Hall, Knightsbridge, the trial run having been committed to the care of Prof. Vivian B. Lewes. This gentleman has compiled the following figures, which explain themselves:

TABLE I.—Giving Full Details of the Make of Carbureted Water Gas by Van Steenberg's Plant (Feb. 11, 1890).

Quantity of gas made.....	8,400 cubic feet.
Time occupied—	
In blowing.....	58 minutes.
In gas making.....	48 "
Fuel consumed—	
Anthracite.....	205 lbs.
Naphtha (70° Beaume).....	23 galls. 6 pts.
Illuminating power of gas made (corrected)	20.5 candles.

Analysis of Gas.

	Unpurified. Per Cent.	Purified. Per Cent.
Hydrogen.....	—	40.33
Marsh gas.....	—	17.08
Illuminants.....	—	7.59
Carbonic oxide.....	—	25.00
Carbonic acid.....	2.15	0.50
Oxygen.....	—	0.17
Nitrogen.....	—	9.33
Sulphureted hydrogen.....	2.84	nil
		<u>100.00</u>
Total sulphur (by Letheby test).....	6.67 grains per 100 c. ft.	
Sulphureted hydrogen in unpurified gas	23.80	" "
Sulphureted hydrogen in purified gas..	nil	
Ammonia.....	nil	
Bisulphide of carbon.....	nil	

Consumption of Materials per 1,000 Cubic Feet of Gas Made.

Naphtha.....	2 galls. 6½ pts.
Anthracite.....	24½ lbs.

TABLE II.—Showing the Composition and Illuminating Power of the Gas Made by the Van Steenberg Plant from Various Carbonaceous Fuels with 76° Naphtha.

	Foundry Coke.		Gas Coke.		Anthracite.	
	Unpurified.	Purified.	Unpurified.	Purified.	Unpurified.	Purified.
Hydrogen.....	33.44...	—	39.05...	—	38.44	—
Marsh gas ...	23.38...	—	26.71...	—	19.30	—
Illuminants...	11.14...	—	9.27...	—	7.49	—
Carbon monoxide.....	19.00...	—	13.50...	—	23.81	—
Carbon dioxide.....	2.24...	6.01...	1.02...	2.16...	0.42	—
Nitrogen.....	9.50...	—	9.72 ..	—	9.69	—
Oxygen.....	1.30...	—	0.73...	—	0.85	—
Sulphureted hydrogen.....	nil	0.35...	nil	trace...	nil	—
		Candles.		Candles.		Candles.
Illuminating power (corrected)	22.4	—	22.9	—	21.8	—

NOTE.—The low carbonic oxide in the make from gas coke is due to the fuel never being so hot as with anthracite; and the result is an increase in the percentage of carbonic acid in the unpurified gas.

OFFICIAL REPORT.—REVISED BY THE SECRETARY.—CONTINUED FROM PAGE 326.]

TWENTIETH ANNUAL MEETING, NEW ENGLAND ASSOCIATION OF GAS ENGINEERS.

HELD AT YOUNG'S HOTEL, BOSTON, MASS., FEB. 19 and 20, 1890.

SECOND DAY—FEB. 20—MORNING SESSION.

The Association met, pursuant to adjournment.

The President—The representatives of the Boston Gas Company are asking whether the Association will accept the invitation to visit the works to-day, and I have given them to understand that on account of the storm we cannot probably visit them. It may not be necessary to put the matter to a vote, but at the same time if I am wrong I would like to be made right. I told them, knowing the grounds down there to be very bleak, that I did not think it would be prudent for us to visit them, although we are very sorry to give it up. [It was therefore informally agreed on, for the reasons stated by the President, that the Association would not make the visit.]

IN THE MATTER OF BADGES.

Mr. Stiness—For the Committee on Badges I desire to report that the committee had an informal meeting yesterday, and that they recommend a gold badge, similar in appearance to the monogram on the programme of this meeting, the badge to be made either in the form of a button or as a pin with a patent fastener. The cost will be about \$3. It was also the opinion of the committee that the badges should be paid for by the members purchasing them, and not out of the funds of the Association. I did intend to introduce a resolution—if you will pardon me I will state it now—to the effect that the committee be continued, and that the Secretary be requested to obtain the names of those who will take a badge. Personally I make a very decided protest against appropriating the small amount we have in our treasury for the payment of badges.

The President—I think we will defer further business on this subject, and listen to the paper, by Mr. Ralph Woodward, of Waltham, Mass., entitled—

SOME NOTES TAKEN IN A SMALL GAS WORKS.

The subject of the management of small gas works has been so often written on, and in this Association so fully treated, that I feel I can add but little to the volume of experience that has already been handed in; but, owing to the persistency of our Secretary, I stand before you. My paper will be nothing more than its title suggests—some notes jotted down from time to time.

Most of us have some "hobby" we are particularly fond of riding. To many it is purification, others enrichers, and others leakage and condensation. There is hardly any subject more profitable in discussion than this last—leakage and condensation.

In this State alone, last year we had as "gas unaccounted for," 267,865,892 cubic feet, or 0.083 per cent., and the weather has been particularly favorable to a small leakage. We have all worked on this question and much has been done; but our work is only relatively satisfactory. Large leaks generally make themselves known by their very offensiveness, and are easily remedied, but small ones are sometimes very troublesome to locate. Probably our greatest loss from leakage comes from this latter cause.

To how small a percentage is it possible to reduce leakage? It depends on many conditions—age of mains, kind of joints used, depth of main, etc. With a good system of valves and with appliances for frequent testing and systematic work, much can be accomplished. As has been said, small leaks give us our greatest annoyance. I have in mind one street, not over a half mile in length, that, after the winter of 1887-8, when tested with prover, showed a leakage of 25 cubic feet an hour—219,000 cubic feet per year. After careful examination and repair we had been unable to find a leak that would amount to more than one cubic foot an hour, but had found a plenty of small ones, you may be sure.

In the system under my care we have nearly 17 miles of mains, and it is mostly small pipe, which, as you will agree, is more susceptible to leakage than larger pipe; and on this system we have 112 street valves, so arranged that any section between them can be separately tested.

The average distance between our valves is 800 feet, and while in old systems it may not be expedient, yet, in laying out new work, valves should be put in about 500 feet apart, and always at street intersections. We use "long-end" valves with a 3/4-inch pipe running to either side, and a 10-light test meter, with index on top, to read amount passed an

hour by observations of one minute, and keep a careful record from year to year of the leakage of each street.

With such a system, and a thorough knowledge of the probable day consumption of the district under test, leaks can be located with great precision. Our loss last year was 55,435 cubic feet per mile of main; small, compared with many works, but enough to demand an inquiry how it can be still further reduced,

How much do we lose by actual leakage? How much by defective meters? And how much by condensation?—by which we mean shrinkage or loss from difference in temperature. It has been stated that our loss from shrinkage in this region will average 2 1/2 to 3 per cent. If we can count on this loss for a surety, the remainder of our loss by "gas unaccounted for" will, in many cases, be but a small factor. Our gas is measured at the works at an average temperature of, say, 60° F. I question if the average temperature of house cellars is far below this.

Too little stress has been laid on the regular testing of meters, which are tested at intervals, but usually at intervals too far apart. From all meters tested by me last year we have the following results:

Correct or within 2 per cent. limit.....	159
Slow, average 6.6 per cent.....	82
Fast, average 4.9 per cent.....	21
Failed to register.....	4
Total	266

Average, 1.68 per cent. slow.

Our practice is to give every new consumer or tenant a new meter, or one known to be correct; thus my list includes all meters brought in, whether they have been in use six months or six years. We can safely count on an average of 2 per cent. loss, in our Company, from slow meters where they have been in constant use over five years.

Our Company has suffered, to a great extent, from the effect of having a system of drains and sewers laid through our city. Our mains have been broken, long stretches of mains have had to be removed and again relaid, and sewers crossing these new trenches break from unequal settling. I mention this only as an instance of the loss and annoyance we are subjected to, and few of us have any redress.

Some companies run a main for gas under each sidewalk. This surely would solve this difficulty.

Our Company has made a creditable record in its sale of gas stoves, but nothing that can be called satisfactory. We put our stoves on a month's trial, and, if then wanted, sell at bare cost, fitted up. Two difficulties in extending the introduction of stoves, that lie in the stoves themselves, are: They cost too much for the amount of work that can be done; and many of them give a disagreeable odor when burning.

In a series of tests made with Lungren lamps under different pressures, and adjusting the flame to burn at its minimum and keep lighted, we found, with the pressure we carry, that a 12-foot lamp could not be kept burning safely with less than 1 cubic foot an hour. Customers objected to this extra amount in their bills, so we had to set our lamps to shut off entirely during the day. I might say that our lamps were easier to keep in good repair when kept lighted.

The disposition of residuals is always a good theme for discussion. The electric light, for many of us, has helped solve the coke question, and if good sales can be made outside, tar can be used for fuel with good results.

We find 82 gallons of tar equal to 1 chaldron of coke, and with us it is economical to use. The advantages with tar are: First, high flame temperature; second, more perfect combination of combustion; third, ease of regulation; fourth, no clinkering and consequent loss of heat.

The Company with which I am connected supplies a manufacturing city whose mechanics are mostly of the best class. They earn good wages, own their own houses, to a large extent, live very comfortably and enjoy many luxuries; yet, comparatively speaking, few use gas either for lighting or cooking. Their houses are always piped for gas, our mains run by their doors, and they surely can afford, at present prices, to use gas; and should we once get them on our system as customers they would not leave us.

What hinders them? An impression I think prevails generally that it is expensive to introduce gas—that is, for running services and setting meters. Our practice is now to carry our pipes to the street line of an abutter, and he to pay all other expenses beyond; but it was not many years ago when a would-be consumer had to help pay for the pipe in the street.

Last year our average charge to abutters was \$2.88 for service and \$2.40 for setting meter, and we make both inlet and outlet connections to meter and pipe back to the "riser." These are surely not extrava-

gant rates; but could we not afford to still further lessen these petty charges?

Our business is to sell gas, and not a stone should be left unturned to help introduce its proper and economic use. How many thousand old iron burners and narrow-necked globes are in use to-day?

The electric light has only proved a blessing in disguise, but kerosene oil is, and has always been, our strongest competitor.

Discussion.

The President—Do any of you wish to question Mr. Woodward with regard to his paper? It is the general impression of gas men that meters, after 5 years' use, lose 2 per cent. Has any one any figures to state as to the amount of loss?

Mr. Stiness—I suppose there is a liability, after 5 years of continuous use, to lose a little; but I believe the practice in most companies now is not to leave them in for that length of time without a thorough test, and making repairs if needed. Mr. Woodward states that he charges for services and setting meters. That is one item which in my opinion should be stricken from the charges of every gas company. I do not charge for services; and if a street is to be opened we cover it as soon as possible with a gas main. I believed a good many years ago that it was poor policy for a gas company to make a man mortgage his house for the sake of lighting; and we have acted on this idea in doing away with all charges of this kind. I believe it would be to the interest of all gas companies to discourage all charges of this kind. I know it is the policy with many companies in Rhode Island and Massachusetts to seek the consumer, and not to compel the consumer to seek the gas company. In our company we do not allow the meters to run for 5 years without testing them. We make a thorough test, and we know that the meter is right when it is put in again.

Mr. Sherman—Are your joints made of cement, or of lead?

Mr. Woodward—All cement joints.

Mr. Sherman—If made of lead I think you would have a much larger leakage. My experience with lead joints is that they require a great deal of attention.

Mr. Woodward—We have no lead joints, except those which cross the bridges in the city; and those have to be relaid very often.

Mr. Allyn—In Cambridge the practice has been similar to that mentioned by Mr. Woodward. We charge the consumer, as near as we can get at it, the actual cost of the service inside the street line, and the cost of connecting meters. When I went to Cambridge the practice prevailed there (I think it still prevails in Boston) that when a consumer applied to have gas introduced into his house, a meter was sent him, and he obtained the gas fitter to make the necessary connections. We found so many places where improper connections had been made, that we stopped that plan, and the company now connects all its meters. There is no doubt but that the plan of changing meters at stated times is a good one, but in attempting it we have met with a good deal of opposition from consumers, who seem to think as soon as we send to a house to take the meter out, we do so because they believe the company is not getting royalty enough for the use of the meter, and will put in one that will work a little faster. I have no figures with me to show the average variations of meters taken out; but we had two extreme cases this winter. One meter had been in constant use in a house for 25 years, and the other for 30 years. On being tested they were both found to be within 1 per cent. of correct.

Mr. Humphreys—Will Mr. Woodward state what day pressure he carries? He speaks of it being necessary to adjust the Lungren lamps to use a foot in the bye-pass.

Mr. Woodward—Perhaps our pressure is a little different from that of other works, but we have to carry almost as much day pressure as we do night pressure, on account of supplying large factories. From the time they extinguish lights at night, until 6 o'clock in the morning, we run on low pressure; but on account of these variations we found that we could not get along with less than 1 foot per hour, on an average, in the Lungren lamps, when turned down low.

Mr. Sherman—Did I understand you to say that the average temperature at which you register your gas is 60° F.?

Mr. Woodward—That is average temperature at the station meter for the year.

Mr. Sherman—What is it in the summer?

Mr. Woodward—The temperature given is the average of the year.

Mr. Sherman—I do not think you credit your loss account with enough for condensation. I think most of us register our gas at very much above 60°, on the average, and we do not credit the loss account with the loss which comes from condensation. When the account is made up it is all charged to leakage account, when in most cases 2 per

cent. of it, and sometimes more, should be attributed to the difference between the temperature at the station meter and that at the consumer's meter.

Mr. Woodward—Our leakage for the last year was 3½ per cent., so that we have not a very large margin to charge off to the difference in temperature.

Mr. Addicks—How do you test the meters?

Mr. Woodward—We test them all in the shop. We go to a house, put in a new meter, bring the old one to the shop, let it stand over night near the prover, and test it in the morning.

Mr. Addicks—The Boston Gas Light Company has sometimes, after testing a meter in the house of the consumer, brought it to the shop and re-tested it, and a difference between the two tests of 4 or 5 per cent. has been found. In some cases where the consumer claimed that the meter was wrong, and asked for a test, we have tested it in the shop and found it correct.

Mr. Sherman—I would like to ask Mr. Woodward how much gas he sells per ton of coal. His leakage is remarkably low. Does he know what the average is?

Mr. Woodward—I cannot state that; but the average yield last year was about 5.2 feet.

Mr. Sherman—In the reports of the Commissioners is there a record of any lower leakage than yours?

Mr. Woodward—I have not seen any; but I judge there will be some small accounts of leakage, because the State Commissioners reported that the average leakage had dropped from 13 per cent. last year to 8 per cent. this year. There is a very great difference.

Mr. Sherman—What is the proportion of your street light consumption to the other consumption?

Mr. Woodward—I have not figured it in that way. We keep the numbers of hours that we burn the street lights.

Mr. Sherman—How many street lights have you?

Mr. Woodward—We have 186 street lights.

Mr. Cogshall—Does the yield of 5.2 include the enricher?

Mr. Woodward—That includes the enricher. Last year we used gas oil as an enricher. We did not use any during the summer, but when we were using it we never ran over 2½ gallons per ton of coal.

On motion of Mr. Allyn a vote of thanks was tendered to Mr. Woodward.

Mr. W. R. Addicks, of Boston, Mass., here read the following paper, on the—

VAPORIZATION AND FEED OF OIL TO GENERATOR AND RETORT.

If what follows serves to bring out future united investigation and discussion of this subject, it will be all that I desire. I wish to treat it at the present writing from a practical standpoint only.

I consider oil the most important factor in a water gas works, and in a coal gas works nearly as much so. In a water gas apparatus bad handling of this product will produce lampblack or tar—the tar well nuisance and fouling of scrubbers, condensation in large quantities in purifying box bottoms and drips, and even both of these substances in the very burners. The same material badly handled in a coal gas retort will produce similar troubles, though possibly to a much less extent.

In addition to the troubles hinted at above, which make life a burden to the gas superintendent and the telephone—an invention of Bell indeed—with oil at 3 to 6 cents per gallon, it increases most seriously the cost of gas in the holders, works' repairs, and the distribution department. I have endeavored to name the important points; your own experience, especially if you have gone through the experimental stage—but even after that stage—will make each of you think of many other points.

I divide my subject under the following heads, which state the principal features to be thought of in the vaporization and feed of oil to gas generator and retort:

A. Oil should be fed under constant pressure.

B. The quantity being fed should be ascertainable at any time.

C. (1st) Any treatment oil receives must be gradual in its changes. It must never be shocked. (2d) After being once brought to a given temperature, this must never be lowered until the oil has become a fixed gas at normal temperatures and pressures.

D. It should be fed to the apparatus at a pressure only just sufficient to permit the oil to enter in sufficient quantities.

E. The quantity fed to a generator (and the same is true of a given number of retorts) should be a constant proportion to the number of thousands of feet of gas being manufactured at the time.

In considering these heads, I will repeat them as separate texts.

A. *Oil should be fed under constant pressure.* When elevated supply tanks are in use, the best automatic device I know of—and I believe everything should be made automatic when possible—is that devised by Mr. Jos. Flannery, at the 132d street station of the Standard Gas Light Company, in New York city.

Fig. 1 illustrates roughly the principle of this, and a possible construction of it.

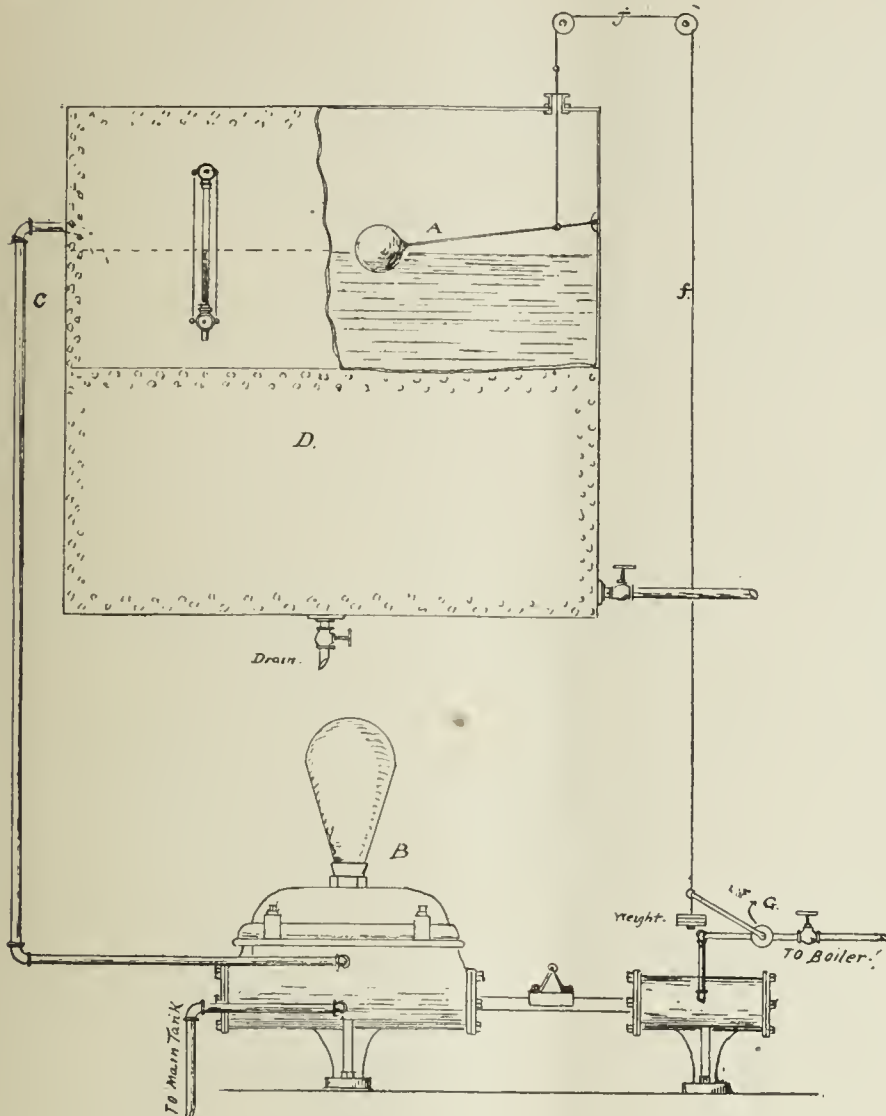

Fig. 1.

The ball and cock *A* rises and falls as the oil is fed, by pump *B*, through inlet *C* and to tank *D*, and drawn off through the outlet *E*. The rising or falling of ball and cock *A* cuts off or admits steam to steam cylinder of pump *B*, by means of cord *f* and valve *G*, preferably of Huntoon regulator pattern. The apparatus is complete of itself.

Where elevated tanks are not desired, either from questions of expense of elevators or from regulations of Fire Commissioners, a system devised by the writer can be used. This is not, as used to day, as absolutely constant as the method above, but it can be made so; and where a new apparatus is made, with duplicate pump and tank, etc., in proportion to quantity of oil desired, it will be so.

In Fig. 2 pump *A* draws oil from main tank *B*, through suction *C*, delivers through supply *D*, upon which is an "Ashton Relief" *E*, discharging back into main tank *B*. Pressure governing tank has compressed air *F*, oil under pressure *G*, and water *H*. Pressure is indicated by gauge *J*, and height of oil, which is variable, by glass gauge *K*, and height of water, which should be constant, by glass gauge *L*. Brass pipe *M*, connecting with regulator *N*, which feeds steam to steam cylinder on pump *A*, regulates the pressure on the pressure tank *G*, the regulator being the principal feature. *O* is the draw-off pipe to free the top of the water from dirt, *P* a drain pipe, and *R* the outlet of tank leading to oil meter, hence to vaporizer, and, last, to the gas machine.

It is intended that the pump and pressure tank shall be placed wherever the storage tanks are located. The pipe leading to the generator house should be of small size, as under pressure it is not required of large size. The whole apparatus is entirely automatic. Excess of pressure takes care of itself; want of pressure would soon be known in the generator house. We have thus obtained the fulfillment of the demands of constant pressure.

B. *The quantity being fed should be ascertainable at any time.* The sight-feeds are probably old friends to all, and there is no necessity of going into any details as to them. Suffice to say they are poor

guessers; or, rather, they permit a gas maker who is a good guesser to make a poor guess as to what he is doing.

I use at the Bay State works an oil meter marked in gallons, having one dial marked one gallon to one revolution of the hand. This, therefore, indicates quarter gallons, and, by estimation, any proportional part desired. This gives an easy reading for the gas maker.

I am sure everyone who has had experience with oil meters will at once say they are not accurate. Well, this is true of the meters in use thus far. I am hoping that the "Hersey," the one I am at present trying, may prove accurate. But even with their inaccuracy they are indispensable, in my opinion. The gas maker can come very closely, indeed, to the exact number of gallons he is feeding per minute. The make of his machine he knows, and so he can run the number of gallons per thousand he is ordered to, or follow out orders for so many gallons at end of each coaling, if he cannot be trusted to use his judgment to the former extent.

So we have now obtained the second condition within reasonable practical accuracy.

C.—(1st.) *Any treatment oil receives must be gradual. It must never be shocked.* Remarks: This will readily be permitted to stand as an axiom, I think; it is evident if oil is thrown cold into a hot apparatus a large quantity of lampblack will at once be formed, followed by a still larger quantity of tar, and some oil in the condition desired for carbureting or enriching.

(2d.) *After being brought to a given temperature this must never be lowered until the oil has become a fixed gas at normal temperatures and pressures.* Remarks: This likewise is an axiom, for would it not be a waste of heat to permit a partially vaporized oil to be cooled in any way?

D.—*It should be fed to the apparatus at a pressure only just sufficient to permit the oil to enter in sufficient quantities.* Remarks: I state this as I have seen oil fed to an apparatus under very high pressure through a (comparatively) minute opening in a spray.

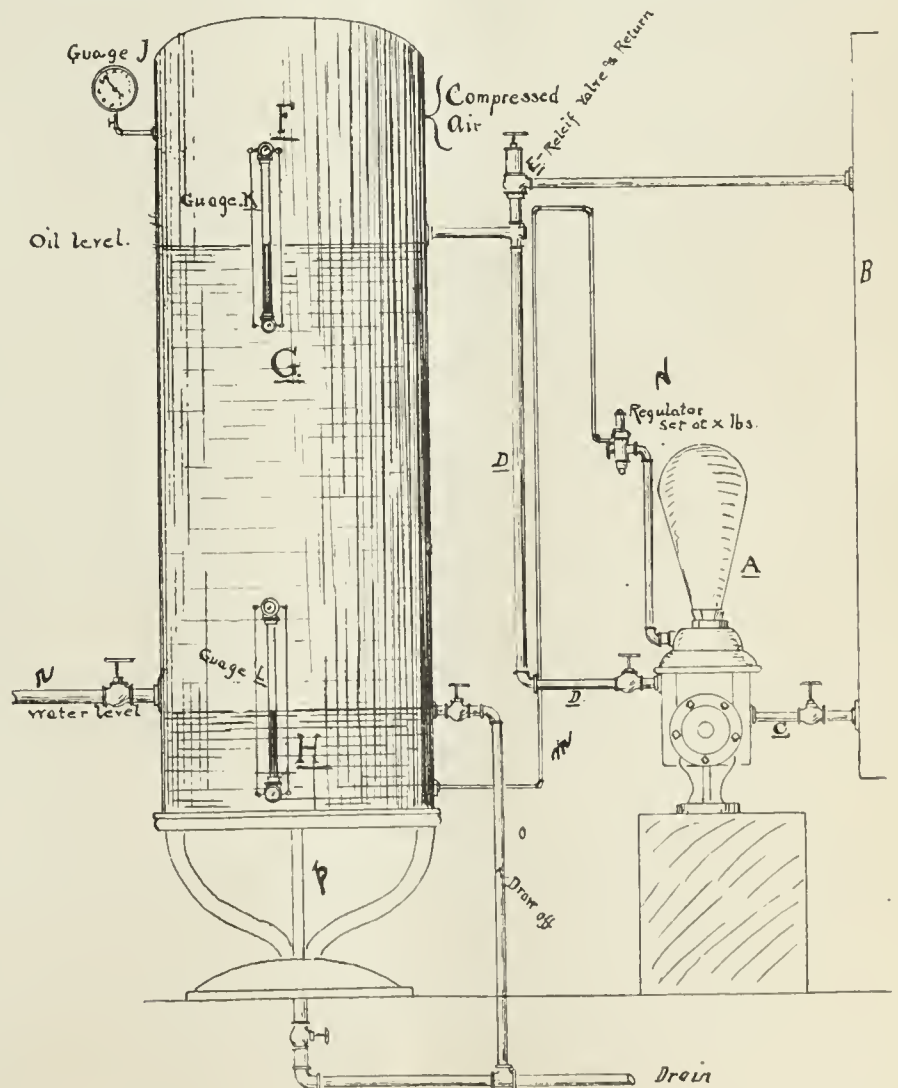

Fig. 2.

You all know that any liquid released under pressure, in expanding to the volume which it must occupy at the pressure and temperature of its released condition, must absorb heat; consequently, in this apparatus the designer called upon the heated chamber to furnish still more heat when the chamber was already overtaxed in this respect. This machine I refer to was popularly known as the "tar machine," which, I think, illustrates my point effectively. It is for this reason I make the condition "D" a vital one. It could be done successfully by

providing considerable preheating; but I consider it bad practice. I have endeavored to obtain the results demanded by the condition, "C," (1st and 2d) and "D" in a partial way only, by means of a vaporizer, though I believe that heat imparted to the oil, such as waste heat, after the products of combustion leave the superheating chamber, is desirable, though not vital, and I believe it is not for this reason.

Granting that oil at 32.5° F. is a vapor, then the quantity of heat necessary to take it 500° higher is comparatively small. I will try to illustrate by arguing from the known to (at least to me) the unknown.

A—Heat units raise 1 lb. water, 32°, to water 212° at pressure 14.7 lbs.	180.52
B—Heat units raise 1 lb. water, 212°, 14.7 lbs. to steam, 14.7 lbs. and 212° F.	966.08*
C—Heat units raise 1 lb. steam, 212°, 14.7 lbs., to steam 300 lbs. and 417° F.	62.56

D—Heat units to raise 1 lb. water, 32° F., 14.7 lbs., to steam, 300 lbs., 417° F. 1,209.16

A is 14.9 per cent. of D.

B is 80.0 per cent. of D.

C is 5.1 per cent. of D.

A + B is 94.9 per cent. of D. (A + B is the condition we are seeking.)

NOTE.—Total heat, steam, 212° F., and 14.7 lbs., is 1146.6, with volume 1644. Total heat, steam, 417° F., and 300 lbs., is 1209.2, with volume, 97.

Granting that oil, being a fluid, follows the same law as water, if we bring oil to a vapor we have attained the result of greatest moment. I have obtained this by means of steam-jacketing the oil pipe from the oil meter to the entrance to the heating chamber. The details of construction are indicated in Fig. 3.

In Fig. 3, A is an oil meter, B is the oil pipe, which increases in diameter in each section when passing through steam jackets C₁, C₂, C₃, C₄, C₅, to inlet to generator D, where it would be, preferably, between 2 and 3 inches diameter. Jackets have inlets for steam in top stuffing

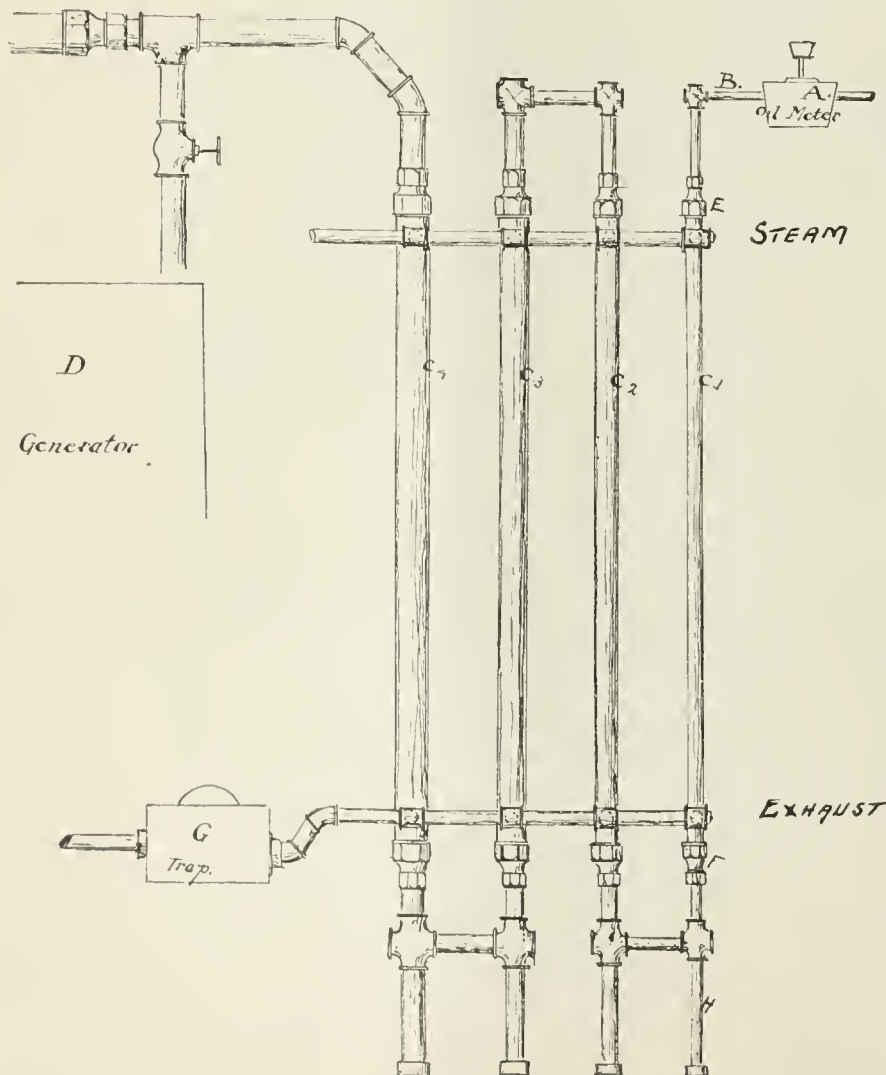

Fig. 3.

box E, and outlets for exhaust in bottom stuffing box F, the exhaust being automatically handled by means of trap G. At the bottom of each section of oil pipe is a drip-pipe H, which collects, by settling, the heavier matters or dirt which cannot be vaporized readily. I question if they are in any way actually needed.

*Made up of units to overcome external resistance, 71.83
Made up of units to overcome internal resistance, 893.81

The oil might be still further carried through heated chambers of temperatures of 600° to 800°.

In the Flannery machine it goes direct into an oil retort, and thence through the superheater, the oil retort being the cooler. The step from 312° to 1,500° of the retort is a great one; but I have pointed out that this is not so sudden as may seem at first sight. Practice bears me out; for at the Bay State works lampblack is unknown, and tar nearly so when naphtha was used. Since crude oil has been used, tar and condensation have appeared in considerable quantities, due to insufficient superheater area. I am at present working to get some exact figures on vaporization of oil, which, with the vaporizer, is an easy matter. Any figures that any members of the Association may have as to the latent heat of vaporization, and the specific heat of naphtha and crude oil, and of oil vapor, would be of service to anyone studying this subject. I believe this subject deserves all the time for investigation that can be spared.

NOTE.—Naphtha will be all vaporized at 300° F., in which case steam of 80 lbs. pressure will give all the preheating desired. With crude oil it is necessary or desirable to heat further, if the circumstances will permit of it with success.

Discussion.

The President—The subject presented in this paper is an interesting one to all of us, and I hope that we may have a full discussion. I think, perhaps, Mr. Shelton has had as much experience as any in the use of oil for gas, and we shall be glad to hear from him.

Mr. Shelton—I have been extremely interested in Mr. Addicks' paper, and I think he deserves a hearty vote of thanks for the thoroughness with which he has gone into a subject which is sometimes overlooked by those engaged in the management of gas works. I think we are not apt to go very deeply into these details of temperature and various qualities of oil. We get the crude oil, pump it in the machine, and if it makes tar, lampblack, or what not we blame it on the gas maker. We do not give enough thought to the why, and wherefore, and reason of it. On the whole I agree with Mr. Addicks thoroughly. I believe in raising the oil gradually to a high temperature, and I think the remarks he has made, although directed mostly in the direction of water gas, apply equally well to the use of oil for enriching in retorts. It is a subject in which coal gas men are interested. I cannot entirely agree with him as to the non-desirability of heating the oil beyond steam heat. I think the utilization of the heat of the producer gas, or of the sensible heat of the hot gas passing off from the superheater, is a matter of very great importance. There is still another point—that in utilizing the heat of the superheater you are killing two birds with one stone. You are not only increasing the heat of the oil, and taking so much work off the superheater and the generator, but you are taking heat away from the hot gas. On the whole, I agree with the exhibition which Mr. Addicks has made, and congratulate him upon the thoroughness with which he has done it.

Mr. Addicks—I will say further that I think if you can get up some practical arrangement to heat the oil by using the waste gases it would certainly be desirable to do so. If you can save one per cent. in that direction I would not hesitate to do it. One point I made with respect to that, was that the amount of heat necessary to do this work is such a small item comparatively, I thought it would not cost more than the interest on the money invested and the cost of repairs thereafter. I think Mr. Shelton told me at one time he did something of that kind; and if he would explain it to us now it would be a gratification to me, at least.

Mr. Shelton—I agree that when we can only save one per cent. we ought to do it. We ought to save anything that we can. It has been the experience of the company that I am connected with that we can obtain a comparatively cheap and effective apparatus to heat the oil—to make the gas by the heat of the gas that is being made. In other words, by utilizing the heat of the gas passing out by interposing some means whereby to heat the incoming oil. It is more a question of the efficiency and durability of the apparatus than of the first cost of it. We have found that a very simple arrangement will fill the bill. It is cheap, it does not have to be cleaned at great expense, and the cleaning is done once a month to once a week, depending upon circumstances. In short, it has fully repaid our putting it in.

Mr. Addicks—Mr. Jones told me that he would be here, and I would rather have him make a statement as to his success in operating this plan. When he took charge of the North End works they had 18 retorts in operation where they now have 12; and the candle power is higher than before with 18. He saves about one-third of the coke, and has a better gas than he had before; he also did away with all the sight feeds that we so often see continually dripping in various works.

Mr. Neal—I am quite interested in this paper, because I am using the Granger-Collins water gas plant, and have tried to use crude oil, but without success. I have a great deal of trouble in the superheaters, from the deposition of lampblack, and they require constant care. I spray the oil in at about 40 pounds pressure in the generator, and it meets the gas just as it is passing from the generator into the superheater. I would like to ask Mr. Addicks if he is acquainted with the Granger process?

Mr. Addicks—Yes.

Mr. Neal—The oil is sprayed in at a very heavy pressure. It is previously heated in a cylinder by steam pipes, which raises it to a very high temperature. It seems to work very well; but I think that perhaps naphtha will work better than crude oil, although it is more expensive.

Mr. Addicks—I think it is a fortunate thing that you do heat it, because if you put it in cold, and sprayed it, it would have a worse effect. I think that the preheating which you give it now serves to counteract the spraying in at high pressure.

Mr. Neal—Do you think I could adopt that method so we could use crude oil in works of that kind?

Mr. Addicks—I think it is a matter for experiment with each style of generator.

Mr. Shelton—I would corroborate that also. I think crude oil is harder to handle than naphtha. Naphtha is a uniform and homogeneous substance, and you can take a single superheater and make gas without trouble. If you make tar or lampblack it is your own fault; there is no necessity for it. But with crude oil you have all sorts of things to contend with; and you have to handle it with a great deal more care. In Mr. Neal's case, where he has the Granger apparatus and a single superheater, it is necessary to watch the heats very closely so as not to crowd the apparatus in using crude oil. In that case I think heating the oil to the highest degree possible holds true of crude oil. That crude oil can be successfully used with the Granger apparatus or with any single form of superheater apparatus I would verify by calling upon Mr. Jenks, as I have the impression that he has used a great deal of oil in the same way that Mr. Neal desires, and with entire success. I think he would prefer to use naphtha if there was no difference in price; but a little difference in price is enough to cause him to favor crude oil.

Mr. Jenks—I was about to ask Mr. Addicks if he thought that the raising of the temperature of the oil before passing it into the apparatus compensated to any degree the lack of superheating surface before reaching the scrubbers.

Mr. Addicks—Unquestionably.

Mr. Jenks—That being the case, I would say "Amen" to an apparatus of that kind, and for this reason. Mr. Neal has facetiously referred to Woonsocket and its gas engine. We have a gas engine in Woonsocket. We also have a double set of water gas apparatus known as the Granger-Collins style, and we are very well pleased with it. There is, however, this feature about it, that in the use of Lima crude oil (and that is what we have always used) we find we have to be extremely careful, not on account of the stoppage in the superheater, however (for I have never seen a speck of lampblack in the superheater), but on account of the lampblack and tar collecting in the wash-box, or seal, as coal gas men would call it, between the superheater and the scrubber. There we have to clean periodically, perhaps, on an average, once a week. Sometimes we find it quite heavy, at others comparatively light, depending on the care that the gas maker has exercised in the operation of his apparatus during the time which has intervened. Mr. Shelton is quite right when he says I would indorse the use of Lima oil, especially when you consider the fact that naphtha costs twice as much. But my opinion is that the setting which the U. G. I. Company are now putting in, known as the double superheater setting, is far in advance of the setting we now have, especially when it is desired to use Lima oil. I think if Mr. Neal had another superheater he would get along without any trouble whatever. While I should like another superheater connected with our works, nevertheless I do not propose to change to naphtha on account of the difference in price. I would rather put up with the extra trouble that the heavy oil occasions.

Mr. Sherman—I would like to ask Mr. Addicks how many gallons of crude oil he uses to a given candle power; say, 22-candle power?

Mr. Addicks—I can only say in reply to that, that we are using naphtha and crude oil, and are getting above 5-candle power per gallon of naphtha. With the vaporizer our candle power went at once up to 6-candle power per gallon of naphtha used. When using crude oil we use it half-and-half, so that it is hard to determine exactly what we do. We are now running about 5-candle power, or a little over, to the gallon. That is our result so far. What the candle power is definitely, after it gets from the works, we have very little opportunity of knowing

thoroughly and satisfactorily. I should say, though, that 5-candle power to the gallon would be a fair estimate for half-and-half.

Mr. Jones—I would like to call the attention of coal gas engineers to the advantages of vaporizing oil before putting it into the retort where it is used as an enricher. I regret very much that I was unable to be here to listen to Mr. Addicks' interesting paper; for I well know that he would not read any other kind of paper. Some time ago I began vaporizing, at the North End gas works, the naphtha before putting it in the retort; and the result has been that I am enabled to use the same amount of naphtha for enriching our gas with 12 retorts that I was before obliged to put into eighteen retorts, and with the further advantage that when I slack off the lid of an oil retort the retort is hot. Before, when I slacked off the pipes through which the oil was passed in, portions of the retorts were black, thus showing that by putting liquid naphtha into the retort we were overworking the retort. There certainly is an advantage in vaporizing oil before it is put into the retort, in the saving of fuel alone. At the North End works I am saving fuel in that way. I am getting better results from the naphtha used, and the naphtha is being converted into commercial gas; and I am positive that less of it is condensed out in passing through the apparatus. I think this matter is well worthy the consideration of all gas engineers who are using naphtha for enriching.

Mr. Prichard—Will Mr. Jones describe his vaporizer?

Mr. Jones—It is the vaporizer that has been already described by Mr. Addicks—a coil of naphtha pipes with a steam jacket.

Mr. Allyn—How do you introduce it into the retort?

Mr. Jones—Through an inch pipe, directly from the vaporizer. There is a main pipe leading from the vaporizer, and from that I take a pipe to each retort. The vapor is carried through a series of pipes inside of the retort. It is the well-known method of breaking up naphtha. There is one wrought iron pipe within another. The vapor traverses nearly the length of the retorts four times before passing up the stand-pipe.

Mr. Neal—How do you obtain your pressure—by gravitation or mechanically?

Mr. Jones—The pressure of the liquid when expanded to a vapor will carry it into the retort.

Mr. Lane—Have you done anything with crude oil?

Mr. Jones—I have not.

Mr. Sherman—How many gallons of naphtha will one retort take care of per hour?

Mr. Jones—We use 2,000 gallons in 12 retorts, and under the old method it would have taken 18 retorts to work it off properly.

Mr. Sherman—How much is that per hour for each retort? As we have used it we have thought that it would take care of about 7 gallons per hour without vaporizing.

Mr. Addicks—That brings up a question that I wanted to ask—and that is how many gallons went into the retort per hour? He is only using a 1-inch pipe—I have recommended 2½ to 3 inches—but we put in four gallons per minute.

Mr. Lane—With us we use five gallons on an average, and introduce it in much the same way.

Mr. Neal—Does Mr. Jones introduce the naphtha by spraying it over the coal?

Mr. Jones—No; the vapor is introduced into oil retorts.

Mr. Learned—What is the relative value of crude naphtha at 68, as compared with crude oil at 40 B?

Mr. Jones—As I have had no experience with crude oil at the North End station, owing to the locality, I cannot reply to that question.

On motion of Mr. Allyn, a vote of thanks was tendered to Mr. Addicks.

The next paper read was that by Mr. E. H. Yorke, of Brockton, Mass., entitled

PROBLEMS CONSTANTLY BEFORE THE GAS MANAGER.

Mr. President and Gentlemen:—By invitation of our Secretary, and feeling it to be the duty of every member of the Association to contribute to the success of the meetings, the writer reluctantly—because of their being abler hands in the Association to intrust the preparation of papers—consented to prepare a paper. Although able papers have been presented, touching, it would seem, on almost every theme, and the ground has been pretty thoroughly tilled, still even if old topics are again presented in a new garb, and the soil again turned over, it ought to yield a rich return. Your attention, therefore, is invited to some problems which are of necessity uppermost in the minds of every gas manager.

The life of a gas manager is one essentially of study. The complex and diversified character of his business calls for a broad and compre-

hensive knowledge of mechanical, scientific and commercial principles and methods.

Starting in his undertaking of managing the affairs of his company, he finds a capitalization, plant and income established by those before him, and which, even if of unequal proportions, he must deal with, so as to secure a reasonable return on the capital invested. Although limited in his opportunities for securing patronage by the confines of the town or city and its neighborhood in which his plant is established, he must so manage as to secure a sufficient sale of his product to meet his operating expenses, keep his plant in repair and order, and have a margin left for dividends. To these imperative requirements he will naturally supplement efforts to improve and increase the efficiency of his plant, to reduce the cost of his product to the lowest possible point, and to increase the revenue of his company. The successful accomplishment of these ends involves careful study and reflection, close application and untiring industry; for in no other way can the solution of the many problems that will constantly present themselves to him be accomplished. Of the larger and more important of these problems, that of cost of production will claim his constant attention. The competition of other forms of lighting makes it imperatively necessary that the cost of production shall be at the lowest possible point, if the general use of gas is to be maintained. While the wide difference in the conditions in the different works admits of no general standard of cost of production being established, there are, however, certain details in the operations, the cost of which should be as low in one works as in another; and if the gas manager finds that another manager, in one of these details, has attained a lower cost, there is obviously an opportunity for him to lower his cost by the employment of the same means and methods.

In entering upon a contemplation of the problem before him he will naturally commence with the cost of materials; and in this detail of the cost of product can accomplish much by calculation and effort. In coal, the yield of gas, quality of gas, and amount of sulphur will be the leading factors, in determining which coal is the cheapest in the end. To illustrate: Assuming that coal A and coal B cost the same in the market, and coal A yields 400 feet of gas per ton more than coal B, and this gas is worth 15 cents, but the cost of purification is one cent per thousand, and enriching two cents more with coal A than coal B, it is obvious that coal B is the cheapest coal in the end. And thus with materials for enriching and materials for removing the impurities from the gas and details of expense of carriage and handling can the minimum of cost be attained by study and effort. Assuming that he has purchased his materials at the lowest possible cost, the next step will be to consider the economical treatment and realization of the maximum of values in them.

As coal is the basis of his product its manipulation comes first for consideration. Having secured a coal whose qualities average the highest, the first item of expense will be the moving of this coal and depositing in retorts or generators. In doing this there should be the least expenditure of manual labor and the economy secured, by a utilization of the laws of gravity, should be substituted, not with complicated and expensive machinery, whose maintenance is costly, but with simple and durable arrangements. Having placed his coal in his carbonizing chambers, at the minimum of cost, the next thing in order will be the realization of the greatest production of gas from the coal. Practice and experience have demonstrated that five cubic feet of gas is about all the gas the coal contains per pound, to be yielded by destructive distillation, and having secured this result the gas manager may reasonably dismiss this item in the cost as admitting of no further reduction.

His next inquiry must be with reference to the kind of apparatus required to produce the necessary results. If he contemplates the introduction of apparatus of new forms in substitution for the old, he will need to consider the outlay required, the advantages and economies to be secured, and should have unquestionable evidence that he is adopting apparatus that has proved good; inasmuch as expensive experiments are alike unprofitable to himself and his company. He will need to carefully analyze every detail, and the requirements in all its parts, and be fully assured before adopting the new apparatus that every requirement is fully met, and that it does not possess even a single fault which would make its use impracticable when put into practical operation. He should especially guard against allowing the advantages represented to obscure to his vision the defects, if any exist. It will be well for him to profit by the researches and experience of other managers, and the more information he acquires relative to their investigations the better he will be able to arrive at correct conclusions. But it will not be wise for him to be guided by the experience of a *single* manager; for he will find, while seeking information, this most anomalous

state of things—namely, that while one manager has introduced a plan or apparatus and pronounces it a success, and is enabled with it to accomplish profitable results, that another engineer, held to be equally able, having tried the same plan, condemns it.

Returning to the point in his inquiries as to the best and most economical kind of apparatus for him to employ, he must determine which of the two processes—namely, coal gas or water gas—will best accomplish the desired end. The two primary factors in this question will be the cost and quality of the gas by the two systems. His investigations in this connection will develop these facts, namely: That with the water gas system he can distribute a gas of greater brilliancy without it smoking, when used in ordinary burners, than he can with the coal gas system. This will commend water gas in this particular, for his experience, doubtless, has convinced him, in these days of lavish illumination, that the more brilliant his gas the more successful it will be in its competition with other forms of lighting, and the more generally it will be used.

In steadiness of flame, he will find that the water gas flame is much more steady than the coal gas, and this will commend water gas; but as a slight off-set to this superiority of water gas he will find that its flame area is less than that of coal gas.

Thus far the weight of evidence has been in favor of his adopting water gas; and he must now examine it in other particulars to see if it possesses any defects which would overbalance its advantages. He will find that water gas contains at least 28 per cent. of CO, which increases its specific gravity to at least 40 per cent. above that of coal gas. He will find that the effect of this increased specific gravity is somewhat of a disadvantage in a two-fold way—to wit, the capacity of his mains for distributing a given quantity of gas will be 21 per cent. less than with coal gas, and the registration of gas by his meters will be diminished in like proportion; but this disadvantage will be partly off-set by diminished leakage. Of the character of the CO, while known that its effects are somewhat more detrimental to health than pure carbureted hydrogen, when breathed in excessive quantities for an extended period, but as numerous cases of asphyxiation have shown but little practical difference in the effect, the presence of CO in the gas need not be regarded as a serious objection.

The cost of the two gases will come next for consideration. He will find, on a make of 100,000 cubic feet per day, that the cost of the respective gases, at outlet of hydraulic main and superheater (the expense beyond will be the same with both gases), will be as follows, to wit:

Water Gas.

Materials—41 lbs. of fuel in generator, at \$4.92 per	
2,240 lbs.	09 cents.
10 lbs. of fuel for steam.....	02½ "
4 galls. of oil, at 5 cents	20 "
Labor.....	03 "
Wear and tear.....	01 "
Total.....	35½ cents.

Coal Gas.

Coal, less residuals.....	20 cents.
Enricher.....	05 "
Labor	08 "
Wear and tear	02½ "
Total.....	35½ cents.

He will, therefore, find, in the matter of cost, that one gas can be made, practically, at as low a cost as the other. His decision, therefore, must rest on other considerations.

He has already determined, in point of brilliancy and steadiness of flame, that it will be best for him to manufacture water gas, but in point of specific gravity, that coal gas would be best. This places him in a position where the conclusion is obvious that the best ends will be served by employing both processes, and manufacturing a gas of part water gas and part coal gas. His conclusion to employ a water gas plant will be strengthened by other advantages of value, which its possession will secure to him, namely, he will not require as much storage room for coal and coke, with the attended cost of construction and expense of repairs. He can manufacture the requisite volume of gas, with smaller purifiers and less holder room; he can better meet the fluctuations in consumption, and thereby increase the surety of his supply, than he can if he employs the coal gas system alone; and, finally, the possession of a water gas plant will diminish his dependence on labor; and organized attempts of labor, to force him to a compliance with its views, will be of but little avail. Having determined this detail in the problem before him, he will next consider the kind of benches he shall employ to car-

bonize his coal at the minimum of cost. The primary considerations in this question will be the cost of the bench, per 1,000 feet of gas, that it produces during its lifetime, its operating without trouble, its effective use of fuel, and its production of gas, per wages for labor. Taking up this question in its details, he must, first, determine whether he shall employ the horizontal or inclined plan of setting retorts. The economy of labor in the inclined system will commend it; but if he concludes to adopt the horizontal system, he must, first, determine the size of retorts he shall employ. The disadvantages of retorts of greater dimensions than 16 x 28 inches, 9 feet long, and the poor economy in using those of smaller dimensions, will commend this size to him. In number per bench, he will find that 7 will be more economical than a less number, while a greater number would bring disadvantages in furnace requirement and height of retorts.

At this point in his inquiries he must determine the kind of furnace that it will be best and most economical for him to employ. Whether simple furnaces and direct heating, or the employment of the regenerative principles, or the conversion of his coke into gaseous fuel in separate chambers, and burning these gases under his retorts, or the utilization of his tar for fuel purposes, will best answer the ends, can only be determined by a very thorough consideration of the principles involved and the action and effect shown by the different plans when used in practical operation. While he will not expect to be able to carbonize his coal with as low a number of heat units as is theoretically sufficient, he will hardly be satisfied to use a simple furnace and direct heating when its use requires at least 50 per cent. of his make of coke to carbonize his coal. He will, therefore, turn to the regenerative principles as a means for securing the greatest economy of fuel. The elements in this question (if he concludes to use a furnace of moderately simple construction) are: First, width and length of furnace, which should have a superficial area of at least 960 square inches; second, a depth sufficient to maintain a fire at least 30 inches deep; third, primary air flues of as large dimensions as the circumstances will allow, in order that excessive draught shall not be necessary; fourth, secondary flues of such form that the air currents will have to pass through a continuous flue of at least 28 feet in length; fifth, a continuous circuit for combustible gases, of at least 30 feet in length, with exits for secondary air at successive points; sixth, stack draught sufficient to maintain a vacuum of at least four-tenths of an inch. Supplementary to those essential elements will be the need that the combustion of the coke shall be moderately slow, the speed of the combustible gases not over 35 per second, and the temperature of the waste gases not over 500° F. If he secures a bench of this description, and is successful in the management of it, he will carbonize his coal with 25 per cent. of his make of coke, and will be able to work off 300 pound, 4-hour charges, will secure 63,000 cubic feet per bench, and may reasonably dismiss this detail, in the cost, as having accomplished the minimum of cost.

The next element in the cost of product for his consideration will be the cost of purification of his gas; and under this head may be included condensing and washing. How best to accomplish a thorough separation of the ammonia and tar from the gas without extracting a portion of the heavy hydrocarbons admits of much consideration. In the removal of the sulphur and its compounds and CO₂ the item of expense will be for materials for purification and labor in handling them. He will find that the cheapest effective purifying agent for extracting the sulphur is a mixture of coarse sawdust and oxidized iron borings. The removal of the CO₂ can be accomplished with lime, and if he have purifiers of a superficial area of 30 square feet per 15,000 feet of gas made, he can purify 50,000 feet of gas per bushel of lime. If he can find a means of revivifying his oxide in his purifiers he will have accomplished the minimum of cost in purification. But should he be unable to revivify his materials *in situ*, that plan which requires the least labor will obviously be the least expensive.

Beyond this point no large opportunities exist for effecting a material reduction in the cost of production; but it will be well for the gas manager to remember that in the minor details of expense ways and means can be found for reducing the cost of them.

While but a general outline of this problem and its solution has been attempted, its treatment has been sufficient to suggest the conditions, means and ends in the question of cost of production.

The next problem constantly before the gas manager, and which stands second in importance to cost of production, is the problem of how to increase the revenue of his company. In considering the opportunities and means for accomplishing the solution of this problem, it will be well for him to start with a consideration of the conditions of supply and management essential to its solution. Quality of gas; this should be as high as it will be judicious for him to distribute; for a high illu-

minating power will favorably influence the increased use of gas. Uniformity in quality is important, and variations in quality should be carefully avoided. The pressure on all the mains should be ample for all requirements; as insufficient pressure, due to mains inadequate in capacity to pass the requisite volume of gas, will obviously cause dissatisfaction among the consumers and effect a reduced sale of gas. Obstructed services, stiff meters, and riser-pipe elbows filled with rust should be sought for and remedied. Attention to consumers' burners, in seeing that they are of proper size and construction, and are properly adjusted, will do much towards increasing the general and satisfactory use of gas, while the judicious and free distribution of burners will materially assist this and return large profits for the outlay.

Cheerful and prompt attention to complaints, courteous treatment of consumers and an accommodating spirit are essential. The sentiment of the community in its relations to the gas company is an important factor. The management should be such that the company will be regarded as fair in its dealings, liberal in its spirit, and progressive in its aims and purposes. But dissatisfaction with the size of the bills will arise among the consumers, even if all the foregoing principles and methods are practiced. With these dissatisfied patrons much pains must be taken, and the reason why their bills are of such amounts made clear to them. It will be well to explain the principle and operation of the meter and its dial, and show them how errors in reading the indices will correct themselves. If this is not sufficient to satisfy them, the meter should be removed and tested on the meter prover in their presence. The imparting of this information will do much towards eradicating that element of distrust, the mystery surrounding the gas meter and gas bills, and which materially retards the more liberal use of gas.

Having determined on the principles and methods which he purposes to employ to establish conditions favorable to the retention of present consumers and addition of new, he will next turn to a consideration of the opportunities that exist, and means which he can employ to secure new users. In his examination of the opportunities for securing new patrons, he will find in that great body of non-users, which exist in every district supplied with gas, a prolific field for effort. In viewing this non-use of gas by many residents of his community, and in seeking for the reasons therefor, he will find them to be: First, the subject of gas not occurring to their minds; second, deficient appreciation of the value and advantages of gas; third, an opinion that it is too expensive. Of the various uses to which these non-users may apply gas, that of lighting, ventilation, heating of rooms, of irons for tailors and hatters' use, of coppers for tinware, of water for the bath, in cooking in families, restaurants, hotels and bakeries, and in gas engines for power purposes, will suggest themselves. These conditions in the non-use of gas call for his pursuance of the following, namely: First, he must bring to the minds of these non-users, the subject of gas; second, he must present its advantages in point of quality and volume of light, cleanliness, convenience and safety; third, he must present a simple statement of cost per burner per hour, and an approximate cost when used under stated conditions.

Of the means and methods which he may employ, it will be well to start with an exhibit at the company's office of the different kinds and sizes of burners, gas stoves, and a gas engine in operation, together with a generous supply of printed matter. Circulars through the mails and the columns of the press will serve as means to draw attention to gas and disseminate information relative to its advantages. Self-lighting burners furnish a minor means for promoting the use of gas, inasmuch as they enhance its convenience. The economy and advantages of the regenerator lamp will contribute to securing new uses, and its introduction, even at a low rental, will bring large returns in profit on sales of gas. The quality of light, steadiness and complete combustion of the gases, make the incandescent gas burner a useful agent in promoting the use of gas, and, finally, in appliances, the gas stove and gas engine offer a means to the gas manager of the largest character for increasing the revenue of his company.

In *methods*, that of personal solicitation will be the most effective; and in view of the field for effort and all the conditions, the employment of a thoroughly informed man, of good address, to solicit new takers ought to be attended with highly profitable results. This solicitor would find large opportunities for employing his talents and energies in increasing the use of gas for the various purposes to which it is applied, and doubtless would be able each year to secure a large number of new takers. He also could comprehend in his duties the inspection of consumers' lighting, and could do many things which would effect the retention of present consumers, the increased use of gas by them, and their better satisfaction with gas and the expense of its use.

One more important means suggests itself to the gas manager for in-

creasing the revenue of his company, and that is in extension of mains. This will be constant with the growth of the town or city, and as it involves a permanent increase in the capital invested in plant, and creates a constant expense in interest, leakage, care, repairs, depreciation, and liability for damages, it calls for very careful consideration. A presentation of all the details of this question would reach beyond the limits of this paper, and the author has, therefore, undertaken but a cursory consideration of the main factors in it and the means which may be employed in accomplishing an increase in the revenue of the company.

The next important problem constantly and permanently before the gas manager is the problem of electric lighting, its present and prospective effect on the gas business, and how best to deal with it. Now, that several years have elapsed since the general introduction of the electric light, both arc and incandescent, the use of it from its novelty and sentimental considerations, is rapidly fading away, and it is being weighed and measured by the hard and practical measurements of commercial estimate of value.

That people like and turn to new things is a self-evident proposition. The control of such a mysterious and subtle agent as electricity had a charm and fascination for most people. Everything electrical has been at the "top round" of popularity for several years; but, unless the signs are wrong, people are beginning to put the electric light in the balance and weigh it for its worth. The moving of a lever and the instant illumination of space remote has lost its charm. The practical turn of mind of people has commenced to assert itself, and the future of electric lighting is to-day somewhat problematical.

Such, then, is the status of the subject which is the basis of the problem now before the gas manager. In entering into a consideration of the details of this question, he will commence with the cost of generating and distributing electricity, and to avoid the confusion of the two lights, the arc and incandescent, will first consider the latter.

Information sufficient for his purpose will be acquired from the results as shown by established electric plants, and which show that the operating expenses have about equalled the revenue, although the charges for light have been about 50 per cent. above the cost of gas lighting—the number of candles being the same in both cases. Reasons for this will be found in the excessive wear and tear of the electric system. For these reasons the conclusions will be forced upon him that as a means for the profitable employment of capital, the business of furnishing electric light offers no inducement. In examining that aspect of the question which relates to the future of the incandescent electric light, he finds that these objections to its use present themselves, namely, that it is not a reliable light, due to the very nice conditions necessary for its perfect operation; that the lamp has a most uncertain lifetime, and subjects its user to much annoyance and trouble by its frequent breaking; that it steadily diminishes in candle power, in exact ratio to the time it is used. Its claims for superiority over gas are, that it is more convenient, gives off no heat, and doesn't vitiate the atmosphere of rooms. Examining these objections in detail, he finds that users are not much influenced against it because of its unreliability, or the frequent breaking of the lamp bulbs, or its inherent quality of diminishing in candle power.

The matter of its increased cost above gas lighting, if the considerations of its claimed advantages have weight, will not effect its general use any more than the increased cost of gas over other lighting agents did when gas came into use, although the difference is less in comparison between electricity and gas. The conclusion, therefore, appears obvious in view of the extent that the incandescent light is established and used, and the length of time that it has been in use, that the probabilities point to its continued use. The gas manager, therefore, is confronted with these facts and this additional one, namely, he sees the steadily and increasing investment in electric lighting, which he realizes may be a menace to his business, hence it would be well for him to enter the field and retard this accumulation of outside inimical capital. If he now establishes an electric plant, and the events of the future should demonstrate that the electric incandescent is to do the lighting, he is in a position to maintain his business and find employment for the vested capital of his company.

Of the arc light there is but little to be said. Its value for out-of-door illumination cannot be questioned. It occupies a field distinctly its own, and meets requirements in street lighting which cannot be met with gas. It is strongly entrenched in its position, and modern civilization will not consent to its displacement by any of the other forms of illuminants. Its position, therefore, is a prominent one, and must be recognized as such by the gas manager, and the earlier (if he has not already done so) he establishes an electric light plant, and secures a portion of the lighting (commercial and municipal) the better he will consult the ultimate interest of his company. He may not succeed in making any money

for his company by distributing electricity, although from the advantages of his position, he will probably be able to earn enough to meet his operating expenses, with a margin for depreciation, but he will do that which it is eminently his duty to do, namely, to preserve and protect his company's interest.

In conclusion, while doubtless but little instruction will be found in my treatment of these problems, and issue will be taken with some of the conclusions, still if it directs attention to the subjects, and suggests new consideration of them, it will serve the useful purpose for which we are all assembled here to-day, namely, the consideration of the problems constantly before us. I thank you for your kind attention.

On motion of Mr. Stiness, a vote of thanks was tendered to Mr. Yorke.

(To be continued.)

Notes on Fuel Gas.

[Read by Mr. G. W. GOETZ, at the Washington Meeting of the American Institute of Mining Engineers.]

As is well known, the general use of natural gas in Pittsburgh and vicinity for domestic and industrial purposes has shown the great advantages and benefits to be derived by the use of a gaseous fuel. In order to ascertain and bring together all the facts relating to a large and economical production, purification, distribution and consumption of fuel gas made out of coal, the Fuel Gas and Electric Engineering Company, Limited, was organized under the presidency of George Westinghouse, Jr.

Interviews with leading authorities, in this country and in Europe, and a careful perusal of the enormous literature on this subject, brought out so many conflicting statements as to show the necessity of experiments, on a large and practical scale, to get accurate data to base ideas upon, and to ascertain the practical difficulties and merits of the respective processes proposed. A large number of experiments were made as to the possibilities of water gas, illuminating gas, producer gas and oil as fuels. A bench of retorts, producers, water gas apparatus, condensers, scrubbers, meters, a laboratory, and a holder, with a capacity of 50,000 cubic feet, being at disposal, it was possible to test the properties of the different gases obtained and to make mixtures of them in any desired proportion. All these experiments were controlled by carefully made gas analyses.

Interesting experiments on the diffusion of gases in a large holder when two gases of different specific gravity enter the holder alternately or at the same time were also made, as well as a large number of tests on the combustion of different gases. Mr. Frederick Siemens' statements on luminous flames and on heating by radiation were fully corroborated by carefully made tests; and gas burning devices, based on the radiation of heat from luminous flames, were developed which will give an efficiency of 84 per cent. of the original heat units in the gas, 54 per cent. of which results in radiant heat and is reflected on the floors of a room. Producer gas is undoubtedly the cheapest fuel gas that can be made, and answers all purposes where the air necessary for its combustion can be heated by the off-going heat of the furnace. Tests have shown, however, that producer gas carries too much nitrogen to permit its distribution to a community, since, in consequence of the presence of this constituent, its calorific power is too low, and its flame extinguishes so easily as to be dangerous for household use. It was important to know how many cubic feet of producer gas 1 ton of coal will give. Conflicting statements as to this point will be found in the literature of the subject, the figures ranging from 150,000 to 250,000 cubic feet per ton. To get at the actual figures by a practical test a ten days' run, night and day, was made. Pittsburgh coal of the following average composition was used:

	Per Cent.
Water	1.26
Volatile matter.....	36.22
Fixed carbon	57.98
Sulphur	0.70
Ash	3.78

In order to get a gas very low in carbonic acid, a much larger depth of fuel than is generally carried in producers was required; and, as it is impossible to poke by hand such a deep fire, a pneumatic rammer was placed upon the producer. This rammer consists of a cast iron ring so constructed that it will not only exert a pressure upon the coal, but also force the coal to the periphery of the producer—which is desired, because the gas has a tendency to creep up along the walls. The ring is raised by air pressure and allowed to fall upon the fuel, the stroke given depending upon the blow desired to make the fuel sink regularly.

A producer of the above type can burn from 12 to 15 tons of coal in 24 hours. A positive air blast is used, and steam is admitted under the grate, the admission of both being controlled by valves at the top of the producer. The result of a 10 days' run, carefully metered, showed that 1 ton of Pittsburgh coal will give, on an average, 131,280 cubic feet of purified producer gas, corrected for barometer and temperature. The gas from the producer passed through scrubbers, condensers and meters, and thence into a holder of 50,000 cubic feet capacity. The carbonic acid in the gas was at times as low as 1.4 per cent., but the average percentage was about 3.4 per cent., at a pressure of 4 inches of water. With a pressure as low as is generally carried on producers in connection with steel melting furnaces, the carbonic acid could have been easily kept at 1 per cent. with such a deep body of fire in the producer. The average composition of the gas was:

CO ₂	3.4
CH ₄	3.1
H.....	9.2
C ₂ H ₄	0.8
CO.....	25.3

The remainder was mainly nitrogen. This experimental determination of the amount of producer gas obtainable from 1 ton of Pittsburgh coal, will enable engineers to judge what they are likely to get from other coals. An interesting fact as to the heat units required to puddle 1 gross ton of pig iron was determined by the engineers of the above company. The experimental gas furnace employed, with regenerators for air only, was designed and superintended by W. F. Zimmermann.

The ordinary single handed puddling furnaces used in Pittsburgh consume about 36,000,000 British heat units per gross ton of pig iron, whereas when gas is employed about 14,000,000 heat units will do the same work. It was found that 13,250 cubic feet of natural gas, with 1,100,000 heat units per 1,000 cubic feet, will puddle 1 gross ton of pig iron, whereas by using a gas with nearly 300,000 heat units per 1,000 cubic feet, 47,000 cubic feet were consumed, and by using a gas with 266,000 heat units 54,000 cubic feet were used to puddle 1 gross ton of pig iron. The number of cubic feet of gas consumed, multiplied by the respective heat units in 1,000 cubic feet, will, in each instance, give somewhat above 14,000,000 heat units.

These results clearly show that if all circumstances as to the production and consumption of heat could have been considered in these experiments the amount of gas used in each case would have been exactly inversely proportional to the heat units contained in the gas. This result could, of course, be expected from the laws of heat, but it is, nevertheless, an interesting fact to have it experimentally demonstrated on a large scale. This result on puddling, and similar results on the consumption of different gases to evaporate water, combined with many other considerations, has led to the important conclusion that it is not advisable to distribute a gas for domestic use with a comparatively low amount of heat units per 1,000 cubic feet. The higher the heat units per 1,000 cubic feet the better, especially when the gas is to be widely distributed.

ITEMS OF INTEREST FROM VARIOUS LOCALITIES.

THE Salem (Mass.) Gas Light Company is soon to occupy its new plant on Bridge street, which is very complete. Mr. John W. Leighton, of Boston, has been chosen President. One particular advantage of the new establishment is the facility with which supplies can be handled.

THE following letter will prove of interest:

SPRINGFIELD GAS AND ELECTRIC LT. CO., }
 SPRINGFIELD, MO., March 7, 1890. }

To the Editor AMERICAN GAS LIGHT JOURNAL:—I notice your remarks in your valuable JOURNAL, of March 3d, about the Laclde Gas Light Company adopting the Coze system of inclined benches. I am pleased to see it because it proves to me that I have not gone far astray in adopting this system here. My excavation is almost ready, and I hope to lay the foundation stone next week, and hope to have the bench under fire at the time of the convention, so that, if it cannot be seen in St. Louis, if the members will come to Springfield I will be glad to see them and show them what I now call improvements upon the original Coze bench in St. Louis. I have had the honor to place the first order for this style of bench with the Laclde Firebrick and Manufacturing Company.

Yours, truly,
 JOHN GIMPER.

AT the annual meeting of the Memphis (Tenn.) Gas Light Company the Directors chosen were Messrs. William A. Williamson, W. S. Bruce, Napoleon Hill, Enoch Ensley, N. M. Jones, John S. Bransford,

and R. Dudley Frayser. This selection shows that Mr. Samuel Prichitt has been succeeded by Mr. Bransford, while Mr. R. D. Frayser takes the place of Mr. Henry Craft. It has been well known for some time that Mr. Prichitt was not enjoying the best of health, but it was hoped by his friends, a wish that was also shared by the stockholders in the Memphis Company, that he would still consent to remain in harness. His declination, however, was positive, and we join with the fraternity in an expression of regret over the first step in his retirement from the active practice of his profession, whose membership will ever hold him in affectionate regard. Mr. N. M. Jones was re-elected President, and Mr. Joseph Craig will also retain the position of Secretary.

WHILE regretting his declination to longer serve on the executive management of the Memphis Company, we are on the other hand able to congratulate Mr. Prichitt on the fact that he is to retain his connection with the Nashville Company, of which enterprise he is virtually part and parcel. The Directors chosen at the last meeting (6th inst.) the Nashville Company are: Messrs. Samuel Prichitt, T. D. Craighead, S. M. Murphy, V. L. Kirkman, Thomas Plater, Jas. Simmons and M. M. Gardner.

JOHN DEVOR, President of the Greenville (O.) Gas Light Company, has made an assignment. Among those who figure on his list of creditors we are sorry to note the name of R. R. Dickey, of Dayton.

FROM a recent issue (6th inst.) of the Chicago Tribune we take the following: "F. M. Charlton, through Beck & Charlton and L. P. Wilcox, solicitors, has filed a bill in the Chancery Court asking for the appointment of a receiver to take charge of the property of the Chicago Gas Trust, to sell its assets, franchises and privileges, and to wind up its affairs, under the direction of the Court. In the meantime it is asked that its officers, directors, agents, and confederates be enjoined from buying or selling the stocks of the associated gas companies, and from exercising any supervision or control over their acts. The grounds are that the Trust is not carrying on the business of manufacturing and selling gas and electricity as it lawfully might, but on the contrary is continually purchasing and selling the stock of the four companies composing it; that it controls their management by holding a majority of the stock of each, and that by its manipulations the interests of the stockholders are suffering. In 1887 the Chicago Gas Trust Company was organized under the general law. Its purposes as set forth in the charter were to build, erect, purchase, lease, establish, maintain, and enlarge works in the city of Chicago and elsewhere for the manufacture, supply, sale, and distribution of gas and electricity, and to purchase and hold the stock, property, plant, and goodwill of other companies. The capital stock was \$25,000,000, consisting of 250,000 shares of \$100 each. Charlton claims that he is a holder of shares in the Trust, which would be of great value to him if the Company would erect the necessary buildings and apparatus for the manufacture and distribution of gas and electricity. He claims that the officers of the Trust never had any intention to carry out the object set forth in the first clauses. On the contrary, it has conspired with the officers of the Chicago Gas Light and Coke Company, the Peoples Gas Light and Coke Company, the Consumers Gas Company, and the Equitable Gas Light and Fuel Company, of Chicago, to control a majority of the shares in each, and thereby to suppress competition, to destroy their diversity of interest, and to build up a monopoly in the manufacture and sale of gas in Chicago. By reason of this combination and conspiracy, and because the Trust does not go ahead and make and distribute gas, Charlton claims that his stock is more than 50 per cent. below par, and is likely to become, through manipulation of the markets, practically worthless. Further, it is set forth that the Trust organized for the purpose of crushing 'competition,' is not only destroying the value of the stock owned by him, but is creating a monopoly dangerous and injurious to the best interests of the people. He claims that under the decision of the Supreme Court, in the case of 'The People, ex rel. Peabody vs. The Chicago Gas Trust Company,' rendered last November, the Trust should be enjoined." Mr. Charlton and his attorneys have managed to put together a goodly share of claptrap in their "complaint."

THE authorities of Salem (Ohio) have determined to abandon the use of incandescent electric lamps for lighting the streets. Arc lights will take their place.

THE shareholders of the Belleville (Ills.) Gas Light and Coke Company and of the Belleville Electric Light and Coal Company will, on April 1st, vote on a proposition to consolidate.

ONE of the Helena (Montana) City Fathers created a hearty laugh in the meeting room a fortnight ago by gravely remarking that the local Gas Company was to be commended for its liberality in reducing the gas rate from \$3 to \$2.50 per gallon. A rather condensed way of putting it.

CONSIDERABLE plant additions will be made to the Omaha (Neb.) Gas Manufacturing Company's system.

DR. MORFIT is responsible for the introduction of an ordinance in the First Branch of the local government of Baltimore to regulate the "laying of gas and other pipes, railroad tracks, electric light, telephone and telegraph wires, in, upon, under or over the streets, lanes and alleys," of the city. Hereafter when any corporation or person is desirous of using the streets for the purposes named they must first obtain written permission from a board, composed of the Mayor, City Commissioner and City Comptroller, to be granted upon such terms and conditions, and subject to the payment to the city for any such privilege of such "equitable sum of money as may be determined by the board." The ordinance was referred, in which state it is hoped it will remain; for, certainly, a rarer gem in the line of a plan for extortion, it has not been our fortune to encounter.

A SUIT for \$5,000 damages has been instituted by Albert I. Thompson against the Worcester (Mass.) Gas Light Company, who asks for this sum because of personal injuries received by him through an explosion of gas on the evening of February 25. Plaintiff alleges that a gas meter had been set in a faulty manner by the agents of the Company in a certain place in the Esterbrook Building, and because of that faulty construction, plaintiff (whose duties obliged him to ignite a match close to the meter) received a severe shock and serious burns in the explosion of gas that followed. Defendant replies that plaintiff acted wrongly in lighting the match, because he must have known that such an act—he was aware that gas was escaping either from the meter or from some break in the service close to it—would imperil his person; also, that if there was a defect in the setting of the meter, it was his or the tenant's place to notify the Company. The case will be tried at the April term of the Superior Court.

THE street lighting service of Lincoln, Neb., calls for the maintenance of 298 gas lamps and 224 gasoline lamps. The city owns all the gas lamps, posts, etc., and the Gas Company furnishes gas and lights and extinguishes, receiving pay therefor at the rate of \$1.75 per lamp per month—moon table. The gasoline lamps, posts, etc., are owned by the contractors, who maintain and repair the same, and also furnish lighting material, and light and extinguish, for the sum of \$1.33½ per lamp per month. The City Engineer estimates that each gas lamp—the city making all needed repairs to same—is a tax on the treasury in the sum of \$2.16½ per month.

THE proprietors of the Helena (Montana) Gas Light and Coke Company have reduced their selling rate from \$3 to \$2.50 per 1,000 cubic feet.

THE City Council of Omaha, Neb., have passed an ordinance creating the office of City Electrician.

THE Boston *Advertiser* says, in a Washington "special," dated the 6th inst.: "The recent Patent Office decision in the interference case of Wm. Stanley, Jr., against M. M. Slattery, better known as the Fort Wayne case, is one of great importance as affecting almost every electric light plant in the United States. The case was one concerning the right to use a converter in electric lighting, each party claiming prior invention of a system in which an adaptation of the converter to the dynamo by the length of its primary coil is a distinguishing element, and one which was not disclosed in some or all the prior publications in evidence. In the Patent Office decision it is held that the entire case turns on the fact that it is not regarded as essential to the invention in issue that in the construction of the converter the length of the primary coil should be made the one variable element to be adjusted to other conditions presented; on the contrary, it is believed to be sufficient to satisfy the terms of the issue that the length of primary coil be suitable to the other conditions presented, whether the length of coil be varied to fit the conditions, or the other conditions are varied to fit the length of the coil. It is thought that if the issue were of narrower construction the primary examiner would have required further terms of limitations to the claims involved. In accordance with this rule, priority of invention was awarded to Stanley, whose patent is the property of the Westinghouse Company."

MR. GEORGE W. MORRIS, President of the Louisville (Ky.) Gas Company, has notified the residents that the Company is ready to distribute

a non-illuminating fuel gas at the rate of 50 cents per 1,000 cubic feet. Perhaps Mr. Barret could be prevailed on to write something for the JOURNAL respecting the fuel gas plans prepared by him for his Company.

THE Fremont (Neb.) City Council has decided to submit a proposition to the people to vote \$10,000 for the construction of a municipal electric lighting station.

MR. THOS. FLANAGAN, has been elected Superintendent of the electrical department of the Portsmouth (N. H.) Gas Light Company. He has practically filled the position for some time past, and is in every sense equipped to carry on the duties of his post.

THE Oswego (N. Y.) Gas Light Company has reduced the gross rate to \$1.85 per 1,000 cubic feet, with 10 cents off for prompt payment, or a net rate of \$1.75. The Company has also notified its consumers that it will hereafter supply incandescent electric lights on an all-night circuit without any change in price of service—60 cents per month for each 16-candle power lamp.

THE following is from the annual report of Mr. W. C. Adams Superintendent of the Richmond (Va.) City Gas Works, respecting the operations of the gas department for the year 1889. Having called attention to the fact that despite the more general use of electricity for illuminating purposes, the receipts for gas were only \$1,832.64 cents less than in 1888, Mr. Adams goes on to say: "I would especially call attention to the limited purifying surface of the works. This is a most important factor in the manufacture of gas, and unless something is done to increase the capacity for purifying we will have serious trouble from impure gas during the next winter. The new retort house containing 10 benches of 6's was completed last April, and the results from these benches have been perfectly satisfactory. The walls of the old retort house were raised 10 feet, and a new roof put on, which conforms the old building to the new, and adds greatly to the comfort of the men. We are still in urgent need of a new holder, and as soon as practicable one should be constructed. The use of the incandescent electric lights reduced the revenue of the department to a slight extent last year, but we are gradually regaining our customers, and I think we will send out more gas in 1890 than in any preceding year since the works were started. I would recommend that efforts be made to increase the consumption of gas by the use of gas stoves. This branch of the business admits of large development and would greatly add to the revenues of the gas department. In Springfield, Mass., over 1,900 heating and cooking gas stoves are now in use. I think the time is near at hand when we will be able to reduce the price of gas to \$1.25 per 1,000 cubic feet. We should at once adopt a graduated scale of prices, by which large consumers could be offered inducements to continue the use of gas, for unless we do we will find that more of our best customers will substitute electricity for gas. It is the large consumers that are leaving us, and we must meet the competition that confronts us, or continue to witness a falling off in our gas receipts."

AT a meeting of the Committee on Manufactures (Massachusetts Legislature), held on the 5th inst., a hearing was had on the petitions of Charles E. Bowers and others and Michael Doyle and others for legislation authorizing cities and towns to manufacture and distribute gas and electricity. Mr. C. P. Greenough appeared for the Boston Gas Light Company, E. W. Burdett for the Massachusetts Electric Light Association, and ex-Senator John C. Crosby for the North Adams Gas Light Company. Mr. Bowers submitted a bill which provides that any city or town may establish or purchase and maintain plants for the manufacture and distribution of gas or electricity for light, heat and power, upon the two-thirds vote of the City Council, in two successive years, in cities, ratified by the people, and in towns by the two-thirds vote of the legal voters at two annual meetings. The bill further provides for the issue of bonds, outside of the limit of indebtedness, the amount of such bonds to be not over 5 per cent. of the town's or city's indebtedness. The plants may be enlarged with the consent of the council or selectmen as above. Assessments may be made upon the owners of premises, but their payment is not obligatory unless gas or electricity is supplied, and the city or town is not to be compelled to furnish gas or electricity to any person or corporation, except by the order of the Gas Commissioners, after proper hearing. The bill provides that the business shall be given in charge of a manager, and that the net profits shall not exceed 8 per cent. Mr. Bowers, in support of his project, referred to the Danvers bill rejected by the Legislature of last year, and read from opinions expressed by the Boston Ex-

Executive Business Association, and various other parties, in favor of municipal control and against corporate monopolies. In Philadelphia, where the price to consumers is \$1.50 per 1,000 feet, the net profit of the municipal gas works in 1888, taking into account what is distributed for city purposes, was \$1,006,134. Included in the Bowers references were extracts from the *Forum*, the *Nationalist*, and the *North American Review*. He said that petitions had been received from between 12,000 and 13,000 people, from 116 towns, in favor of the proposed legislation. Miss L. J. Robinson raised the point that the early laws tended to protect the people in their individual rights, and that they should not be "trampled upon" by corporate monopolies. Frank Parsons favored any bill which should give to each community authority to elect the manner in which gas and electricity should be manufactured and distributed. He claimed that neither corporate monopoly nor private competition could be depended upon in justice to the people, and said that municipal ownership was the only equitable system, as had been shown in the experience of cities which had adopted it. Speaker Barrett appeared in response to the vote of the town of Melrose, which desires to be allowed to manufacture and sell gas and electricity to its inhabitants. Mr. Barret said that there was a feeling in the community, no doubt intensified by the consolidation of the gas and street railway companies, which had increased prices or at least had not diminished prices commensurate with increased advantages, that the different cities and towns should be allowed to choose for themselves in what manner gas and electricity should be manufactured and distributed. This was a question of principle and not one of profit. It did not make any difference whether the town or city made money or not. The only question of importance is whether or not the cities and towns should be allowed this privilege. Mr. Lane and Levi S. Gould, of Melrose, ex-Mayor Raymond, of Salem, P. F. Shevlin, of South Boston, Dr. James Waldock and Frank C. Coffin also addressed the committee either upon the general question or upon some especial or local phase of it. The hearing was then adjourned.

MESSERS. R. D. WOOD & Co., of Philadelphia, Pa., have been awarded the contract for the construction of the new holder at the works of the Citizens Gas Light Company, Newark, N. J.

ALL the preliminaries in respect to the purchase of the Rockford (Ills.) Gas Light Company by the American Gas Company, of Philadelphia, have been completed. The transfer involved the payment of about \$300,000.

WE are in receipt of a copy of a circular recently issued to the gas consumers of Warren, Ohio, by the proprietors of the Warren Gas Light Company, from which we learn that the net rate for gas, from and after the first prox., is to be \$1.50 per 1,000 cubic feet. This is a concession of 30 cents per 1,000, and insures very cheap light to the residents of Warren. This is the fifth reduction that has been made by the Company since 1878, and that it is likely to be tried again is evident from the language of the last paragraph of the circular which reads: "We wish again to impress upon you the fact that the faster the consumption of gas increases in Warren the sooner can the price be further reduced." That the use of gas for purposes other than lighting finds favor in Warren, we may note that over 100 stoves are now in use there.

THE Adams (N. Y.) Gas Light Company has thus perfected its organization: President, N. M. Wardwell; Vice-President, A. B. Hudson; Secretary and Treasurer, E. C. Bessie; Superintendent, R. P. White.

IN the reorganization of the Kenton (O.) Gas and Electric Company the capital stock has been put at \$50,000.

THE capital stock of the Toraya (Philadelphia) Patent Gas Company is \$20,000, and the original Board of Directors comprised Messrs. Jose F. Toraya, Jose Vivo and Chas. C. Haines.

THE electric light plant recently determined upon by the proprietors of the Johnstown (N. Y.) Gas Company is being installed.

AT a meeting of the Troy (N. Y.) Contracting Board, the subject under consideration being the bids for public lighting, City Engineer Fuller moved that the contract for street electric lighting be awarded to the Troy Gas Company, for 5 years, at 39½ cents per light per night, for lights of 2,000-candle power. The motion was adopted. Comptroller Roche then moved that the Troy Electric Light Company be authorized to keep on with the public lighting at the ruling figure of 43½ cents per night for each lamp until the Gas Company is ready to go on with the

new contract. There is small doubt that the Gas Company will soon absorb its rival.

AT a meeting of the Directors of the National Gas and Electrical Construction Company, Boston, Mass., Benjamin F. Butler was elected President, and Fred. Whittemore, Clerk.

AT a meeting of the Engineers' Club (Philadelphia, Pa., March 1) Mr. Henry G. Morris described a new method of sinking dies, and followed his remarks by presenting a beautiful specimen of the results accomplished. He stated that these results could be obtained by this process at a cost entirely insignificant when compared with the cost by the old method.

THE City Council of Macon, Ga., has decreed that the electric lighting towers (6 in all, 150 feet each in height, and erected at a cost of \$5,000) must be torn down by May 1st. The reason given is that the "towers are dangerous."

C. O. FRENCH, Solicitor for the Utah, Nevada and San Francisco Railroad, has applied to the City Council, of Salt Lake, for a franchise for the construction and operation of a gas plant. He proposes to supply illuminating gas for \$2 and heating gas for \$1 per 1,000 cubic feet. While not positive about the matter, we are inclined to think that French is backed by certain parties who are interested in the Jackson (Mich.) plant.

Economy of Fuel in the Distillation of Ammoniacal Liquor.

In these days of small margins of profit the manufacturer can no longer afford to throw anything away until he is quite certain that its capacity as a revenue producer is exhausted. Applying this principle to the distillation of ammoniacal liquor in the column still, says the *Chemical Trades' Journal*, one is struck by the fact that in the process as ordinarily conducted the spent liquor leaves the still at a boiling temperature, containing the heat equivalent of a considerable quantity of fuel. These few remarks are intended to show how, in the case of the Davis still, this heat may be recovered and utilized. In the case of the Davis still the spent liquor escapes from the apparatus through a series of U-tubes. It is proposed to cause these U-tubes to pass through a water-tight box of any convenient shape and material, and the ammoniacal liquor to be treated is conducted through this box on its way to the still, so that it becomes heated by contact with the U-tubes, through which the spent liquor is escaping. In one works this arrangement has been already adopted, and answers very successfully. The temperature of the ammoniacal liquor is raised to 108° F., while the spent liquor only registers 112° F. as it escapes to the drain. Where other means are adopted for the pre-heating of the ammoniacal liquor, the "Economiser" (as the apparatus is called) may be employed to heat water for the boiler supply, or for any other purpose. In certain cases it may be desirable to substitute a coil of pipes for the series of U-tubes, but if this is done care must be taken to so arrange the coil that it forms a seal equivalent in its effect to the U tubes. These outlet tubes or coils may be best cleaned out by connecting temporarily with a high pressure water supply, communication with the still being, of course, cut off while the flushing or cleansing operation is going on. A mixed jet of steam and water, where it can be got, answers this purpose very effectually.

It may be thought by some that the saving to be effected by the use of the "Economiser" is insignificant. Compared with the differences between "ancient" and modern stills, this saving may appear a small one; but it must be remembered that the field of the economist is much more restricted in its area than was the case some few decades ago. We are very much nearer the goal of theoretical perfection, and our rate of progress must be expressed in smaller units. Those manufacturers who fail to appreciate small individual improvements are considerable losers in the aggregate, and are among the first to drop out from the struggle where the fittest only survive. The proverbial sweetness of little fishes has its parallel in the acceptableness of small economies.

The Market for Gas Securities.

The city share market during the week has remained in a quiet state, but the undertone is all in favor of higher prices. There was no considerable variation in values, and the trading was light. In connection with the purchase of the artificial lighting and gas fuel supply of Indianapolis, Ind., we note a rather curious denial by President Graham, of the Equitable Company of this city, who wishes it distinctly understood that that Company as a Company had nothing to do with the purchase. No one really supposed that such was the case; but we presume it was pardonable to infer (from the fact that a circular calling attention to the purchase was dated from the Company's office on Third avenue) that some of its directors were interested in the transfer.

Rumors are rife that the Citizens Company, of Brooklyn, will be called to account by the Fulton Municipal Company, in respect to the proposition of the owners of the former that they think it is time to make gas instead of peddling it. The increase to the Company's stock has been sanctioned by the required assent of the stockholders. Nassau gas is steady, at 120 to 122, the certificates being quoted at par to 107,

Gas Stocks.

quotations by Geo. W. Close, Broker and Dealer in Gas Stocks,

16 WALL ST., NEW YORK CITY.

MARCH 17.

All communications will receive particular attention.
The following quotations are based on the par value of \$100 per share.

	Capital.	Par.	Bid	Asked
Consolidated.....	\$35,430,000	100	95 $\frac{1}{2}$	96 $\frac{1}{2}$
Central.....	500,000	50	—	—
“ Scrip.....	220,000	—	—	—
Equitable.....	4,000,000	100	119	122
“ Bonds.....	1,000,000	—	113	115
Harlem, Bonds.....	170,000	—	—	—
Metropolitan, Bonds....	658,000	—	116	118
Mutual.....	3,500,000	100	110 $\frac{1}{2}$	—
“ Bonds.....	1,500,000	—	100	102
Municipal, Bonds.....	750,000	—	—	—
Northern.....	—	50	—	—
“ Bonds.....	150,000	—	—	100
Standard Gas Co.—				
Common Stock.....	5,000,000	100	—	45
Preferred.....	5,000,000	100	84	87
Yonkers.....	—	50	112	—
Richmond Co., S. I....	346,000	50	—	—
“ Bonds.....	20,000	—	—	—
Gas Co's of Brooklyn.				
Brooklyn.....	2,000,000	25	109	111
Citizens.....	1,200,000	20	—	68
“ S. F. Bonds....	320,000	1000	102	103
Fulton Municipal.....	3,000,000	100	123	—
“ Bonds....	300,000	—	105	—
Peoples.....	1,000,000	10	80	—
“ Bonds (5's).....	368,000	—	100	—
“ “ (6's).....	94,000	—	100	—
Metropolitan.....	1,000,000	100	—	100
Nassau.....	1,000,000	25	120	122
“ Ctfs.....	700,000	1000	100	102
Williamsburgh.....	1,000,000	50	124	—
“ Bonds... ..	1,000,000	—	108	112
Out of Town Gas Companies.				
Boston United Gas Co.—				
1st Series S. F. Trust	7,000,000	1000	93	93 $\frac{1}{2}$
2d “ “ “	3,000,000	1000	71	72
Bay State Gas Co.—				
Stock.....	5,000,000	50	24	25
Income Bonds.....	2,000,000	1000	—	—
Buffalo Mutual, N. Y... ..	750,000	100	90	95
“ Bonds... ..	200,000	1000	95	100
Citizens, Newark.....	1,000,000	50	155	160
“ “ Bonds.	45,000	—	—	—
Chicago Gas Trust.....	25,000,000	100	42 $\frac{1}{4}$	42 $\frac{3}{4}$
Chicago Gas Light & Coke Co.—				
G't'd Gold Bonds	7,650,000	1000	—	93 $\frac{1}{2}$
Equitable Gas & Fuel Co., Chicago, Bonds	2,000,000	1000	97	—
People's Gas and Coke Co., Chicago—				
1st Mortgage.....	2,100,000	1000	—	99
2d “	2,500,000	1000	96	100
Consumers Gas Light Co., Jersey City.....	2,000,000	100	15	25
Bonds.....	600,000	1000	80	—
Cincinnati G. & C. Co..	6,000,000	100	201	203
Consumers Toronto....	1,000,000	50	190	200
Central, S. F., Cal.....	—	80	90	—
Capital, Sacramento, Cal	—	58	—	—
Consolidated, Balt.....	11,000,000	100	54	54 $\frac{1}{4}$
“ Bonds.....	6,400,000	—	107	107 $\frac{1}{2}$
Citizens Gas Lt. Co., Rochester, N. Y.....	500,000	—	75	90
Bonds.....	250,000	—	—	—
Hartford, Conn.....	750,000	25	102	108
Jersey City.....	750,000	20	186	190
Laclede Gas Light Co., St. Louis, Mo.—				
Common Stock....	7,500,000	100	15	17
Preferred “	2,500,000	100	—	—
Bonds.....	9,034,400	1000	84 $\frac{1}{2}$	—

Louisville, Ky.....	2,570,000	50	125	130
Little Falls, N. Y.....	50,000	100	—	100
“ Bonds	25,000	—	100	103
Montreal, Canada.....	2,000,000	100	200	208
Memphis (Tenn.) Gas... ..	750,000	100	48	51
“ Bonds.	240,000	100	103	—
New Haven, Conn.....	—	25	200	—
Oakland, Cal.....	—	—	35	35 $\frac{1}{2}$
Peoples, Jersey City... ..	—	—	60	61
“ “ Bonds..	—	—	—	—
Paterson, N. J.....	—	25	99	102
Rochester, N. Y.....	—	50	99	100
Syracuse, N. Y.....	500,000	25	—	—
San Francisco Gas Co.	—	—	—	—
San Francisco, Cal....	10,000,000	100	55 $\frac{1}{2}$	55 $\frac{3}{4}$
Washington, D. C.....	2,000,000	20	200	208
Wilmington, Del.	—	50	88	90

Advertisers Index.

	Page
GAS ENGINEERS.	
Jos. R. Thomas, New York City.....	380
Wm. Henry White, New York City.....	383
Wm. Mooney, New York City.....	380
William Gardner, Pittsburgh, Pa.....	380
Fred. Bredel, N. Y. City.....	379
GAS WORKS APPARATUS AND CONSTRUCTION.	
James R. Floyd & Sons, New York City.....	383
Continental Iron Works, Greenpoint, L. I.....	383
Deily & Fowler, Phila., Pa.....	383
Kerr Murray Mfg. Co., Fort Wayne, Ind.....	371
Stacey Mfg. Co., Cincinnati, Ohio.....	383
Bartlett, Hayward & Co., Baltimore, Md.....	381
Morris, Tasker & Co., Limited, Phila., Pa.....	381
Davis & Farnum Mfg. Co., Waltham, Mass.....	371
R. D. Wood & Co., Phila., Pa.....	382
Bouton Foundry Co., Chicago, Ills.....	383
Smith & Sayre Manufacturing Co., New York City.....	382
Fred. Bredel, N. Y. City.....	379
United Gas Improvement Co., Phila., Pa.....	573
National Gas Light and Fuel Co., Chicago, Ills.....	371
Simpkin & Hillyer, Richmond, Va.....	367
GAS AND WATER PIPES.	
Gloucester Iron Works, Phila., Pa.....	380
Mellert Foundry and Machine Co., Reading, Pa. (John Fox, Selling Agent, N. Y.).....	380
Ohio Pipe Co., Columbus, Ohio.....	380
M. J. Drummond, New York City.....	380
R. D. Wood & Co., Phila., Pa.....	382
Warren Foundry & Machine Co., New York City.....	380
Donaldson Iron Co., Emaus, Pa.....	380
Dennis Long & Company, Louisville, Ky.....	380
PROCESSES.	
National Gas Light and Fuel Co., Chicago, Ills.....	374
Bartlett, Hayward & Co., Baltimore, Md.....	381
Wm. Henry White, N. Y. City.....	383
United Gas Improvement Co., Phila., Pa.....	373
The Fuel Gas and Light Improvement Co., N. Y. City.....	368
INCLINED RETORTS.	
Laclede Fire Brick Manuf'g Co., St. Louis, Mo.....	335
GASHOLDER TANKS.	
W. C. Whyte, New York City.....	374
J. P. Whittier, Brooklyn, N. Y.....	375
GASHOLDER PAINT.	
The Government Waterproof Paint Co., Boston, Mass.....	367
RETORTS AND FIREBRICK.	
J. H. Gantler & Co., Jersey City, N. J.....	378
B. Kreischer & Sons, New York City.....	378
Adam Weher, New York City.....	378
Laclede Fire Brick Manuf'g Co., St. Louis, Mo.....	378
Brooklyn Retort and Fire Brick Works, Brooklyn, N. Y.....	378
Borgner & O'Brien, Phila., Pa.....	378
James Gardner, Jr., Pittsburgh, Pa.....	378
Henry Maurer & Son, New York City.....	379
Chicago Retort and Fire Brick Co., Chicago, Ills.....	378
Baltimore Retort and Fire Brick Co., Baltimore.....	378
Oakhill Gas Retort and Fire Brick Co., St. Louis, Mo.....	378
SCRUBBERS AND CONDENSERS.	
G. Shepard Page, New York City.....	386
R. D. Wood & Co., Phila., Pa.....	382
REGENERATIVE FURNACES.	
Bartlett, Hayward & Co., Baltimore, Md.....	381
Fred. Bredel, New York City.....	379
Chicago Retort and Firebrick Co., Chicago, Ills.....	378
Wm. Henry White, N. Y. City.....	383
J. H. Gautier & Co., Jersey City, N. J.....	379

GAS GOVERNORS.

Connelly & Co., New York City.....	375
Fred. Bredel, N. Y. City.....	379
Friedrich Lux, London, England.....	368
SELF-SEALING MOUTHPIECE DOORS.	
Smith & Sayre Mfg. Co., New York City.....	382
TAR AND CARBONIC ACID EXTRACTOR.	
Geo. Shepard Page, N. Y. City.....	372
CEMENTS.	
C. L. Geronid & Co., Brooklyn, N. Y.....	378
GAS ENRICHERS.	
Standard Oil Co., Cleveland, Ohio.....	384
GAS METERS.	
John J. Griffin & Co., Phila., Pa.....	386
American Meter Co., New York and Philadelphia.....	387
The Goodwin Gas Stove and Meter Co., Philadelphia, Pa.....	387
Helme & McIlhenny, Phila., Pa.....	387
D. McDonald & Co. Albany, N. Y.....	387
Nathaniel Tufts, Boston, Mass.....	386
Maryland Meter and Manufacturing Co., Baltimore, Md.....	385
Beil & Jones, Philadelphia, Pa.....	386
EXHAUSTERS.	
The P. H. & F. M. Roots Co., Connersville, Ind.....	370
Smith & Sayre Manufacturing Co., New York City.....	382
Wilbraham Bros., Philadelphia, Pa.....	375
Connelly & Co., New York City.....	375
GAS COALS.	
Penn Gas Coal Co., Phila., Pa.....	385
Perkins & Co., New York City.....	384
Newburgh Orrel Coal Co., Baltimore Md.....	385
Despard Coal Co., Baltimore, Md.....	385
Chesapeake and Ohio R. Coal Agency, N. Y. City.....	385
Westmoreland Coal Company, Phila., Pa.....	385
J. & W. Wood, New York City.....	384
CANNEL COALS.	
Perkins & Co., New York City.....	384
J. & W. Wood, New York City.....	384
VALVES.	
Ludlow Valve Manufacturing Co., Troy, N. Y.....	376
John McLean, New York City.....	376
Chapman Valve Manufacturing Co., Boston, Mass.....	376
R. D. Wood & Co., Phila., Pa.....	382
The P. H. & F. M. Roots Co., Connersville, Ind.....	370
GAS ENGINES.	
Schleicher, Schumm & Co., Phila., Pa.....	352
Clerk Gas Engine Co., Phila., Pa.....	376
Van Duzen Gas Engine Co., Cincinnati, Ohio.....	376
ENGINES AND BOILERS.	
Jarvis Engineering Co., Boston, Mass.....	375
Ball Engine Co., Erie, Pa.....	367
Westinghouse Machine Co., Pittsburgh, Pa.....	379
GAS LAMPS.	
G. Shepard Page, New York City.....	376
Welshach Incandescent Gas Light Co., Phila., Pa.....	369
The Siemens-Lungren Company, Philadelphia, Pa.....	369
PURIFIER SCREENS.	
John Cabot, New York City.....	376
Bartlett, Hayward & Co., Baltimore, Md.....	376
GAS STOVES.	
American Meter Co., New York and Philadelphia.....	377
The Goodwin Gas Stove and Meter Co., Phila. Pa.....	388
George M. Clark & Company, Chicago, Ills.....	369
D. McDonald & Co., Albany, N. Y.....	387
Maryland Meter and Manufacturing Co., Baltimore, Md.....	386
Bell & Jones, Philadelphia, Pa.....	386
Chicago Gas Stove Company, Chicago, Ills.....	367
STREET LAMPS.	
J. G. Miner, Morrisania, New York City.....	332
Bartlett Street Lamp Man'g Co., New York City.....	367
BURNERS.	
C. A. Gefroerer, Phila., Pa.....	384
H. W. Rappleye, Philadelphia, Pa.....	368
STEAM BLOWER FOR BURNING BREESE.	
H. E. Parson, New York City.....	340
PURIFYING MATERIAL.	
Connelly & Co., New York City.....	375
Friedrich Lux, London, England.....	368
Edgewater Lime Works, Edgewater, N. J.....	368
COKE CRUSHER.	
C. M. Keller, Coiumbus, Ind.....	385

ELECTRICAL APPARATUS.

Wm. Henry White, N. Y. City 383

SOLVENTS.

Maas & Waldstein, New York City..... 375

BOOKS, ETC.

Gerould's System Gas Bookkeeping..... 368
 1889. Directory. 1889 378
 King's Treatise 386
 Scientific Books. 350
 Management of Small Gas Works 376
 Gas vs. Electricity 332
 Practical Electric Lighting..... 375
 Electric Light Primer..... 373
 American Gas Engineer and Superintendents' Handbook... 385
 Digest of Gas Law..... 367
 Fuel and its Applications 367
 Newblgging's Handbook..... 379

**WANTED,
 Management of Gas Works.**

By practical gas man of many years' experience. Is master of all branches of work about a small plant—main laying, services, retort setting, gasfitting, or repairs about the works. Best of references. 771-2 Address "W," care this Journal.

POSITION WANTED.

A Mechanical Engineer,

Experienced in Gas Manufacture, wishes a position as Superintendent of a Gas Works. Best of references given and asked. Salary, \$1,200.

"MECHANICAL ENGINEER," care this Journal, 765-tf or Box 972, West Bay City, Mich

Position Wanted

As Superintendent or Assistant of a Gas Works,

By a man who can give the best of references. Thoroughly understands the manufacture and distribution of gas and the construction of works. Address 770-3 "M.," care this Journal.

FOR SALE,

The Ironwork for 11 Benches of 5's, viz.:
 Cast Iron Hydraulic Mains, 17 Inch diameter, Inside.
 Dip Pipes, Bridge Pipes, Stand Pipes.
 Mouthpieces and Lids.
 Four Purifiers, 10 by 16 ft., with 10-inch Connections and dry Center Seal.
 Four Purifiers, 5½ by 10 ft., with 6-inch Connections and Wet Center Seal.
 Valves, 6-inch, 8-inch, and 10-inch.
 DAVID MOORE, Treas. Salem Gas Lt. Co.,
 770-tf Salem, Mass.

GAS WORKS FOR SALE.

A CONTROLLING INTEREST IN SEVERAL

Interior California Coal Gas Plants,

now paying handsomely, are offered on very reasonable terms. This is an exceptionally good opportunity for practical gas men of limited means, wishing to remove to a mild and healthful climate, to acquire an established and paying business. Particulars given and full investigation solicited.

SECRETARY, 123 Beale Street, San Francisco, Cal. 760-3 mos.

FOR SALE.

A Complete Water Gas Plant.

60,000 Cu. Ft. Daily Capacity.

Fully equipped; all the latest improvements; includes Generator, Purifiers, and Holder. Can be removed to any part of the country, and set up at small cost. For further information apply to BRADFORD GAS LT. & HEATING CO., Dunkirk, N. Y.

6 PER CENT.

First Mortgage Bonds

ON GAS WORKS

SITUATED IN GROWING WESTERN TOWNS.

Principal and Interest Guaranteed.

INTEREST SEMI-ANNUALLY.

For sale by the undersigned, who will furnish all necessary information regarding them.

JOS. R. THOMAS, 42 Pine St., N. Y. City.

Fuel and Its Applications.

By E. J. MILLS, D.Sc F.R.S., and F. J. ROWAN, C.E., assisted by others, including Mr. F. P. Dewey, of the Smithsonian Inst., Wash., D. C.

7 PLATES, AND 607 OTHER ILLUSTRATIONS. ROYAL OCTAVO. PAGES XX. 802. HANDSOME CLOTH, \$7.50.

A. M. CALLENDER & CO., 42 Pine St., N. Y.

Simpkin & Hillyer

RICHMOND, VA.

MANUFACTURERS OF

Gas Works Apparatus

BENCH CASTINGS, CONDENSERS,

Scrubbers, Purifiers, Dry Center Seals,

FOUR-WAY VALVES, GAS VALVES,

SULPHATE OF AMMONIA APPARATUS,

TANKS, ENGINES, BOILERS,

PUMPS, ETC., ETC.

Plans, Specifications and Estimates furnished for new works, or alteration of old works. Correspondence solicited. Works. Newport News, Va.

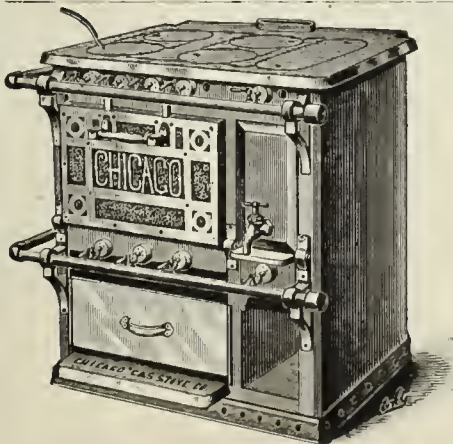

CHICAGO GAS STOVE CO.

MANUFACTURERS OF ALL KINDS OF

Gas Cooking and Heating

APPLIANCES.

117-119 Lake St., CHICAGO.

Send for Catalogue.

GASHOLDER PAINT.

Use Only

THE GOVERNMENT WATERPROOF PAINT.

Proof against Ammonia, and Absolutely Waterproof. Send for Prices and Particulars.

THE GOVERNMENT WATERPROOF PAINT CO., 122 Milk Street, Boston, Mass.

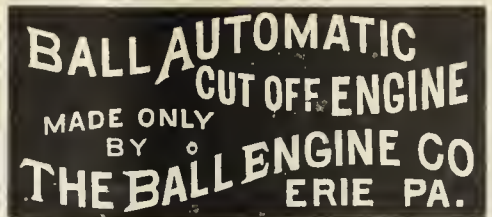

Bartlett Street Lamp Mfg. Co.

MANUFACTURERS OF

Globe Lamps,

FOR

Streets, Parks, Public Buildings, Railroad Stations, etc.

LAMP POSTS

A Specialty.



Office and Salesroom,

40 & 42 COLLEGE PLACE, - - N. Y. CITY.

Gas Companies and others intending to erect Lamps and Posts will do well to communicate with us.

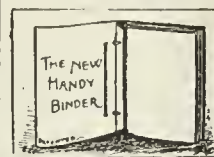

**THE NEW
 HANDY BINDER.**

This article may be described as elegant in appearance, strong, durable, and possessing many special qualities of its own. It allows the opening of the pages perfectly flat, whether one or several numbers are in the binder. Any number can be taken out and replaced without disturbing the others. The papers are not mutilated for subsequent binding in permanent form. The binder is supplied with gilt side title, and is an ornament to any desk or reading table. The JOURNAL, filed in the Handy Binder, becomes a volume of great value, always convenient for instant reference. Handy Binder, Postage paid, \$1.00.

A. M. CALLENDER & CO., 42 Pine St., N. Y.

GREENOUGH'S

"DIGEST OF GAS LAW."

Price, \$5.00.

This is a valuable and important work, a copy of which should be in the possession of every gas company in the country, whether large or small. As a book of reference it will be found invaluable. It is the only work of the kind which has ever been published in this country, and is most complete. Handsomely bound. Orders may be sent to

A. M. CALLENDER & CO.,
 42 Pine Street, N. Y.

RAPPLEYE'S RHEOMETRIC GOVERNOR BURNER.

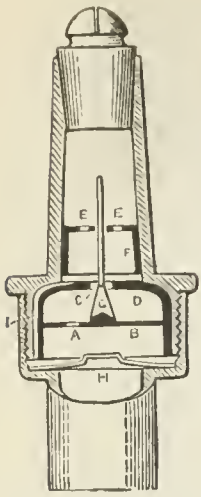

EXPLANATION OF CUT.—Gas passes through opening *A* in piston *B*, thence through opening *C* in inverted cup *D*, and through openings *EE* in guide-plate *F*; the flow being governed by the position of the conical valve *G* in respect to the opening *C*, a position which is automatically regulated by variations in the pressure of gas on piston *B*. Thus, if the pressure is excessive, the piston will be forced upward and the valve *G* elevated so as to restrict the freedom of the flow through opening *C*, the piston descending and the valve opening as the pressure is diminished.

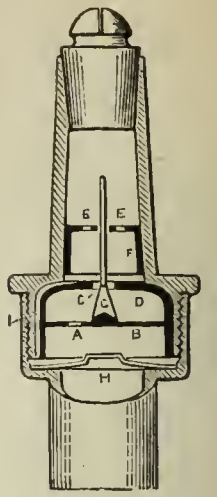

This Burner is a Perfect Pressure Regulator, maintaining a uniform pressure at point of ignition at any pressure above $\frac{1}{8}$ in.

Careful Photometric tests show a gain of *fifteen per cent.* in illuminating power *over* the Argand burner. Warranted to give the same amount of light as other burners at from 25 to 50 per cent. less cost, and not to corrode or clog in any manner.

Manufactured in 2, 3, 4, 5, 6, 7, and 8 ft. sizes, and larger or smaller or intermediate fractional sizes to order.

Price, \$6 per Dozen. Special Price and Free Sample to Gas Light Companies on Application.

In ordering Burners state whether for Coal Gas, Water Gas, Oil Gas, or Natural Gas; and also give specific gravity and illuminating power of same. Special Burners will be adjusted on demand for any quality of gas, and warranted to consume any required amount of such gas.

OFFICE OF THE SUPERINTENDENT OF THE CITY GAS WORKS, }
RICHMOND, VA., March 10th, 1890. }

MR. H. W. RAPPLEYE, 1345 Arch Street, Philadelphia:

Dear Sir—In answer to your inquiry concerning your Burners, I will say that since the introduction of your Burners on our street lamps, about four years ago, they have given perfect satisfaction in every particular. I cannot recall a single instance where one had to be replaced for any defect whatever.

Very truly yours,

WM. C. ADAMS, Supt.

ARE YOU USING RAPPLEYE'S RHEOMETRIC GOVERNOR BURNERS? IF NOT, WHY NOT?

F. D. HARMON, PRES.

CHAS. C. ALLEN, SEC. AND TREAS.

P. W. MACKENZIE, CHIEF ENGR. & SUPT.

THE FUEL GAS AND LIGHT IMPROVEMENT CO. OF AMERICA.

Owner of the Mackenzie Patents of Dec. 31, 1889,

For the United States, England, Russia, France, Germany, Austria, and Canada,

No. 32 Park Place, New York City.

This SYSTEM is an ABSOLUTELY NEW DEPARTURE IN THE MANUFACTURE OF FUEL AND ILLUMINATING GAS. The COST OF GAS IN THE HOLDER by our System is at least THIRTY PER CENT. LESS than that made by any other process of the day. The Gas contains neither SULPHUR nor other impurities, nor is there any resultant LAMPBLACK OR TAR RESIDUUM.

The Gas is manufactured WHOLLY from LIQUID HYDROCARBONS, such as Lima, Penn. Crude, and Fuel Oils, Naphtha, etc. Neither PERISHABLE PIPES nor other RETORTS, NOR THEIR EQUIVALENTS, are used. The Gas requires NO PURIFICATION. Neither COAL, COKE, nor any other HARD CARBONS enter into the manufacture or composition of the Gas, thereby requiring LESS LABOR THAN ANY OTHER METHOD. The APPARATUS is extremely SIMPLE, SUBSTANTIAL, and DURABLE.

Works under our system can be CONTINUOUS or ALTERNATING. If alternating, the Nitrogen present will be less than $4\frac{1}{2}$ per cent. If continuous, the limited amount of Nitrogen present is neutralized by Carbon.

One gallon of Lima oil by our process EQUALS ALL THE COAL required for making 1,000 feet of carbureted Water Gas.

GEROULD'S
System Gas Bookkeeping.

Approved and adopted by many of the prominent Gas Engineers of the Country.

Sample Sheets and Price-List furnished free on application to

L. P. GEROULD, - - Mendota Ill.

FRIEDRICH LUX,

Ludwigshafen am Rhein and London.

Lux Mass

GAS GOVERNORS,

Gas Balance.

EDGEWATER LIME WORKS

Chas. F. McKenna, Proprietor.

SHELL LIME.

Lime by the Cargo for Gas Purification.

EDGEWATER, BERGEN CO., N. J.

Write for Testimonials and Prices.

The Gordon Portico Lamp.

A successful Competitor of the Arc Electric Light for lighting Store Fronts, Show Windows, Depots, Railway Sheds, etc., etc.

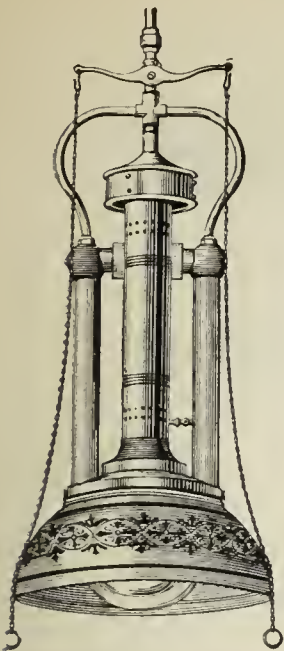

Gordon Portico Lamp.

The Gordon Street Lamp.

A Successful Competitor of the Arc Electric Light for lighting Streets, etc., etc.

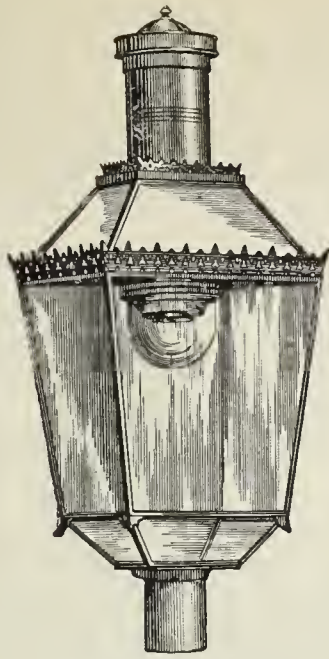

Gordon Street Lamp.

The Lungren Lamp.

A Successful Competitor of the Incandescent Electric Light for Interiors, etc. Is especially applicable for the lighting of Offices, Stores, Factories, Mills, Show Windows, Libraries, and all situations where an increased illumination is desired.

More than 25,000 Lungren Lamps are now in use. Testimonials, references, or any desired information will be cheerfully given.



Lungren Lamp.

THE SIEMENS-LUNGREN CO., N.E. Cor. 21st St. & Washington Av., PHILADELPHIA.

WELSBACH SYSTEM OF Incandescent Gas Lighting.

OFFICE, DREXEL BUILDING, PHILA., PA.

At the Fall Session of the Board of Supervisors of Winnebago County, held at the County Court House, Oshkosh, Wis., Nov. 26, 1889, the report submitted by Mr. C. W. Cook, Chairman of the Committee on Public Buildings, recommending the use of the Welsbach Incandescent Gas Burner in the Buildings under their charge, was unanimously adopted, because of the extreme economy in the consumption of Gas and the superior character of the light obtained.

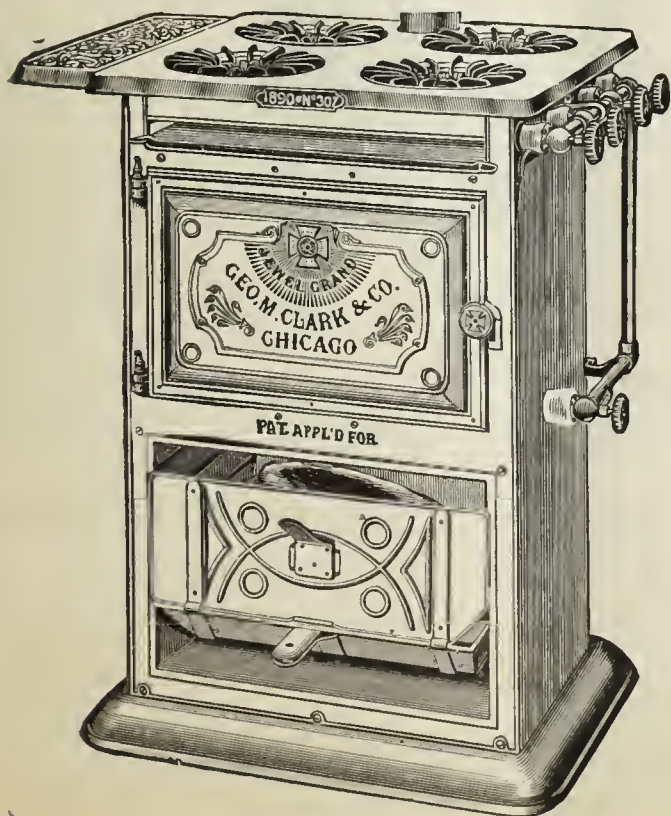

JEWEL GAS STOVES

MANUFACTURED BY

GEORGE M. CLARK & COMPANY,

Nos. 157 & 159 Superior Street, - - - Chicago, Ill.

EVERY CONCEIVABLE SIZE AND STYLE,

Ranging in Prices from \$1.50 to \$30.00.

WE USE NO GAS COCKS.

All Flames are Regulated by a Direct Needle Valve.

The JEWEL

IS THE

Only Well-Made Gas Stove on the Market.

Write for our 1890 Catalogue and see for yourself.



ROOTS' NEW GAS EXHAUSTER.

Unsurpassed
for Neatness
of Design,
Durability,
Simplicity,
Efficiency,
and Economy
of Power.

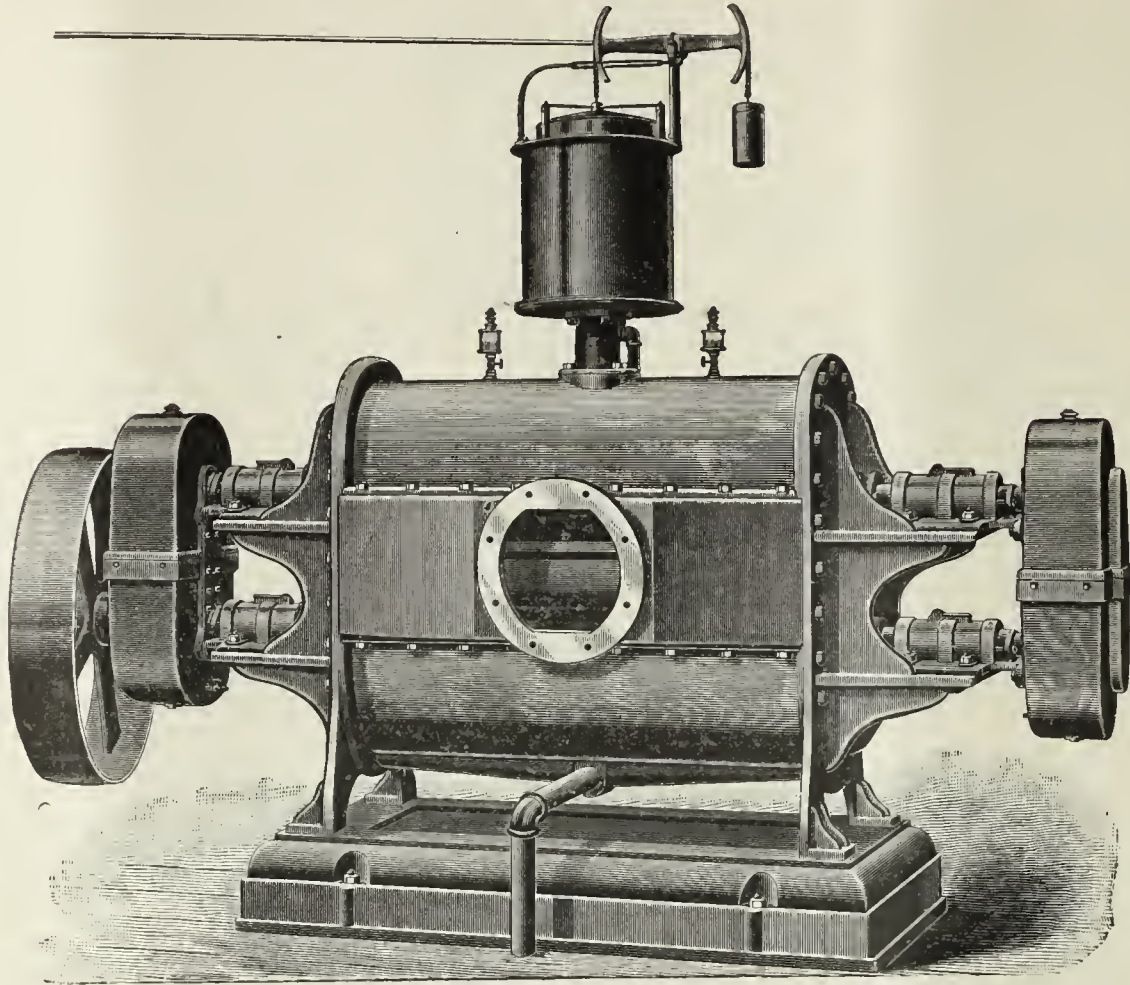

All Parts
Requiring
Attention
are External
and Easily
Accessible
at all Times.

ROOTS' GAS AND BYE-PASS VALVES.

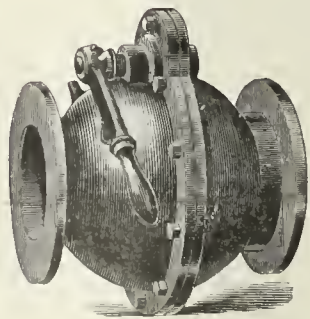

GAS VALVE

Quick Acting,
Simple,
Efficient, Durable.

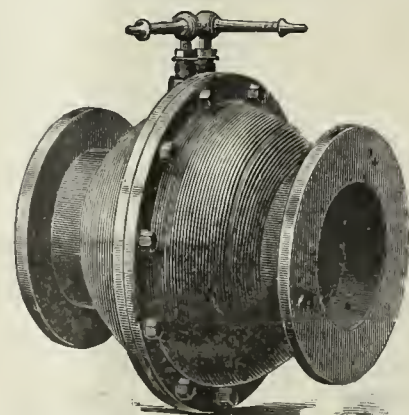

BYE-PASS VALVE.

Automatic Action,
Reliable,
Simple, Durable.

Thousands now in use and giving perfect satisfaction. Write for Catalogue and Prices.

Send for Descriptive Catalogue and Price List.

THE P. H. & F. M. ROOTS CO., Patentees and Manufacturers, **CONNERSVILLE, IND.**

S. S. TOWNSEND, Gen. Agt., 22 Cortlandt St., N. Y.

COOKE & CO., Selling Agts., 22 Cortlandt St., N. Y.

THIS SPACE
WILL BE
Occupied Next Month by the
KERR MURRAY MFG. CO.
FORT WAYNE, IND.
**GAS WORKS
APPARATUS
AND
HOLDERS.**

DAVIS & FARNUM MFG. CO., WALTHAM, MASS.

PRINCIPAL OFFICE AND WORKS, Waltham, Mass.

BOSTON OFFICE, Room 55, Mason Building, 70 Kilby Street.

SINGLE, DOUBLE,
AND
TRIPLE LIFT

Gasholders.

OF ANY CAPACITY.

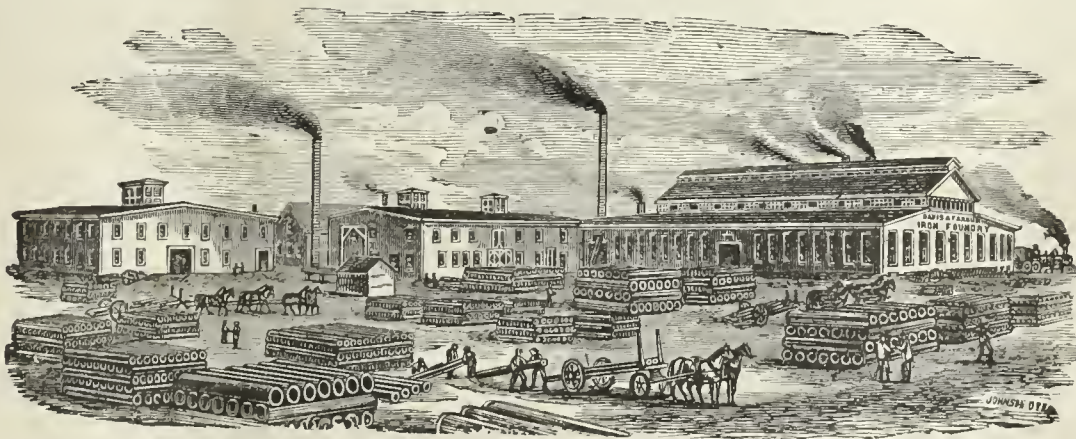

TUBULAR, PIPE,
AND
SINUOUS FRICTION

Condensers.

OF ALL SIZES.

IRON ROOF FRAMES AND FLOORS.

Purifying Boxes, Center Seal or Valve Connections, Bench Work.

Reversible Lime Trays.

SELF-SEALING AND PRESSED STEEL MOUTHPIECE LIDS.

Coke Barrows, Coal Wagons, and all Apparatus Requisite for a Complete Gas Plant.

— ALSO —

Gas and Water Pipe, Flanged Pipe,

Sugar House Work, and Special Castings of all Descriptions.

THE WALKER TAR AND CARBONIC ACID EXTRACTOR.

A very general demand exists, in both large and small Gas Works, for an apparatus that will be absolutely efficient in the removal of the tar which passes the hydraulic main and condenser. Many attempts have been made to accomplish this, but, I believe, without success, until the introduction, five years ago, in England, of the C. & W. Walker Patent Tar and Carbonic Acid Extractor. During these years this apparatus has been adopted by many of the most prominent Engineers, not only in England, but also on the Continent of Europe and in other parts of the world. It is only necessary to give here a partial list in order to convince any intelligent American Gas Engineer that this machine must have succeeded fully in accomplishing the desired results.

The following Engineers have personally given permission to refer to them:

G. C. Trewby, Esq., Engineer-in-Chief of the Gas Light and Coke Co., London. The manufacturing plant at Beckton is built in complete sections of 3,000,000 cubic feet capacity each. A Walker Tar Extractor has been fitted to each one of these sections. This was done after a long and thorough trial on one of its sections. The Tar Extractor has been supplied to other works of the Gas Light and Coke Co., including those of which John Methven, Engineer of the Gas Light and Coke Co. at the Nine Elms Station, is in charge. Also to G. E. Stevenson, Peterborough Gas Works; B. Green, Mitcham and Wimbledon Gas Works; W. H. Smith, Bedford Gas Works; F. Linging, Norwich Gas Works; J. T. Browning, Colchester Gas Works; S. B. Darwin, Portsmouth Gas Works; J. McCrae, Dundee Gas Works; W. J. Wells, Stamford Gas Works; J. M. Darwin, Longton Gas Works; J. Paterson, Warrington Gas Works; and J. Coulter, of the Dundalk Gas Works. All of the foregoing gas works are located in Great Britain.

Mr. Charles A. Gerdenier, Superintendent of the Bridgeport (Conn.) Gas Light Company, writes as follows, under date of Dec. 3, 1887:

"The C. & W. Walker Tar and Carbonic Acid Extractor has been in operation at these works for the past six weeks, and is an unqualified success. It removes every particle of Tar from the gas in once passing through the apparatus, and a large percentage of the Carbonic Acid. I also feel quite sure that it prevents the formation and deposit of Naphthaline, because since I started the Washer I have had no stoppages from this cause. These works have been seriously troubled with Tar for many years, and I have used several kinds of apparatus and every expedient which has come to my attention for dealing with the difficulty, but without success. The Walker apparatus occupies comparatively small space, is less expensive than other systems, and requires but little attention. I carry 2½-inch seal, and have an automatic tar delivery valve. This Tar Extractor is indispensable to gas makers."

I have taken the Agency for the United States for this apparatus, and am now prepared to make contracts to erect it on the premises of any Gas Company. It would be manufactured in the following sizes:

No. 1,	50,000 to	100,000	cu. ft. per 24 hrs.,	3	ft. square,	5	ft. deep.
No. 2,	"	125,000	" " "	4	" " "	"	"
No. 3,	"	250,000	" " "	5	" " "	"	"
No. 4,	"	500,000	" " "	6	" " "	"	"
No. 5,	"	750,000	" " "	7	" " "	"	"
No. 6,	"	1,000,000	" " "	8	" " "	"	"
No. 7,	"	1,250,000	" " "	9	" " "	"	"
No. 8,	"	1,500,000	" " "	10	" " "	"	"
No. 9,	"	2,000,000	" " "	12	" " "	"	"
No. 10,	"	3,000,000	" " "	15	" " "	"	"

This Tar Extractor will perform its work with about one-fourth the usual back-pressure heretofore required. It is simple in construction, and can be supplied at a very reasonable price—less than any other ever before introduced. Satisfactory results will be guaranteed in every instance.

GEO. SHEPARD PAGE,

SOLE AGENT FOR THE UNITED STATES,

No. 69 Wall Street, - - - New York,

THE UNITED GAS IMPROVEMENT CO.

DREXEL BUILDING, PHILADELPHIA.

OFFICERS:

WILLIAM W. GIBBS, President.

GEORGE PHILLER, Vice-President.

SAM'L T. BODINE, Gen'l Manager.

RANDAL MORGAN, Gen'l Counsel.

EDWARD C. LEE, Sec'y and Treas.

ALEX. C. HUMPHREYS, Gen'l Supt.

WALTON CLARK, Ass't Gen'l Supt.

H. H. EDGERTON, Chem. and Eng'r.

DIRECTORS:

GEORGE PHILLER,

THOMAS DOLAN,

HENRY C. GIBSON,

WM. T. CARTER,

WILLIAM G. WARDEN,

SAM'L T. BODINE.

BUILDERS, LESSEES AND PURCHASERS OF

⇒ GAS WORKS. ⇐

Orders solicited from Large Cities, Small Towns, Mills, Institutions, from all who want more Light for Less Money.

NATIONAL GAS LIGHT AND FUEL COMPANY,

No. 218 La Salle Street, Chicago.

THE SPRINGER SYSTEM

OF

Fuel and Illuminating Water Gas Works.

REFERENCES.

People's Gas Lt. & Coke Co.. Chicago, Ill.
 Illinois Light, Heat & Power
 Co. Chicago, Ill
 Elgin National Watch Co. . Elgin, Ill.
 C. R. I. & P. R. R. Shops . Chicago, Ill.
 Decatur Gas Lt & Coke Co.. Decatur, Ill.
 Niles Gas Light Co. Niles, Mich.
 Newton Illuminating Co. . . Newton, Kansas.
 Wellington Light & Heat Co.. Wellington, Kansas.
 Chippewa Falls Gas Lt. Co.. Chippewa Falls, Wis.
 Elkhart Gas Lt & Coke Co. . Elkhart, Ind.
 Madison City Gas Light Co. Madison, Wis.
 South Bend Gas Light Co. . South Bend, Ind.
 Sheboygan National Gas Co. Sheboygan, Wis.
 Salina Gas Light Co. Salina, Kansas.
 The Rathbun Co. Deseronto, Prov. Ont.
 Jefferson City Gas Lt. Co. . Jefferson City, Mo.
 Mankato Gas Light Co. Mankato, Minn.
 Lima Gas Light Co. Lima, Ohio.

Minneapolis Gas Light and
 Coke Co. Minneapolis, Minn.
 Bellevue Water and Fuel }
 Gas Light Co. } Bellevue, Campbell
 } County, Ky.
 Bucyrus Gas Lt. & Fuel Co. Bucyrus, Ohio.
 Morris Gas Co. Morris, Ill.
 Los Angeles Gas Co. Los Angeles, Cal.
 San Diego Gas Fuel & Elec-
 tric Lt. Co. San Diego, Cal.
 Sioux Falls Gas Co. Sioux Falls, Dak.
 Dakota Gas and Fuel Co. . Grand Forks, Dak.
 St. Johns Mutual Gas Co. . St. Johns, Mich.
 Stillwater Gas Light Co. . . Stillwater, Minn.
 St. Paul Gas Light Co. St. Paul, Minn.
 Emporia Electric and Gas
 Light Co. Emporia, Kas.
 Van Wert Gas Light Co. . . Van Wert, Ohio.
 Lansing Gas Light Co. Lansing, Mich.
 San Francisco Gas Lt. Co. . San Francisco, Cal.

Shelbyville Gas Light Co. . Shelbyville, Ind.
 Great Falls Gas Light Co. . Great Falls, N. H.
 Belleville Gas Co. Belleville, Ontario
 Rochester Lt. and Fuel Co. Rochester, Minn.
 Northwestern Gas Light and
 Coke Co. Evanston, Ill.
 Lincoln Gas Light Co. Lincoln, Neb.
 Davenport Gas Light Co. . . Davenport, Iowa.
 Municipal Gas Co. Albany, N. Y.
 Alliance Gas Light Co. Alliance, Ohio.
 New Gas Light Co. Janesville, Wis.
 Chicago Gas Lt. & Coke Co., Chicago, Ill.
 Joliet Gas Co. Joliet, Ills.
 Superior Light & Fuel Co. . Superior, Wis.
 Kewanee Gas Light Co. . . Kewanee, Ill.
 Aberdeen Light & Fuel Co. . Aberdeen, So. Dak.
 Pierre Light and Fuel Co. . Pierre, So. Dak.
 *Standard Gas Light Co. . . New York City.
 *Carlinville Gas Light Co. Carlinville, Ill.

* Building.

GUARANTEED ESTIMATES of Cost of Gas Furnished on Application.

GASHOLDER TANK CONSTRUCTION, ETC.

Gas Companies and others about to erect Gasholders will find it profitable to consult W. C. Whyte, who for over 30 years has made a specialty of

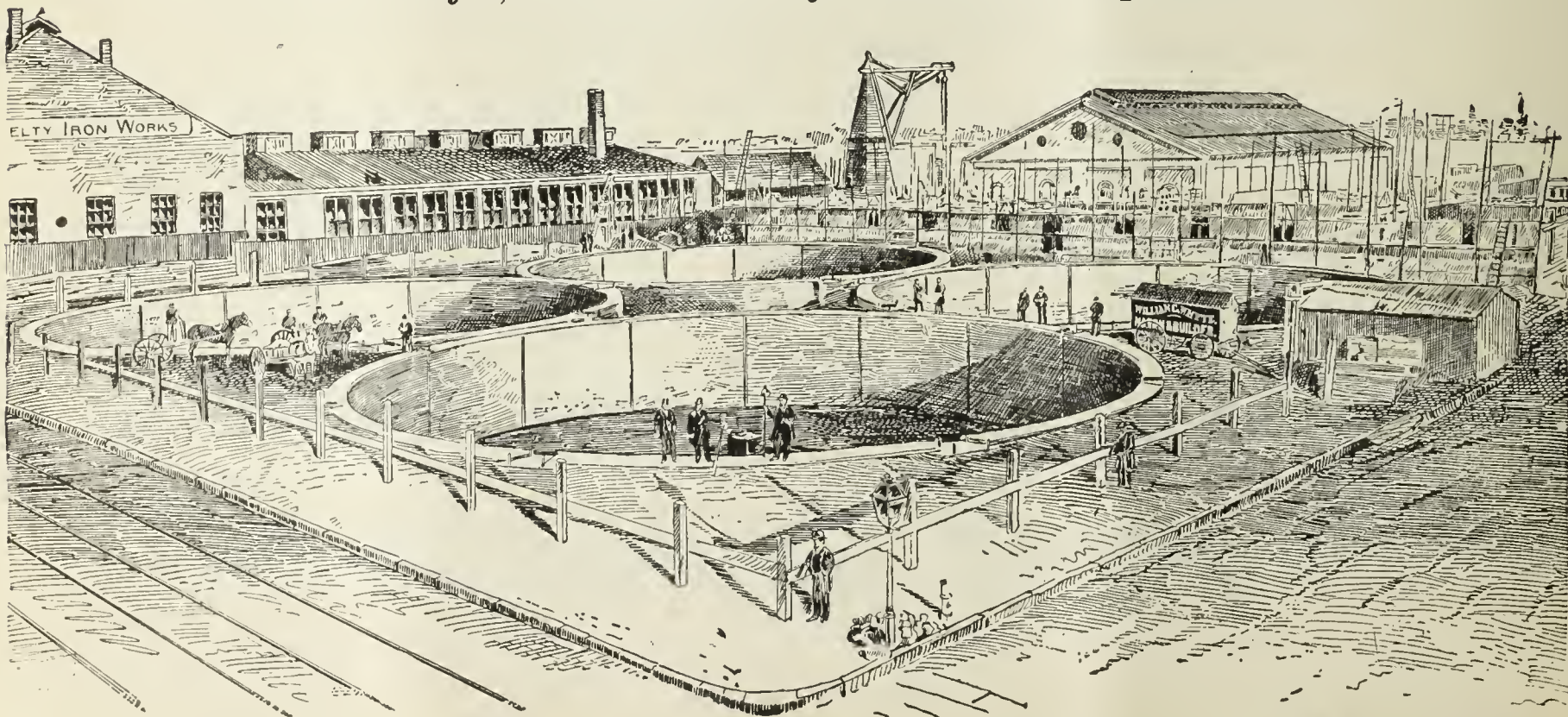

Tank Excavation and Mason Work.

Fifty Tanks now in operation show the sort of work done. Address

W. C. WHYTE, - No. 15 Cortlandt Street, N. Y. City.

CONNELLY & CO.,

SOLE MANUFACTURERS OF THEIR PATENTED SPECIALTIES.

"IRON SPONGE." Saves money, saves labor, and is the most efficient purifying agent ever offered as a substitute for lime. Now used *in every State in the Union*, and purifying daily over *thirty-five million cubic feet*. Should be used in every gas works. Its own saving will pay for it many times over.

AUTOMATIC GOVERNOR. Has been on the market but *three years*, and in that time has been introduced *more generally* than any invention ever designed for use in gas works. Over *two hundred* of them now in use. Sensitive; reliable; perfectly automatic; reduces leakage; satisfies consumers, and gives great relief to the Manager. No gas works is *complete* without one of these machines.

STEAM JET EXHAUSTER. Designed particularly for small works. Combines Exhaust Tube, Steam Governor Gas Compensator, and Bye-Pass Valves in the most compact form possible; occupies but little space; uses very little steam; operated by ordinary workmen; saves formation of carbon in retorts; increases yield 10 to 15 per cent. Specially adapted for *mixing air* with oil gas. *No works* too small to use them profitably.

Prices given on all our specialties *delivered at any point in the United States*. Correspondence solicited.

CONNELLY & CO., No. 111 Broadway, New York City.

WILBRAHAM GAS EXHAUSTER & ENGINE COMBINED.

WILBRAHAM BROS.,
PHILADELPHIA, PA.

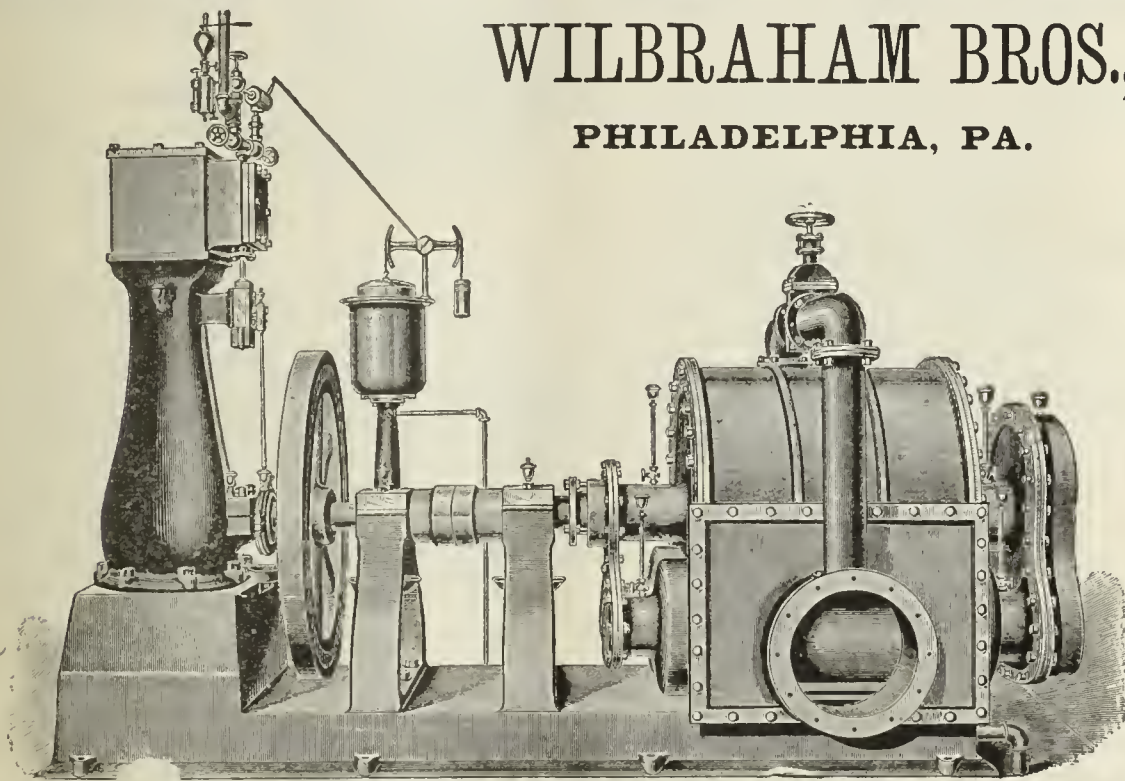

JARVIS ENGINEERING CO.,

61 Oliver St., Boston, Mass.

CONTRACTORS FOR ERECTING
COMPLETE STEAM OUTFITS FOR ELECTRIC LIGHTING STATIONS.

Steel Boilers set with Jarvis Pat. Boiler Setting

To burn **COKE SCREENINGS** for Fuel.

ARMINGTON & SIMS CO. ENGINES,

Belting direct to Dynamos, without using Shafting.

SEND FOR CIRCULARS.

REFERENCES.—Charlestown Gas & Electric Light Co., Charlestown, Mass.; Schenectady Gas & Electric Light Co., Schenectady N. Y.; Brookline Gas Co., Brookline, Mass.

Practical Electric Lighting

By A. BROMLEY HOLMES, A.M.I.C.E.

With 87 Illustrations. Third Edition. Price, \$1.00.

Electric Light Primer.

By CHARLES L. LEVEY.

A simple and comprehensive Digest of all the most important facts connected with the running of the Dynamo and Electric Lights, with Precautions for Safety, etc.

Price, 50 cents.

A. M. CALLENDER & CO., 42 Pine St., N. Y.

(Patented.) **IMPORTANT!** (Patented)

NEW SOLVENT FOR GAS PIPE DEPOSITS.

Economical and Effective.

MAAS & WALDSTEIN, 44 Trinity Place and 81 Greenwich St., N. Y.

Gasholder Tanks & Gas Works Masonry Complete.

PLANS PREPARED AND ESTIMATES FURNISHED AT SHORT NOTICE.

J. P. WHITTIER, - - 499 Wythe Av., Brooklyn, N. Y.



CHAPMAN VALVE MANUFACTURING CO.,

MANUFACTURERS OF

Valves and Gates for Gas, Ammonia, Water, Etc.

Also, Gate Fire Hydrants With and Without Independent Nozzle Valve. All Work Guaranteed.

WORKS & GEN'L OFFICE:
Indian Orchard, Mass.

TREASURER'S OFFICE:
72 Kilby & 112 Milk Sts, Boston, Mass.

LUDLOW VALVE MFG. CO.



OFFICE AND WORKS,

938 to 954 River Street and 67 to 83 Vail Av.,
TROY, N. Y.

Hydraulic Main Dip Regulators, also
Check Valves, Foot Valves, Yard
wash and Fire Hydrants.
Send for Circulars.



Valves.—Double and Single Gate, ½ in. to
48 in., outside and inside Screws. Indica-
tor, etc., for Gas, Water, Steam, and Oil.
Send for Circulars.

GEO. SHEPARD PAGE,

No. 69 Wall Street, N. Y. City.

REPRESENTING

THE BOWER GAS LAMP.

C. & W. Walker's Carbonic Acid & Tar Extracting Washer

B. DONKIN & CO.'S PAT. IMP. GAS VALVE.

Young & Beilby's Patents. Henry Aitkin's Patents.

R. P. SPICE, London, Eng. HENRY SIMON, Manchester, Eng.

MILLS' REVERSIBLE LIME TRAY,

AND

WOODWORK

Of Every Description

NEEDED BY GAS WORKS.

SEND FOR CIRCULAR AND PRICE LIST TO

BARTLETT, HAYWARD & CO.,

Pratt and Scott Streets, Baltimore, Md.

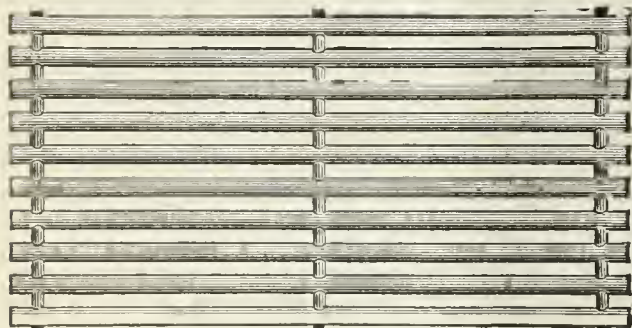

**VAN DUZEN
GAS & GASOLINE ENGINE**

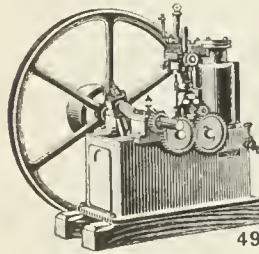

OPERATED with COAL
and OTHER MANUFAC-
TURED GASES AND
GASOLINE.

**RELIABLE AND
ECONOMICAL.**

Fully Warranted

VAN DUZEN
Gas & Gasoline Engine Co.
49 E. 2d St., Cincinnati, O.

A. MacKinnon Machine Co., Agts., 22 Warren St., N.Y.

**The Management of Small
Gas Works.**

BY C. J. R. HUMPHREYS.

Price, \$1.

Orders to be sent to **A. M. CALLENDER & CO.,**
42 PINE STREET, NEW YORK.

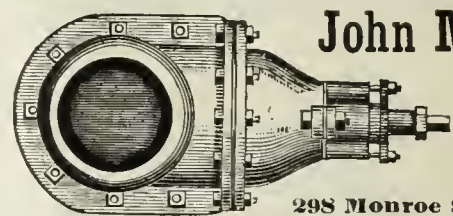

John McLean

Man'furer

**GAS
VALVES.**

298 Monroe Street, N. Y.

SPECIAL TRAYS FOR IRON SPONGE OR OXIDE OF IRON.
CHURCH'S TRAYS A SPECIALTY.

REVERSIBLE-STRONGEST-MOST DURABLE-MOST EASILY REPAIRED.

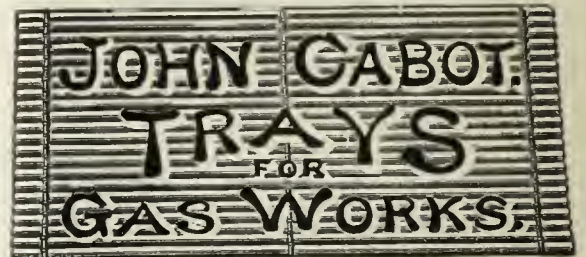

306-310 ELEVENTH AVENUE, NEW YORK.

WE ALSO MAKE THE CHEAPEST AND STRONGEST
REVERSIBLE BOLTED TRAYS IN THE MARKET.

THE CLERK GAS ENGINE CO.,

Main Office, 1012, 1014, 1016, 1018 Filbert St., Philadelphia, Pa.

WM. W. GOODWIN, Prest.

E. STEIN, Sec.

S. LEWIS JONES, Asst. Sec.

A. J. DOTY, Supt.

The utility and convenience of the Gas Engine being no longer an open question, it only remains now for intending purchasers to select the BEST. We claim for the CLERK GAS ENGINE that it is equal to any other manufactured as regards steadiness in running, simplicity, and ease of keeping in repair, and that it gives the greatest amount of power for the least money (both in first cost and expense of running) of any engine made. In support of this claim we refer to the test of the Gas Engines made under the direction of the American Institute of New York, in December, 1885, and heretofore published in these columns. These engines are especially adapted for continuous running under heavy loads, and we can refer to Engines which have run 22 hours a day for months at a time

Made in Sizes of 5 10 15 20, and 25 Horse Power. All Engines Guaranteed for One Year.

GAS STOVES.

GAS METERS.

GAS STOVES.

THE AMERICAN METER CO.,

MANUFACTURERS OF

GAS METERS, Station Meters,

METER PROVERS, PHOTOMETERS,
PRESSURE GAUGES OF ALL KINDS,



Standard 3 Diaphragm Dry Meter

AND



Standard 2 Diaphragm Dry Meter.

Apparatus for Testing the Quantity and Quality of Gases.

GAS STOVES FOR HEATING AND COOKING

Sole Agents in the United States for

Verity's Patent Gas Fires.

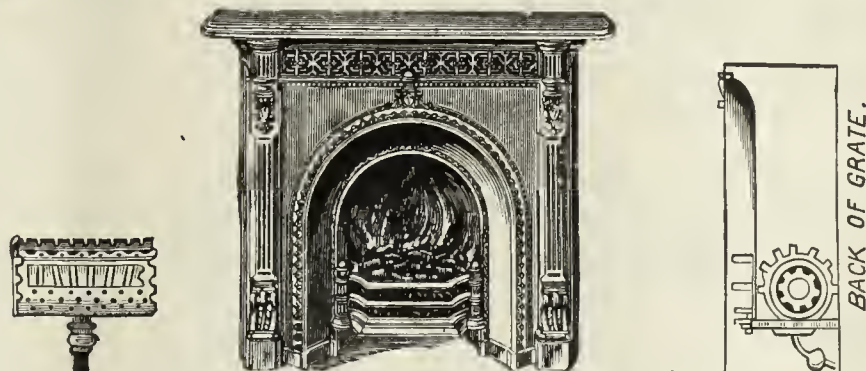

Circulars and Price Lists on Application.

MANUFACTORIES,

508 to 514 West Twenty-second St., N. Y.

Arch and Twenty-second St., Phila

Nos. 244 & 246 North Wells Street, Chicago, Ill.

AGENCIES,

No. 177 Elm Street, Cincinnati, Ohio.

No. 222 Sutter Street, San Francisco, Cal

No. 810 North Second Street, St. Louis, Mo.

STOVE SHOW ROOMS, No 242 Sixth Avenue, New York City

RETORTS AND FIRE BRICK.

J. H. CAUTIER & CO., CORNER OF GREENE AND ESSEX STREETS, JERSEY CITY, N. J.

MANUFACTURERS OF Clay Gas Retorts, Gas House Tiles, Fire Bricks, Etc. Etc. Ground Clay, Fire Brick and Fire Sand in Barrels,

J. H. GAUTIER. C. E. GREGORY. C. E. GAUTIER.

BROOKLYN Clay Retort & Fire Brick Works, (EDWARD D. WHITE & CO.) Manufacturers of Clay Retorts, Fire Brick, Gas House and other Tile. VAN DYKE, ELIZABETH, RICHARDS & PARTITION STS. Office, 88 Van Dyke St., Brooklyn, N. Y.

RETORTS AND FIRE BRICK.

LACLEDE FIRE BRICK MFG. CO., MANUFACTURERS OF Fire Brick, Gas Retorts,

AND ST. LOUIS STANDARD SEWER PIPE. Blast Furnace and Cupola Linings, every description of Fire Clay Material, Fire Clay Flue Linings, Chimney Tops Dry Milled and Crude Fire Clays, etc.

OFFICE AND DEPOT 901, 903, and 905 Pine Street, ST. LOUIS, MO.

ESTABLISHED IN 1845.

B. KREISCHER & SONS, OFFICE FOOT OF HOUSTON ST., E. R., N. Y.

Gas Retorts, TILES, FIRE BRICK. AND EVERYTHING IN THE FIRE CLAY LINE.

RETORTS AND FIRE BRICK.

MANHATTAN FIRE BRICK & ENAMELLED CLAY RETORT WORKS

ADAM WEBER. CLAY GAS RETORTS AND RETORT SETTINGS FIRE BRICKS, TILES, ETC., Office and Works, 15th Street and Avenue C., N. Y.



Works, LOCKPORT STATION, PA.

—ESTABLISHED 1864.— JAMES GARDNER, JR.,

Office, Rooms 19 & 20, Lewis Block, PITTSBURGH, PA, P. O. Box 373.

Successor to WILLIAM GARDNER & SON.

Fire Clay Goods for Gas Works.

H. A. NORTON, No. 4 CENTRAL STREET, BOSTON, MASS., Agent for the New England States.

GEO. C. HICKS, Pres. CHICAGO Retort and Fire Brick Co., MANUFACTURERS OF Fire Clay Goods of all Kinds, AND BEST QUALITY ONLY. Regenerative Furnaces & Water Gas Goods. 45th St., Clark to La Salle, Chicago.

GEROULD'S IMPROVED RETORT CEMENT. A Cement for patching retorts, putting on mouthpieces, and making up all bench-work joints. This Cement is mixed ready or use. Economic and thorough in its work. Fully warranted o stick. For recommendations and price list address C. L. GEROULD & CO., 5 & 7 Skillman St., Brooklyn, N. Y. Western Agent, H. T. GEROULD, Mendota, Ill.

Parker-Russell Mining and Mfg. Co., CITY OFFICE, Mermod-Jaccard Bldg., Rooms 307 & 308, Broadway & Locust St., St. Louis. Mo.

PROPRIETORS OF THE OAKHILL GAS RETORT & FIRE BRICK W'KS Our immense establishment is now employed almost entirely in the manufacture of

Materia's for Gas Companies We have studied and perfected three important points. Our retorts are made to stand changes of temperature, the strongest heats of the furnace, and the abrasion of feeding and emptying. We have the exclusive Agency for the West of the celebrated Kloenne-Bredel Full Depth and Semi-Recuperator Benches, And also furnish and build Our Own Styles Semi-Recuperator Furnaces for the use of Coal or Coke as fuel.

THOS. SMITH, Prest. AUGUST LAMBLA, Vice-Prest. & Supt. BALTIMORE RETORT & FIRE BRICK CO. MANUFACTORY AT LOCUST POINT, BALTIMORE, MD.

Clay Retorts, Blocks & Tiles, FIRE BRICK, FIRE CLAY, AND FIRE CEMENT.

Red and Buff Ornamental Tiles and Chimney Tops. Drain and Sewer Pipe (from 2 to 30 inches). Baker Oven Tiles 12 x 12 x 2 and 10 x 10 x 2. WALDO BROS., 88 WATER ST., BOSTON, MASS Sole Agents the New England States.

1889 DIRECTORY 1889

OF THE GAS LIGHT COMPANIES of the UNITED STATES & CANADA.

Price, \$3.00.

A. M. CALLENDER & CO., No. 42 Pine Street, N. Y. City.

HENRY MAURER & SON,

(ESTABLISHED 1856.)

EXCELSIOR FIRE BRICK & CLAY RETORT WORKS

WORKS, Perth Amboy, N. J.
OFFICE, 418 to 422 East 23d St., N. Y.

Clay Gas Retorts,
BENCH SETTINGS,
Fire Brick, Tiles, Etc.

FLEMMING'S Generator-Gas Furnace

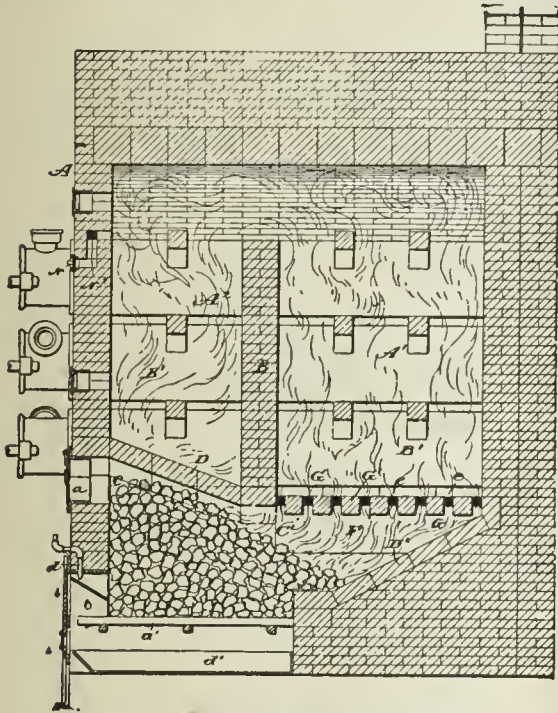

Materials furnished and Benches erected by

J. H. GAUTIER & CO., - Jersey City, N. J.

Address as above, or D. D. FLEMMING, Jersey City, N. J.

FRED. BREDEL,

CONTRACTOR FOR THE COMPLETE

Erection and Equipment of Gas Works.

SOLE PROPRIETOR OF THE

KLOENNE PATENTS

FOR NORTH AMERICA.

REGENERATIVE FURNACES.

(900 Retorts are now fired in America by the Kloenne-Bredel System.)

SELF-SEALING MOUTHPIECES.

(Over 800 Now in Use.)

Standard Condensers. Washer-Scrubbers.

TAR WASHERS FOR WATER GAS PLANTS.

(In use in the works of the Chicago Gas Lt. Co.)

GASHOLDERS.

Bredel's Automatic Gas Governor.

Refers, by permission, to Mr. Eugene Vanderpool, Newark, N. J.; Mr E. G. Cowdery, Milwaukee, Wis.; and Mr. Theo. Forstall, Chicago, Ills. For further information, address

FRED. BREDEL,

No. 208 East Seventeenth Street, N. Y. City.

<p>COMPOUND Condensing or Non-Condensing. 16 SIZES, 5 to 500 H. P. Not yet equaled by any form of Engine for HIGH FUEL DUTY AND SIMPLICITY.</p> <p>STANDARD 13 Sizes in Stock. 5 to 250 H. P. 3000 in use in all parts of the Civilized World.</p> <p>JUNIOR 6 Sizes in Stock, 5 to 50 H. P. An Automatic Engine cheaper than a Slide Valve. WELL BUILT. ECONOMICAL. RELIABLE. Over 300 Sold the First Year.</p> <p>All the above built strictly to Gauge with INTERCHANGEABLE PARTS. REPAIRS CARRIED IN STOCK. SEND FOR ILLUSTRATED CATALOGUES.</p>	<p>WESTINGHOUSE ENGINES The Westinghouse Machine Co. PITTSBURGH, PA. U.S.A.</p>	<p>SELLING DEPARTMENT IN THE UNITED STATES.</p> <table border="0"> <tr> <td>New York,</td> <td>17 Cortlandt St.</td> <td rowspan="4">} Westinghouse, Church, Kerr & Co.</td> </tr> <tr> <td>Boston,</td> <td>Hathaway Building,</td> </tr> <tr> <td>Pittsburgh,</td> <td>Westinghouse Build'g,</td> </tr> <tr> <td>Chicago,</td> <td>156, 158 Lake St.</td> </tr> <tr> <td>Philadelphia,</td> <td>608 Chestnut St. M. R. Muckle, Jr. & Co.</td> <td></td> </tr> </table> <p>ST. LOUIS, 511 NORTH FOURTH ST., Westinghouse, Church, Kerr & Co.</p> <table border="0"> <tr> <td>Salt Lake City,</td> <td>259 S. Main St.</td> <td rowspan="2">} Utah & Montana Machinery Co.</td> </tr> <tr> <td>Butte, Mont.</td> <td>2. Granite St.</td> </tr> <tr> <td>San Francisco,</td> <td>21, 23 Fremont Street,</td> <td rowspan="2">} Parke & Lacy Co.</td> </tr> <tr> <td>Portland, Or.</td> <td>33, 35 N. Front St.</td> </tr> <tr> <td>Charlotte, N. C.</td> <td>36 College St.</td> <td rowspan="2">} The D. A. Tompkins Co.</td> </tr> <tr> <td>Atlanta, Ga.</td> <td>45 S. Prior St.</td> </tr> <tr> <td>Dallas, Tex.</td> <td></td> <td rowspan="2">} Keating Imp. & Machine Co. G. E. James & Co.</td> </tr> <tr> <td>Chattanooga, Tenn.,</td> <td></td> </tr> </table>	New York,	17 Cortlandt St.	} Westinghouse, Church, Kerr & Co.	Boston,	Hathaway Building,	Pittsburgh,	Westinghouse Build'g,	Chicago,	156, 158 Lake St.	Philadelphia,	608 Chestnut St. M. R. Muckle, Jr. & Co.		Salt Lake City,	259 S. Main St.	} Utah & Montana Machinery Co.	Butte, Mont.	2. Granite St.	San Francisco,	21, 23 Fremont Street,	} Parke & Lacy Co.	Portland, Or.	33, 35 N. Front St.	Charlotte, N. C.	36 College St.	} The D. A. Tompkins Co.	Atlanta, Ga.	45 S. Prior St.	Dallas, Tex.		} Keating Imp. & Machine Co. G. E. James & Co.	Chattanooga, Tenn.,	
New York,	17 Cortlandt St.	} Westinghouse, Church, Kerr & Co.																																
Boston,	Hathaway Building,																																	
Pittsburgh,	Westinghouse Build'g,																																	
Chicago,	156, 158 Lake St.																																	
Philadelphia,	608 Chestnut St. M. R. Muckle, Jr. & Co.																																	
Salt Lake City,	259 S. Main St.	} Utah & Montana Machinery Co.																																
Butte, Mont.	2. Granite St.																																	
San Francisco,	21, 23 Fremont Street,	} Parke & Lacy Co.																																
Portland, Or.	33, 35 N. Front St.																																	
Charlotte, N. C.	36 College St.	} The D. A. Tompkins Co.																																
Atlanta, Ga.	45 S. Prior St.																																	
Dallas, Tex.		} Keating Imp. & Machine Co. G. E. James & Co.																																
Chattanooga, Tenn.,																																		

Newbigging's Handbook for Gas Engineers and Managers.

The present (the fifth) edition marks an important advance on those that have gone before. Considerable additions have been made to the text, and much of it has been re-written and otherwise improved. It extends to 524 pages, and contains 193 illustrations. Price, Cloth, \$6.00.

A. M. CALLENDER & CO., - - - - No. 42 Pine Street, N. Y. City.

GAS AND WATER PIPES.

GAS AND WATER PIPES.

ENGINEERS.

SAM'L R. SHIPLEY, Pres.
HENRY B. CHEW, Tre

JAS. P. MICHELLON, Sec.
WM. SEXTON, Supt.

P. D. WANNER, Chairman. A. H. MELLERT, Mangr. of Wks.
R. B. KINSEY, Secretary. F. A. KNOPP, Treasurer.

GLOUCESTER IRON WORKS,
GLOUCESTER CITY, N. J.



Cast Iron Gas & Water Pipes, Stop Valves, Fire Hydrants, Gasholders, &c.

Office, Rooms 61 and 63 Bullitt Building, 131 S. 4th St., Phila., Pa.

WARREN FOUNDRY AND MACHINE CO.,

Established 1856. Works at Phillipsburgh, N. J.

New York Office, 160 Broadway.

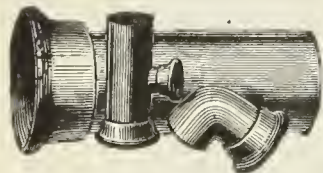

CAST IRON WATER AND GAS PIPE,

FROM TWO TO FORTY-EIGHT INCHES DIAMETER. ALSO, ALL SIZES OF

Flange Pipe for Sugar House and Mine Work. Branches, Bends, Retorts, etc., etc.

DENNIS LONG & COMPANY,

LOUISVILLE, KY.,



Manufacture Exclusively

CAST IRON GAS & WATER PIPE & SPECIAL CASTINGS
OF ALL SIZES.

King's Treatise on Coal Gas.

A standard text-book for the Engineers and Managers of Gas Works, and for all who are concerned or take an interest in the manufacture and distribution of Coal Gas, and in the utilization of the Secondary Products resulting therefrom; treating also of the Gas Engine, and of Gas Cooking and Heating Appliances.

In 3 Vols. Price per Vol., \$10. Sold either by Volume or in Sets.

A M. CALLENDER & CO., 42 Pine St., N. Y.

MELLERT FOUNDRY & MACHINE CO. Ltd.
and **READING FOUNDRY CO., Ltd.**

Reading, Pa.

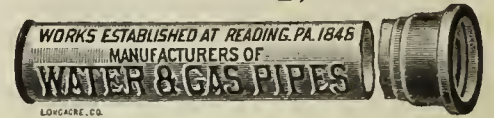

Specials—Flange Pipe, Valves and Hydrants
Lamp Posts, Retorts, etc.

General Foundry and Machine Work.

JOHN FOX, Selling Agent. 160 Broadway, N.Y.

THE OHIO PIPE COMPANY,

MANUFACTURERS OF

Cast Iron Gas & Water Pipe,

BRANCH AND SPECIAL CASTINGS.

Gas-House Bench Castings, Hydraulics, Lamp Posts, Flange Pipe
and Specials, Architectural Castings, Building Columns,
Joists, Cellar Grates, Sash Weights, etc.

GENERAL FOUNDERS AND MACHINISTS.

Columbus, Ohio.

M. J. DRUMMOND,



SPECIAL CASTINGS AND LAMP POSTS.

Office, Corbin Building, 192 Broadway, N. Y.

EMAUS PIPE FOUNDRY.

DONALDSON IRON COMPANY. EMAUS, PA.



MANUFACTURERS OF

CAST IRON PIPE AND SPECIAL CASTINGS
FOR WATER AND GAS.

JOS. R. THOMAS,

No. 42 Pine Street, N.Y. City.

CONSULTING AND CONSTRUCTING

Gas Engineer and Contractor.

PLANS, SPECIFICATIONS, AND ESTIMATES
FURNISHED.

Contracts taken for all Appliances
required at a Gas Works,

Either for New Works or Extensions to Old Plants.

WM. MOONEY

(Successor to WM. FARMER)

No. 94 Liberty St., N Y. City.

GAS ENGINEER AND CONTRACTOR FOR THE ERECTION
OF GAS WORKS, OR APPARATUS OF ANY
CAPACITY.

Plans and Specifications Furnished.

WM. GARDNER,
Gas Engineer,

Lewis Block, Room 20, Pittsburgh, Pa.

Those who intend to make alterations in existing gas plants, or who contemplate the erection of new works, will find it to their interest to open correspondence with the above. Plans made and estimates furnished.

ARTLETT, HAYWARD & CO., Baltimore, Md.

Triple Double, & Single-Lift
GASHOLDERS.

Iron Holder Tanks.

ROOF FRAMES.

Cirders.

BEAMS.

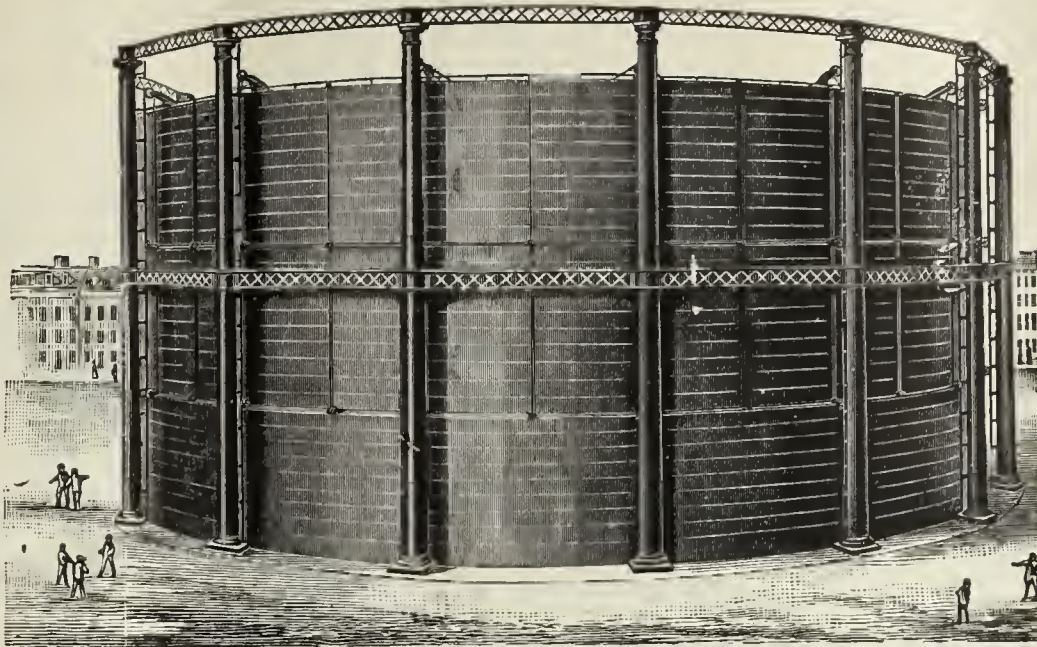

PURIFIERS.

CONDENSERS.

Scrubbers.

BENCH CASTINGS.

OIL STORAGE TANKS.

Boilers.

The Wilkinson Water Gas Process.

THIRTY-CANDLE, NON-CONDENSABLE, FIXED GAS. THE MOST SUCCESSFUL GAS PROCESS IN OPERATION.

Munich Regenerative Furnace, System Drs. Schilling & Bunte.

HAZELTON BOILERS.

Gas Works Designed and Constructed.

Pascal Iron Works. ESTABLISHED 1821. Delaware Iron Works.

MORRIS, TASKER & CO.,

INCORPORATED.

OFFICE, 224 SOUTH THIRD STREET, - - PHILADELPHIA, PA.

CONTRACTORS, BUILDERS, AND MANUFACTURERS OF

Gas, Water & Sugar Works

Bench Castings.

Condensers.

Scrubbers.

Purifiers.

Hyd. Carriages.

Iron Floors,

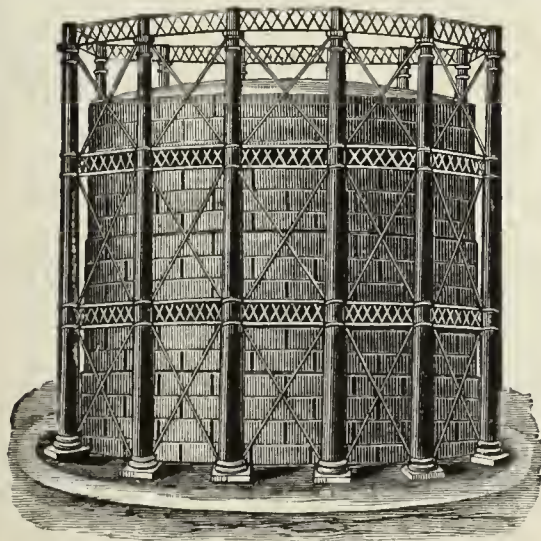

Iron Roofs.

Street Stops,

Valves, etc.

Stand-Pipes.

Water & Oil

Tanks, all Sizes.

Single, Double, and Triple-Lift Gas Holders.

SELF-SEALING RETORT LIDS. STAMPED STEEL RETORT LIDS.

Locomotive Water Columns, Filters, etc. Boiler Tubes, Wrought Iron Pipe & Fittings

Plans, Specifications and Estimates for all kinds of Machinery furnished on application.

Foundries & Works,
MILLVILLE, FLORENCE,
and CAMDEN, N. J.

R. D. WOOD & CO.,

Engineers,
Iron Founders,
and
Machinists.

400 Chestnut St., PHILADELPHIA, PA.

MANUFACTURERS OF

CAST IRON PIPE,

Gas Holders,

SINGLE, DOUBLE, AND TRIPLE LIFTS, WITH
OR WITHOUT WROUGHT IRON
OR STEEL TANKS.

PURIFIERS, CONDENSERS.

Scrubbers.

BENCH WORK.

Iron Floors and Roofs, Plate Girders.

Heavy Loam Castings.

HYDRAULIC WORK.

Lamp Posts, Valves, Etc.

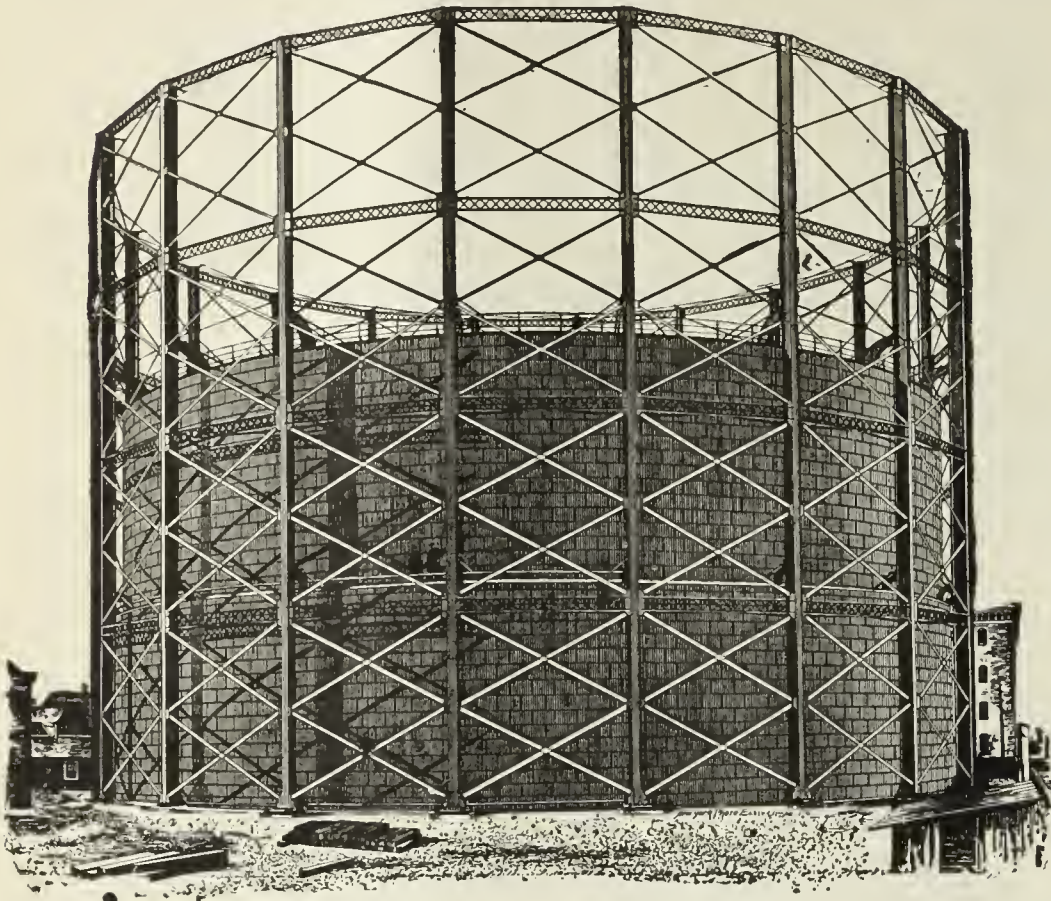

SMITH & SAYRE MFG. COMPANY,

G. G. PORTER, Prest.

245 Broadway, N. Y.

CHAS. W. ISBELL, Sec'y.

Machinery & Apparatus for Gas Works

Drawings, Plans, and Estimates Furnished for the Improvement, Extension, or Alteration of Gas Works, or for the Construction of New Works.

Mackenzie's Patent Rotary and Steam Jet Gas Exhausters, Governors, Compensators, Condensers, Washers, Scrubbers. Isbell's Patent Automatic Street Pressure Governor, Gas and Water Valves, Hydraulic Main Dip Regulator, Bench Castings, etc. Purifying Boxes and "Standard" Scrubbers, Isbell's Patent Self-Sealing Retort Doors.

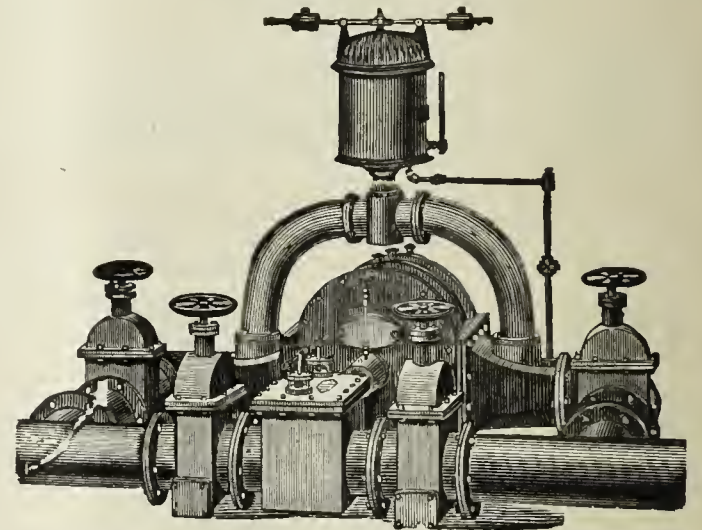

THE BRENNER SELF-SEALING RETORT DOOR.

Simple, Strong, and Durable.

CLOSES ABSOLUTELY TIGHT & IS LOCKED BY A CAM LEVER. ALL NECESSARY ADJUSTMENT FOR WEAR PROVIDED.

BUILT BY

SMITH & SAYRE MFG. CO.,

No. 245 Broadway, - - - New York City.

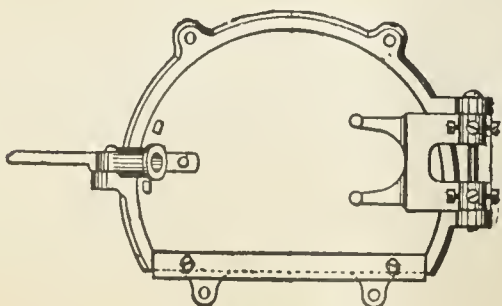

Brenner Self-Sealing Retort Door.

WILLIAM B. LUNDIE, Superintendent of the 42d Street Station of the Consolidated Gas Company, of New York, writes, under date of Jan. 4, 1889:

"We have 320 Brenner Self-Sealing Lids in use at this Station, built by the Smith & Sayre Mfg. Co. They require very little attention, and are the best of the kind that I have seen, giving entire satisfaction."

GAS WORKS APPARATUS AND CONSTRUCTION.

GAS WORKS APPARATUS AND CONSTRUCTION.

JAMES R. FLOYD & SONS,

(SUCCESSORS TO HERRING & FLOYD)

Oregon Iron Works,

W. 20th & 21st. Sts., bet. 10th & 11th Avs.,

NEW YORK CITY.

Engineers and Contractors

FOR THE

CONSTRUCTION OF GAS WORKS.

MANUFACTURERS OF

All Kinds of Castings and General Ironwork

FOR

GAS APPARATUS.

Bench Castings, Regenerative and Half Regenerative Furnace Castings.

Condensers, Scrubbers, Purifiers, Street Drips and Connections,

Valves,

Hydraulic Hoisting Purifier Carriage, Self-Sealing Retort Lids, Improved Valve Stand and Indicator,

Seller's Cement.

Plans, Specifications, and Estimates furnished for Construction of New or Alteration of Old Works.

CONTINENTAL IRON WORKS.

THOS. F. ROWLAND, Prest.

WARREN E. HILL and CHAS. H. CORBETT, V-Prests.

THOS. F. ROWLAND, JR., Sec. & Tr

P. O. Station G., BROOKLYN, N. Y.

ENGINEERS AND MANUFACTURERS OF

Gas Holders

CONDENSERS, SCRUBBERS, VALVES,

PURIFIERS, SELF-SEALING RETORT LIDS

Hydraulic Mains,

And all other articles connected with the manufacture and distribution of Gas.

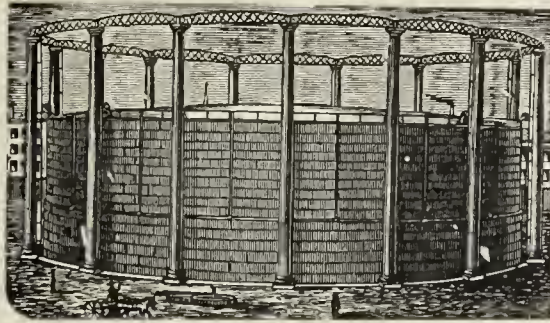

H. RANSHAW, Prest. & Mangr.

WM. STACEY, Vice-Prest.

T. H. BIRCH, Asst. Mangr.

R. J. TARVIN, Sec. & Treas.

STACEY MFG. CO.,

MANUFACTURERS OF

Single and Telescopic Gasholders,

IRON ROOFS, BRIDGES, LAMP POSTS,

Water and Oil Tanks, Coal Elevator Cars, COKE CRUSHERS, BENCH CASTINGS,

And all kinds of Wrought and Cast Iron Work used in the erection of Coal and Oil Gas Works Rolling Mill Machinery and Heavy Castings a Specialty.

Foundry:

33, 35, 37 & 39 Mill Street.

Wrought Iron Works:

16, 18, 20, 22, 24 & 26 Ramsey Street:

Cincinnati, Ohio.

Bouton Foundry Co.,

FOUNDERS AND MACHINISTS,

CHICAGO, ILL.

Gas Works Apparatus,

PURIFIERS, CONDENSERS,

Bench Work

SPECIALS, LAMP POSTS,

SCRUBBERS,

Iron Roofs and Floors.

Plans and Estimates furnished for new works or extensions of old works.

1842. **DEILY & FOWLER,** 1889.

Laurel Iron Works.

Address, No. 39 Laurel Street, Philadelphia, Pa.

BUILDERS OF

GASHOLDERS,

Single and Telescopic.

Holders Built 1884 to 1888, Inclusive:

- | | | | | |
|----------------------------|-----------------------------|---------------------------|--------------------------|------------------------|
| Newport, R. I. | Long Island City, N. Y. | Port Chester, N. Y. | Malden, Mass. | West Chester, Pa. (2d) |
| Portland, Oregon. | Macon, Ga. | New Rochelle, N. Y. | Paducah, Ky. | Lancaster, Pa. (3d) |
| Allegheny, Pa. (2d.) | York, Pa. | Salem, N. J. (3d) | Norwich, Conn. | Fac-ny, Pa. (two) |
| Atlanta, Ga. (2d.) | Chester, Pa. | Omaha, Neb. (2d) | Seattle, W. T. | Mount Vernon, N. Y. |
| N.Y. City (Central Gas Co) | Hazleton, Pa. (2d.) | Lynn, Mass. (2d) | San Diego, Cal. | Binghamton, N. Y. |
| Lynchburg, Va. (2d.) | Staten Island, N. Y. | Little Rock, Ark. | Northern Gas Lt. Co., of | Concord, N. H. |
| Saylesville, R. I. | Saugerties, N. Y. | Irvington, N. Y. | New York, N. Y. | Dover, Del. (2d) |
| Rondout, N. Y. | Clinton, Mass. (Lan. Mills) | South Boston, Mass. | Westerly, R. I. | Calais, Me. |
| Atlantic City, N. J. | Chattanooga, Tenn. | Rye, N. Y. (2) | Willimantic, Conn | New Loudon, Conn. (2d) |
| Augusta, Ga. | Galveston, Texas. (3d.) | Woodstock, Ont. | Montclair, N. J. | West Chester, N. Y. |
| Waltham, Mass. (2) | Omaha, Neb. | Malden, Mass. | Attleboro, Mass. | Bay Shore, L. I. |
| Mahanoy City, Pa. | Fort Plain, N. Y. | Staten Island, N. Y. (2d) | Santa Cruz, Cal. | Washington, D. C. |
| New Castle, Pa. | Brunswick, Ga. | Woodstock, Ont. | Erie, Pa. (2d) | |

WM. HENRY WHITE,

No. 32 Pine Street, - - - New York City.

ENGINEER AND CONTRACTOR FOR THE

Erection and Extension of Gas, Water, and Electric Light Works.

SOLE REPRESENTATIVE OF THE

McILHENNY REGENERATOR FURNACE PATENTS

And the Martin Water Gas Process.

Edison Incandescent and American Arc Electric Light Plants Installed.

Correspondence with Gas Companies contemplating extending or improving their Plants respectfully invited.

Plans and Estimates Furnished.

GAS COALS.

CANNEL COALS.

GAS ENRICHERS.

JAMES D. PERKINS. **PERKINS & CO.,** F. SEAVERN.
228 & 229 Produce Exchange, New York.

Cable Address, "PERKINS, NEW YORK."

Post Office Box 3695, New York.

GENERAL SALES AGENTS FOR

The Youghiogeny River Coal Company's

OCEAN MINE YOUGHIOGHENY GAS COAL.

HON. W. L. SCOTT, Prest.

M. H. TAYLOR, Vice-Prest.

This Colliery is located at SCOTT HAVEN, PA., in the center of the Youghiogeny Gas Coal District, and produces the ONLY RELIABLE YOUGHIOGHENY COAL for gas purposes. (See Map on p. 87 of this JOURNAL, Feb. 16, '85.)

POINTS OF SHIPMENT,

Locust Point, BALTIMORE.

Pier No. 62, PHILADELPHIA.

Also, SOLE AGENTS for the

BRECKENRIDGE CANNEL,

OF KENTUCKY.

Within the past two years we have delivered this Cannel to over ONE HUNDRED COMPANIES IN THIRTY-THREE DIFFERENT STATES, and it is now in use in some of the large Gas Works

On the Continent and in South America,

where it successfully competes with the Australian Shale. It is the ONLY AMERICAN GAS CANNEL of sufficiently high grade to warrant EXPORTATION TO EUROPE AND SOUTH AMERICA, and it is the only economical substitute for OIL OR NAPHTHA. ONE GROSS TON will produce

10,000 Cubic Feet of 75 Candle Gas,	} equal to {	750,000 Candle Feet of Gas, and 26 Bushels
or 12,500 " " 60 " "		of merchantable Coke weighing 900 Pounds
or 15,000 " " 50 " "		

This is the ONLY GAS CANNEL that will produce a REALLY MERCHANTABLE COKE. It can be delivered in parcels of one carload or more to any point in the United States or Canada. Cargo shipments of any size required can be made from NEW YORK, PHILADELPHIA, BALTIMORE, or NEWPORT NEWS. Samples will be sent and particulars of price, etc., forwarded upon application to above address.

JAMES & WILLIAM WOOD,

Gas and Cannel Coal Contractors,

No. 40 St. Enoch Sq., Glasgow. No. 2 Talbot Court, London.

Proprietors of the BATHVILLE COLLIERIES (which produce the celebrated BOGHEAD CANNEL), Shields, Shieldmuir, Drumpeller, and other Collieries. This Firm offer

STANDARD CANNELS,

Unequaled as Gas Enrichers.

Also, WEST FAIRMONT GAS COAL, of W. Va.

Analyses, prices, and all further information furnished on application to

Agency for U. S., Room 93, Nos. 2 & 4 Stone St., N.Y. City.

The Standard Oil Company,

REFINERS OF

NAPHTHA AND GASOLINES.

ALSO MANUFACTURERS OF

A Special Grade of Naptha for Gas Companies

FOR ENRICHING COAL GAS.

Correspondence solicited.

No. 43 Euclid Avenue, Cleveland, Ohio.

To Gas Companies.

We make to order CAP BURNERS to burn any amount under a stated pressure. Send for samples.

Also, SERVICE CLEANERS, DRIP PUMPS, and STREET MAIN PROVING APPARATUS.

C. A. GEFROER,

248 N 8th Street, Phila., Pa.

COKE CRUSHERS.

Newburgh Orrel Coal and Coke Co.

MINERS AND SHIPPERS OF

STEAM, SMITHING, AND GAS COALS,
Foundry and Crushed Coke.

Home Office, 33 S. Gay Street, Baltimore, Md.

J. HARRY LEE, President.

Shipping Wharves, Locust Point, Baltimore.

The Despard Gas Coal Co.,

MINERS AND SHIPPERS OF

DESPARD GAS COAL,

AND MANUFACTURERS OF

COKE.

MINES, Clarksburg, Harrison Co., W. Va.

WHARVES, Locust Point, Baltimore, Md.

OFFICE, 225 E. German St., " "

ROUSSEL & HICKS, } AGENTS. } BANGS & HORTON,
71 Broadway, N. Y. } 60 Congress St., Boston.

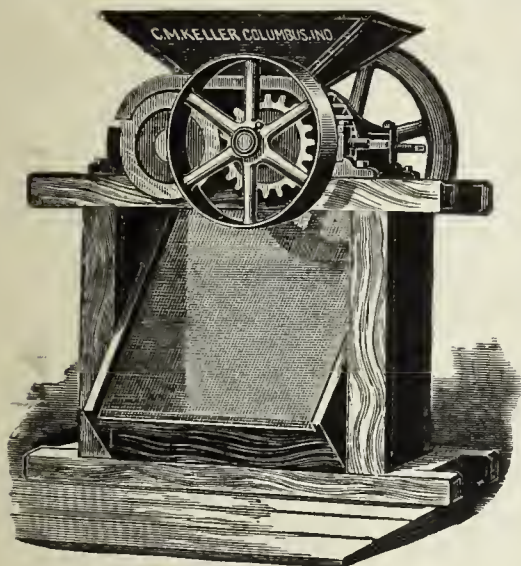

Keller's Adjustable Coke Crusher.

SIMPLE, STRONG, AND DURABLE.

C. M. Keller, Sec. & Supt. Gas Lt. & Coke Co. Columbus, Ind.

Correspondence Solicited.

King's Treatise on Coal Gas.

The most complete work on Coal Gas ever published.

Three Vols. Bound, \$30.

BOOKS.

DISTILLATION OF COAL TAR AND
AMMONIACAL LIQUOR.

By GEORGE LUNGE. Price \$12.50.

A TREATISE ON THE COMPARATIVE
COMMERCIAL VALUES OF GAS
COALS AND CANNELS.

By DAVID A. GRAHAM. 8vo., Cloth. Price \$3.

Orders for these books may be sent to this office.

A. M. CALLENDER & CO.,

42 PINE ST., N. Y. CITY

GAS COALS.

GAS COALS.

**THE
PENN GAS COAL CO.**

OFFER THEIR

Coal, Carefully Screened & Prepared for Gas Purposes.

Their Property is located in the Youghiogeny Coal Basin, near Irwin and Penn Stations on the Pennsylvania Railroad, and on the Youghiogeny River.

Principal Office:

209 SOUTH THIRD STREET, PHILA., PA.

Points of Shipment:

Pennsylvania Railroad Piers; Greenwich Wharves, Delaware River; Pier No. 1 (Lower Side), South Amboy, N. J.

Chesapeake & Ohio Railway Coal Agency,

FOR THE SALE OF THE

**Superior Kanawha Gas Coals, Cannelton Cannel,
Also, SPLINT AND STEAM COALS.**

From the Kanawha and New River Regions, on the line of the Chesapeake & Ohio R'way.

C. B. ORCUTT, General Agent, - - No. 1 Broadway (Room 217) New York City.

FRANCIS H. JACKSON, Prest. EDMUND H. MCCULLOUGH, V.-Prest. CHAS. F. GODSHALL, Treas. H. C. ADAMS, Sec.

THE WESTMORELAND COAL CO.

Chartered 1854.

Mines situated on the Pennsylvania and the Baltimore and Ohio Railroads, in Westmoreland County, Penn.

POINTS OF SHIPMENT:

PHILADELPHIA, BALTIMORE, SOUTH AMBOY, N. J.,
WATKINS (SENECA LAKE), N. Y.

Since the commencement of operations by this Company its well-known Coal has been largely used by the Gas Companies of New England and the Middle States, and its character is established as having no superior in gas-giving qualities, and in freedom from sulphur and other impurities.

Principal Office, 224 South 3d St., Phila., Pa.

**The American Gas Engineer
and Superintendent's Handbook.**

By WILLIAM MOONEY.

Consisting of Rules, Reference Tables, and Original Matter
Pertaining to the Manufacture, Manipulation, and
Distribution of Illuminating Gas.

350 Pages, Full Gilt Morocco.

\$3.00.

A. M. CALLENDER & CO., 42 Pine St., N. Y.

GAS METERS.

GAS METERS.

GAS METERS.

ESTABLISHED 1859.

JOHN J. GRIFFIN & CO.,

Nos. 1513, 1515, 1517, & 1519 Race St., PHILADELPHIA.
 No. 52 Dey Street, NEW YORK. No. 75 North Clinton Street, CHICAGO.

Manufacturers of Meters for Measuring Gas

IN ANY VOLUME.

EXPERIMENTAL APPARATUS FOR QUANTITATIVE AND QUALITATIVE ANALYSIS.

Provers, Gauges, Registers, Etc.

Careful and Prompt Attention paid to the Repairing of all kinds of Meters and Apparatus.

Estimates Cheerfully Furnished.

Dry Gas Meters.

With 40 years' experience and the best facilities for manufacturing, is enabled to furnish reliable work and answer orders promptly.

NATHANIEL TUFTS,*No. 153 Franklin Street, Boston, Mass.,*

MANUFACTURER OF

DRY GAS METERS.

Station Meters of any Capacity.

Test and Experimental Meters, Pressure Registers, Pressure Gauges, Pressure and Vacuum Gauges.

METER PROVERS, PHOTOMETERS, STREET LANTERNS, ETC., ETC.

Patent Cluster Lanterns for Street Illumination.

HAROLD J. BELL.

BELL & JONES,

S. LEWIS JONES.

No. 12 North Ninth Street, Philadelphia, Pa. Works at Royersford, Pa.

MANUFACTURERS OF

GAS METERS, STATION AND EXPERIMENTAL METERS,**Meter Provers, Pressure Gauges, and All Other Gas Appliances in Our Line.**

WE REPAIR ALL KINDS AND MAKES OF METERS, AND THE WORK GUARANTEED.

High Pressure Meters for Natural Gas, in Iron Cases, guaranteed to stand 300 lbs. Pressure.
 Gas Cooking and Heating Stoves, Hot Plates, Cake Griddles, Waffle Bakers, Boiling Stoves, Laundry and Tailors' Iron Heaters. Hotel and Cafe Ranges a Specialty.

Correspondence Solicited.

Estimates Furnished.

CHARLES E. DICKEY.

JAMES B. SMALLWOOD.

CHARLES H. DICKEY.

THE MARYLAND METER AND MANUFACTURING CO.

Established 1866.

BALTIMORE, North & Saratoga Sts.

CHICAGO, 197 Michigan Street.

NEW YORK, 766 Broadway.

BOSTON, 4 Central Street.

ST. LOUIS, 1115 Olive Street.

SAN FRANCISCO, 330 Pine Street.

CONSUMERS' & STATION METERS, PRESSURE GAUGES, Etc., Etc.**"Success" and "Perfect" Gas Stoves.**

GAS METERS.

GAS METERS.

GAS METERS.

GEO. J. MCGOURKEY, Prest.

WM. H. MCFADDEN, Vice-Prest. (Phila.)

WM. N. MILSTED, Gen. Supt. and Treas. (New York).

WM. H. DOWN, Sec.

THE AMERICAN METER CO.

WET AND DRY GAS METERS.

PRESSURE REGISTERS.

METER PROVERS.

STATION METERS.

PRESSURE & VACUUM REGISTERS.

PORTABLE TEST METERS.

EXHAUSTER GOVERNORS.

PRESSURE & VACUUM GAUGES.

EXPERIMENTAL METERS.

DRY CENTER VALVES.

CRESSON GAS REGULATORS.

AMMONIA TEST METERS.

GOVERNORS FOR GAS WORKS.

MARSLAND WATER METERS.

BAR & JET PHOTOMETERS.

Manufactories:

512 West 22d St., N. Y.

Arch & 22d Sts., Phila.

GAS STOVES.

SUGG'S "STANDARD" ARGAND BURNERS,

SUGG'S ILLUMINATING POWER METER,

Wet Meters, with Lizar's "Invariable Measuring" Drum.

Agencies:

177 Elm Street, Cincinnati.

244 & 246 N. Wells Street, Chicago.

510 North Second Street, St. Louis.

222 Sutter Street, San Francisco.

HELME & McILHENNY,

(Established 1848.)

GAS METER MANUFACTURERS,

Nos. 1339 to 1349 Cherry Street, Philadelphia, Pa.,

WET AND DRY GAS METERS, STATION METERS, EXPERIMENTAL METERS, METER PROVERS,

Center Seals, Pressure Registers, Governors, Indicators, Photometers, and all other kinds of Apparatus for use in Gas Works.

FOULIS' PATENT STATION AND DISTRICT GOVERNORS.

REPAIRING DEPARTMENT.—We employ a special force of skilled workmen repairing meters of all makers.

WM WALLACE GOODWIN, Prest. and Treas.

WM. H. MERRICK, Vice-Prest.

S. L. JONES, Sec.

S. V. MERRICK, Supt.

THE GOODWIN GAS STOVE AND METER CO.,

Successors to W. W. GOODWIN & CO.

1012, 1014 and 1016 Filbert St., Phila., Pa.

142 Chambers St., New York City.

76 Dearborn, St., Chicago, Ills

WALDO BROTHERS, Agents, 88 Water Streets, Boston, Mass.

MANUFACTURERS OF

DRY AND WET GAS METERS,

Station Meters (square, cylindrical, or in staves), Glazed Meters, King's and Sugg's Experimental Meters, Lamp Post Meters, etc., etc. Meter

Provers (sizes 2, 5, and 10 feet), Pressure Gauges of all kinds, Pressure Registers, Pressure and Vacuum Registers, Pressure Indicators

(sizes 4, 6, and 9 inch), King's Pressure and Vacuum Gauges, Dry and Wet Center Seals, Dry and Wet Governors, Exhauster

Governors, Photometers of all descriptions. Letheby's Sulphur and Ammonia Test Apparatus complete. Also, Testing

and Chemical Apparatus of all kinds, and of the most perfect description, for all purposes relating to Gas.

Manufacturers of the "SUN DIAL" GAS STOVES, for Cooking and Heating.

Goodwin's Improved Lowe's Jet Photometer.

Agents for Bray's Patent Gas Burners and Lanterns.

Special attention to Repairs of Meters and all Apparatus connected with the business. All work guaranteed first-class in every particular. Orders filled promptly.

G. B. EDWARDS, Manager, New York.

S. S. STRATTON, Manager, Chicago.

D. McDONALD & CO.,

GAS METER MANUFACTURERS.

(Established 1854.)

51 Lancaster St., Albany, N. Y.

34 & 36 West Monroe St., Chicago, Ill.

STATION METERS, EXPERIMENTAL METERS, METER PROVERS, PRESSURE & VACUUM REGISTERS, PRESSURE GAUGES, ETC

Also STAR GAS STOVES, RANGES, and HEATING STOVES.

We use only the very best materials, and employ the most skilled labor, and by our long experience (32 years) and personal supervision of every detail, we feel justified in assuring the public that our goods will give perfect satisfaction. Every Meter emanating from our establishment will bear the State Inspector's BADGE, and will be fully warranted by us. Our Annual and Calendar will be sent to Gas Companies upon application.

GAS STOVES.

GAS STOVES.

GAS STOVES.

THE GOODWIN GAS STOVE AND METER CO.,

1012-18 Filbert St., Phila., 142 Chambers St., N. Y., 76 Dearborn St., Chicago.

Agents, WALDO BROTHERS, 88 Water Street, Boston.

WM. W. GOODWIN, Pres. and Treas.
W. H. MERRICK, Vice-Pres.
S. LEWIS JONES, Sec.

SAMUEL V. MERRICK, Supt.
G. B. EDWARDS, Mang'r, N. Y.
S. S. STRATTON, Mang'r, Chicago.

SOLE MANUFACTURERS OF THE

"SUN DIAL" GAS STOVES,

The Most Economical, Efficient, and Durable Gas Stove Made.

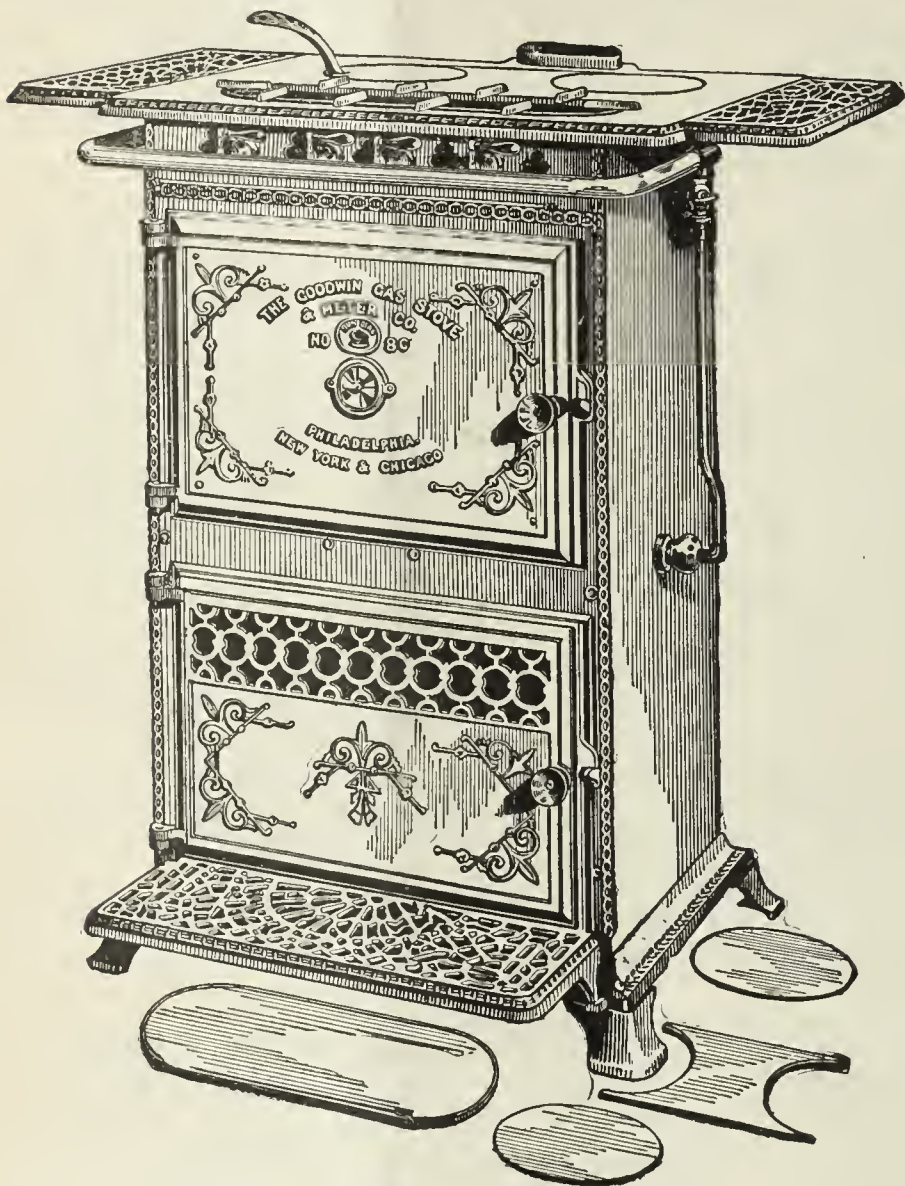

GAS COOKING STOVE, No. 8 C.

SIZE.

Stove.	Oven.	Roaster.	Top.	Length over Extension Shelves,
37 in. high. 20 in. wide.	12 in. high. 17½ in. wide. 12 in. deep.	12 in. high. 18 in. wide. 13 in. deep.	24 in. long. 21 in. wide.	38 in.

This Stove has four burners on top, and double oven burner. Consumption of gas with all burners in use, 42 feet per hour, at 1 inch pressure. The top is made in sections, so that a greater variety of cooking utensils may be used. By lifting out the covers and crosspieces and putting in a suitable forked ring, which is sent with each stove, a wash boiler or other large utensil may be set over two burners. Our No. 87 GRIDDLE also fits in the same position. The roasting oven is provided with a cast-iron door.

All Fittings are Nickel-Plated.

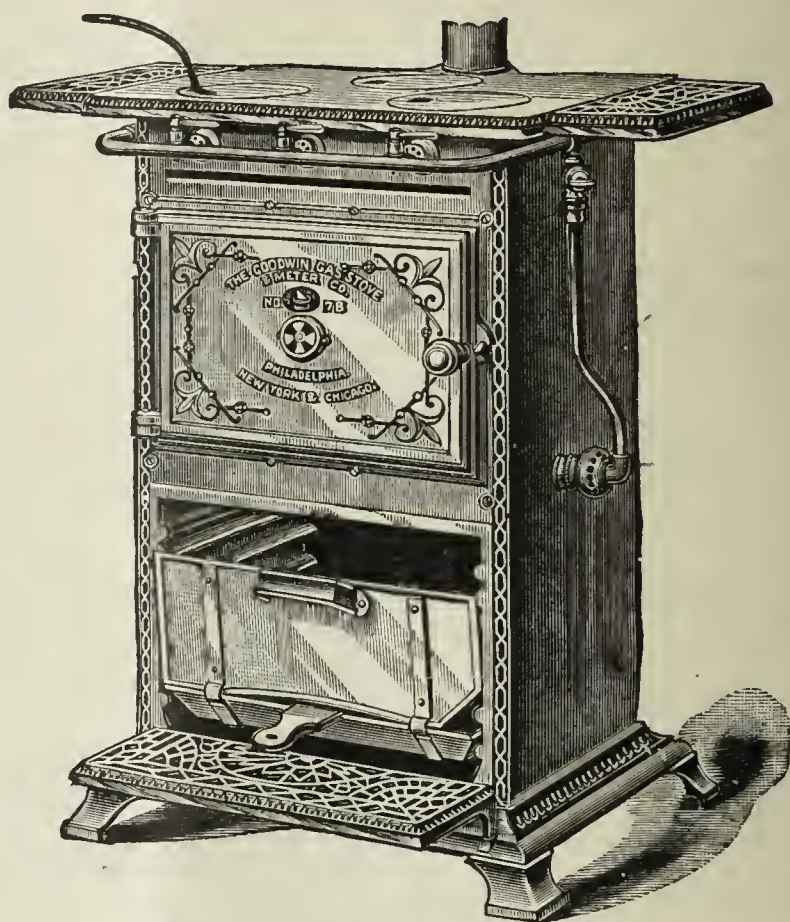

GAS COOKING STOVE, No. 7 B.

SIZE.

Stove.	Oven.	Roaster.	Top.	Length over Extension Shelves,
31 in. high. 17 in. wide.	9½ in. high. 14½ in. wide. 12 in. deep.	10 in. high. 15 in. wide. 13 in. deep.	21 in. long. 16 in. wide.	32 in.

This Stove has three boiling burners in the Top or Hot Plate, and one single oven burner.

This cut represents our New Style Cooking Stove. As will be seen, it has an ornamented cast-iron Base and Front, and extension shelves. The Oven Burner, which is atmospheric (unless otherwise ordered), is of an entirely new and improved pattern (patent). The ovens are of greater capacity than those of the old style. The Top, in conjunction with the Outlet Pipe, is designed to carry off all the products of combustion, if desired, but they are also supplied with a loose ring which converts it into an ordinary open top stove.

The consumption of this Stove is 35 cubic feet per hour at 1 inch pressure, with all Burners in use.

All Fittings are Nickel-Plated.

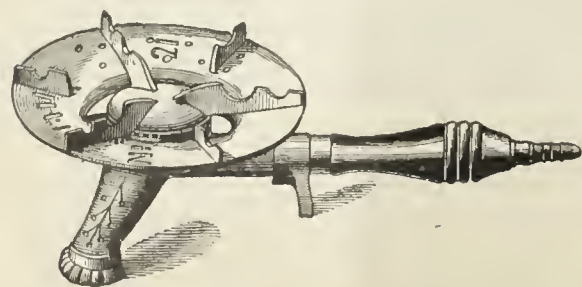

"RADIANT" BOILING STOVE, WITH REGENERATIVE BURNER.

Size, 6½ inches diameter, 8 inches high. Consumption, 6 feet per hour at 1 in. pressure.

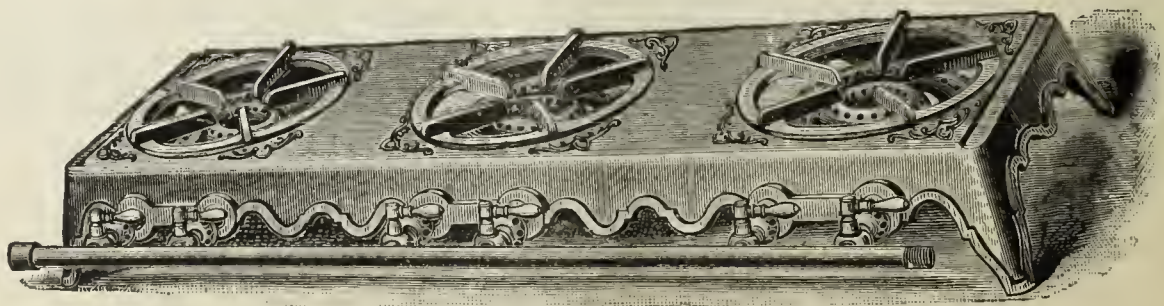

HOT PLATE, No. 111.

Size, 36 in. long, 12 in. wide, with three double burners, 6 taps. Consumption, with all burners in use, 36 cubic feet per hour, with 1 in. pressure. ¼ in. supply pipe should be used where the pressure is 1 in. or over.

THE AMERICAN

GAS LIGHT JOURNAL

REDMAN & KENNY, N. Y.

PUBLISHING OFFICE No. 42 PINE STREET

DEVOTED TO THE INTERESTS OF ILLUMINATION, VENTILATION, WATER SUPPLY AND DISTRIBUTION, & GENERAL SCIENCE.

VOLUME LII.—No. 12.
Whole No. 772.

NEW YORK, MONDAY, MARCH 24, 1890.

{ \$3 PER ANNUM,
IN ADVANCE. }

A. M. CALLENDER & CO., Proprietors. C. E. SANDERSON, Manager.
JOS. R. THOMAS, C. E., Editor. T. J. CUNNINGHAM, Asst. Editor.

ENTERED AT THE POST OFFICE AT NEW YORK, N. Y.
AS SECOND CLASS MATTER.

Published on each Monday of the year, at No. 42 Pine Street, N. Y.

Terms of Subscription, Including Postage.—For the United States and Canada, \$3 per annum. European countries, \$4.50 (19 shillings—22½ francs). All payments to be made in advance. Single copies, 10 cents.

Remittances should be made either by post-office order, registered letter, or bank draft on New York, payable to the order of A. M. Callender & Co.

Collections are invariably made directly from this office, for subscriptions, advertisements, etc. We have agents to solicit the same, but they are not authorized to receipt for money.

Correspondence.—Wishing to make this JOURNAL a gazette of intelligent discussion to those of our readers who may wish to gain or give information on the subjects to which its columns are devoted, correspondence is solicited for publication from all who make the study of those subjects a pleasure or a profession.

The American News Company, Nos. 39 and 41 Chambers street, New York, are agents for this JOURNAL. Newsdealers will send orders to them.

Books.—We will forward by express, at publisher's lowest rates, any book—scientific or otherwise—to any address in the United States or Canada. No books will be sent C. O. D.

CONTENTS.

An Asterisk (*) denotes an illustrated article.

EDITORIALS—

Briefly Told..... 389

The Meeting at Toledo—Telegraphic Editorial Correspondence—A Weekly Edition of the Electrical Engineer—Mr. Greenough's Argument against the Bowers Bill.

President Peaty's Views on the Status of English Lighting Methods 390

Twentieth Annual Meeting, New England Association of Gas Engineers—Official Report, Revised by the Secretary—Concluded from page 362..... 391

Report of Committee on President's Address—A Point or Two in regard to Illuminants during Condensation and Purification, by Geo. F. Goodno—Discussion—A Chapter of Don'ts, by W. H. Snow—Discussion—The World's Fair—Badges—Question-Box: "What is the effect on meters of the use of crude oil as an enricher?"—"How many days is it best to allow for the payment of gas bills?"—"What dissatisfaction, if any, is caused among regular customers by making a reduction to users of gas stoves?"—"What is the best material and manner of repairing leaks temporarily in holders?"—Votes of Thanks—In Memoriam, Oliver E. Cushing.

*The Meyer Valve Indicator..... 396

The Manufacture of Oxygen for Industrial Use..... 396

Fire Danger from Outside Electric Currents..... 397

Thoughts on Electric Units..... 398

ITEMS OF INTEREST FROM VARIOUS LOCALITIES..... 399

Hints from Freeport, Ills.—To Take on Electric Lighting, Frostburg, Md.—Cheaper Gas for Stoughton, Mass.—The Huntington (Pa.) Company's Electric Annex—In Charge at Westfield, Mass.—Chicago Gas Trust Dividend—Destroyed by Fire—In Charge at Elgin—In Charge at Rockford—Opposition at Los Angeles, Cal.—Fuel Gas, Louisville, Ky.—Personal—Charlton Amends his Complaint—In a Police Court—The Athens (Ga.) Company—The Failure at Greenville, O.—Opposition at Salt Lake City—Quotations for Cast Iron Pipe—Cicero, Ills., to have Gas—New Gas Company—And Many Other Items.

Hot Air Engine..... 401

The Quality of London Gas..... 401

The Market for Gas Securities..... 402

BRIEFLY TOLD.

THE MEETING AT TOLEDO.—"Toledo, O., March 19, 1890: Dear JOURNAL—Writing hurriedly at this hour, which marks the conclusion of the first days' business session of the Sixth Annual Meeting of the (I had almost written Baby Association, but fortunately remembered in time that Texas and the Southwest held the junior honors) lusty Ohio Association, I may say that it seems scarcely possible that a twelvemonth has been added to history since the last gathering, at Mansfield. Time has dealt kindly with its membership, in that the roll of a year ago remains intact, although the grim reaper has been exceptionally busy in the ranks of other Associations. You may depend upon it, however, that the death strokes which afflicted them have also awakened strongly in the breast of the Ohio Association that sympathy which kinship of the truest sort alone can call out. The cutting off of such men as King, Forstall and Cushing must be felt by all; and strongly, too. Indeed, I ought not dwell longer on this, for President Lindsley, in his annual message has alluded most appropriately to the matter. Many of the delegates came in last night, and it is but common justice to the Secretary and the Local Committee of Arrangements to say that their joint efforts for the accommodation of the visitors were of the most satisfactory kind. The Body House presented the appearance that such hotels always take on when they have been selected as the trysting places of the gas men. I do not know whether such an impression is the general one, but it always seems to me that gas men, whenever assembled on like occasions, look as if the world had used them kindly. The prevailing personal characteristics are: More than the average height, well above the average avoirdupois, and well beyond the average age. There is no gainsaying the fact that gray hair is fashionable at the Association gatherings. Not that the ubiquitous youngster does not also have a chance to show himself. He is there, but is usually not forceful. The first day's proceedings were marked by much earnest work, and President Lindsley proved that he is not only a good gas maker, but that he is a capable director of conventions as well. The attendance was perhaps not far short of 60, and there was a goodly contingent of visitors, including not a few from the East. Secretary Butterworth was more than pleased at this response to his earnest preliminary work, and Charlie Faben beamed with smiles—and a jolly smile is his. Few appreciate the real sacrifice that President Lindsley had to make in preparing for his duties in connection with this meeting. Severe illness in his family, with all that that implies, was his portion, and with rare fidelity to the Association's interests he served in double harness, without complaint. Is it any wonder that the Association prospers when its members make such sacrifices on its behalf? His address was of the practical sort, and his remarks in respect to the varied influences for good that mutual association has upon the gas industry are vigorous and bright. Take it all in all, it is a good paper, and will well repay a careful reader of its lines. As to the regular papers, they bore out the promise of their titles. Faben, as usual, in his treatment of 'Graduated vs. Uniform Rates,' was frank and outspoken. In fact, it seems to me that the single scale theory finds fewer advocates every year, and as the average rate for gas decreases, I think the chance for argument in favor of the all-round rule grows smaller. One of the best papers yet presented by Mr. Wilkiemeyer (and that is saying much, for everything that can be

traced to his pen in the shape of communications to the Ohio Association have been really models) was his compilation on the subject of the 'Municipal Control of Lighting.' Of course I cannot go at length into it; but let me quote a single sentence—not exactly as he wrote it, but so arranged that I can carry the meaning through without taking up too much space—in order to show the aptness of his reasoning. The lines are these: 'The capital of a city is derived primarily from the pockets of the people; secondarily, from the vaults of the city treasurer. It is not an exercise of solid political economy to allow the people's money to be invested in a commercial undertaking,' and "no man should be willing to be taxed in order that a city should secure capital with which to strangle private enterprise." If the political stranglers who are now agitating for the supply of gas and electric light by the cities and towns of Massachusetts could, through the medium of the constituents whose interests they misrepresent, be shown the potency of this argument, they might not be so willing to engage in an attempt through corporate force "to strangle private enterprise." Labor cannot look to its just due from public employment, for private capital has always been its savior. The paper by Mr. Hyde, Sr., on the new coal gas works at Cleveland, is after the manner of its author—precise, cool and accurate. To me, however, the moral of it all—and I think his view will be shared in more fully, when a score or more of Utopian fuel gas schemes have been exploded—is contained in its closing words. Having said that in his opinion the new Cleveland plant was of the best type, he quaintly remarks, "And is well provided to produce the most effective gas fuel, as well as the most practical medium of artificial light." In other words, the engineer of the near future will not require two plants for the manufacture and distribution of lighting and fuel gas—any more than he now does. Given a perfect manufacturing plant, his next step is to improve to the full the methods of using the product. The point of consumption is the one for the sharpening touches of the student and the inventor. Mr. Light's paper on the "Advantages of a Combined Coal and Water Gas Plant," strongly favors the affirmative side of the proposition; and Mr. Hedge's "Street Lighting Statistics" bears the evidence that care, thought and correspondence accompanied its compilation. The statistics are given in neat tabular form, and are likely to be hoarded for reference by all those who shall read his paper. I have not heard the remaining papers listed, but these will, of course, appear in due season, as will the contents of the "Question-box," which have been greatly increased since the publication of your last "Official Notice." The gas apparatus exhibition is a good one, and cannot fail to result in material benefit to those who have goods on display. The arrangement of it is admirable. To-morrow will be occupied largely in paying visits to the exhibition, to the showrooms and factory of the Central Chandelier Company, and to the plant of the Toledo Company's gas and electric light works. In conclusion, I may say that the Ohio Association's course is still onward and upward.—*.*"

"Thursday, 8 P.M.—The remainder of the proceedings may be classed as on a par, at least, with what I sent you respecting the instalment of the first day. The Association roll was increased by the addition of no less than 30 names, and this fact tells the story of the Society's vitality. It has been decided to hold the next meeting at Zanesville. The officers elected are: President, Chas. R. Faben, Jr.; Vice-President, H. Wilkie-meyer; Treasurer, Geo. W. McCook; Secretary, Irvin Butterworth—a right good working staff. The interest in the meeting was well sustained. The outing time was not over-enjoyable; and the banquet was as it should have been. Permit me to remark in closing that Lindsley is a most capable hand at directing the affairs of a meeting.—*.*"

A WEEKLY EDITION OF THE ELECTRICAL ENGINEER.—It gives us satisfaction to be able to say that the *Electrical Engineer*, hitherto published in this city as a monthly review of theoretical and applied electrical science, will, from and after April 1st, be printed weekly under its former management. This paper was conducted in a manner peculiarly acceptable to the interests which it represented, and as an earnest that this course is to be pursued in its entrance upon a wider field, we have only to remark that its old-time conductors, Mr. F. L. Pope and Mr. G. M. Phelps, are still to remain at the helm. They have, however, associated with them Messrs. T. Comerford Martin and Joseph Wetzler, whose names are guarantees that what was good before shall be even better in the future. We hope that the *Electrical Engineer* will reap the reward that comes from honesty of expression and unprejudiced treatment of the interests it seeks to serve.

MR. WILLIAM H. McCLAVE, of Newark, N. J., died at his home in that city on the morning of the 15th inst. He had been a resident of

Newark since 1850, and was a Director in the East Newark Gas Company.

MR. GREENOUGH ON MUNICIPAL LIGHT SUPPLY.—At an adjourned meeting of the Committee on Manufactures (Massachusetts Legislature) Mr. C.P. Greenough appeared in argument against the Bowers proposition to authorize the municipal authorities of cities, towns and villages to engage in the supply of artificial light. He declared that the proposition means spoliation by the Nationalists. The bill submitted contains no provision requiring the purchase of the gas companies, an omission which means ruin to the companies and to their stockholders. The scheme involves socialistic tyranny, and the petitioners do not represent the people, but only that portion of the people under their own hats. Mr. Greenough said that no cities, or towns ask for this legislation; it was only a part of the programme laid out by the Nationalists to place the railroad, telegraph, express and all other business in the hands of the Government. The proposed legislation was calculated to tempt towns to engage in speculative enterprises, and it would prove a source of political jobbery here, as it had in Philadelphia, Richmond, Wheeling, and elsewhere.

President Peaty's Views on the Status of English Lighting Methods.

The following is abstracted from the annual address of President Henry Peaty to the Midland Association of Gas Engineers:

During the past year, many things have happened which compel us to examine seriously the conditions of stability of our gas undertakings. Our rivals, if they have not actually increased in number, have developed in strength and activity. Some of them may be passed by without much consideration; to others, we must give our respectful attention. The language used formerly in describing electric lighting, and in estimating its value and prospects of success, must be considerably modified. Many of the defects which have been pointed out in past years, no longer exist; and those that remain have the attention of accomplished engineers, who are exerting every energy to effect their removal. We can no longer speak of the impossibility of bringing the light down to an illuminating power that would be generally useful; that it does not admit of regulation; that it is variable and uncertain (I am now speaking of the glow lamp supplied from accumulators); and that the color is more trying and wearying to the eyes. In many respects, it is a most beautiful light; and the way in which it can be adjusted to any portion of a room—ornamenting as well as illuminating—commends it to those who have a delight in beautiful adaptations, and who are not confined to the economical aspect alone. At present, it cannot compete with coal gas in economy; it is to some extent a light of luxury. But many people like luxurious appliances, and can afford to have them. There is such a thing as fashion. What is fashionable will be sought after; and, in many places, good and useful as gas has proved itself to be, and still is, the newer light will find a place. The gas will be removed, or relegated to the humbler offices of the house or mansion. Any one who has money and taste enough to adorn his principal rooms with valuable pictures and other decorations, would not hesitate to illuminate them, wherever practicable, with the light that would least interfere with their valuable contents. I do not anticipate that this method of lighting will take a large proportion of the lighting business of the country; but it is almost sure to encroach somewhat on our domain, and we shall have to bestir ourselves to make good any loss that may occur.

The use of oil lamps is extending; and though there is some inconvenience in the trimming and some risk, many prefer oil lamps to gas on account of their soft and agreeable light. It is claimed for the oil lamp that the light is cheaper, the wonderful improvement in burners enabling the consumer to get a most agreeable illumination at a moderate cost. The fittings have been improved to a remarkable extent; many of the designs of fittings, glasses and shades leaving nothing to be desired in the matter of decoration. Many of these fittings are cheap; and being portable, they are bought by consumers who would not go to the expense of gas fittings in their dwellings. The way in which we may compete for the custom of this class of consumers will be dealt with further on.

Of water gas—either used in manufactures, or in conjunction with oil gas for the purposes of illumination—I do not entertain the slightest fear. Whenever the conditions of the oil market allow gas to be made so as to compete with our ordinary coal gas, no one will be in a better position than ourselves to make use of it and supply it to the public. At present there is no firm of importers of oil who can quote a low enough price for either British, American or Russian oil to enable us to work it economically. When the supply of oil is sufficiently copious and low enough in price we shall be able and willing to deal with this mode of manufacture.

OFFICIAL REPORT.—REVISED BY THE SECRETARY.—[CONCLUDED FROM PAGE 362.]

TWENTIETH ANNUAL MEETING, NEW ENGLAND ASSOCIATION OF GAS ENGINEERS.

HELD AT YOUNG'S HOTEL, BOSTON, MASS., FEB. 19 and 20, 1890.

SECOND DAY—FEB. 20—MORNING SESSION.

REPORT OF COMMITTEE ON PRESIDENT'S ADDRESS.

Mr. Lamson—The committee to whom was referred the President's address would report as follows :

The committee heartily recommend to the Association a careful consideration of the many valuable and interesting matters contained therein. They coincide with the President's views in regard to the fairness and courtesy always displayed by the Gas Commission, and the value of the services of that body, both to the public and to gas companies. They respectfully refer back to the Association, without report or recommendation, that portion of the address advising the appointment of a committee by the Association for the consideration of legislation, etc. They further recommend the printing of at least 250 copies of the address for distribution among the members of other societies.

FRANK S. RICHARDSON, }
CHAS. D. LAMSON, } Committee.
HENRY B. LEACH, }

Mr. Lamson (continuing)—In presenting this report I would like to say that I am not the chairman of this committee ; that Mr. Richardson is the chairman, and that I was asked to present it for the reason that I yesterday afternoon felt called upon to make a few remarks with regard to a part of the address ; but I want this morning to commend this address most heartily to the Association, for I believe that it is written exceptionally well, and will prove a valuable paper for future reference. I also want to say a word with regard to two points mentioned in this report. First, the Gas Commission. They have been referred to by the President in pleasing terms. I most firmly believe in the Gas Commission, and in the value of their work. In a general way I have believed that their work has been in the right direction ; but I feel rather called upon to draw the attention of the Association to one matter which I understand they have in their report, and which they are bringing before the Legislature at this session. Last year there was legislation in the matter of the limit of the amount of carbonic oxide in gas. The limit that has been allowed in Massachusetts is 10 per cent. After much legislation last year it was left in this manner—that the limit should be 10 per cent., but the Gas Commission were allowed to increase that limit if they saw fit, if, when they granted a license to increase the limit, they would guarantee the safety of the gas which contained the increased limit. No three men would assume that responsibility, and no license has been granted. If I understand the recommendation of the Gas Commission to the Legislature this year it is something like this—that the Gas Commission generally shall have power to grant licenses to manufacture water gas in various towns in the Commonwealth, the limit of carbonic oxide being something like a sliding scale. That they may allow town A to manufacture water gas with a limit of 10 per cent., town B with a limit of 15 per cent., and town C with a limit of 20 per cent. ; that they shall use their careful judgment in the supervision of the matter, and that they may at any time, if they see good and sufficient reasons, revoke the license and prohibit a corporation in a town from making water gas, and I suppose refuse the right to make it, or the right to make it under the limit which they have granted. Of course, this Association can pass no resolution, or take any action to influence the Gas Commission, and do not wish to do so ; but I wish personally, in making the report and in speaking of the Gas Commission, to draw attention to that matter, and to this particular bill which they are introducing before the Legislature. It seems to me that all our Legislatures would do well to act in this matter, and to place a decided limit upon carbonic oxide. What that limit should be I am not prepared to say ; but whether the limit be left at 10 per cent., or increased to 15 or 20 per cent., I believe that it is for the good of the companies in Massachusetts, and also for the good and happy contentment of the Gas Commissioners for the years to come, that the limit shall be established by the Legislature and not by the Gas Commission. It will bring no end of trouble if the Gas Commission are going to allow one of you gentlemen to make 20 per cent., and limit another to 10 per cent. of carbonic oxide. They would hardly have time to attend to any other business during the year. I hope that when the question comes up, and they present it to the legislature—as they are supposed to be called upon to do very soon—they will see that it is a wise thing for them, and a good thing for the

companies, that they recognize some one limit that is, in their judgment, the right one, and let that limit be the same for all. In the latter part of this report of the committee we refer back to you the suggestion of the President that a committee be appointed to look to the question of legislation and to help out in the matter. I most firmly believe that the Association, as an Association, should let legislation alone—that they should not in any way, shape or manner touch it ; but let each one of us in the towns where we live watch the legislation and do what we can to influence it. But as an Association, I think that we would make a great mistake if we should in any way try to influence the legislation of this State.

On motion of Mr. Stiness the report was accepted and placed on file.

The President—That matter being left in that shape, no further action is necessary. A matter similar to that has been brought to the attention of the President. It is with reference to the preparation of statistics for a census report ; and perhaps without entering into a discussion of the matter, if Mr. Foot, the special agent of the Census Department, is in the room, or Mr. Graeff, will explain to us what action individual companies may be asked to take with reference to that matter, we should be glad to hear them.

Mr. Graeff—I do not know that there is much to explain. The only point which I desire to call to your attention is a matter in which I think every member of the Association is as intimately concerned as is any government official. This will be the first time the gas industry will be represented in the census of the country. An attempt in this direction was made 10 years ago, as you know, but unfortunately Major Dresser died before his work was completed ; and consequently the gas industry stands as yet unrepresented as regards statistical data. I think it is to the interest of every manager, superintendent and engineer who has the good of his business or profession (as you may choose to call it) at heart, that the best possible showing, consistent with strict facts, shall be made. I would only ask that each of you consider and bear closely in mind the fact that nothing which is sent in to the Census Office will be made public in any way. The schedules sent out will contain some questions which you might consider impertinent, provided any publication was to be given to them ; but there will be no way by which Mr. Taber can find out anything that Mr. Harbison has been doing, or by which Mr. Humphreys can find out how Mr. Prichard is making gas. The figures will simply be entered as statistics, and the nearest approach to a division will be by States. Therefore I ask you to bear in mind that all the statements which you may make, and all the answers which you may give, will be treated as strictly confidential—not merely so by the census enumerator as a man, and as one of yourselves, but by the other sworn officials of the government, who could not divulge them even they wished to. I think if that fact is borne in mind there will be no difficulty in obtaining the showing which the gas industry is entitled to. That is the only point I wish to bring before the Association.

Mr. George F. Goodno, of Dedham, Mass., then read the following paper, entitled

A POINT OR TWO IN REGARD TO ILLUMINANTS DURING CONDENSATION AND PURIFICATION.

It is with diffidence that I come before this body of experienced men to acquaint them with facts with which they are doubtless familiar, but in working up the subject I have gained considerable information myself, which may be some excuse for inflicting this upon your attention.

A phase of the question of the advisability of using iron sponge for purifying purposes has led to the assertion, supported by some short experiments, that lime absorbs quite an appreciable portion of the illuminants, thereby reducing the quality of the gas so purified to the same candle power as that purified by sponge with its contained carbonic acid. No one has ever held that there is any chemical combination between lime and the illuminants, any more than there is between sponge and the illuminants. If there is *any* absorption, it must be purely mechanical in either case, and there appears to be no reason why one should absorb more than the other.

A well-known engineer has shown by a series of careful experiments, on an average quality of gas, that the candle power is reduced about one candle by the presence of 1.32 per cent. of CO₂ in the unpurified gas, or what would be the same thing in regard to the CO₂, that purified by sponge as against that purified by lime. I endeavored to attack the problem from a different quarter, after the the following manner :

Four or five cubic feet of unpurified gas were stored in an improvised holder made from an old governor. A portion of this was passed through a layer of good, fresh sponge about one foot thick, and a sample collected for analysis. Another portion was passed through a like quantity of moistened lime, and a sample likewise collected for an-

alysis. By this means there was no doubt that the composition of the crude gas before either method of purification was the same. This can be readily seen to be a most important point, and one not strictly observed in other experiments on record.

The analyses made were to determine the amount of carbonic acid and illuminants only. The apparatus used was the Hempel, which was exhibited to you last year, and its use so clearly demonstrated by Mr. Jones. It meets the requirements of an experiment of this kind in a very satisfactory way.

The sponge gas was treated precisely like the lime gas in regard to temperature of operation, length of contact with the reagents, etc., so that any error occurring in one would appear in the other, and would not affect the relation between the analyses.

The samples were taken over a period of six weeks, as will be seen by the dates, and comprise a very wide difference in per cent. of illuminants. Taken as follows:

	CO ₂ .	Illuminants.
Nov. 1.—Unpurified gas.....	1.0	4.1
Purified with lime	0.1	4.1
" " sponge.....	1.0	4.1
Nov. 2.—Purified with lime0	4.1
" " sponge	1.0	4.1
Nov. 8.—Purified with lime0	3.5
" " sponge.....	.5	3.7
Nov. 10.—Purified with lime0	6.7
" " sponge.....	1.8	6.7
Nov. 15.—Purified with lime0	8.0
" " sponge.....	0.7	7.9
Nov. 21.—Unpurified gas.....	.8	5.1
Purified with lime0	5.1
" " sponge.....	.8	5.1
Nov. 23.—Purified with lime0	6.2
" " sponge6	6.2
Nov. 28.—Purified with lime0	6.7
" " sponge.....	.5	6.8
Dec. 14.—Purified with lime0	4.8
" " sponge.....	.6	4.8

A glance over these results shows the amount of illuminants in percents. by volume to be practically the same whether purified by lime or sponge. But the candle power does not vary with the percentage by volume of the illuminants, for at least two reasons, viz.:

First, because of the different specific gravities of the various illuminants, belonging as they do to the naphthaline, benzole, and other series of hydrocarbons. Some authorities have said that the candle power varies according to the percentage *by weight* of the illuminants; and this looks much more probable when we observe the different specific gravities of those constituents:

Acetylene89
Olefiant gas97
Benzole	2.72
Naphthaline	4.42

A very limited variation in volume of the last two would make, as will be seen, a very considerable difference in candle power. In fact it seems, from a study of a large number of analyses, that the volume per cents tell us very little about the illuminants and the illuminating power of a gas.

The second reason is the influence and character of the accompanying diluents, as shown by the reports of the State Inspector. Two analyses in these reports show this fact very conspicuously.

	Candle Power.	Illuminants.	Marsh Gas.
No. 1.....	19.4	5.14	45.12
No. 2.....	16.6	9.20	30.61

In the first the low per cent. of illuminants compared to the candle power and the remarkably high per cent. of marsh gas. The hydrogen was nearly the same in each. The per cent. of illuminants in the second being nearly double that in the first, while the marsh gas is only about two-thirds. Another factor in the case is that No. 2 contained 12.3 per cent. of nitrogen and 2.2 per cent. of CO₂, while No. 1 had 3.5 per cent. nitrogen and no CO₂.

Furthermore, the 19.4-candle power gas was purified by lime alone, while the other evidently was purified by sponge—as a whole, quite clear negative evidence with regard to the absorption of illuminating power by lime.

Another point in which I became interested with regard to absorption of illuminants of the gas is in its passage through condenser and washer. Our condenser is a coil of pipe exposed to the air, and the washer a rectangular iron box, with alternate shelves, and is familiar in small works.

I wished to determine if there was any loss of illuminants to the gas in its passage through these two pieces of apparatus, especially when there was a relatively large amount of water running through the washer. For this purpose a sample of gas was taken after passing through the exhauster; then, by a rough calculation of the capacity of the apparatus between there and the outlet of the washer, I determined very nearly by consulting the meter when the same gas could be sampled again. The two samples were then analyzed for illuminants. Several pairs were taken in this way, and different qualities of gas on different days. The results were as follows:

	CO ₂ .	Illuminants.
Before passing condenser and washer.....	1.4	4.3
After " " "	1.4	3.9
Before " " "	1.5	5.6
After " " "	1.5	4.9
Before " " "	1.0	4.1
After " " "	1.0	3.8
Before " " "	2.0	6.1
After " " "	1.8	5.7
Before " " "	1.4	4.3
After " " "	1.4	4.3

Average loss..... .36

I was then using about 4 or 5 gallons of water to the 1,000 cubic feet. The pressure of other duties prevented me from making further analyses, using less water, as I intended.

Discussion.

The President—You have the figures and the facts before you. Has Mr. Gifford any figures which he can compare with those given by Mr. Goodno?

Mr. Gifford—I have no figures, but I will say that I am pretty certain from my observations that these facts are very generally true, and in a good many cases the percentage is a great deal larger than he has stated.

Mr. Prichard—This paper is valuable in settling in my mind a point which has been often spoken of the relative absorption of illuminants in oxide and lime. I have in mind two papers, both taking opposite and different grounds from this paper; and it seems to me, from the care that Mr. Goodno has taken in his experiments, he proves that both those gentlemen are wrong; and he settles in my mind that there is no absorption of illuminants by the purifying material.

The President—I know it has been the prevailing idea that the use of iron sponge was a detriment to candle power. Has any one made any experiments to prove how much of a detriment it is?

Mr. Jones—I think that Mr. Goodno's paper is a valuable addition to the literature of gas purification. He has voiced an opinion which I have had for some years with regard to this matter; but my good friend Mr. Blodget, of Williamsburgh, tried a series of experiments, the results of which he put in the form of a paper and read before the American Association, which were directly contrary to Mr. Goodno's results. Granted that the absorption of illuminants by the passage through the lime is merely a mechanical action, I see no reason why 12 inches of lime should absorb illuminants, if 24 inches of sponge, closely packed together, does not absorb the illuminants. I have a few figures here which relate to another portion of Mr. Addick's paper, but which I think may be of interest. Last spring I was using at the North End station of the Boston Gas Company what is known as the Baby process—the bootleg retorts. We used the process for enriching our coal gas, using oil and steam in the presence of incandescent lime. I found that there was some loss by not running the water gas process on Sunday, on account of cracked retorts, etc.; and so I decided to run the water gas plant on that day. This gave me oil gas, which I put into the holders and mixed up with the coal gas of low candle power which was made during the early morning hours of Sunday. I thus had an opportunity to find the difference in candle power between the unpurified oil gas, and the condensed, washed, and purified oil gas as it went through the station meter of the works. It has been very aptly said that no man knows what there is in a gallon of oil, and I believe that that is true to-day. I hope that some day we will find out what there is in a gallon of oil, and naphtha as well. I have some figures giving the candle power of crude oil gas made in the bootleg retorts directly after it had passed a washer which was inadequate for the purpose, and the candle power after it passed through the station meter. One hour the candle power of the crude gas was 24.5, and at the station meter 21.5; the next hour the crude gas was 24.5, and the purified gas 21.5; the next hour, crude gas 23, and the purified gas 21.5; the next hour, crude gas 23, and the purified gas 20; showing that there was a loss of about 3 candles in fixing that gas in order to send it out to our consumers. Is there not some way

that we can get that 3-candle power back into the gas and deliver it to our consumers as it should be?

The President—Can anyone answer that conundrum?

Mr. Harbison—I suggest that Mr. Jones tell us next year at what points this loss occurs, if at more than one point, between the bootleg retort and the station meter; and if he will make his test at various points between those two points I think he will be able to solve the question.

Mr. Addicks—I would suggest the possibility that the loss is before you get to the scrubber and washer at all. In other words, that it is by reason of not heating the gas to a proper temperature.

Mr. Humphreys—We have been making some experiments in this same line, and I am sorry that I have not the exact figures with me. We make, as you know, a mixture of coal and water gas, and have been endeavoring to see whether there is any loss of candle power in the passage of the gas through the works. We have been making these experiments now running over three weeks, taking the candle power and analyzing the gas at points next to the hydraulic main, and prior to the condenser, and prior to the washer, and prior to the purifiers; and we do not find any loss either in candle power or in illuminants in the passage of gas through the works.

Mr. W. A. Wood—Have any members noticed a difference of candle power when using fresh sponge and when using old material? Our experience has been that when running on old sponge which has been used for several months we get a certain candle power, but if the box were filled with new material there would be a depreciation. There is a question in my mind whether the more active sponge does not effect some chemical change in the illuminants themselves.

The President—Possibly the greater heat of the reaction of the iron itself at its first start off might depreciate the illuminants.

On motion of Mr. W. A. Wood, the thanks of the Association were voted to Mr. Goodno for his paper.

The next paper was read by Mr. W. H. Snow, of Holyoke, Mass., entitled—

A CHAPTER OF DON'TS.

Mr. President and Gentlemen:—During a somewhat extensive experience in the past twelve months with an old stack of benches, some faults of construction were so forcibly brought to my notice that I jotted them down for future reference, in order to guard against a repetition of same in case of possible rebuilding. When the invitation came to prepare a paper for this meeting I wrote them out more fully, hoping some one might get a point or two for his benefit. The points are put in the form of "don'ts," as the writer does not wish to undertake to say what is the best way of obviating the faults. While he may have his own opinions in the matter, he prefers to leave the solution of the questions to the judgment and discretion of his hearers.

There is no portion of a gas works that it is of more importance to have well constructed than the stack of benches, with the bench settings. It is a case where the cheapest is not always the most economical. Sometimes in building a new stack a few hundred dollars invested above absolutely necessary expenditure will be returned more than a hundred fold. To begin at the beginning, look well to the foundations; don't neglect them; don't under any circumstances have them weak. Those who have never been there have no idea of how the heat strikes down through them. In excavating the past season to put in some deep furnaces under an old stack, it was surprising to find how hot the earth was under a bench that had not been run for a month, and had all been torn out for two weeks. The foundation was a solid block of masonry 3 feet in thickness, built of flagstone 6 and 8 feet long by 3 to 5 feet broad, and from 6 to 9 inches thick. The dirt was so hot for a depth of 3 feet under the flagging that it could not be handled until it had been cooled; in fact, it was sissing hot when water was run upon it. You probably are all familiar with the instances where bench work has been built upon piling, and the piles have burned off so much as to ruin the stack. The stones themselves get so much burned that they appear like rotten stone one can pick up in the fields; hence it is necessary not to have the foundations too thin. Don't use poor flagstones; anything or everything will not do. An expensive foundation is a good investment.

Next comes the brickwork, the arches and their covering. Don't scrimp on room. Don't be satisfied with low, narrow, shallow arches. There seems to be a growing demand in every succeeding year for more room in the retort house. Do you realize the economy in fuel and labor secured by large retorts? I have frequently seen a bench, with all the coal it was practicable to put into it, so hot that if there had been room to put it, it would have easily burned off 25 or 50 pounds more to a retort with no more expenditure of fuel or labor. If plenty of room can be had, next look sharply after the brickwork. Don't accept any second-

class bricks, don't allow any large joints, and don't have any red bricks anywhere near a flue. Have you ever, in the case of a stack that had settled and apparently shrunk, and appeared upon the point of collapsing, investigated the causes therefor? Were there not some soft burned brick, broken and ragged from the handling during the transportation, somewhere in the structure, either just at the top of the foundation, or in the piers supporting the arches, that were not strong enough to stand the strain of repeated contraction and expansion, and had crumbled, helping on the settle? Were there not places, perhaps out of sight, where there had been large joints? In leveling up, had not the masons, rather than spend the time and trouble to cut bricks to fit, filled up the spaces with a half-inch or more of mortar? There is but little strength or bond in fireclay mortar, so with large joints the conditions are even more favorable for settling than in the case of soft bricks.

Red bricks are another prolific source of trouble. My advice would be, don't use any, either in leveling up the foundations or filling up over the arches. By no means have any near the flues. While their use may have been perfectly practicable in the days of common old-style furnaces with lighter heats, with the changed conditions of the present heavy heats they will melt. How many of us have had occasion to cut from the bottom of the uptake flues a hard, lava-like substance, and traced the cause to the same red bricks? When they melt and run they must of necessity leave an empty space, to the detriment of the strength and stability of the block. I have recently seen on top of a stack with short chimneys a hole where the bricks had melted, extending from chimney to chimney, a distance of 17 inches, a foot wide and 15 inches deep. The safety of those chimneys was certainly jeopardized.

Don't by any means ever allow the tie-rods connecting the binder irons to be covered by the brickwork. They will most certainly burn off, the braces will spring out from place, and the arches begin to settle. What a feeling of discomfort possesses the manager when he observes this state of affairs and realizes that it is impossible to ever get them back into place again. I am glad to be able to state that the builders now-a-days appreciate this point and are keeping the rods uncovered.

There is a difference of opinion as to the desirability of short or tall chimneys. I will not attempt to say which is the better; but if the former are decided upon don't have them built directly over the up-take flues. What a source of trouble and expense such an arrangement is, those of you who have never had the experience have no idea. If it is in a double stack, the opportunities have to be watched for getting into empty arches to cut through back walls into the flues to clean them. With no such opportunity, there is a good chance of losing the bench before it is half used up. Be sure of a way of getting into the upright flues from the top.

After the stack is provided for there remains the most important part as affecting the results procured—the benches, the style of settings, and the furnaces. Don't put in old-style furnaces. It is positive extravagance so to do. It would be hard to tell which regenerative or recuperative furnace is the best, but it is safe to say any one of them is better than a common furnace. Our worthy Secretary requested me to write up my experience with recuperative furnaces; but my experience is so limited at present that I cannot give any facts or figures that would be of any real value to my hearers, though I am satisfied from it that no company can afford to heat their retorts in the old-fashioned way.

The first furnace we put in was in the fall of 1888, it being a half-depth recuperative one. With it we managed to burn our retorts all up inside of six months; but, notwithstanding this dismal result, we were able to gather some grains of comfort. The heat was there, the economy was there; we were on the right track. We found we must have a setting that would stand the great heat we could generate, as plain open settings would not do. With the retorts properly braced and protected, we could handle it. While the retorts were in good condition in this bench, we were able to make an average of 8,971 feet per retort, or 53,826 ft. for the bench in 24 hours, burning off 300 pounds of coal in four hour charges, with a consumption of 60 bushels of coke. We ran as high as 9,864 ft. per retort, or 59,184 ft. for the bench. The retorts were 14 in. by 26 in. by 9 ft. As was said, we were convinced we were upon the right track.

This last summer we excavated and put in three deep furnaces, starting the first one last October. We have burned off 2,000 pounds in four-hour charges, with a consumption of 60 bushels of coke in 24 hours (reckoning 59 pounds of coal as making a bushel of coke), making something over 60,000 ft. of gas to the bench, or 10,000 ft. per retort. Using 1,900 lbs. of coal to a charge is a comfortable every days' work, while 1,800 lbs. to a charge is only play. In this bench, the four upper retorts are 14 in. by 28 in. by 9 ft., and the two bottom ones are 14 in. by

26 in. by 9 ft. These furnaces are very simple recuperative ones, with both primary and secondary air supplies heated but very little compared with some of the more complex regeneratives.

Do we have any trouble with them? Yes, some. They require attention as well as common fires; but if the stokers were to be asked which style they preferred, they would undoubtedly choose these. We are able to run with clinkering twice a week; that is, either driving the secondary bars, or letting the fires down so that the fire-boxes can be cleaned all out. The latter we do upon Sundays, when not making gas, so we do not lose our heats. Of course, we run the slicing bars into the fires occasionally to break up the clinker. That is about all the trouble we have. The fires are very easily controlled; the labor of firing is comparatively light, as we fire with hot coke, so it is only a part of the charging. What have we gained? We have increased our make per bench from 45,000 ft. to 55,000 ft. per day. The latter figures are placed low purposely, as being a fair average for all the year around. We have reduced our coke consumption from 47 per cent. to 33½ per cent. These figures I do not give as anything wonderful, for they do not approach some that have already been given you in years past; but I consider them practical, every day results, that can be obtained with ease and comfort, without stopped stand-pipes or pitch in the hydraulic mains, and going to show the desirability of adopting some one of the improved methods of firing.

About the life of the benches I cannot say, as I have said, my experience is too limited; but if as much gas can be made under present arrangements in three months less time than formerly, adopting them will have been good business policy. There will be three months' labor that will not have to be paid for and three months' consumption of fuel saved.

If improved furnaces are adopted, look out for the settings; don't have them weak. Open settings, that will do for ordinary fires, will not answer for the increased heat. Do not allow bricks and tiles to be laid too wet; thereby avoid a prolific cause of cracks. The suggestions made at the last meeting of the American Gas Light Association, in answer to the question, "How should fire bricks and tiles be laid?" are good ones to follow.

I do not know that it ever has been done, but I believe it possible with sound foundations, first-class materials, good workmanship, plenty of room inside the arches, and the brick work properly braced and tied together, to build a stack of benches that will last a lifetime.

Discussion.

Mr. Allyn—As Mr. Snow has laid considerable stress on the matter of the economy in the consumption of coke, I would like to ask him whether he estimated his coke at the rate of 59 pounds to the bushel. It seems to me that that is a greater weight than any of us have ever reached.

The President—He estimates 59 pounds of coal as making a bushel of coke. The English find that a little over 60 pounds of coal produce a bushel.

On motion of Mr. Lamson the thanks of the Association were voted to Mr. Snow for his paper.

THE WORLD'S FAIR.

Mr. Prichard read the following report of the Committee on World's Fair:

The Committee appointed upon the World's Fair would report that they cordially approve the suggestion that the gas industries of this country be suitably represented at the proposed World's Fair; and they would recommend that Messrs. C. J. R. Humphreys, A. B. Slater and John P. Harbison be appointed a committee on behalf of this Association to act in connection with committees appointed by other Associations; and that such committee act without compensation, but that their actual expenses shall be paid from the treasury of the Association.

On motion of Mr. Stiness the report was received and accepted.

On motion of Mr. Neal the recommendations of the report were adopted and the committee appointed.

BADGES.

Mr. Stiness—On consultation, the Committee on Badges have decided to adopt the monogram of the New England Association. The Committee ask to be continued. They recommend that the badges be paid for by the members. It is perhaps proper that the badges be procured in the name of the Association, as it would be desirable for the Secretary to retain some in his possession. The price will not exceed \$3, and we will get them for as much less as possible. I move that in this matter the Committee be continued, and that when they make a report they report to the President; and if acceptable to the President and Board of Directors, that they be authorized to procure the badge. I do not feel

like throwing the responsibility of procuring the badges upon the Committee alone, without any consultation or advice.

On motion of Mr. Anderson the report of the Committee was accepted and the recommendations adopted.

QUESTION-BOX.

The President—I was afraid that, owing to the press of other business, our Question-box had been neglected. I was quite surprised the other day, on talking with some of the electric light gentlemen, that they alluded to the Question-box as one of the most interesting features of this Association. We can very well put in there questions as to anything which is troubling us, or as to which we are in any doubt, and get an answer to our queries. That seemed to the electric light men a wonderful thing. I will read the questions which I find in the box.

"What is the effect on meters of the use of crude oil as an enricher?"

Mr. Prichard—We find that when the oil is thoroughly fixed it has no effect that I am aware of.

Mr. Lamson—Crude oil has been used only for a comparatively short time, and I can hardly venture an opinion. We had all formed an opinion in advance with regard to the effect of naphtha on the meters—that it would be injurious; but I do not myself believe that it has been injurious to any great extent.

"How many days is it best to allow for the payment of gas bills?"

Mr. Fowler—In Westfield we wait 5 days.

Mr. Harbison—Five days, not counting in the day that the bill is delivered, Sabbaths or legal holidays.

Mr. Coffin—We allow 15 days, but about all the business is done in about the last two days.

Mr. Tilton—Ten days.

Mr. Cogshall—Ten days.

Mr. Allyn—Twenty-five days, with the addition of 25 cents per 1,000 after that.

Mr. Sherman—Ten days.

"What dissatisfaction, if any, is caused among regular customers by making a reduction to users of gas stoves?"

The President—As I understand that question, it is, supposing you allow a gas stove man to have his gas at one dollar, how much dissatisfaction is caused when he comes to pay for his illuminating gas at \$1.50? Is the practice adopted in any of our New England gas companies of making a differential gas price on gas for illumination and heating?

Mr. Anderson—Our practice has been to charge \$2.50 for illumination and \$2 for stove.

Mr. Fowler—Is there any difference made in the price of gas for power and for illumination?

The President—I think there is no question about that. Who has gas engines in use?

Mr. Goodno—We allow a discount of 50 cents per 1,000 from the regular price for stoves, engines, etc., and we find that it is gratifying to the consumer; and it does not seem to react the other way and make him complain of the higher rate. I have not heard anything of that kind.

Mr. Harbison—I do not believe in the theory or principles of making a price for different uses of gas. I do not think that it ought to make any difference to the gas company whether the consumer uses gas for power or for heat, or for illumination. If you do make a difference in your price for different uses, you are making trouble with your customers. You make one man pay more who uses a large quantity for illumination than his neighbor pays for a small quantity for running his gas engine. If you begin to make a different price for the use of gas according to what it is used for, it increases the number of meters, and that is very objectionable on account of the expense involved. But you must do that in order to determine the quantity used. I think that both the principle and practice are wrong. I think that gas should be sold for all uses at the lowest possible rate.

Mr. Neal—I think it is a very good plan to make special rates for special consumers. We do it for gas engines and we never have had any trouble arising from it.

Mr. Coffin—We have three or four gas engines, but I believe that to the largest (a ten-horse power engine) we do not sell over three thousand feet per month; whereas we have some consumers who use three times that amount for illumination. I think that a consumer would have a just cause to complain that a party using only one-third the gas that he did could buy it a lower rate.

Mr. Greenough—I agree with Mr. Coffin. I do not think it is fair to discriminate against our principal consumers of gas for the purpose of

building up a trade. The question has been very carefully argued on the other side of the water; and in Brussels at the present time, I think, they have a meter which works in different compartments, according to the amount of pressure put upon it; and that for the gas used in the day time they charge one price, and charge another price for the gas used in the night. According to that plan, those who use gas in the day time get it for less money, and I think it is fair; but I think it is not right to turn against our principal consumers by selling gas to the small consumers for a less price. The question was brought up in the South Metropolitan Company, in London, and argued fully by Mr. Livesey, who maintained that the principal purpose for which gas was made was for illumination, and that if anybody was to get his gas cheap it should be the person who used it for light; and that to sell it to any one else at lower prices was to discriminate against the ordinary consumers in an unfair way. I must say that I think he was right in that view.

Mr. Coffin—We have in use over one hundred gas stoves, and last year they averaged a little more than \$10 net, each; but after setting a separate meter, and doing all the additional work required, and then sell a party only \$10 worth of gas per year, if we were obliged to do that at much lower prices than our regular price, it would seem to me to be bad policy.

Mr. Todd—I think the better way is to have a sliding scale, and let the largest user of gas, whether for illumination, power, or heating, have the biggest discount.

“What is the best material and manner of repairing leaks temporarily in holders?”

Mr. Coffin—I am using red lead, making it quite soft, one component part being shellac.

Mr. Allyn—I know of no better cement than one made of glycerine and litharge. It sets very quickly, is elastic in a measure, and after it has set it is very hard and very tenacious.

Mr. Anderson—I have had a little experience in this line. My holder, where the sheets were riveted together on the side, rusted out in places 8 and 10 inches long, so that the gas came out freely. The iron was so rusty and corroded that it was almost impossible to hold the cement on the sides. I took a lot of canvas duck and shellacked it, laid it over the break, tapped the canvas in the center so as to allow the gas to escape while the canvas was setting on the larger portion of the break; and after it had set closely on the holder I had no trouble in sealing up the small hole I had made in the canvas. It ran along for a year without trouble.

Mr. Harbison—Some years ago, during a severe snow storm, the top of one of the Hartford holders broke, and in coming down cut a hole in the side of the holder 16 inches long, five sheets from the top. We put a plate of iron on the outside, and it has remained there to this day in good shape.

Mr. Tilton—I have, during the past year, repaired one holder by soldering, where the leak was considerable. I first scraped the sheet, then thoroughly tinned it, and made a complete and good job by using soft solder. I have repaired a dozen different places on the holder in that way.

The President—Those are all the questions there are in the box. Are there any others which any one wishes to ask?

Mr. Addicks—I would like to ask for a method of preventing the gasfitter putting on 2-foot tips to save gas bills.

Mr. Coffin—One way to do it is to do your own fitting, and do it at such a price that the gasfitter cannot touch it.

The President—We get over that difficulty in the same way.

Mr. Harbison—I think if gas companies will provide a supply of burners that they can recommend as giving a good light for the quantity of gas consumed, and sell them to consumers at cost, they will have very little difficulty from any party putting on inferior burners. We have adopted that course and found it to work very satisfactorily indeed.

Mr. Lanc—We have adopted the plan of furnishing the consumer with tips, and I think it pays to do so.

Mr. Anderson—I would like to ask the opinion of the Association as to what burner they consider the best to adopt to be sold to the consumer at cost. I have tried a number of burners of different kinds, and finally have come to the conclusion that the Bray burner gives the best satisfaction, and gives more light, for the amount of gas burned, than almost any other I have tried.

Mr. Addicks—We tested a large number at Chicago at one time, and found that they were apt to stop up.

Mr. Coffin—We adopted the Bray burner at one time, but found them hard to clean out.

Mr. Boynton—I would like to ask what is the effect of varying tem-

perature and varying density in the registry of candle power upon the jet photometer. Perhaps Mr. Jones can tell us.

Mr. Jones—I have no figures at hand which I would like to give in answer to that question.

Mr. Prichard—I suppose the gentleman's question has reference to whether it is plain coal gas, or a mixture of coal and water, or coal and oil. I think that Mr. Jones can explain better than anybody else why photometers have to be adjusted for different densities of gas.

Mr. Jones—The jet photometer which I make is adjusted for all ranges of density, so that the instrument is approximately correct, as all photometers are. There is a great deal of dissatisfaction or fault found with photometers in general. The water gas photometer is of course made for a gas of greater density than coal gas, and is adapted to ranges of from 520 to 620; coal gas photometers are adapted to gas of a density in the neighborhood of 425, and oil gas photometers are adapted to gases of greater density.

Mr. Todd—I would like to ask what the members think is the best burner for street lights where there is a greatly varying pressure—say from 35-tenths to 25-tenths. The tips must be 4-foot. What is the best burner to regulate the pressure on street lamps?

Mr. Coggshall—The Springfield burner.

Mr. C. S. Spaulding—The city of Boston uses the glycerine burner, which we are using in Brookline; and after being on for three years, and having had a record kept, I know that they will burn within 0.02 of what they did when they were put on.

Mr. Harbison—Some years ago the city of Hartford was well lighted, as far as the streets were concerned; and at that time we were induced to put on a couple of dozen of glycerine burners for the purpose of testing them. They were 4-foot burners. We watched them very carefully, and in 20 days found that at least half of them were burning 10 or 12 feet.

VOTES OF THANKS.

The President—The papers which were prepared for us have all been read and discussed; the questions found in the box have been answered, and the work before us, so far as it was laid out by our absent Secretary, has been, as far as I know, thoroughly gone through. Unless some member has some business which would properly come before us, a motion for adjournment is in order.

Mr. Harbison—Before a motion to adjourn is made I wish to return special thanks, in my own behalf, and in behalf of the members of the Association, to our President, Mr. Taber, who has filled the chair at this session, and has performed the duties of his office during the past year to our entire satisfaction. He has been exceedingly courteous in his treatment of members, very thorough in his management of the business, very calm and deliberate in his judgments and decisions, and it is due to ourselves that we should place on record a vote of thanks to our retiring President, and I so move.

Mr. Stiness—I second the motion.

The motion was put by Mr. Prichard (President-elect) and unanimously adopted.

The President—Gentlemen, there ought to be a vote of thanks to you, rather than that you should give me thanks for doing what I have done so incompletely. I thank you most heartily for the courtesy you have extended to me. The absence of the Secretary necessarily threw a great deal of extra work upon us, and that he was not able to get here in time was a matter of regret to me; but your uniform kindness has enabled me to get through with the business. There has been but one subject brought up that has in any way tended to disturb us, and that has been treated in such a kindly way, and with such open, fair-hearted criticism, that I am very glad indeed that it came before us. I welcome it as a fact of a good deal of importance that we can criticise each other honestly, honorably and amicably, and state what we think, and why we think it. I have great faith in the future of this Association. I notice that our papers are getting more and more practical, more and more pointed, and that we are all getting more and more in earnest in the matters that come before us; and I trust this spirit may continue from year to year. I would remind you that we have had a Secretary *pro tem.* this year, who has ably filled the duties usually so ably managed by Mr. Nettleton; and I move that a vote of thanks be given to him for his kindness in attending to the duties of that office.

The motion was unanimously adopted by a rising vote.

Mr. Humphreys—I am exceedingly obliged to you, Mr. President and gentlemen, for your kind vote of thanks. I have recalled during the past two days our meeting at Baltimore of the American Gas Association, of which I am Secretary. You will remember that then, through illness, I was unable to take my usual place; but I received so much help from my friends at that time that the work went on without any

hitch, and that has made me all the more willing to serve you in the capacity of temporary Secretary during this convention.

PLACE OF MEETING.

Mr. Greenough—I move you that the Executive Committee of this Association next year consider the advisability of finding larger quarters for our meeting. The time was when the parlor of the Tremont House was large enough to hold us; then we came to this place; and now we have outgrown our present quarters. The ventilation of this room has been so poor that a number of our members have gone out because they could not stand it here any longer. I do not think there will be any difficulty next year in finding some small hall where we shall be more comfortable than here.

The President—I might say, in that connection, that in the proposed gas stove exhibition that we had on hand this year (and which was so heartily seconded by every maker of gas stoves), the great difficulty was in finding a place suitable. It was suggested in the course of the discussion that some such change as is now proposed should be made—not that we are anxious to leave our old home, for we are all familiar with this room, but because we are growing larger every day, and really need a larger room for our meetings.

The motion was carried.

The President—I wish to bring up something which has not been referred to yet, and that is that I think a vote of thanks is due to the local press for their fairness and care in reporting our discussions. It does not, of course, call for any response from them, but I will say that they have been very careful and accurate; and I think that a vote of thanks is due to them for their politeness towards us.

A vote of thanks to the local press was passed.

Mr. Harbison—It has been suggested to me that there has been no vote of thanks proposed, nor any fit announcement made with reference to the postponement of the entertainment tendered to us, and which has been postponed on account of the weather.

The President—That announcement was made in the early part of this morning's session, but I will repeat that, owing to the storm, it was not thought best to accept the invitation; but the thanks of the Association are due for the generous offer.

The thanks of the Association were voted to the companies extending the invitation.

On motion the Association then adjourned.

IN MEMORIAM.

The Committee appointed to prepare a memorial of our late associate,
MR. OLIVER E. CUSHING,

respectfully submit the following:

Oliver Edwards Cushing was born at Chelmsford, Mass., in March, 1829, and died in Lowell, Mass., January 17th, 1890.

He was one of the original members of the New England Association of Gas Engineers, and also one of the first Directors, but declined to accept the office of President.

He was also one of the original members of the Guild of Gas Managers, of New England, and served as its President two years. He was elected a non-resident member of the Society of Gas Lighting, of New York, in 1876. He was elected a member of the American Gas Light Association at its second annual meeting, in 1874, and continued his membership in these several Associations up to the time of his death.

He entered the service of the Lowell Gas Light Company as agent, in 1860, and continued with the Company until his death.

Mr. Cushing's lifework as a gas engineer was marked by success; and in all the various relations which he sustained to the business of gas manufacture, whether as a member of the several Associations, or as an officer, his course was always marked by a quiet dignity of manner, coupled with good practical judgment, which made him an agreeable associate and a wise and prudent counsellor.

In his death we feel that this Association has lost one of its most valued and worthy members, and that his memory will always be cherished by the most kindly feelings of all his associates.

(Signed)

SAMUEL G. STINESS,
A. B. SLATER,
C. F. PRICHARD, } Committee.

The Meyer Valve Indicator.

This apparatus, herewith illustrated (which is covered by United States Letters Patent, granted October 8, 1889), is known to the trade as the Meyer valve indicator, and its claim for consideration at the hands of gas engineers—that is, in respect to its especial advantage for their use

—is that it indicates clearly, from a simple glance, the exact state of the valve opening. In short, it presents a picture of the interior of the valve in the position most convenient to the eye of the person operating the valve. It can be applied to any valve—gas, steam or water—in any position howsoever hidden, and does not get out of order. Many of

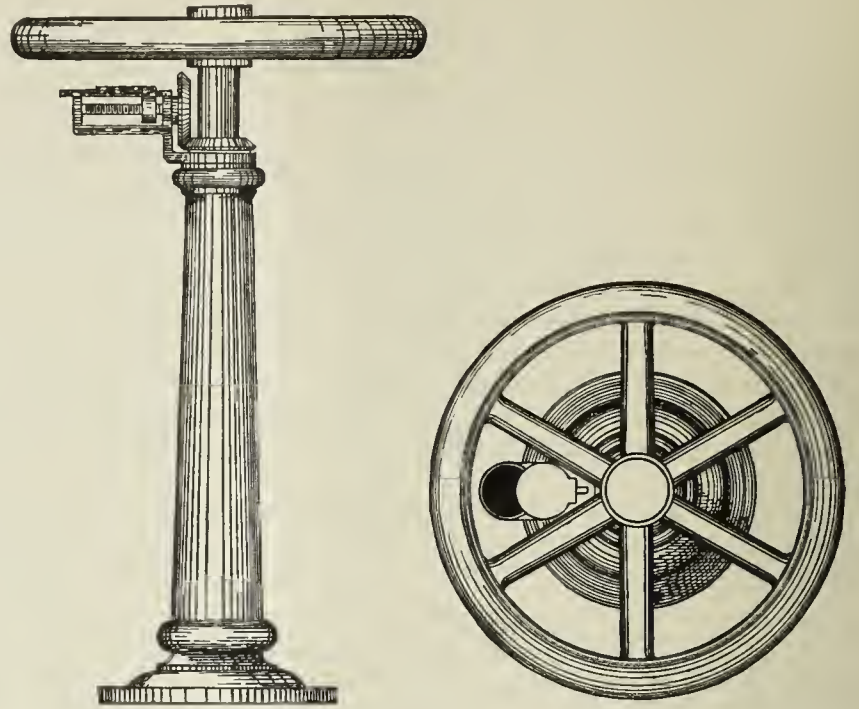

these indicators have been used for some time in this city and elsewhere, on valves from 12 inches to 30 inches diameter. For application in a valve room it is only necessary to know the size of the valve, the number of turns required to raise it completely, the diameter of the valve stem, and the distance from the top of the valve stem to the upper side of the flooring in the valve room.

Any additional information in respect to the Meyer apparatus may be readily obtained from Messrs. James R. Floyd & Sons, of this city, who are the sole manufacturers of the device.

The Manufacture of Oxygen for Industrial Use.

The *London Journal* reports that at a recent meeting of the Institution of Mechanical Engineers, in London, a paper on the above subject was contributed by Mr. Kenneth S. Murray. It described (with the aid of illustrations) the plant used by Brin's Oxygen Company, with which the author is connected, whose works in the Horseferry Road the members were afforded an opportunity of visiting. In view of the recent utilization of oxygen, manufactured by the Company's system, for the purification of gas at the Ramsgate Corporation Gas Works, on Mr. W. A. Valon's recommendation, and under his supervision, an abstract of the paper, and a short report of some of the remarks thereon, may be of interest.

The author commenced by referring to the discovery made by the eminent French chemist Boussingault, about 30 years ago, upon which the Brin process is founded—that monoxide of barium has the property of absorbing oxygen from the atmosphere when heated to 1,000° Fahr. (the result being a dioxide), and that the oxygen thus absorbed would be given off again at a temperature of about 1,700° Fahr.; the monoxide being apparently restored to its original condition. It was found, however, that the barium monoxide gradually lost its virtues as an agent for extracting and giving up again the oxygen in the atmosphere. The discovery consequently had no important industrial result for very many years, until the brothers Brin determined to turn the researches of their compatriot to commercial uses. The barium oxide, commercially known as baryta, is used in bleaching processes, and is therefore an article of commerce; but that which is placed on the market by manufacturers is not sufficiently pure for the purpose of oxygen manufacture. The baryta required was therefore made on the Brin Company's works; and its manufacture has been so far perfected that the difficulties encountered by Boussingault and others have been practically overcome.

The method of working is as follows: The baryta is placed in vertical steel retorts, and these are subjected to the heat generated by the burning of carbonic oxide from a gas producer, which forms part of the apparatus. The retorts are 9 ft. long and 7 in. in diameter; the metal being $\frac{1}{2}$ in. thick. In the plant described there are 24 retorts, which will hold 2,100 lbs. of baryta. Arrangements are made for

charging or emptying the retorts while in position. This is one of the recent improvements in the plant. Air is compressed in a suitable pump to a pressure of about 10 lbs. to the square inch, and is then delivered to the purifiers containing caustic lime and caustic soda, in order that the carbonic acid and moisture may be extracted. After leaving the purifiers, the air passes to the retorts, and the oxygen is absorbed by the baryta; the nitrogen escaping into the air through a release valve. When the peroxidation of the baryta has continued for the desired period (say, $7\frac{1}{2}$ minutes), the operation of the air pump is reversed by an ingenious automatic device which throws the purifiers out of the circuit by means of cocks, and the retorts are subjected to a vacuum of about 26 inches of mercury. Deoxidation of the baryta then takes place, and the gas thus obtained is stored in a suitable receptacle. The result is oxygen to the extent of about 96 per cent.

The cost of production, allowing for depreciation of retorts and baryta, is said to range from 2s. per 1,000 cubic feet in ordinary gas works, to 6s. 6d. in works especially erected for the production of oxygen only, where additional charges would have to be made for labor and rent. The demand for oxygen in retail business appears to be constantly increasing. In 1887, Brin's Oxygen Company sold from their works no more than 142,000 cubic feet for limelight and other purposes. The quantity sold in 1889 amounted to just 1,000,000 cubic feet, notwithstanding that the Manchester Oxygen Company have recently taken over the whole trade of the North of England.

The paper closed with a description of the high pressure cylinders in which the oxygen is sent out, and of the compressors used for charging them; and in connection with the industrial uses of oxygen, the author referred the members to the paper read by Mr. Valon before the Gas Institute in June last year.

In the course of the discussion on the paper, Dr. Thorne, the Company's Chemist, gave some additional information. He explained that the opinion which had been expressed as to the dependence of the process for its extensive application upon the successful manufacture of the steel storing cylinders, was incorrect; for the cylinders were only used in storing small quantities for such purposes as limelights, etc. Wherever the use of the oxygen was at all extensive, the gas works or steel works at which it was employed would have plant erected expressly for its manufacture, and then no compressive storing would be required. The introduction of oxygen into metallurgical processes had a great future before it, and at the present time a number of very important experiments were being carried on with regard more especially to the reduction of the refractory ores. It had been stated that difference of pressure was the key to the success of the process; but he reminded the members that there was nothing extraordinary in the fact that at different pressures different chemical operations took place. When the plant was first erected, the peroxidation was conducted at a dull red heat and the deoxidation at a bright red heat, both at the same atmospheric pressure. It was afterwards found that the same effects could be obtained, but far more economically, if the temperature at which the two operations were conducted was kept constant at a little below the mean of the two, and if the pressure was increased for the first operation and decreased for the second. Theoretically, 1 lb. of baryta would absorb and give off again $1\frac{1}{2}$ cubic feet of oxygen. With the old process, only about 0.6 or 0.7 cubic feet could be obtained practically; and even this occupied three hours. With the new process, although the same yield of oxygen was obtained, the cycle of operations only took 15 minutes; so that the new process was in the end much more economical. With regard to the industrial uses of oxygen, the purification of coal gas was a prominent feature among them. It was being tried at the Ramsgate Gas Works; and it was hoped that Mr. Valon, the Engineer of those works, would have been able to attend the meeting to speak on the subject. But he was unfortunately prevented from doing so on account of an attack of influenza which had confined him to his room. Dr. Thorne then described the plant in use at Ramsgate and explained the process of purification by oxide of iron. He stated that in carrying this out, a small quantity of air was sometimes mixed with the gas before it entered the purifiers, so as to make the process continuous so long as the oxide retained its purifying property. This, however, had the effect of detracting somewhat from the illuminating property of the gas, due to the nitrogen in the air admitted to revivify the oxide. It was found that by using a corresponding quantity of pure oxygen in place of air, not only was the revivification more effectually carried on, but that the loss of luminosity resulting from the mixture of air, gave place to a slight increase of lighting power. A further discovery was made that the oxygen could be employed with the lime process of purification, and the use of oxide done away with; for, if oxygen were employed in the

same way, the sulphur compounds could be removed by the lime process, and render auxiliary oxide purifiers unnecessary. Mr. Valon had stated that the total sulphur in purified gas treated in this way did not exceed 8 grains per 100 cubic feet. The quantity of oxygen passing over into the gas must be small, and then the illuminating power was increased; but if any considerable excess of oxygen passed, the lighting power was decreased. The proportion of oxygen found to give the best results had been stated by Mr. Valon to be 0.10 per cent. of the volume of the gas for every 100 grains of sulphur per 100 cubic feet of crude gas. Under these conditions, the sulphur remained fixed in the lime (partly as free sulphur), and did not move forward when the lime became saturated with carbonic acid, as was the case under ordinary conditions. The life of the lime was thus nearly doubled. A most important feature, so far as the public were concerned, was that the lime, when at last it became spent, was an almost odorless and dry substance. The advantage of this in a pleasure or health resort such as Ramsgate was, as Mr. Valon pointed out, very great. Having referred to some of the other commercial uses of oxygen, Dr. Thorne concluded by remarking that the industry was at present in its infancy; but he believed that in the future these uses would be found to multiply almost indefinitely. Sir James Douglass said he was more especially interested in the production of oxygen with the view to its application to the intensifying of light. Experiments had been made at the suggestion of Mr. Goldsworthy Gurney, who had offered to make a trial at Oxford Ness light. With the same sectional area, the intensity of the light had been increased $2\frac{1}{2}$ times. This was very satisfactory; but the application was not successful commercially, as the oxygen was too dear, and it was found better to pay for more oil than the oxygen. In replying at the close of the discussion, Mr. Murray stated that the price of oxygen was 2s. per 1,000 cubic feet when made and used at one place—for instance, in the case of a gas works, where special plant was erected and the oxygen used as it was made. Compressing the gas doubled the price; but in any case the figures varied with the conditions under which the oxygen was made.

Fire Danger from Outside Electric Currents.

The Boston Manufacturers' Mutual Fire Insurance Company have published the following circular:

Electric light was first introduced in a very few risks insured by this Company before the year 1881; in that year, and in the first six months of 1882, it was adopted in a very considerable measure. In this period of its early introduction, prior to April 1, 1882, we received notice of 23 fires which had been set by the electric current in only 61 mills which had then been equipped. No claim for loss was made on any of these fires, but they disclosed conditions which were very alarming to us. An immediate investigation was made, under the direction of Mr. C. J. H. Woodbury, and certain rules were adopted for putting up the apparatus, insulating the wires, and guarding against the dangers disclosed in these 23 fires. These rules were immediately submitted to all the electric light companies or manufacturers of electric lighting apparatus who had any standing in the community, and were at once adopted by them, as well as by all insurance companies. They have not been changed since that date except so far as new inventions have called for modifications.

Since April 1, 1882—a period of nearly eight years—we have received no notice of any fire which could be attributed to electricity in any risk insured by this Company, and of course no claim has been made upon us for a loss which could be attributed to this cause. Our experience, therefore, justifies the conclusion to which we came after the first two years of electric lighting—that under proper safeguards it is the safest method of lighting that can be introduced. Electricity has also been applied in some of the works insured by us as a motive power, and electricity is now applied to lighting or motive power in over 600 risks which are insured by the factory mutual companies.

Attention, however, has lately been called to the danger of wild currents of electricity generated on the wires which may be in use for lighting, for power, and for railway service in many cities. There appears to be very little doubt that the recent destructive fire in Boston originated in the diversion of a high-tension current of electricity from its own wire to an electric-clock wire, on which it was carried to the building in which the fire originated. There appears to be little doubt that this conflagration may be attributed to the lack of precaution in guarding against an outside current of electricity. Such currents may be carried from their proper wires to other points in all cities and towns in which electric light or power is widely distributed on the public streets or over private buildings.

In order to guard against this hazard, the owners and managers of mills and works insured are advised to establish the following rules for the protection of their premises. These rules, after having been drawn by us, have been submitted to experts in various branches of electric science who are of the highest authority. The forms have been modified by them, again considered on our own part, and are believed to be suitable for what may be called an emergency:

1. No foreign wires of any kind shall be attached to buildings insured by this company for the purpose of carrying electric currents across the yard to any point.

2. All electric wires which may be required by the insured shall enter the premises at one point near the headquarters of the night watchman, where they can be kept under supervision; each of the said wires shall be guarded by a protector against strong currents operating by opening the circuit, and by a lightning arrester.

3. Such protectors against strong currents shall be located in a dry, accessible place inside the building, and as near the point of entrance of wire as possible, and shall be without ground connection; such protectors shall be mounted on non-combustible and insulated supports, which shall be provided with a receptacle for the burning or melted parts of such apparatus.

4. The lightning arresters on all wires must be placed between the protector against strong currents and the electrical portion of the apparatus within the building to which such wires are connected. No ground wires for such lightning arrester shall be attached to gas pipes within the premises of the insured.

5. All electric wires which may enter the premises of the insured must be insulated, between the line wire on the insulator attached to the buildings outside and the protecting device within, with the best quality of waterproof insulation. Moreover, such wires must enter at a distance of not less than three (3) inches from any other wire or any conducting material.

6. If any wires carrying high tension or strong currents are to be carried over or under other wires on the property of the insured, they shall be attached to poles so near to each other, with one wire so far above the other, that if a break should occur the pendant wire between these poles may not be long enough to come in contact with the wire below; or, if not carried on poles, these wires shall be so placed or protected with guard wires as to render a contact between different wires impossible.

7. If the high and low tension systems are in use in the same yard, even when developed within the works, the wires must be kept separate; and so wide apart that no contact or cross arc can be made.

Thoughts on Electric Units.

A writer in *Electrical Industries* says that in mechanical work we use quite a variety of units for measurement, and these units are quite well understood by most intelligent mechanics. Electrical measurements are mechanical, and the units adopted are directly related to the mechanical units with which we are familiar. The variations are in sizes of the units and their names. The reasons for adopting new units for electric work are similar to those which induces us to measure coal by the ton, butter by the pound, gold by the pennyweight, diamonds by the carat. We understand that the carat is a certain small part of a ton, but we do not care enough about this relationship to learn what part of a ton a carat is. The human eye has a better idea of the "fitness of things" than to measure diamonds by the same units we do coal. Therefore when scientific men were called upon to establish units for electric measurements, they sought such sizes as the force demanded, and then worked to establish accurately some standards to represent the units adopted. As these units were new they required new names, and what better course could have been adopted than to apply the names of those men who had taught the world so much of electricity as to make a need for these new units of measurement?

An electrician knows that his units are certain small parts of the common mechanical units, but he doesn't think of this relationship, except in those calculations, involving horse power parlance, any more than the diamond dealer thinks of the relation between the carat and the ton. The units mostly in use are the ohm, the volt and the ampere.

We know that any conductor offers resistance to the passage of electricity, just as we know that pipes offer resistance to the passage of water, and a unit was established for measuring this resistance. It was called an ohm, in honor of the German mathematician who originated the simple formula so much used by electricians.

A unit was established to measure the force which "pushes" elec-

tricity through conductors. It is called a volt in honor of Volta, the great Italian electrician. We have two units for expressing the force which pushes water forward, used according to circumstances. If the water is flowing through pipe systems like city water works we use the "pound" to measure the pressure, but if flowing down streams, as used for water power, we use the "foot of head" as the unit.

A unit of quantity was also established, and was called an ampere in honor of a French electrician. There are many other units in use by electricians, but the three mentioned are those most in use, and a full understanding of these is of vast importance to the mechanic. When the uses of these units are well understood it then becomes easy to appreciate the others that have been adopted, but are much less frequently used.

These three units are directly related to one another. The ampere, for instance, is the quantity of electricity which would be forced through a conductor which had a resistance of one ohm by an electric pressure of one volt. To know the work to be done by an electric current we must know both the force and the quantity, which is the same as we require in water power calculations. To say, for instance, that 1,000,000 gallons of water pass a certain place in one day would not convey any idea of the power to be obtained therefrom. The hydraulic engineer must know the number of feet fall that he could obtain for this water. Tell this engineer that you have 1,000,000 gallons per day with a drop of 20 feet, and he could very soon tell you the horse power it would give. So also with electricity; to say that we have 10 amperes would give the electrician no idea of the work that could be done by the current. He must know the force behind it. If, however, you say that you have 19 amperes and a force of 100 volts, he could very soon calculate the amount of horse power obtainable, and he could also tell what could be accomplished with this current in the various ways in which it is used.

The ampere is in reality the measurement of the rate of flow, so to speak, of the electric current, and it does not really give an idea of the quantity passing, because for this we need also to specify the time. Perhaps the best comparison is that of a trotting horse. To say that a horse passes us at a 2:40 pace would give us no idea how far he travels, but to say that he travels at a 2:40 pace for 2 minutes and 40 seconds would give us the idea that he had traveled just one mile. Using the second as a unit of time, then if we have one ampere for 1 second we have in reality a unit of quantity, and electricians have called this coulomb. This term has not come into general use, however, and another unit of quantity has been adopted in practical work. In this case the hour is used for the unit of time, and to express this unit we simply connect the two terms by a hyphen, viz., ampere-hour, and this is the unit used for most electric meters. Unfortunately this unit conveys no idea of the work that can be done by the current. For instance, one ampere hour of electricity with pressure of 50 volts, would only be worth one-half as much as one ampere-hour with 100 volts, and if an electric light company furnishing electricity with a pressure of 50 volts should charge the same price per ampere-hour as another company supplying electricity at 100 volts, the former would be receiving twice the rental of the latter. This difficulty has given rise to the practice of registering the work in lamp hours when used for lighting, and the most satisfactory meters to the public are those which indicate the work in this way. In these cases the 16 candle power lamp is used for the standard.

There are two methods of distributing electricity in practical work, one in which the current is kept constant and the force is varied according to the amount of work to be done; the other in which the force is kept constant and the quantity is varied in proportion to the work done. Suppose we had at the top of a hill a supply of water which we wish to use for power, and suppose that on one side of this hill we could descend into a valley in the depth of 100 feet, and on the other side we could only descend 10 feet, and suppose, furthermore, that we wished to operate 10 water wheels from this water power. If we put these 10 wheels side by side and connect them by a pipe large enough to supply them all, the pressure of the water would remain constant and the quantity flowing would depend upon the number of water wheels working; or, in other words, upon the amount of work done. On the other hand, supposing we put these wheels on the other side of the hill, one wheel below the other, 10 feet apart, and connect them with a pipe one after the other. To make this comparison complete it must be considered that each wheel is on a shelf or terrace in so far as the pipe is not in a straight line up and down the hill, and because each wheel is supposed to require a head of 10 feet only. Now, in this case the quantity of water passing remains constant, whereas the pressure or total drop can be considered as practically proportional to the number of wheels working. To operate all 10 wheels on this system requires a total fall of 100 feet,

and the same water works all the wheels; whereas, to work the 10 wheels by the other system requires a fall of only 10 feet, but each wheel takes its own separate supply of water. Although this comparison is a little difficult, it is essentially the same as the two methods of distributing power by electricity. If, for instance, we have 10 lamps, each of which requires a current of 10 amperes in quantity with a pressure of 10 volts, and we connect these lamps one after the other, then the same current of 10 amperes would work all the lamps, but the force would be 10 times 10 volts, or 100 volts, whereas if we connect these lamps side by side, then each would require its own supply of electricity, the same pressure would work them all, but it would require 10 times as much electricity to supply them.

ITEMS OF INTEREST FROM VARIOUS LOCALITIES.

A CORRESPONDENT at Freeport, Ills., writes: "Those who suppose that Freeport is sleeping are very much mistaken, in fact Freeport is wideawake. Especially so is this the case in the instance of our Freeport Gas Light and Coke Company, whose proprietor (Mr. Farwell) has decided to install a water gas plant, probably with a view to hastening the time for the distribution here of a fuel gas. A new gasholder will be put up this spring. A day or so ago Supt. Runner informed me that the Company had rented the corner storeroom in the building of the Y. M. C. A., which is to be fitted up as an office and show room. Mr. Farwell, aided by Supt. Runner, will here keep an assortment of burners, globes and electric light fixtures, and last—and most important of all—a good collection of cooking and heating stoves. Mr. Farwell is determined that the housekeepers of Freeport are to have ample opportunity for becoming conversant with the value of *illuminating gas* as a fuel for domestic purposes, and it may be taken for granted that he will popularize its use in this direction by selling it at a low figure.—T. T."

THE Augusta (Me.) Electric Light Company has reduced the rate for each 16-candle power incandescent light supplied to 75 cents per month. The former price was 93 cents.

AT a recent meeting of the Frostburg (Md.) Gas Light Company, Messrs. B. Stone, Lloyd Lowndes, A. E. Hitchais, F. C. Beal and Jas. Keene were appointed to make the necessary arrangements for the erection of an electric light plant to be operated in connection with the gas plant. We understand that provision will be made for an incandescent plant equal to the requirements of 750 lamps of 16-candle power each, and that the capacity of the arc system will be rated to 50 lamps of 2,000-candle power.

WE understand that the proprietors of the Stoughton (Mass.) Light, Heat and Power Company have decided to make a 12½ per cent. reduction in gas rates.

THE electric light plant at Huntingdon, Pa., which is operated as an adjunct to the local gas works, was put in service about a fortnight ago. A correspondent at Tyrone, Pa., sends us the following particulars concerning it: "The building containing the plant is a one-story brick structure located at the corner of Second and Allegheny streets, nearly opposite the Pennsylvania Railroad depot, and adjoins the gas works. The boiler room, which is at the eastern end of the house, contains two boilers, each of 70-horse power capacity. The dynamos are located in the western end of the house, are two in number, and are operated by the improved Ball engines (two in number) of 80-horse and 60-horse power, respectively. The former will operate the dynamos for supplying commercial incandescent lights, while the other will drive the machine that is to furnish the arc current for lighting the streets. The Thomson-Houston system was chosen. The plant cost about \$25,000, and is complete in every detail of modern practice. Mr. B. F. Africa is Superintendent, and Mr. Chas. E. Bates will have charge of the works. Both are competent young men.—C. H. D."

THE appointment of Mr. Samuel J. Fowler, of Westfield, Mass., to the Superintendency of the Springfield (Mass.) Gas Company has been followed by the naming of Mr. William T. Thayer to the position of Superintendent of the Westfield Gas and Electric Light Company. We understand, however, that Mr. Fowler will continue to act as Treasurer and General Manager of the last named corporation.

THE Selectmen of New Brunswick, Me., have been authorized to enter into a contract with the New Brunswick Gas Light Company for the lighting by gas of the public buildings of the town, and also such streets as are not lighted by electricity.

THE new holder on the 26th Ward works of the Philadelphia municipal gas plant was formally inspected by Councils and Gen. Wagner on the 21st inst.

A DIVIDEND of 1 per cent. on the capital stock of the Chicago Gas Trust Company has been declared. It is made payable on and after next Friday. The transfer books remain closed from March 15th to April 25th. The annual meeting of the Trust will be held on the 24th prox., and one of the important matters to be considered thereat will be a proposition to change the name of the corporation. This means, of course, that measures have been taken to re-adjust the affairs of the Trust.

IN the meantime, we might add that the Trust has given notice that it will, until further notice, through separate meters, furnish a supply of gas for fuel purposes, in quantities desired, at the rate of \$1.25 per 1,000 cubic feet, with 25 cents per 1,000 off for prompt payment.

THE buildings of the electric lighting annex of the Faribault (Minn.) Gas and Electric Light Company were destroyed by fire on the evening of the 13th inst. The total loss was \$9,075, apportioned as follows: Buildings, \$1,800; apparatus, \$7,275. The rather astonishing cause given for the conflagration is that a pile of wood which was placed *too close to the furnaces* took fire. Wood under those circumstances can usually be counted on to do its duty. But where was the engineer?

MR. ROBERT F. FITZ, who can travel incog. with ease, grace and dignity, has been appointed Superintendent of the Elgin (American) Gas Company, of Illinois. Mr. H. S. Whipple, formerly Superintendent at Elgin, goes to Rockford (Ills.) to take charge as agent there of the American Company's latest purchase. We congratulate Messrs. Whipple and Fitz on their promotions, and the American Company also on its good fortune in having such attaches.

A CORRESPONDENT, writing from San Francisco, Cal., under date of March 11th, forwards the following: "The City Council, on March 5th, granted to George W. King, of Los Angeles, Cal.—the right has been properly signed by the Mayor, and is therefore binding—and his assigns and legal representatives, the right to lay gas mains in that city. The conditions are: The life of the right is 50 years, the Company is not to charge over \$1.50 per 1,000 cubic feet to the city buildings (to include schools, engine and police stations, etc.), nor is any higher rate to be charged to private consumers. King is to file a bond, in \$20,000, for the proper replacing of the street pavements, is to lay 10 miles of pipe (distributing mains) within 1 year, and is to pay 2 per cent. of the *gross receipts* each year to the city, the payments to be made at the end of each 6 months. I have but one copy of the ordinance, else I would send you the thing complete. Mr. King was connected in some manner with the gas companies of your city, and claims to have been one of the first to introduce water gas there. He is in control of capital, and I believe he means business. I will send on word if there is anything new in the developments. The price of gas was reduced in Los Angeles, on March 1st, from \$2.25 to \$2 per 1,000; but the people seem to have been spoiled there because of the late gas war in that city, when gas sold for a time at as low as \$1 per 1,000.—RETORT."

THE following, respecting the fuel gas supply of the Louisville (Ky.) Gas Company, will be read with interest: The mains and plant of the absorbed Citizens Gas Company are employed on the work, and the streets on which the fuel gas supply may be obtained are the following: 7th, from Ormsby avenue to Chestnut; 6th, from Broadway to Main; 4th, from Broadway to Main; 2d, from Broadway to Main; Broadway, south side, from 4th to 7th; Broadway, north side, from 2d to 6th; Chestnut, from Brook to 10th; Walnut, from 3d to 6th; Jefferson, from 1st to 7th; Market, from Jackson to 12th; Main, south side, from 1st to 14th; Madison from Brook to Preston; Preston, from Madison to Market; 12th, from Main to Chestnut. The price to consumers on these streets will be 50 cents per 1,000 cubic feet, and the Company has also reduced the price of gas (of the illuminating sort) to parties not in the fuel gas district proper for purposes other than illumination to 75 cents per 1,000 cubic feet—a separate meter to be used. Therefore does it seem that Engineer Barret is to be credited with being the first in this country to have practically shown the way to the realization of the full benefit of a fuel gas that is bound to succeed—that is, the supply of a rich gas at a reasonable figure—indeed, at a low figure; for his illuminating fuel gas at 75 cents per 1,000 is bound to be a cheaper and better article than the non-carbureted fuel gas at 50 cents per 1,000. President Morris says that the Company will be able to furnish all the fuel gas needed, but will not make any extension of the fuel

gas mains until the demand justified it. The Gas Company has fuel gas in the district of the Kentucky Rock Gas Company, but does not now expect any consumers in such district, as the price of natural gas, with the discount off, is but 22½ cents per 1,000 cubic feet, while the artificial article is to be charged for at the rate of 45 cents per 1,000 with the discount off.

WE understand that Mr. Walter Woolcott, the urbane and clever Secretary of the Kansas City (Mo.) Gas Light and Coke Company, is now in the East, with a view to inspecting the various processes under which fuel gas is manufactured. He will visit the following places: Chicago, Ills., Jackson (Mich.), Cleveland, Akron, Pittsburgh, Pa., Jersey City, Louisville, Ky., and Tacony, Pa.

THE bill filed by F. M. Charlton against the Chicago Gas Trust Company to wind up its affairs and for the appointment of a Receiver was dismissed before Judge Collins, and a new petition or suit was filed. The new proceedings state that the Trust is about to pay to its stockholders the sum of \$250,000 in dividends, and complainant avers that if the Trust erected gas works, as the Supreme Court says it should, it could not pay the dividend just declared. In addition to the prayer in the first complaint Mr. Charlton asked that the payment of the dividend be enjoined.

AMONG new incorporations we note that of the Leavenworth (Kas.) Electric Light Company. The purpose of the organization is to supply light and heat by the use of gas, electricity, steam or hot air. The capital is put at \$100,000, and the Directors are: Messrs. Edward Carroll, McCown Hunt, Paul E. Harms, John Gimper and E. Henning.

MR. J. F. SCRIVER, Secretary of the Montreal (Can.) Gas Company, recently had a novel experience, as may be gleaned from the following bit of history. Edward Holloway, of 210 Peel street, had the worthy Secretary up in a local police court on a charge of assault. The alleged assault took place in the office of the Gas Company, to which premises Holloway had repaired for the purpose of asking for further grace in the matter of the payment of an overdue gas bill. In the course of the negotiations some exciting language was indulged in, and at last Mr. Scriver ordered Holloway to leave the room. On the refusal of the latter to obey the order, Mr. Scriver ejected him. The action for assault followed, but on hearing the evidence the Judge dismissed the suit with costs, holding that plaintiff should have left the premises when requested to do so.

ONE of the best arranged and most capably managed electric light plants within the borders of the State of Georgia is that owned by the Athens Gas and Electric Light Company; and it ought to be a good one, for \$50,000 was expended in its construction and equipment. It might also be said that the gas works are modern and complete. The electric annex contains two steel boilers of 70 horse power each, and two engines (one of 70-horse and one of 50 horse), which operate one 50-light arc machine, and one 650 light incandescent dynamo. The apparatus was furnished by the Thomson-Houston Company, and it is handsome and complete. Forty arcs are now in circuit, and the Company has application for 300 incandescent lamps, which it is now arranging to supply. Dr. J. A. Hunnicut, President of the Company, has great faith in its future.

THE Board of Public Works, Duluth, Minn., have extended the contract for public lighting, for a period of 3 years, with the Duluth Gas and Water Company.

WHEELING, West Va., is very much excited over charges brought against Oscar Seeley, Trustee of the City Gas Works, that three years ago he appropriated over \$1,000 worth of materials to his own use. Ex-superintendent Darral is said to have made the accusation.

SOME time ago we noted that the gas works at Reading, Pa., operated by the Reading Railroad Company, had been seriously damaged by an explosion. The Company, as a result of this happening, has decided not to rebuild the works, and to abandon the use of gas altogether. In the meantime the electric plant will be enlarged sufficiently to furnish all the light needed in depots, yards and shops.

THE lighting situation at Los Angeles, Cal., has been further simplified in the purchase by the Los Angeles Lighting Company (which is a consolidation of the Los Angeles Gas Company and the Lowe Gas and Electric Company) of the Los Angeles Electric Light Company. President Cline, of the Gas Company, has been chosen President of the newly-acquired corporation.

THE Methuen (Mass.) Gas Light Company has been incorporated with a capital of \$25,000. Its officers are: President, James F. Wall; Treasurer, Granville Parks. The stated objects are: "The manufacture and sale of illuminating and fuel gas and electricity for light, heat and power." It is presumed that this Company means business; for it will be remembered that a similar venture proposed there some time ago was never brought off.

THE officers of the Troy (N. Y.) Gas Company say that the public may rest assured that the Company will be ready to fulfil its contract with the city within the time specified—90 days from the date of contract—for the public lighting by electricity.

IN the matter of the failure of the Artificial Gas Company, of Greenville, Darke county, O., briefly alluded to in our last issue, we have the following further advices, by way of Dayton, Ohio: "One of the worst failures ever reported in Darke county is that which occurred about a fortnight ago in Greenville. The Artificial Gas Company, with its President and Secretary (John and Elijah Devor) are heavily involved. The matter was brought to a head by the filing of a suit by Mr. R. R. Dickey, of this city, who is well known to the fraternity of the West from his connection with the Dayton Company, who asked that the Greenville Artificial Gas Company be declared insolvent, and that a receiver for its affairs be appointed. Shortly thereafter John Devor made a voluntary assignment, and this act was duplicated immediately by Elijah Devor, both acting as individuals, the assignees being James A. Reis and Frank M. Eidson, respectively. These acts were followed later by the assignment of the Devor Gas Company as a corporation, Reis and Eidson being again named as assignees. The liabilities of the Company are put at \$50,000, and the assets are considerably under this figure. The liabilities include \$14,000 bonded indebtedness, and this sum is divided in the following manner: R. R. Dickey, of Dayton, \$4,000; Citizens National Bank, of Urbana, \$4,000; Second National, of Greenville, \$6,000. The bonds, however, are amply secured. The personal liabilities of the Devors are estimated at \$56,000, with perhaps assets of \$30,000."

IN our last we made note of an application to the authorities of Salt Lake City, by one Judge French, for an opposition charter. The Judge has thus unbosomed himself in respect to the project: "I have all the capital behind me necessary to carry out the plan and make it a success. I am somewhat familiar with the gas business now, being interested in two Eastern companies. This city needs first class gas works, such as we shall build if we are given the franchise, and I know it would be a good investment." Yes, Judge, it would, and it would further give you an excellent opportunity to harras the existing gas company, and perhaps to give you a chance at its treasury. Come to think of it, we were always under the impression that Salt Lake City had a pretty good gas works, and that its business was handled in a liberal and progressive fashion. In fact, we are still under that impression. Further, the Judge's plan may yet "gang aft," and we certainly hope they shall.

THE Woonsocket (R. I.) Gas Company is installing a new station meter.

THE Allegheny Heating Company, of Allegheny, Pa., has been awarded the contract for supplying natural gas to the public buildings in that city. The rate agreed on is \$25,000 per annum.

THE rates on cast iron pipe are not likely to be advanced this season, judging from the tenders made by several manufacturers in the competition for supplying pipe under contract to the Water Committee of Allegheny City. The successful bidders made the following propositions: 4-inch pipe, \$26.40 per ton; 6-inch, \$24.80; 8-inch, \$24.80; branches, 2½ cents per pound; sleeves, 2½ cents per pound.

MR. WILLIAM ST. JOHN, General Agent of the gas department of the Safety Car Heating and Lighting Company, of New York, who are the proprietors for the Pintsch compressed system of gas lighting for the States, has about convinced the Georgia Southern Railroad Company that the service of the Company would be improved were it to adopt the Pintsch system for the lighting of its cars. It is also rumored that the Pullman Company will light all its sleeping coaches by the same method.

CHARLES JENNEN, a resident of Clifton, Ohio, a village close to the city line of Cincinnati, has applied to the courts for an order setting aside the contract made by the village with the Cincinnati Gas Company for a supply of gas to the public lamps.

WE welcome to the East Mr. George C. Hicks, formerly of Chicago, Ills., who is to have personal supervision of the Boston Fire Brick Works, owned by Messrs. Fiske Coleman & Co., of 62 Congress street, that city.

THE Monroe (Mich.) Gas Light Company having completed its original term (30 years) of incorporation, has filed articles of association for another term of 30 years.

A RATHER odd suit, which is reported from Newark, N. J., is that of W. H. Ratcliffe and others, against Jennie A. Moorehouse and others. According to the papers in the case, the defendants have been attempting to invent a gas machine for the past 15 years, and some time ago they engaged a party to draw up plans for a new construction. When these were finished they awarded the construction of the machine to plaintiffs, who claim that defendants agreed to pay them at the rate of 50 cents an hour till the apparatus was completed. The latter assert that a fixed sum was agreed on. The difference is perhaps \$200.

AT last the Trustees of Cicero, Ills., have granted a franchise for the construction and operation of a gas works for that town to Messrs. Martin Maloney and W. A. Toles. The prices for gas are not to exceed \$1.40 per 1,000 cubic feet for illuminating gas and 60 cents for fuel gas, for a period of 2 years from the passage of the ordinance, and after that time, \$1.25 and 50 cents respectively. The ordinance provides that in all streets that are to be permanently improved, mains and laterals shall be laid before the improvement, and all service pipes, connections and meters to be put in at the expense of the Company. The works are to be completed and gas is to be supplied by November next, failing to do which the Company forfeits \$10,000 to the town, which sum will have to be deposited with the Town Treasurer before the ordinance is operative.

AT a special meeting of the Norfolk (Neb.) Council, Messrs. G. A. Brooks, of Bazile Mills, and certain Chicago capitalists, were granted a franchise for the construction and operation of a gas plant in Norfolk. The plant is to cost not less than \$50,000, and is to have a daily capacity of 100,000 cubic feet. Work is to be commenced on the plant within 6 months, and it is to be completed within 18 months. This place is a post village of Madison county, Neb., and is on the north branch of the Elkhorn river, at a point about 50 miles north of Columbus.

ACCORDING to a local authority, "The Superintendent of the Alexandria (Va.) city gas works reports that an expenditure of some thousands of dollars will be necessary to put the plant in complete order, if not to secure its safety. The gas works has always been the money maker of the corporation, and now that the establishment is relieved from the burden of lighting the streets, which, in the works' report of 1890 was carried on at a cost of \$6,116.79, it will pay into the city treasury about \$10,000 per annum. Heretofore the policy has been pursued of allowing the gas works to run down for want of the stitch in time that saves nine, until lately. A very large expenditure was made on the works for a new holder, etc., and now new benches are required in order that the establishment may be put in thorough order. There will, however, still remain the probable expense anticipated by Mayor Downham in his last message, when he said that 'as the gas pipes were laid many years ago they must, in the nature of things, be nearly destroyed by rust.'"

LAST Monday the shareholders of the Beverly (Mass.) Gas Light Company adopted a proposition to increase the capital stock in the sum of \$15,000, the money to be expended on plant betterment.

MANAGER LIVINGSTONE, of the St. Paul (Minn.) Gas Company, says that the proprietors will expend a large sum of money this year in extensions to the gas and electric divisions of their property. One item in the plans calls for the placing of about 16 miles of new gas mains.

RICHARD WELCH, Village Recorder of Litchfield, Minn., advertises for tenders for the construction of an electric lighting plant suitable to the needs of the district. Specifications can be examined at his office, and the competition will close at 7.30 P.M., of March 31st.

Hot Air Engine.

The principal features of the hot air engine invented, by Jerome H. Chase, of Buffalo, N. Y., are: It is provided with an ordinary and hot air chest in which is a slide valve of the usual form operated from the main shaft. Into the hot air chest leads a pipe provided with a valve and connecting with the upper end of a hot air reservoir, below which

is a heater placed above a furnace, all these parts being inclosed in a case supporting the cylinder. The reservoir is provided with a number of parallel plates extending through the bottom on to the bottom of the heater. Into the heater opens a pipe leading upward and connecting by a discharge valve with one end of an air compressor arranged alongside the cylinder and operated from the crosshead of the main piston rod. On the other end of the air compressor is a discharge valve opening into a pipe leading into the ash pit of the furnace. In the heads of the air compressor cylinder are placed inlet valves connected by pipes with a closed reservoir located inside of a cooler placed on the outer end of the main cylinder. Water flows through the cooler to cool the air.

When a fire is started in the furnace the air in the hot air reservoir is rapidly heated. When the pressure in the reservoir is sufficient the valve is turned to allow the air to pass to the hot air chest and cylinder and operate the piston in a manner precisely similar to that in the ordinary steam engine. The exhaust may be discharged into the open air or into a room to be heated. Through one pipe the compressor discharges air into the furnace to aid combustion and through the other into the heater, from whence it passes to the hot air reservoir. The arrangement of the pipes and valves is such as to permit the operator to increase or diminish the supply of cold condensed air to either the heater or furnace. It will be observed that the air in this engine is first rapidly cooled, then compressed and forced into a heater, where it is subjected to the intense heat of the furnace. Another noticeable feature is the fact that the engine is double acting.

The Quality of London Gas.

The following is abstracted from Dr. Williamson's report on the quality of the gas supplied to London during the last quarter of 1889:

Illuminating Power.—The average illuminating power, in standard sperm candles, at each of the testing stations, was as follows:

The Gas Light and Coke Company.

Jewry street, E.C.....	16.5
King street, E.C.....	16.3
Dorset Buildings, E.C.....	16.6
Ladbroke Road, W.....	16.6
Devon's Road, E.....	16.7
Carlyle Square, Chelsea, S.W.....	16.1
Camden street, N.W.....	16.3
Graham Road, E.....	16.6
Kingsland Road, E.....	16.4
Grove Gardens, Regent's Park, N. W.....	16.5
Hornsey Road, N.....	16.5
Lambeth Road, S. E.....	16.3
Millbank street, S. W. (cannel gas).....	20.8

Commercial Gas Company.

Parnell Road, E.....	16.3
Wellclose Square, E.....	16.1

South Metropolitan Gas Company.

Hill street, S. E.....	16.3
Foster Place, S. W.....	16.3
Stoney Lane, S. E.....	16.2
Lewisham Road, S. E.....	16.3
Burrage Road, S. E.....	15.8
Blackfriars Road, S. E.....	15.6

It will be seen from these results that the average illuminating power at the Blackfriars Road and Burrage Road stations of the South Metropolitan Gas Company was lower than the Parliamentary standard; and that it was above that standard at all the other testing stations. Several deficiencies in the illuminating power were reported during the past quarter—viz., at Jewry street, King street, Hornsey Road, Wellclose Square, Hill street, Stoney Lane, Lewisham Road, Blackfriars Road and Burrage Road.

Purity.—Sulphureted hydrogen was only once during the quarter reported to have been present in the gas—viz., at the Jewry street station of the Gas Light and Coke Company; and an appeal has been lodged by the Company against this return. The average amount of sulphur in other forms was considerably less than that allowed—viz., 22 grains—at all the stations, especially at Millbank street, Devon's Road, Parnell Road, and Lewisham Road, where it averaged less than half the quantity permitted. Ammonia has been present more or less frequently in the gas at all the stations, but only in slight quantities. There was no excess on any occasion during the quarter.

The Market for Gas Securities.

The city market for gas shares was in line with higher prices during the week, and Consolidated, on comparatively small transactions, moved up closely to 97, but reacted to 96½. There can be no doubt about it but that when the market for money shows signs of a settled or normal condition that Consolidated will go to par and over. Other city shares are also inquired after, and purchasers are making all the concessions in respect to quotations. Brooklyn presents nothing of interest, unless it may be noted that Metropolitan is now at par, bid. The Appeal Tax Court of Baltimore has readjusted the tax rating of the Consolidated Company, of that city, and Secretary Smoot is to be congratulated on the finesse displayed by him in the premises. It is somewhat strange to us that the "ad. of Secretary," offering to sell a controlling interest in several California gas works does not receive more attention from investors in such properties. One of the works thus offered ought to be a rare good thing. Buffalo (N. Y.) shares are being sought after.

Gas Stocks.

Quotations by Geo. W. Close, Broker and Dealer in Gas Stocks,

16 WALL ST., NEW YORK CITY.

MARCH 24.

All communications will receive particular attention.
The following quotations are based on the par value of \$100 per share.

	Capital.	Par.	Bid	Asked
Consolidated.....	\$35,430,000	100	96½	—
Central.....	500,000	50	—	—
“ Scrip.....	220,000	—	—	—
Equitable.....	4,000,000	100	117	120
“ Bonds.....	1,000,000	—	113	115
Harlem, Bonds.....	170,000	—	—	—
Metropolitan, Bonds....	658,000	—	116	118
Mutual.....	3,500,000	100	109	—
“ Bonds.....	1,500,000	—	100	102
Municipal, Bonds.....	750,000	—	—	—
Northern.....	—	50	—	—
“ Bonds.....	150,000	—	—	100
Standard Gas Co--				
Common Stock.....	5,000,000	100	—	45
Preferred.....	5,000,000	100	84	87
Yonkers.....	—	50	112	—
Richmond Co., S. I.	346,000	50	—	—
“ Bonds.....	20,000	—	—	—
Gas Co's of Brooklyn.				
Brooklyn.....	2,000,000	25	109	111
Citizens.....	1,200,000	20	68	70
“ S. F. Bonds.....	320,000	1000	102	103
Fulton Municipal.....	3,000,000	100	124	126
“ Bonds.....	300,000	—	115	—
Peoples.....	1,000,000	10	80	82
“ Bonds (5's).....	368,000	—	100	—
“ “ (6's).....	94,000	—	100	—
Metropolitan.....	1,000,000	100	100	—
Nassau.....	1,000,000	25	119	—
“ C'tfs.....	700,000	1000	100	102
Williamsburgh.....	1,000,000	50	123	125
“ Bonds... ..	1,000,000	—	108	112
Out of Town Gas Companies.				
Boston United Gas Co. —				
1st Series S.F. Trust	7,000,000	1000	93	93½
2d “ “ “	3,000,000	1000	71	72
Bay State Gas Co.--				
Stock.....	5,000,000	50	24	25
Income Bonds.....	2,000,000	1000	—	—
Buffalo Mutual, N. Y....	750,000	100	90	95
“ Bonds... ..	200,000	1000	95	100
Citizens, Newark.....	1,000,000	50	155	160
“ “ Bonds.	45,000	—	—	—

Chicago Gas Trust.....	25,000,000	100	43	—
Chicago Gas Light. & Coke Co.--				
G't'd Gold Bonds	1,650,000	1000	92½	93
Equitable Gas & Fuel Co., Chicago, Bonds	2,000,000	1000	—	102
People's Gas and Coke Co., Chicago--				
1st Mortgage.....	2,100,000	1000	—	99
2d “	2,500,000	1000	96	100
Consumers Gas Light Co., Jersey City.....	2,000,000	100	15	25
Bonds.....	600,000	1000	80	—
Cincinnati G. & C. Co..	6,000,000	100	201	203
Consumers Toronto....	1,000,000	50	190	200
Central, S. F., Cal.....			80	90
Capital, Sacramento, Cal			58	

Advertisers Index.

	Page
GAS ENGINEERS.	
Jos. R. Thomas, New York City	416
Wm. Henry White, New York City.....	419
Wm. Mooney, New York City.....	416
William Gardner, Pittsburgh, Pa.....	416
Fred. Bredel, N. Y. City.....	415
GAS WORKS APPARATUS AND CONSTRUCTION.	
James R. Floyd & Sons, New York City	419
Continental Iron Works, Greenpoint, L. I	419
Delly & Fowler, Phila., Pa.....	419
Kerr Murray Mfg. Co., Fort Wayne, Ind.....	407
Stacey Mfg. Co., Cincinnati, Ohio.....	419
Bartlett, Hayward & Co., Baltimore, Md.....	417
Morris, Tasker & Co., Limited, Phila., Pa.....	417
Davis & Farnum Mfg Co., Waltham, Mass.....	371
R. D. Wood & Co., Phila., Pa.....	418
Bouton Foundry Co., Chicago, Ills	419
Smith & Sayre Manufacturing Co., New York City.....	418
Fred. Bredel, N. Y. City.....	415
United Gas Improvement Co., Phila., Pa.....	409
National Gas Light and Fuel Co., Chicago, Ills.....	410
Simpkin & Hillyer, Richmond, Va.	403
GAS AND WATER PIPES.	
Gloucester Iron Works, Phila., Pa ..	416
Mellert Foundry and Machine Co., Reading, Pa (John Fox, Selling Agent, N. Y.).....	416
Ohio Pipe Co., Columbus, Ohio.....	416
M. J. Drummond, New York City.....	416
R. D. Wood & Co., Phila., Pa.....	418
Warren Foundry & Machine Co., New York City.....	416
Donaldson Iron Co., Emaus, Pa.....	416
Dennis Long & Company, Louisville, Ky.....	416
PROCESSES.	
National Gas Light and Fuel Co., Chicago, Ills.....	410
Bartlett, Hayward & Co., Baltimore, Md.....	417
Wm. Henry White, N. Y. City ..	419
United Gas Improvement Co., Phila., Pa.....	409
The Fuel Gas and Light Improvement Co., N. Y. City.....	404
INCLINED RETORTS.	
Laclede Fire Brick Manuf'g Co., St. Louis, Mo.....	407
GASHOLDER TANKS.	
W. C. Whyte, New York City..	410
J. P. Whittier, Brooklyn, N. Y.....	411
GASHOLDER PAINT.	
The Government Waterproof Paint Co., Boston, Mass.....	404
RETORTS AND FIREBRICK.	
J. H. Gautier & Co., Jersey City, N. J	414
B. Kreischer & Sons, New York City ..	414
Adam Weher, New York City.....	414
Laclede Fire Brick Manuf'g Co., St. Louis, Mo ..	414
Brooklyn Retort and Fire Brick Works, Brooklyn, N. Y	414
Borgner & O'Brien, Phila., Pa ..	414
James Gardner, Jr., Pittsburgh, Pa.	414
Henry Maurer & Son, New York city.....	415
Chicago Retort and Fire Brick Co., Chicago, Ills....	414
Baltimore Retort and Fire Brick Co., Baltimore.....	414
Oakhill Gas Retort and Fire Brick Co., St. Louis, Mo.	414
Boston Fire Brick Works, Boston, Mass.....	404
SCRUBBERS AND CONDENSERS.	
G. Shepard Page, New York City ..	408
R. D. Wood & Co., Phila., Pa.....	415
REGENERATIVE FURNACES.	
Bartlett, Hayward & Co., Baltimore, Md.....	417
Fred. Bredel, New York City	415
Chicago Retort and Firebrick Co., Chicago, Ills.....	414
Wm. Henry White, N. Y. City.....	419
J. H. Gautier & Co., Jersey City, N. J.....	415

GAS GOVERNORS.	
Connelly & Co., New York City.....	411
Fred. Bredel, N. Y. City.....	415
Friedrich Lux, London, England.....	403
SELF-SEALING MOUTHPIECE DOORS.	
Smith & Sayre Mfg. Co., New York City.....	418
TAR AND CARBONIC ACID EXTRACTOR.	
Geo. Shepard Page, N. Y. City.....	372
CEMENTS.	
C. L. Gerould & Co., Brooklyn, N. Y.....	414
GAS ENRICHERS.	
Standard Oil Co., Cleveland, Ohio.....	420
GAS METERS.	
John J. Griffin & Co., Phila., Pa.....	422
American Meter Co., New York and Philadelphia.....	423
The Goodwin Gas Stove and Meter Co., Philadelphia, Pa....	423
Helme & McIlhenny, Phila., Pa.....	423
D. McDonald & Co. Albany, N. Y.....	423
Nathaniel Tufts, Boston, Mass.....	422
Maryland Meter and Manufacturing Co., Baltimore, Md....	386
Bell & Jones, Philadelphia, Pa.....	422
EXHAUSTERS.	
The P. H. & F. M. Roots Co., Connersville, Ind.....	406
Smith & Sayre Manufacturing Co., New York City.....	418
Wilbraham Bros., Philadelphia, Pa.....	411
Connelly & Co., New York City.....	411
GAS COALS.	
Penn Gas Coal Co., Phila., Pa ..	421
Perkins & Co., New York City	420
Newburgh Orrel Coal Co., Baltimore Md.....	421
Despard Coal Co., Baltimore, Md	421
Chesapeake and Ohio R. R. Coal Agency, N. Y. City	421
Westmoreland Coal Company, Phila., Pa.....	421
J. & W. Wood, New York City.....	420
CANNEL COALS.	
Perkins & Co., New York City.....	420
J. & W. Wood, New York City.....	420
VALVES	
Ludlow Valve Manufacturing Co., Troy, N. Y.....	412
John McLean, New York City ..	412
Chapman Valve Manufacturing Co., Boston, Mass	412
R. D. Wood & Co., Phila., Pa.....	418
The P. H. & F. M. Roots Co., Connersville, Ind.....	406
GAS ENGINES.	
Schleicher, Schumm & Co. Phila., Pa	424
Clerk Gas Engine Co., Phila., Pa	412
Van Duzen Gas Engine Co., Cincinnati, Ohio.....	412
ENGINES AND BOILERS.	
Jarvis Engineering Co., Boston, Mass.....	411
Ball Engine Co., Erie, Pa.....	404
Westinghouse Machine Co., Pittsburgh, Pa.....	415
GAS LAMPS.	
G. Shepard Page, New York City ..	376
Weisbach Incandescent Gas Light Co., Phila., Pa.....	405
The Siemens-Lungren Company, Philadelphia, Pa.....	405
Fiske, Coleman & Company, Boston, Mass.....	404
PURIFIER SCREENS.	
John Cahot, New York City ..	412
Bartlett, Hayward & Co., Baltimore, Md.....	412
GAS STOVES.	
American Meter Co., New York and Philadelphia.....	413
The Goodwin Gas Stove and Meter Co., Phila. Pa	388
George M. Clark & Company, Chicago, Ills.....	405
D. McDonald & Co., Albany, N. Y.....	423
Maryland Meter and Manufacturing Co., Baltimore, Md....	386
Bell & Jones, Philadelphia, Pa.....	422
Chicago Gas Stove Company, Chicago, Ills	404
STREET LAMPS	
J. G. Miner, Morrisania, New York City.....	403
Bartlett Street Lamp Man'g Co., New York City	403
BURNERS	
C. A. Gefroerer, Phila., Pa.....	420
H. W. Rappleye, Philadelphia, Pa ..	368
STEAM BLOWER FOR BURNING BREESE.	
H. E. Parson, New York City.	412
PURIFYING MATERIAL.	
Connelly & Co., New York City.....	411
Friedrich Lux, London, England.....	403
Edgewater Lime Works, Edgewater, N. J.....	403
COKE CRUSHER.	
C. M. Keller, Columbus, Ind.....	421
ELECTRICAL APPARATUS.	
Wm. Henry White, N. Y. City.....	419

**WANTED,
Management of Gas Works.**

By practical gas man of many years' experience. Is master of all branches of work about a small plant—main laying, services, retort setting, gasfitting, or repairs about the works. Best of references. 771-2 Address "W," care this Journal.

**POSITION WANTED.
A Mechanical Engineer,**

Experienced in Gas Manufacture, wishes a position as Superintendent of a Gas Works. Best of references given and asked. Salary, \$1,200.

"MECHANICAL ENGINEER," care this Journal, 765-tf or Box 972, West Bay City, Mich

Position Wanted

As Superintendent or Assistant of a Gas Works,

By a man who can give the best of references. Thoroughly understands the manufacture and distribution of gas and the construction of works. Address 770-3 "M.," care this Journal.

For Sale, Cheap.

Thirty Benches of 5's, with Cast Iron Hydraulic Main, 5-inch Stand and Dip Pipes, Plugs, etc Also, Stays and Rods for Forty Benches, with Door Frames and Doors. Mouthpieces, Lids, Cotter Bars, etc. Four Iron 4-Wheel Side-Drop Retort House Coke Wagons. Four Good Coal Carts. Twelve Charging Scoops. Hoes, Rakes, and Firing Tools.

One Set Round Purifiers, 10 ft. diameter, 12-in. Seal, with Wet Center Seal.

Washers, Scrubbers, and

One Mackenzie Exhauster, 12-in. openings, 500,000 cu. ft. capacity.

Will sell whole or in part, to suit purchaser. Address

772-4 MUNICIPAL GAS CO., Albany, N. Y.

FOR SALE,

The Ironwork for Twelve Benches of 6's, viz.: Cast Iron Hydraulic Main.

7-inch Dip-Pipes, Stand-Pipes, and Bridge-Pipes, complete.

Floyd Mouthpieces and Self-Sealing Lids, 15x26 in Lids and Mouthpieces only in use over a year. Will be sold cheap.

ISAAC C. BAXTER,

772-tf

Detroit (Mich.) Gas Lt. Co

FOR SALE,

The Ironwork for 11 Benches of 5's, viz.:

Cast Iron Hydraulic Mains, 17 inch diameter, inside.

Dip Pipes, Bridge Pipes, Stand Pipes.

Mouthpieces and Lids.

Four Purifiers, 10 by 16 ft., with 10-inch Connections and dry Center Seal.

Four Purifiers, 5½ by 10 ft., with 6-inch Connections and Wet Center Seal.

Valves, 6-inch, 8-inch, and 10-inch.

DAVID MOORE, Treas. Salem Gas Lt. Co.,

770-tf

Salem, Mass.

GAS WORKS FOR SALE.

A CONTROLLING INTEREST IN SEVERAL

Interior California Coal Gas Plants,

now paying handsomely, are offered on very reasonable terms This is an exceptionally good opportunity for practical gas men of limited means, wishing to remove to a mild and healthful climate, to acquire an established and paying business. Particulars given and full investigation solicited.

SECRETARY, 123 Beale Street,

760-3 mos.

San Francisco, Cal.

FOR SALE.

A Complete Water Gas Plant.

60,000 Cu. Ft. Daily Capacity.

Fully equipped; all the latest improvements; includes Generator, Purifiers, and Holder. Can be removed to any part of the country, and set up at small cost. For further information apply to BRADFORD GAS LT. & HEATING CO., Dunkirk, N. Y.

6 PER CENT.

First Mortgage Bonds

ON GAS WORKS

SITUATED IN GROWING WESTERN TOWNS.

Principal and Interest Guaranteed.

INTEREST SEMI-ANNUALLY.

For sale by the undersigned, who will furnish all necessary information regarding them.

JOS. R. THOMAS, 42 Pine St., N. Y. City.

EDGEWATER LIME WORKS

Chas. F. McKenna, Proprietor.

SHELL LIME.

Lime by the Cargo for Gas Purification.

EDGEWATER, BERGEN CO., N. J.

Write for Testimonials and Prices.

Fuel and Its Applications.

By E. J. MILLS, D.Sc. F.R.S., and F. J. ROWAN, C.E., assisted by others, including Mr. F. P. Dewey, of the Smithsonian Inst., Wash., D. C.

7 PLATES, AND 607 OTHER ILLUSTRATIONS. ROYAL OCTAVO, PAGES xx, 802. HANDSOME CLOTH, \$7.50.

A. M. CALLENDER & CO., 42 Pine St., N. Y.

Simpkin & Hillyer

RICHMOND, VA.

MANUFACTURERS OF

Gas Works Apparatus

BENCH CASTINGS, CONDENSERS,

Scrubbers, Purifiers, Dry Center Seals,

FOUR-WAY VALVES, GAS VALVES,

SULPHATE OF AMMONIA APPARATUS,

TANKS, ENGINES, BOILERS,

PUMPS, ETC., ETC.

Plans, Specifications and Estimates furnished for new works, or alteration of old works. Correspondence solicited. Works, Newport News, Va.

Bartlett Street Lamp Mfg. Co.

MANUFACTURERS OF

Globe Lamps,

FOR

Streets, Parks, Public Buildings, Railroad Stations, etc.

LAMP POSTS

A Specialty.

Office and Salesroom,

40 & 42 COLLEGE PLACE, - - N. Y. CITY.

Gas Companies and others intending to erect Lamps and Posts will do well to communicate with us.

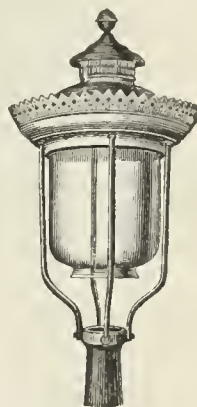
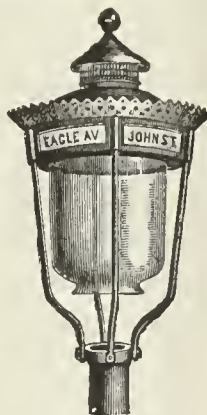

The Miner Street Lamps.

Jacob G. Miner,

No. 823 Eagle Ave., New York, N. Y.

FRIEDRICH LUX,

Ludwigshafen am Rhein and London.

Lux Mass

GAS GOVERNORS,

Gas Balance.

GAS vs. ELECTRIC LIGHT.

We would invite attention to the able and exhaustive argument of General A. Hickenlooper, President of the Cincinnati Gas Light and Coke Company, contained in a handsome pamphlet of 96 pages, entitled

"EDISON'S INCANDESCENT ELECTRIC LIGHTS FOR STREET ILLUMINATION. REPORT OF AN ARGUMENT DELIVERED BY A. HICKENLOOPER BEFORE THE COMMITTEE ON LIGHT, MUNICIPAL COUNCIL, CITY OF CINCINNATI, JULY 22, 1886."

This is a subject of special interest to all Gas Light Companies.

Prices.

25 copies..... \$7.50 100 copies..... \$22.50
50 copies..... 12.50 250 copies..... 50.00

A sample copy will be sent by mail on receipt of 50 cts.

A. M. CALLENDER, & CO., 42 PINE ST., N. Y. CITY

F. D. HARMON, PRES.

CHAS. C. ALLEN, SEC. AND TREAS.

P. W. MACKENZIE, CHIEF ENGR. & SUPT.

THE FUEL GAS AND LIGHT IMPROVEMENT CO.

OF AMERICA.

Owner of the Mackenzie Patents of Dec. 31, 1889,
For the United States, England, Russia, France, Germany, Austria, and Canada,

No. 32 Park Place, New York City.

This SYSTEM is an ABSOLUTELY NEW DEPARTURE IN THE MANUFACTURE OF FUEL AND ILLUMINATING GAS. The COST OF GAS IN THE HOLDER by our System is at least THIRTY PER CENT. LESS than that made by any other process of the day. The Gas contains neither SULPHUR nor other impurities, nor is there any resultant LAMPBLACK OR TAR RESIDUUM. The Gas is manufactured WHOLLY from LIQUID HYDROCARBONS, such as Lima, Penn. Crude, and Fuel Oils, Naphtha, etc. Neither PERISHABLE PIPES nor other RETORTS, NOR THEIR EQUIVALENTS, are used. The Gas requires NO PURIFICATION. Neither COAL, COKE, nor any other HARD CARBONS enter into the manufacture or composition of the Gas, thereby requiring LESS LABOR THAN ANY OTHER METHOD. The APPARATUS is extremely SIMPLE, SUBSTANTIAL, and DURABLE. Works under our system can be CONTINUOUS or ALTERNATING. If alternating, the Nitrogen present will be less than $4\frac{1}{2}$ per cent. If continuous, the limited amount of Nitrogen present is neutralized by Carbon. One gallon of Lima oil by our process EQUALS ALL THE COAL required for making 1,000 feet of carbureted Water Gas.

Boston Fire Brick Works Manufacturers of Gas Retorts and Settings

Under the Personal Supervision of MR. GEO. C. HICKS late of Chicago.

Fire Clay Goods of all kinds. Akron Sewer Pipe, Lime, Cement, etc. Agts. for the Arc Gas Lamp & Governing Gas Burners.

Send for Circulars and Prices to

FISKE, COLEMAN & CO., Managers, No. 62 Congress Street, Boston, Mass.

GEROULD'S

System Gas Bookkeeping.

Approved and adopted by many of the prominent Gas Engineers of the Country.

Sample Sheets and Price-List furnished free on application to

L. P. GEROULD, - - Mendota, Ill.

GREENOUGH'S

"DIGEST OF GAS LAW."

Price, \$5.00.

This is a valuable and important work, a copy of which should be in the possession of every gas company in the country, whether large or small. As a book of reference it will be found invaluable. It is the only work of the kind which has ever been published in this country, and is most complete. Handsomely bound. Orders may be sent to

A. M. CALLENDER & CO.,
42 Pine Street, N. Y.

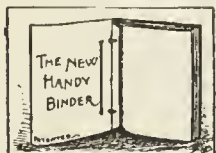

THE NEW HANDY BINDER.

This article may be described as elegant in appearance, strong, durable, and possessing many special qualities of its own. It allows the opening of the pages perfectly flat, whether one or several numbers are in the binder. Any number can be taken out and replaced without disturbing the others. The papers are not mutilated for subsequent binding in permanent form. The binder is supplied with gilt side title, and is an ornament to any desk or reading table. The JOURNAL, filed in the Handy Binder, becomes a volume of great value, always convenient for instant reference. Handy Binder, Postage paid, \$1.00.

A. M. CALLENDER & CO., 42 Pine St., N. Y.

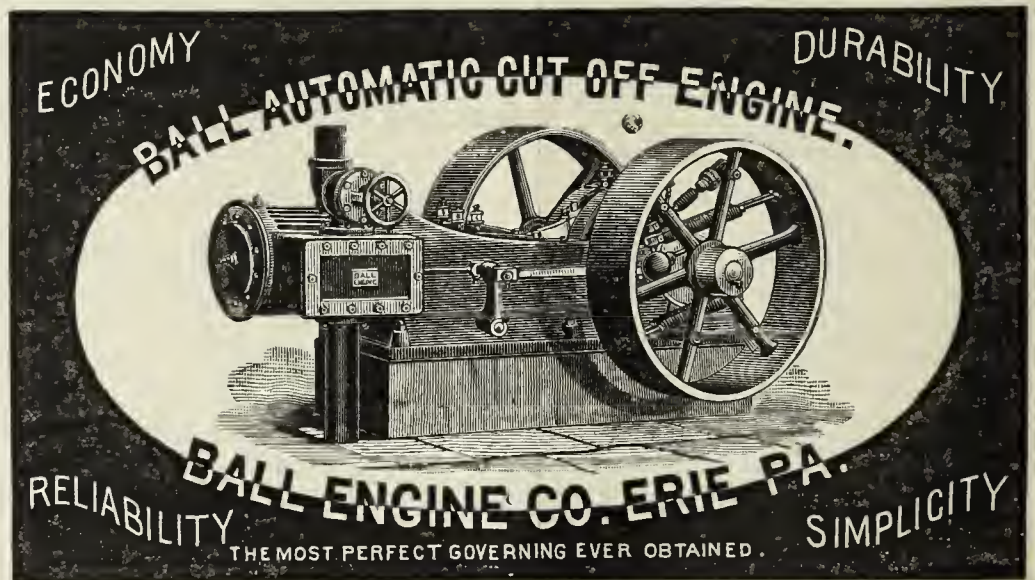

CHICAGO GAS STOVE CO.

MANUFACTURERS OF ALL KINDS OF

Gas Cooking and Heating APPLIANCES.

117-119 Lake St., CHICAGO.

Send for Catalogue.

GASHOLDER PAINT.

Use Only

THE GOVERNMENT WATERPROOF PAINT.

Proof against Ammonia, and Absolutely Waterproof. Send for Prices and Particulars.

THE GOVERNMENT WATERPROOF PAINT CO., 122 Milk Street, Boston, Mass.

The Gordon Portico Lamp.

A successful Competitor of the Arc Electric Light for lighting Store Fronts, Show Windows, Depots, Railway Sheds, etc., etc.

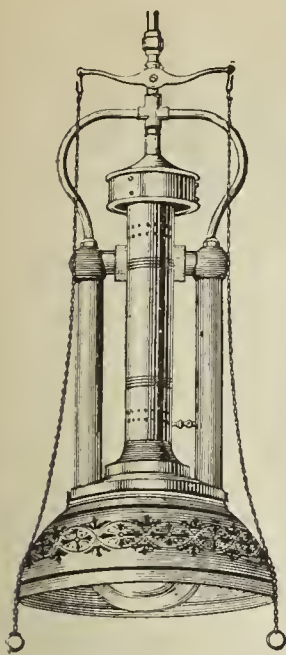

Gordon Portico Lamp.

The Gordon Street Lamp.

A Successful Competitor of the Arc Electric Light for lighting Streets, etc., etc.

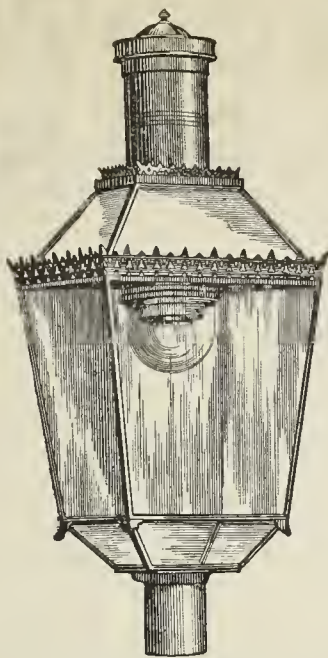

Gordon Street Lamp.

The Lungren Lamp.

A Successful Competitor of the Incandescent Electric Light for Interiors, etc. Is especially applicable for the lighting of Offices, Stores, Factories, Mills, Show Windows, Libraries, and all situations where an increased illumination is desired.

More than 25,000 Lungren Lamps are now in use. Testimonials, references, or any desired information will be cheerfully given.

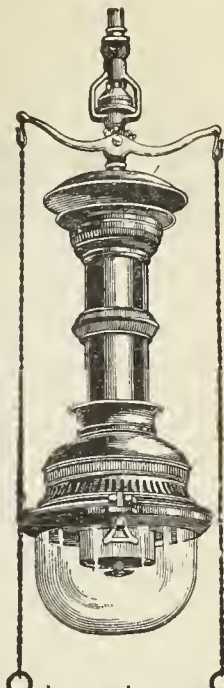

Lungren Lamp.

THE SIEMENS-LUNGREN CO., N.E. Cor. 21st St. & Washington Av., PHILADELPHIA.

WELSBACH SYSTEM OF Incandescent Gas Lighting.

OFFICE, DREXEL BUILDING, PHILA., PA.

At the Fall Session of the Board of Supervisors of Winnebago County, held at the County Court House, Oshkosh, Wis., Nov. 26, 1889, the report submitted by Mr. C. W. Cook, Chairman of the Committee on Public Buildings, recommending the use of the Welsbach Incandescent Gas Burner in the Buildings under their charge, was unanimously adopted, because of the extreme economy in the consumption of Gas and the superior character of the light obtained.

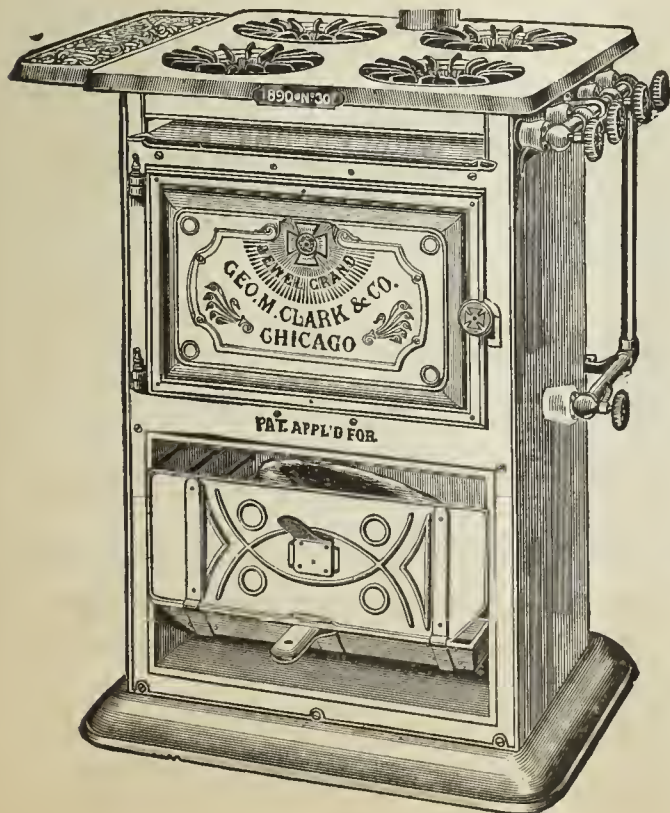

JEWEL GAS STOVES

MANUFACTURED BY

GEORGE M. CLARK & COMPANY,

Nos. 157 & 159 Superior Street, - - - Chicago, Ill.

EVERY CONCEIVABLE SIZE AND STYLE,

Ranging in Prices from \$1.50 to \$30.00.

WE USE NO GAS COCKS.

All Flames are Regulated by a Direct Needle Valve.

The JEWEL

IS THE

Only Well-Made Gas Stove on the Market.

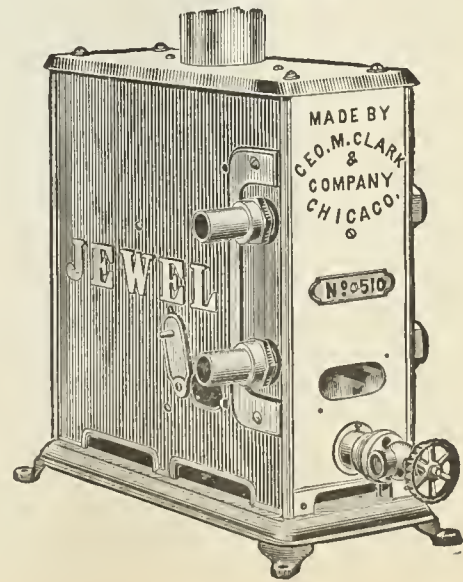

Write for our 1890 Catalogue and see for yourself.

ROOTS'

GAS AND BYE-PASS VALVES.

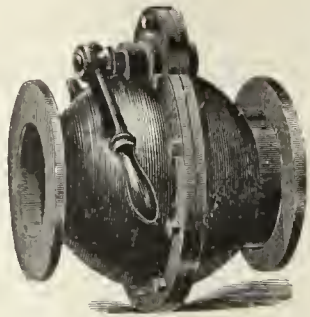

GAS VALVE

Quick Acting,
Simple,
Efficient, Durable.



BYE-PASS VALVE.

Automatic Action,
Reliable,
Simple, Durable.

Thousands now in use and giving perfect satisfaction. Write for Catalogue and Prices.

ROOTS'

NEW GAS EXHAUSTER.

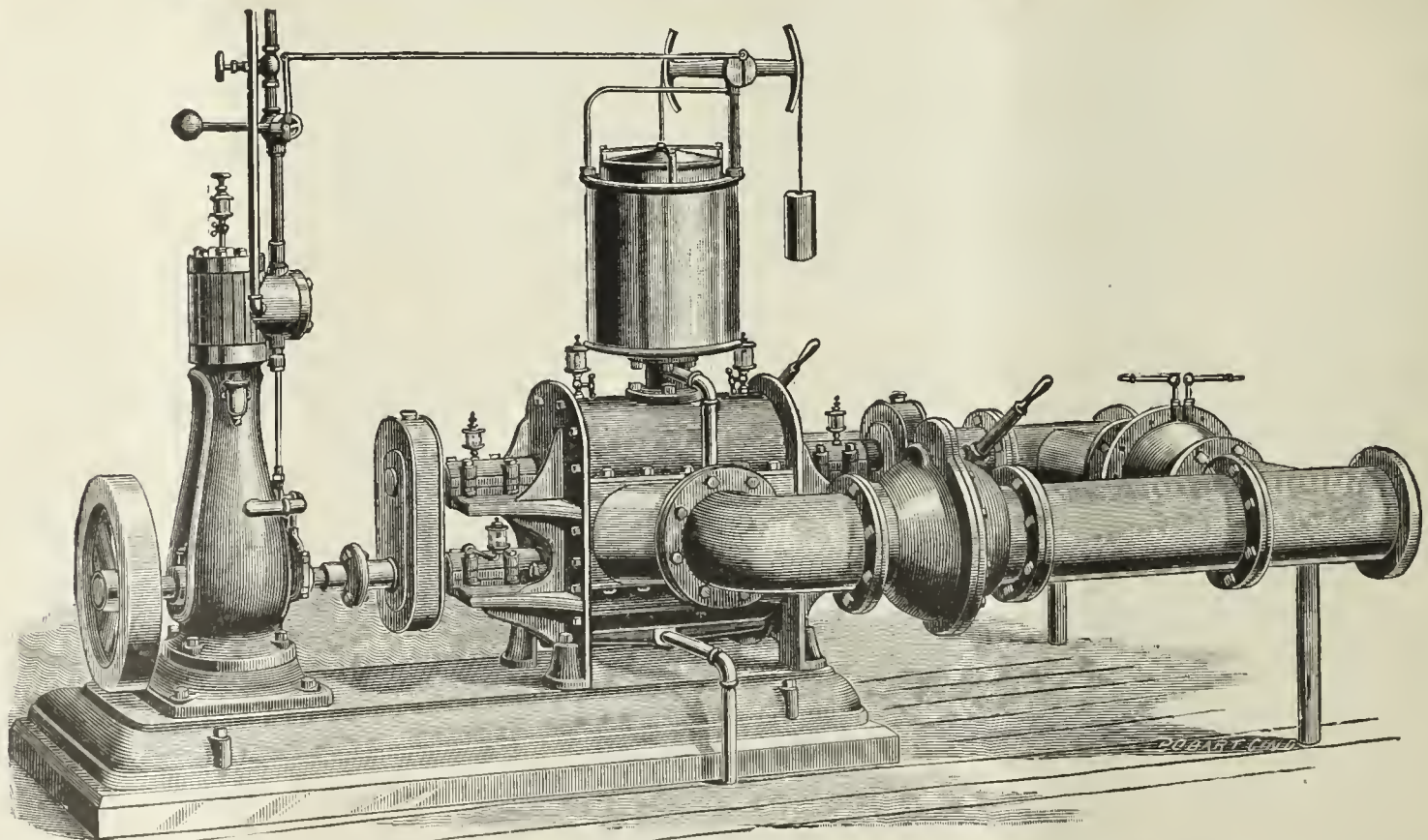

We will take pleasure in furnishing estimates on complete plants, including **GAS EXHAUSTER, ENGINE,** and **GAS GOVERNOR,** all connected, complete, on same bedplate. Also, estimates for **GAS VALVES, BYE-PASS VALVES,** and **PIPE FITTINGS,** arranged in any manner to suit the exhauster room or main connections.

All flanges of pipe and valve fittings faced off, with bolt holes drilled, all ready to go together.

S. S. TOWNSEND, General Agent, }
COOKE & CO., Selling Agents, } 22 Cortlandt St., N. Y. P. H. & F. M. ROOTS CO., Connerville, Ind.

THIS SPACE
WILL BE
Occupied Next Month by the
KERR MURRAY MFG. CO.
FORT WAYNE, IND.
**GAS WORKS
APPARATUS
AND
HOLDERS.**

LACLEDE FIRE BRICK MANUFACTURING COMPANY,

ST. LOUIS, MO.

Exclusive Agents in the United States

FOR THE

Coze System of Inclined Retorts.

IT IS THE COMING BENCH
FOR MAKING COAL GAS.

*It will Save from 50 to
60 per ct. in Labor.*

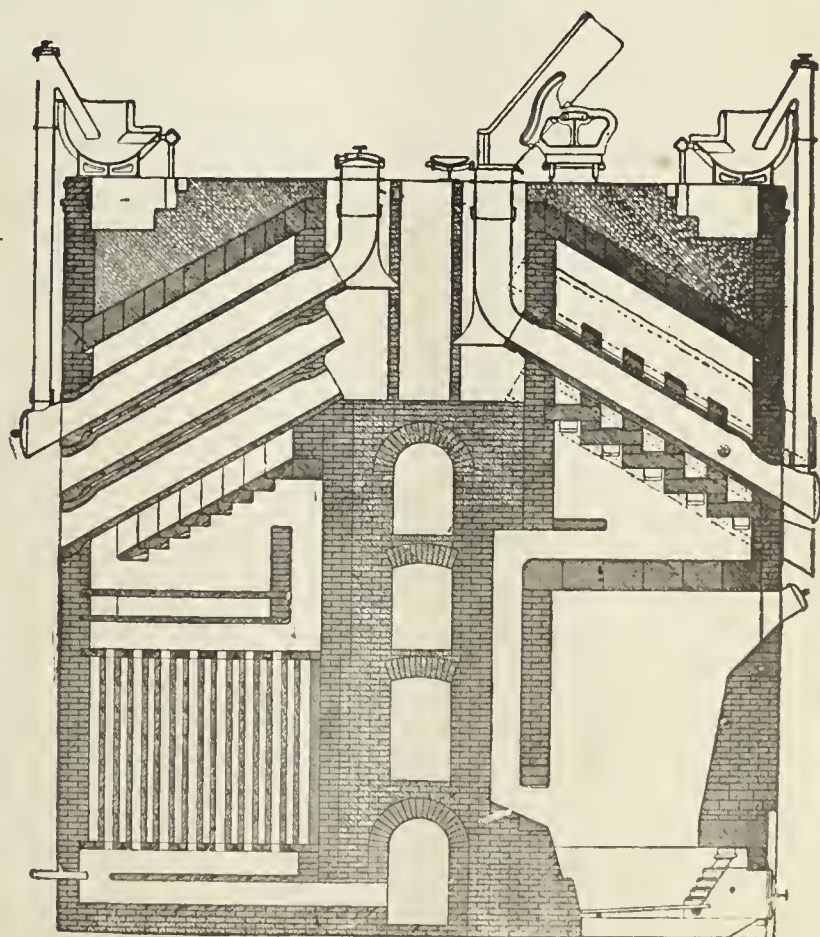
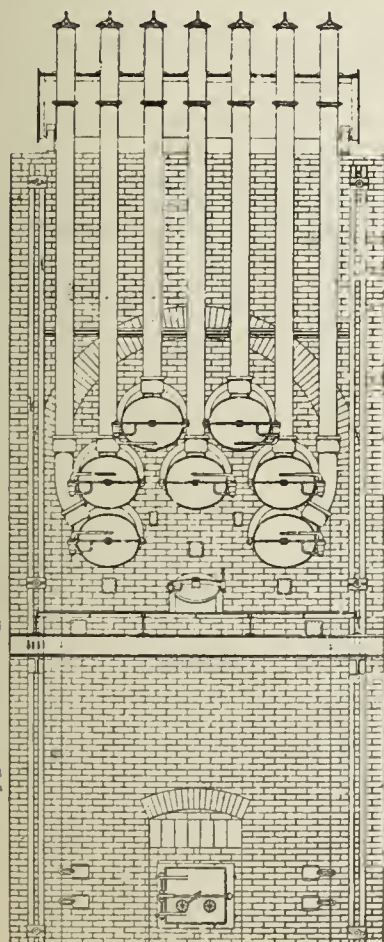

ESTIMATES AND PLANS FURNISHED BY THE

LACLEDE FIRE BRICK MFG. CO., ST. LOUIS, MO.

KIRKHAM, HULETT & CHANDLER, LIMITED.

PATENT "STANDARD" WASHER-SCRUBBERS
Erected and in course of construction at present date:

Capacity. Cubic feet per day.	Capacity. Cubic feet per day.	Capacity. Cubic feet per day.	Capacity. Cubic feet per day.
Altrincham..... 600,000	Dublin..... 3,000,000	LONDON—Continued.	Ober Schlesian..... 1,500,000
Adelaide..... 600,000	Dowlais..... 100,000	Shoreditch..... 2,500,000	Otto & Co's Coke Works..... 1,500,000
Aldershot..... 200,000	Douai..... 500,000	Paueras..... 1,500,000	Plymouth..... 2,000,000
Allegheny, U. S. A. 1,000,000	Denton..... 500,000	"..... 1,500,000	Parramatta, N. S. W..... 100,000
Ashton-under-Lyne..... 1,250,000	Derby, U.S.A. 350,000	Pimlico..... 2,000,000	Prescott..... 150,000
Amsterdam..... 1,500,000	Denver, " 500,000	Nine Elms..... 3,000,000	Providence, U.S.A. 750,000
"..... 1,500,000	"..... 1,000,000	"..... 3,000,000	"..... 750,000
Annaberg..... 200,000	Dusseldorf..... 750,000	South Metropolitan Co:—	Plaueu..... 300,000
Arcachon..... 100,000	"..... 500,000	Greenwich..... 3,000,000	"..... 300,000
Animal Charcoal Co..... 200,000	Dumfries..... 250,000	Woolwich..... 400,000	Portsmouth..... 2,500,000
Altoona, U.S.A. 350,000	Dunedin, N.Z..... 400,000	Vauxhall..... 3,000,000	"..... 2,500,000
Buxton..... 250,000	Darlington..... 1,250,000	"..... 3,000,000	Pittsburgh, U.S.A. 1,500,000
Bradford..... 1,000,000	Detroit, U.S.A. 750,000	Lea Bridge..... 300,000	Portland, " 560,000
"..... 1,250,000	Edinburgh..... 1,500,000	West Ham..... 1,500,000	Pawtucket, " 500,000
"..... 1,250,000	"..... 2,000,000	Leeds..... 2,000,000	Quebec 250,000
"..... 1,250,000	Enfield..... 300,000	"..... 3,000,000	Radcliffe..... 750,000
"..... 1,000,000	Essen..... 300,000	"..... 3,000,000	Rouen..... 250,000
"..... 1,000,000	Elbing..... 150,000	"..... 3,000,000	Rausgate..... 1,000,000
"..... 3,000,000	Falmouth..... 150,000	"..... 3,000,000	Reigate..... 200,000
Bremen..... 150,000	Frankfort..... 300,000	"..... 3,000,000	Richmond, U.S.A. 250,000
Baltimore, U.S.A. 1,000,000	Farnworth..... 400,000	"..... 3,000,000	Roxbury, " 500,000
"..... 1,000,000	Fenton..... 400,000	"..... 3,000,000	Runcorn Soap Co..... 20,000
"..... 1,000,000	Friedenshutte..... 500,000	"..... 2,000,000	Rockhampton, N. S. W..... 125,000
Balmain, N.S.W..... 125,000	Furth..... 400,000	Leominster..... 150,000	Richmond..... 1,500,000
Bishops Stortford..... 150,000	Freiburg..... 200,000	Leiden..... 50,000	Reading..... 2,000,000
Blackpool..... 400,000	Goole..... 250,000	"..... 600,000	Reichenbach..... 200,000
Brussels..... 1,250,000	Glossop..... 300,000	Liverpool..... 2,000,000	Salford..... 1,750,000
"..... 1,250,000	Guildford..... 300,000	"..... 2,000,000	"..... 1,750,000
"..... 750,000	Gloucester..... 1,250,000	"..... 2,000,000	"..... 1,750,000
"..... 1,250,000	Gera..... 300,000	"..... 2,000,000	Smethwick..... 750,000
Banbury..... 250,000	Grafton, N.S.W..... 100,000	"..... 2,000,000	Sydney, N. S. W..... 1,000,000
Birmingham..... 5,000,000	Grieg..... 300,000	"..... 3,000,000	"..... 1,000,000
Birkenhead..... 2,500,000	Georgetown, U.S.A. 250,000	Lincoln..... 1,000,000	"..... 2,500,000
Blackburn..... 1,500,000	Gluckauf..... 200,000	"..... 600,000	"..... 50,000
Bochum..... 600,000	Heywood..... 600,000	Lowell, U. S. A. 1,000,000	"..... 50,000
Burntisland..... 250,000	Hollywood..... 125,000	Louisville..... 1,500,000	Sunderland..... 1,500,000
Boston, U.S.A. 2,000,000	Huy..... 70,000	Long Eaton..... 500,000	St. Josephs, U.S.A. 250,000
Brisbane..... 1,500,000	Harrow..... 250,000	Lilie..... 900,000	Spa..... 100,000
"..... 300,000	Harrogate..... 250,000	"..... 450,000	Sevenoaks..... 300,000
Burton-on-Trent..... 1,500,000	Halstead..... 150,000	"..... 750,000	St. Petersburg..... 2,000,000
Barcelona..... 350,000	Heilbronn..... 200,000	"..... 250,000	"..... 1,500,000
Barking..... 100,000	Havana, Cuba. 750,000	"..... 250,000	St. Louis, U.S.A. 2,000,000
Baerlien & Co..... 20,000	Hastings..... 1,500,000	Luckenwalde..... 330,000	"..... 2,000,000
"..... 20,000	Huddersfield..... 300,000	Liegwitz..... 300,000	"..... 1,000,000
Bombay..... 400,000	"..... 750,000	Lincoln, U. S. A. 250,000	Laclede..... 1,000,000
Buffalo, U.S.A., Mutual 750,000	"..... 1,500,000	Lawrence..... 500,000	Silesian Coal Co..... 600,000
Citizen 500,000	Hof..... 200,000	Lynn 300,000	San Francisco, U.S.A. 2,000,000
Brookline, U.S.A. 500,000	Hampton Wick..... 500,000	Lyons..... 1,500,000	"..... 2,000,000
Bergen..... 350,000	Heckmondwicke..... 500,000	Maidstone..... 1,000,000	Sheepbridge Coal Co..... 40,000
Berlin..... 1,250,000	Haverfordwest..... 100,000	Marseilles..... 1,500,000	Stettin..... 200,000
Bournemouth..... 1,000,000	Halifax, N.S. 350,000	"..... 1,500,000	Singapore..... 300,000
Bridgeport, U.S.A. 500,000	Hamm..... 200,000	Mons..... 500,000	Sutton..... 500,000
Brunswick..... 300,000	Halle..... 400,000	Malines..... 250,000	Tonbridge..... 150,000
Beck & Co., St. Louis 100,000	Heidelberg..... 300,000	Melbourne..... 1,500,000	Tiptou..... 400,000
Barmen Rittershausen..... 600,000	Hartford, U.S.A. 1,000,000	"..... 1,500,000	Tottenham..... 1,000,000
Bexhill..... 125,000	Ilkeston..... 300,000	"..... 1,500,000	Toledo, U.S.A. 750,000
Brooklyn, U.S.A. 1,000,000	Inverness..... 250,000	"..... 1,500,000	Toronto 1,000,000
"..... 1,000,000	Ilkley..... 200,000	Manchester..... 2,500,000	Uxbridge..... 300,000
"..... Nassau 1,000,000	Ilford..... 100,000	Middleton..... 400,000	Valparaiso 500,000
Brunner, Mond & Co..... 400,000	Kingston-on-Hull..... 400,000	Manly, N. S. W..... 100,000	West Bromwich..... 1,000,000
Cheltenham..... 2,000,000	Kidderminster..... 750,000	Minneapolis, U. S. A. 750,000	Willenhall..... 250,000
Cannes..... 200,000	Kidsgrove..... 100,000	Magdeburg..... 300,000	Weston-super-Mare..... 500,000
Croydon..... 1,500,000	Konigberg..... 1,000,000	Memphis, U. S. A. 750,000	Waltham..... 150,000
Copenhagen..... 200,000	King's Lynn..... 300,000	Nottingham..... 1,250,000	Wormwood Scrubs..... 300,000
Clevedon..... 200,000	LONDON:—	"..... 2,500,000	Williamsburg, U.S.A. 600,000
Columbus, U.S.A. 500,000	The Gaslight and Coke Co.:	"..... 2,500,000	Wellington..... 150,000
Cincinnati, " 1,500,000	Beckton..... 1,250,000	"..... 2,000,000	Warwick..... 300,000
"..... 1,500,000	"..... 1,250,000	"..... 1,500,000	Wheeling, U.S.A. 500,000
Chicago 3,000,000	"..... 1,250,000	Newport, U.S.A. 430,000	Walker..... 300,000
"..... 1,000,000	"..... 1,250,000	Newmarket..... 150,000	Westgate..... 100,000
"..... 1,000,000	"..... 1,250,000	Newark, U.S.A. 680,000	Wilmington, U.S.A. 500,000
Chemnitz..... 1,000,000	"..... 1,250,000	Northfleet..... 200,000	Windsor, N. S. W..... 100,000
Crewe..... 1,250,000	"..... 2,500,000	New York, U.S.A. 2,000,000	Wolverton..... 100,000
Colonial Gas Works Co..... 100,000	"..... 2,500,000	Nice..... 600,000	Wellington, N. Z..... 250,000
Cadiz..... 300,000	Silvertown..... 1,000,000	Newcastle, N. S. W..... 200,000	Whitechurch..... 175,000
Charlottenburg..... 600,000	Bromley..... 2,000,000	Numea, "..... 100,000	Washington, U.S.A. 2,000,000
Dudley..... 750,000	"..... 1,500,000	Namur..... 250,000	Wallasey..... 750,000
Driffield..... 100,000	"..... 1,500,000	Newark..... 350,000	Weimar..... 150,000
Dukenfield..... 500,000	"..... 1,500,000	Oldbury..... 500,000	Wirzen..... 200,000
Dover..... 750,000	"..... 2,000,000	Otley..... 200,000	Worcester, U.S.A. 750,000
"..... 1,000,000	"..... 1,500,000	Oswestry..... 250,000	Yeafon..... 500,000
Deal..... 200,000	"..... 1,500,000		Yeovil..... 250,000
Derby..... 1,500,000			

SOLE AGENT FOR WESTERN HEMISPHERE,

GEO. SHEPARD PAGE, 69 WALL STREET, NEW YORK.

THE UNITED GAS IMPROVEMENT CO.

DREXEL BUILDING, PHILADELPHIA.

OFFICERS:

WILLIAM W. GIBBS, President.

EDWARD C. LEE, Sec'y and Treas.

GEORGE PHILLER, Vice-President.

ALEX. C. HUMPHREYS, Gen'l Supt.

SAM'L T. BODINE, Gen'l Manager.

WALTON CLARK, Ass't Gen'l Supt.

RANDAL MORGAN, Gen'l Counsel.

H. H. EDGERTON, Chem. and Eng'r.

DIRECTORS:

GEORGE PHILLER,

HENRY C. GIBSON,

WILLIAM G. WARDEN,

THOMAS DOLAN

WM. T. CARTER,

SAM'L T. BODINE.

BUILDERS, LESSEES AND PURCHASERS OF

✻ GAS WORKS. ✻

Orders solicited from Large Cities, Small Towns, Mills, Institutions, from all who want more Light for Less Money.

NATIONAL GAS LIGHT AND FUEL COMPANY,

No. 218 La Salle Street, Chicago.

THE SPRINGER SYSTEM

OF

Fuel and Illuminating Water Gas Works.

REFERENCES.

People's Gas Lt. & Coke Co..Chicago, Ill.
 Illinois Light, Heat & Power
 Co.....Chicago, Ill
 Elgin National Watch Co..Elgin, Ill.
 C. R. I. & P. R. R. Shops..Chicago, Ill.
 Decatur Gas Lt & Coke Co..Decatur, Ill.
 Niles Gas Light Co.....Niles, Mich.
 Newton Illuminating Co...Newton, Kansas.
 Wellington Light & Heat Co..Wellington, Kansas.
 Chippewa Falls Gas Lt. Co..Chippewa Falls, Wis.
 Elkhart Gas Lt & Coke Co..Elkhart, Ind.
 Madison City Gas Light Co.Madison, Wis.
 South Bend Gas Light Co..South Bend, Ind.
 Sheboygan National Gas Co.Sheboygan, Wis.
 Salina Gas Light Co.....Salina, Kansas.
 The Rathbun Co.....Deseronto, Prov.Ont.
 Jefferson City Gas Lt. Co..Jefferson City,Mo.
 Mankato Gas Light Co....Mankato, Minn.
 Lima Gas Light Co...Lima, Ohio.

Minneapolis Gas Light and
 Coke Co.....Minneapolis, Minn.
 Bellevue Water and Fuel }
 Gas Light Co..... } Bellevue, Campbell
 County, Ky.
 Bucyrus Gas Lt. & Fuel Co.Bucyrus, Ohio.
 Morris Gas Co.....Morris, Ill.
 Los Angeles Gas Co.....Los Angeles, Cal.
 San Diego Gas Fuel & Elec-
 tric Lt. Co.....San Diego, Cal.
 Sioux Falls Gas Co.....Sioux Falls, Dak.
 Dakota Gas and Fuel Co..Grand Forks, Dak.
 St. Johns Mutual Gas Co..St. Johns, Mich.
 Stillwater Gas Light Co...Stillwater, Minn.
 St. Paul Gas Light Co....St. Paul, Minn.
 Emporia Electric and Gas
 Light Co.....Emporia, Kas.
 Van Wert Gas Light Co...Van Wert, Ohio.
 Lansing Gas Light Co.....Lansing, Mich.
 San Francisco Gas Lt. Co..San Francisco, Cal.

Shelbyville Gas Light Co..Shelbyville, Ind.
 Great Falls Gas Light Co.. Great Falls, N. H.
 Belleville Gas Co.....Belleville, Ontario
 Rochester Lt. and Fuel Co..Rochester, Minn.
 Northwestern Gas Light and
 Coke Co.....Evanston, Ill.
 Lincoln Gas Light Co.....Lincoln, Neb.
 Davenport Gas Light Co...Davenport, Iowa.
 Municipal Gas Co.....Albany, N. Y.
 Alliance Gas Light Co.....Alliance, Ohio.
 New Gas Light Co.....Janesville, Wis.
 Chicago Gas Lt. & Coke Co., Chicago, Ill.
 Joliet Gas Co.....Joliet, Ills.
 Superior Light & Fuel Co..Superior, Wis.
 Kewanee Gas Light Co...Kewanee, Ill.
 Aberdeen Light & Fuel Co..Aberdeen, So. Dak.
 Pierre Light and Fuel Co..Pierre, So. Dak.
 *Standard Gas Light Co...New York City.
 *Carlinville Gas Light Co..Carlinville, Ill.

* Building.

CUARANTEED ESTIMATES of Cost of Gas Furnished on Application.

GASHOLDER TANK CONSTRUCTION, ETC.

Gas Companies and others about to erect Gasholders will find it profitable to consult W. C. Whyte, who for over 30 years has made a specialty of

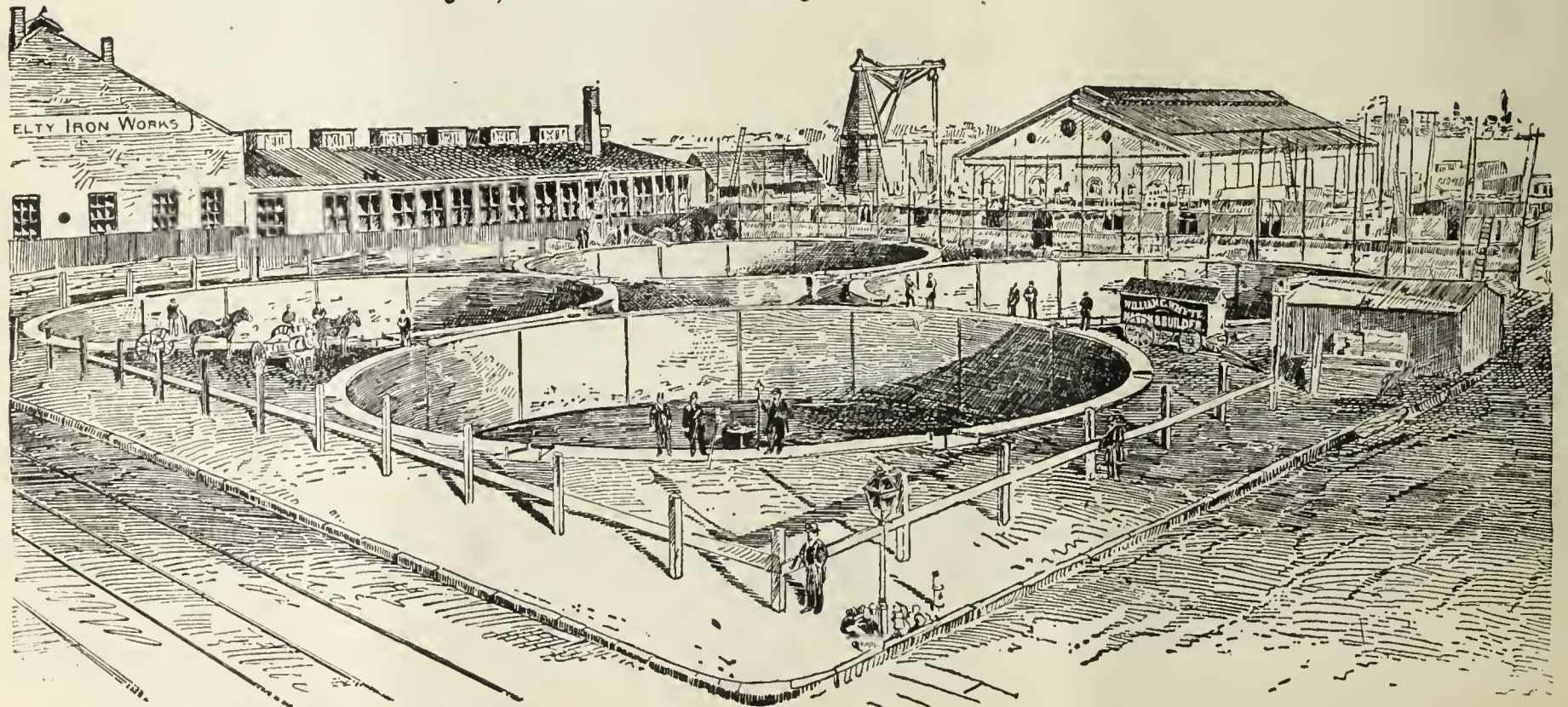

Tank Excavation and Mason Work.

Fifty Tanks now in operation show the sort of work done. Address

W. C. WHYTE, - No. 15 Cortlandt Street, N. Y. City.

CONNELLY & CO.,

SOLE MANUFACTURERS OF THEIR PATENTED SPECIALTIES.

"IRON SPONGE." Saves money, saves labor, and is the most efficient purifying agent ever offered as a substitute for lime. Now used in every State in the Union, and purifying daily over thirty-five million cubic feet. Should be used in every gas works. Its own saving will pay for it many times over.

AUTOMATIC GOVERNOR. Has been on the market but three years, and in that time has been introduced more generally than any invention ever designed for use in gas works. Over two hundred of them now in use. Sensitive; reliable; perfectly automatic; reduces leakage; satisfies consumers, and gives great relief to the Manager. No gas works is complete without one of these machines.

STEAM JET EXHAUSTER. Designed particularly for small works. Combines Exhaust Tube, Steam Governor Gas Compensator, and Bye-Pass Valves in the most compact form possible; occupies but little space; uses very little steam; operated by ordinary workmen; saves formation of carbon in retorts; increases yield 10 to 15 per cent. Specially adapted for mixing air with oil gas. No works too small to use them profitably.

Prices given on all our specialties delivered at any point in the United States. Correspondence solicited.

CONNELLY & CO., No. 111 Broadway, New York City.

WILBRAHAM GAS EXHAUSTER

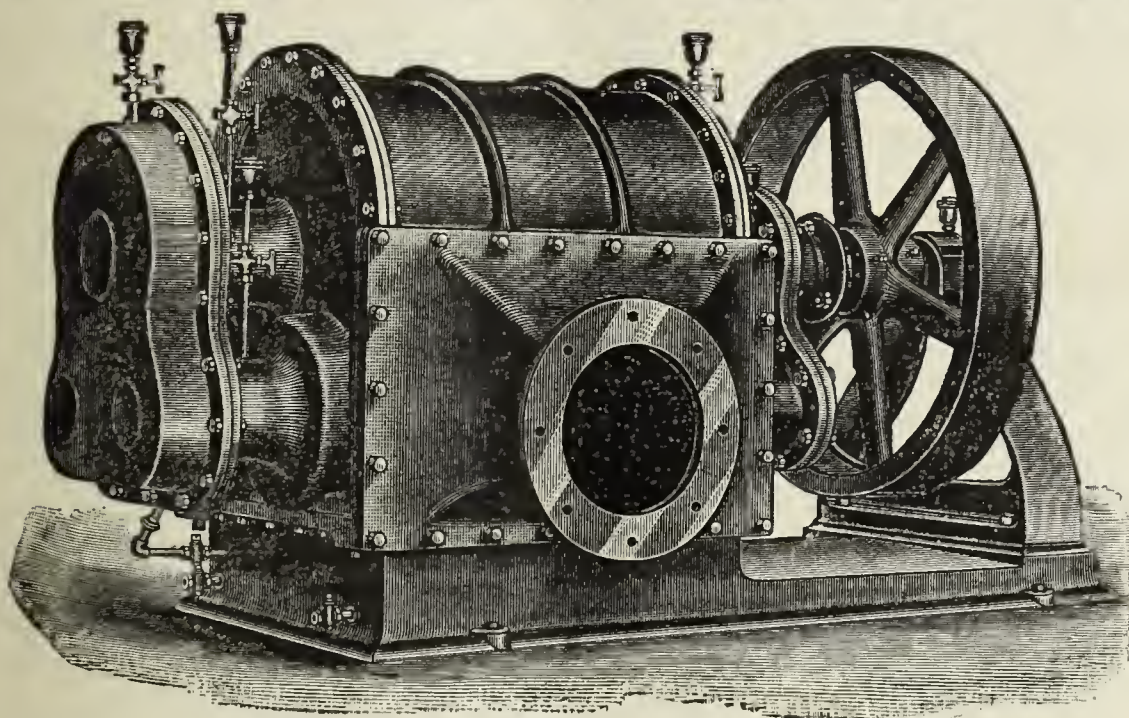

WILBRAHAM BROS.,
PHILADELPHIA, PA.

JARVIS ENGINEERING CO.,

61 Oliver St., Boston, Mass.

CONTRACTORS FOR ERECTING

COMPLETE STEAM OUTFITS FOR ELECTRIC LIGHTING STATIONS.

Steel Boilers set with Jarvis Pat. Boiler Setting

To burn **COKE SCREENINGS** for Fuel.

ARMINGTON & SIMS CO. ENGINES,

Belted direct to Dynamos, without using Shafting.

SEND FOR CIRCULARS.

REFERENCES.—Charlestown Gas & Electric Light Co., Charlestown, Mass.; Schenectady Gas & Electric Light Co., Schenectady N. Y.; Brookline Gas Co., Brookline, Mass.

Practical Electric Lighting

By A. BROMLEY HOLMES, A.M.I.C.E.

With 87 Illustrations. Third Edition. Price, \$1.00.

Electric Light Primer.

By CHARLES L. LEVEY.

A simple and comprehensive Digest of all the most important facts connected with the running of the Dynamo and Electric Lights, with Precautions for Safety, etc.

Price, 50 cents.

A. M. CALLENDER & CO., 42 Pine St., N.Y.

(Patented.)

IMPORTANT!

(Patented)

NEW SOLVENT FOR GAS PIPE DEPOSITS.

Economical and Effective.

MAAS & WALDSTEIN, 44 Trinity Place and 81 Greenwich St., N. Y.

Gasholder Tanks & Gas Works Masonry Complete.

PLANS PREPARED AND ESTIMATES FURNISHED AT SHORT NOTICE.

J. P. WHITTIER, - - 499 Wythe Av., Brooklyn, N. Y.

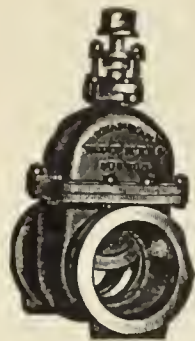

CHAPMAN VALVE MANUFACTURING CO.,

MANUFACTURERS OF

Valves and Gates for Gas, Ammonia, Water, Etc.

Also, Gate Fire Hydrants With and Without Independent Nozzle Valve. All Work Guaranteed.

WORKS & GEN'L OFFICE:
Indian Orchard, Mass.

TREASURER'S OFFICE:
72 Kilby & 112 Milk Sts, Boston, Mass.

LUDLOW VALVE MFG. CO.



OFFICE AND WORKS,

938 to 954 River Street and 67 to 83 Vall Av.,
TROY, N. Y.

Parson's Steam Blower,

FOR IMPROVING BAD DRAUGHT IN BOILERS, AND FOR BURNING BREEZE OR OTHER WASTE MATERIAL.

PARSON'S TAR BURNER,

FOR UTILIZING COAL TAR AS FUEL.

PARSON'S AIR JET TUBE CLEANER,

FOR CLEANING BOILER TUBES.

These devices are all first-class. They will be sent to any responsible party for trial. No sale unless satisfactory. Manufactured by the WATERTOWN STEAM BLOWER COMPANY.

H. E. PARSON. Supt., 33 & 35 Liberty St., N.Y.

Hydraulic Main Dip Regulators, also
Check Valves, Foot Valves, Yard-
wash and Fire Hydrants.
Send for Circulars.



Valves.—Double and Single Gate, 1/2 in. to
48 in., outside and inside Screws. Indica-
tor, etc., for Gas, Water, Steam, and Oil.
Send for Circulars.

MILLS' REVERSIBLE LIME TRAY,

AND

WOODWORK

Of Every Description

NEEDED BY GAS WORKS.

SEND FOR CIRCULAR AND PRICE LIST TO

BARTLETT, HAYWARD & CO.,

Pratt and Scott Streets, Baltimore, Md.

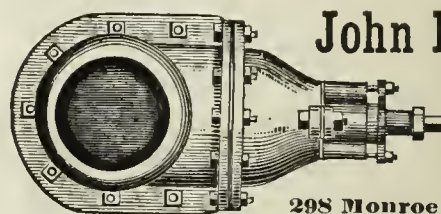
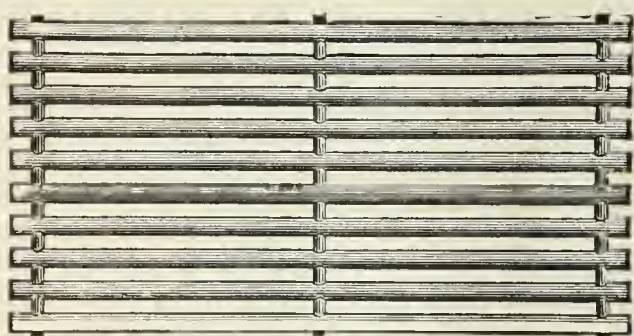

John McLean

Manufacturer

GAS VALVES.

298 Monroe Street, N. Y.

VAN DUZEN GAS & GASOLINE ENGINE

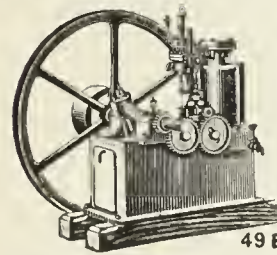

OPERATED with COAL and OTHER MANUFACTURED GASES AND GASOLINE.

RELIABLE AND ECONOMICAL.

Fully Warranted

VAN DUZEN

Gas & Gasoline Engine Co.

49 E. 2d St., Cincinnati, O.

A. MacKinnon Machine Co., Agts., 22 Warren St., N.Y.

The Management of Small Gas Works.

BY C. J. R. HUMPHREYS.

Price, \$1.

Orders to be sent to **A. M. CALLENDER & CO.,**

42 PINE STREET, NEW YORK.

SPECIAL TRAYS FOR IRON SPONGE OR OXIDE OF IRON. CHURCH'S TRAYS A SPECIALTY.

REVERSIBLE—STRONGEST—MOST DURABLE—MOST EASILY REPAIRED.

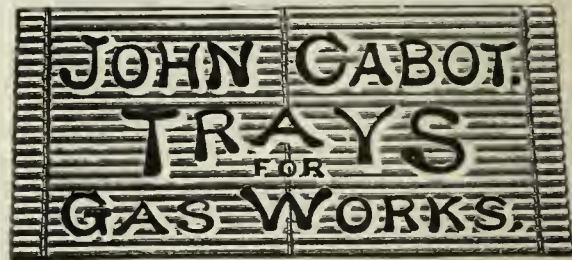

306-310 ELEVENTH AVENUE, NEW YORK.

WE ALSO MAKE THE CHEAPEST AND STRONGEST REVERSIBLE BOLTED TRAYS IN THE MARKET.

THE CLERK GAS ENGINE CO.,

Main Office, 1012, 1014, 1016, 1018 Filbert St., Philadelphia, Pa.

WM. W. GOODWIN, Prest.

E. STEIN, Sec.

S. LEWIS JONES, Asst. Sec.

A. J. DOTY, Supt.

The utility and convenience of the Gas Engine being no longer an open question, it only remains now for intending purchasers to select the BEST. We claim for the CLERK GAS ENGINE that it is equal to any other manufactured as regards steadiness in running, simplicity, and ease of keeping in repair, and that it gives the greatest amount of power for the least money (both in first cost and expense of running) of any engine made. In support of this claim we refer to the test of the Gas Engines made under the direction of the American Institute of New York, in December, 1885, and heretofore published in these columns. These engines are especially adapted for continuous running under heavy loads, and we can refer to Engines which have run 22 hours a day for months at a time

Made in Sizes of 5 10 15 20, and 25 Horse Power. All Engines Guaranteed for One Year.

GAS STOVES.

GAS METERS.

GAS STOVES.

THE AMERICAN METER CO.,

MANUFACTURERS OF

GAS METERS, Station Meters,

METER PROVERS, PHOTOMETERS,
PRESSURE GAUGES OF ALL KINDS,



Standard 3 Diaphragm Dry Meter

AND



Standard 2 Diaphragm Dry Meter.

Apparatus for Testing the Quantity and Quality of Gases.

GAS STOVES FOR HEATING AND COOKING

Sole Agents in the United States for

Verity's Patent Gas Fires.

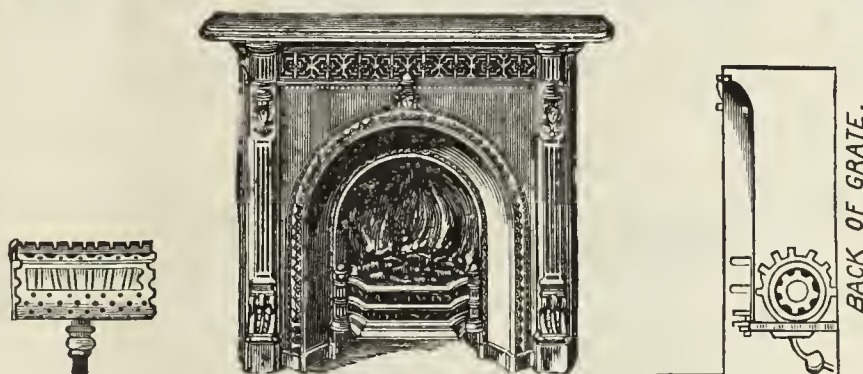

Circulars and Price Lists on Application.

MANUFACTORIES,

508 to 514 West Twenty-second St., N. Y.

Arch and Twenty-second St., Phila.

Nos. 244 & 246 North Wells Street, Chicago, Ill.

AGENCIES,

No. 177 Elm Street, Cincinnati, Ohio.

No. 222 Sutter Street, San Francisco, Cal.

No. 810 North Second Street, St. Louis, Mo.

GAS STOVE SHOW ROOMS, No 242 Sixth Avenue, New York City.

RETORTS AND FIRE BRICK.

J. H. CAUTIER & CO.,
CORNER OF
GREENE AND ESSEX STREETS,
JERSEY CITY, N. J.

MANUFACTURERS OF
**Clay Gas Retorts,
Gas House Tiles,
Fire Bricks, Etc. Etc.**
Ground Clay, Fire Brick and
Fire Sand in Barrels,

J. H. GAUTIER. C. E. GREGORY. C. E. GAUTIER.

BROOKLYN
Clay Retort & Fire Brick Works,
(EDWARD D. WHITE & CO.)
Manufacturers of Clay Retorts, Fire Brick,
Gas House and other Tile.
VAN DYKE, ELIZABETH, RICHARDS & PARTITION STS.
Office, 88 Van Dyke St., Brooklyn, N. Y.

RETORTS AND FIRE BRICK.

LACLEDE FIRE BRICK MFG. CO.,
MANUFACTURERS OF
Fire Brick, Gas Retorts,

AND
ST. LOUIS STANDARD SEWER PIPE.
Blast Furnace and Cupola Linings, every description of Fire
Clay Material, Fire Clay Flue Linings, Chimney Tops
Dry Milled and Crude Fire Clays, etc.
OFFICE AND DEPOT
901, 903, and 905 Pine Street,
ST. LOUIS, MO.

ESTABLISHED IN 1845.
B. KREISCHER & SONS,
OFFICE FOOT OF HOUSTON ST., E. B., N. Y.
**Gas Retorts,
TILES, FIRE BRICK.**
AND EVERYTHING IN THE FIRE CLAY LINE.

RETORTS AND FIRE BRICK.

MANHATTAN
FIRE BRICK & ENAMELLED CLAY
RETORT WORKS
ADAM WEBER.
CLAY GAS RETORTS
AND RETORT SETTINGS
FIRE BRICKS, TILES, ETC.,
Office and Works, 15th Street and Avenue C., N. Y.

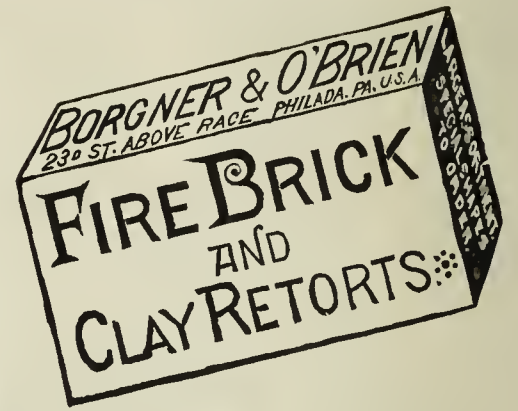

Works,
LOCKPORT STATION, PA.

—ESTABLISHED 1864.—
JAMES GARDNER, JR.,

Office, Rooms 19 & 20, Lewis Block,
PITTSBURGH, PA. P. O. Box 373.

Successor to WILLIAM GARDNER & SON.

Fire Clay Goods for Gas Works.

H. A. NORTON, No. 4 CENTRAL STREET, BOSTON, MASS., Agent for the New England States.

GEO. C. HICKS, Pres. **CHICAGO** CHAS. A. REED, Sec. & Treas.
Retort and Fire Brick Co.,
MANUFACTURERS OF
Fire Clay Goods of all Kinds,
AND BEST QUALITY ONLY.
Regenerative Furnaces & Water Gas Goods.
45th St., Clark to La Salle, Chicago.

GEROULD'S IMPROVED RETORT CEMENT.
A Cement for patching retorts, putting on mouthpieces, and
making up all bench-work joints. This Cement is mixed ready
or use. Economic and thorough in its work. Fully warranted
o stick. For recommendations and price list address
C. L. GEROULD & CO.,
5 & 7 Skillman St., Brooklyn, N. Y.
Western Agent, H. T. GEROULD, Mendota, Ill.

Parker-Russell
Mining and Mfg. Co.,
CITY OFFICE,
Mermod-Jaccard Bldg., Rooms 307 & 308,
Broadway & Locust St., St. Louis. Mo.

PROPRIETORS OF THE
OAKHILL GAS RETORT & FIRE BRICK W'KS
Our immense establishment is now employed almost entirely in
the manufacture of
Materia's for Gas Companies
We have studied and perfected three important points. Our re-
torts are made to stand changes of temperature, the strongest
heats of the furnace, and the abrasion of feeding and emptying.
We have the *exclusive Agency for the West* of the celebrated
**Kloenne-Bredel Full Depth and
Semi-Recuperator Benches,**
And also furnish and build
Our Own Styles Semi-Recuperator Furnaces
for the use of Coal or Coke as fuel.

THOS. SMITH, Prest. AUGUST LAMBLA, Vice-Prest. & Supt.
BALTIMORE
RETORT & FIRE BRICK CO.
MANUFACTORY AT
LOCUST POINT, BALTIMORE, MD.
Clay Retorts, Blocks & Tiles,
FIRE BRICK, FIRE CLAY,
AND FIRE CEMENT.
Red and Buff Ornamental Tiles and Chim-
ney Tops. Drain and Sewer Pipe (from
2 to 30 inches). Baker Oven Tiles
12x12x2 and 10x10x2.
WALDO BROS., 88 WATER ST., BOSTON, MASS.
Sole Agents the New England States.

1889 DIRECTORY 1889
OF THE GAS LIGHT COMPANIES of the UNITED STATES & CANADA.
Price, \$3.00.
A. M. CALLENDER & CO., No. 42 Pine Street, N. Y. City.

HENRY MAURER & SON,

(ESTABLISHED 1856.)

**EXCELSIOR FIRE BRICK & CLAY
RETORT WORKS**

WORKS, Perth Amboy, N. J.
OFFICE, 418 to 422 East 23d St., N. Y.

**Clay Gas Retorts,
BENCH SETTINGS,
Fire Brick, Tiles, Etc.**

**FLEMMING'S
Generator-Gas Furnace**

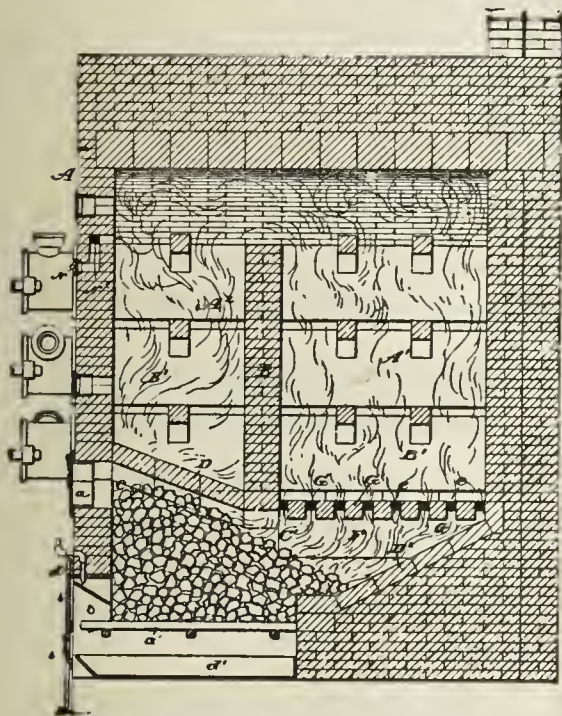

Materials furnished and Benches erected by

J. H. GAUTIER & CO., - Jersey City, N. J.

Address as above, or D. D. FLEMMING, Jersey City, N. J.

FRED. BREDEL,

CONTRACTOR FOR THE COMPLETE

Erection and Equipment of Gas Works.

SOLE PROPRIETOR OF THE

KLOENNE PATENTS

FOR NORTH AMERICA.

REGENERATIVE FURNACES.

(900 Retorts are now fired in America by the Kloenne-Bredel System.)

SELF-SEALING MOUTHPIECES.

(Over 800 Now in Use.)

Standard Condensers. Washer-Scrubbers.

TAR WASHERS FOR WATER GAS PLANTS.

(In use in the works of the Chicago Gas Lt. Co.)

GASHOLDERS.

Bredel's Automatic Gas Governor.

Refers, by permission, to Mr. Eugene Vanderpool, Newark, N. J.; Mr E. G. Cowdery, Milwaukee, Wis.; and Mr. Theo. Forstall, Chicago, Ills
For further information, address

FRED. BREDEL,

No. 208 East Seventeenth Street, N. Y. City.

COMPOUND Condensing or Non-Condensing.
16 SIZES, 5 to 500 H. P.
Not yet equaled by any form of Engine for
HIGH FUEL DUTY AND SIMPLICITY.

STANDARD 13 Sizes in Stock.
5 to 250 H. P.
3000 in use in all parts of the Civilized World.

JUNIOR 6 Sizes in Stock,
5 to 50 H. P.
An Automatic Engine cheaper than a Slide Valve.
WELL BUILT. ECONOMICAL. RELIABLE.
Over 300 Sold the First Year.

All the above built strictly to Gauge with
INTERCHANGEABLE PARTS.
REPAIRS CARRIED IN STOCK.
SEND FOR ILLUSTRATED CATALOGUES.

**WESTINGHOUSE
ENGINES**
The Westinghouse Machine Co.
PITTSBURGH, PA. U.S.A.

SELLING DEPARTMENT IN THE UNITED STATES.

New York,	17 Cortlandt St.	} Westinghouse, Church, Kerr & Co.
Boston,	Hathaway Building,	
Pittsburgh,	Westinghouse Build'g,	
Chicago,	156, 158 Lake St.	
Philadelphia,	608 Chestnut St.	M. R. Muckle, Jr. & Co.

ST. LOUIS,

511 NORTH FOURTH ST.,

Westinghouse, Church, Kerr & Co.

Salt Lake City,	259 S. Main St.	} Utah & Montana Machinery Co.
Butte, Mont.	2. Granite St.	
San Francisco,	21, 23 Fremont Street,	Parke & Lacy Co.
Portland, Or.	33, 35 N. Front St.	Parke & Lacy Mch. Co.
Charlotte, N. C.	36 College St.	} The D. A. Tompkins Co.
Atlanta, Ga.	45 S. Prior St.	
Dallas, Tex.	Keating Imp. & Machine Co.	
Chattanooga, Tenn.,	G. E. James & Co.	

Newbigging's Handbook for Gas Engineers and Managers.

The present (the fifth) edition marks an important advance on those that have gone before. Considerable additions have been made to the text, and much of it has been re-written and otherwise improved. It extends to 524 pages, and contains 193 illustrations. Price, Cloth, \$6.00.

A. M. CALLENDER & CO., - - - No. 42 Pine Street, N. Y. City.

GAS AND WATER PIPES.

GAS AND WATER PIPES.

ENGINEERS.

SAM'L R. SHIPLEY, Pres.
HENRY B. CHEW, Tre.

JAS. P. MICHELLON, Sec.
WM. SEXTON, Supt.

GLOUCESTER IRON WORKS,
GLOUCESTER CITY, N. J.



Cast Iron Gas & Water Pipes, Stop Valves, Fire Hydrants, Gasholders. &c.

Office, Rooms 61 and 63 Bullitt Building, 131 S. 4th St., Phila., Pa.

WARREN FOUNDRY AND MACHINE CO.,

Established 1856. Works at Phillipsburgh, N. J.

New York Office, 160 Broadway.

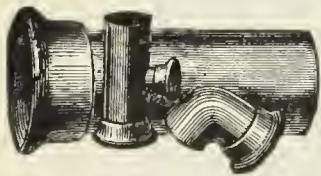

CAST IRON WATER AND GAS PIPE,

FROM TWO TO FORTY-EIGHT INCHES DIAMETER. ALSO, ALL SIZES OF

Flange Pipe for Sugar House and Mine Work. Branches, Bends, Retorts, etc., etc.

DENNIS LONG & COMPANY,

LOUISVILLE, KY.,



Manufacture Exclusively

CAST IRON GAS & WATER PIPE & SPECIAL CASTINGS
OF ALL SIZES.

King's Treatise on Coal Gas.

A standard text-book for the Engineers and Managers of Gas Works, and for all who are concerned or take an interest in the manufacture and distribution of Coal Gas, and in the utilization of the Secondary Products resulting therefrom; treating also of the Gas Engine, and of Gas Cooking and Heating Appliances.

In 3 Vols. Price per Vol., \$10. Sold either by Volume or in Sets.

A M. CALLENDER & CO., 42 Pine St., N. Y.

P. D. WANNER, Chairman. A. H. MELLERT, Mangr. of Wks.
R. B. KINSEY, Secretary. F. A. KNOPP, Treasurer.

MELLERT FOUNDRY & MACHINE CO. Ltd.
and **READING FOUNDRY CO., Ltd.**

Reading, Pa.



Specials—Flange Pipe, Valves and Hydrants
Lamp Posts, Retorts, etc.

General Foundry and Machine Work.

JOHN FOX, Selling Agent. 160 Broadway, N.Y.

THE OHIO PIPE COMPANY,

MANUFACTURERS OF

Cast Iron Gas & Water Pipe,

BRANCH AND SPECIAL CASTINGS.

Gas-House Bench Castings, Hydraulics, Lamp Posts, Flange Pipe
and Specials, Architectural Castings, Building Columns,
Joists, Cellar Grates, Sash Weights, etc.

GENERAL FOUNDERS AND MACHINISTS.

Columbus, Ohio.

M. J. DRUMMOND,



SPECIAL CASTINGS AND LAMP POSTS.

Office, Corbin Building, 192 Broadway, N. Y.

EMAUS PIPE FOUNDRY.

DONALDSON IRON COMPANY. EMAUS, PA.



MANUFACTURERS OF

CAST IRON PIPE AND SPECIAL CASTINGS
FOR WATER AND GAS.

JOS. R. THOMAS,

No. 42 Pine Street, N.Y. City.

CONSULTING AND CONSTRUCTING

Gas Engineer and Contractor.

PLANS, SPECIFICATIONS, AND ESTIMATES
FURNISHED.

Contracts taken for all Appliances
required at a Gas Works,

Either for New Works or Extensions to Old Plants.

WM. MOONEY

(Successor to WM. FARMER)

No. 94 Liberty St., N Y. City.

GAS ENGINEER AND CONTRACTOR FOR THE ERECTION
OF GAS WORKS, OR APPARATUS OF ANY
CAPACITY.

Plans and Specifications Furnished.

WM. GARDNER,
Gas Engineer,

Lewis Block, Room 20, Pittsburgh, Pa.

Those who intend to make alterations in existing gas plants, or who contemplate the erection of new works, will find it to their interest to open correspondence with the above. Plans made and estimates furnished.

ARTLETT, HAYWARD & CO.

Baltimore, Md.

Triple Double, & Single-Lift
GASHOLDERS.

Iron Holder Tanks.

ROOF FRAMES.

Cirders.

BEAMS.

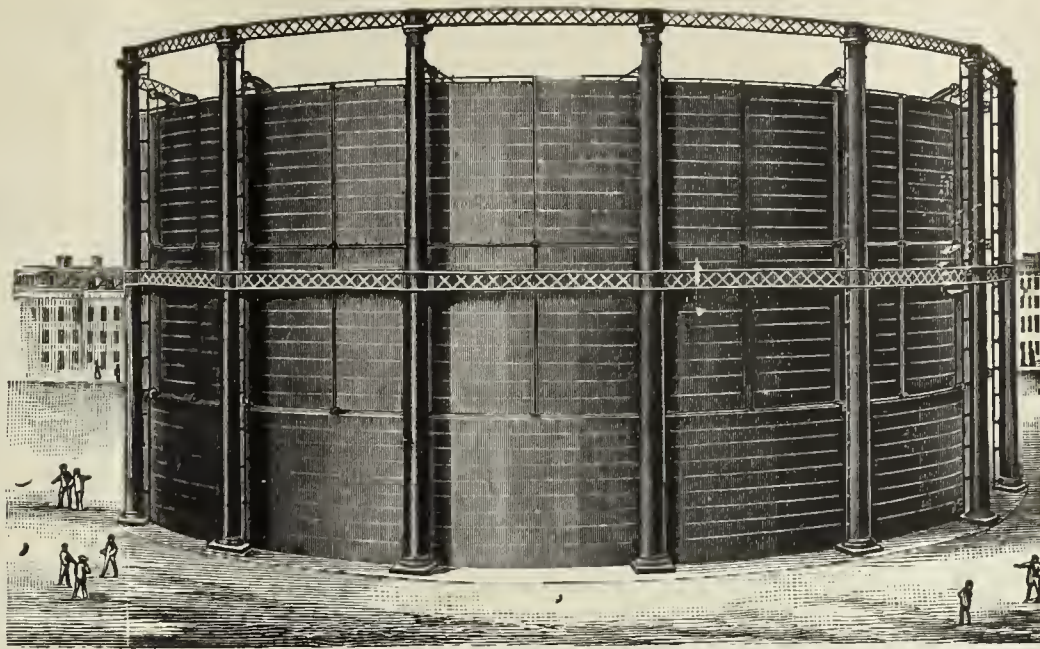

PURIFIERS.

CONDENSERS.

Scrubbers.

BENCH CASTINGS.

OIL STORAGE TANKS.

Boilers.

The Wilkinson Water Gas Process.

THIRTY-CANDLE, NON-CONDENSABLE, FIXED GAS. THE MOST SUCCESSFUL GAS PROCESS IN OPERATION.

Munich Regenerative Furnace, System Drs. Schilling & Bunte.

HAZELTON BOILERS.

Gas Works Designed and Constructed.

Pascal Iron Works. ESTABLISHED 1821. Delaware Iron Works.

MORRIS, TASKER & CO.,

INCORPORATED.

OFFICE, 224 SOUTH THIRD STREET, - - PHILADELPHIA, PA.

CONTRACTORS, BUILDERS, AND MANUFACTURERS OF

Gas, Water & Sugar Works

Bench Castings.

Condensers.

Scrubbers.

Purifiers.

Hyd. Carriages.

Iron Floors,

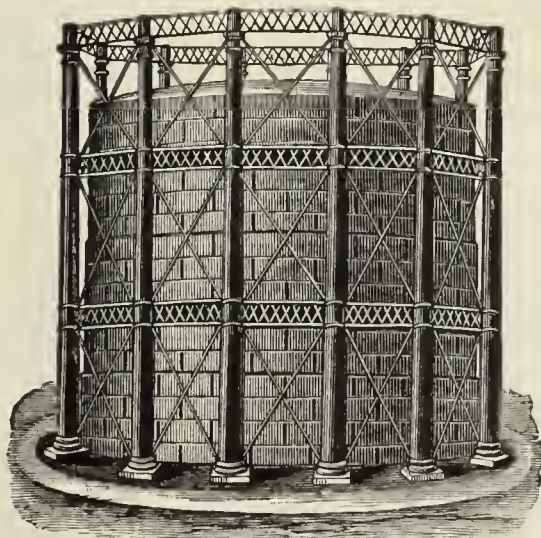

Iron Roofs.

Street Stops,

Valves, etc.

Stand-Pipes.

Water & Oil

Tanks, all Sizes.

Single, Double, and Triple-Lift Gas Holders.

SELF-SEALING RETORT LIDS. STAMPED STEEL RETORT LIDS.

Locomotive Water Columns, Filters, etc. Boiler Tubes, Wrought Iron Pipe & Fittings

Plans, Specifications and Estimates for all kinds of Machinery furnished on application.

Foundries & Works,
MILLVILLE, FLORENCE,
and CAMDEN, N. J.

R. D. WOOD & CO.,

Engineers,
Iron Founders,
and
Machinists.

400 Chestnut St., PHILADELPHIA, PA.

MANUFACTURERS OF

CAST IRON PIPE,

Gas Holders,

SINGLE, DOUBLE, AND TRIPLE LIFTS, WITH
OR WITHOUT WROUGHT IRON
OR STEEL TANKS.

PURIFIERS, CONDENSERS.

Scrubbers.

BENCH WORK.

Iron Floors and Roofs, Plate Girders.

Heavy Loam Castings.

HYDRAULIC WORK.

Lamp Posts, Valves, Etc.

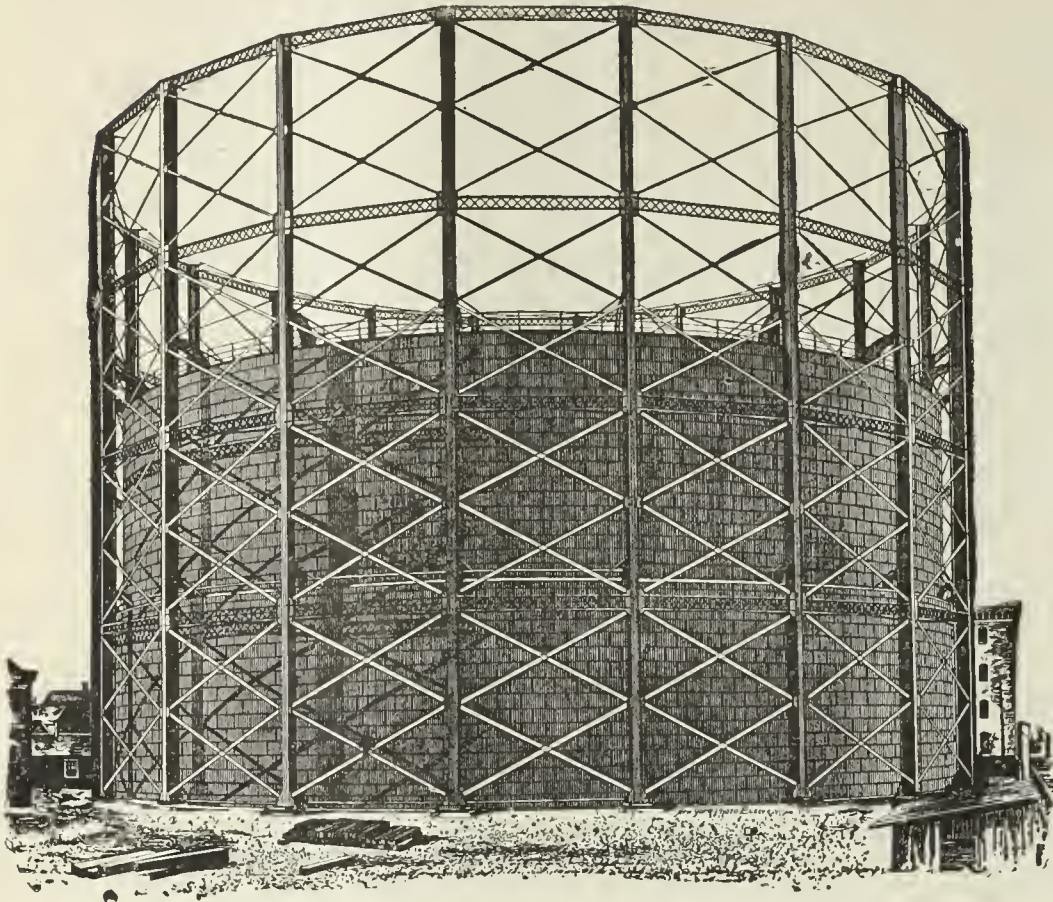

SMITH & SAYRE MFG. COMPANY,

G. G. PORTER, Prest.

245 Broadway, N. Y.

CHAS. W. ISBELL, Sec'y.

Machinery & Apparatus for Gas Works

Drawings, Plans, and Estimates Furnished for the Improvement, Extension, or Alteration of Gas Works, or for the Construction of New Works.

Mackenzie's Patent Rotary and Steam Jet Gas Exhausters, Governors, Compensators, Condensers, Washers, Scrubbers. Isbell's Patent Automatic Street Pressure Governor, Gas and Water Valves, Hydraulic Main Dip Regulator, Bench Castings, etc. Purifying Boxes and "Standard" Scrubbers. Isbell's Patent Self-Sealing Retort Doors.

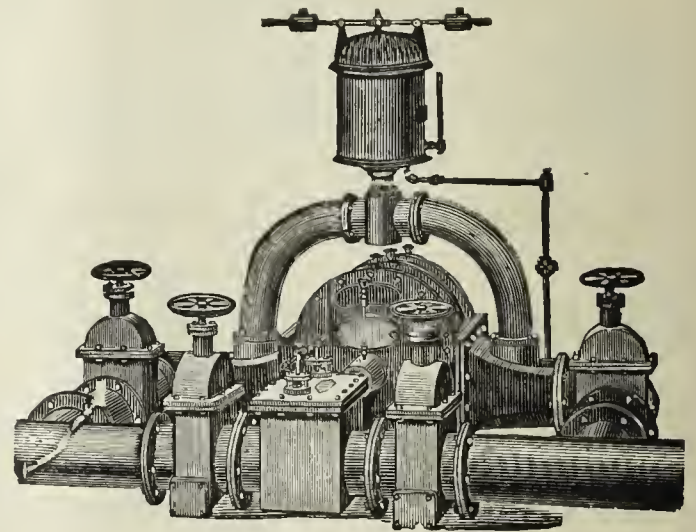

THE BRENNER SELF-SEALING RETORT DOOR.

Simple, Strong, and Durable.

CLOSES ABSOLUTELY TIGHT & IS LOCKED BY A CAM LEVER. ALL NECESSARY ADJUSTMENT FOR WEAR PROVIDED.

BUILT BY

SMITH & SAYRE MFG. CO.,

No. 245 Broadway, - - - New York City.

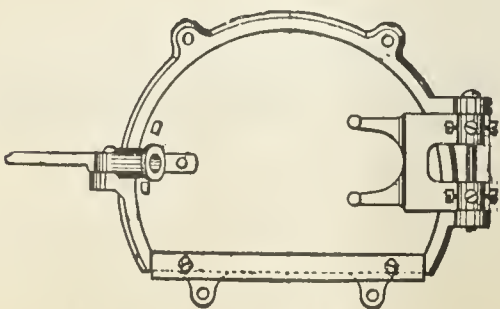

Brenner Self-Sealing Retort Door.

WILLIAM B. LUNDIE, Superintendent of the 42d Street Station of the Consolidated Gas Company, of New York, writes, under date of Jan. 4, 1889:

"We have 320 Brenner Self-Sealing Lids in use at this Station, built by the Smith & Sayre Mfg. Co. They require very little attention, and are the best of the kind that I have seen, giving entire satisfaction."

GAS WORKS APPARATUS AND CONSTRUCTION.

GAS WORKS APPARATUS AND CONSTRUCTION.

JAMES R. FLOYD & SONS,

(SUCCESSORS TO HERRING & FLOYD)

Oregon Iron Works,

W. 20th & 21st. Sts., bet. 10th & 11th Avs.,

NEW YORK CITY.

Engineers and Contractors

FOR THE

CONSTRUCTION OF GAS WORKS.

MANUFACTURERS OF

All Kinds of Castings and General Ironwork

FOR

GAS APPARATUS.

Bench Castings, Regenerative and Half Regenerative Furnace Castings.

Condensers, Scrubbers, Purifiers, Street Drips and Connections,

Valves,

Hydraulic Hoisting Purifier Carriage, Self-Sealing Retort Lids, Improved

Valve Stand and Indicator,

Seller's Cement.

Plans, Specifications, and Estimates furnished for Construction of New or Alteration of Old Works.

CONTINENTAL IRON WORKS.

THOS. F. ROWLAND, Prest.

WARREN E. HILL and CHAS. H. CORBETT, V-Prests.

THOS. F. ROWLAND, JR., Sec. & Tr

P. O. Station G., BROOKLYN, N. Y.

ENGINEERS AND MANUFACTURERS OF

Gas Holders

CONDENSERS, SCRUBBERS, VALVES,

PURIFIERS, SELF-SEALING RETORT LIDS

Hydraulic Mains,

And all other articles connected with the manufacture and distribution of Gas.

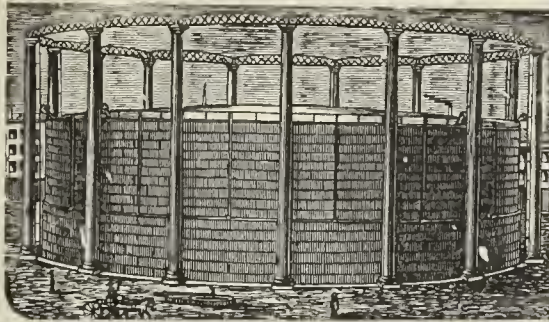

H. RANSHAW, Prest. & Mangr.

WM. STACEY, Vice-Prest.

T. H. BIRCH, Asst. Mangr.

R. J. TARVIN, Sec. & Treas.

STACEY MFG. CO.,

MANUFACTURERS OF

Single and Telescopic Gasholders,

IRON ROOFS, BRIDGES, LAMP POSTS,

Water and Oil Tanks, Coal Elevator Cars,

COKE CRUSHERS, BENCH CASTINGS,

And all kinds of Wrought and Cast Iron Work used in the erection of Coal and Oil Gas Works Rolling Mill Machinery and Heavy Castings a Specialty.

Foundry:

33, 35, 37 & 39 Mill Street.

Wrought Iron Works:

16, 18, 20, 22, 24 & 26 Ramsey Street:

Cincinnati, Ohio.

Bouton Foundry Co.,

FOUNDERS AND MACHINISTS,

CHICAGO, ILL.

Gas Works Apparatus,

PURIFIERS, CONDENSERS,

Bench Work

SPECIALS, LAMP POSTS,

SCRUBBERS,

Iron Roofs and Floors.

Plans and Estimates furnished for new works or extensions of old works.

1842. **DEILY & FOWLER,** 1889.

Laurel Iron Works.

Address, No. 39 Laurel Street, Philadelphia, Pa.

BUILDERS OF

GASHOLDERS,

Single and Telescopic.

HOLDERS BUILT 1884 TO 1888, INCLUSIVE:

- | | | | | |
|----------------------------|-----------------------------|---------------------------|--------------------------|------------------------|
| Newport, R. I. | Long Island City, N. Y. | Port Chester, N. Y. | Malden, Mass. | West Chester, Pa. (2d) |
| Portland, Oregon. | Macon, Ga. | New Rochelle, N. Y. | Paducah, Ky. | Lancaster, Pa. (3d) |
| Allegheny, Pa. (2d.) | York, Pa. | Salem, N. J. (3d) | Norwich, Conn. | Facony, Pa. (two) |
| Atlanta, Ga. (2d.) | Chester, Pa. | Omaha, Neb. (2d) | Seattle, W. T. | Mount Vernon, N. Y. |
| N.Y. City (Central Gas Co) | Hazleton, Pa. (2d.) | Lynn, Mass. (2d) | San Diego, Cal. | Binghamton, N. Y. |
| Lynchburg, Va. (2d.) | Staten Island, N. Y. | Little Rock, Ark. | Northern Gas Lt. Co., of | Concord, N. H. |
| Saylesville, R. I. | Saugerties, N. Y. | Irrington, N. Y. | New York, N. Y. | Dover, Del. (2d) |
| Rondout, N. Y. | Clinton, Mass. (Lan. Mills) | South Boston, Mass. | Westerly, R. I. | Calais, Me. |
| Atlantic City, N. J. | Chattanooga, Tenu. | Rye, N. Y. (2) | Willimantic, Conn | New Loudon, Conn. (2d) |
| Augusta, Ga. | Galveston, Texas. (3d.) | Woodstock, Ont. | Montclair, N. J. | West Chester, N. Y. |
| Waltham, Mass. (2) | Omaha, Neb. | Malden, Mass. | Attleboro, Mass. | Bay Shore, L. I. |
| Mahanoy City, Pa. | Fort Plain, N. Y. | Staten Island, N. Y. (2d) | Santa Cruz, Cal. | Washington, D. C. |
| New Castle, Pa. | Brunswick, Ga. | Woodstock, Ont. | Erie, Pa. (2d) | |

WM. HENRY WHITE,

No. 32 Pine Street, - - - New York City.

ENGINEER AND CONTRACTOR FOR THE

Erection and Extension of Gas, Water, and Electric Light Works.

SOLE REPRESENTATIVE OF THE

McILHENNY REGENERATOR FURNACE PATENTS

And the Martin Water Gas Process.

Edison Incandescent and American Arc Electric Light Plants Installed.

Correspondence with Gas Companies contemplating extending or improving their Plants respectfully invited. Plans and Estimates Furnished.

GAS COALS.

CANNEL COALS.

GAS ENRICHERS.

JAMES D. PERKINS. **PERKINS & CO.,** F. SEAVERNES.
 228 & 229 Produce Exchange, New York.
 Cable Address, "PERKINS, NEW YORK." Post Office Box 3695, New York.

GENERAL SALES AGENTS FOR

The Youghiogeny River Coal Company's
OCEAN MINE YOUGHIOGHENY GAS COAL.

HON. W. L. SCOTT, Prest. M. H. TAYLOR, Vice-Prest.

This Colliery is located at SCOTT HAVEN, PA., in the center of the Youghiogeny Gas Coal District, and produces the ONLY RELIABLE YOUGHIOGHENY COAL for gas purposes. (See Map on p. 87 of this JOURNAL, Feb. 16, '85.)

POINTS OF SHIPMENT,

Locust Point, BALTIMORE. Pier No. 62, PHILADELPHIA.

Also, SOLE AGENTS for the

BRECKENRIDGE CANNEL,
OF KENTUCKY.

Within the past two years we have delivered this Cannel to over ONE HUNDRED COMPANIES IN THIRTY-THREE DIFFERENT STATES, and it is now in use in some of the large Gas Works

On the Continent and in South America,

where it successfully competes with the Australian Shale. It is the ONLY AMERICAN GAS CANNEL of sufficiently high grade to warrant EXPORTATION TO EUROPE AND SOUTH AMERICA, and it is the only economical substitute for OIL OR NAPHTHA. ONE GROSS TON will produce

10,000 Cubic Feet of 75 Candle Gas,	} equal to {	750,000 Candle Feet of Gas, and 26 Bushels of merchantable Coke weighing 900 Pounds
or 12,500 " " 60 " "		
or 15,000 " " 50 " "		

This is the ONLY GAS CANNEL that will produce a REALLY MERCHANTABLE COKE. It can be delivered in parcels of one carload or more to any point in the United States or Canada. Cargo shipments of any size required can be made from NEW YORK, PHILADELPHIA, BALTIMORE, or NEWPORT NEWS. Samples will be sent and particulars of price, etc., forwarded upon application to above address.

JAMES & WILLIAM WOOD,
Gas and Cannel Coal Contractors,

No. 40 St. Enoch Sq., Glasgow. No. 2 Talbot Court, London.

Proprietors of the BATHVILLE COLLIERIES (which produce the celebrated BOGHEAD CANNEL), Shields, Shieldmuir, Drumpeller, and other Collieries. This Firm offer

STANDARD CANNELS,

Unequaled as Gas Enrichers.

Also, WEST FAIRMONT GAS COAL, of W. Va.

Analyses, prices, and all further information furnished on application to

Agency for U. S., Room 93, Nos. 2 & 4 Stone St., N.Y. City.

The Standard Oil Company,

REFINERS OF

NAPHTHA AND GASOLINES.

ALSO MANUFACTURERS OF

A Special Grade of Naptha for
 Gas Companies

FOR ENRICHING COAL GAS.

Correspondence solicited.

No. 43 Euclid Avenue, Cleveland, Ohio.

To Gas Companies.

We make to order CAP BURNERS to burn any amount under a stated pressure. Send for samples.

Also, SERVICE CLEANERS, DRIP PUMPS, and STREET MAIN PROVING APPARATUS.

C. A. GEFROER,

248 N 8th Street, Phila., Pa.

COKE CRUSHERS.

GAS COALS.

GAS COALS.

Newburgh Orrel Coal and Coke Co.

MINERS AND SHIPPERS OF

STEAM, SMITHING, AND GAS COALS,
Foundry and Crushed Coke.

Home Office, 33 S. Gay Street, Baltimore, Md.

J. HARRY LEE, President.

Shipping Wharves, Locust Point, Baltimore.

The Despard Gas Coal Co.,

MINERS AND SHIPPERS OF

DESPARD GAS COAL,

AND MANUFACTURERS OF

COKE.

MINES, Clarksburg, Harrison Co., W. Va.

WHARVES, Locust Point, Baltimore, Md.

OFFICE, 225 E. German St., " "

ROUSSEL & HICKS, } AGENTS. } BANGS & HORTON,
71 Broadway, N. Y. } 60 Congress St., Boston.

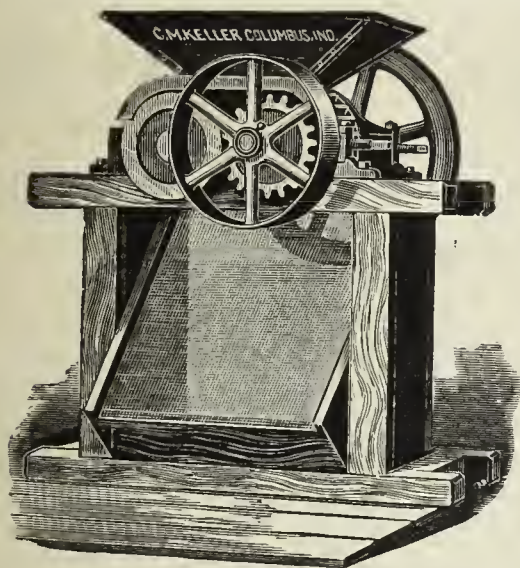

Keller's Adjustable Coke Crusher.

SIMPLE, STRONG, AND DURABLE.

C. M. Keller, Sec. & Supt. Gas Lt. & Coke Co. Columbus, Ind.

Correspondence Solicited.

King's Treatise on Coal Gas.

The most complete work on Coal Gas ever published.

Three Vols. Bound, \$30.

BOOKS.

DISTILLATION OF COAL TAR AND
AMMONIACAL LIQUOR.

By GEORGE LUNGE. Price \$12.50.

A TREATISE ON THE COMPARATIVE
COMMERCIAL VALUES OF GAS
COALS AND CANNELS.

By DAVID A. GRAHAM. 8vo., Cloth. Price \$3.

Orders for these books may be sent to this office.

A. M. CALLENDER & CO.,

42 PINE ST., N. Y. CITY

THE
PENN GAS COAL CO.

OFFER THEIR

Coal, Carefully Screened & Prepared for Gas Purposes.

Their Property is located in the Youghiogheny Coal Basin, near Irwin and Penn Stations on the Pennsylvania Railroad, and on the Youghiogheny River.

Principal Office:

209 SOUTH THIRD STREET, PHILA., PA.

Points of Shipment:

Pennsylvania Railroad Piers; Greenwich Wharves, Delaware River; Pier No. 1 (Lower Side), South Amboy, N. J.

Chesapeake & Ohio Railway Coal Agency,

FOR THE SALE OF THE

Superior Kanawha Gas Coals, Cannelton Cannel,
Also, **SPLINT AND STEAM COALS**

From the Kanawha and New River Regions, on the line of the Chesapeake & Ohio R'way.

C. B. ORCUTT, General Agent, - - No. 1 Broadway (Room 217) New York City.

FRANCIS H. JACKSON, Prest. EDMUND H. McCULLOUGH, V.-Prest. CHAS. F. GODSHALL, Treas. H. C. ADAMS, Sec.

THE WESTMORELAND COAL CO.

Chartered 1854.

Mines situated on the Pennsylvania and the Baltimore and Ohio Railroads, in Westmoreland County, Penn.

POINTS OF SHIPMENT:

PHILADELPHIA, BALTIMORE, SOUTH AMBOY, N. J.,
WATKINS (SENECA LAKE), N. Y.

Since the commencement of operations by this Company its well-known Coal has been largely used by the Gas Companies of New England and the Middle States, and its character is established as having no superior in gas-giving qualities, and in freedom from sulphur and other impurities.

Principal Office, 224 South 3d St., Phila., Pa.

The American Gas Engineer
and Superintendent's Handbook.

By WILLIAM MOONEY.

Consisting of Rules, Reference Tables, and Original Matter
Pertaining to the Manufacture, Manipulation, and
Distribution of Illuminating Gas.

350 Pages, Full Gilt Morocco.

\$3.00.

A. M. CALLENDER & CO., 42 Pine St., N. Y.

GAS METERS.

GAS METERS.

GAS METERS.

JOHN J. GRIFFIN & CO.,

Nos. 1513, 1515, 1517 & 1519 Race Street, PHILADELPHIA.

52 Dey St., NEW YORK.

75 N. Clinton St., (FRED. R. PERSONS, Mangr.) CHICAGO.

MANUFACTURERS OF

METERS FOR MEASURING GAS

IN ANY VOLUME.

Provers, Gauges, Registers, Etc, Etc.

EXPERIMENTAL APPARATUS FOR QUANTITATIVE AND QUALITATIVE ANALYSIS.

Careful and Prompt Attention paid to Repairing of all kinds of Meters and Apparatus.

Estimates Cheerfully Furnished.

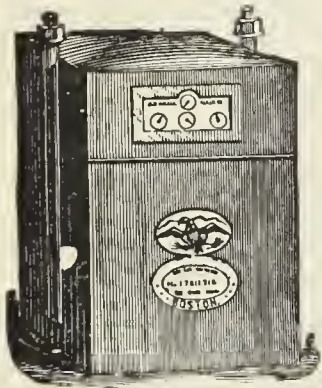

Dry Gas Meters.

With 40 years' experience and the best facilities for manufacturing, is enabled to furnish reliable work and answer orders promptly.

NATHANIEL TUFTS,

No. 153 Franklin Street, Boston, Mass.,

MANUFACTURER OF

DRY GAS METERS.

Station Meters of any Capacity.

Test and Experimental Meters, Pressure Registers, Pressure Gauges, Pressure and Vacuum Gauges.

METER PROVERS, PHOTOMETERS, STREET LANTERNS, ETC., ETC.

Patent Cluster Lanterns for Street Illumination.

HAROLD J. BELL.

BELL & JONES,

S. LEWIS JONES.

No. 12 North Ninth Street, Philadelphia, Pa.

Works at Royersford, Pa.

MANUFACTURERS OF

GAS METERS, STATION AND EXPERIMENTAL METERS,

Meter Provers, Pressure Gauges, and All Other Gas Appliances in Our Line.

WE REPAIR ALL KINDS AND MAKES OF METERS, AND THE WORK GUARANTEED.

High Pressure Meters for Natural Gas, in Iron Cases, guaranteed to stand 300 lbs. Pressure.
Gas Cooking and Heating Stoves, Hot Plates, Cake Griddles, Waffle Bakers, Boiling Stoves, Laundry and Tailors' Iron Heaters. Hotel and Cafe Ranges a Specialty.

Correspondence Solicited.

Estimates Furnished.

SCIENTIFIC BOOKS.

All books forwarded by express, upon receipt of price; if sent by mail, postage must be added to price given. We take pains in forwarding any other Works desired. Remittances by check, draft, or P.O. money order.

KING'S TREATISE ON THE MANUFACTURE OF COAL GAS. Three vols; \$10 per vol.	COAL; ITS HISTORY AND USE, by PROF. THORPE. \$3.50.	A TREATISE ON THE COMPARATIVE COMMERCIAL VALUES OF GAS COALS AND CANNELS, by D. A. GRAHAM. 8vo. Cloth. \$3
GAS MANUFACTURE, by WILLIAM RICHARDS. 4to., with numerous Engravings and Plates, in Cloth binding. \$12.	THE GAS WORKS OF LONDON, by COLBURN. 60 cents.	GAS COMPANIES DIRECTORY. \$3.
TECHNICAL GAS ANALYSIS. \$3.00.	THE GAS FITTER'S GUIDE, Showing the Principles and Practice of Lighting with Coal Gas, by JOHN ELDRIDGE. 40 cents.	GAS VERSUS ELECTRIC LIGHT. 50 cents.
GAS CONSUMER'S GUIDE. \$1.	MUNICIPAL LIGHTING, by F. H. WHIPPLE. \$1.	THE AMERICAN GAS ENGINEER AND SUPERINTENDENT'S HANDBOOK, by Wm. MOONEY. \$3.
A GUIDE TO GAS LIGHTING. 40 cents.	GAS WORKS, AND MANUFACTURING COAL GAS, HUGHES. \$2.20.	DIGEST OF GAS LAW. \$5.
GAS MEASUREMENT AND GAS METER TESTING, by F. W. HARTLEY. \$1.60.	THE MANAGEMENT OF SMALL GAS WORKS, by C. J. R. HUMPHREYS. \$1.	GAS ENGINE INDICATOR DIAGRAM, by W. E. AYRTON. Paper. 20 cents.
GAS CONSUMER'S HANDBOOK, by WILLIAM RICHARDS, C.E.; 18mo., Sewed. 20 cents.	MANUAL FOR GAS ENGINEERING STUDENTS, by D I E E. 40 cents.	TESTING PIPES AND PIPE JOINTS, by M. M. PATERSON. 80 cents.
A PRACTICAL TREATISE ON GAS AND VENTILATION, with Special Relation to Illuminating, Heating, and Cooking by Gas, by E. E. PERKINS. \$1.25.	HOW TO MANAGE GAS, by F. WILKINS. Paper. 20 cents.	DESIGNING WROUGHT AND CAST IRON WORK, by H. ADAMS. Paper. Three parts, 60 cents each.
PRACTICAL TREATISE ON HEAT, by THOMAS BOX. Second edition. \$5.	THE DOMESTIC USES OF COAL GAS, AS APPLIED TO LIGHTING, by W. SUGG. \$1.40.	NOTES IN MECHANICAL ENGINEERING, by H. ADAMS. \$1.
	DISTILLATION OF COAL TAR AND AMMONIACAL LIQUOR, by GEO. LUNGE. New Edition. \$12.50.	STRAINS IN IRONWORK, by H. ADAMS. With plates. \$1.75.
	ILLUMINATING AND HEATING GAS, by W. BURNS. \$1.50.	GAS WORKS--THEIR ARRANGEMENT, CONSTRUCTION, PLANT, AND MACHINERY. \$8.

A. M. CALLENDER & CO., 42 Pine Street, New York.

GAS METERS.

GAS METERS.

GAS METERS.

GEO. J. MCGOURKEY, Prest.

WM. H. MCFADDEN, Vice-Prest. (Phila.)

WM. N. MILSTED, Gen. Supt. and Treas. (New York).

WM. H. DOWN, Sec.

THE AMERICAN METER CO.

WET AND DRY GAS METERS.

PRESSURE REGISTERS.

METER PROVERS.

STATION METERS.

PRESSURE & VACUUM REGISTERS.

PORTABLE TEST METERS.

EXHAUSTER GOVERNORS.

PRESSURE & VACUUM GAUGES.

EXPERIMENTAL METERS.

DRY CENTER VALVES.

CRESSON GAS REGULATORS.

AMMONIA TEST METERS.

GOVERNORS FOR GAS WORKS.

MARSLAND WATER METERS.

BAR & JET PHOTOMETERS.

Manufactories:

512 West 22d St., N. Y.

Arch & 22d Sts., Phila.

GAS STOVES.

SUGG'S "STANDARD" ARGAND BURNERS,

SUGG'S ILLUMINATING POWER METER,

Wet Meters, with Lizar's "Invariable Measuring" Drum.

Agencies:

177 Elm Street, Cincinnati.

214 & 216 N. Wells Street, Chicago.

510 North Second Street, St. Louis.

222 Sutter Street, San Francisco.

HELME & McILHENNY,

(Established 1848.)

CAS METER MANUFACTURERS,

Nos. 1339 to 1349 Cherry Street, Philadelphia, Pa.,

WET AND DRY GAS METERS, STATION METERS, EXPERIMENTAL METERS, METER PROVERS,

Center Seals, Pressure Registers, Governors, Indicators, Photometers, and all other kinds of Apparatus for use in Gas Works.

FOULIS' PATENT STATION AND DISTRICT GOVERNORS.

REPAIRING DEPARTMENT.—We employ a special force of skilled workmen repairing meters of all makers.

WM WALLACE GOODWIN, Prest. and Treas.

WM. H. MERRICK, Vice-Prest.

S. L. JONES, Sec.

S. V. MERRICK, Supt.

THE GOODWIN GAS STOVE AND METER CO.,

Successors to W. W. GOODWIN & CO.

1012, 1014 and 1016 Filbert St., Phila., Pa.

142 Chambers St., New York City.

76 Dearborn, St., Chicago, Ills

WALDO BROTHERS, Agents, 88 Water Streets, Boston, Mass.

MANUFACTURERS OF

DRY AND WET GAS METERS,

Station Meters (square, cylindrical, or in staves), Glazed Meters, King's and Sugg's Experimental Meters, Lamp Post Meters, etc., etc. Meter

Provers (sizes 2, 5, and 10 feet), Pressure Gauges of all kinds, Pressure Registers, Pressure and Vacuum Registers, Pressure Indicators

(sizes 4, 6, and 9 inch), King's Pressure and Vacuum Gauges, Dry and Wet Center Seals, Dry and Wet Governors, Exhauster

Governors, Photometers of all descriptions. Letheby's Sulphur and Ammonia Test Apparatus complete. Also, Testing

and Chemical Apparatus of all kinds, and of the most perfect description, for all purposes relating to Gas.

Manufacturers of the "SUN DIAL" GAS STOVES, for Cooking and Heating.

Goodwin's Improved Lowe's Jet Photometer.

Agents for Bray's Patent Gas Burners and Lanterns.

Special attention to Repairs of Meters and all Apparatus connected with the business. All work guaranteed first-class in every particular. Orders filled promptly.

G. B. EDWARDS, Manager, New York.

S. S. STRATTON, Manager, Chicago.

D. McDONALD & CO.,

GAS METER MANUFACTURERS.

(Established 1854.)

51 Lancaster St., Albany, N. Y.

34 & 36 West Monroe St., Chicago, Ill.

STATION METERS, EXPERIMENTAL METERS, METER PROVERS, PRESSURE & VACUUM REGISTERS, PRESSURE GAUGES, ETC

Also STAR GAS STOVES, RANGES, and HEATING STOVES.

We use only the very best materials, and employ the most skilled labor, and by our long experience (32 years) and personal supervision of every detail, we feel justified in assuring the public that our goods will give perfect satisfaction. Every Meter emanating from our establishment will bear the State Inspector's Badge, and will be fully warranted by us. Our Annual and Calendar will be sent to Gas Companies upon application.

GAS INTO POWER,

BY THE

OTTO GAS ENGINE.

GAS POWER.—A Source of Revenue to Gas Companies ready to engage in Electric Lighting, building of Water Works, Electric Street Railways, etc.

Coal for producing Gas is less in amount than that for producing Steam, both being measured on an equal amount of work performed. And, further, with Gas,

50 to 90 per Cent. of Value of Coal is Returned

by sale of Coke and Tar, according to the market value of these products.

Labor for handling fuel is reduced, by its becoming centralized and confined to the gas house, and frequently has not increased after the addition of a power station.

With Gas Power, cost of fuel is strictly limited to the time of use.

MANY VALUABLE
AND RECENT
IMPROVEMENTS.

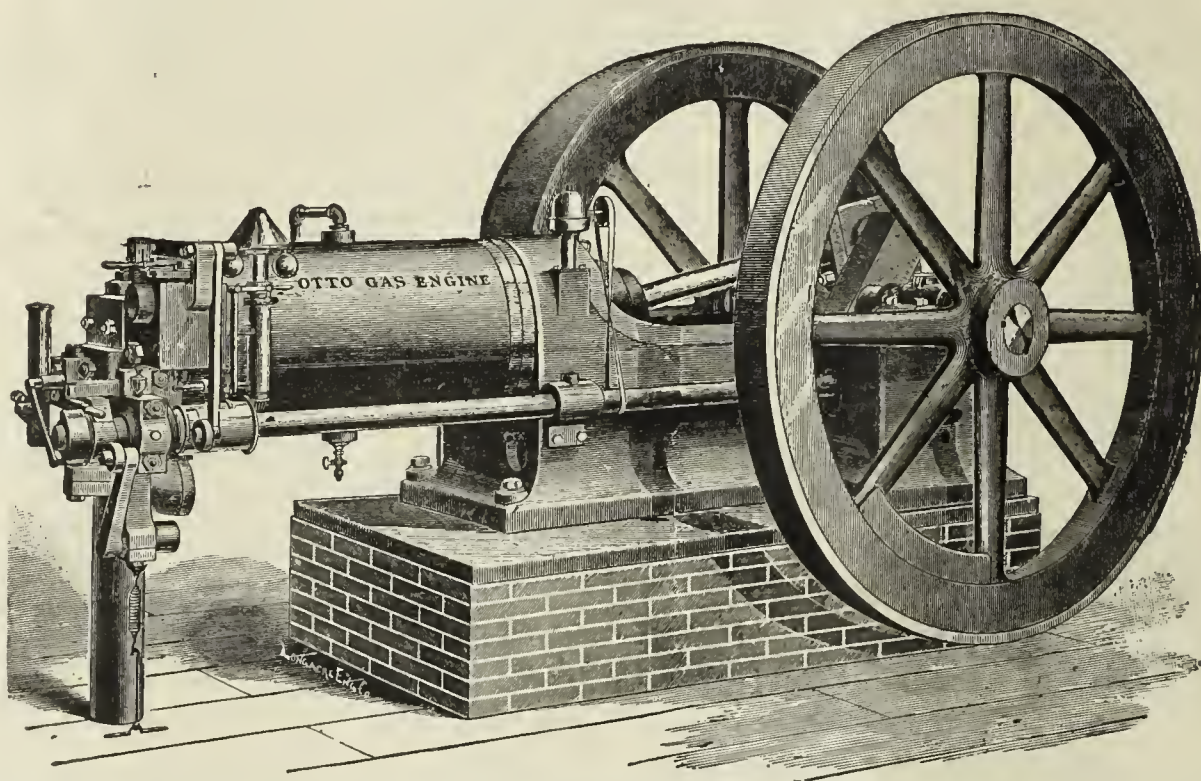

SIZES,
1-3 to 100
HORSE POWER.

Wherever Gas Companies tried Gas Power with Steam Power together in one Station, the use of Steam was subsequently abandoned or restricted, and Gas Power made to take its place.

Where Gas Companies adopt Gas Power for Electric Plants, Water Works, Sewerage, etc., they not only choose the most economical power for their use, but secure to themselves the numerous advantages of increased production, without increase of expense, and benefit thereby their entire manufacture. They induce consumers, by their example, to abandon Steam for Gas Power, and, by establishing special rates, make

Gas Power the Leading Power of To-Day,
AND SOLVE AT ONCE THE QUESTION OF FUEL GAS.

“Otto Gas Engine Works,”

SCHLEICHER, SCHUMM & CO.,

151 Monroe St. (Kent Building), Chicago.

33d & Walnut Sts., Phila.

NEW YORK AGENCY, 18 VESEY STREET.

THE AMERICAN

GAS LIGHT JOURNAL

REDMAN & KENNY, N. Y.

PUBLISHING OFFICE No. 42 PINE STREET

DEVOTED TO THE INTERESTS OF ILLUMINATION, VENTILATION, WATER SUPPLY AND DISTRIBUTION, & GENERAL SCIENCE.

VOLUME LII.—No. 13.
Whole No. 773.

NEW YORK, MONDAY, MARCH 31, 1890.

{ \$3 PER ANNUM,
IN ADVANCE.

A. M. CALLENDER & CO., Proprietors. C. E. SANDERSON, Manager.
JOS. R. THOMAS, C. E., Editor. T. J. CUNNINGHAM, Asst. Editor.

ENTERED AT THE POST OFFICE AT NEW YORK, N. Y.
AS SECOND CLASS MATTER.

Published on each Monday of the year, at No. 42 Pine Street, N. Y.

Terms of Subscription, including Postage.—For the United States and Canada, \$3 per annum. European countries, \$4.50 (19 shillings—22½ francs). All payments to be made in advance. Single copies, 10 cents.

Remittances should be made either by post-office order, registered letter, or bank draft on New York, payable to the order of A. M. Callender & Co.

Collections are invariably made directly from this office, for subscriptions, advertisements, etc. We have agents to solicit the same, but they are not authorized to receipt for money.

Correspondence.—Wishing to make this JOURNAL a gazette of intelligent discussion to those of our readers who may wish to gain or give information on the subjects to which its columns are devoted, correspondence is solicited for publication from all who make the study of those subjects a pleasure or a profession.

The American News Company, Nos. 39 and 41 Chambers street, New York, are agents for this JOURNAL. Newsdealers will send orders to them.

CONTENTS.

An Asterisk (*) denotes an illustrated article.

EDITORIALS—

Briefly Told..... 425
The Toledo Convention—A Banquet Response—The Wakefield Manufacturing Company—Repealing the Carbonic Oxide Act—Mr. C. P. Greenough's Argument—Notes.

An Interesting Chapter in Photometrical Testing, and an Addendum, by T. S. Clemminshaw..... 427

The Three-Lift Holder at Dawsholm Station of the Glasgow Corporation Gas Works..... 427

*Device for Charging Inclined Gas Retorts..... 428

An Argument in Favor of the Municipal Ownership of Electric Lighting Plants..... 429

Sixth Annual Meeting, Ohio Gas Light Association.—Official Report—Revised by the Secretary..... 431

First Day, Morning Session: Report of Executive Committee—Report of Committee on Legislation—Annual Report of Secretary—Letters of Regret—Election of New Members—Report of Treasurer—Roll Call—Report of Finance Committee—Appointment of Committees

*Alavoine's Gas Washer..... 433

Special English Correspondence..... 434
Gas Managers' Spring Meetings—The Institution of Gas Engineers—Van Steenberg's Carbureted Water Gas.

ITEMS OF INTEREST FROM VARIOUS LOCALITIES..... 435

The Consolidation at Batavia, N. Y.—Calling the General Down—Mr. Fitch Takes Hold of the Sherman (Tex) Works—Annual Election, Bay State Company—Improvements at Detroit, Mich.—New Hands in Control at Joplin and Carthage, Mo.—Another Superintendent for Saratoga Springs, N. Y.—A Hint from Madison, Wis.—Mr. Anderson to Take Charge at East Boston, Mass.—Changes at Salt Lake City—Advices from Australia—Damage Suit—And Many Other Items.

Recent Patent Issues..... 437

The Market for Gas Securities..... 437

BRIEFLY TOLD.

THE TOLEDO CONVENTION.—Perhaps it would seem unnecessary, in view of the extended telegraphic report forwarded us by "Three Stars," and printed in our issue for last week concerning the proceedings of the Toledo gathering of the Ohio Association, to say anything further about it; but it is likely that a word or two more will not come amiss. Broadly it may be stated that the meeting was a most successful one, and to President Lindsley's tact the Association is in no small degree indebted for that happy result. Although the paper list was rather less on the large numerical order than formerly, the plethoric question-box more than made up the requisite quantity of material for food-thought. In fact, had the paper list been larger the Association might have been embarrassed in its riches. As it was, out of the eight papers listed seven were read—the omitted one was that to have been contributed by Jos. M. Bate, of Canton, who reported by telegraph that he was detained at home because of a "fight" then on in his bailiwick between gas, electric light and kerosene oil—and these were supplemented by two others (one by Mr. M. A. Gemunaer, and the second by Mr. A. R. Foote), which were read in connection with Mr. Wilkiemeyer's remarks on the "Municipal Control of Lighting." Regarding the latter, we have only to say that "Three Star's" opinion of the value of Mr. W.'s paper but does him simple justice. We had hoped that Mr. Evan's would have given us something of a different nature in his record of "Another Year with Fuel Gas;" for from his Jackson experience, as gathered in the working of another twelve-month, fact and fancy ought now to be easily determined, at least in respect to the intrinsic merit of the fuel gas plan which is in fashion there. Apart from his comparisons in respect to the relative fuel value of illuminating gas and fuel water gas—and we imagine that his deduction that "illuminating gas as used for cooking and heating is worth but 30 per cent. more than fuel water gas, instead of 2½ times as much," will find but few indorsers—we would like to reply in answer to the following plaint of Mr. Evans—"I was painfully surprised to learn the opinions of some of the success of our Jackson plant, especially so in this case, because I am positive that the engineers in question never were in Jackson to investigate the system in use, but were only too willing to cry down something they knew nothing about"—that those, in this section of the country at least, who are most outspoken against the Jackson method, are the ones who have visited Jackson for the purpose of examining the system with a view to installing the system in their home situations, did it, in their opinion, even fairly meet the conditions under which it would have to be tried. The increased business of the fuel gas company at Jackson, Mich., is a very slender thread whereon to suspend the success of its lighting and fuel gas supply. The Company has the entire field to itself, and its business ought to grow, and "the fate" (to quote from the Evans paper) "of the now defunct Jackson" (or old Company) "Gas Light Company" is the common fate of all corporations whose proprietors part with their property in consideration of having received a good price therefor. It is time that the fact was plainly stated that the old Jackson Company was not driven from the field; it was bought and paid for by those whose interests would be subserved in the purchase. It may be taken for granted, however, that other experiments than those at Jackson will be required ere the ques-

THE GAS WORKS SAFE AT LOUISVILLE, KY.—The following is in reply to a telegram sent to Mr. A. H. Barret, Engineer of the Louisville Gas Company: "Everything and everybody safe and sound. Works and holders about two blocks out of line of tornado."

tion of fuel gas shall have even been partially solved; and it is not asserting too much to say that many an anxious eye is looking toward Louisville, where service and not interest colors the policy of those in charge of the experiment of supplying fuel water gas.

THE Association is to be congratulated on the excellent exhibition of gas cooking apparatus, etc., that was held under its auspices. It was most successful, and the arrangement of the showroom was worthy of all praise. The display will bear fruit in the sendout of many an Ohio city and town the coming summer, and the manufacturers will also share in the reward that the gas makers shall reap. The visit to the Central Chandelier Company's showrooms and factory was made in a rather desultory sort of way, but those who availed themselves of the privilege thus afforded were well repaid for their effort. The inspection of the Toledo Gas Company's properties was more generally shared in by the members, and we can dismiss this portion of the entertainment in the remark that the works are a credit to the Company, and are unmistakable evidences of the energy and capacity of its engineer.

The banquet tendered the Association and its guests by the Toledo Company was a most enjoyable affair. If President Lindsley was a success as a presiding officer, he was just as successful as a toastmaster, for certainly he left nothing to be desired in his direction of either. The toasts and responses were in happy frame and not a little of the glow of the occasion can be traced to the wit and brilliancy of Fred. R. Persons. In conclusion we have only to say that the Ohio's Sixth Annual was in all respects a success.

A BANQUET RESPONSE.—The toast at the Ohio banquet to the "GAS JOURNALS" was responded to by Mr. G. A. Hyde, of Cleveland. His handling of the subject is so well worthy of spreading before the fraternity that we herewith reproduce it in full—a glance at the roll call, which will be found elsewhere in this issue, will serve to enlighten the reader unfamiliar with the names referred to by Mr. Hyde.

"Had I the freedom of thought and flow of language of my illustrious brother, Capt. Harry White, or my distinguished and genial friend, Geo. Shepard Page, I could carry my impromptu speech in my head, and at my will and pleasure let it flow out onto my eager and attentive auditors; but my impromptu response is written and is offered for your consideration.

"About gas works, journals are portions of engines, shafting and exhausters, and a *Page* in the AMERICAN GAS LIGHT JOURNAL volunteers the information that they are a necessary part of the "Standard" washer-scrubbers used in gas works.

"The public *Journals* are the great and mighty disseminators of knowledge, truth and error, educating the people, forming public opinion, and recording passing events. The AMERICAN GAS LIGHT JOURNAL is the *Callender* of the best thought and transactions of the Gas Associations of America.

"If you are seeking *Light*, you will make no mistake if you consult the GAS JOURNAL, or go to Dayton.

"If you *Felt* that you were not *Strong* enough to make a success of your chosen profession, and were rather *Green* in the gas business, and *Wood* require a *Starr* to guide you along the uncertain *Track*, you should then consult the GAS JOURNALS.

"If you wish to know what's *Butterworth*, consult the GAS JOURNALS.

"If you desire to go fishing, and are *Spinning* about to find a *Birch* rod and *Bate*, the GAS JOURNALS will point you to the *Dell* where they can be found.

"If you wish to find the *Bird* that *Blinks* in the *Bowers*, or the *Crane* that *Hydes* in the *Hedges*, consult the GAS JOURNALS.

"If you are making investigations to ascertain the numerous products of the deep wells of Ohio, and desire to know which is the *Salter*, consult the GAS JOURNALS.

"The *Walker*, the *Turner*, the *Taylor*, and every other *Christian* brother, members of this grand Association from *Alexander* to *Zimmermann*, should, for their pleasure and profit, read and consult the *Printz*, the GAS JOURNALS.

"Now, my brother, fill your *Cantine*, but remember your failings and drink moderately; do *Credit* to this Association and go home sober, or else you may be gathered in by a *Kopp*.

"Many a gas man *Burns* his fingers through ignorance of the subject engaging his attention; but he *Can*, by consulting the GAS JOURNALS, escape such disagreeable results."

THE WAKEFIELD MANUFACTURING COMPANY.—On Wednesday, March 19th, there was introduced into the lower house of the Rhode Island Legislature a bill for the amendment of an act which seeks to

incorporate "The Columbian Land Company," the amendment being in the nature of granting to J. Edward Addicks, Samuel Little and others, the right to establish and operate gas works in the cities of Providence and Pawtucket, under the corporate title of the Wakefield Manufacturing Company. This is not in reality a brand-new measure, as one quite similar to it was "indefinitely postponed" at the May meeting of the Legislature. The bill, as said before, was presented to the lower branch on March 19th, was at once referred to the House Committee on Corporations, who reported it back on March 20th, when, under suspension of the rules, it was adopted without debate and forwarded to the Senate, which branch at once referred it to the Committee on Corporations. When the bill was considered in this Committee, its radical provisions were of such a nature that the Committee decided not to report it, but to subject it to the fullest investigation that wide publicity could assist. Accordingly, last Friday was named as a day for a hearing, the result of which we cannot ascertain in time for publication in this issue. Briefly stated, the bill authorizes the grantees to make and sell gas in Providence and Pawtucket without the preliminary (other than filing a bond of \$25,000 with the treasurer of each city) of securing the right to open and occupy the streets, from the local authority. In fact, the latter would have no more control over the doings of the Wakefield Manufacturing Company than, for instance, would the Mayor or Council of Chicago. The Wakefield proprietors are also authorized to "purchase, own, hold and dispose of the shares of capital stock of corporations in this State and in other States, and bonds and other securities of such corporations, provided, however, that nothing in this Act contained shall be so construed as to authorize said Wakefield Manufacturing Company to carry on a banking or stock brokerage business." In other words, the proposed Act is simply an omnibus license to the grantees to harrass the capital now invested in gas works in the cities named, and to prevent the local authorities from interfering in any way in the proposed spoliation. We hope that the good sense of the Rhode Island Senate will incline to protect Rhode Island capital from the clutches of this syndicate, who, wherever they have gained a foothold, have made cheap gas a slim possibility. In the meantime, we note that Mr. Addicks is now endeavoring to freeze out the stockholders of the old Wilmington (Del.) Gas Company, by virtue of the omnibus charter granted him by the Legislature of that State, and under which he proposed to "construct and operate" gas works in that city. We shall keep our readers posted in respect to the history of the proposed Rhode Island grab.

REPEALING THE CARBONIC OXIDE ACT.—The Committee on Manufactures, of the Massachusetts State Legislature, have presented a unanimous report recommending the removal of all restrictions as to the percentage of carbonic oxide that may be contained in illuminating or heating gas distributed in that State.

WE are in receipt of a copy of the argument recently made by Mr. C. P. Greenough, as counsel for remonstrants, before the Committee on Manufactures, of the Massachusetts Legislature, on the proposed bill to enable cities and towns of that State to supply, sell and distribute illuminating gas, etc. The argument is in masterly vein, and bristles with telling points, tersely told. The grouping of the statistics is admirably done, and we make no doubt that the well-trained lawyer will receive many inquiries for copies of his argument.

WE note that the ship *Belt* sailed last Friday from Newport News with a cargo of 1,734 tons of Breckenridge cannel for Rio de Janeiro. The shipment, of course, was made under direction of Messrs. Perkins & Co., of this city.

IT having been reported that Mr. Emerson McMillin was about to resign the Presidency of the Laclede Gas Company, we desire to say that the statement is a mere fabrication.

AN application has been filed for a charter for the operation of the Tuscaloosa (Alabama) Gas, Electric Light and Power Company, the incorporators of which have already secured by purchase the local electric light works. The Company is officered as follows: President, Geo. A. Search; Secretary and Treasurer, Jhon A. Daniel; Directors, Geo. A. Search, Robert Jenison, J. F. B. Jackson and W. Fitts.

A BILL has been introduced in the New York Legislature which seeks to establish the following maximum rates for gas in this State: In cities whose population is over 100,000 but under 500,000, \$1.75 per 1,000; between 500,000 and 1,200,000, \$1.25 per 1,000.

[COMMUNICATED ARTICLE.]

An Interesting Chapter in Photometrical Testing, and an Addendum.

By MR. T. S. CLEMINSHAW, Engr. Launceston Gas Company, Tasmania.

Whilst perusing Mr. W. J. Dibdin's excellent book on "Practical Photometry," it occurred to me that the question of gas-testing candles was scarcely exhausted, and with the hope that my experience may be worth recording in your issue I write this.

Having a large stock of gas-testing candles here when I first came, I thought they should be worked out before a fresh supply was ordered, and as soon as the new candles arrived (before the old stock was done) experiments were at once instituted in order to ascertain whether the abnormally high returns on the Evans photometer were correct or not.

The gas supply to the photometer room is derived from a special service laid on to a pressure register, and travels but a short distance from the 18-inch governor. The holder was not changed during any of the experiments, so as to avoid any chance of error from that source.

many gas engineers who, like myself, are their own gas examiners. Till then we must content ourselves with the standard means of testing, which takes an hour each time.

ADDENDUM.

I note in your issue of Jan. 6, 1890, page 3, that Mr. F. Egner, having been troubled by mineral oil in his exhauster, was driven to use lard oil. I called attention to this same matter in your esteemed paper* some years ago, and found my way out of the difficulty by using castor oil.

I have two Gwynne exhausters (10,500 feet per hour size), coupled, running with castor oil beautifully; and in the winter a Donkin (25,000 feet per hour size), running with "Globe" oil—a mineral oil—also beautifully; and yet if I use Globe oil on the two smaller exhausters they will stick me up in 24 hours. The black varnish which Mr. Egner speaks of was always present when the two exhausters were "stuck up."

The 25,000-ft. exhauster ran night and day for six months, at 65 rev-

Results of Photometrical Testings.

Folio.	Date, 1889.	Uncorrected.			Corrected Average of Three Tests.	Rate of Average Consumption of Candles. Grains.	Remarks.
		1st Test.	2d Test.	3d Test.			
170	Friday, May 10....	19.76	19.95	20.13	41.75	Old candles; gas from street.
171	Saturday, " 11....	19.51	19.77	20.53	20.22	41.1	Old " gas from experimental holder.
172	" " 11...	18.19	18.12	17.55	18.22	40.1	New " " " "
174	Sunday, " 12....	17.72	17.79	17.65	17.72	40.5	New " " " "
176	" " 12....	18.60	18.05	18.87	18.51	39.6	Old " " " "
180	Thursday, " 16....	20.47	20.26	19.47	20.00	40.3	Old " " " "
181	" " 16 ...	18.78	18.77	18.49	18.31	39.6	New " " " "

MEMO.—It is a point sometimes made against the Evans closed-in photometer that the readings show a perceptible rise toward the third testing. I append the following tests to show that the difference, in my experience at least, is not so very great as could be imagined:

Folio.	Actual Observations		
	1st.	2d.	3d.
235.....	18.38	18.17	18.17
236.....	19.38	19.85	19.57
237.....	19.18	19.39	19.08
239.....	18.98	18.98	18.75
240.....	17.60	18.32	18.05
241.....	18.18	18.76	18.81
242.....	18.84	18.66	18.82
243.....	18.50	18.27	18.54
192.....	18.09	18.04	18.04

It will be seen that the apparently high power of the gas dropped at once when the new candles were employed; and this only confirmed my suspicions, and led me to infer that the candles had suffered from being kept so long (in a dry place), it being nearly 8 years since they left the maker's hands. There is no instruction as to the age of candles in the Referees' instructions. The photometer is an Evans closed-in pattern, and the usual method of testing employed is that given in the Referees' instructions.

In Mr. Dibdin's book (page 92) we read: "Whilst candles are, no doubt, unsatisfactory as a standard, they are not, when properly made and used, so bad as many of the published results have caused them to appear."

Again (on page 122), read: "The day cannot be far distant when a worthy substitute for the discredited candles will be found, and then those who deem them an excuse for the present neglect will never recover their lost ground."

Taking these two passages together, one is apt to be more distrustful than ever in candles as a standard for testing gas, and my only consolation lies in the probability that these two paragraphs were written at different times, with some long interval between, and that the writer must have suffered disappointment from the use of unsatisfactory candles when the last paragraph was penned.

I feel sure that the adoption of a perfectly reliable means of testing gas, in a few minutes, will be hailed with the greatest satisfaction by

olutions per minute, and only stopped twice, to pack the engine glands; so that there is some reason for sticking up other than the pitchy substance alone. It must have something to do with the internal construction of the exhauster.

[From Engineering.]

The Three-Lift Holder at Dawsholm Station of the Glasgow Corporation Gas Works.

Besides the extensions carried out during last year at the Tradeston Works, and which have already been described in our columns, an addition was made to the gasholder capacity at Dawsholm Works by adding a third lift to one of the existing gasholders. This work was executed by Messrs. Clayton, Son & Co., Limited, Hunslet, Leeds. It must, of course, be borne in mind that Mr. Foulis in this instance had not a free hand. To use a well-known Scotch saying, he had to "cut the coat to suit the cloth." The details of the design were regulated to a large extent by the existing holder, so that it must not be forgotten by the reader that the third lift was an addition to the holder built sixteen years ago. That the adaptation of the third lift to the old structure is admirable will be made evident by an examination of the plans, and to many the fact that it is only an addition may render the work more interesting.

The total height is slightly over 125 ft., including the depth of the tank, which is 30 ft. under the ground level. The depth of each of the lifts is about 30 ft. The diameter of the tank is 163 ft., while the diameters of the outer, middle, and inner lifts of the gasholder are respectively 160 ft., 157 ft. 8½ in., and 154 ft. 6¾ in. The original framing consisted of sixteen cast iron columns 65 ft. high, 3 ft. in diameter at bottom, tapering to 2 ft. 6 in. at top, tied together at top by lattice girders, and having guide runs bolted by distance brackets to the inner side of columns. These columns had to be heightened to the extent of 30 ft. For this purpose certain top pieces, caps and girders were removed, and two new lengths, each 15 ft. long and 31½ in. in diameter, were bolted to the remaining part of each column. The pieces removed with the caps and the girders were then replaced on the top of the new lengths, the joints being made by internal flanges turned true, and securely bolted by eight 1½-in turned bolts in each flange, having

* May 17, 1886, page 293.

strengthening brackets between each bolt hole. Bolted to the inner side of each column is a wrought iron lattice girder, which extends from the top of the pedestal to 18 in. above the capital of the column. The outer and inner members of those girders are formed of two angle irons 4 in. by 3½ in. by ½ in., with diagonal bars 2 in. broad and ⅝ in. thick riveted between them. The angle irons of the inner members are set to suit the curve of column, and firmly bolted thereto. The guide runs, which are of channel iron 5 in. by 3 in. by ½ in., are fixed to the lattice girder by bolts with countersunk heads.

Besides the top row of girders, two additional rows of girders were constructed at equal distances between top and bottom. These are of the lattice type, and 3 ft. deep, and of the same design as the top girders.

The top and bottom members of the girders are formed of two angle irons 4½ in. by 4½ in. by ½ in. and plates 12 in. broad and ⅝ in. thick forming flanges. Diagonal bars 4 in. broad and ½ in. thick are riveted between the angle irons. Wrought iron brackets formed of ¾ in. plates and angle irons, are bolted to the girders and columns at top and bottom of each end of the girders, and also at the base of each column. At top of each column a malleable iron strap is securely fixed, fitting tight round the column. To these brackets and straps one end of the bracing bars is secured, the other end being connected by wrought iron rings, 18 in. in diameter, with nuts and washers on the inside and outside, and over all is an ornamental plate.

In describing the holder itself we will proceed in the same way by narrating the successive steps in its construction. The covering having been removed, the top row of plates of the middle lift was cut to a breadth of 15 in., and a grip formed of ½-in steel plates bent so as to form a sort of lip, 1 ft. 8 in. deep and 1 ft. wide, having riveted to the outer edge a bar of half flat iron 1½ in. by ½ in. The design also shows an upright bar which is fixed so as to connect the grip just described with a similar arrangement at the bottom. These also serve as guides to the inner lift. The inner lift is entirely new, with the exception of the crown sheets and framing.

The top curb is formed of three angle irons and two ¾-in plates, 18 in. broad, the whole forming a continuous ring. The corner plates, which are attached to this curb, are of steel ½ in. thick bent to an appropriate curve, and strengthened by angle irons of mild steel 5 in. by 4 in. by ½ in. riveted to curb and plates, and to these angles the main principals are attached. These are made particularly strong, as against them are fixed the pulleys and their brackets.

Thirty-two semi-tubes removed from the middle lift of holder and lengthened, are fixed to the side sheets to connect the grip and top curb. The bottom of these tubes is fixed to a plate ½ in. thick and 22 in. broad, carried all round, and riveted to the bottom grip of the lift and fished at the joints, thus forming a continuous ring. The bottom row of plates next the grip and the plates at each upright semi-tube are ¼ in. thick, the row next the corner plates are ⅝ in. thick, and the row below ½ in., the intermediate rows are sheets No. 12 B. W. G. Opposite each of the upright bars of the middle lift a friction plate of cast steel is fitted to the outside of the grip of the inner lift. The plans of guide brackets and pulleys of inner, middle, and outer lifts respectively are so complete that it is not necessary to describe them at length.

The extensions of the Glasgow Corporation Gas Works which we have illustrated and described in the present and recent issues, including the principal parts of the plant needed in the manufacture and storing of coal gas, reflect the greatest credit on Mr. Foulis, who has designed them, and has himself superintended their construction.

In concluding this series of articles, descriptive and illustrative of the recent extension of the works of the Glasgow Gas Corporation, it may not be inappropriate to refer briefly to the progress made from a commercial point of view. Gas was supplied first to the citizens of Glasgow in September, 1818, by the Glasgow Gas Light Company, who continued without opposition until 1844. No record of the quantity of gas made was kept until 1827, as it was only in that year that meters were first utilized in Glasgow. In 1827 the quantity manufactured was 79,234,000 cubic feet. For two or three years the new light did not make much advance, if the make is to be regarded as a good indication of this, for in 1830 it did not much exceed 82,000,000 cubic feet. From this year onwards, however, the progress was very marked, and in ten years the quantity consumed was more than doubled, or to be precise, it was 173,863,000 cubic feet. In 1843, when a new company was organized, the consumption was about 217,000,000. The new organization of the City and Suburban Company started their works in 1844, and the effect was to greatly increase the consumption by widening the area of supply, etc. In 1844 the make was 276,500,000, 60,000,000 more than in 1843, and it increased to 333,000,000 in 1845. In 1850 the total reached

451,000,000, an addition in ten years of more than 200 per cent. The progress continued most marked, as the following figures show :

Year.	Make in Cubic Feet.	Price per 1,000 Cubic Feet.
1855.....	593,181,000.....	s. d.
1860.....	769,241,000.....	5 0
1865.....	990,094,000.....	4 2
1869.....	1,206,921,000.....	4 7

In 1869 the corporation took over the works of the companies, and it is interesting to note that the loss by leakage was 20 per cent. of the total make, and that since that time it has been at most a half of that loss. In a table appended we give statistics as to gas made by the Glasgow Gas Corporation. From this it will be seen at a glance that as the quantity of gas made increased the revenue decreased. In other words, the citizens are now consuming 600,000,000 cubic feet more per annum than they did in 1885, and yet they are paying £36,000 less for it. The figures testify to the care with which the works are managed :

Statistics as to Gas Made by the Glasgow Gas Corporation.

Year.	Quantity of Gas Made in Cu. Ft.	Price per 1,000 Cu. Ft. s. d.	Total Revenue.
1870.....	1,295,863,000.....	4 7.....	£235,701
1875.....	1,649,616,000.....	5 5.....	378,392
1880.....	1,859,582,000.....	3 10.....	341,274
1885.....	2,368,131,000.....	3 6.....	428,227
1886.....	2,442,880,000.....	3 3.....	401,306
1887.....	2,596,470,000.....	3 0.....	386,246
1888.....	2,705,444,000.....	2 10.....	383,566
1889.....	2,905,796,000.....	2 8.....	392,896

NOTE.—The gas works were transferred to the corporation in the year 1869. The price of gas is now 2s. 6d. per 1,000 cubic feet.

Device for Charging Inclined Gas Retorts.

Messrs. F. Morris and L. Van Vestraint, of England, have been granted protection by English Letters Patent (No. 16,489) for a device for charging inclined gas retorts. In noticing the apparatus the *London Journal* says: In setting inclined gas retorts, the inventors remark, they present their upper mouths at different heights, and in different vertical rows; and the present invention relates to means for charging retorts so set by the use of a shoot, which can be adjusted in length and in position in order to conduct the coal from a supply above to the mouth of any one of the group of retorts. For this purpose, at a convenient height above the highest tier of retort mouths, there is provided a frame or carriage that can be moved on rollers horizontally

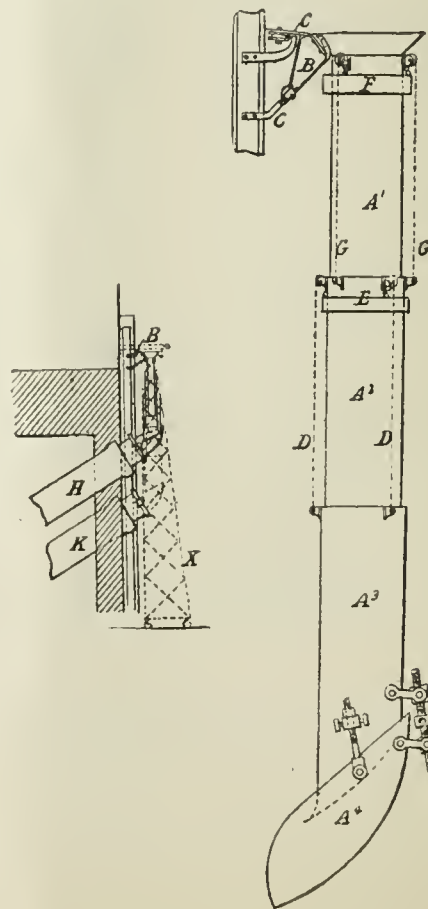

along rails; and from this carriage there is suspended a tubular shoot made in several sections, fitted to slide freely along one another like the tubes of a telescope, and balanced by weights attached to chains passing over pulleys mounted on the next higher section. When it is desired

to charge any one of the retorts, its mouth is opened, the carriage is run along the rails until the shoot comes vertically over the retort mouth, and its sections are slid telescopically until the lowest one reaches the mouth, whereupon coal can be delivered into the upper end of the shoot so as to descend into the retort.

The illustrations show portions of two inclined retorts to the charging of which a shoot, according to this invention, is applied; also an elevation of the shoot to an enlarged scale.

The shoot, as already mentioned, consists of a tube made in three lengths or sections A_1, A_2, A_3 , of which A_2 can slide freely along A_1 , and A_3 along A_2 . The highest length (A_1) is carried by a carriage B having rollers which run along rails C . The lowest length (A_3) is connected to a counterweight E by chains D passing over pulleys mounted at the upper end of A_2 ; and the length A_2 is similarly connected to a counterweight F by chains G passing over pulleys mounted at the upper end of A_1 , or on the carriage B . To the lowest section (A_3) is hinged a curved shoot A_4 , which can be adjusted so as to direct the coal as desired into the mouth of any retort. The shoot is shown in position for charging the uppermost (H) of a row of inclined retorts; the dotted lines A_3 indicating the shoot extended to charge a lower retort K . The retorts being arranged in several vertical rows, the shoot can be moved by running the carriage B along the rails, so as to come immediately above a retort in any vertical row; and it can be extended telescopically to reach the mouth of the retort.

An Argument in Favor of the Municipal Ownership of Electric Lighting Plants.

[Contributed by Mr. Victor Rosewater, of the Johns-Hopkins University, to the *Independent*.]

Questions of an economic nature are becoming more and more topics for public discussion. The people, as a whole, are gradually awakening from that lethargy in which they were willing to allow anything and everything to take its own course, regardless of the public convenience. And now, in almost every city in the country, problems of rapid transit, adequate water supply, or proper illumination of the streets, are claiming the attention of the citizens. Probably no one of the larger cities has yet done entirely away with gas for outdoor purposes; but all have, to some extent, made use of the modern substitute. From this, the importance of the question whether such lighting should be undertaken directly by the municipal authorities or should be left to private enterprise ought to be clear to every one. Consequently, any investigation which will throw the light of general experience upon the matter should prove of great value and of general interest.

Some time last fall a committee of the Council of the city of Scranton, Pa., which had been appointed to investigate the matter of electric lighting and the differences which had arisen between the city and the local company, made its report. This committee, "in order to deal intelligently with the question in hand, had deemed it wise to correspond with other cities in the United States, and to gather such data as they might have to furnish for the guidance of their deliberations." The answers received as a result of this correspondence were tabulated for more convenient perusal, and now furnish not only the most complete, but also the most reliable statistics upon the subject which have been compiled up to this time. The following table presents the figures for those cities in which arc lights were supplied by contract with private companies. All lamps are 2,000-candle power, except in Newburgh, Norwalk, Richmond, Va., Northampton, Mass., Taunton and Concord, whose lights are 1,200-candle power. The area lighted is, in every case, the entire city. In Scranton alone the radius is a factor in the cost.

Name of Place.	No. Lights.	Cost per Annum.	Hours Lighted.
Alliance, O.	8	\$144.00	All night.
Ashland, Pa.	23	125.00	All night.
Asheville, N. C.	37	100.00	2 A. M.
Adrian, Mich.	63	100.00	All night.
Atlanta, Ga.	100	120.00	All night.
Allentown	101	100.00	Except moonlight.
Akron	170	78.00	All dark nights.
Bath, Me.	27	100.00	5 all night, 22, 12 o'clock.
Battle Creek, Mich.	65	85.00	12 o'clock.
Bloomington, Ill.	211	108.00	All night.
Burlington, Ia.	39	130.00	2 A. M.
Burlington, Vt.	70	116.00	12 o'clock.
Binghamton	99	140.00	All night.
Boston	105	180.00	All night.
Cedar Rapids, Ia.	10	126.00	Except moonlight.

Chattanooga, Tenn.	30	121.66	All night.
Charleston, S. C.	35	144.00	All night.
Cortland, N. Y.	50	50.00	12 o'clock.
Columbus, Ga.	50	108.00	Except moonlight.
Concord, N. H.	39	100.00	12 o'clock.
Chillicothe, O.	121	80.00	All night.
Defiance, O.	52	60.00	
Dayton, O.	200	150.00	All night.
Eau Claire	70	110.00	All night.
Fond du Lac	36	72.00	All night.
Fall River	50	180.00	All night.
Gloucester, Mass.	13	96.00	12 o'clock.
Galesburg, Ill.	104	105.00	All night.
Galesburg, Ill.	104	69.00	12 o'clock.
Hornellsville, N. Y.	64	100.00	All night.
Harrisburg	270	90.00	All night.
Indianapolis	100	80.00	All night.
Janesville, Wis	8	100.00	Midnight.
Jacksonville, Ill.	32	100.00	Except moonlight.
Joliet	80	120.00	12 o'clock.
Jackson, Mich.	180	88.89	All night.
Keokuk, Ia.	24	126.00	Except moonlight.
Keene, N. H.	27	100.00	12 o'clock.
Lafayette, Ind.	214	50.60	All night.
Lockport, N. Y.	37	80.00	Except moonlight.
Lima, O.	58	100.00	1 o'clock.
Lancaster	139	124.10	All night.
Logansport, Ind.	75	100.00	All night.
Mansfield, O.	77	75.00	All night.
Milwaukee	130	150.00	All night.
Massillon	180	70.00	All night.
Mobile	181	91.00	Schedule moon.
Minneapolis, Minn.	480	150.00	Except moonlight.
New Britain, Conn.	66	100.00	12 o'clock.
Norwalk	82	70.00	12 o'clock.
Northampton	88	75.00	12 o'clock.
Newburgh	97	111.00	All night.
Norfolk, Va.	155	100.00	All night.
New Orleans	1,010	130.00	All night.
New York City	1,357	90.00	(Bid May 1).
Ogden	25	143.36	12 o'clock.
Pottsville, Pa.	58	105.00	All night.
Portsmouth, N. H.	60	100.00	All night.
Paterson	70	100.00	All night.
Petersburgh, Va.	82	96.00	All night.
Poughkeepsie	212	123.00	All night.
Philadelphia	800	177.00	All night.
Racine	100	70.00	All night.
Richmond, Va.	133	146.00	All night.
Reading	156	146.75	All night.
South Bend, Ind.	14	100.00	12 o'clock.
Selma, Ala.	50	120.00	Except moonlight.
St. Paul	50	127.75	Midnight.
Springfield, O.	64	130.00	All night.
Somerville, Mass.	70	135.00	1 o'clock.
Saginaw	80	100.00	3 A. M.
Sedalia, Mo.	100	87.00	Schedule moon.
Sandusky	115	100.00	All night.
Springfield, Mass.	300	83.33	All night.
Scranton	322	90.00	All night.
Taunton, Mass.	44	110.40	Schedule moon.
Terre Haute	232	70.00	3 A. M.
Troy	271	158.00	All night.
Toledo	400	100.00	All night.
Union City, Ind.	22	95.00	Except moonlight.
Vicksburg	50	114.00	Except moonlight.
Waltham, Mass.	32	127.00	1 o'clock.
Waterbury, Conn.	100	142.35	All night.
Watertown	102	68.00	1 o'clock.
Wooster, O.	30	108.00	All night.
Wilkesbarre	48	144.54	All night.
Winona, Minn.	61	125.00	All night.
Wichita	83	83.33	All night.
Yonkers, N. Y.	45	60.00	All night.
Youngstown	180	72.50	All night.
Zanesville, O.	140	70.00	Except moonlight.

One need not have much knowledge of the subject to ascertain, by

glancing at these figures, that the charges do not conform to the cost of production. The predominance of even figures would point to a merely arbitrary rate, while the partiality shown for a charge of \$100 seems to indicate a desire on the part of the electric lighting companies to keep their books in the most simple manner. Where an odd figure is to be found, it may easily be inferred that the authorities and the company originally failed to come to an agreement. But the company, with great condescension, must have granted a reduction, or offered to "split the difference," to which fact may be assigned the frequent form of $2\frac{1}{2}$ or $3\frac{1}{2}$.

A great imposition may be discerned in the relative charges for large and small numbers of lights. In the 5 cities consuming the largest number of lights the average cost is far above that in the 5 cities consuming the smallest number. That something is radically wrong must be apparent. By one not initiated in the mysteries of city contracts the very opposite would be expected. And if the charges were governed by the cost of production, that is what the statistics would show. Every increase in the number of lights is made at a less than proportionate increase in expenditure. The capacity of the plant may be doubled without doubling the investment. This is the primary characteristic of a natural monopoly, and every business in which this state of affairs exists must necessarily be viewed as monopolistic in its nature. Whether the fact that large cities using many lights are paying more per light than small cities using few, is the result of ignorance, imposition, or corruption, the fact still remains, and the only remedy is enlightenment.

Before proceeding further it might be well to note one more peculiarity evinced by this investigation. The efficacy of competition as a regulating influence is something almost implicitly confided in by the American people. They do not recognize the monopolistic character of certain industries. Now, in many instances it was stated in the answers received from the various cities that the city was illuminated by contract with two and often three different electric lighting companies. But in no single case was any variation in the charge noted. Each company received the same price per light as the others. The only explanation which can be made is that by some combination the same price was fixed for each company, and that the latter divided the territory according to mutual agreement. The impossibility of competition in this line of business could not have been more clearly illustrated.

We may now ask what is the condition of affairs in those cities which own their own electric lighting plants? In the report of the Scranton committee the statistics are given as follows:

Name of Place.	No. Lights.	Cost per Annum.	Hours Lighted.
Martinsville, Ind.	30	\$40.00	Midnight.
Grand Ledge.	32	62.00	12 o'clock.
Huntington.	50	48.64	All night.
Decatur, Ills.	52	60.00	All night.
Dunkirk, N. Y.	55	36.50	All night.
Paris, Ills.	60	36.00	Except moonlight.
Easton, Pa.	64	100.00	All dark nights.
Aurora, Ills.	75	56.00	Except moonlight.
Painesville, O.	80	35.00	Except moonlight.
Ypsilanti, Mich.	80	23.61	12 P.M. not moonlight.
Madison, Ind.	85	48.00	All night.
Lewiston, Me.	96	42.00	All night.
Hannibal, Mo.	96	52.00	All night.
Little Rock.	110	47.50	When dark.
Bay City, Mich.	134	60.00	All night.
Topeka, Kas.	184	54.00	Eight hours.
Topeka, Kas.	184	72.00	All night.
Chicago, Ills.	292	65.60	All night.

The difference between this table and the one above it is surprisingly great. One cannot but wonder, upon comparing the two, why the great electric lighting companies are no richer. The averages under the two systems are instructive. The average price paid to private parties by the various cities is \$105.13 per light each year. The same service when performed directly under municipal management averages to the citizens a cost of \$52.12 $\frac{1}{2}$. Under the former method, Boston pays annually the enormous sum of \$180 per light, while the greatest cost under public control is \$100, paid by Easton, Pa. The lowest amount which corporate greed will take to loose its hold upon the public purse is paid in Cortland, N. Y., to the sum of \$50 per light each year. But Ypsilanti, Mich., by supplying herself with nightly illumination, has been able to keep the expense for the same work down to \$23.61.

The first and only conclusion to be drawn from a study of these figures is that cities can supply their own electric lighting much more cheaply and advantageously than they can obtain it from private parties.

Individual corporations cannot dispose of their product at the same price and retain a reasonable profit. The very fact that an increased number of lights are obtained at a less than proportionate increase of outlay is a strong argument in favor of municipal management. A greater number of lights are made necessary by the natural growth of a city. There is no reason why the sum thus saved, hitherto put into the coffers of private corporations, should not, by being turned into the public treasury, inure to the benefit of the people. Besides, it costs but little more to burn the lamps for ten hours than for six. If the lamps burn all night no more linemen nor other employes are required. Many cities, recognizing the advantages in owning certain enterprises, are manufacturing their own gas; many more are supplying themselves with water. In such places great saving could be effected by running an electric lighting plant in conjunction with the water works. This has been done in Dunkirk, N. Y., and has proven profitable to the city. If desirable, commercial lights might be sold; the revenue thus accruing would lessen the amount necessary to be raised by taxes. In this way the taxpayer would reap some direct benefit from the undertaking.

But it may be argued that various other considerations should be taken into account. Many municipalities stand in greater need of other improvements which demand their entire resources. To these it seems better to postpone the acquisition of an electrical plant and to leave the matter for the present in private hands. The changing condition of the electrical industry, the constant application of new inventions, the probable discovery of new processes, all advise that haste be made slowly. But that does not disprove the advisability of taking measures to obtain, without friction, municipal control of this industry in the near future. Where individuals have already invested their capital in such undertakings it is always more difficult to bring about the change; for they will take pains to prevent it as long as possible. As long as they can control the primaries and nominating conventions, the corporations are always "out of politics." They are for either party, but above all for themselves. The corruption which might possibly result from the extension of municipal functions to electric lighting and other monopolies of service, is not to be compared with the pernicious influence upon politics of private companies when seeking fat city contracts.

There are frequent complaints under the system of private management. In Scranton the local company persisted in furnishing a light of less power than that called for in their agreement. Investigation showed that instead of giving a 2,000-candle power arc light the lights had never been over 800-candle power and very seldom that, even under the most favorable circumstances. Very often they had run down to 400 or 500-candle power. The poles were placed in arbitrary positions, and the company failed to supply the lamps at intersections. This last neglect made necessary an increased number of lights, which increase, of course, is added to the profit of the company. The dirty condition of the globes furnished another cause for complaint. As far as the wires are concerned the public is well aware of the threatening danger. Everyone acknowledges that the wires ought to be placed underground; but the recent experience in New York city has shown the strength as well as the humor of the great corporations. Such trouble would be very unlikely to arise if these industries were under public control.

The advantages of public ownership of natural monopolies are beginning to be appreciated. The owners of the electric companies have perceived the trend of public opinion. One of them, in a recent work upon the subject, has enunciated the astounding principle that electric lighting, above all other industries, "is the field for private monopoly." But this proposition is far from being generally accepted. Theory as well as practice points to an opposite direction. At the banquet of the Boston Merchants' Association last winter the Hon. Seth Low, former Mayor of Brooklyn, and recently installed President of Columbia College, said, during his speech in favor of municipal ownership of these monopolies of service, "that the result of his experience in the Mayor's office for four years had been to change the whole current of his thoughts, which formerly ran away from that conclusion." In view of the general satisfaction expressed by the citizens of those cities operating their own electric lighting plants, one can scarcely fail to agree with the opinion expressed in the report of the Scranton committee to the effect that "the day is rapidly approaching when cities will no longer submit to so barefaced a fleecing process, but will own their respective plants, and thus reduce the cost of lighting to a minimum."

THE City Council of Florence, Ala., has granted a charter for the formation and operation of a gas works there. The grantees will begin construction work prior to mid-April, and they are, under the franchise, required to be in position to supply gas on or before October 20th.

[OFFICIAL REPORT.—REVISED BY THE SECRETARY.]

SIXTH ANNUAL MEETING, OHIO GAS LIGHT ASSOCIATION.

HELD AT THE BOODY HOUSE, TOLEDO, OHIO, MARCH 19 AND 20, 1890.

FIRST DAY—MARCH 19—MORNING SESSION.

The meeting was called to order by the President, Mr. Edward Lindsley, who announced that the first item of business would be the appointment of a committee on applications for new membership, and thereupon named the following as that committee: Fred. Persons, Geo. S. Harris and W. A. Ross.

On motion of Mr. Wilkiemeyer, the reading of the minutes of the last meeting was dispensed with.

REPORT OF EXECUTIVE COMMITTEE.

The Secretary—The report of the Executive Committee consists of the following recommendations to the Association. First, that the Association release from membership the nine members who have asked, in writing, to be dropped from the rolls. Those members are: Chas. M. Converse, late of Delaware, O., but now at San Francisco, Cal.; J. M. Critchlow, late of Pittsburgh, Pa., now at Titusville, Pa.; P. W. Huntington, Columbus, Ohio; W. H. Mandeville, Lima, Ohio; W. H. Gibson, Lima, Ohio; W. L. Rolston, Marietta, Ohio; A. J. Seamon, Wheeling, W. Va.; S. M. Dalzell, Cleveland, Ohio; Wm. F. Zimmermann, Pittsburgh, Pa. [Adopted.]

The Secretary read the following invitation from the Central Chandelier Company, of Toledo: "We extend through you a cordial invitation to all members of the Association to visit our new show rooms and factory while in Toledo," and further said: The Executive Committee recommend that the invitation be accepted with thanks; and they further recommend that, instead of attempting to visit the show rooms and factory in a body, our members go in groups and as may best suit their convenience.

The President—This show room is well worthy the attention of the membership, and is very convenient of access from the hotel, being, I think, less than a block away. I do not suppose that it would be convenient for the members to visit it in a body, but if they feel disposed to accept this invitation in the manner suggested by the committee, I think they will find it exceedingly profitable. [Adopted.]

The Secretary—The third recommendation is that the Association bear the legitimate expenses incurred by local companies in connection with annual exhibits of gas apparatus.

The President—This is a matter of some little importance, gentlemen. The Secretary has this year acted on his own responsibility. I think he has done wisely, and I believe you will all endorse him. But as an expenditure of money is involved, I think there should be some formal action by the Association. What action will you take, gentlemen, with reference to this matter?

Mr. Wilkiemeyer—Mr. President, I move the recommendation be adopted. As the exhibits are for the benefit of the gas companies entirely, we certainly ought to pay the small expense that has been incurred, and I move that recommendation be adopted.

The President—Gentlemen, it is moved and seconded that the legitimate expenses attending the exhibit, which is a very important feature of our meetings, be borne by this Association. This covers the ground, I believe. Are there any remarks?

A Member—Mr. President, had it not better be understood what you term "legitimate expenses?" What is covered by that? It may prevent confusion to have it definitely stated.

The President—I will call upon the Secretary to explain?

The Secretary—In the Committee meeting the legitimate expenses were designated to be those incurred in bringing goods for the exhibit from the depot, unpacking them, setting them up in the exhibit room, gas pipe connections, and, after the exhibit, disconnecting and repacking them, and hauling them to the depot; also, the rent of the room where the exhibit is held, and the cleaning up of the room. [Adopted.]

The Secretary—Fourth, that the Secretary may be instructed to ascertain, during the ensuing year, the wishes of each member regarding the adoption of a badge for the members of this Association. [Adopted.]

The Secretary—Fifth, that the Secretary be authorized to have printed, in advance of each annual meeting, the papers that are to be read at the meeting, and as soon as possible after the meeting, the papers and the discussions thereon shall be printed in pamphlet form and distributed to the members. [Adopted.]

The Secretary—Sixth, the Executive Committee recommends the election to honorary membership of Mr. Emerson McMillin.

The President—Gentlemen, you have heard the name of Emerson McMillin announced for honorary membership in this Association. As you all know, he is already an active member. That, perhaps, is a little superfluous to say. He is the father of this Association. I do not need to say more for him than that. You all know that we are largely indebted to him for our existence as an Association and for our maintenance thus far. The fraternity of gas men is also indebted to him, and likely to be in the future, for a measure of usefulness that we can scarcely find perhaps in any other man. We will lose an active member here, and perhaps we might lose something were our organization different from what it is. But I think we will not lose anything, and I think it is eminently fitting that we make Mr. McMillin an honorary member of this Association.

Mr. Gwynn—I move you, Mr. President, that the recommendation of the Committee be adopted. (The motion was duly seconded and carried.)

The Secretary—Seventh, that the Secretary's salary be increased to \$300 a year. [Adopted.]

REPORT OF COMMITTEE ON LEGISLATION.

The President—Next thing in the order of business is the report of the Committee on Legislation. Is that Committee ready to report?

Mr. Wilkiemeyer, on behalf of the Committee, reported: "The Committee on Legislation has had several questions propounded to it, but as it does not find its duties and powers sufficiently defined for action, it has hesitated in the matter, and taken no action. Provisions should be made at this meeting, by giving this Committee definite instructions, as to how and when it shall take action in matters appertaining to the welfare of the gas business. Expenses possibly would be entailed, and the Committee should be empowered to draw upon the Association's funds for all such legitimate expenses. Respectfully submitted,

March 19, 1890. A. J. STOLL,
EDWARD LINDSLEY, } Legislative Committee."
H. WILKIEMEYER,

On motion the report was received and placed on file.

ANNUAL REPORT OF SECRETARY, MARCH 19, 1890.

In the hands of Secretary at beginning of year.....	\$246.26
Received as dues and initiation fees.....	400.00
Total credits.....	\$646.26
Remitted to Treasurer, March 26, 1889.....	\$390.26
" " " 13, 1890.....	120.00
Total debits.....	\$510.26
Balance in hands of Secretary.....	\$136.00
Dues for 1888, still unpaid.....	\$6.00
" 1889, " 	39.00
" 1890, " 	225.00
Total dues unpaid.....	\$270.00

New members admitted at last meeting.....	22
Released from membership.....	12
Elected from active to honorary membership.....	1
Total honorary members elected.....	2
Present number of active members.....	128
" " " honorary members.....	9
Number of members deceased during past year.....	0

Respectfully submitted,

IRVIN BUTTERWORTH, Sec'y.

On motion of Mr. Persons the report was accepted and placed on file.

Mr. Cantine—Mr. President—How many members of this Association are required to form a quorum?

The Secretary—The Secretary can tell you as soon as the Constitution will tell him. The question has never come up before, and I am not familiar with that point.

The President—Three members shall be a quorum.

Mr. Cantine—That is about the number we have present, if I judge by the responses I have heard. I wish every member would vote aye or no. It would be more pleasant. About 25 per cent. of the moving I have been doing myself.

The President—I hope Mr. Cantine will receive more help in that direction. The Secretary has made a pretty good suggestion that comes in right here. There are quite a number of vacant chairs up here, and I think if the gentlemen in the back part of the room were more nearly in front we perhaps would feel a little more communicative. I wish the gentlemen in the back part of the room would occupy the chairs in front. (The members came forward and occupied front seats.)

LETTERS OF REGRET.

The President—Our Secretary has received some communications, the nature of which he will explain if you will now listen.

The Secretary—We have a number of letters from prominent gas men over the country expressing their regret at their inability to be present at this meeting. I will merely read their names, as the letters are too numerous and too long to be read :

W. E. Barrows, Philadelphia, Pa.; A. S. Bushnell, Springfield, O.; Samuel T. Bodine, Philadelphia, Pa.; T. M. Cox, Rochester, N. Y.; W. H. Denniston, Pittsburgh, Pa.; Frederic Egner, St. Louis, Mo.; A. C. Humphreys, Philadelphia, Pa.; G. A. Hyde, Jr., East Saginaw, Mich.; N. G. Keenan, Cincinnati, O.; Bement Lyman, Indianapolis, Ind.; A. S. Miller, Omaha, Neb.; Northrop Moore, Wyandotte, Kas.; Charles H. Nettleton, Birmingham, Conn.; C. F. Prichard, Lynn, Mass.; George G. Ramsdell, Vincennes, Ind.; Samuel G. Stiness, Pawtucket, R. I.; Louis Wagner, Philadelphia, Pa.; Adam Weber, New York City; William Henry White, New York City; William Enfield, Dallas, Tex.; E. C. Brown, New York City; Eugene Vanderpool, Newark, N. J.; A. B. Slater, Providence, R. I.; W. H. Pearson, Toronto, Ont.; C. J. R. Humphreys, Lawrence, Mass.; R. J. Monks, Boston, Mass.

The President—I suppose no action is required on this matter. We are glad to hear from these gentlemen, and would have been very glad to have welcomed them to our meeting. The next thing in order is the election of new members. Is the Membership Committee ready to report?

ELECTION OF NEW MEMBERS.

Mr. Persons—Mr. President, your Committee has 33 applications, upon which it reports favorably in each case. The names are :

A. P. Lathrop, Columbus, Ohio; E. P. Callender, New York City; Andrew Harris, Phila., Pa.; F. A. Wilke, Richmond, Ind.; D. E. Dangler, Cleveland, Ohio; Fred. Bredel, New York City; A. E. Rood, Toledo, Ohio; G. S. Fowler, Lima, Ohio; J. G. Stephens, Pittsburgh, Pa.; W. L. Ley, St. Louis, Mo.; A. H. Johnson, Oberlin, Ohio; O. F. Webster, Owosso, Mich.; W. P. Bonny, Erie, Pa.; Geo. Osius, Detroit, Mich.; J. M. Armstrong, Delaware, Ohio; L. Stockstrone, St. Louis, Mo.; H. E. Floyd, New York City; A. H. Jones, Columbus, Ohio; A. F. Nash, Windsor, Ont.; Geo. Whysall, Springfield, Ohio. E. N. Lewis, Defiance, Ohio; C. F. Adams, Chicago, Ill.; H. D. Harper, Chicago, Ills.; W. W. Douglass, Ann Arbor, Mich.; D. P. Russell, St. Louis, Mo.; L. Moore, Joliet, Ills.; Geo. M. Clark, Chicago, Ills.; G. A. Allen, Zanesville, Ohio; E. C. Brown, New York City; J. A. Faux, Pittsburgh, Pa.; Chas. A. Marden, Coshocton, Ohio; John M. Tryon, Van Wert, Ohio; G. A. Hyde, Sr., Cleveland, Ohio.

On motion, the Secretary cast the ballot of the Association in favor of the election of the foregoing applicants.

The Treasurer then read his report as follows :

REPORT OF TREASURER.

Herman Wilkiemeyer, Treasurer, in account with the Ohio Gas Light Association, March 19th, 1890.

	<i>Cr.</i>	
March, 1889, balance	\$717 90	
Interest collected on this account	2 33	
March 26th, received dues remitted by the Secretary.....	390 26	
March 15th, 1890, received dues remitted by the Secretary	120 00	
Interest earned on \$874.94 to date.....	34 05	
	—————	\$1,264 54
	<i>Dr.</i>	
Irvin Butterworth, salary, etc., as per voucher attached	\$169 47	
Ohio State Journal, printing, etc.....	44 00	
H. Wilkiemeyer.....	22 08	
	—————	\$235 55
Balance in the hands of the Treasurer.....		\$1,028 99

Respectfully submitted,

HERMAN WILKIEMEYER, Treas.

PORTSMOUTH, Ohio, March 19th, 1890.

On motion the report was referred to the Finance Committee.

ROLL CALL.

The President—The next item of business is the roll call.

Mr. Padan—I would like to ask what action the Association wishes to take in regard to the Committee on Legislation. Their report has been received and I would like to know whether the Committee is in existence, and whether anything further is expected of the Committee on Legislation?

The President—I suppose the Committee is virtually discharged.

The Secretary—Mr. President, I move you that the subject of the continuation of the Legislative Committee be deferred until after the discussion of Mr. Wilkiemeyer's paper. (The motion was carried.)

The President—You will now listen to the roll call. Gentlemen, if in the calling of the roll a name should be called of a member that is known to be in attendance by any member present, but who is just now absent from the room, I wish such member would respond for that name. We would like to make this roll represent those who are really here, and to that end if each member would bear in mind and respond, it will help to make it so. At this point the roll was called by the Secretary, and the following members were shown to be in attendance :

- | | |
|--------------------|----------------------|
| Jos. R. Thomas. | Murray McMillin. |
| Geo. W. Graeff. | Geo. Matt. |
| John W. Alexander. | John Mills. |
| Miller Booth. | Henry Padan. |
| Irvin Butterworth. | Jerome Penn. |
| W. W. Cantine. | Fred. R. Persons. |
| Geo. H. Christian. | J. H. Phillips. |
| G. N. Clapp. | W. W. Prichard. |
| D. M. Clark. | Eugene Printz. |
| A. D. Cressler. | Henry Ranshaw. |
| John Dell. | A. C. Reichelderfer. |
| Chas. H. Dickey. | D. T. Roots. |
| R. A. Dittmar. | W. A. Ross. |
| Chas. H. Evans. | E. M. Russell. |
| C. R. Faben, Jr. | E. E. Schaff. |
| O. N. Guldin. | James H. Smith. |
| J. W. Gwynn. | F. N. Sisson. |
| Jos. Gwynne. | John W. Skinner. |
| A. N. Hammond. | D. C. Spinning. |
| J. A. Harris. | Wm. Stacey. |
| H. L. Hurlburt. | A. J. Stoll. |
| Richard Lee. | S. S. Stratton. |
| Edward Lindsley. | L. A. Strong. |
| Geo. Light. | Geo. H. Tayler. |
| Hugh McCall. | R. Turner. |
| Geo. W. McCook. | E. C. Warren. |
| Wm. McDonald. | Chas. H. Welch. |
| John McIlhenny. | H. Wilkiemeyer. |

REPORT OF FINANCE COMMITTEE.

The report of the Finance Committee was then read as follows :

“Mr. President and Gentlemen of the Ohio Gas Light Association :—Your Committee have examined the report of the Treasurer and find it correct. It shows a balance on hand of \$1,028.99, for which the Treasurer holds a certified check.

GEO. H. TAYLER,
W. W. PRICHARD, } Finance Committee.”
M. McMILLIN,

The report was accepted and placed on file.

Mr. Ross—Mr. President, I would like to get the sense of the meeting as to whether it would be well to instruct our finance committee to investigate the matter of a possible reduction in the annual dues. It seems to me we are accumulating money unnecessarily. If our expenses for the ensuing year are such that we can make a reduction in the annual dues we should do so. My idea would be not to reduce the initiation fee, but the annual dues, so that we will not accumulate any more money in the treasury than we need. I make it as a suggestion.

The Secretary—Mr. President, if you will permit me, the expenses of the Association will be much larger in the future than in the past, and my impression is that we will not be able to add to our account in the treasury in the future to any great extent, but the tendency will be to reduce it. It is nice to have that surplus on hand, and I don't think the Association can afford to reduce the dues.

Mr. Ross—My object in making the suggestion was simply to draw out a little talk, to see what the sentiment of the members is; and if, as the Secretary says, we cannot make a reduction, the Finance Committee could make an estimate of what our expenses and probable income would be. They might make a report, and then the Association could take action afterward. I would then put it in the form of a motion, “That the Finance Committee be instructed to estimate what the probable expenses of the Association for the coming year will be, and what the probable income will be, and to report whether they think it possible to make a reduction without interfering with our business and have plenty of money to get through with.”

A Member—The funds seem to accumulate under the management of the Secretary, and pretty soon we can start a bank.

The President—Gentlemen, excuse me a moment. The motion has not been stated from the Chair, and possibly some in the rear part of the room may not fully understand it. I would make a suggestion, before stating this motion, that I believe it would add to the facility of doing our business if we would make our motions in writing, in the main—with motions of this character at least. With that suggestion, I will endeavor to repeat the motion of Mr. Ross, and he can correct me if I mistake it. The motion is that inasmuch as we seem to be rather accumulating funds, the Finance Committee take the matter under advisement and make a report as to whether the annual dues, but not the initiation fee, can safely be reduced. Is that the spirit of the motion?

Mr. Ross—Yes, sir.

The President—That is the spirit of the motion. Are there any further remarks?

Mr. Padan—I would like to ask if the motion is in order?

The President—It is not strictly in the order of our business, perhaps.

Mr. Padan—I do not mean the order of the business. The dues are prescribed in a by-law in the Constitution; therefore, I think it is not in order.

Mr. Booth—I think that motion is not out of order. It is only to refer the matter to the Finance Committee for them to make a suggestion in case they decide that the dues can be changed. If so, then a change in the by-laws would be in order. It is not to take definite action at all, as I understand it. After the recommendation would come the change in the by-laws. The motion, I claim, is in order.

The President—I think that is correct. It will be so ruled, that the motion is in order. Are there any further remarks?

Mr. Tayler—I would like to inquire of the Secretary how much that balance on hand will be reduced after the expenses of this meeting are paid?

The President—Perhaps the Secretary can give that information.

The Secretary—At a rough estimate I would say it would be reduced \$400. We will have expenses incident to the exhibition at this meeting, as well as those incident to the exhibition at Mansfield last year, which amounted to nearly \$100 there, and probably amount to more here.

The President—Are there any further remarks? [The motion was put and lost.]

APPOINTMENT OF COMMITTEES.

The President then announced the following committees:

On the Place of Next Meeting.—Messrs. Eugene Printz, G. A. Hyde and George Matt.

On Nominations.—Messrs. D. M. Clark, W. W. Cantine and A. N. Hammond.

(To be continued.)

Alavoine's Gas Washer.

U. S. Letters Patent (No. 422,173) were granted on February 25th, to M. F. A. M. Alavoine, of Beauvais, France, for an improvement in gas washers. The American patents are in supplement of those previously granted the inventor by the Governments of France, England, Belgium, Austria, Italy and Spain. Using the language of the Alavoine specification, the invention and its application are thus disclosed:

The invention relates to that class of purifiers which receive the gas directly from the retort, known as "barillet" purifiers; and the object is to provide the gas inlet of the purifier with a submerged screen or foraminous distributor, whereby the gas is compelled to pass through the wash water for a considerable distance before it escapes at the surface thereof. The volume of gas is divided by foraminous partitions or plates as it flows along the tortuous course from the point where it enters to the point where it leaves the water; but the construction is such that there is no appreciable loss of pressure.

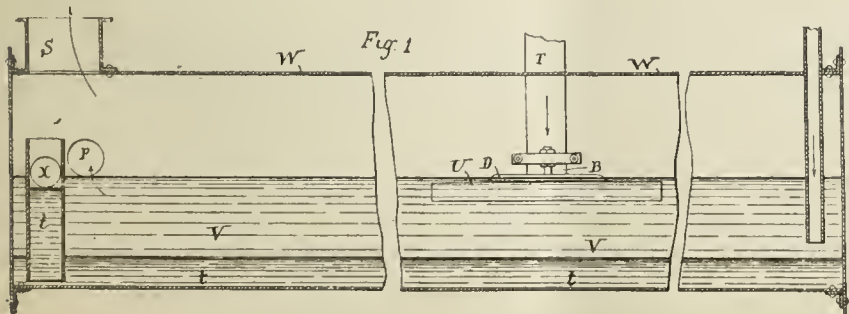

In the accompanying drawings, illustrative of the improvements, Fig. 1 is a longitudinal vertical section of the purifier as a whole, the submerged distributing screen being represented in elevation; Fig. 2 is a

longitudinal vertical mid-section; and Fig. 3 is an under side plan view of the distributing screen detached, and on a larger scale than Fig. 1.

In Fig. 1 *W* represents the drum of the purifier; *V* the water therein; *P* the overflow outlet for the water; *T* the gas inlet; *U* the submerged distributing screen, as a whole; *S* the gas outlet; and *X* the outlet for the tar, *t*, which collects in the bottom of the drum.

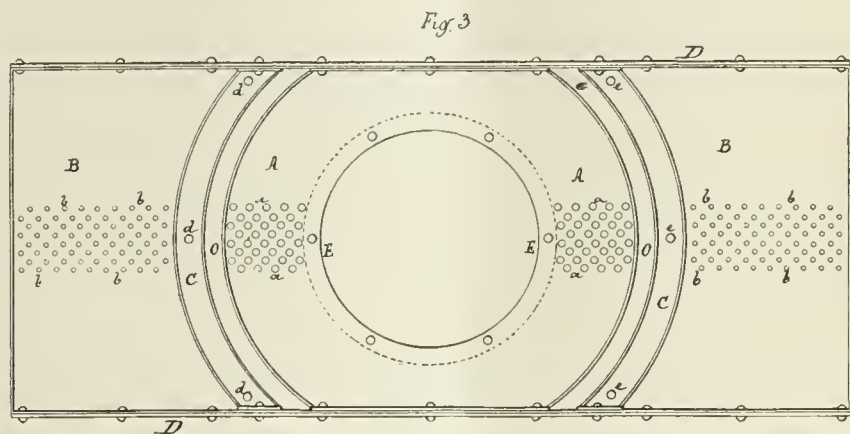
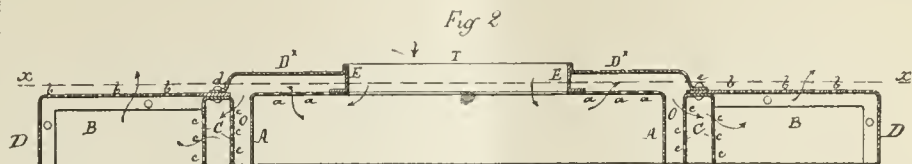

The submerged purifying screen (illustrated in Figs 2 and 3) consists of a bell *D*, provided with an elevated central crown-plate *Dx*. In this crown-plate is fixed a collar *E* to receive the gas inlet pipe *T*. This collar extends below the plate *Dx* and to its inner end is secured a bell, *A*, of particular form, as seen in plan in Fig. 2. Exterior to the bell *A* on both sides thereof, are annular pendent partitions *C*, arranged as shown. *B* are end chambers within the bell *D*.

The dotted lines *xx* in Fig. 2 indicate the water level and the extent to which the screen will be submerged. The bell *D* will, of course, be full of water. The gas under pressure and directly from the retorts, descends through the pipe *T* and enters the inner bell *A* through the water. It rises and flows out from the bell *A* through the larger perforations *a* in the crown-plate or roof of said bell and enters the space under the plate *Dx*. Thence it flows downward into the annular space *O*, exterior to the imperforate wall of drum *A*, thence laterally through the perforations *c* in the pendent partitions *C* into the end chambers *B*. It rises in these chambers and escapes from the bell *D* through the finer perforations *b* in the roof of said end chambers. The gas now rises to the surface of the water and flows off at the gas outlet *S*. In its flow through the screen *U* the gas is submerged, and being divided or broken up by the perforations through which it must pass, every part of it is brought into contact with the water and thoroughly washed. The passage of the gas successively through perforations of less and less diameter prevents any material loss of pressure. In its passage through the purifier the gas parts with nearly all of its tar, the major part of its sulphydric acid, a large percentage of its carbonic acid, and a considerable proportion of its ammonia. The tar falls to the bottom, and may be removed at the outlet *X*, and the ammoniacal water overflows at the outlet *P*, which serves to preserve a uniform level of the water in the cylinder.

This apparatus is very uniform in its action, and the body of gas is so subdivided as to present every molecule or portion of the same to the water.

To avoid unnecessary repetition, in Fig. 2 is only represented a portion of the perforations *a* and *b*.

Having thus described his invention, M. Alavoine claims—

In a gas purifier, the combination, with the drum or water receptacle of the purifier and the gas inlet pipe *T*, of a foraminous gas distributing screen *U*, connected with said inlet pipe, said distributing screen consisting of the bell *D*, having endchambers *B*, provided with perforations *b*, an inner bell *A*, having perforations, *a*, in its roof, and pendent foraminous partitions between the wall of said inner bell and said chambers *B*, the perforations *a* being larger than the perforations *b* as set forth.

THE proprietors of the Cambridge (Mass.) Gas Company, in pursuance of the liberal policy that has always characterized their ownership and operation of that business, have announced that on and after April 1st the selling rate is to rule at \$1.60 per 1,000 cubic feet. This is a reduction of 15 cents per 1,000. That this method of treatment fosters the consumption of gas in beautiful Cambridge is best shown in the fact that the output increase averages 10 per cent. per annum.

SPECIAL ENGLISH CORRESPONDENCE.

COMMUNICATED BY NORTON H. HUMPHRYS.

SALISBURY, March 10, 1890.

Gas Managers' Spring Meetings.—The Institution of Gas Engineers.—Van Steenberg's Carbureted Water Gas.

Gas managers have already begun, as usual at this season of the year, to meet. Three of the spring assemblies of the District Associations are already matters of history, and three more will also have entered that category before these lines reach their destination. A prominent feature at these meetings is the inaugural address delivered by the newly-elected President for the year, which has gradually grown from a few commonplace remarks, possessing little more than local interest, to an elaborate literary effort, occupying one-half to three-quarters of an hour in delivery, and usually including a review of all matters of present special interest to the auditory, in addition to the results of special individual experiences. Anyone who carefully reads the Presidential addresses will acquire a fair idea of the various matters that are at present occupying the minds of gas engineers in this country, and of the progress of events in gas circles during the last twelve months.

The principal topics receive attention, of course, from each one, and thus an interesting insight is afforded into the effects of personal peculiarity, experience, and environment as influencing the particular view taken of the same subject. The labor question claims the first place, especially in regard to the operations of the "Gas Stokers' Union." On this subject there is perhaps a tendency to be rather too rosy as regards the future. Such may only be expected on account of the decisive nature of Mr. Livesey's action in shaking himself free from the chains of the Union. Without making any invidious comparisons, it may be said that few gas undertakings possess the resources that are at the disposal of the South Metropolitan, or the spirit of unanimity, harmoniousness, and fidelity to headquarters that animates the whole of the superintending and office staff. The Manchester Corporation, too, are to be congratulated on their success in resisting the unreasonable demands of the men. But while the Union has received a severe and crushing defeat in both these cases, it is useless to ignore the fact that in many other towns the victory has been on the side of the men, and that, chiefly by means of highly colored and grossly exaggerated representations of the nature of the work done, they have secured the support of influential persons, professors of religion, and others whose opinions are influenced by sentiment rather than by fact. So it can scarcely be concluded that further attempts will not be made, and it behoves the managers of gas works to consider the advisability of meeting this state of affairs, perhaps, by some sort of employers' union. The Gas Stokers' Union already recognize the causes which led to their defeat, and if they should try a strike again will take care to select a Company that does not possess a deservedly popular and honored Chairman, widely known for his sympathy and kindly dealing with the working classes, a thoroughly loyal superintending and office staff, and last, but not least, a reserve fund of forty thousand pounds. Mr. May, President of the Southern Association, gives some noticeable results, showing the economy resulting from the use of machinery in his retort houses. After several years experience in this direction he finds that the cost of wages, including all charges from the coal stove to the coke yard, also wear and tear of machinery, is just under 2d. per 1,000 cubic feet of gas made. Under the new labor arrangements most gas companies are paying more than double this amount. Water gas comes in for a fair share of attention, and the fact that it can be manufactured with the aid of a much smaller staff of workmen than that requisite for coal gas, apart from other considerations, is sufficient to secure for it a respectful hearing. Mr. May also gives some valuable records of his experience in admitting measured quantities of air at the inlet of the purifiers, by which means he is able to reduce the expense of removing sulphureted hydrogen, carbonic acid, and keeping the sulphur compounds under 20 grains per 100 cubic feet, to less than 0.25d. per 1,000 cubic feet of gas. This advantage is secured without any loss of illuminating power, as proved by careful experience. Mr. Peaty, President of the Midland Association, touches upon the position of oil and electricity, each of which he considers to have a definite field of usefulness. He searchingly criticises the action of municipal authorities, who, being owners of gas works, apply the profits obtained by the sale of gas to various public purposes, even including experiments with the electric light; and insists on the importance of selling gas at the lowest price that is practicable, so as place it in a good position as regards competition. The increased price of coal naturally directs attention to improved

carbonizing processes, such as the Coze inclined retort and the Dinsmore process. In respect to both inventions, gas engineers are in a waiting position, looking for the results of practical experiments on a working scale. These, in respect to the latter at any rate, will shortly be available. The same may be said of the plan of supplying cottages and small tenements with the necessary pipes and fittings free of charge, and slightly increasing the cost of the gas as a means of paying interest on the capital so invested. This plan is being tried at London, Ramsgate, Stafford, and other places, usually in connection with prepayment meters. Mr. W. W. Hutchinson, President of the Manchester District Association, directs attention to the magnitude of the gas industry as shown by the latest Government returns available, and also draws a strong but by no means exaggerated picture of the numerous difficulties with which the gas engineer of the present day has to contend. This gentleman also devotes considerable attention to the effect of the electric light upon the consumption of gas, showing conclusively that its production in London and various other towns has not interfered in any way with the steady increase in the demand for gas that has lately obtained. All these gentlemen allude in the course of their addresses to some remarkable statistics recently given by Mr. John West, of Manchester, President of the Manchester Association of Engineers, who, taking actual practical data, shows conclusively that gas at the prices now obtaining in our large towns is over four times as cheap, light for light, as the electric light. If improved regenerator burners be used, it is eight times as cheap. Taking as a standard the production of 16,000 candle hours, he shows that at 8d. per unit, the price actually charged by companies now supplying electric light, the cost of this quantity of light would be \$10.50. With regenerator gas burners it would be \$1.25 to \$1.50, and with ordinary burners \$2.50 to \$3. Mr. West also brings out the remarkable fact that the proprietors of several private installations, where the electricity is generated on the premises by means of a gas engine, are able to supply themselves very much cheaper than the rate above mentioned as charged by the electric companies. In some cases the cost, inclusive of interest on capital, wear and tear, etc., is less than one-half. Of course in many private installations a spare corner can be found for the gas engine and dynamos, thus avoiding the cost of special buildings; but the great advantage afforded by private as compared with central supply electric stations, is the avoiding the cost of conductors, and the leakage in course of distribution.

Our already lengthy list of technical societies has been increased by the formation of the "Institution of Gas Engineers," which has been promoted under the auspices of some of the gentlemen who retired from the Gas Institute a year ago. So far as can be gleaned from the editorial columns of the *Journal of Gas Lighting*, the object of the new Institution is to form a more select body than that afforded by the Gas Institute. Membership into the latter society is open to anyone that can reasonably be described as a gas manager, and secure a proposer and seconder; but the new Institute will only admit persons who "by training and profession are *bona fide* gas engineers." In the Gas Institute, proposal forms for membership are signed by a proposer and seconder, and afterwards examined by the Council, but this plan is to be improved upon in the new Institution. The new society is to be an "Association of technicians for the cultivation of the art and practice of gas engineering," and all persons who are "unskilled and consequently uninterested" are to be kept out. Speaking broadly, the effect of this arrangement will be to exclude the managers of small gas works, as well as those (and they are not a few) who have risen from the ranks. Much depends, of course, upon the definition of the word "training." What with district associations, the Gas Institute, and the Institution of Gas Engineers, the members of the craft will have no difficulty in filling up their spare time. It is also mentioned that the new Institution is in no sense a rival to its older confrere, but this is only true in a limited sense. The objects of both must necessarily run on very similar lines, and the chief hunting ground for recruits for the Institution will be amongst the members of the Institute. Both may exist, side by side, but only in a dwarfed and enfeebled condition as compared with what a single Institution might be. It now remains for the new Institution to show what special benefits it can secure, either for its members or for our industry at large, that could not have been afforded by the Gas Institute.

An experimental trial of the Van Steenberg water gas process is being conducted in London, under the supervision of Prof. Vivian B. Lewes, who is a well known authority on such subjects. According to some results lately published, it appears that he has succeeded in manufacturing 20½-candle gas with a consumption of 24½ lbs. of anthracite, and 2.80 gallons of naphtha (70° Beaume) per 1,000 cubic feet of gas.

A peculiarity of this process is that the naphtha is to a large extent reduced to hydrogen and marsh gas. There is only 7.6 per cent. of illuminants, and 40 per cent. of hydrogen against only 25 per cent. of carbonic oxide, while the quantity of carbonic acid in the crude gas is only 2.15 per cent. There is 17 per cent. of marsh gas, and the assistance of the atmosphere is called in to increase the bulk of the product, as shown by the fact that nearly 10 per cent. of nitrogen is present. The composition of gases from 76° naphtha, in conjunction with various carbonaceous fuels, is also given. Foundry coke yields a gas of 22½-candle power, low in respect to hydrogen and carbonic oxide, but rich in marsh gas and illuminants. Gas coke yields a gas containing 6 per cent. of carbonic acid, but, apart from this objection, of good quality, containing 39 per cent. of hydrogen and 26.7 of marsh gas in the purified gas, and possessing an illuminating value of 22.9 candles. The high proportion of carbonic acid is ascribed to the fact that the fuel will not heat up so well as anthracite. With the latter fuel the result is very similar to that obtained from the 70° naphtha. There is rather less hydrogen, and more marsh gas. It is remarkable that a noticeable proportion of free oxygen is present, in one case as much as 1.3 per cent., and this seems to indicate, especially in conjunction with the large proportion of nitrogen, that the gases are "exhausted" out of the producers with a considerable degree of vacuum.

ITEMS OF INTEREST FROM VARIOUS LOCALITIES.

SOME time ago we noted that the plants of the Batavia (N. Y.) Gas Light Company and the Consumers Electric Light and Power Company had been purchased by a syndicate with a view to consolidating and reorganizing the same. The details of the plan have been carried out with the result that the Companies have been reincorporated as the Consolidated Gas and Electric Company of Batavia, with Messrs. Samuel D. Purdy, Henry Craft, Chas. H. Caldwell, Richard C. Garhart and Russell L. Kinney as the incorporators. The capital stock has been put at \$100,000, and the Company promises to be in every sense prosperous.

A CORRESPONDENT forwards the following: "Some days ago to a select coterie Gen. Hickenlooper was relating a story respecting the late Wm. Mattox, which story contained a moral illustrating the expediency of each man minding his own business. He was then, as now, living out on Dayton street, and on a lot, which he passed every day on his way to and from the office, Mr. Mattox was erecting a dwelling house. One day the General passed by as usual, and found the builder sitting on a brick pile, gazing contemplatively towards the cornice which was just being put into place by the workmen. He stopped and said: 'Mr. Mattox, I am afraid that you are going to get that cornice too heavy for the rest of the building.' 'I am sorry, mighty sorry, that you did not come along a few days sooner, General,' was the response; 'for I am trying to put this house up in full accord with the wishes of my neighbors, and if you had spoken just a little earlier I would have left the work without a cornice.'"

THE Gas Commission will on the 7th inst. open bids for the public lighting of this city. Much interest attaches to this competition, in respect to the course that the electric lighting companies have agreed on.

MR. H. D. FITCH, of Louisville, Ky., has purchased the plant and franchises of the Sherman (Texas) Gas Light Company, and will make important improvements on the works and mains systems. This purchase places Mr. Fitch in control of about ten gas works, mostly in Kentucky and the South.

FITCH evidently means to "boom" gas sales in Sherman, for about the first thing that he did in connection with his newly acquired property was to put the selling rate (for lighting and other uses) at \$1.90 per 1,000 cubic feet, net, prompt payment, of course, being an essential to sharing in the concession. Whether this was a "heroic slash" or not is best determined from the simple announcement that the old rate was \$3. In order to popularize the use of gas for cooking, the Company agrees to put in a cooking stove, of any size desired, and allow the same to remain on trial for 30 days. If at the end of that period the consumer is dissatisfied the stove will be removed, at the Company's expense; but if the consumer is satisfied he will be required to pay only the actual cost of the stove to the Company. That is the way to do it, Mr. Fitch.

AT the annual election of the Bay State Gas Company the following officers were elected: President, J. Edward Addicks; Vice-President, Henry C. Gibson; Secretary, W. H. Miller; Treasurer, F. B. Addicks.

WE understand that the sale (reported by us some time ago) of the Evansville (Ind.) Gas and Electric Light plants to an Eastern syndicate has not been consummated.

COL. JEROME CROUL and Mr. I. C. Baxter, of the Detroit (Mich.) Gas Light Company, have been having a busy time of it in arranging for the betterments that are to be made on that plant this season. Their journeyings, however, have not been fruitless, as will be seen from the following summary of the contracts that they have concluded. In the first place, Mr. James Gardner, Jr., of Pittsburgh, will put in two full-sized benches of the McIlhenny type, through retorts, that are to be erected alongside of the two large benches of the Arndt type which were installed last year, and which are carbonizing 4,700 lbs. of coal in four hours, or 2,350 lbs. to each side. All the ironwork for the new benches is to be furnished by the Bouton Foundry Company, of Chicago, the stand-pipes, etc., to be 8 inches. Each bench is to be fitted with a (separate) diaphragm hydraulic main. At the upper end of the retort house is to be erected a double set of the improved Lowe apparatus, each set to have a capacity of 400,000 cubic feet each 24 hours. The apparatus is to be adapted to the use of Lima crude oil, and to take hot coke, drawn from the retorts and "dropped" into the generator. Messrs. Morris, Tasker & Co. have completed for the Company a 600,000 cu. ft. holder, which is inclosed in a brick building, covered with an iron (trussed) roof, slated. All the light is admitted from the roof, which carries glass—½ in. thick by 6 ft. square panes. This material runs all around the roof of the building, and about 2 feet from the gutter line. The house carries two doors (no windows), and is surmounted by a large cupola, the ventilators to which are opened and closed automatically from below.

THE annual meeting of the Superintendents in the service of the United Gas Improvement Company, of Phila., Pa., was held at the Continental Hotel, in that city, on the morning of the 18th inst. The proceedings were of a most interesting nature, and the meeting was largely attended.

A CORRESPONDENT, writing from Joplin, Mo., under date of March 12, says: "The much talked of purchase of the Carthage gas works and electric light plant and the Joplin gas works by a Fort Scott (Kas.) syndicate has taken place, and articles of incorporation have been filed under which the Carthage Light and Fuel Company and the Joplin Light and Fuel Company, come into existence. Each enterprise is capitalized in \$100,000, and the owners of the properties are Messrs. H. C. Messenger, C. H. Malin, H. A. Malin, S. B. Malin and George B. Campbell. All of these gentlemen, save the first named, are residents of Fort Scott, and they have secured two valuable artificial lighting properties. They will take absolute possession at Carthage on April 1st, and at Joplin on April 15th. Mr. Messenger, who is in charge of the water works system, will also have charge of the syndicate's gas and electric light properties. The plants will be overhauled and enlarged, but perhaps the greatest expenditure will be in line of adding to the main systems."

MR. CORNELIUS E. DURKEE has been appointed Superintendent of the Saratoga Springs (N. Y.) Gas and Electric Light Company. Mr. Durkee is a capable and clever man, and the proprietors of the Company would be in far better position now did they commit their interests in that property to a competent manager at an earlier period in its history. Through gross mismanagement the Company has been brought in disrepute among the residents, hence Mr. Durkee's task is a trying one. He has pluck and capacity, and will likely succeed in hauling the chestnuts out of the fire for those whose penny-wise, pound-foolish policy thrust the fruit in the flames. It never yet paid the proprietor to be strong in the belief that an ignorant day-laborer could stand in the place of an intelligent gas maker. In other words, a day-laborer makes the most expensive sort of an "engineer."

MR. JOHN CARSCOT, who has filled, since 1869 (with credit to himself and with satisfaction to the taxpayers), the post of City Clerk, of Madison, Wis., was, on the evening of March 18th, presented with an elegant gold watch and chain, that had been purchased from a subscription list on which figured the names of those who had served as Mayors, City Attorneys and Aldermen during Mr. Carscot's term of office, as a testimonial to his worth. The interest that gas men have in Mr. Carscot, however, is to be found in the fact that he ceases to act as City Clerk of Madison in order that he may become Secretary of the Madison Gas Light Company.

A MARLBORO (Mass.) correspondent forwards the following: "The rumor that Mr. William Anderson, the efficient Manager of the Marlboro

Gas Light Company, has engaged his services to the East Boston (Mass.) Gas Light Company, and will enter upon his labors there on July 1st, is not denied by that gentleman. We are sure that all the patrons of the Marlboro Gas Light Company who have any recollection of the Company's manufacturing facilities and works previous to Mr. Anderson's taking control thereof on February 1st, 1887, will be sorry of his conclusion to relinquish his position. However, as he gets a large increase of salary, with less of detailed routine work, the move is a wise one on his part. Good men are scarce, but the East Boston Gas Light Company knew where such an one was located, and they are, in my opinion, lucky in securing him. A large number of Marlboro's citizens will wish Mr. A. the success he deserves and will undoubtedly meet with in his new location." We heartily share in the wishes of Marlboro's citizens, and congratulate Mr. Anderson on his promotion. That it is deserved goes without saying.

MR. DANIEL H. HENSLEY, Secretary and Treasurer of the Hamilton (Ohio) Gas Light and Coke Company, has been appointed postmaster of that city. The appointment gives great satisfaction.

THE dividend of 2½ per cent. declared on the preferred stock of the Laclede Gas Company is payable on and after to-morrow.

THE Gas Inspector of San Francisco (Mr. John G. Brown) reports that the average quality of the gas supplied in that city during the week ended March 17th was: San Francisco Gas Company, 17.38 candles; Pacific Gas Improvement Company, 17.50.

ADVICES from Salt Lake City, Utah, are to the effect that the negotiations which have been underway for some time looking to a change in the management of the Salt Lake Gas Company, have been completed. Under the agreement Messrs. T. W. Ellerbeck, Henry Dinwoodey and James Jack resigned from the Board of Directors, and Messrs. Thomas Marshall, Frank H. Dyer and P. L. Williams were chosen in their stead. The reconstructed Board then elected Thomas Marshall as Vice-President; Arthur Pratt was chosen Secretary; and Frank H. Dyer was appointed Treasurer and General Manager. At a meeting of the stockholders, to be held in April, a President is to be chosen, and there is little doubt that Mr. Williams will be the man. Manager Dyer says that the reorganized Company proposes to enlarge the works, extend the mains, and to generally improve the service. The scheme of betterment under consideration involves an expenditure of between \$100,000 to \$150,000, and the work will be completed this summer. It is also proposed to improve and enlarge the electric plant that is operated by the Company.

WE are indebted to Mr. Wm. Daley, Engineer and Manager of the "City of Dunedin Suburban Gas Company (Limited), of Caversham, New Zealand," for the following particulars respecting the workings of the respective gas companies mentioned. The reports go to show that the gas men on the "reverse side" of the world have nothing to complain about: "Wellington, Feb. 3d.—At the annual meeting of the Wellington Gas Company, the report of the Directors, recommending the payment of a further dividend of 6 per cent., making a total of 13½ per cent. for the year, was adopted. The chairman, in moving its adoption and the declaration of the dividend, alluded to the falling off in the consumption of gas through the loss of the street lighting and the general habits of economy made possible by modern improvements, but expressed his confidence that gas will have nothing to fear from competition with electricity in the long run. This was not his opinion alone, but also that of eminent gas engineers in England and America. Christchurch, Feb. 3d.—The Christchurch Gas Company held its 24th annual meeting this afternoon. The balance to credit of profit and loss account was reported as £10,210 5s. 10d. A dividend of 5 per cent. for the half year, making 10 per cent. for the year, was declared, and £210 5s. 10d. carried forward. The retiring Directors, Messrs. John Anderson, H. P. Cowlishaw, Joseph Gould and G. G. Stead were re-elected. In consequence of the reduction in the price of gas the profit is £2,872 less than last year, and £6,537 less than in 1887. Auckland, Feb. 3d.—The Directors of the Auckland Gas Company announced at the annual meeting to-day that the prospects of the Company were so good that they intended to reduce the price of gas from 7s. 6d. to 6s. 8d., or a reduction of 10d. per 1,000 cubic feet. The accounts showed a net profit for the year of £22,086, and there was a balance from last year of £13,169. Dividends were declared as follows: 8s. 6d. per share on fully paid up shares, and 4s. 3d. on half paid up shares, leaving £3,394 to be added to the reserve fund, and £3,310 to be carried forward. Messrs. T. Newman and J. Buddle were re-elected Directors."

MR. RUFUS RAND, Secretary of the Minneapolis (Minn.) Gas Company, denies the rumor that any agreement has been entered into whereby a controlling interest in the Company was to be transferred to an Eastern syndicate.

SAN FRANCISCO parties are negotiating for a franchise for the operation of a gas works in the town of Santa Clara, Cal.

CASE No. 1310, in the Fourth Session Court, Boston, Mass., is that of Jno. Justice vs. the Boston Gas Light Company, and is an action to recover \$4,000 damages to person. Plaintiff asserts in January, 1885, he was employed by the defendant at its branch works at Dorchester, and that while at work, and exercising due care, in "running a machine called an automatic stoker," his right hand was caught in the machine and crushed so seriously as to be rendered useless. He alleges that the accident happened because the room in which he was working was full of steam, caused by the "cooling off or drowning of coke" in the cellar, by which the room was made dangerous to work in. The defence is a general denial. Messrs. C. E. Gerry and A. P. Worthen for plaintiff, with C. P. Greenough and J. P. Parmenter for defence.

ASSISTANT CORPORATION COUNSEL DARROW, of Chicago, has prepared an opinion in which he gives it as his belief that the franchises of the gas companies composing the present Gas Trust can be forfeited to and by the city. Perhaps they (the franchises) can be forfeited, but not according to law. Mr. Darrow also asserts that the city has the right to fix the price of gas.

AN Eastern correspondent writes: "Savin Hill residents, particularly those of them who are yachtsmen, have had their pleasure much disturbed and their eyes offended—these yachtsmen of ours are very delicate fellows—by what they have been pleased to term the unaccountably filthy waters of Dorchester Bay. The "filthy condition" as alleged was traceable to the Bay State Gas Company's station at Commercial Point, but although the Board of Health probed the case, in the evident hope of interfering with the Gas Company, the Board nevertheless failed to satisfy itself that the Company was really at fault. The Company, however, in order to clear itself completely, will not pass any more refuse into the Bay, and will hereafter run its drains into a large settling tank. The cost of the tank will not be less than \$1,000."

THE Bergen County Gas Light Company, of Englewood, New Jersey, has reduced its selling rate to \$2.80. In noting this reduction a local authority says: "This will be satisfactory news to consumers, and I doubt not will lead to an increase in the consumption of gas. The Company's recent and very liberal action in the matter of reducing the rate on gas lamps for the public lighting should meet the hearty approval and support of the public. The erection of the gas works in 1869 was a public spirited venture on the part of our citizens who subscribed the necessary capital, and if they have received no great benefit from their investment, they have at least added to the comfort, convenience and safety of our homes, churches and public halls."

IT is likely that the Courts of Wheeling, West Va., will be appealed to in the settlement of matters arising out of a complaint recently made to the City Council by a number of residents of the Fifth Ward of that city, in which they allege that the Wheeling Electric Light and Railway Company's plant has become a decided nuisance. The plant is located in a rink building which is in a fashionable residence quarter, and petitioners assert that when the machinery is in full operation every building within a radius of 500 feet is badly shaken up. Capt. R. T. Deories, Supt. of the Baltimore and Ohio depot, says that the sleeping hours enjoyed by his family are limited to the time when the electric plant is quiescent.

THE Nebraska Fuel Company, of Omaha, Neb., has been incorporated with a capital stock of \$500,000. The organizers are Messrs. Evan A. Edwards, Robt. Laird, H. A. Biossart, J. D. Cook and J. Sterling Morton. All of these, save the latter, make acknowledgement of the articles in Lucas county, Ohio.

THE plant of the Kingston (Ont.) Gas Company was damaged by fire, on the night of March 20th, in the sum of \$500. There was no interruption to the gas service.

WE understand that articles have been filed which incorporate the Citizens Gas and Electric Company, of Cleveland, O. The incorporators are Jephtha Wade, Jr., Samuel P. Ely, William J. Ramey, Mars E. Waggar and Cyrus P. Leland. An ordinance is now before the Board of

Public Improvements, of Cleveland, granting the Company (which is capitalized in \$250,000) the right to lay gas pipes and to bury subways for electric wires in the streets of the city.

THE main offices of the Minneapolis Gas Company have been removed to the Masonic Temple building.

DESPATCHES from Ottawa, Ills., dated March 21, are to the following effect: "The Illinois Supreme Court to-day denied the rehearing asked for by the Chicago Gas Trust Company in the famous Trust case. The court holds that the pleas filed are insufficient. It is not enough to allege generally that the power of franchise in question was among the powers conferred by the charter. The pleas should set forth particularly and in detail the facts which show how the corporation power or franchise was conferred upon or acquired by the defendant. But if this technical objection be waived the eight pleas are demurrable for reasons which go to merits. Some of them aver that the charter confers the power to purchase 'the capital stock' of other gas companies, which means all the stock of such companies. Others of them are less explicit, but all of them aver that the charter granted power broad enough to authorize the purchase of a majority of the shares of the capital stock of other gas companies, and that under it such majority of shares has been purchased. All of them plead the right to so purchase a majority of said shares as an original and indisputable power or franchise without reference to the other power of making and selling gas. The language of the statements as set out in the pleas imparts an intension to create the Chicago Gas Company for two independent objects. Both were designated as of equal importance and to be carried out independently of each other, the first to build, erect, operate, etc., gas works in the city of Chicago or elsewhere in the State of Illinois; the second to purchase hold or sell the capital stocks or the property and plants and goodwill of other gas companies. The court holds that the manufacture and sale of gas is one business and the dealing in stocks another, and that under the general incorporation law of the State of Illinois a corporation cannot exercise other powers than those concerned in the management of a business for which it received its charter. The dealing in stocks is not a part of the business of the manufacture and sale of gas. The power sought to be conferred by the articles of association of the Chicago Gas Trust Company is something more than the right of purchasing certain stocks of other gas companies. An attempt has been made here to vest them with the tremendous power of the purchase and control, not only of all of the gas companies in Chicago, but in Illinois. This would lead to a suppression of competition and bring about a virtual monopoly. A corporation may be formed for any lawful purpose, but so far as the Gas Trust Company is organized for the purchase of stock of other companies it is not a lawful purpose. The lighting a city is a business of a public character, and any unreasonable restraint placed upon it is prejudicial to the public welfare. This Company seeks to make use of the privileges and franchises of other companies having the use of streets and of public property, and to exercise control of them as though issued by the City Council of Chicago. The public welfare would be endangered should such procedure be authorized."

THE Superintendent of the Empire Gas and Electric Lighting Company of Huntington, L. I., asserts that the financial trouble in which its President (Mr. Claassen, of the Sixth National Bank of this city) is involved, will not affect the Company in any way, and that the gas works will be completed within the time named in the franchise. We hope that such will be the case, although we must confess the current outlook is not in line with that belief, for construction work has been suspended quite a while.

THE proprietors of the Mechanicsburg (Pa.) Gas and Water Company have voted to make application for an amendment to their charter that will permit them to engage in the business of supplying electrical currents for light, heat and power purposes.

MESSRS. DIETERICK, DAWSON AND BENEDICT, of the syndicate that recently secured control of the artificial lighting plants of Indianapolis, Ind., have made a critical examination of their purchase and report themselves as highly pleased. Of course, we did not anticipate any other verdict, more particularly when it is remembered that Mr. J. Sommerville has been for years in control of the most important of the plant factors in the syndicate purchase. We understand that Mr. Fletcher, of the old Indianapolis Gas Company, will not consent to act as President for the Syndicate Company, as he is desirous of seeking recreation in foreign travel. The probability is that a resident of this

city will be named to the Presidency, and that the vice-Presidency and virtual management will be intrusted to residents of Indianapolis.

THE Edison Electric Illuminating Company, of Paterson, N. J., lately brought suit in the District Court against one Jacob Strief, alleging that 7 Edison lamps had been installed on defendant's premises, in consequence of an agreement by the consumer to pay for the service as per "meter bill." The first bill rendered for a month's use amounted to \$34.40, and payment of same was refused. In court defendant maintained that he had never "given an order for the installation of the lights, and that as he did not use them all, he did not see why he should be asked to pay for the installation of the lights and for *more current* than he used." The Court, however, found that even though there was no contract, still his usage of the lights made him responsible for the installation of them, and, of course, he must pay for the amount of current used as indicated by the meter of the Company. This showed the amount claimed (\$34.40) to be correct, and judgment was accordingly given for the plaintiffs.

Recent Patent Issues.

The following list of recent patents relating to the gas interests is specially reported by Franklin H. Hough, solicitor of American and foreign patents, 925 F street, N. W., Washington, D. C.

ISSUE OF MARCH 4, 1890.

- 422,449. Gas Cock Gauge. W. W. Robinson and W. S. Brockway, Milwaukee, Wis.
 422,692. Gas, Apparatus for the Manufacture of. J. D. Averill, Brooklyn, N. Y.
 422,587. Gas Burner, Regenerative. T. Gordon and W. R. Swift, Philadelphia, Pa.
 422,589. Gas Burner, Regenerative. T. Gordon and W. R. Swift, Philadelphia, Pa.
 422,483. Gas Regulator. G. W. Wright, Bapel, Ind.

ISSUE OF MARCH 11, 1890.

- 423,044. Oil Gas, Apparatus for the Manufacture of. W. B. Frink, Revere, Mass.
 423,385. Gas Pipe Alarm. A. Miese, Lima, Ohio.

ISSUE OF MARCH 18, 1890.

- 423,516. Oil Gas, Apparatus for the Manufacture of. H. H. Englemen, Defiance, Ohio.
 423,525. Gas Burner, Self-Lighting. J. W. Lyon, Brooklyn, N. Y.
 423,868. Gas, Production of Chlorine. C. Hornbostel, Brooklyn, N. Y.

ISSUE OF MARCH 25, 1890.

- 424,000. Gas Engine, Rotary. G. E. Hibbard, Chicago, Ills.
 424,027. Gas Engines, Igniting Apparatus for. E. F. Roberts, Rochester, N. Y.
 424,305. Gas or Air Pipes, Safety Device for. E. C. Jones, Boston, Mass.
 424,345. Gas or Oil Motor Engines, Igniting Apparatus for. N. A. Otto, Cologne, Prussia.
 424,199. Gas Regulator. W. Haskell, Smithport, Pa.

The Market for Gas Securities.

The city market for gas shares was featureless during the week, unless utter stagnation may be considered as such. Consolidated sold at 96½ to-day (Friday), which shows that these shares can now hold their own easily in the face of a sluggish market. Other city shares are not inquired after, but all are firmly held, at perhaps a trifle over the ruling nominal quotations. The Brooklyn situation is about as before, with hardly sufficient transactions reported to base quotations on. Baltimore Consolidated has again deceived its friends, and many local speculators are bewailing their fate. They have good reason for this, inasmuch as it was looked upon almost as a certainty that the Senate would indorse the action of the House in passing the bill regulating the gas supply of that city for a term of years. The Senate, however, has "indefinitely postponed" the bill, which means its death.

Eastern shareholders are agitated over the prospects of opposition at Providence and Pawtucket, R. I., mention of which scheme will be found in our Editorial columns. After awhile perhaps the gas stockholders will appeal to the lawmaking power to protect them from such strikes by the formation of Commissions similar to the Massachusetts system. The strikers are again at work in the direction of Washington, D. C., but it is not likely that they will be any more successful than those who have tried the same game in the past.



A. M. CALLENDER & CO.,

PROPRIETORS.

EDITOR—JOS. R. THOMAS, C.E.

ASST. EDITOR—T. J. CUNNINGHAM.

MANAGER—C. E. SANDERSON.

PUBLISHED ON EACH MONDAY OF THE YEAR AT
No. 42 Pine Street, New York.

This is a recognized official organ of
LIGHT, HEAT, STEAM, WATER SUPPLY,

VENTILATION, SANITARY IMPROVEMENT,
AND GENERAL SCIENCE

TERMS:

SUBSCRIPTION—Three Dollars per annum, in advance. Single copies, 10 cents.

AGENTS.

NEW YORK.—AMERICAN NEWS CO., 39 and 41 Chambers Street.
PHILADELPHIA.—PRATT & CO., Corner Ninth and Arch Streets.
Germany.—B. WESTERMANN & CO., of New York.

MONDAY, MARCH 31, 1890.

Gas Stocks.

Quotations by Geo. W. Close, Broker and Dealer in Gas Stocks.

16 WALL ST., NEW YORK CITY.

MARCH 31.

All communications will receive particular attention.
The following quotations are based on the par value of \$100 per share.

	Capital.	Par.	Bid	Asked
Consolidated.....	\$35,430,000	100	96½	—
Central.....	500,000	50	—	—
“ Scrip.....	220,000	—	—	—
Equitable.....	4,000,000	100	117	120
“ Bonds.....	1,000,000	—	113	115
Harlem, Bonds.....	170,000	—	—	—
Metropolitan, Bonds....	658,000	—	116	118
Mutual.....	3,500,000	100	109	—
“ Bonds.....	1,500,000	—	100	102
Municipal, Bonds.....	750,000	—	—	—
Northern.....	—	50	—	—
“ Bonds.....	150,000	—	—	100
Standard Gas Co.—				
Common Stock.....	5,000,000	100	—	45
Preferred.....	5,000,000	100	84	87
Yonkers.....	—	50	112	—
Richmond Co., S. I....	346,000	50	—	—
“ Bonds.....	20,000	—	—	—
Gas Co's of Brooklyn.				
Brooklyn.....	2,000,000	25	109	111
Citizens.....	1,200,000	20	68	70
“ S. F. Bonds....	320,000	1000	102	103
Fulton Municipal.....	3,000,000	100	124	126
“ Bonds....	300,000	—	105	—
Peoples.....	1,000,000	10	80	82
“ Bonds (5's).....	368,000	—	100	—
“ “ (6's).....	94,000	—	100	—
Metropolitan.....	1,000,000	100	100	—
Nassau.....	1,000,000	25	119	—
“ Cfts.....	700,000	1000	100	102
Williamsburgh.....	1,000,000	50	123	125
“ Bonds... ..	1,000,000	—	108	112
Out of Town Gas Companies.				
Boston United Gas Co.—				
1st Series S.F. Trust	7,000,000	1000	93	93½
2d “ “ “	3,000,000	1000	71	72

Bay State Gas Co.—				
Stock.....	5,000,000	50	24	25
Income Bonds.....	2,000,000	1000	—	—
Buffalo Mutual, N. Y....	750,000	100	90	95
“ Bonds... ..	200,000	1000	95	100
Citizens, Newark.....	1,000,000	50	155	160
“ “ Bonds.....	45,000	—	—	—
Chicago Gas Trust.....	25,000,000	100	43	—
Chicago Gas Light. & Coke Co.—				
G't'd Gold Bonds	7,650,000	1000	—	93½
Equitable Gas & Fuel Co., Chicago, Bonds	2,000,000	1000	—	102
People's Gas and Coke Co., Chicago—				
1st Mortgage.....	2,100,000	1000	—	100
2d “	2,500,000	1000	96	100
Consumers Gas Light Co., Jersey City.....	2,000,000	100	15	25
Bonds.....	600,000	1000	80	—
Cincinnati G. & C. Co..	6,000,000	100	201	203
Consumers Toronto....	1,000,000	50	190	200
Central, S. F., Cal.....	—	—	80	90
Capital, Sacramento, Cal	—	—	58	—
Consolidated, Balt.....	11,000,000	100	—	43
“ Bonds.....	6,400,000	—	107	107½
Citizens Gas Lt. Co., Rochester, N. Y.....	500,000	—	75	90
Bonds.....	250,000	—	—	—
Hartford, Conn.....	750,000	25	102	108
Jersey City.....	750,000	20	186	190
Laclede Gas Light Co., St. Louis, Mo.—				
Common Stock....	7,500,000	100	14	17
Preferred “	2,500,000	100	—	—
Bonds.....	9,034,400	1000	81½	82½
Louisville, Ky.....	2,570,000	50	125	130
Little Falls, N. Y.....	50,000	100	—	100
“ Bonds	25,000	—	100	103
Montreal, Canada.....	2,000,000	100	200	208
Memphis (Tenn.) Gas... ..	750,000	100	48	51
“ Bonds.....	240,000	100	103	—
New Haven, Conn.....	—	25	200	—
Oakland, Cal.....	—	—	35	35½
Peoples, Jersey City... ..	—	—	60	61
“ “ Bonds..	—	—	—	—
Paterson, N. J.....	—	25	99	102
Rochester, N. Y.....	—	50	99	100
Syracuse, N. Y.....	500,000	25	—	—
San Francisco Gas Co.				
San Francisco, Cal....	10,000,000	100	55½	55¾
Washington, D. C.....	2,000,000	20	200	208
Wilmington, Del.....	—	50	88	90

Advertisers Index.

GAS ENGINEERS.	Page
Jos. R. Thomas, New York City	452
Wm. Henry White, New York City.....	455
Wm. Mooney, New York City.....	452
William Gardner, Pittsburgh, Pa.....	452
Fred. Bredel, N. Y. City.....	451
GAS WORKS APPARATUS AND CONSTRUCTION.	
James R. Floyd & Sons, New York City	455
Continental Iron Works, Greenpoint, L. I.	455
Delly & Fowler, Phila., Pa.....	455
Kerr Murray Mfg. Co., Fort Wayne, Ind.....	443
Stacey Mfg. Co., Cincinnati, Ohio.....	455
Bartlett, Hayward & Co., Baltimore, Md.....	453
Morris, Tasker & Co., Limited, Phila., Pa.....	453
Davis & Farnum Mfg. Co., Waltham, Mass.....	443
R. D. Wood & Co., Phila., Pa.....	454
Bouton Foundry Co., Chicago, Ills.....	455
Smith & Sayre Manufacturing Co., New York City.....	454
Fred. Bredel, N. Y. City.....	451
United Gas Improvement Co., Phila., Pa.....	445
National Gas Light and Fuel Co., Chicago, Ills.....	442
Simpkin & Hillyer, Richmond, Va.	439
GAS AND WATER PIPES.	
Gloucester Iron Works, Phila., Pa.....	452
Mellert Foundry and Machine Co., Reading, Pa. (John Fox, Selling Agent, N. Y.).....	452
Ohio Pipe Co., Columbus, Ohio.....	452
M. J. Drummond, New York City.....	452
R. D. Wood & Co., Phila., Pa.....	454
Warren Foundry & Machine Co., New York City.....	452
Donaldson Iron Co., Etna, Pa.....	452
Dennis Long & Company, Louisville, Ky.....	452

PROCESSES.	
National Gas Light and Fuel Co., Chicago, Ills.....	442
Bartlett, Hayward & Co., Baltimore, Md.....	453
Wm. Henry White, N. Y. City.....	455
United Gas Improvement Co., Phila., Pa.....	445
The Fuel Gas and Light Improvement Co., N. Y. City.....	440
INCLINED RETORTS.	
Laclede Fire Brick Manuf'g Co., St. Louis, Mo.....	407
GASHOLDER TANKS.	
W. C. Whyte, New York City.. ..	442
J. P. Whittier, Brooklyn, N. Y.....	447
GASHOLDER PAINT.	
The Government Waterproof Paint Co., Boston, Mass.....	440
RETORTS AND FIREBRICK.	
J. H. Gautier & Co., Jersey City, N. J....	450
B. Kreischer & Sons, New York City... ..	450
Adam Weber, New York City.....	450
Laclede Fire Brick Manuf'g Co., St. Louis, Mo.....	450
Brooklyn Retort and Fire Brick Works, Brooklyn, N. Y.....	450
Borgner & O'Brien, Phila., Pa.....	450
James Gardner, Jr., Pittsburgh, Pa.....	450
Henry Maurer & Son, New York City.....	451
Chicago Retort and Fire Brick Co., Chicago, Ills.....	450
Baltimore Retort and Fire Brick Co., Baltimore.....	450
Oakhill Gas Retort and Fire Brick Co., St. Louis, Mo. . .	450
Boston Fire Brick Works, Boston, Mass.....	450
SCRUBBERS AND CONDENSERS.	
G. Shepard Page, New York City . . .	408
R. D. Wood & Co., Phila., Pa.....	454
REGENERATIVE FURNACES.	
Bartlett, Hayward & Co., Baltimore, Md.....	453
Fred. Bredel, New York City . . .	451
Chicago Retort and Firebrick Co., Chicago, Ills.....	450
Wm. Henry White, N. Y. City.....	455
J. H. Gautier & Co., Jersey City, N. J.....	451
GAS GOVERNORS.	
Connelly & Co., New York City.....	447
Fred. Bredel, N. Y. City.....	451
Friedrich Lux, London, England.. .	439
SELF-SEALING MOUTHPIECE DOORS.	
Smith & Sayre Mfg. Co., New York City.....	454
TAR AND CARBONIC ACID EXTRACTOR.	
Geo. Shepard Page, N. Y. City.....	444
CEMENTS.	
C. L. Gerould & Co., Brooklyn, N. Y.....	450
GAS ENRICHERS.	
Staudard Oil Co., Cleveland, Ohio.....	456
GAS METERS.	
John J. Griffin & Co., Phila., Pa.....	458
American Meter Co., New York and Philadelphia.....	459
The Goodwin Gas Stove and Meter Co., Philadelphia, Pa. . .	459
Helme & McIlhenny, Phila., Pa.....	459
D. McDonald & Co., Albany, N. Y.....	459
Nathaniel Tufts, Boston, Mass.....	458
Maryland Meter and Manufacturing Co., Baltimore, Md. . .	440
Bell & Jones, Philadelphia, Pa.....	458
Harris Bros. & Co., Philadelphia, Pa.	458
EXHAUSTERS.	
The P. H. & F. M. Roots Co., Connersville, Ind.....	446
Smith & Sayre Manufacturing Co., New York City.....	454
Wilbraham Bros., Philadelphia, Pa.....	447
Connelly & Co., New York City.....	447
GAS COALS.	
Penn Gas Coal Co., Phila., Pa.	457
Perkins & Co., New York City.....	456
Newburgh Orrel Coal Co., Baltimore Md.....	457
Despard Coal Co., Baltimore, Md.....	457
Chesapeake and Ohio R. R. Coal Agency, N. Y. City.....	457
Westmoreland Coal Company, Phila., Pa.....	457
J. & W. Wood, New York City.....	456
CANNEL COALS.	
Perkins & Co., New York City.....	456
J. & W. Wood, New York City.....	456
VALVES.	
Ludlow Valve Manufacturing Co., Troy, N. Y.....	448
John McLean, New York City.	448
Chapman Valve Manufacturing Co., Boston, Mass.....	448
R. D. Wood & Co., Phila., Pa.....	454
The P. H. & F. M. Roots Co., Connersville, Ind.....	446
GAS ENGINES.	
Schleicher, Schumm & Co., Phila., Pa.....	424
Clerk Gas Engine Co., Phila., Pa.....	448
Van Duzen Gas Engine Co., Cincinnati, Ohio.....	448
ENGINES AND BOILERS.	
Jarvis Engineering Co., Boston, Mass.....	447
Ball Engine Co., Erie, Pa.....	440
Westinghouse Machine Co., Pittsburgh, Pa.....	451

GAS LAMPS.

G. Shepard Page, New York City. 418
 Welsbach Incandescent Gas Light Co., Phila., Pa. 441
 The Siemens-Lungren Company, Philadelphia, Pa. 441
 Fiske, Coleman & Company, Boston, Mass. 450

PURIFIER SCREENS.

John Cabot, New York City. 448
 Bartlett, Hayward & Co., Baltimore, Md. 448

GAS STOVES.

American Meter Co., New York and Philadelphia. 449
 The Goodwin Gas Stove and Meter Co., Phila. Pa. 460
 George M. Clark & Company, Chicago, Ills. 441
 D. McDonald & Co., Albany, N. Y. 459
 Maryland Meter and Manufacturing Co., Baltimore, Md. 440
 Bell & Jones, Philadelphia, Pa. 458
 Chicago Gas Stove Company, Chicago, Ills. 140

STREET LAMPS.

J. G. Miner, Morrisania, New York City. 403
 Bartlett Street Lamp Man'g Co., New York City 439

BURNERS.

C. A. Gefroerer, Phila., Pa. 456
 H. W. Rappleye, Philadelphia, Pa. 368

STEAM BLOWER FOR BURNING BREESE.

H. E. Parson, New York City. 412

PURIFYING MATERIAL.

Counelly & Co., New York City. 447
 Friedrich Lux, London, England. 439
 Edgewater Lime Works, Edgewater, N. J. 439

COKE CRUSHER.

C. M. Keller, Columbus, Ind. 457

ELECTRICAL APPARATUS.

Wm. Henry White, N. Y. City. 455

BOOKS, ETC.

Gerould's System Gas Bookkeeping. 440
 1889. Directory. 1889. 447
 King's Treatise 452
 Scientific Books. 450
 Management of Small Gas Works 448
 Gas vs. Electricity 340
 Practical Electric Lighting. 447
 Electric Light Primer. 447
 American Gas Engineer and Superintendents' Handbook. 457
 Digest of Gas Law. 439
 Fuel and its Applications 439
 Newbigging's Handbook 451

POSITION WANTED.

A Mechanical Engineer,

Experienced in Gas Manufacture, wishes a position as Superintendent of a Gas Works. Best of references given and asked. Salary, \$1,200.

"MECHANICAL ENGINEER," care this Journal, 765-tf or Box 972, West Bay City, Mich

FOR SALE,

The Ironwork for 11 Benches of 5's, viz.:
Cast Iron Hydraulic Mains, 17 inch diameter, inside.
Dip Pipes, Bridge Pipes, Stand Pipes,
Mouthpieces and Lids.
Four Purifiers, 10 by 16 ft., with 10-inch Connections and dry Center Seal.
Four Purifiers, 5½ by 10 ft., with 6-inch Connections and Wet Center Seal.
Valves, 6-inch, 8-inch, and 10-inch.
 DAVID MOORE, Treas. Salem Gas Lt. Co., 770-tf Salem, Mass.

GAS WORKS FOR SALE.

A CONTROLLING INTEREST IN SEVERAL

Interior California Coal Gas Plants,

now paying handsomely, are offered on very reasonable terms. This is an exceptionally good opportunity for practical gas men of limited means, wishing to remove to a mild and healthful climate, to acquire an established and paying business. Particulars given and full investigation solicited.

SECRETARY, 123 Beale Street, San Francisco, Cal.

For Sale, Cheap.

Thirty Benches of 5's, with Cast Iron Hydraulic Main, 5-inch Stand and Dip Pipes, Plugs, etc Also,
Stays and Rods for Forty Benches, with Door Frames and Doors, Mouthpieces, Lids, Cotter Bars, etc.
Four Iron 4-Wheel Side-Drop Retort House Coke Wagons. Four Good Coal Carts.
Twelve Charging Scoops. Hoes, Rakes, and Firing Tools.
One Set Round Purifiers, 10 ft. diameter, 12-in. Seal, with Wet Center Seal.
Washers, Scrubbers, and
One Mackenzie Exhauster, 12-in. openings, 500,000 cu. ft. capacity.
 Will sell whole or in part, to suit purchaser. Address 772-tf MUNICIPAL GAS CO., Albany, N. Y.

FOR SALE,

The Ironwork for Twelve Benches of 6's, viz.:
Cast Iron Hydraulic Main.
7-inch Dip-Pipes, Stand-Pipes, and Bridge-Pipes, complete.
Floyd Mouthpieces and Self-Sealing Lids, 15x26 in. Lids and Mouthpieces only in use over a year. Will be sold cheap. ISAAC C. BAXTER, 772-tf Detroit (Mich.) Gas Lt. Co.

FOR SALE.

A Complete Water Gas Plant.
60,000 Cu. Ft. Daily Capacity.

Fully equipped; all the latest improvements; includes Generator, Purifiers, and Holder. Can be removed to any part of the country, and set up at small cost. For further information apply to BRADFORD GAS LT. & HEATING CO., Dunkirk, N. Y

6 PER CENT.

First Mortgage Bonds

ON GAS WORKS

SITUATED IN GROWING WESTERN TOWNS.

Principal and Interest Guaranteed.

INTEREST SEMI-ANNUALLY.

For sale by the undersigned, who will furnish all necessary information regarding them.

JOS. R. THOMAS, 42 Pine St., N. Y. City.

Fuel and Its Applications.

By E. J. MILLS, D.Sc. F.R.S., and F. J. ROWAN, C.E., assisted by others, including Mr. F. P. Dewey, of the Smithsonian Inst., Wash., D. C.

7 PLATES, AND 607 OTHER ILLUSTRATIONS. ROYAL OCTAVO, PAGES XX, 802. HANDSOME CLOTH, \$7.50.

A. M. CALLENDER & CO., 42 Pine St., N. Y.

FRIEDRICH LUX,

Ludwigshafen am Rhein and London.

Lux Mass

GAS GOVERNORS,

Gas Balance.

Bartlett Street Lamp Mfg. Co.

MANUFACTURERS OF

Globe Lamps,

FOR

Streets, Parks, Public Buildings, Railroad Stations, etc.

LAMP POSTS

A Specialty.

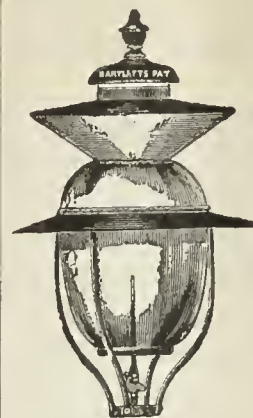

Office and Salesroom,

40 & 42 COLLEGE PLACE, - - N. Y. CITY.

Gas Companies and others intending to erect Lamps and Posts will do well to communicate with us.

EDGEWATER LIME WORKS

Chas. F. McKenna, Proprietor.

SHELL LIME.

Lime by the Cargo for Gas Purification.

EDGEWATER, BERGEN CO., N. J.

Write for Testimonials and Prices.

Simpkin & Hillyer

RICHMOND, VA.

MANUFACTURERS OF

Gas Works Apparatus

BENCH CASTINGS, CONDENSERS,

Scrubbers, Purifiers, Dry Center Seals,

FOUR-WAY VALVES, GAS VALVES,

SULPHATE OF AMMONIA APPARATUS,

TANKS, ENGINES, BOILERS,

PUMPS, ETC., ETC.

Plans, Specifications and Estimates furnished for new works, or alteration of old works. Correspondence solicited. Works, Newport News, Va.

GREENOUGH'S

"DIGEST OF GAS LAW."

Price, \$5.00.

This is a valuable and important work, a copy of which should be in the possession of every gas company in the country, whether large or small. As a book of reference it will be found invaluable. It is the only work of the kind which has ever been published in this country, and is most complete. Handsomely bound. Orders may be sent to

A. M. CALLENDER & CO.,

42 Pine Street, N. Y.

F. D. HARMON, PRES.

CHAS. C. ALLEN, SEC. AND TREAS.

P. W. MACKENZIE, CHIEF ENGR. & SUPT.

THE FUEL GAS AND LIGHT IMPROVEMENT CO.

OF AMERICA.

Owner of the Mackenzie Patents of Dec. 31, 1889,

For the United States, England, Russia, France, Germany, Austria, and Canada,

No. 32 Park Place, New York City.

This SYSTEM is an ABSOLUTELY NEW DEPARTURE IN THE MANUFACTURE OF FUEL AND ILLUMINATING GAS. The COST OF GAS IN THE HOLDER by our System is at least THIRTY PER CENT. LESS than that made by any other process of the day. The Gas contains neither SULPHUR nor other impurities, nor is there any resultant LAMPBLACK OR TAR RESIDUUM. The Gas is manufactured WHOLLY from LIQUID HYDROCARBONS, such as Lima, Penn. Crude, and Fuel Oils, Naphtha, etc. Neither PERISHABLE PIPES nor other RETORTS, NOR THEIR EQUIVALENTS, are used. The Gas requires NO PURIFICATION. Neither COAL, COKE, nor any other HARD CARBONS enter into the manufacture or composition of the Gas, thereby requiring LESS LABOR THAN ANY OTHER METHOD. The APPARATUS is extremely SIMPLE, SUBSTANTIAL, and DURABLE. Works under our system can be CONTINUOUS or ALTERNATING. If alternating, the Nitrogen present will be less than 4½ per cent. If continuous, the limited amount of Nitrogen present is neutralized by Carbon. One gallon of Lima oil by our process EQUALS ALL THE COAL required for making 1,000 feet of carbureted Water Gas.

CHARLES E. DICKEY.

JAMES B. SMALLWOOD.

CHARLES H. DICKEY.

THE MARYLAND METER AND MANUFACTURING CO.

Established 1866.

BALTIMORE, North & Saratoga Sts.

CHICAGO, 197 Michigan Street.

NEW YORK, 766 Broadway.

BOSTON, 4 Central Street.

ST. LOUIS, 1115 Olive Street.

SAN FRANCISCO, 330 Pine Street.

CONSUMERS' & STATION METERS, PRESSURE GAUGES, Etc., Etc.

"Success" and "Perfect" Gas Stoves.

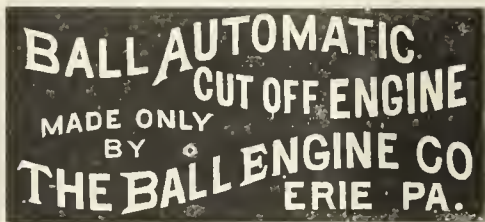

GASHOLDER PAINT.

Use Only

THE GOVERNMENT WATERPROOF PAINT.

Proof against Ammonia, and Absolutely Waterproof. Send for Prices and Particulars.

THE GOVERNMENT WATERPROOF PAINT CO., 122 Milk Street, Boston, Mass.

GEROULD'S

System Gas Bookkeeping.

Approved and adopted by many of the prominent Gas Engineers of the Country.

Sample Sheets and Price-List furnished free on application to

L. P. GEROULD, - - Mendota, Ill.

GAS vs. ELECTRIC LIGHT.

We would invite attention to the able and exhaustive argument of General A. Hickenlooper, President of the Cincinnati Gas Light and Coke Company, contained in a handsome pamphlet of 96 pages, entitled

"EDISON'S INCANDESCENT ELECTRIC LIGHTS FOR STREET ILLUMINATION. REPORT OF AN ARGUMENT DELIVERED BY A. HICKENLOOPER BEFORE THE COMMITTEE ON LIGHT, MUNICIPAL COUNCIL, CITY OF CINCINNATI, JULY 22, 1886."

This is a subject of special interest to all Gas Light Companies.

Prices.

25 copies.....	\$7.50	100 copies.....	\$22.50
50 copies.....	12.50	250 copies.....	50.00

A sample copy will be sent by mail on receipt of 50 cts

A. M. CALLENDER, & CO., 42 PINE ST., N. Y. CITY

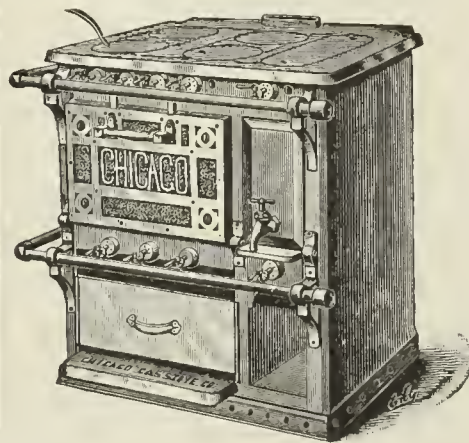

CHICAGO GAS STOVE CO.

MANUFACTURERS OF ALL KINDS OF

Gas Cooking and Heating

APPLIANCES.

117-119 Lake St., CHICAGO.

Send for Catalogue.

PATENTS.

FRANKLIN H. HOUGH

Solicitor of American & Foreign Patents.

925 F. ST., WASHINGTON, D. C.

(NEAR U. S. PATENT OFFICE.)

Personal attention given to the preparation and prosecution of applications for Letters Patent. All business before the U. S. Patent Office attended to for moderate fees. **No Agency in the United States possesses superior facilities for obtaining Patents,** or for ascertaining the patentability of inventions. Copies of patents furnished for 25 cents each. Correspondence solicited.

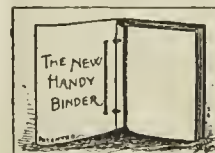

THE NEW HANDY BINDER.

This article may be described as elegant in appearance, strong, durable, and possessing many special qualities of its own. It allows the opening of the pages perfectly flat, whether one or several numbers are in the binder. Any number can be taken out and replaced without disturbing the others. The papers are not mutilated for subsequent binding in permanent form. The binder is supplied with gilt side title, and is an ornament to any desk or reading table. The JOURNAL, filed in the Handy Binder, becomes a volume of great value, always convenient for instant reference. **Handy Binder, Postage paid, \$1.00.**

A. M. CALLENDER & CO., 42 Pine St., N. Y.

The Gordon Portico Lamp.

A successful Competitor of the Arc Electric Light for lighting Store Fronts, Show Windows, Depots, Railway Sheds, etc., etc.

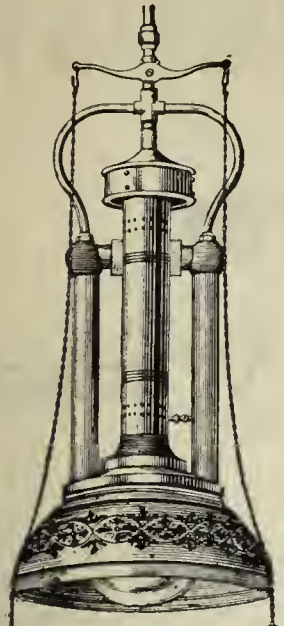

Gordon Portico Lamp.

The Gordon Street Lamp.

A Successful Competitor of the Arc Electric Light for lighting Streets, etc., etc.

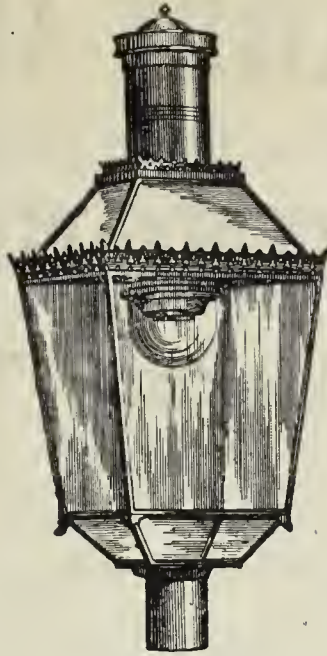

Gordon Street Lamp.

The Lungren Lamp.

A Successful Competitor of the Incandescent Electric Light for Interiors, etc. Is especially applicable for the lighting of Offices, Stores, Factories, Mills, Show Windows, Libraries, and all situations where an increased illumination is desired.

More than 25,000 Lungren Lamps are now in use. Testimonials, references, or any desired information will be cheerfully given.



Lungren Lamp.

THE SIEMENS-LUNGREN CO., N.E. Cor. 21st St. & Washington Av., PHILADELPHIA.

WELSBACH SYSTEM OF Incandescent Gas Lighting.

OFFICE, DREXEL BUILDING, PHILA., PA.

At the Fall Session of the Board of Supervisors of Winnebago County, held at the County Court House, Oshkosh, Wis., Nov. 26, 1889, the report submitted by Mr. C. W. Cook, Chairman of the Committee on Public Buildings, recommending the use of the Welsbach Incandescent Gas Burner in the Buildings under their charge, was unanimously adopted, because of the extreme economy in the consumption of Gas and the superior character of the light obtained.

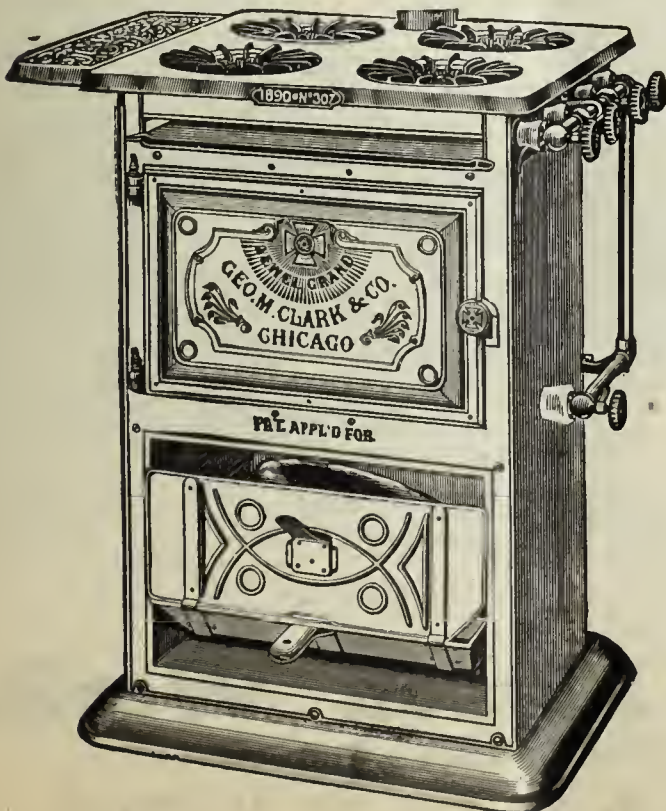

JEWEL GAS STOVES

MANUFACTURED BY

GEORGE M. CLARK & COMPANY,

Nos. 157 & 159 Superior Street, - - - Chicago, Ill.

EVERY CONCEIVABLE SIZE AND STYLE,

Ranging in Prices from \$1.50 to \$30.00.

WE USE NO GAS COCKS.

All Flames are Regulated by a Direct Needle Valve.

The JEWEL

IS THE

Only Well-Made Gas Stove on the Market.

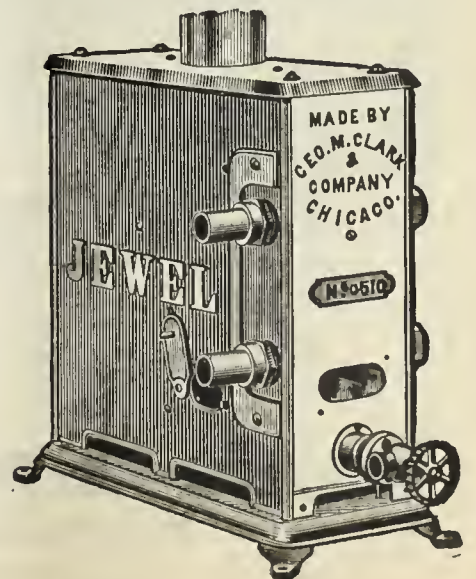

Write for our 1890 Catalogue and see for yourself.

NATIONAL GAS LIGHT AND FUEL COMPANY,

No. 218 La Salle Street, Chicago.

THE SPRINGER SYSTEM

OF

Fuel and Illuminating Water Gas Works.

REFERENCES.

People's Gas Lt. & Coke Co.. Chicago, Ill.
 Illinois Light, Heat & Power
 Co..... Chicago, Ill
 Elgin National Watch Co... Elgin, Ill.
 C. R. I. & P. R. R. Shops.. Chicago, Ill.
 Decatur Gas Lt & Coke Co.. Decatur, Ill.
 Niles Gas Light Co..... Niles, Mich.
 Newton Illuminating Co... Newton, Kansas.
 Wellington Light & Heat Co.. Wellington, Kansas.
 Chippewa Falls Gas Lt. Co.. Chippewa Falls, Wis.
 Elkhart Gas Lt & Coke Co.. Elkhart, Ind.
 Madison City Gas Light Co. Madison, Wis.
 South Bend Gas Light Co.. South Bend, Ind.
 Sheboygan National Gas Co. Sheboygan, Wis.
 Salina Gas Light Co..... Salina, Kansas.
 The Rathbun Co..... Deseronto, Prov. Ont.
 Jefferson City Gas Lt. Co.. Jefferson City, Mo.
 Mankato Gas Light Co.... Mankato, Minn.
 Lima Gas Light Co..... Lima, Ohio.

Minneapolis Gas Light and
 Coke Co..... Minneapolis, Minn.
 Bellevue Water and Fuel } Bellevue, Campbell
 Gas Light Co..... } County, Ky.
 Bucyrus Gas Lt. & Fuel Co. Bucyrus, Ohio.
 Morris Gas Co..... Morris, Ill.
 Los Angeles Gas Co..... Los Angeles, Cal.
 San Diego Gas Fuel & Elec-
 tric Lt. Co..... San Diego, Cal.
 Sioux Falls Gas Co..... Sioux Falls, Dak.
 Dakota Gas and Fuel Co.. Grand Forks, Dak.
 St. Johns Mutual Gas Co.. St. Johns, Mich.
 Stillwater Gas Light Co... Stillwater, Minn.
 St. Paul Gas Light Co.... St. Paul, Minn.
 Emporia Electric and Gas
 Light Co..... Emporia, Kas.
 Van Wert Gas Light Co... Van Wert, Ohio.
 Lansing Gas Light Co.... Lansing, Mich.
 San Francisco Gas Lt. Co.. San Francisco, Cal.

Shelbyville Gas Light Co... Shelbyville, Ind.
 Great Falls Gas Light Co.. Great Falls, N. H.
 Belleville Gas Co..... Belleville, Ontario
 Rochester Lt. and Fuel Co.. Rochester, Minn.
 Northwestern Gas Light and
 Coke Co..... Evanston, Ill.
 Lincoln Gas Light Co..... Lincoln, Neb.
 Davenport Gas Light Co... Davenport, Iowa.
 Municipal Gas Co..... Albany, N. Y.
 Alliance Gas Light Co..... Alliance, Ohio.
 New Gas Light Co..... Janesville, Wis.
 Chicago Gas Lt. & Coke Co., Chicago, Ill.
 Joliet Gas Co..... Joliet, Ills.
 Superior Light & Fuel Co.. Superior, Wis.
 Kewanee Gas Light Co... Kewanee, Ill.
 Aberdeen Light & Fuel Co.. Aberdeen, So. Dak.
 Pierre Light and Fuel Co.. Pierre, So. Dak.
 *Standard Gas Light Co... New York City.
 *Carlinville Gas Light Co.. Carlinville, Ill.

* Building.

GUARANTEED ESTIMATES of Cost of Gas Furnished on Application.

GASHOLDER TANK CONSTRUCTION, ETC.

Gas Companies and others about to erect Gasholders will find it profitable to consult
 W. C. Whyte, who for over 30 years has made a specialty of

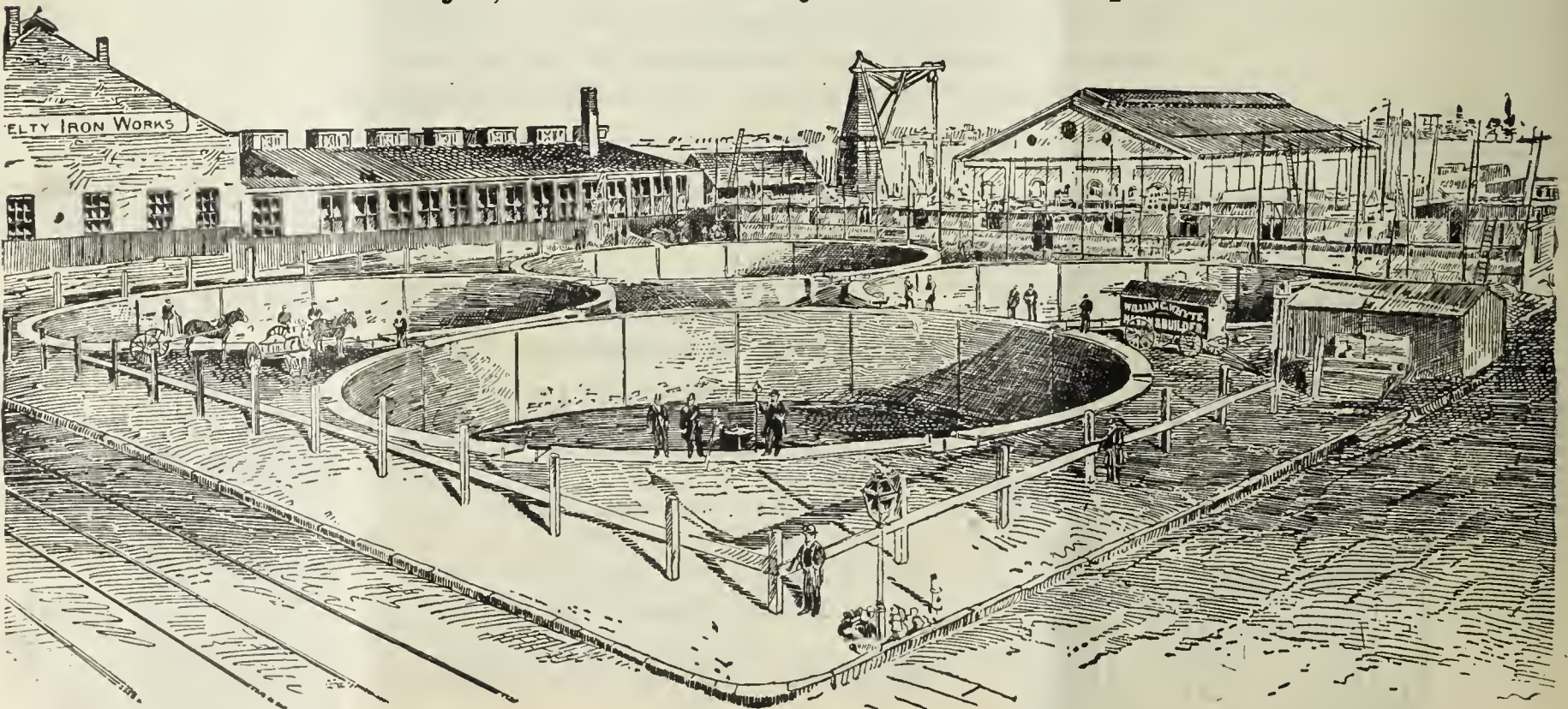

Tank Excavation and Mason Work.

Fifty Tanks now in operation show the sort of work done. Address

W. C. WHYTE, - No. 15 Cortlandt Street, N. Y. City.

THIS SPACE
WILL BE
Occupied Next Month by the
KERR MURRAY MFG. CO.
FORT WAYNE, IND.
**GAS WORKS
APPARATUS
AND
HOLDERS.**

**DAVIS & FARNUM MFG. CO.,
WALTHAM, MASS.**

PRINCIPAL OFFICE AND WORKS, Waltham, Mass.

BOSTON OFFICE, Room 55, Mason Building, 70 Kilby Street.

SINGLE, DOUBLE,
AND
TRIPLE LIFT

Gas holders.

OF ANY CAPACITY.



TUBULAR, PIPE,
AND
SINUOUS FRICTION

Condensers.

OF ALL SIZES.

IRON ROOF FRAMES AND FLOORS.

Purifying Boxes, Center Seal or Valve Connections, Bench Work.

Reversible Lime Trays.

SELF-SEALING AND PRESSED STEEL MOUTHPIECE LIDS.

Coke Barrows, Coal Wagons, and all Apparatus Requisite for a Complete Gas Plant.

— ALSO —

Gas and Water Pipe, Flanged Pipe,

Sugar House Work, and Special Castings of all Descriptions.

THE WALKER TAR AND CARBONIC ACID EXTRACTOR.

A very general demand exists, in both large and small Gas Works, for an apparatus that will be absolutely efficient in the removal of the tar which passes the hydraulic main and condenser. Many attempts have been made to accomplish this, but, I believe, without success, until the introduction, five years ago, in England, of the C. & W. Walker Patent Tar and Carbonic Acid Extractor. During these years this apparatus has been adopted by many of the most prominent Engineers, not only in England, but also on the Continent of Europe and in other parts of the world. It is only necessary to give here a partial list in order to convince any intelligent American Gas Engineer that this machine must have succeeded fully in accomplishing the desired results.

The following Engineers have personally given permission to refer to them:

G. C. Trewby, Esq., Engineer-in-Chief of the Gas Light and Coke Co., London. The manufacturing plant at Beckton is built in complete sections of 3,000,000 cubic feet capacity each. A Walker Tar Extractor has been fitted to each one of these sections. This was done after a long and thorough trial on one of its sections. The Tar Extractor has been supplied to other works of the Gas Light and Coke Co., including those of which John Methven, Engineer of the Gas Light and Coke Co. at the Nine Elms Station, is in charge. Also to G. E. Stevenson, Peterborough Gas Works; B. Green, Mitcham and Wimbledon Gas Works; W. H. Smith, Bedford Gas Works; F. Linging, Norwich Gas Works; J. T. Browning, Colchester Gas Works; S. B. Darwin, Portsmouth Gas Works; J. McCrae, Dundee Gas Works; W. J. Wells, Stamford Gas Works; J. M. Darwin, Longton Gas Works; J. Paterson, Warrington Gas Works; and J. Coulter, of the Dundalk Gas Works. All of the foregoing gas works are located in Great Britain.

Mr. Charles A. Gerdenier, Superintendent of the Bridgeport (Conn.) Gas Light Company, writes as follows, under date of Dec. 3, 1887:

"The C. & W. Walker Tar and Carbonic Acid Extractor has been in operation at these works for the past six weeks, and is an unqualified success. It removes every particle of Tar from the gas in once passing through the apparatus, and a large percentage of the Carbonic Acid. I also feel quite sure that it prevents the formation and deposit of Naphthaline, because since I started the Washer I have had no stoppages from this cause. These works have been seriously troubled with Tar for many years, and I have used several kinds of apparatus and every expedient which has come to my attention for dealing with the difficulty, but without success. The Walker apparatus occupies comparatively small space, is less expensive than other systems, and requires but little attention. I carry 2½-inch seal, and have an automatic tar delivery valve. This Tar Extractor is indispensable to gas makers."

I have taken the Agency for the United States for this apparatus, and am now prepared to make contracts to erect it on the premises of any Gas Company. It would be manufactured in the following sizes:

No. 1,	50,000 to	100,000	cu. ft. per 24 hrs.,	3	ft. square,	5	ft. deep.		
No. 2,	"	"	125,000	"	"	"	"	"	"
No. 3,	"	"	250,000	"	"	"	"	"	"
No. 4,	"	"	500,000	"	"	"	"	"	"
No. 5,	"	"	750,000	"	"	"	"	"	"
No. 6,	"	"	1,000,000	"	"	"	"	"	"
No. 7,	"	"	1,250,000	"	"	"	"	"	"
No. 8,	"	"	1,500,000	"	"	"	10	"	"
No. 9,	"	"	2,000,000	"	"	"	12	"	"
No. 10,	"	"	3,000,000	"	"	"	15	"	"

This Tar Extractor will perform its work with about one-fourth the usual back-pressure heretofore required. It is simple in construction, and can be supplied at a very reasonable price—less than any other ever before introduced. Satisfactory results will be guaranteed in every instance.

GEO. SHEPARD PAGE,

SOLE AGENT FOR THE UNITED STATES,

No. 69 Wall Street, - - - New York.

THE UNITED GAS IMPROVEMENT CO.

Drexel Building,

CHESTNUT AND FIFTH STREETS,

PHILADELPHIA, PA.

OFFICERS:

WILLIAM W. GIBBS, President.

GEORGE PHILLER, Vice-President.

SAML T. BODINE, Gen'l Manager.

RANDAL MORGAN, Gen'l Counsel.

EDWARD C. LEE, Sec'y and Treas.

ALEX. C. HUMPHREYS, Gen'l Supt.

WALTON CLARK, Ass't Gen'l Supt.

H. H. EDGERTON, Chem. and Eng'r.

DIRECTORS:

GEORGE PHILLER,

THOMAS DOLAN,

HENRY C. GIBSON,

WM. T. CARTER,

WILLIAM G. WARDEN,

SAML T. BODINE.

BUILDERS, LESSEES AND PURCHASERS OF

✻ GAS WORKS. ✻

ROOTS' GAS AND BYE-PASS VALVES.



GAS VALVE

Quick Acting,
Simple,
Efficient, Durable.

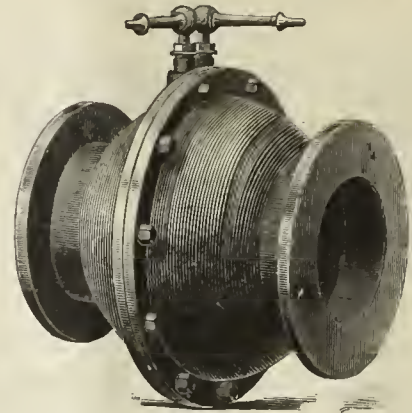

BYE-PASS VALVE.

Automatic Action,
Reliable
Simple, Durable.

Thousands now in use and giving perfect satisfaction. Write for Catalogue and Prices.

ROOTS' NEW GAS EXHAUSTER.

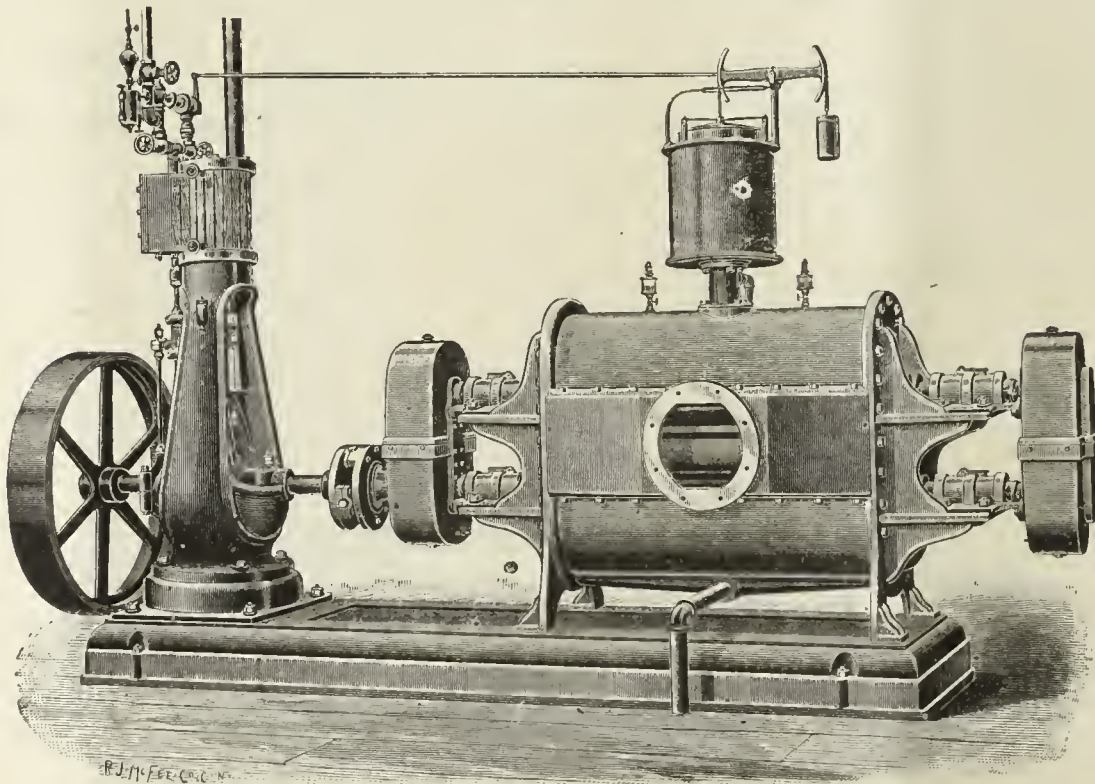

UNSURPASSED FOR

Neatness of Design, Durability, Simplicity, Efficiency, and Economy of Power.

THE ONLY EXHAUSTER MADE WHERE

The Parts Needing Attention are External, and Easily Accessible.

Send for Descriptive Catalogue and Price List.

THE P. H. & F. M. ROOTS CO., Patentees and Manufacturers, **CONNERSVILLE, IND.**

S. S. TOWNSEND, Gen. Agt., 22 Cortlandt St., N. Y.

COOKE & CO., Selling Agts., 22 Cortlandt St., N. Y.

CONNELLY & CO.,

SOLE MANUFACTURERS OF THEIR PATENTED SPECIALTIES.

"IRON SPONGE." Saves money, saves labor, and is the most efficient purifying agent ever offered as a substitute for lime. Now used *in every State in the Union*, and purifying daily over *thirty-five million cubic feet*. Should be used in every gas works. Its own saving will pay for it many times over.

AUTOMATIC GOVERNOR. Has been on the market but *three years*, and in that time has been introduced *more generally* than any invention ever designed for use in gas works. Over *two hundred* of them now in use. Sensitive; reliable; perfectly automatic; reduces leakage; satisfies consumers, and gives great relief to the Manager. No gas works is *complete* without one of these machines.

STEAM JET EXHAUSTER. Designed particularly for small works. Combines Exhaust Tube, Steam Governor Gas Compensator, and Bye-Pass Valves in the most compact form possible; occupies but little space; uses very little steam; operated by ordinary workmen; saves formation of carbon in retorts; increases yield 10 to 15 per cent. Specially adapted for *mixing air* with oil gas. *No works* too small to use them profitably.

Prices given on all our specialties *delivered at any point in the United States*. Correspondence solicited.

CONNELLY & CO., No. 111 Broadway, New York City.

WILBRAHAM GAS EXHAUSTER & ENGINE COMBINED.

WILBRAHAM BROS.,
PHILADELPHIA, PA.

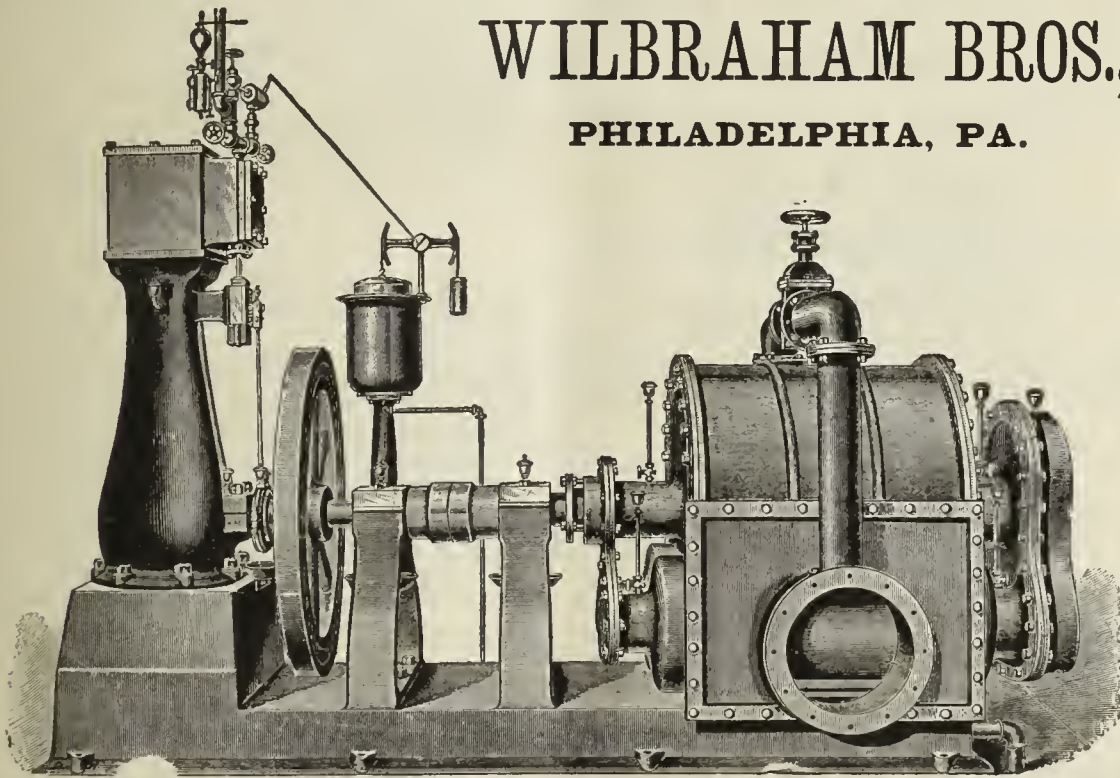

JARVIS ENGINEERING CO.,

61 Oliver St., Boston, Mass.

CONTRACTORS FOR ERECTING

COMPLETE STEAM OUTFITS FOR ELECTRIC LIGHTING STATIONS.

Steel Boilers set with Jarvis Pat. Boiler Setting

To burn **COKE SCREENINGS** for Fuel.

ARMINGTON & SIMS CO. ENGINES,

Belting direct to Dynamos, without using Shafting.

SEND FOR CIRCULARS.

REFERENCES.—Charlestown Gas & Electric Light Co., Charlestown, Mass.; Schenectady Gas & Electric Light Co., Schenectady N. Y.; Brookline Gas Co., Brookline, Mass.

Practical Electric Lighting

By A. BROMLEY HOLMES, A.M.I.C.E.

With 87 Illustrations. Third Edition. Price, \$1.00.

Electric Light Primer.

By CHARLES L. LEVEY.

A simple and comprehensive Digest of all the most important facts connected with the running of the Dynamo and Electric Lights, with Precautions for Safety, etc.

Price, 50 cents.

A. M. CALLENDER & CO., 42 Pine St., N. Y.

Gasholder Tanks & Gas Works Masonry Complete.

PLANS PREPARED AND ESTIMATES FURNISHED AT SHORT NOTICE.

J. P. WHITTIER, - - 499 Wythe Av., Brooklyn, N. Y.

1889 DIRECTORY 1889

OF THE GAS LIGHT COMPANIES of the UNITED STATES & CANADA

Price, \$8.00.

A. M. CALLENDER & CO., No. 42 Pine Street, N. Y. City.



CHAPMAN VALVE MANUFACTURING CO.,

MANUFACTURERS OF

Valves and Gates for Gas, Ammonia, Water, Etc.

Also, Gate Fire Hydrants With and Without Independent Nozzle Valve. All Work Guaranteed.

WORKS & GEN'L OFFICE:
Indian Orchard, Mass.

TREASURER'S OFFICE:
72 Kilby & 112 Milk Sts, Boston, Mass.

LUDLOW VALVE MFG. CO.



OFFICE AND WORKS,

938 to 954 River Street and 67 to 83 Vail Av.,
TROY, N. Y.

GEO. SHEPARD PAGE,

No. 69 Wall Street, N. Y. City.

REPRESENTING

THE BOWER GAS LAMP.

C. & W. Walker's Carbonic Acid & Tar Extracting Washer

B. DONKIN & CO.'S PAT. IMP. GAS VALVE.

Young & Beilby's Patents. Henry Aitkin's Patents.

R. P. SPICE, London, Eng. HENRY SIMON, Manchester, Eng.

MILLS' REVERSIBLE LIME TRAY,

AND

WOODWORK

Of Every Description

NEEDED BY GAS WORKS.

SEND FOR CIRCULAR AND PRICE LIST TO

BARTLETT, HAYWARD & CO.,

Pratt and Scott Streets, Baltimore, Md.



Hydraulic Main Dip Regulators, also
Check Valves, Foot Valves, Yard-
wash and Fire Hydrants.
Send for Circulars.

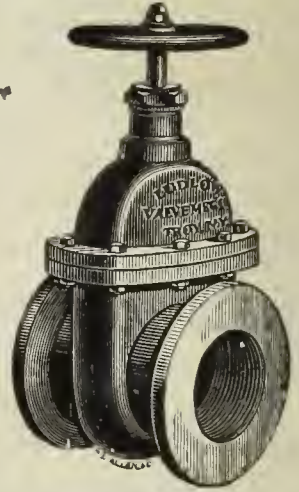

Valves.—Double and Single Gate, 1/2 in. to
48 in., outside and inside Screws. Indica-
tor, etc., for Gas, Water, Steam, and Oil.
Send for Circulars.

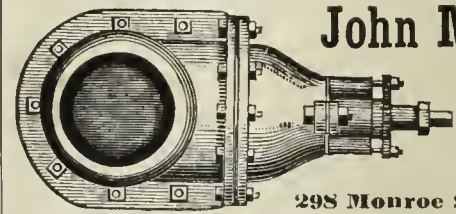

John McLean

Man'facturer

**GAS
VALVES.**

298 Monroe Street, N. Y.

VAN DUZEN GAS & GASOLINE ENGINE

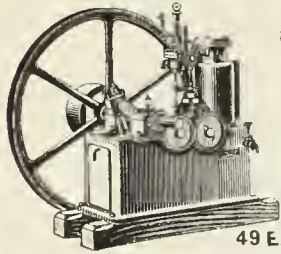

OPERATED with COAL
and OTHER MANUFAC-
TURED GASES AND
GASOLINE.

**RELIABLE AND
ECONOMICAL.**

Fully Warranted

VAN DUZEN

Gas & Gasoline Engine Co.
49 E. 2d St., Cincinnati, O.

A. MacKinnon Machine Co., Agts., 22 Warren St., N.Y.

The Management of Small Gas Works.

BY C. J. R. HUMPHREYS.

Price, \$1.

Orders to be sent to **A. M. CALLENDER & CO.,**

42 PINE STREET, NEW YORK.

SPECIAL TRAYS FOR IRON SPONGE OR OXIDE OF IRON.
CHURCH'S TRAYS A SPECIALTY.
REVERSIBLE—STRONGEST—MOST DURABLE—MOST EASILY REPAIRED.

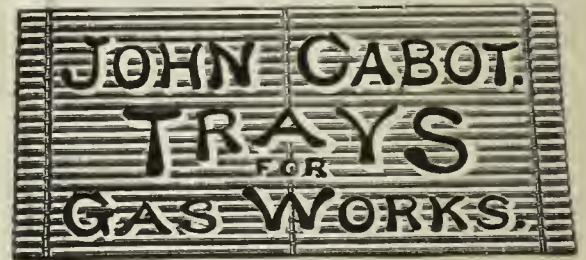

306-310 ELEVENTH AVENUE, NEW YORK.

WE ALSO MAKE THE CHEAPEST AND STRONGEST
REVERSIBLE BOLTED TRAYS IN THE MARKET.

THE CLERK GAS ENGINE CO.,

Main Office, 1012, 1014, 1016, 1018 Filbert St., Philadelphia, Pa.

WM. W. GOODWIN, Prest.

E. STEIN, Sec.

S. LEWIS JONES, Asst. Sec.

A. J. DOTY, Supt.

The utility and convenience of the Gas Engine being no longer an open question, it only remains now for intending purchasers to select the BEST. We claim for the CLERK GAS ENGINE that it is equal to any other manufactured as regards steadiness in running, simplicity, and ease of keeping in repair, and that it gives the greatest amount of power for the least money (both in first cost and expense of running) of any engine made. In support of this claim we refer to the test of the Gas Engines made under the direction of the American Institute of New York, in December, 1885, and heretofore published in these columns. These engines are especially adapted for continuous running under heavy loads, and we can refer to Engines which have run 22 hours a day for months at a time

Made in Sizes of 5 10 15 20. and 25 Horse Power. All Engines Guaranteed for One Year.

GAS STOVES.

GAS METERS.

GAS STOVES.

THE AMERICAN METER CO.,

MANUFACTURERS OF

GAS METERS, Station Meters,

METER PROVERS, PHOTOMETERS,
PRESSURE GAUGES OF ALL KINDS,



Standard 3 Diaphragm Dry Meter

AND



Standard 2 Diaphragm Dry Meter.

Apparatus for Testing the Quantity and Quality of Gases.

GAS STOVES FOR HEATING AND COOKING

Sole Agents in the United States for

Verity's Patent Gas Fires.

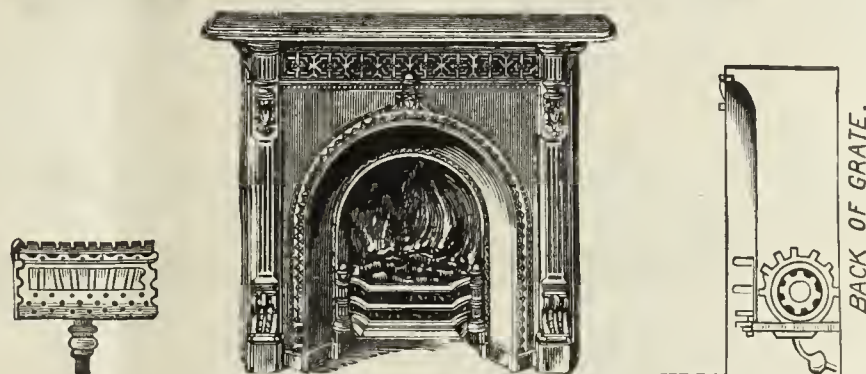

Circulars and Price Lists on Application.

MANUFACTORIES,

508 to 514 West Twenty-second St., N. Y.

Arch and Twenty-second St., Phila.

Nos. 244 & 246 North Wells Street, Chicago, Ill.

AGENCIES,

No. 177 Elm Street, Cincinnati, Ohio.

No. 222 Sutter Street, San Francisco, Cal.

No. 810 North Second Street, St. Louis, Mo.

GAS STOVE SHOW ROOMS, No 242 Sixth Avenue, New York City.

RETORTS AND FIRE BRICK.

RETORTS AND FIRE BRICK.

RETORTS AND FIRE BRICK.

J. H. GAUTIER & CO.,

CORNER OF
GREENE AND ESSEX STREETS,
JERSEY CITY, N. J.

MANUFACTURERS OF

**Clay Gas Retorts,
Gas House Tiles,
Fire Bricks, Etc. Etc.**

Ground Clay, Fire Brick and
Fire Sand in Barrels,

J. H. GAUTIER. C. E. GREGORY. C. E. GAUTIER.

BROOKLYN

Clay Retort & Fire Brick Works,
(EDWARD D. WHITE & CO.)

Manufacturers of Clay Retorts, Fire Brick,
Gas House and other Tile.

VAN DYKE, ELIZABETH, RICHARDS & PARTITION STS.
Office, 88 Van Dyke St., Brooklyn, N. Y.

LACLEDE FIRE BRICK MFG. CO.,

MANUFACTURERS OF

Fire Brick, Gas Retorts,

AND

ST. LOUIS STANDARD SEWER PIPE.

Blast Furnace and Cupola Linings, every description of Fire
Clay Material, Fire Clay Flue Linings, Chimney Tops
Dry Milled and Crude Fire Clays, etc.

OFFICE AND DEPOT

901, 903, and 905 Pine Street,
ST. LOUIS, MO.

ESTABLISHED IN 1845.

B. KREISCHER & SONS,

OFFICE FOOT OF HOUSTON ST., E. R., N. Y.

Gas Retorts,**TILES, FIRE BRICK.**

AND EVERYTHING IN THE FIRE CLAY LINE.

**MANHATTAN
FIRE BRICK & ENAMELLED CLAY
RETORT WORKS****ADAM WEBER.****CLAY GAS RETORTS****AND RETORT SETTINGS****FIRE BRICKS, TILES, ETC.,**

Office and Works, 15th Street and Avenue C., N. Y.



Works,
LOCKPORT STATION, PA.

—ESTABLISHED 1864.—

JAMES GARDNER, JR.,

Office, Rooms 19 & 20, Lewis Block,
PITTSBURGH, PA., P. O. Box 373.

Successor to WILLIAM GARDNER & SON.

Fire Clay Goods for Gas Works.

H. A. NORTON, No. 4 CENTRAL STREET, BOSTON, MASS., Agent for the New England States.

GEO. C. HICKS,
Prest.**CHICAGO**CHAS. A. REED,
Sec. & Treas.**Retort and Fire Brick Co.,**

MANUFACTURERS OF

Fire Clay Goods of all Kinds,

AND BEST QUALITY ONLY.

Regenerative Furnaces & Water Gas Goods.

45th St., Clark to La Salle, Chicago.

GEROULD'S IMPROVED RETORT CEMENT.

A Cement for patching retorts, putting on mouthpieces, and
making up all bench-work joints. This Cement is mixed ready
or use. Economic and thorough in its work. Fully warranted
o stick. For recommendations and price list address

C. L. GEROULD & CO.,

5 & 7 Skillman St., Brooklyn, N. Y.

Western Agent. H. T. GEROULD, Mendota, Ill.

**Parker-Russell
Mining and Mfg. Co.,**

CITY OFFICE,

Mermod-Jaccard Bldg., Rooms 307 & 308,
Broadway & Locust St., St. Louis, Mo.

PROPRIETORS OF THE

OAKHILL GAS RETORT & FIRE BRICK W'KS

Our immense establishment is now employed almost entirely in
the manufacture of

Materials for Gas Companies

We have studied and perfected three important points. Our re-
torts are made to stand changes of temperature, the strongest
heats of the furnace, and the abrasion of feeding and emptying.
We have the exclusive Agency for the West of the celebrated

**Kloenne-Bredel Full Depth and
Semi-Recuperator Benches,**

And also furnish and build

Our Own Styles Semi-Recuperator Furnaces
for the use of Coal or Coke as fuel.

THOS. SMITH, Prest.

AUGUST LAMBLA, Vice-Prest. & Supt.

BALTIMORE**RETORT & FIRE BRICK CO.**

MANUFACTORY AT

LOCUST POINT, BALTIMORE, MD.

Clay Retorts, Blocks & Tiles,**FIRE BRICK, FIRE CLAY,****AND FIRE CEMENT.**

Red and Buff Ornamental Tiles and Chim-
ney Tops. Drain and Sewer Pipe (from
2 to 30 inches). Baker Oven Tiles
12x12x2 and 10x10x2.

WALDO BROS., 88 WATER ST., BOSTON, MASS

Sole Agents the New England States.

Boston Fire Brick Works Manufacturers of **Gas Retorts and Settings**

Under the Personal Supervision of MR. GEO. C. HICKS late of Chicago.

Fire Clay Goods of all kinds. Akron Sewer Pipe, Lime, Cement, etc. Agts. for the Arc Gas Lamp & Governing Gas Burners.

Send for Circulars and Prices to

FISKE, COLEMAN & CO., Managers, No. 62 Congress Street, Boston, Mass.

HENRY MAURER & SON,
 (ESTABLISHED 1856.)
EXCELSIOR FIRE BRICK & CLAY
RETORT WORKS
 WORKS, Perth Amboy, N. J.
 OFFICE, 418 to 422 East 23d St., N. Y.
Clay Gas Retorts,
BENCH SETTINGS,
 Fire Brick, Tiles, Etc.

FLEMMING'S
Generator-Gas Furnace

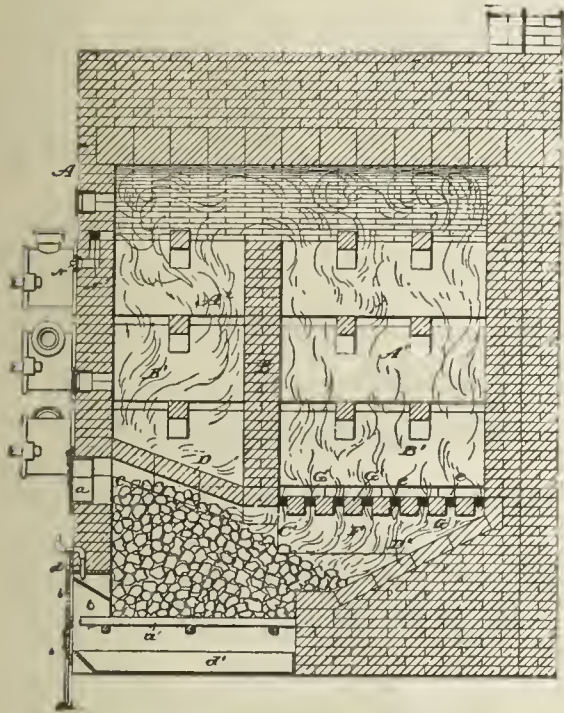

Materials furnished and Benches erected by

J. H. GAUTIER & CO., - Jersey City, N. J.
 Address as above, or D. D. FLEMMING, Jersey City, N. J.

FRED. BREDEL,
 CONTRACTOR FOR THE COMPLETE
Erection and Equipment of Gas Works.
 SOLE PROPRIETOR OF THE
KLOENNE PATENTS
 FOR NORTH AMERICA.
REGENERATIVE FURNACES.

(900 Retorts are now fired in America by the Kloenne-Bredel System.)

SELF-SEALING MOUTHPIECES.

(Over 800 Now in Use.)

Standard Condensers. Washer-Scrubbers.

TAR WASHERS FOR WATER GAS PLANTS.

(In use in the works of the Chicago Gas Lt. Co.)

GASHOLDERS.

Bredel's Automatic Gas Governor.

Refers, by permission, to Mr. Eugene Vanderpool, Newark, N. J.; Mr E. G. Cowdery, Milwaukee, Wis.; and Mr. Theo. Forstall, Chicago, Ills. For further infomation, address

FRED. BREDEL,
No. 208 East Seventeenth Street, N. Y. City.

<p>COMPOUND Condensing or Non-Condensing. 16 SIZES, 5 to 500 H. P. Not yet equaled by any form of Engine for HIGH FUEL DUTY AND SIMPLICITY.</p> <p>STANDARD 13 Sizes in Stock. 5 to 250 H. P. 3000 in use in all parts of the Civilized World.</p> <p>JUNIOR 6 Sizes in Stock, 5 to 50 H. P. An Automatic Engine cheaper than a Slide Valve. WELL BUILT. ECONOMICAL. RELIABLE. Over 300 Sold the First Year.</p> <p>All the above built strictly to Gauge with INTERCHANGEABLE PARTS. REPAIRS CARRIED IN STOCK. SEND FOR ILLUSTRATED CATALOGUES.</p>	<p>WESTINGHOUSE ENGINES The Westinghouse Machine Co. PITTSBURGH, PA. U.S.A.</p>	<p>SELLING DEPARTMENT IN THE UNITED STATES.</p> <table border="0"> <tr> <td>New York,</td> <td>47 Cortlandt St.</td> <td rowspan="4">} Westinghouse, Church, Kerr & Co.</td> </tr> <tr> <td>Boston,</td> <td>Hathaway Building,</td> </tr> <tr> <td>Pittsburgh,</td> <td>Westinghouse Build'g,</td> </tr> <tr> <td>Chicago,</td> <td>156, 158 Lake St.</td> </tr> <tr> <td>Philadelphia,</td> <td>608 Chestnut St.</td> <td>M. R. Muckle, Jr. & Co.</td> </tr> </table> <p>ST. LOUIS, 511 NORTH FOURTH ST., Westinghouse, Church, Kerr & Co.</p> <table border="0"> <tr> <td>Salt Lake City,</td> <td>259 S. Main St.</td> <td rowspan="2">} Utah & Montana Machinery Co.</td> </tr> <tr> <td>Butte, Mont.</td> <td>1. Granite St.</td> </tr> <tr> <td>San Francisco,</td> <td>21, 23 Fremont Street,</td> <td rowspan="2">} Parke & Lacy Co.</td> </tr> <tr> <td>Portland, Or.</td> <td>33, 35 N. Front St.</td> </tr> <tr> <td>Charlotte, N. C.</td> <td>36 College St.</td> <td rowspan="2">} The D. A. Tompkins Co.</td> </tr> <tr> <td>Atlanta, Ga.</td> <td>45 S. Prior St.</td> </tr> <tr> <td>Dallas, Tex.</td> <td colspan="2">Keating Imp. & Machine Co.</td> </tr> <tr> <td>Chattanooga, Tenn.,</td> <td colspan="2">G. E. James & Co.</td> </tr> </table>	New York,	47 Cortlandt St.	} Westinghouse, Church, Kerr & Co.	Boston,	Hathaway Building,	Pittsburgh,	Westinghouse Build'g,	Chicago,	156, 158 Lake St.	Philadelphia,	608 Chestnut St.	M. R. Muckle, Jr. & Co.	Salt Lake City,	259 S. Main St.	} Utah & Montana Machinery Co.	Butte, Mont.	1. Granite St.	San Francisco,	21, 23 Fremont Street,	} Parke & Lacy Co.	Portland, Or.	33, 35 N. Front St.	Charlotte, N. C.	36 College St.	} The D. A. Tompkins Co.	Atlanta, Ga.	45 S. Prior St.	Dallas, Tex.	Keating Imp. & Machine Co.		Chattanooga, Tenn.,	G. E. James & Co.	
New York,	47 Cortlandt St.	} Westinghouse, Church, Kerr & Co.																																	
Boston,	Hathaway Building,																																		
Pittsburgh,	Westinghouse Build'g,																																		
Chicago,	156, 158 Lake St.																																		
Philadelphia,	608 Chestnut St.	M. R. Muckle, Jr. & Co.																																	
Salt Lake City,	259 S. Main St.	} Utah & Montana Machinery Co.																																	
Butte, Mont.	1. Granite St.																																		
San Francisco,	21, 23 Fremont Street,	} Parke & Lacy Co.																																	
Portland, Or.	33, 35 N. Front St.																																		
Charlotte, N. C.	36 College St.	} The D. A. Tompkins Co.																																	
Atlanta, Ga.	45 S. Prior St.																																		
Dallas, Tex.	Keating Imp. & Machine Co.																																		
Chattanooga, Tenn.,	G. E. James & Co.																																		

Newbigging's Handbook for Gas Engineers and Managers.

The present (the fifth) edition marks an important advance on those that have gone before. Considerable additions have been made to the text, and much of it has been re-written and otherwise improved. It extends to 524 pages, and contains 193 illustrations. Price, Cloth, \$6.00.

A. M. CALLENDER & CO., - - - No. 42 Pine Street, N. Y. City.

GAS AND WATER PIPES.

GAS AND WATER PIPES.

ENGINEERS.

SAM'L R. SHIPLEY, Pres.
HENRY B. CHEW, Tre.

JAS. P. MICHELLON, Sec.
WM. SEXTON, Supt.

GLOUCESTER IRON WORKS,
GLOUCESTER CITY, N. J.



Cast Iron Gas & Water Pipes, Stop Valves, Fire Hydrants, Gasholders, &c.

Office, Rooms 61 and 63 Bullitt Building, 131 S. 4th St., Phila., Pa.

WARREN FOUNDRY AND MACHINE CO.,

Established 1856. Works at Phillipsburgh, N. J.

New York Office, 160 Broadway.

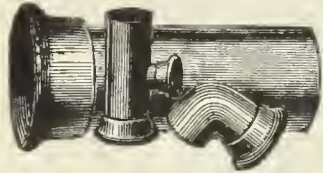

CAST IRON WATER AND GAS PIPE,

FROM TWO TO FORTY-EIGHT INCHES DIAMETER. ALSO, ALL SIZES OF

Flange Pipe for Sugar House and Mine Work. Branches, Bends, Retorts, etc., etc.

DENNIS LONG & COMPANY,

LOUISVILLE, KY.,



Manufacture Exclusively

CAST IRON GAS & WATER PIPE & SPECIAL CASTINGS
OF ALL SIZES.

King's Treatise on Coal Gas.

A standard text-book for the Engineers and Managers of Gas Works, and for all who are concerned or take an interest in the manufacture and distribution of Coal Gas, and in the utilization of the Secondary Products resulting therefrom; treating also of the Gas Engine, and of Gas Cooking and Heating Appliances.

In 3 Vols. Price per Vol., \$10. Sold either by Volume or in Sets.

A. M. CALLENDER & CO., 42 Pine St., N. Y.

P. D. WANNER, Chairman. A. H. MELLERT, Mangr. of Wks.
R. B. KINSEY, Secretary. F. A. KNOPP, Treasurer.

MELLERT FOUNDRY & MACHINE CO. Ltd.
and **READING FOUNDRY CO., Ltd.**
Reading, Pa.



Specials—Flange Pipe, Valves and Hydrants
Lamp Posts, Retorts, etc.

General Foundry and Machine Work.
JOHN FOX, Selling Agent. 160 Broadway, N. Y.

THE OHIO PIPE COMPANY,

MANUFACTURERS OF

Cast Iron Gas & Water Pipe,

BRANCH AND SPECIAL CASTINGS.

Gas-House Bench Castings, Hydraulics, Lamp Posts, Flange Pipe
and Specials, Architectural Castings, Building Columns,
Joists, Cellar Grates, Sash Weights, etc.

GENERAL FOUNDERS AND MACHINISTS.
Columbus, Ohio.

M. J. DRUMMOND,



SPECIAL CASTINGS AND LAMP POSTS.
Office, Corbin Building, 192 Broadway, N. Y.

EMAUS PIPE FOUNDRY.

DONALDSON IRON COMPANY. EMAUS, PA.



MANUFACTURERS OF

CAST IRON PIPE AND SPECIAL CASTINGS
FOR WATER AND GAS.

JOS. R. THOMAS,

No. 42 Pine Street, N. Y. City.

CONSULTING AND CONSTRUCTING
Gas Engineer and Contractor.

PLANS, SPECIFICATIONS, AND ESTIMATES
FURNISHED.

Contracts taken for all Appliances
required at a Gas Works,
Either for New Works or Extensions to Old Plants.

WM. MOONEY

(Successor to WM. FARMER)

No. 94 Liberty St., N. Y. City.

GAS ENGINEER AND CONTRACTOR FOR THE ERECTION
OF GAS WORKS, OR APPARATUS OF ANY
CAPACITY.

Plans and Specifications Furnished.

WM. GARDNER,
Gas Engineer,

Lewis Block, Room 20, Pittsburgh, Pa.

Those who intend to make alterations in existing gas plants, or who contemplate the erection of new works, will find it to their interest to open correspondence with the above. Plans made and estimates furnished.

ARTLETT, HAYWARD & CO.

Baltimore, Md.

Triple Double, & Single-Lift
GASHOLDERS.

Iron Holder Tanks.

ROOF FRAMES.

Cirders.

BEAMS.

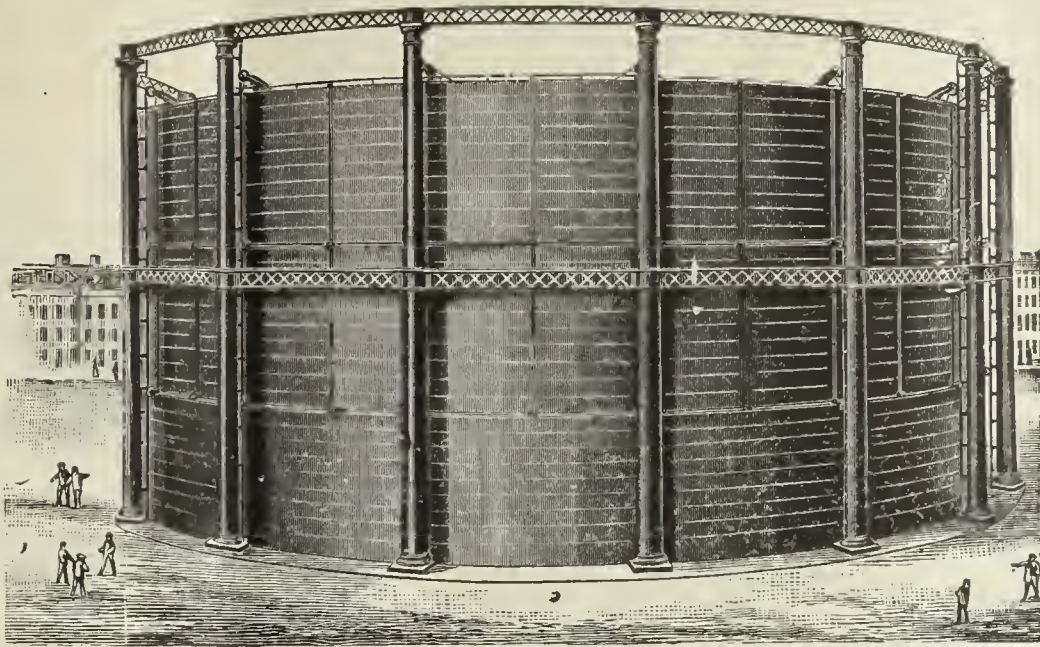

PURIFIERS.

CONDENSERS.

Scrubbers.

BENCH CASTINGS.

OIL STORAGE TANKS.

Boilers.

The Wilkinson Water Gas Process.

THIRTY-CANDLE, NON-CONDENSABLE, FIXED GAS. THE MOST SUCCESSFUL GAS PROCESS IN OPERATION.

Munich Regenerative Furnace, System Drs. Schilling & Bunte.

HAZELTON BOILERS.

Gas Works Designed and Constructed.

Pascal Iron Works. ESTABLISHED 1821. Delaware Iron Works.

MORRIS, TASKER & CO.,

INCORPORATED.

OFFICE, 224 SOUTH THIRD STREET, - - PHILADELPHIA, PA.

CONTRACTORS, BUILDERS, AND MANUFACTURERS OF

Gas, Water & Sugar Works

Bench Castings.

Condensers.

Scrubbers.

Purifiers.

Hyd. Carriages.

Iron Floors,

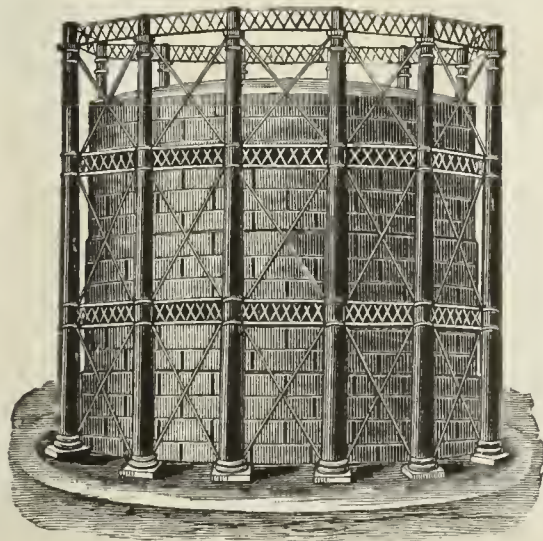

Iron Roofs.

Street Stops,

Valves, etc.

Stand-Pipes.

Water & Oil

Tanks, all Sizes.

Single, Double, and Triple-Lift Gas Holders.

SELF-SEALING RETORT LIDS. STAMPED STEEL RETORT LIDS.

Locomotive Water Columns, Filters, etc. Boiler Tubes, Wrought Iron Pipe & Fittings

Plans, Specifications and Estimates for all kinds of Machinery furnished on application.

Foundries & Works,
MILLVILLE, FLORENCE,
and CAMDEN, N. J.

R. D. WOOD & CO.,

Engineers,
Iron Founders,
and
Machinists.

400 Chestnut St., PHILADELPHIA, PA.

MANUFACTURERS OF

CAST IRON PIPE,

Gas Holders,

SINGLE, DOUBLE, AND TRIPLE LIFTS, WITH
OR WITHOUT WROUGHT IRON
OR STEEL TANKS.

PURIFIERS, CONDENSERS.

Scrubbers.

BENCH WORK.

Iron Floors and Roofs, Plate Girders.

Heavy Loam Castings.

HYDRAULIC WORK.

Lamp Posts, Valves, Etc.

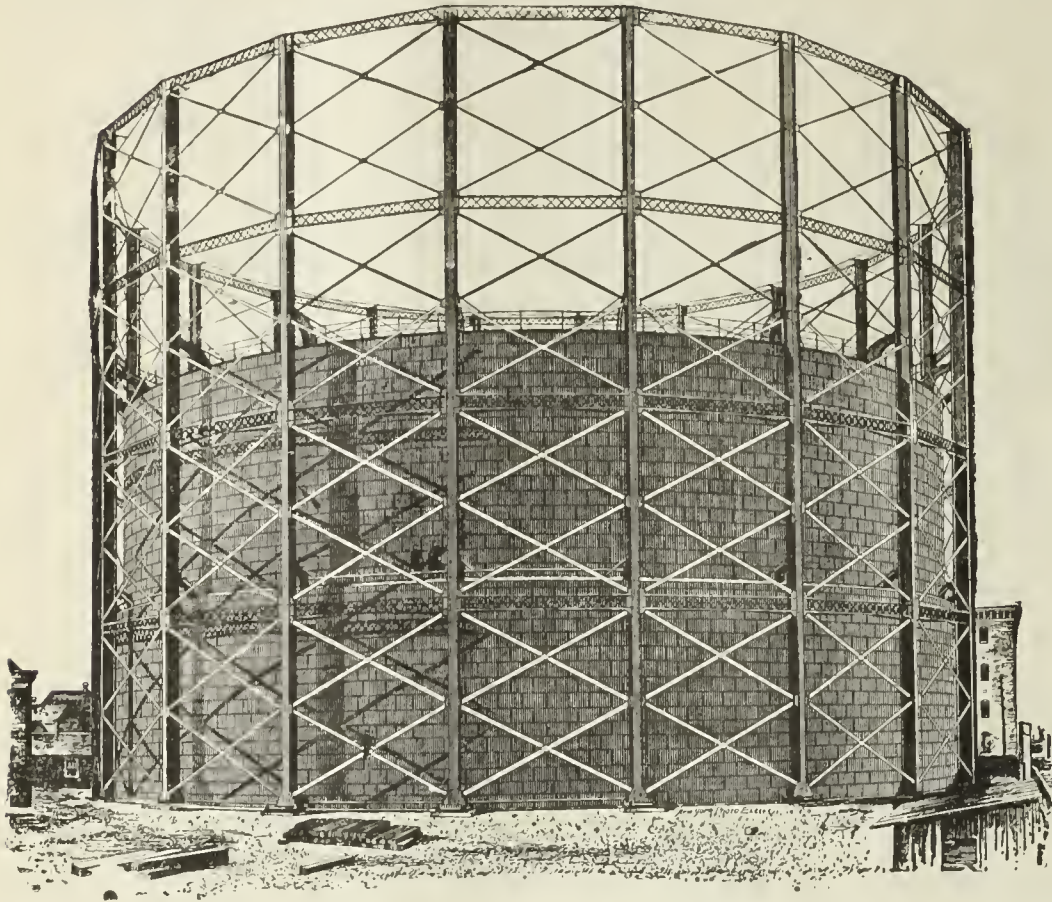

SMITH & SAYRE MFG. COMPANY,

G. G. PORTER, Prest.

245 Broadway, N. Y.

CHAS. W. ISBELL, Sec'y.

Machinery & Apparatus for Gas Works

Drawings, Plans, and Estimates Furnished for the Improvement, Extension, or Alteration of Gas Works, or for the Construction of New Works.

Mackenzie's Patent Rotary and Steam Jet Gas Exhausters, Governors, Compensators, Condensers, Washers, Scrubbers. Isbell's Patent Automatic Street Pressure Governor, Gas and Water Valves, Hydraulic Main Dip Regulator, Bench Castings, etc. Purifying Pipes and "Standard" Scrubbers. Isbell's Patent Self-Sealing Retort Doors.

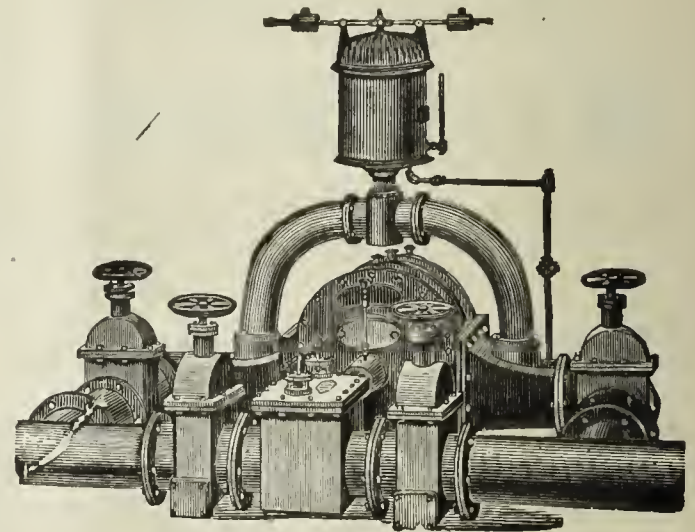

THE BRENNER SELF-SEALING RETORT DOOR.

Simple, Strong, and Durable.

CLOSES ABSOLUTELY TIGHT & IS LOCKED BY A CAM LEVER. ALL NECESSARY ADJUSTMENT FOR WEAR PROVIDED.

BUILT BY

SMITH & SAYRE MFG. CO.,

No. 245 Broadway, - - - New York City.

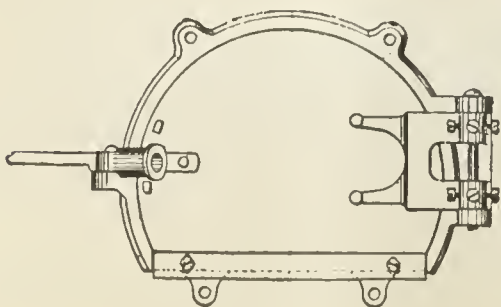

Brenner Self-Sealing Retort Door.

WILLIAM B. LUNDIE, Superintendent of the 42d Street Station of the Consolidated Gas Company, of New York, writes, under date of Jan. 4, 1889:

"We have 320 Brenner Self-Sealing Lids in use at this Station, built by the Smith & Sayre Mfg. Co. They require very little attention, and are the best of the kind that I have seen, giving entire satisfaction."

GAS WORKS APPARATUS AND CONSTRUCTION.

GAS WORKS APPARATUS AND CONSTRUCTION.

JAMES R. FLOYD & SONS,

(SUCCESSORS TO HERRING & FLOYD)

Oregon Iron Works,

W. 20th & 21st. Sts., bet. 10th & 11th Avs.,

NEW YORK CITY.

Engineers and Contractors

FOR THE

CONSTRUCTION OF GAS WORKS.

MANUFACTURERS OF

All Kinds of Castings and General Ironwork

FOR

GAS APPARATUS.

Bench Castings, Regenerative and Half Regenerative Furnace Castings.

Condensers, Scrubbers, Purifiers, Street Drips and Connections,

Valves,

Hydraulic Hoisting Purifier Carriage, Self-Sealing Retort Lids, Improved Valve Stand and Indicator, Seller's Cement.

Plans, Specifications, and Estimates furnished for Construction of New or Alteration of Old Works.

CONTINENTAL IRON WORKS.

THOS. F. ROWLAND, Prest.

WARREN E. HILL and CHAS. H. CORBETT, V-Prests.

THOS. F. ROWLAND, JR., Sec. & Tr

P. O. Station G., BROOKLYN, N. Y.

ENGINEERS AND MANUFACTURERS OF

Gas Holders

CONDENSERS, SCRUBBERS, VALVES,

PURIFIERS, SELF-SEALING RETORT LIDS.

Hydraulic Mairs,

And all other articles connected with the manufacture and distribution of Gas.

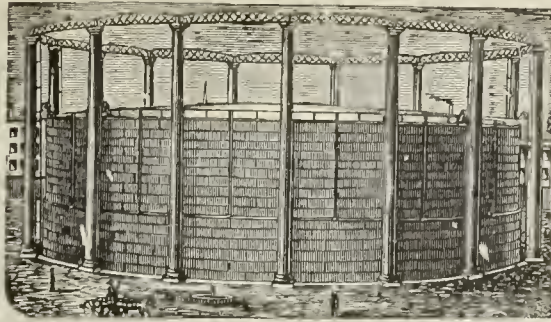

H. RANSHAW, Prest. & Mangr.

WM. STACEY, Vice-Prest.

T. H. BIRCH, Asst. Mangr.

R. J. TARVIN, Sec. & Treas.

STACEY MFG. CO.,

MANUFACTURERS OF

Single and Telescopic Gasholders,

IRON ROOFS, BRIDGES, LAMP POSTS,

Water and Oil Tanks, Coal Elevator Cars,

COKE CRUSHERS, BENCH CASTINGS,

And all kinds of Wrought and Cast Iron Work used in the erection of Coal and Oil Gas Works Rolling Mill Machinery and Heavy Castings a Specialty.

Foundry:

33, 35, 37 & 39 Mill Street.

Wrought Iron Works:

16, 18, 20, 22, 24 & 26 Ramsey Street:

Cincinnati, Ohio.

Bouton Foundry Co.,

FOUNDERS AND MACHINISTS,

CHICAGO, ILL.

Gas Works Apparatus,

PURIFIERS, CONDENSERS,

Bench Work

SPECIALS, LAMP POSTS,

SCRUBBERS,

Iron Roofs and Floors.

Plans and Estimates furnished for new works or extensions of old works.

1842. **DEILY & FOWLER,** 1889.

Laurel Iron Works.

Address, No. 39 Laurel Street, Philadelphia, Pa.

BUILDERS OF

GASHOLDERS,

Single and Telescopic.

HOLDERS BUILT 1884 TO 1888, INCLUSIVE:

- | | | | | |
|----------------------------|-----------------------------|---------------------------|--------------------------|------------------------|
| Newport, R. I. | Long Island City, N. Y. | Port Chester, N. Y. | Malden, Mass. | West Chester, Pa. (2d) |
| Portland, Oregon. | Macou, Ga. | New Rochelle, N. Y. | Paducah, Ky. | Lancaster, Pa. (3d) |
| Allegheny, Pa. (3d.) | York, Pa. | Salem, N. J. (3d) | Norwich, Conn. | Fac ny, Pa. (two) |
| Atlanta, Ga. (2d.) | Chester, Pa. | Omaha, Neb. (2d) | Seattle, W. T. | Mount Vernon, N. Y. |
| N.Y. City (Central Gas Co) | Hazleton, Pa. (2d.) | Lynn, Mass. (2d) | San Diego, Cal. | Binghamton, N. Y. |
| Lynchburg, Va. (2d.) | State Island, N. Y. | Little Rock, Ark. | Northern Gas Lt. Co., of | Concord, N. H. |
| Saylesville, R. I. | Sangerties, N. Y. | Irrington, N. Y. | New York, N. Y. | Dover, Del. (2d) |
| Rondout, N. Y. | Clinton, Mass. (Lan. Mills) | South Boston, Mass. | Westerly, R. I. | Calais, Me. |
| Atlantic City, N. J. | Chattanooga, Tenn. | Rye, N. Y. (2) | Willimantic, Conn | New London, Conn. (2d) |
| Augusta, Ga. | Galveston, Texas. (3d.) | Woodstock, Ont. | Mont-lair, N. J. | West Chester, N. Y. |
| Waltham, Mass. (2) | Omaha, Neb. | Malden, Mass. | Attleboro, Mass. | Bav Shore, L. I. |
| Mahanoy City, Pa. | Fort Plain, N. Y. | Staten Island, N. Y. (2d) | Santa Cruz, Cal. | Washington, D. C. |
| New Castle, Pa. | Brunswick, Ga. | Woodstock, Ont. | Erie, Pa. (2d) | |

WM. HENRY WHITE,

No. 32 Pine Street, - - - New York City.

ENGINEER AND CONTRACTOR FOR THE

Erection and Extension of Gas, Water, and Electric Light Works.

SOLE REPRESENTATIVE OF THE

McILHENNY REGENERATOR FURNACE PATENTS

And the Martin Water Gas Process.

Edison Incandescent and American Arc Electric Light Plants Installed.

Correspondence with Gas Companies contemplating extending or improving their Plants respectfully invited. Plans and Estimates Furnished.

GAS COALS.

CANNEL COALS.

GAS ENRICHERS.

JAMES D. PERKINS. **PERKINS & CO.,** F. SEAVERNES.
 228 & 229 Produce Exchange, New York.
 Cable Address, "PERKINS, NEW YORK." Post Office Box 3695, New York.

GENERAL SALES AGENTS FOR

The Youghioghenny River Coal Company's
OCEAN MINE YOUGHIOGHENY GAS COAL.

HON. W. L. SCOTT, Prest. M. H. TAYLOR, Vice-Prest.

This Colliery is located at SCOTT HAVEN, PA., in the center of the Youghioghenny Gas Coal District, and produces the ONLY RELIABLE YOUGHIOGHENY COAL for gas purposes. (See Map on p. 87 of this JOURNAL, Feb. 16, '85.)

POINTS OF SHIPMENT,

Locust Point, BALTIMORE. Pier No. 62, PHILADELPHIA.

Also, SOLE AGENTS for the

BRECKENRIDGE CANNEL,
OF KENTUCKY.

Within the past two years we have delivered this Cannel to over ONE HUNDRED COMPANIES IN THIRTY-THREE DIFFERENT STATES, and it is now in use in some of the large Gas Works

On the Continent and in South America,

where it successfully competes with the Australian Shale. It is the ONLY AMERICAN GAS CANNEL of sufficiently high grade to warrant EXPORTATION TO EUROPE AND SOUTH AMERICA, and it is the only economical substitute for OIL OR NAPHTHA. ONE GROSS TON will produce

10,000 Cubic Feet of 75 Candle Gas,	} equal to {	750,000 Candle Feet of Gas, and 26 Bushels of merchantable Coke weighing 900 Pounds
or 12,500 " " 60 " "		
or 15,000 " " 50 " "		

This is the ONLY GAS CANNEL that will produce a REALLY MERCHANTABLE COKE. It can be delivered in parcels of one carload or more to any point in the United States or Canada. Cargo shipments of any size required can be made from NEW YORK, PHILADELPHIA, BALTIMORE, or NEWPORT NEWS. Samples will be sent and particulars of price, etc., forwarded upon application to above address.

JAMES & WILLIAM WOOD,
Gas and Cannel Coal Contractors,

No. 40 St. Enoch Sq., Glasgow. No. 2 Talbot Court, London.

Proprietors of the BATHVILLE COLLIERIES (which produce the celebrated BOGHEAD CANNEL), Shields, Shieldmuir, Drumpeller, and other Collieries. This Firm offer

STANDARD CANNELS,
 Unequaled as Gas Enrichers.

Also, WEST FAIRMONT GAS COAL, of W. Va.

Analyses, prices, and all further information furnished on application to

Agency for U. S., Room 70, Nos. 2 & 4 Stone St., N.Y. City.

The Standard Oil Company,

REFINERS OF

NAPHTHA AND GASOLINES.

ALSO MANUFACTURERS OF

A Special Grade of Naptha for
 Gas Companies

FOR ENRICHING COAL GAS.

Correspondence solicited.

No. 43 Euclid Avenue, Cleveland, Ohio.

To Gas Companies.

We make to order CAP BURNERS to burn any amount under a stated pressure. Send for samples.

Also, SERVICE CLEANERS, DRIP PUMPS, and STREET MAIN PROVING APPARATUS.

O. A. GEFRORER,

248 N 5th Street, Phila., Pa.

COKE CRUSHERS.

GAS COALS.

GAS COALS.

Newburgh Orrel Coal and Coke Co.

MINERS AND SHIPPERS OF

STEAM, SMITHING, AND GAS COALS,
Foundry and Crushed Coke.

Home Office, 33 S. Gay Street, Baltimore, Md.

J. HARRY LEE, President.

Shipping Wharves, Locust Point, Baltimore.

The Despard Gas Coal Co.,

MINERS AND SHIPPERS OF

DESPARD GAS COAL,

AND MANUFACTURERS OF

COKE.

MINES, Clarksburg, Harrison Co., W. Va.

WHARVES, Locust Point, Baltimore, Md.

OFFICE, 225 E. German St., " "

ROUSSEL & HICKS, } AGENTS. } BANGS & HORTON,
71 Broadway, N. Y. } 60 Congress St., Boston.

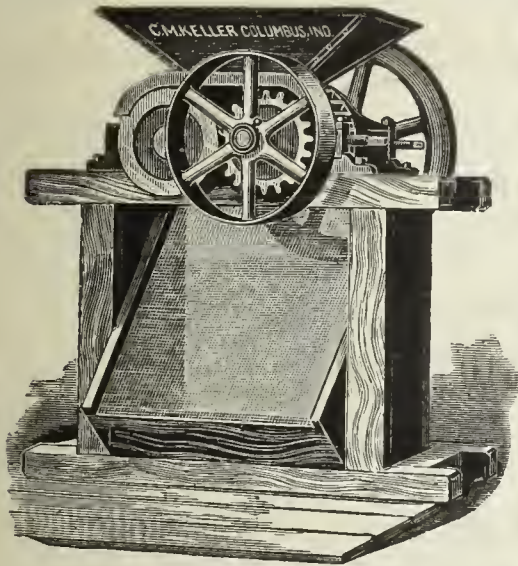

Keller's Adjustable Coke Crusher

SIMPLE, STRONG, AND DURABLE.

C. M. Keller, Sec. & Supt. Gas Lt. & Coke Co. Columbus, Ind

Correspondence Solicited.

King's Treatise on Coal Gas.

The most complete work on Coal Gas ever published.

Three Vols. Bound, \$30.

BOOKS.

DISTILLATION OF COAL TAR AND AMMONIACAL LIQUOR.

By GEORGE LUNGE. Price \$12.50.

A TREATISE ON THE COMPARATIVE COMMERCIAL VALUES OF GAS COALS AND CANNELS.

By DAVID A. GRAHAM. 8vo., Cloth. Price \$3.

Orders for these books may be sent to this office.

A. M. CALLENDER & CO.,

42 PINE ST., N. Y. CITY

THE
PENN GAS COAL CO.

OFFER THEIR

Coal, Carefully Screened & Prepared for Gas Purposes.

Their Property is located in the Youghiogheny Coal Basin, near Irwin and Penn Stations on the Pennsylvania Railroad, and on the Youghiogheny River.

Principal Office:

209 SOUTH THIRD STREET, PHILA., PA.

Points of Shipment:

Pennsylvania Railroad Piers; Greenwich Wharves, Delaware River; Pier No. 1 (Lower Side), South Amboy, N. J.

Chesapeake & Ohio Railway Coal Agency,

FOR THE SALE OF THE

Superior Kanawha Gas Coals, Cannelton Cannel, Also, SPLINT AND STEAM COALS,

From the Kanawha and New River Regions, on the line of the Chesapeake & Ohio R'way.

C. B. ORCUTT, General Agent, - - No. 1 Broadway (Room 217) New York City.

FRANCIS H. JACKSON, Prest. EDMUND H. McCULLOUGH, V.-Prest. CHAS. F. GODSHALL, Treas. H. C. ADAMS, Sec.

THE WESTMORELAND COAL CO.

Chartered 1854.

Mines situated on the Pennsylvania and the Baltimore and Ohio Railroads, in Westmoreland County, Penn.

POINTS OF SHIPMENT:

PHILADELPHIA, BALTIMORE, SOUTH AMBOY, N. J., WATKINS (SENECA LAKE), N. Y.

Since the commencement of operations by this Company its well-known Coal has been largely used by the Gas Companies of New England and the Middle States, and its character is established as having no superior in gas-giving qualities, and in freedom from sulphur and other impurities.

Principal Office, 224 South 3d St., Phila., Pa.

The American Gas Engineer and Superintendent's Handbook.

By WILLIAM MOONEY.

Consisting of Rules, Reference Tables, and Original Matter Pertaining to the Manufacture, Manipulation, and Distribution of Illuminating Gas.

350 Pages, Full Gilt Morocco.

\$3.00.

A. M. CALLENDER & CO., 42 Pine St., N. Y.

JOHN J. GRIFFIN & CO.,

Nos. 1513, 1515, 1517 & 1519 Race Street, PHILADELPHIA.
52 Dey St., NEW YORK. 75 N. Clinton St., (FRED. R. PERSONS, Mangr.) CHICAGO.

MANUFACTURERS OF

METERS FOR MEASURING GAS

IN ANY VOLUME.

Provers, Gauges, Registers, Etc., Etc.

EXPERIMENTAL APPARATUS FOR QUANTITATIVE AND QUALITATIVE ANALYSIS.

Careful and Prompt Attention paid to Repairing of all kinds of Meters and Apparatus.

Estimates Cheerfully Furnished.

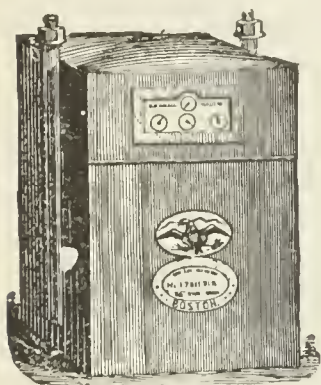

Dry Gas Meters.

With 40 years' experience and the best facilities for manufacturing, is enabled to furnish reliable work and answer orders promptly.

NATHANIEL TUFTS,

No. 153 Franklin Street, Boston, Mass.,

MANUFACTURER OF

DRY GAS METERS.

Station Meters of any Capacity.

Test and Experimental Meters, Pressure Registers, Pressure Gauges, Pressure and Vacuum Gauges.

METER PROVERS, PHOTOMETERS, STREET LANTERNS, ETC., ETC.

Patent Cluster Lanterns for Street Illumination.

HAROLD J. BELL.

BELL & JONES,

S. LEWIS JONES.

No. 12 North Ninth Street, Philadelphia, Pa. Works at Royersford, Pa.

MANUFACTURERS OF

GAS METERS, STATION AND EXPERIMENTAL METERS,

Meter Provers, Pressure Gauges, and All Other Gas Appliances in Our Line.

WE REPAIR ALL KINDS AND MAKES OF METERS, AND THE WORK GUARANTEED.

High Pressure Meters for Natural Gas, in Iron Cases, guaranteed to stand 300 lbs. Pressure.

Gas Cooking and Heating Stoves, Hot Plates, Cake Griddles, Waffle Bakers, Boiling Stoves, Laundry and Tailors' Iron Heaters. Hotel and Cafe Ranges a Specialty.

Correspondence Solicited.

Estimates Furnished.

A. HARRIS.

E. L. HARRIS.

J. A. HARRIS.

Established 1849.

HARRIS BROS. & CO.,

Twelfth and Brown Streets, Philadelphia.

Manufacturers of Wet and Dry Gas Meters,

STATION METERS, METER PROVERS,

EXPERIMENTAL METERS, SHOW OR GLAZED METERS,

Pressure and Vacuum Registers, Gauges, Photometers, Drip and Bell Pumps, Etc., Etc.

PROMPT ATTENTION GIVEN TO ALL ORDERS. METERS THOROUGHLY REPAIRED. ESTIMATES FURNISHED FOR STATION METERS OF ALL SIZES. CORRESPONDENCE SOLICITED.

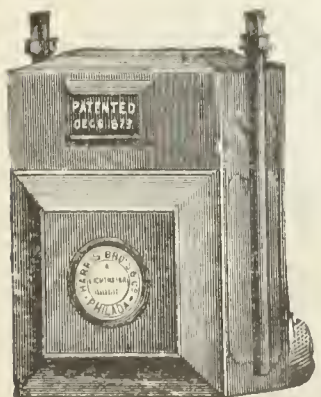

GAS METERS.

GAS METERS.

GAS METERS.

GEO. J. MCGOURKEY, Prest.

WM. H. MCFADDEN, Vice-Prest. (Phila.)

WM. N. MILSTED, Gen. Supt. and Treas. (New York).

WM. H. DOWN, Sec.

THE AMERICAN METER CO.

WET AND DRY GAS METERS.

PRESSURE REGISTERS.

METER PROVERS.

STATION METERS.

PRESSURE & VACUUM REGISTERS.

PORTABLE TEST METERS.

EXHAUSTER GOVERNORS.

PRESSURE & VACUUM GAUGES.

EXPERIMENTAL METERS.

DRY CENTER VALVES.

CRESSON GAS REGULATORS.

AMMONIA TEST METERS.

GOVERNORS FOR GAS WORKS.

MARSLAND WATER METERS.

BAR & JET PHOTOMETERS.

Manufactories:

512 West 22d St., N. Y.
Arch & 22d Sts., Phila.

GAS STOVES.

SUGG'S "STANDARD" ARGAND BURNERS,
SUGG'S ILLUMINATING POWER METER,
Wet Meters, with Lizar's "Invariable Measuring" Drum.

Agencies:

177 Elm Street, Cincinnati.
214 & 216 N. Wells Street, Chicago.
510 North Second Street, St. Louis.
222 Sutter Street, San Francisco.

HELME & McILHENNY,

(Established 1848.)

GAS METER MANUFACTURERS,

Nos. 1339 to 1349 Cherry Street, Philadelphia, Pa.,

WET AND DRY GAS METERS, STATION METERS, EXPERIMENTAL METERS, METER PROVERS,
Center Seals, Pressure Registers, Governors, Indicators, Photometers, and all other kinds of Apparatus for use in Gas Works.

FOULIS' PATENT STATION AND DISTRICT GOVERNORS.

REPAIRING DEPARTMENT.—We employ a special force of skilled workmen repairing meters of all makers.

THE GOODWIN GAS STOVE AND METER CO.,

Successors to W. W. GOODWIN & CO.

1012, 1014 and 1016 Filbert St., Phila., Pa.

142 Chambers St., New York City.

76 Dearborn, St., Chicago, Ills.

WALDO BROTHERS, Agents, 88 Water Streets, Boston, Mass.

MANUFACTURERS OF

DRY AND WET GAS METERS,

Station Meters (square, cylindrical, or in staves), Glazed Meters, King's and Sugg's Experimental Meters, Lamp Post Meters, etc., etc. Meter Provers (sizes 2, 5, and 10 feet), Pressure Gauges of all kinds, Pressure Registers, Pressure and Vacuum Registers, Pressure Indicators (sizes 4, 6, and 9 inch), King's Pressure and Vacuum Gauges, Dry and Wet Center Seals, Dry and Wet Governors, Exhauster Governors, Photometers of all descriptions. Letheby's Sulphur and Ammonia Test Apparatus complete. Also, Testing and Chemical Apparatus of all kinds, and of the most perfect description, for all purposes relating to Gas.

Manufacturers of the "SUN DIAL" GAS STOVES, for Cooking and Heating.

Goodwin's Improved Lowe's Jet Photometer.

Agents for Bray's Patent Gas Burners and Lanterns.

Special attention to Repairs of Meters and all Apparatus connected with the business. All work guaranteed first-class in every particular. Orders filled promptly.

G. B. EDWARDS, Manager, New York.

S. S. STRATTON, Manager, Chicago.

D. McDONALD & CO.,

GAS METER MANUFACTURERS.

(Established 1854.)

51 Lancaster St., Albany, N. Y.

34 & 36 West Monroe St., Chicago, Ill.

STATION METERS, EXPERIMENTAL METERS, METER PROVERS, PRESSURE & VACUUM REGISTERS, PRESSURE GAUGES, ETC

Also STAR GAS STOVES, RANGES, and HEATING STOVES.

We use only the very best materials, and employ the most skilled labor, and by our long experience (32 years) and personal supervision of every detail, we feel justified in assuring the public that our goods will give perfect satisfaction. Every Meter emanating from our establishment will bear the State Inspector's BADGE, and will be fully warranted by us. Our Annual and Calendar will be sent to Gas Companies upon application.

GAS STOVES.

GAS STOVES.

GAS STOVES.

THE GOODWIN GAS STOVE AND METER CO.,

1012-18 Filbert St., Phila., 142 Chambers St., N. Y., 76 Dearborn St., Chicago.

Agents, WALDO BROTHERS, 88 Water Street, Boston.

SOLE MANUFACTURERS OF THE

“SUN DIAL” GAS STOVES,

The Most Economical, Efficient, and Durable Gas Stove Made.

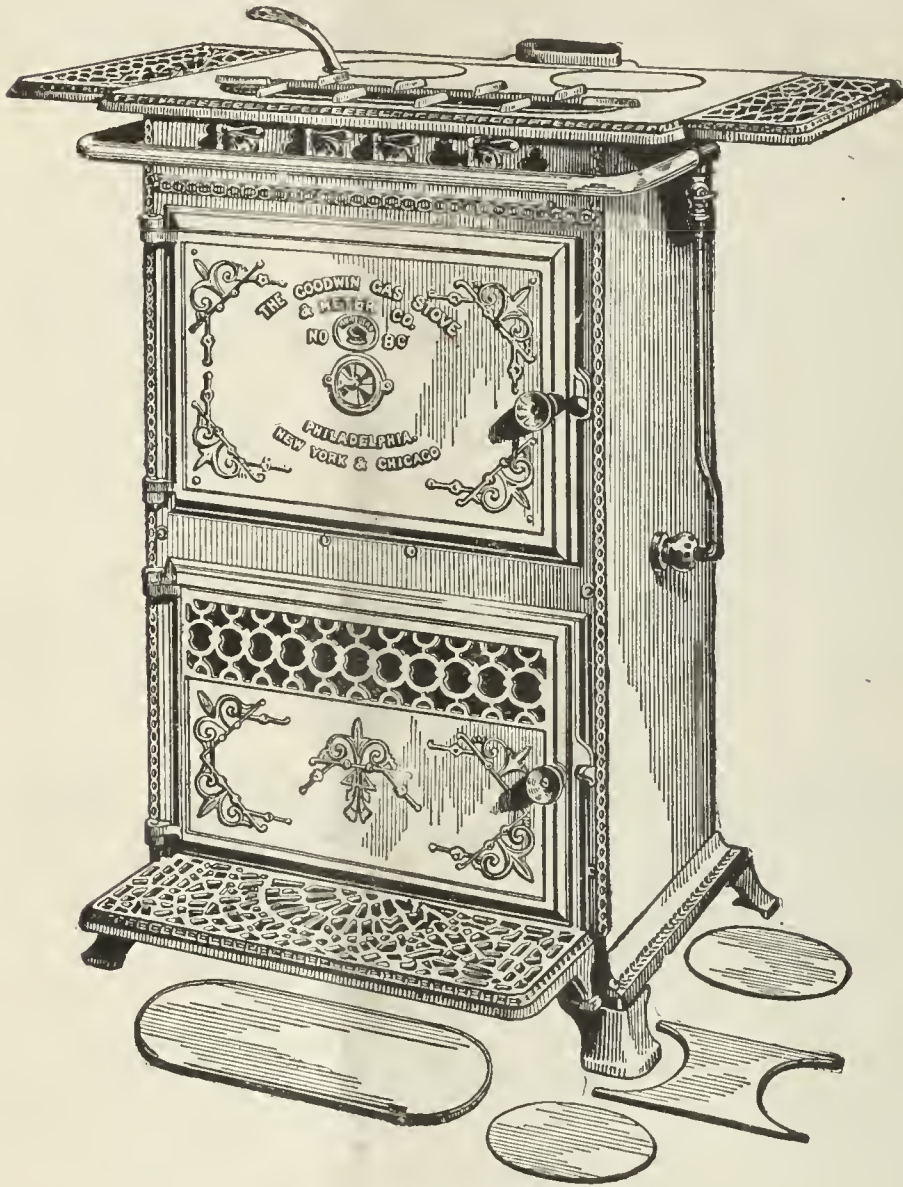

GAS COOKING STOVE, No. 8 C.

SIZE.

Stove.	Oven.	Roaster.	Top.	Length over Extension Shelves.
37 in. high. 20 in. wide.	12 in. high. 17 1/2 in. wide. 12 in. deep.	12 in. high. 18 in. wide. 13 in. deep.	24 in. long. 21 in. wide.	36 in.

This Stove has four burners on top, and double oven burner. Consumption of gas with all burners in use, 42 feet per hour, at 1 inch pressure. The top is made in sections, so that a greater variety of cooking utensils may be used. By lifting out the covers and crosspieces and putting in a suitable forked ring, which is sent with each stove, a wash boiler or other large utensil may be set over two burners. Our No. 87 GRIDDLE, also fits in the same position. The roasting oven is provided with a cast-iron door.

All Fittings are Nickel-Plated.

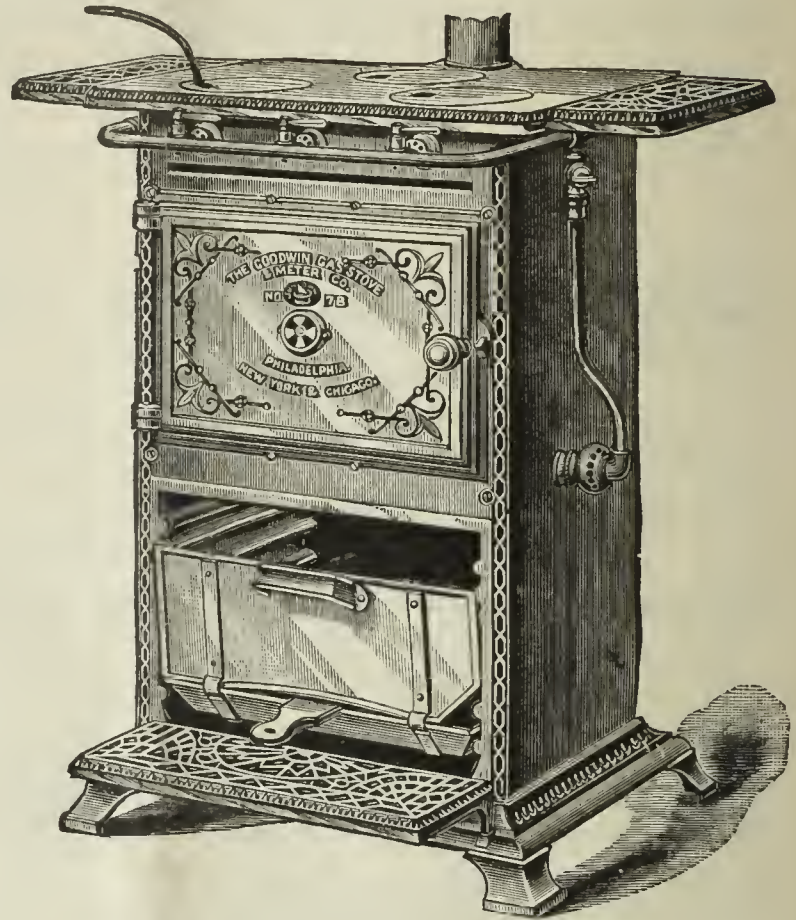

GAS COOKING STOVE, No. 7 B.

SIZE.

Stove.	Oven.	Roaster.	Top.	Length over Extension Shelves.
31 in. high. 17 in. wide.	9 1/2 in. high. 14 1/2 in. wide. 12 in. deep.	10 in. high. 15 in. wide. 13 in. deep.	21 in. long. 16 in. wide.	32 in.

This Stove has three boiling burners in the Top or Hot Plate, and one single oven burner.

This cut represents our New Style Cooking Stove. As will be seen, it has an ornamented cast-iron Base and Front, and extension shelves. The Oven Burner, which is atmospheric (unless otherwise ordered), is of an entirely new and improved pattern (patent). The ovens are of greater capacity than those of the old style. The Top, in conjunction with the Outlet Pipe, is designed to carry off all the products of combustion, if desired, but they are also supplied with a loose ring which converts it into an ordinary open top stove.

The consumption of this Stove is 35 cubic feet per hour at 1 inch pressure, with all Burners in use.

All Fittings are Nickel-Plated.

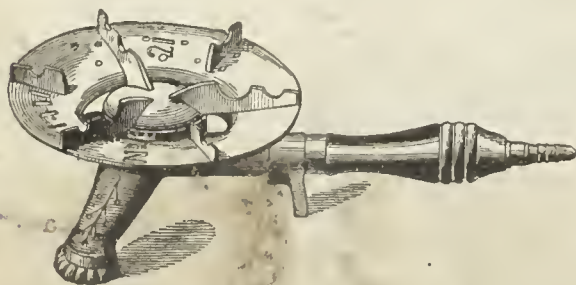

“RADIANT” BOILING STOVE, WITH REGENERATIVE BURNER.

Size, 6 1/2 inches diameter, 8 inches high. Consumption, 6 feet per hour at 1 in. pressure.



HOT PLATE, No. 111.

Size, 36 in. long, 12 in. wide, with three double burners, 6 taps. Consumption, with all burners in use, 36 cubic feet per hour, with 1 in. pressure. 1/2 in. supply pipe should be used where the pressure is 1 in. or over.

THE AMERICAN

GAS LIGHT JOURNAL

REDMAN & KENNY, N. Y.

PUBLISHING OFFICE No. 42 PINE STREET

DEVOTED TO THE INTERESTS OF ILLUMINATION, VENTILATION, WATER SUPPLY AND DISTRIBUTION, & GENERAL SCIENCE.

VOLUME LIII.—No. 14.
Whole No. 774.

NEW YORK, MONDAY, APRIL 7, 1890.

{ \$3 PER ANNUM,
IN ADVANCE.

A. M. CALLENDER & CO., Proprietors. C. E. SANDERSON, Manager.
JOS. R. THOMAS, C. E., Editor. T. J. CUNNINGHAM, Asst. Editor.

ENTERED AT THE POST OFFICE AT NEW YORK, N. Y.
AS SECOND CLASS MATTER.

Published on each Monday of the year, at No. 42 Pine Street, N. Y.

Terms of Subscription, Including Postage.—For the United States and Canada, \$3 per annum. European countries, \$4.50 (19 shillings—22½ francs). All payments to be made in advance. Single copies, 10 cents.

Remittances should be made either by post-office order, registered letter, or bank draft on New York, payable to the order of A. M. Callender & Co.

Collectors are invariably made directly from this office, for subscriptions, advertisements, etc. We have agents to solicit the same, but they are not authorized to receipt for money.

Correspondence.—Wishing to make this JOURNAL a gazette of intelligent discussion to those of our readers who may wish to gain or give information on the subjects to which its columns are devoted, correspondence is solicited for publication from all who make the study of those subjects a pleasure or a profession.

The American News Company, Nos. 39 and 41 Chambers street, New York, are agents for this JOURNAL. Newsdealers will send orders to them.

Books.—We will forward by express, at publisher's lowest rates, any book—scientific or otherwise—to any address in the United States or Canada. No books will be sent C. O. D.

CONTENTS.

An Asterisk (*) denotes an illustrated article.

EDITORIALS—

Briefly Told.....	461
The Rhode Island Gas Grab—Scant Justice—Hints from Alton, Ills.	
Practical Hints on Purification with Lime, by Mr. Frederic Egner.	462
The Market for Gas Securities	462
Sixth Annual Meeting, Ohio Gas Light Association.—Official Report —Revised by the Secretary—Continued from page 433.....	463
First Day, Morning Session: President's Address—Combination of Gas and Electric Lighting in Small Towns, by G. W. Bowers—Discussion. First Day, Afternoon Session: Graduated vs. Uniform Rates, by C. R. Faben, Jr.—Discussion—Municipal Control of Lighting, by H. Wilkiemeyer—Municipal Control of Gas Works, by M. A. Gemunder—Municipal Control of Gas and Electric Lighting Plants, by A. R. Foote—Joint Discussion—Sundry Matters—Ohio Street Lighting Statistics, by W. C. Hedges—Discussion. First Day, Evening Session—An Attack on the Question-Box—Advantages of a Combined Coal and Water Gas Plant, by Geo. A. Light—Discussion—An Invitation. Second Day, Morning Session: Our New Coal Gas Works, by G. A. Hyde, Sr.—Discussion.	
*Doubts vs. Dogmatism, by Mr. B. E. Chollar.....	485
The Influence of an Idea.....	485
Professor Wolcott Gibbs on Illuminating Gas.....	486

ITEMS OF INTEREST FROM VARIOUS LOCALITIES.....

Obituary Note—The Authorities of Providence, R. I., Aroused—Balance Sheet, Halifax, N. S.—The Situation at St. Louis, Mo.—Cheaper Gas for Stoughton, Mass.—No Experimental Electric Plant for Milwaukee—Annual Election, Middletown Conn.—Increasing the Montreal Company's Capital Stock—Philadelphia not to Engage in Electric Lighting—Accepted the Franchise—Messrs. R. D. Wood & Co. will Build the Holder—Mr. Vanderpool's European Trip—Text of the Wakefield Manufacturing Company's Ordinance—Annual Meeting, Terre Haute, Ind., Fuel Gas Company—New Gas Company—Figures as to Canada Gas Inspection—Report of the Senate Committee Hearing on the Wakefield Company's Proposition—A Suit—And another One of a Different Nature—Public Lighting, Greenfield, Mass.

BRIEFLY TOLD.

THE RHODE ISLAND GAS GRAB.—In our item columns will be found the latest news that we have respecting the attempt of certain capitalists to levy on the capital invested in the Gas Companies at Providence and Pawtucket, and interesting reading it will undoubtedly make. It is with satisfaction we note that the local authorities, who are ignored completely in the measure now under consideration in the Legislature, are disposed to resent not only the slight thus put upon them, but seem moved by the further impulse to protect the property that contributes so much to the comfort and convenience of the citizens. This is as it should be; and while we are not of the opinion that the Rhode Island Legislature or its chief executive officer—Governor Ladd—will authorize the grab in the consent of the State, we nevertheless believe that vigilance in watching the doings of the schemers will be necessary to defeat them. Another lesson that this attempt teaches is the absolute necessity that exists for the enactment of laws placing the gas business under the control of State Commissions.

SCANT JUSTICE.—In 1886 the authorities of Toronto entered into a public lighting agreement with the Consumers Gas Company, of that city, under which the latter was authorized to carry out an improved system of street lighting by gas, at a certain figure, the contract to last for 5 years, or until Jan. 1, 1891. In order to fully carry out the compact the Gas Company invested large amounts of money in lanterns and burners—the Lambeth type was most largely favored—and the expenditure on that account was supplemented by an investment of something over \$100,000 in new mains, which were put down in streets that were ordered lighted by the authorities, but in which the Company had not theretofore distributed gas. The service was fully up to the contract, but meanwhile the authorities became enamored of electric light, and taking advantage of a strained and peculiar construction of a clause in the contract with the Gas Company, it was not long before the latter was ordered to make wholesale discontinuance of its public gas lamps and lighting. So great had this drain become that Manager Pearson, of the Company, finally appealed to the authorities, and in a well-tempered argument showed that 279 ordinary and 106 Lambeth lamps (costing but \$13,454.50 per annum to maintain) had been discontinued, while the electric lights substituted cost \$19,764.03 per annum. As it was proposed to still further decrease the gas service, Mr. Pearson appealed to the authorities to stay their hands until the gas contract had expired. It was finally determined not to further decrease the number of gas lamps in use until the expiration of the contract; and we presume the Gas Company ought to consider itself fortunate in obtaining even this scant measure of favor.

HINTS FROM ALTON, ILLS.—When Mr. William Tracy took charge some months ago of the works of the Alton (Ills.) Gas and Electric Light Company, we had occasion to remark that he was sure to make his individuality felt in directing the affairs of the Company. Now that the several plant improvements have been completed, or at least have been so far advanced that advantage may be taken of the same in carrying on the business, we are treated to the following notice, published by Secretary and Superintendent Tracy, under authority of President Campbell:

"Commencing May 1st, the price of gas will be \$2.50 per 1,000 cubic feet. If bills are paid on or before the 6th day of the month, a discount of 50 cents per 1,000 feet will be allowed, making the net price \$2. An additional discount will be allowed large consumers, as follows:

Monthly Consumption.	Discount.	Net Rate.
5,000 to 10,000.....	5 per cent.....	\$1.90
10,000 to 15,000.....	10 ".....	1.80
15,000 to 20,000.....	15 ".....	1.70
20,000 to 25,000.....	20 ".....	1.60
25,000 to 30,000.....	25 ".....	1.50
30,000 and over.....	30 ".....	1.40

"All consumers using gas stoves for cooking purposes during months of May, June, July, August, September and October, will be allowed a discount of \$1 per 1,000 feet, if bills are paid on or before the 6th day of the month. With this very low price of gas in the city of Alton, we look for a liberal patronage." Of course there is no reason to doubt that this liberal policy will be well rewarded by the people of Alton in a largely increased use of gas by them. This is the second reduction in gas rates at Alton in the last two years, and it should be remembered that the Company is in no wise exposed to competition of any sort, since its proprietors are also in full control of the electric light supply of the city. In his letter to us on the subject, Supt. Tracy says that the consumption of gas is steadily increasing. He has orders on his books for the placing of 22 gas stoves in this month, which is a rather remarkable showing when it is remembered that the total number of stoves hitherto disposed of to users in the city was only 37. Our go-ahead Superintendent is now of the opinion that Alton will have 125 stoves in use by September 1st. This may only be a small straw in the direction of indicating the increasing popularity of gaseous fuel; but such are nevertheless quite as potent in proving the drift of sentiment as are the "larger sizes."

UNIFORM THEM.—We do not suppose that there is much room for argument over the proposition that the employees of a gas company whose duties call upon them to enter the houses of consumers should be uniformed. The last example we have of the necessity for this is reported from Baltimore, where an enterprising thief has, under the guise of a gas inspector, been robbing the houses to which he gained entrance.

[Communicated Article.]

Practical Hints on Purification with Lime.

By FREDERIC EGNER.

Having received a number of inquiries from brother gas men asking if the writer could explain the reason why the amount of gas purified to the bushel of lime used was, for a time, greatly reduced at their works, without any apparent cause therefor, he thought the following item of personal experience would perhaps be interesting to the readers of the JOURNAL. In each case the statement was made that the same kind of coal that had been used for years past was used then; and so it was with the lime, and even the men employed who handled the material; and yet the number of cubic feet of gas purified to the bushel was all at once reduced to less than one-half the usual average. The apparatus and method of operation would be described, and, so far as one could judge from that, everything was as it ought to be; yet still the fact remained that where perhaps 20 and more thousand cubic feet of gas were purified before to each bushel of 80 pounds of stone lime used, now not over one-half of that amount could be passed through the boxes when a change would have to be made.

In view of the above statements the writer was puzzled to account for this state of things for a time until the same happened at the works of which he had charge. It was in December, some years ago, when we had our first experience of the kind mentioned. All at once the purifiers had to be changed more frequently than the increased quantity of gas made warranted; and with each day the matter became worse, until we investigated thoroughly, and found the cause. We were using the same kind of coal—yes, even from the same pile—which we had previously used when purifying 22,000 to 25,000 cubic feet of gas to the bushel of unslaked lime. The lime was fully as good as at any time before; and the men who did the work were the same, and were known to be faithful, hard-working men. And while the trouble lasted these men worked much harder than ever, but for all that we had to employ nearly double the force, and certainly had to buy more than double the amount of lime.

Samples of the lime were carefully analyzed, and found very good, before using; the lime was examined after it was prepared for the boxes

and found to be apparently just right; the foreman of the purifiers assured us that he was doing everything as he had always done it, and there was no reason to doubt his honesty, as he and his men worked much harder than ever before. But the fact remained that the results grew no better, but worse, as the season advanced. So at last we resolved to remain in the purifying house for a time with the men, to see if after all the fault was not there, as nothing could be found wrong elsewhere which could cause the trouble. We did not have to stay long. Within less than half a minute after seeing the men slake the lime we knew where the trouble was, and applied the remedy at once.

The manner of preparing our lime used to be as follows: A bed of lime containing about 50 bushels was made on the floor something like bricklayers make their mortar beds. The unslaked lime was spread in a thin layer, not over 4 to 5 inches deep, and then nearly the whole quantity of water needed was poured over the lime by means of a large hose and some barrels which had been previously filled. As the lime slaked it was turned over, by means of long-pronged rakes made for the purpose. After having been well slaked, about one-tenth of its bulk of screened coke breeze was added, and the whole thoroughly mixed and moistened, until if a handful were taken and tightly squeezed it would stick together and show the imprint of the fingers; and thus prepared we would purify on an average over 22,000 cubic feet of gas to the bushel (80 lbs.) of unslaked stone lime, when using Pittsburgh coal. This was a somewhat tedious process of preparing lime, but it paid for the trouble.

Now, as the season advanced, our foreman, hoping to keep up with the increased demand without employing additional labor, made some *improvements*, as he believed, in the process of slaking lime. He would spread a hundred or more bushels on the floor in layers 8 to 10 inches deep. Then he would turn the big hose on the lot, and when the top of it was about the consistency of stiff mush he would have a man go over the bed with a small hose, at the end of which was a half-inch pipe, and with that he would prod around the pile, sticking it—with the water turned on—to the bottom at short intervals. Then he would spread the coke breeze as before and mix it all.

When mixed, the lime appeared to be all right, the same as when slaked properly; but it was nothing of the kind. The lime was more than half destroyed by the above described method. True, the man could slake treble the quantity of lime with the same labor, but it was misdirected labor, well intended on the part of the foreman, but ruinous as to results, as has been shown. Within two days after stopping the above "improved method," and insisting on the old way, we had our old results back, greatly to our good foreman's surprise, who could not see before any difference between his new way and our old way of slaking lime. But the results did not convince him, as they would almost anybody who may be similarly troubled, for a few years afterwards he repeated his experiment, with the same effect as before. But he was quickly found out, and we shall have no more trouble that way.

We had blamed wet coal, defective center seal, water gas made in connection with coal gas, possible furnace gases drawn in perhaps by running exhauster too fast—everything we could think of—with the falling off in our purification; but here it was, simply the improper slaking of the lime; but for all that it needs the frequent care of the Superintendent to insure the best results, like everything else connected with the manufacture and distribution of gas.

The Market for Gas Securities.

During the week, some improvement was manifested in the dealings in city gas shares, and Consolidated was in demand at something over last week's quotations. Transactions at close of week were done at 96½ to 97, with the tone all in favor of still better figures. Mutual is higher, and Equitable shows no change of moment. Chicago Trust is at 45½—ex-dividend, the payment of which may cause serious trouble. Baltimore Consolidated is unsettled, but it would seem as though the worst had been reached. Providence and Pawtucket (R. I.) shares have not been greatly disturbed over the appearance of the Wakefield Manufacturing Company as a possible competitor in the gas supply of those cities; and Wilmington shares hold their own, although Engineer Conde is out with a notice that the Oxyhydrogen Gas Company, of Wilmington, Del., is ready to take applications for services for intending consumers, the gas to be laid on next fall. This notice is intended as a stock argument—in other words, that the owners of the old Wilmington Company had better sell out. Why they should, we fail to see. They can hold their own easily in any contest that may arise.

[OFFICIAL REPORT.—REVISED BY THE SECRETARY—CONTINUED FROM PAGE 433.]

SIXTH ANNUAL MEETING, OHIO GAS LIGHT ASSOCIATION.

HELD AT THE BOODY HOUSE, TOLEDO, OHIO, MARCH 19 AND 20, 1890.

FIRST DAY—MARCH 19—MORNING SESSION.

The President then read the following address :

PRESIDENT'S ADDRESS.

Gentlemen of the Ohio Gas Light Association:—A year ago we adjourned our last session at the beautiful interior town of Mansfield. Your action at that meeting charged me with the duty of presiding at this. How wisely you bestowed your compliment remains to be seen. Personally I was then, and am now, fully conscious that you might have made a better selection, but with renewed thanks for your compliment, and the hope that your leniency for shortcomings will not be entirely withheld, permit me to extend you a hearty greeting and welcome to this our Sixth Annual Meeting in this thriving city of our Northwestern border. A year is not a long time, and relatively to most of us it doubtless seems short, yet is ample and sufficient to work important changes for us, either for weal or woe. What greater change than the sleep that knows no waking for those who go and also for some that remain? Man, as a gregarious animal, numbers among his keenest pleasures that of greeting the returning friend, and sorrows without comfort at the final parting. As an Association we mourn no break in our numbers, and have cause to thank a beneficent Providence that the year has been thus kind to us. But as part of a fraternity may we not properly pause a moment here and be reminded that death seeks a shining mark, when we recall such names as King, Cushing, Forstall, Parrish and Button? Their names were not on our roll, but all were able, and more than ordinarily bright lights in the fraternity that we call ours. They were well and favorably known to most of us, and perhaps between all of them and individuals of our membership existed ties of attachment of more than ordinary tenderness. May we not appropriately pause and bow the head in silent communion with our own thought, remembering with thankfulness that we are not called to make official record of our own departed? May this opening and coming year be as kind in this regard to us as an Association as the one just closed has been. As an Association representing the interests of companies whose industry is not without competition, and whose environments are necessarily exceedingly various and constantly changing, may we not on the whole be satisfied with the results of the past year, and take courage for the future in view of the present outlook? If we may judge from many individual reports, and from the sentiment voiced by our technical journals, most companies are rejoicing in an increased output of their main product, and those who have steadfastly pinned their faith to the straight coal process are comforted by a marked advance in the value of residuals; all of which tends to reassure investors in gas undertakings. Of our modern industries, some are tributary and some are fundamental. The former having served a temporary purpose, pass out of use and are forgotten. The latter are perhaps variously modified according to exigencies that may arise, but in a general way remain as factors of our civilization, and we tersely speak of them as having come to stay. Steam and gas seem to be permanent examples of the latter, coming into practical use and being developed on somewhat the same general lines; there have been times in the past when the future usefulness of both seemed to be menaced, and the faith of those most interested rudely shaken. That both have thus far stood the test of practicability goes without saying.

Concerning the gas industry and the immense investments involved, the discovery of petroleum, and the economical conversion of mechanical power into electric currents with their phenomenally rapid application to practical uses, seemed so to menace the future of gas that the observant looked on with bated breath, while timid gas men whistled to preserve their courage. Particularly was this true in the early eighties. An interview about that time with an eminent electrician and inventor, familiarly known as the "Wizard of Menlo Park," is still fresh in memory. The relative possibilities and probabilities of gas and electricity in the field of artificial illumination were discussed at length. Among his concluding remarks the man of electricity said, half reflectively, and with manifest candor, "Oh, yes, we shall doubtless let you down easy." This was about ten years ago; to-day, as then, we hear what is to be, and this is natural and in entire accord with that worthy ambition that constantly strives for something better, and without which there would be no advancing civilization, none of the pro-

gress of this progressive age. Our own industry, that industry in the interests of which we are gathered to-day, has been builded in the past and will be developed in the future upon these same general lines. Startling or sensational developments we should not expect, however wonderful or incomprehensible the process submitted for our inspection or investment may appear. But, on the other hand, we may reasonably look for advantage when scientific demonstration and practical accuracy unite to complete a process. In so far as intelligent and persistent industry obtain in the conduct of our affairs, so will the measure of success be. Looking backward over short periods of time, long strides of progress are not manifest, but over *several short periods*, aggregating say twenty years, the difference between then and now is very marked. Measured by the crucial comparisons of dollars and cents, the relation is very nearly as one to three; and so accustomed has the consumer become to frequent and considerable reductions that he continues to ask with the utmost assurance "When will the price of gas be reduced?"

It is significant of the general faith in the future of gas that so much capital is being invested in dependent industries, the managers of which, in their zeal for their specialties, are becoming most potent influences in the matter of educating the public to a higher appreciation of the possibilities of gas. But while the modern idea of combustion is in striking contrast with the phlogistic theories of a past age, the practiced application of the principles of combustion that we make is even more discreditable to our time, and the more especially since it is so well understood that the gaseous form is essential to combustion. It is comforting, however, to note that the industries above referred to, such as the manufacture of stoves, engines, regenerative lamps and various heating appliances, are being conducted with increasing recognition of the principles involved in combustion, and that the near future promises such increased efficiency as will materially hasten the day of cheaper gas, the millenium alike of the manufacturer and the consumer.

And this suggests the reflection that intelligent use on the consumer's part is more or less a factor in the solution of that problem. And further, the increasing and multiplied forms of devices for using gas make this a constantly increasing necessity, not that they are complex or difficult to manage, but to turn the key and strike a match is the beginning and end of all law in this regard with the average consumer.

And since gas from being a luxury has become a necessity, and the manufacturer and consumer from being more or less indifferent, if not actually hostile to each other, have come to the attitude of mutual citizenship, it would seem that this advance toward cheaper gas should be easily made. Or, to put the case a little differently, has the manufacturer performed his part fully when he contents himself with furnishing a good article? May he not go further in the interest of the company he represents and its patrons and dispense information that may not so readily be obtained from any other source?

In the March issue of a New York paper, under the head of "Gas Fuel," appears three columns of such valuable matter in this direction that I feel justified in calling your attention to it, although all present may have already carefully perused it. So much has been written within a few years past upon the subject of gas fuel, and especially since the extensive development and use of natural gas, that it seems almost superfluous to add anything here, and more particularly as we are promised a paper, entitled "Another Year with Fuel Gas," from Mr. C. H. Evans, and which will doubtless give us his practical experience. I had also hoped we might hear from Mr. Wood, some account of his experience with the Loomis system in Sandusky; but perhaps we look to St. Louis with the more eager expectation. That situation then seems exceptionally favorable, and the hands of our own McMillin will steady the helm. Referring to the other papers on our list, I learn with regret that we shall not hear from Mr. Bate on "Theory and Practice in Gas Management," and that he may not even be with us on account of sickness.

Opinions vary greatly, especially among those without practical experience, as to the advisability of gas companies engaging in electric lighting. That such combination is sometimes justified there is no doubt, and perhaps more especially so in the *small town* where there is a demand for both lights, but for either separately a limited one. Mr. Bower's practical experience will surely interest all of us.

"Graduated Versus Uniform Rates" is certainly not a new question for gas men to consider, but the chair ventures the suggestion that when Mr. Faben gets through with his paper new opinions are more than likely to have been formulated. Those of us who have read "Looking Backward," by Edward Bellamy, may have encountered difficulties with the thought that it should be possible for a sane man to clothe the government with such extraordinary powers, but whatever view Mr.

Wilkiemeyer presents in connection with "Municipal Control of Lighting" will command respect, whether all agree with him or not.

The lighting of streets is so important a part of the public service, whether by gas or electricity, that Mr. Hedges' "Statistics" may be expected to constitute a valuable addition to the literature of our meeting. That no two gas companies deliver their output under precisely the same conditions goes without saying, and to hear the "Advantages of a Combined Coal and Water Gas Plant," from a practical standpoint, as Mr. Light will present it, will undoubtedly interest all present. If Mr. Hyde's paper, "Our New Coal Gas Works," is as creditable to his literary ability as the works themselves are to his engineering skill, we are assured a literary treat. In addition to the papers thus briefly alluded to we have eleven questions published, all of which are interesting and of practical importance; so much so that it would seem that there should be no lack of interest so far as the literary programme is concerned, and the success of the meeting thoroughly assured. Many points of interest suggest themselves for presentation here, but with a feeling that the opinions of those who have prepared subjects for your consideration should by no possibility be forestalled, my remarks should be as clearly as may be apart from those likely to be presented by others. Again, most technical questions are very fully discussed in our journals from time to time and may not profitably be reviewed here. There are, however, some matters of interest to us as an Association, and possibly a few thoughts of general interest that may properly be presented by the Chair. A Legislative Committee was appointed at Mansfield, which seems an important one. When the members for this year are appointed, as an insurance of their usefulness, I beg to suggest that both their duties and powers be clearly defined.

The question as to whether under the present statutes gas companies can by vote of their stockholders amend their charters so as to enable them legally to engage in the manufacture of electric light, is one of great importance. I am credibly informed that the Attorney General has decided this question adversely, and for the reason that such amendment would be a substantial change from the original purpose of their organization. The correctness or validity of this decision, if it be such, might easily be tested by mandamus proceedings which it is believed would involve no great amount of expense. The other alternative involves incorporation under a new charter, and I believe has been the course of more than one company during the past year. That there is a growing sentiment particularly among legislators favoring the exercise of municipal control, not only as to street railway and water companies, but gas companies as well, seems an undoubted fact. That such control, so far as we know it in the United States, has not been in the past, and is not now, conducive to the furnishing of cheap gas to the consumer, history clearly proves. This and the fact that some sections of our State laws bearing on the business of gas companies are at variance with each other, would seem to justify an effort on the part of our companies and this Association to secure needed amendments or change. That this Association has been a factor of benefit to the gas interests of Ohio and territory outside of our borders none will deny.

There are 78 gas companies in the State aside from those using natural gas exclusively. Twenty-eight of these are, as yet, unrepresented in this Association. Our Secretary has sent yearly invitations and circulars since our organization. Although a baby Association, we are a lusty little chap, but nevertheless need and ought to have the help of the 28. On the other hand, if united with us, they would derive benefits many times the value of their cost; and I respectfully urge the members present to come up to the help of the Secretary and assist in bringing these outsiders into the fold.

And while in the invitation business, let me say, in a whisper, that there are also a small number who are identified with us by membership in our Association, but who never attend its meetings. To such I say, come up and help to receive and impart the mutual benefits to be derived from our Association, not the least of which are those that come by the mere fact of our coming together.

Not long since every gas company was a finished and completed thing in itself, and so far as the outside world was concerned was literally and metaphorically fenced in. Mystery and reserve their governing characteristics, they were alike unapproachable by consumers and reserved to each other. That such barbarism of the quite recent past has given place to the intelligent, enlightened, and vastly more profitable relations of the present, by virtue of the organization and successful maintenance of gas associations, may be stoutly averred and successfully maintained. A volume might be written and the story of their valuable work and influence still remain untold. None should erroneously suppose that that work and influence is confined to the time occupied by the annual gathering. On the contrary, much of the labor

performed and thought presented in our assemblies, together with valuable information and details from various sources, become crystallized for use in the intervening time. We employ and make a pretence of paying one man, whose time of service extends through the entire year, and to whose earnestness and faithfulness much of the crystalizing effect is due. Through him, by correspondence and otherwise, a large part of our vitally necessary work is performed. Right here pardon me if I step on delicate ground, but when you have carefully considered what shall be presented, I trust you will not be moved to censoriousness. We are all more or less, and within qualifying limits, responsible for the valuable results of our meetings, and but little more remotely for the success of this Association, which exerts so potent an influence on the gas business itself. As already intimated, the present attitude of gas men toward each other is a vast improvement upon that of the former times; but there is still room for more. No man, not even a gas man, can live wholly within and unto himself. To the best of us comes a time when we seek information, and what we seek we should be equally ready to impart. That there should be no office secrets it is not intended to assert, but in a general way, if information is sought—say as to the conduct of manufacture, or business policy, or data bearing thereon, either for local use or as statistics for the general good of the fraternity—are not those who neglect or refuse a reasonable answer short-sighted, and do they not stand in their own light? Surely they have everything to gain and nothing to lose by being freely communicative in such cases. It is a matter of regret that there is here and there one, partly buried in the forgotten past, that seems to think otherwise. It is believed, however, that such are not good gas men. From year to year our Secretary requests papers for our meetings, commencing a goodly time in advance, but generally the burden of anxiety upon that score is not removed until the very near approach of the meeting itself. Excuses are more plentiful than favorable replies, one has bought a farm, another a yoke of oxen, while a third must needs take a wedding trip. And this is not the worst phase of the matter, some totally ignore his letters answering neither one way or another. Such apathy and indifference reflect upon the courtesy and progressiveness of those refusing to respond, and if all were like them would presage ill for the future of the gas business in these days of competition. I trust I have not been simply censorious in these remarks; if I have been I wish to be forgiven. They have been suggested not in the belief that they apply generally, or to any considerable portion of our number, but somewhat with the thought in mind, that even where they appear to apply, it is more because proper recognition is deferred and finally forgotten in the press of multiplied duties, and possible neglect of system in matters of correspondence. May I add, this is the census year, and it is as incumbent upon us to be faithful in imparting such facts as deserve permanent record, as it is the duty of those appointed for such purpose to record them. You hardly need be reminded that the time for the Columbus Fair at Chicago is rapidly approaching, and that some responsibility rests on each of us to the end that the gas interest be represented there in a manner commensurate with the vastness of its magnitude.

In the past, and very generally in the present, the gas business has fallen into the hands of, and has been and is being directed by, men who have drifted into it by chance or from force of circumstances. Bright men for the most part (they never would have been gas men had they been otherwise), but nevertheless not especially educated or prepared for the practical duty of manufacturing and distributing gas. Other industries not as important in the magnitude of their financial investments, or yet in relation to public necessity, find it important, and even necessary for their successful maintenance, that the practical management be committed to men of special education, and that of a high order. Indeed, the general appreciation of the value of technical education is becoming more manifest every year; it is even becoming an essential part of the public school system. Right here in Toledo is a manual training school under the auspices of the Board of Education, the privileges of which are open to any pupil having entered the High School grade; and when such pupil graduates, to his usual scholarly attainments is added more than a fair knowledge of a half dozen different trades. If in the future gas shall realize the full measure of its possibilities, its management must be characterized by a high order of intelligence. This thought is not advanced here as an original idea—more properly as a new idea—but rather to emphasize its importance, and stimulate action that shall culminate in something tangible.

Gentlemen, some apology is doubtless due for the disconnected and perhaps somewhat irrelevant character of this presentation. Recent sickness in my family, and extraordinary attending cares connected therewith, have prevented the bestowal of such thought for the interest

of this meeting as would otherwise have been given. It may occur to some that the more careful consideration and presentation of the technical details pertaining to the practicalities of our industry should have been more particularly considered. Personally, I hold the opinion that the interest of our meeting is more particularly in the hands of the membership. The list of practical papers that we are to have from them fully insures success in that direction, and certainly so if we make the most of the opportunity that their reading will afford. It has often been remarked that cordiality and freedom particularly characterized the meetings of the Ohio Association. I sincerely hope that such will be the case on this occasion. I have already occupied your time at too great length, but feel that you will indulge me in saying that when gentlemen prepare papers for us, it is fair to presume they do it at some personal sacrifice of time and mental labor. Of course we thank them, but it is due to them and to ourselves that we make the most of the papers. To that end there should be the utmost freedom in discussion. Very often it brings to the surface points necessarily only partly brought out in the paper itself. Furthermore, failure in discussion is discourtesy to the writer and loss to the meeting at large. The meeting is in your hands, and will be a greater or less success as you elect to have it. Gentlemen, I thank you for your kind attention.

On motion of Mr. Printz, a vote of thanks was tendered to the President, and the address was referred to a committee (Messrs. Printz, Gwynn and Wilkiemeyer) to examine and report in regard to the suggestions contained therein.

The President—Gentlemen, the next thing on our programme is a paper, entitled "Theory and Practice in Gas Management," by Mr. Bate, of Canton. Mr. Bate will not be present, neither shall we have the paper. We have a paper by Mr. Geo. W. Bowers, and as he is not present, I would suggest that the paper be read by the Secretary.

The Secretary then read the paper by Mr. Bowers, which was on the subject of—

COMBINATION OF GAS AND ELECTRIC LIGHTING IN A SMALL TOWN.

This subject must be considered in two lights. To be able to discuss the matter thoroughly it will be necessary to take the actual experience of the old Hillsboro Gas Light Company and repeat part of its history. It may sound as though the present Company is, through its representative, throwing reflections upon the citizens of Hillsboro—which is not done with any intent—but it is necessary to make the comment so as to thoroughly discuss the title of this paper.

The population of Hillsboro is in the neighborhood of 4,000. The Company (in 1875) secured from this corporation a contract for the period of 10 years, as follows: Street lighting, \$31.50 per post; private consumption, \$4 per 1,000 cu. ft. The cost of plant was \$26,000, \$6,000 of which was a bonded indebtedness. The private consumption at this figure, after the first few months of experience by consumers, showed a falling off of revenue by the Company, and in the course of time the price of gas was reduced to \$3 per 1,000 cu. ft., which made a slight increase each year in the Company's revenue.

I am not an advocate of high prices for private consumption, nor was the Company, but we had to contend with the following: The people in this country have an idea that all gas companies are bloated monopolies, and do not take into consideration that companies of small towns that have in the neighborhood of three, four, or five thousand inhabitants, have not the field to draw from that a city company has, nor do they consider that the amount of gas consumed in a small village in one year would serve a large city for but a day. And, further, expenses must be cut to the lowest point by the people and merchants in places the size of Hillsboro, as business in said towns has not been and cannot be placed on an average with larger cities. Hence the coal oil factor is a measure of economy and a detriment to gas companies.

It is said: "Put the price of gas down and more will be used." Now let us illustrate: We were selling gas at \$3 per 1,000; if we put the price to \$1.50 it would take twice the amount of fuel, etc., to reach the amount of income that the Company was receiving under the \$3 contract. This subject was considered by the Company, and the sentiments of the people were canvassed, but no result in regard to cutting the price was reached. At the expiration of the 10-year contract, the Company made a proposition to reduce city lighting to \$20 per lamp and private consumption to \$2 per 1,000 cu. ft., and had a petition signed by the largest taxpayers and consumers of gas of the village, requesting the Council to make said contract. But, unfortunately, the Council and Gas Company locked horns, and this situation continued for the period of two months. The Company had \$32,000 capital at stake—there being an addition to construction account of \$6,000, with the bonded indebted-

ness paid off—and the club of an electric plant hanging over its head, as they accepted a contract of two years at \$16 per lamp, with the rate of \$1.50 for private consumption. We were willing to make the test in regard to increase in consumption at a lower figure, which was half of the former contract, and at the expiration of the first year our predictions that the amount of gas consumed would not be doubled were fulfilled, the same falling short of the figures of the previous year. At this reduced figure, the Company was still made the subject of complaint, whenever gas bills were presented, as being "too expensive," and "that the Company were robbers," etc. At the expiration of this contract the electric question was brought up again, no thought being given the local Gas Company's interest or investment at stake, as no contract could be reached by them with the city.

This state of affairs brought the Company around to investigate the matter of public arc lighting, with the incandescent for private use. In anticipation of supplying both gas and electricity the subject came up "What would become of the gas interests?" Lighting the streets by electricity would cause a loss to the gas revenue. Would the increased price of arc lighting overcome the gas loss, take care of the running expenses, interest, etc., and make a profit for the Company? In our figuring we found that arc lighting for the streets at the low price of \$10 per light per year, and gas, used at private consumption, at \$1.50 per 1,000 (taking the total amount of gas used the last year of the \$1.50 contract) that the Company would come out even, not making a penny. If we undertook this addition our only salvation was in the use of incandescent lights for private use, as the only expense attached to this part of the works would be the increase of fuel, the Company having necessary steam power and employees. This, for a certain number of lights, would allow us each year to pay a small dividend after setting aside an amount towards the cost of electric plant. We decided to try the experiment, and on the 22d of last March (1889) 60 arc lights were turned on in the village. We have not had experience with the incandescent light as yet, the same not having been put in. The past year corroborates our statement that without the incandescent lights we would not be able to make a penny, as we have not. Now, I hear you say if we put in the incandescent light it will make a deficit in our private gas consumption. That is true, but with our facilities we can make incandescent lights cheaper than gas, and by utilizing employees in the gas plant with the electrical works, the amount of gas manufactured is only averaging the regular cost of production. If you could supplant all gas consumption with incandescent light at a set price per month, it would be better to do so; as, for the same amount of revenue you would receive from gas, your profits would be larger, and you would have your gas plant for fuel purposes at a cheaper rate to consumers and a cheaper process of manufacture.

Now, then, why have we let the past year go by without the addition of incandescent lights? Here we must look at this question in two lights. What is the nature of your citizens in the locality in which you reside? Are they progressive, or does the same state of affairs exist with you that we have with us—the people being conservative? If they are a wide-awake, liberal, pushing class, and have improvements in their locality at heart, the combination of gas and electricity will be a success, but if they are of a conservative order, you will know not what obstacles you will have to surmount, or at what time your investment will be put in jeopardy. We have failed to put in incandescent lights for the reason that we have been unable to secure a certain number of lights (200) at a rental of 75 cents per month (lights to burn from early candle light to 1 o'clock at night). We may be asked "Why don't you sell it by meter measure?" I will here give an illustration and then await your verdict. We were called upon by three citizens some time ago to extend our mains on a certain street. Not being compelled to make extension unless the number of 5 consumers could be obtained, and yet feeling inclined to accede, we stated to the gentlemen that if the city would take three lamp posts we would comply with their request. This the city agreed to do at \$16 per lamp rental. We made our extension at the cost of \$350, received 1½ year revenue from the city, while the revenue from the three consumers is as follows:

The first consumer has been using gas constantly at an average of \$1.05 per month; the second never put gas in his residence, and the third consumed 15 cents in gas the last year. Now, gentlemen, here we are; what can you say? I claim that with 400 incandescent lights at a rental of 75 cents per month, contracted for, it would be an inducement for any company to install said plant; but no company under the sun wants to make an outlay under existing circumstances as given. We have our plant and must make the addition of incandescent light, and work up to a certain subscribed number of lights. We anticipate making this addition in April. Our rental to this city for public lighting is

the cheapest of any lights that I know of, taking in comparison the population we have with other places. We receive \$70 per lamp for 63 lamps, and are required to burn each and every night in the year with the exception of (when it is moonlight) after midnight we are allowed to shut down. This gives us on an average of eight half nights in each month that we do not run. In addition to this we have to furnish gas lighting for the city buildings free of cost. I advocate that a corporation should be liberal in its contract with gas or electric light companies for public lighting, and the benefit given to consumers in cheap rates.

Now, to a brief history of our electric plant: The first important step we made upon the introduction of the electric light in connection with our gas plant was the attempt to thoroughly post ourselves as to the state of the art in other places in visiting other successfully operating plants. We started out with the general proposition that the best was none too good for us. We selected the Thomson-Houston system, with the Ball engine, and after operating the plant one year we have as yet to regret our selection, and have won the honorable mention of probably having one of the best, if not the very best, lights in the country.

Our city was formerly lighted with 170 gas and gasoline lamps of 16-candle power, making 2,720-candle power per night. We have now 63 2,000-candle power arc lamps, making 126,000-candle power per night.

We make it a point to reduce the number of employees and tried to get first-class labor. To do so we found it practical to secure an engineer and electrician in one person. Our labor includes one engineer and one trimmer, and we utilize the night stoker in gas plant as fireman for the electric plant. His duties are not excessive, and as soon as we get our automatic stoker in operation his duties will be comparatively light.

The claims made for the Ball engine were 4 lbs. coal per horse power per hour. Our first statement upon first starting was:

3½ lbs. coal per horse power per hour.
4 lbs. coke " " "
2 $\frac{7}{10}$ lbs., $\frac{1}{4}$ coke and $\frac{3}{4}$ Jackson slack.

This estimate does not include steam raising. We have lost two hours time with engine, and two nights' run with one of our dynamos. We have found that it is necessary to furnish 1-horse power for each 2,000-candle power light, and possibly our system may be slightly in excess of other systems as to close power economy; but its great reliability and excellent operating success more than compensates for this slight loss of power. We use the St. Louis hydraulic $\frac{1}{2}$ -inch carbons, and can count upon 9 to 9½ hours in each carbon. Have had no accidents.

Now, as to the future: We are here and in good shape, with anticipations that our community will take hold of incandescent lighting, to no disadvantage to our private gas consumption; as it is known the country over that where one place of business is well lighted the next door neighbor must have a better light, either with gas or electricity, and thus we hope to increase either one or the other of our modes of lighting.

In regard to the people of smaller towns, it generally takes some time to get them interested in any matter of this kind; but we intend to treat them liberally, and hope by next year to give a successful account of a paying investment of the arc and incandescent addition to gas which makes a success of "Combination of Gas and Electricity in a Small Town."

Discussion.

The President—Gentlemen, this paper is, I may say, a matter of interest to all of us—perhaps of more interest to some than to others. As the author is not present, there may be a little inconvenience in discussing it, but I trust that all will discuss the paper with the utmost freedom.

Mr. Penn—I have had some experience with a combination of gas and electricity in the little town of Washington Court House. Our population is about twice that of Hillsboro. I do not know I can say anything that will add to what Mr. Bowers has said, but in regard to incandescent lighting, especially at the prices they have agreed to furnish it at in Hillsboro, I will say this: Our citizens come at me in this way—we get \$80 for a 1,200-candle power arc lamp, while they only get \$70 for a 2,000-candle power lamp—and say, "Why don't you furnish it as cheap as Hillsboro?" I say, "We don't have to." In Hillsboro some of the parent companies came in, got hold of the Council and treated them nicely, nicer than our gas men can afford to do, got up a fight for a franchise, and forced the Gas Company into buying an electric light plant at an unreasonable price. I thought, when that paper was being read, if there was not some way by which this Association could come to the assistance of the small gas companies when these parent companies come in and force them into buying a plant. They could certainly give them some assistance in the way of advice, if nothing more. We were more fortunately situated than they were in Hillsboro. When we

took hold of the matter I got our contract to run to '95. We put in an electric light plant simply because the people wanted it, and it was going to come anyhow. Another thing, we were enterprising. We wanted the town to boom, and we concluded to put in an electric light plant. Our gas plant was about up to its limits—it is a small works, with only 4-inch connections—and we felt that we had gone so far that we would either have to put in a larger gas plant or add an electric one. Taking all these things into consideration, we thought it advisable to put in electric light. We finished our addition last month when we put in a second machine. Of course I can't give any data as to what we are making. I made a rough estimate of what coke was required—I am using coke altogether—and I think it is as cheap, or cheaper than coal. My impression is that we will make a very good percentage on our investment; but, on the other hand, on the gas part of it, I find we are a little bit short. It is going to "hustle" us, as the saying is, to keep up the improvements for the gas required. Now we have a demand for an extension of mains. That thing is staring us in the face, and we are not getting anything from the city to amount to anything (only about \$1,000 a year), and, of course, that is not going to give us much revenue from the city contract. The private consumption will hardly pay all the running expenses and give us surplus enough to enable us to extend our mains as they should be. Now, of course, as has been stated before, the electric light no doubt increases the demand for gas light, and it is a benefit that way. I can state several cases in our town where parties who were using oil saw, as soon as we got electric lighting in, that there was such a contrast between it and oil that it made them sick to look at their light, and they ordered either electric light or gas. I have one case in mind where a bookstore was equipped with electric light. The next store was a boot and shoe store, the proprietor of which was a very close man, who watched dollars and cents very closely. I had been at him nearly two years to put in gas, but he adhered to the use of oil. He said gas was too expensive and he couldn't stand it; but as soon as the bookstore put in electric light, he came to me voluntarily and said he wanted me to put gas in his store. I did so, and he is a good customer. In several places where we put arc lights in the stores they have abandoned oil altogether. Another place in point was a clothing store, in a long deep room, with low ceiling—a very dark place; they used oil, all except the two front windows. Of course they wanted the people to know that they burned gas there. Their gas bill didn't amount to anything. I would a good deal rather have had their meter than to have had their trade. I put in arc lighting there and they said "Oil don't look well beside electric light, and we would like you to fix up gas burners for us." Now, next door there was a tailoring establishment, and, by-the-way, the proprietor is one of the stockholders in the Gas Company. He put in arc light. He was always a little bit on the kicking order about his gas bill—thought he didn't get enough gas for the amount of money, although he was a stockholder. I noticed since putting in the arc light that he burns two jets in the window and one back at the desk. I intended to have brought a paper showing comparisons in the case of these parties, but in my hurry at starting off left it. I could show you the names and the amount of gas used before they put in electric light, and the amount used since. Of course there are exceptions. This book store that I spoke about don't use any gas at all. They have a very high ceiling and one light lights up the whole store, except in the holidays, when they light the back part of the store with gas. We keep meters in all these places and give them the regular rate, whether they use little or much.

Mr. Booth—I believe Mr. Penn has gone pretty thoroughly over all the ground. He has had a little more experience than I have. We went into the electric light business in November, and put in two 35 light (2,000-candle power) T. & H. machines. We did it as a matter of policy. Other parties were making application for a franchise, and our contract for lighting the city ran out the first of last May. We decided if they came in it would cause a fight, and we determined to put in a plant of our own. We induced the Council to give us a franchise first—that we should have the first right on the streets. We started our plant up about the 1st of December. The first contract was for 36 arc lights. We get \$90 per year for all night lighting, except three nights in the month, at full moon, and since they were put up we have had an addition of eleven, or a total of 47 lights. We have only seven commercial lights. We have not been soliciting for commercial light at all. Of course if any person comes to us and wants a commercial arc we put it in. We have been at a loss to know whether it is policy or not—whether there is not more money for us in gas than electric lighting. I notice where we have put it in has been altogether in saloons. Our saloons are perhaps the best consumers we have, consuming from 5,000 to 15,000 feet a month of gas. They burn gas in addition and we

get about the same amount from arc light and gas together that we did for the gas. There is very little difference in the amount of their bills. The arc just takes off about the same proportion of gas as if they had burned all gas, and we get about the same money per month from our customers that we got before we put in the arc lamp. We can get coal pretty cheap down there, and we get \$1.20 for gas, net. Of course we have not run long enough to determine whether we can make any more out of it than we did out of gas. From the city for gas we only got \$15 per post. Our revenue from that with the number of posts we had, amounted to about \$2,300 a year, while we get now (with the 47 lights) \$4,200 for the electric light, which I think ought to give us a little profit. We started up in November, and we didn't get anything from the city till the 1st of December, when they commenced to pay us for the arc lights. We started up the 20th of November to run the lights, but we only charged for the gas rate to the first of December. From the 20th of November I figured to the 1st of January—a month and ten days—and we had a little margin in that length of time over the cost of running. Of course, that was a fair estimate. Our expenses were larger than they would be now. We had to get accustomed to the business. We are talking some of putting in the incandescent light, because the people want it. They have it around there, and our people say, "Why don't you put it in? You have a monopoly and you think no person will come in, and you won't give us the incandescent lighting." It has been our object to please our consumers, and, if possible, to give them what they want. We expect this summer to put in an incandescent lamp machine, and we think, if we can go over the river to Benwood, we can get enough to pay us to put in the plant, as they have no gas there. I am satisfied that when they try incandescent lighting at the price it is sold at now they will find it more expensive than gas, and I expect there will be more "kicking." We have some people of that sort, of course, in our town, like they have in other places. I was amused at Mr. Penn's statement about one of the stockholders "kicking on his bill." It put me in mind of some of our consumers who act in the same way. In regard to incandescent lighting, it is a question with us whether it is policy or not to put in a plant. I will say that our consumption has been greatly increased in the last year—say, by three million feet. Our meter sale to private consumers would run in the neighborhood of a little over ten millions. We lost somewhat on account of natural gas. A few of them put in the Lungren burner, and we have never been able to get them back. They were some of the best consumers we had, but they wanted cheaper light. Natural gas is very nearly played out. In a cold day there isn't enough there, but in the warm weather we have a pretty good supply. This winter, being open and warm, we have had enough gas for general purposes, except on the real cold days when we had to hunt up wood or coal to keep warm. If it had been a cold winter I don't think there would be much gas used in Bellaire now. Most of the factories there have been thrown out of natural gas, although a few of them use it yet. Only two of the glass factories I believe use it for melting. It is pretty nearly played out, and I understood the other day that the Natural Gas Company in Martin's Ferry had instructed their agent to make no new contracts with new consumers, either for lighting or heating purposes, as they thought they had about all they could take care of. I would like to hear from somebody who has had experience in regard to incandescent lighting, where there are gas companies, to give us that experience.

Mr. Wilkiemeyer—My remarks will be based on the teachings of observation, and not experience. At Portsmouth, O., we are entering the electric lighting field, and I must confess I feel a decided shakiness about the knees. The Directors of the Portsmouth Company placed at my disposal a certain amount of money for traveling expenses, etc. My instructions were, "Investigate the different systems of electric lighting and steam engines." One result I have achieved—their money I spent. I studied the different makes of engines, their utility, economy, and efficiency; and when near my journey's end—as yet not having arrived at any satisfactory conclusion—I visited Raleigh, N. C. There I found two Otto gas engines, 50-horse power each, speeding three 45-light dynamos. I had been told that gas engines would not give the steady power necessary; but the light was steady, and, I thought, superior to any I had seen in my travels. Incandescent lamps were fed from the same circuit, and only by very close observation could I see an occasional waver, which would not be taken note of by a person not intent upon discovering this defect. Credit should be given this Company—as I understand the case—for the enterprise displayed and their results. At the time they installed the electrical plant a 50-horse power Otto gas engine could not be had in this country. Nothing daunted, they imported one from London, England. Each engine is taking but 17 cubic feet of gas per horse power. At Portsmouth we are following

the footsteps of Raleigh (N. C.), Spencer (Mass.), and Norwalk (Conn.), by utilizing a gas engine—furnishing electric light, and still selling gas through the medium of the electric light. I expect to do this—operate 7 hours per night, and with the following most liberal figures attain the consequent results. Our engine is a 50-horse power Otto gas engine. Now, then, supposing it will require 20 cubic feet per hour per horse power, we have a consumption of 1,000 cubic feet each hour; for 7 hours, 7,000 cubic feet. We will need to charge, say, 5 extra retorts, taking a total of 1,560 pounds.

1,560 pounds of coal = 19½ bush., at 5½ cents.....	\$1 03
Cost of labor of charging the 5 retorts	35
Total.....	\$1 38

We will have returned in residuals—

9 galls. tar, at 7 cents.....	\$0 63
10 bush. coke, at 5 cents.....	50
	1 13
Total cost of fuel for the 7 hours' run	\$0 25

That electric lighting plants, to be a commercial success, need most careful watching and closest economy is evidenced from the following item; furthermore the market value of stock is its true value. The item is from a recent issue of the *Cincinnati Enquirer*, and reads as follows:

"Novel Auction Sale! Some parties Dumping Electric Light Stock, and others Taking it in.—A sale of electric light stocks and rights was held at auction yesterday at the Bodman Tobacco Warehouse that attracted considerable attention from the novelties that were offered and from a certain story that was in circulation. It was stated that the gas companies had suffered from the establishment of electric light plants, and now that the former were getting the best of the latter, probably by buying them out. It appears that there is an organization called The Ohio Edison Installation Company, so called because it has the right to install Edison electric light plants in the cities of Ohio. Some that it has established had to be sold out. The reason given for having the sale at the tobacco warehouse was because so many tobacco men were interested. The sales were \$74,500 Middletown (Ohio) Electric Light Company stock, 6 cents on the dollar; \$10,600 Tiffin (Ohio) Electric Illuminating Company stock, at 60 cents on the dollar; \$16,000 Piqua (Ohio) Electric Illuminating Company stock, at 23 cents on the dollar; and \$10,000 Circleville (Ohio) Electric Light Company second mortgage bonds, at 15½ cents on the dollar. There was offered \$8,000 of the stock of the latter Company that is in litigation, but there wasn't a bid on it.

"Besides the sale mentioned the Installation Company sold its entire rights in the Middletown Company for \$25, in the Piqua Company for \$35, and in the Tiffin Company for \$125.

"There were in attendance at the sale Messrs. H. H. Hoffman, Henry Worthington, J. Hamilton, E. C. Williams, Judge Harmon, J. O. Wiggins, H. R. Morehead, and many others."

I happen to know of the experience of Circleville. They made an investment in an incandescent electric light plant of \$55,000, and it was sold at receiver's sale for \$17,000. That seems to be an experience well worth looking at by gas companies. At Circleville they are now thinking of putting in an arc plant. The stockholders of the electric light company there have control of the Gas Company—I think they paid \$40,000 for the stock. Now that, with the \$55,000 that they have invested, makes \$95,000. With the arc light coming in there—the town has a population of about 6,000—what are they going to do?

Mr. Gwynn—They will go up.

Mr. Wilkiemeyer—Another thought comes from the reading of Mr. Bower's paper. Do not we, as gas men, make a mistake in cutting our prices under compulsion? Ought we not to make these prices before we are compelled to make them, and thereby gain the friendship of the people we are dealing with? When we fight we don't want to be beaten—neither party wants to be beaten. It creates bad feeling that is very hard to overcome, and I think that is where a mistake is made. If we economize as much as we can, working hard and doing all that we can to please the people, and giving them gas at the lowest price that we can possibly give it to them at, the people will not be unreasonable, and they will stay with you, and when the electric light company comes in they won't get anything from them. The Gas Company, of course, must have foresight enough to know that if electric light is wanted in that town, they must give it to them; but if you don't give it to them, and another company comes in there, don't run.

Mr. Booth—One remark made by Mr. Wilkiemeyer in regard to the cutting of the price of gas I favor very much. Our experience in that line was that in 1884 we made a contract with the city to furnish gas at

\$1.50 per 1,000, net, to city and private consumers. When natural gas came in two years later we voluntarily cut the price to \$1, although our contract with the city for \$1.50 lasted three years longer. When the natural gas failed so that it had to be abandoned, we advanced the price to \$1.20. There was no "kicking." We had a contract with them for coal gas at \$1.50, and they expected to pay \$1.50, but instead of that we only advanced it 20 per cent. and put it at \$1.20. I think it is a good plan for a gas company, whenever they find it is necessary to make a reduction, to make it without being forced, and thus get into the good graces of the consumers who won't think you are trying to take advantage of them all the time. I think it is a good plan to do things without being compelled to do them.

A vote of thanks was passed to Mr. Bowers for his paper.

The meeting then adjourned until 2 o'clock P.M.

FIRST DAY—AFTERNOON SESSION.

The Secretary—We have a telegram from Mr. J. M. Bate, who was to have read a paper here on "Theory and Practice in Gas Management," but who is unable to be present. His telegram reads as follows:

"Comrades of the Ohio Association:—Theory in gas management is a delusion. It is all hard practice. I am proving it by trying to engineer a gas lighting contract against an electric and gasoline combination. If any of you know how to pray, make a silent petition for me in this time of woe. Am sorry not to meet with you, but my spirit is there. Wishing you a successful meeting and a good time, I am yours, fraternally—John M. Bate."

We also have a telegram from Capt. Wm. Henry White, of New York, as follows:

"Accept my sincere wishes for a large and interesting meeting, and my regrets that I am compelled to be among the missing.—Wm. Henry White."

At this point Mr. Chas. R. Faben, Jr., read his paper, entitled—

GRADUATED VS. UNIFORM RATES.

The subject presented in this paper is one that has interested, at different times, many of the general managers of gas companies throughout the whole world. It has been the subject of discussion among them during conversation, and also in open convention at the meetings of many of the largest gas associations.

There are those who argue strongly in favor of a "uniform rate" to all consumers, large and small, for any and all uses and purposes to which gas can be applied, while others again have presented equally strong argument in favor of "graduated rates"—the amount of gas demanded, the time of day in which the gas was likely to be consumed, and the purpose for which it was to be used, being a governing factor in the rate per 1,000 cubic feet to be charged for such gas consumed, etc.; and yet we are almost without precedent and reliable data to govern our actions, should any one of the gas companies represented here to-day desire to engage in the practice of "graduated selling rates."

It is true, nearly every gas company operating to-day does make some comparatively small concessions in the lines indicated. Some companies make a lower rate, if a certain large quantity of gas be consumed in a given time, irrespective of the purpose for which it is used; others again make a special discount upon bills for gas consumed for heat and power purposes, irrespective of quantity used; and nearly every company makes a discount for prompt payment of bills, some of them being very liberal in this regard. Some have made great effort to introduce into common use gas stoves for cooking purposes, selling stoves at or below actual cost, renting stoves, etc., yet no company of my acquaintance has adopted the broad policy that the time and hour seems to demand.

Great inroads have been made upon the gas lighting business of the cities and towns of our country by the advent of the arc and incandescent electric light. Some of the managers of gas companies obtain all the comfort and solace they require when they state that the arc light has educated the community to demand more light, with the result that their output of gas is just as great, or that they have experienced a slight increase over the preceding year, etc. But this, I say, is not enough. Why should we stand comparatively still, while our competitors in the lighting business push forward, and are enabled to show a very large increase of lighting business in the same territory that we, as lighting companies, have so long occupied?

The earning capacity of the plant, and of the capital at present invested, should be largely increased, since the lighting business has been very largely increased, as clearly indicated by the amount of lighting that is being done at present, electrically.

If electric light companies offer a light that answers the purpose bet-

ter than gas, then we must look for another market for our product. If, to secure business, they make generous concessions to very large consumers of light, then, if we can afford to do so, we also should be prepared to make like concessions and secure the business. If a large and profitable increase of business is not to be secured to us in the field of lighting, then is not the fuel and power field the one for us to occupy? And is not the present the time for us to make the necessary move to secure the same?

As previously stated, we are almost without precedent and reliable data to govern our actions, should any of the companies represented here to-day desire to make a new departure, adopt a broad and liberal policy, and occupy the field as a "Lighting, Fuel and Power Company." From a newspaper of recent date I clip the following items:

"*Relative Cost of Producing and Distributing Fuel Gas.*—At a recent meeting of the Engineers' Club, of St. Louis, Mo., Mr. Emerson McMillin, President of the American Gas Light Association, and of the Laclede Gas Light Company, of that city, expressed his intention of endeavoring to solve the fuel gas question in St. Louis, in the near future, by making and distributing it from an existing plant in that city, and if the people supported the enterprise it would be continued and extended.

"Replying to the question as to the relative cost of manufacture and distribution, Mr. McMillin stated that in an extreme case which had come under his observation the distribution cost four times as much as the original cost of gas. In well designed and equipped works these items of expense should be about equal. The European practice was to estimate that one-third of the selling price of gas should pay the interest on the investment, one third the cost of manufacture, and one-third the cost of distribution. He called particular attention to the fact that mains used for distributing fuel gas could be used for probably 15 hours of the 24, while those used for illuminating gas were used probably 3 hours. The fixed charges, therefore, per thousand cubic feet of gas delivered, would be greatly reduced."

"*Fuel Gas in Kansas City.*—That gas will be manufactured especially for fuel purposes in Kansas City before the close of the present year is confidently expected. With all other modern conveniences in this age of advancement, the old-style way of using wood for heating and cooking is behind the times, and fuel gas seems to be destined to take the place of these bulky commodities to a very large extent. The Kansas City Gas Light Company's new gasholder, at the corner of Twenty fifth and State Line streets, with a capacity of 1,000,000 cubic feet, is nearly ready for business," said one of their officials recently. One of the purposes of the Company is, as soon as practicable, to manufacture gas for fuel.

"Officers of the Company believe that the time is not remote when they will feel justified in beginning the manufacture of a fuel gas which may be supplied to consumers at a cost not exceeding 75 cents per 1,000 cubic feet. The initial outlay for such an undertaking, including the cost of about 20 miles of mains to be laid in the thickly populated residence districts, would approximate \$200,000; but it is not unlikely that such a task may be begun before the end of 1890."

These two items are only a sample of many that are constantly before us, and they clearly indicate the great field that is open to us, if we will but make the proper effort to enter and occupy it—not in a small way, as if by experiment, but in the broadest sense of the term. We occasionally come across such a news item as the following: "*Fuel Gas at Montgomery, Ala.*—The Montgomery Light Company have a daily output of gas of 100,000 cubic feet, of which 40,000 cubic feet is sold for fuel purposes. They charge \$2 for illuminating and \$1.20 for fuel uses. Twenty (20) heating and 108 coking stoves and four engines are now supplied. The gas stove trade is handled by the Company, and stoves are sold at cost. They examine the stoves regularly, and have a rapidly growing stove trade. The monthly consumption of gas per stove, they find, averages 3,600 feet. They think of trying the rental plan this season."

Here we have the case of comparatively a small gas company who have given the matter some considerable thought and attention, and have decided to try an experiment, to wit, making a discount of 40 per cent. from price list to all persons who will adopt gas as a source of heat and power. No doubt there are many such cases in actual successful operation in the United States, but yet we have no compilation of these facts, and we are without data as to practical working results, and, therefore, are without the means to make deductions to govern our own particular case, should we decide to do so, but we must also resort to another "experiment."

The importance of having this sort of data properly compiled, together with the peculiar local conditions existing where the "experiment" is made, must be apparent to all; but how to collect this data, and in what form to present the same to existing gas light companies

in a clear, intelligible manner, so as to enable them to make a satisfactory "schedule" for their respective localities, I am unable to present in this paper.

Gas light companies would be justified in their action were they to make special rates for gas used for special purposes. Railroad companies make special rates on classification of goods carried. When sulphate of ammonia is shipped to a buyer, the rate is, say 40 cents per 100 pounds; but when the same material, in the same packages, in the same car, is shipped to the same buyer, and he intends to use the material as "fertilizer," the freight rate is only 20 cents per 100 pounds. If the experience, practice and business laws governing in the case of railroads, is good, why will not the same apply equally well with gas light companies, who are forced to depend upon purely local trade for patronage and support?

The saying that "large bodies move slowly" is applicable to the general policy exhibited by many of the gas light companies in their past history. We are sometimes told that the present generation of gas makers are living down the sins committed by their predecessors in the business.

This leads us to the question, Are we not, as the progressive gas-makers of the present committing sins that will entitle future generations of gasmakers to truly say of us that they also are living down the sins committed by us? A look at the past will convince most of us that we have sometimes blundered and committed great errors; that our prejudice was much stronger than we are willing even now to acknowledge.

Just review, to a moderate extent, the subject of "Water Gas." When the "Lowe Apparatus" was first presented to the notice of the average legitimate coal gas man, what was said of it? We said, "It is nothing new. It don't amount to anything." Prejudice was our master at the time.

We did not say to Mr. Lowe that the apparatus presented was crude, and that it simply needed to be improved by better proportioning its parts, and in some other small matters of detail. We said that it was no good, and that settled it. But Mr. Lowe and others, not acknowledged as great gas men at the time, thought differently, and they worked and labored upon "water gas apparatus" until they have produced systems that many of the former legitimate coal gas men have since adopted, and they now swear by carbureted water gas as against their original idol, coal gas. The present direct water gas apparatus produces the same volume of carbonic oxide that it used to produce, and carbonic oxide is just as poisonous as ever, but with more calm reasoning, and dismissing our prejudices, we can now see that the presence of carbonic oxide in our gas is not seriously objectionable, but is in a measure desirable as an ingredient in an illuminating gas.

The subject of electric light was also treated by gas companies generally with the same sort of biased reasoning. It was pronounced as being simply "A demonstration of a scientific principle," "The light for the rich," etc. To-day we are confronted with the propositions of the so-called "fuel gas company projects." They are not entertained by the existing gas light companies, any more than were the "water gas people" of a few years ago, and as they (the promoters) have faith in the "fuel gas business" (with the matter of light as a sort of a side issue), they are forced to apply for a separate franchise, if they desire to engage in business at all. I do not say these things as an indorsement of their processes nor their methods and practices, but simply to raise the question, Are we to-day repeating the same sort of a mistake that we did a few years ago upon the subject of "water gas?" If we are, then we should at once proceed to change position, and not again wittingly place ourselves on the wrong side of a very important subject.

The more common use of gas for fuel and power purposes is near at hand, but if the narrow policy that has been the practice of the average gas light company in the past, is to be continued as the true policy for future operation, then fuel gas companies yet to be formed, will be the ones to do that business, but if existing gas light companies will adopt a broad and liberal policy, incorporating some schedule of "graduated rates," the price charged per 1,000 cubic feet of gas to be based, in a measure, upon the value of the service rendered the consumer, then existing gas light companies will be the ones to do the business, and in this manner largely increase the earning capacity of the present investment.

Discussion.

The President—Gentlemen, probably there is no subject that has been presented here that has commanded more thought or been

more widely discussed in the past than this very question, and I trust we shall have a warm and earnest discussion that shall be fully as valuable to us as the reading of the paper has been. If I be permitted, I will ask Mr. Hyde to say something to us that shall reflect his views and opinions.

Mr. Hyde—In a city of the size of Cleveland, as a principle I think there should be one price in the ordinary use of gas; but as this paper indicates we should be looking to the future. We should not let time pass, and not take advantage of the privileges and opportunities that present themselves. The question of fuel gas has been brought before the various Associations, and has been discussed in the GAS JOURNALS, and whether we are to have a special gas fuel or to use the present illuminating gas or fuel, has been discussed somewhat. It seems to me that with our present coal illuminating gas plants, and with all the conveniences for manufacturing and distributing gas, we should take advantage of the means we have and deliver to our customers fuel gas. That, of course, necessitates having two prices for the gas. Now we are very well aware that as the prices of gas have been reduced from time to time the consumption has been largely increased. It would seem to me that a desirable way would be to have two prices for the illuminating gas, one for that used as fuel and the other for that used for illuminating purposes. The ordinary price for illuminating gas is too high for that same gas to be used for heating purposes to any great extent; and while we have the means and opportunities of making and distributing gas, if the consumption should be largely increased for the day-time, the outlay would be increased simply in the labor attending the manufacture of the gas at the works. Now I think a policy will have to be, or should be, adopted by gas companies to meet this desire to have fuel gas, by fixing the rate of all gas used for fuel purposes much lower than it is for illuminating purposes. What that should be—how low it should be—is a matter that will have to be considered and discussed before the rate will be fixed. We all know that since the use of gas for cooking purposes the send-out for the day is largely increased. In our city the increase has been quite extensive, and I feel sure that should the price be reduced largely the gas will be used for other purposes than simply for cooking. I suppose for the heating of houses, the amount is comparatively small, but I think, with the rate reduced to say perhaps half or two-thirds, and then attention given to the construction of heating furnaces, the day may be not far distant when our houses may be heated by our illuminating gas. We have the pipes and meters in the houses and a very small outlay would be required to attach it to the furnace, or to a furnace which may be designed for that purpose. Of course the ordinary coal furnace is not adapted to the consumption of gas with economy, as it could be by some study and experimenting which the ingenious gas men of the present day are putting on that subject. My opinion is gas men should give thought and attention to this matter, and the probability is only a short time will elapse until the consumption in the day-time will be equal to the consumption at night.

Mr. Penn—I am much interested in this question. I have for about three months been contemplating making a reduction in price, and have been waiting until this meeting so that I could hear the question fully discussed, as I am in hopes it will be. I have been thinking the proper way would be to make a uniform rate for illuminating gas to all consumers, both large and small, and a uniform reduced rate for all fuel purposes. I would like to hear the opinion of others before I adopt that schedule.

Mr. Tayler—I think the question of graduated prices is very largely a local question. In some places it would be exactly the thing, in others it would not. I am speaking of graduated prices for illuminating purposes. In my town (Warren) we have no large consumers. There are none large enough to make it any special object to reduce the price of gas to them—that is, to make a graduated rate; but I think the only way to use illuminating gas for fuel purposes is by reducing the price. For the last month or so I have been heating my office with gas in a new way, putting in pipes and heating by hot water—putting gas under my boiler; and while it is a very convenient way of heating, and one that perhaps a gas company could afford to use for its own heating, it would stagger some of our customers if the bill were presented to them. I find it takes about 1,500 feet a day to heat my office and shop. That, at any price that we could sell gas at in Warren, would not bring many customers. But if the price of gas could be put at something that approximated the price of coal, we could furnish gas for heating purposes. The question with me is—how to get down there. I don't see how we can make a coal gas in a town of our size at anything near the cost of hard fuel—without it would be a change in process, making an entirely different gas, and that means almost another gas works.

The Secretary—One of our consumers at Columbus said that he would agree to let us heat his house with our gas, by putting it under a boiler, as in Mr. Tayler's case, and heating the house with steam. He would agree to let us undertake it and allow it to re-

main there, if it did not cost him more than twice as much as coal. We made the experiment, using two or three kinds of home-made atmospheric burners under his boiler. Experiments were made to a considerable extent, and yet we could not come within the limit that we had fixed. It cost more than twice as much as coal.

A Member—At what price?

The Secretary—One dollar a thousand.

Mr. Christian—I would like to know whether Mr. Tayler used hot water circulation or steam?

Mr. Tayler—Hot water.

Mr. Christian—For how many hours?

Mr. Tayler—Twenty-four.

Mr. Christian—That is very favorable towards gas. I did not think it could be done for that. What sized rooms are those?

Mr. Tayler—Two rooms about 16 feet square. The shop is about 24 by 16, and hall-way is equal to a room 16 by 18.

Mr. Christian—Last Spring I went to Iowa to change a plant that had been making hydrogen gas—it was a town of about 12,000 inhabitants—and I don't think they had been using it more than a year. It was an illuminating plant, not one for fuel purposes. They used the Springer apparatus and made the hydrogen gas with the Springer cupola. They used hard coal, costing, I think, \$8 per ton. All the coal that we used after I went there they had when I went there. We changed from an oil process. They sold their gas at 60 cents a thousand feet and that winter they lighted a large hall with some of their burners. The expense, I think, with the gas at 60 cents, was about three times the cost with lighting with coal gas. Of course the soft coal was cheap. You could get coal at \$1.35 a ton, delivered, so that hydrogen gas at 60 cents in that town never could have competed with soft coal.

Mr. Evans—Mr. President, the subject has somewhat taken a fuel gas turn, and I may have a word to say. I don't think that fuel gas, as manufactured even at the lowest possible price to-day, can be used to heat an office by steam. Of course it is evident that to produce it you have to raise the temperature to the boiling point, or 212°, and that in the changing of that water from the boiling point of 212° steam it will equal a latent heat of 966°. So that in changing water into the form of steam you require a great deal of heat, and also pass the products of combustion out of your chimney at a high temperature, at least as high as that of your steam. So that as fuel gas is produced, or any other gas, I don't think that we to-day can compete with coal in this way. I would like to ask Mr. Faben if he is using graduated rates, or is making any attempts in that direction?

Mr. Faben—No, we are not. I said to the Secretary at the time it was in bad taste for me to write a paper indorsing some pet principle of his that I did not have in practice. But I think we should be excused a little as we are well supplied with natural gas. It would be senseless for us to attempt to do a fuel business, because you can buy natural gas for 12 cents a thousand, meter measure. The subject was an entirely new one to me, suggested by our Secretary, but in thinking the matter over the more important the whole subject seemed to be; and without making a very exhaustive and tiresome paper I hardly knew how far to go with it. One of the most important things that presented itself to my mind in the preparation of the paper was the lack of data as to the experience and experiments that are going on all over our country. Occasionally a newspaper will take it upon itself to send out a list of questions, asking the companies to kindly fill in the blanks. They will ask them how much of their gas is burned in day-time and how much at night, what portion of it is used for fuel, and what portion for light, and what portion for steam engines. Well, it is one of those matters that they have not given any particular attention to, or kept any account of, and the result is, as my friend here says, they keep their postage stamps. If some manner or mode was suggested whereby the data covering the experience of all those companies making these experiments in graduated rates could be compiled and published, so that every man could make his own deductions for his own particular case, it would be a good thing. There is a figure somewhere lower than the ordinary selling rates that could be adopted for fuel purposes. The best avenue I see presented now is through the eleventh census. We will see, for the first time, electrical statistics. The electricians are thoroughly alive to the importance of this matter in connection with their business. Ten years ago they were not in the business, and no data were required at that time. But the commercial growth of their business demands that they have a full and exhaustive compilation of the present condition of the electrical industry. We were in the business of gas making more than ten years ago, and the kind of information compiled and in store to-day on the condition of the gas business ten years ago, at the time of the collection of the last census, is very poor material—for what reason I cannot say, but another census is about to be taken. Now, if our business had been properly canvassed ten years ago, and we knew the condition we were in at that time, both in the matter of light and fuel service, we would know just exactly where we stand on the question to-day—not only as lighting companies, but how far we have progressed with the fuel business. The trouble has been that the majority of companies have not kept a very exhaustive record of what they were doing, and when a circular is sent out to them they cannot well fill it. I would like to impress on the minds of the members that each individual can make a very much closer guess in his community, than can the gentleman who sends the circular out; and if, in collecting the material for the eleventh census—the schedules sent out are rather exhaustive—if each man

will fill in the answers that are required, to the best of his ability, and those that he cannot give accurately, if he will write after them, "approximate," and any other data that might suggest itself to his mind, it would enable the census collector, at some later date, in his newer and later schedules, to incorporate those features.

The Secretary—Coming back to the subject of graduated rates, I would like to ask Mr. Faben if he would recommend that a company should fix a graduated rate based simply on the amount of consumption, leaving out of question the fuel part of the business?

Mr. Faben—I hardly understand the question, Mr. Secretary.

The Secretary—Would you give a lower rate to the man who burned 10,000 feet of gas than you would than to the man who burned only 1,000 feet, for illumination?

Mr. Faben—That certainly is in line with the modern practice of doing business. We have, as lighting companies, a well-organized and formidable competitor in the matter of electric lighting. Some of our members feel that incandescent lighting is still an experiment. I don't think so. I think the incandescent light will do a very large percentage of the nice lighting of the future; and I also believe that gas will be more commonly used than it was ever used before; but I don't think that we ought to content ourselves in doing just as much business as we did last year when the field is open to us to do a great deal more business. The fixed charges on a plant are the same, whether we send out one hundred million, or whether we send out two hundred million, provided that other hundred million is in a new field, and furnished during hours when our mains are now comparatively idle.

Mr. Prichard—We have used a graduated rate at Ironton for four years, and have had no reason to change or go back.

Mr. Printz—We at Zanesville have not what you would probably term graduated rates. We have a fixed charge of \$1.25 per thousand feet for gas consumed for all purposes. But we allow a discount of five per cent. on bills of \$25 per month, and ten per cent. on bills of \$50 and over. We have not made any graduated rate for fuel and for illuminating purposes. We thought if we made two rates that it would require, in a house where they were using gas for fuel and illumination, two meters. That would be an expense we didn't think we ought to incur. Again, we hardly thought it fair to allow a man a low rate for gas consumed for fuel. For instance, he consumed say \$5 worth in a month, and another man would consume twice that amount for illuminating purposes in the daytime. It is a question we thought of a great deal, and we settled in our minds the better way was to charge as low a rate as possible for all purposes. Mr. Tayler's idea of heating his office, and the figures he has stated, brought to my mind the fact that we have been heating our office at home. It is a room 17 ft. by 26 ft., and about an 11 foot ceiling. We heated it with a large reflector stove and the gas bill for six months, for heating and illuminating purposes, amounted to \$40. Although we paid the year before \$30 for steam heating purposes alone, we felt that we were really saving money by heating our office with our own gas. Quite a number of our people are using our gas for fuel purposes in a small way, for heating bath rooms or bed rooms, which they use just for a short time in the evening; and we have, all told—that is for heating and cooking purposes—some 400 stoves in use in our place, and the people are very well satisfied with the price we charge them, \$1.25 per 1000.

The President—If I may be permitted I would like to express just a thought here. All this is exceedingly interesting, but after all, the absolute cost developed into heat units is the thing that underlies the whole matter. I have given some attention to that thing, and I regret exceedingly that I have not brought the data with me. A stove designed for heating purposes alone was brought to my notice, and I placed it in a room some time ago, and kept a record of the gas consumed, and the temperatures. This room is say 18x26, and perhaps 10 feet high. It is an outside room, that is, all sides exposed, practically, to the open air, and is in a brick building. There are nine windows and an exterior side door so that it is a fairly exposed room. Of course this is not definite, but I give you these facts that you may form your own judgment. I was really quite surprised at the measure of economy that was manifested. It was more expensive than coal, perhaps, applied in an open grate, and certainly more expensive than steam or hot water circulation, but not so vastly out of reach as that we might not take to ourselves a little courage that there is a field for manufactured gas heating in the future.

Mr. Faben—Mr. President, Mr. Evans has had some experience with graduated rates, as I recollect it. I believe they sell fuel gas at 30 cents, and add about 33 per cent. for the same gas used for lighting purposes. He might tell us something of his experience in that line.

Mr. Evans—Mr. Faben is a little in error. We do use some graduated rates, simply to this extent: The consumer is obliged to burn 5000 feet of gas per month in order to get the lowest rates. It is billed to the consumers at 50 cents per thousand, if they burn under 5000 feet, with a rebate of 10 cents if paid on or before the 10th of the month. Over 5000 feet is billed to them at 40 cents a thousand, with a rebate of 10 cents, if paid on or before the 10th. We make no distinction between lighting and heating, although we contemplate doing this on our illuminating gas main that does not parallel our water gas. We have discussed this very point, and I was very much interested when I learned this subject was coming up, because it is one which I think has brought about a great deal of thought and study on the part of gas men, and I have yet to see the solution of it.

Mr. Tayler—I would like to ask Mr. Evans his opinion as to the practicability of using gas for heating by hot air or hot water circulation. In either case I imagine it is cheaper than steam.

Mr. Evans—I imagine that heating by hot air or hot water would be the best method, as you can send the product of combustion out at almost as low a temperature as the temperature of the room. The necessity exists of extracting all the heat, so that the products of combustion will leave the room at as low a temperature as possible. A great deal depends upon the application. If you can apply it to heating by hot water, so as to absorb all that heat, so that when it reaches the point of exit the temperature is low, and yet not so saturated with the products of combustion that it will condense at that point and stop your draft, then you have accomplished all that can be done. Of course, in my paper on fuel gas this thing will probably come up again, as I have gone into the matter, not very deeply, but as much as my time will permit. I will probably have something to say on that point when the subject comes up for discussion.

Mr. Faben—On the matter of data, I believe we have with us Mr. Graeff, who has been selected as the person to collect data of the gas industry. I would like to have Mr. Graeff, if he will, tell the Association what has been done in that direction and what he would like the Association to do to assist him in the collection of statistics.

The President—I think the Association would be glad to hear from Mr. Graeff, and co-operate with him as far as they can.

Mr. Graeff—Mr. President and gentlemen: So far as the first part of Mr. Faben's remarks is concerned—as to what has been done towards the collection of the statistics—I would simply say "nothing," except getting the schedules in order; because the data has to be collected, in the gas industries, for the year ending June 30th, and of course the schedules will not be sent out until the close of June. The preliminary schedule, which will be sent out prior to that time, for information upon which the other schedules will be partly based, will simply have in it a reference to the number of gas stoves and gas engines in the town, if they can be correctly or approximately reported. It is not expected they shall be closely ascertained. The regular schedule, so far, only contains inquiries as to the price of gas for lighting, and the price at which gas is sold for heating power purposes, with the quantities consumed in each direction, so far as can be ascertained, during the twelve months. But it strikes me that a request should go from this Association to the Superintendent of the Census, asking him that inquiry in this direction should be made as thorough as possible, and that the results obtained from such inquiries be made public as early as possible in a special report. I think he will very readily put on the possible little extra clerical force that will be necessary. I think that such a request will have considerable weight, and I would like to see it made. Of course you know that in the matter of these statistics, names of the companies are not made public.

Nothing is made public in the matter of particulars—the entire State of Ohio will appear as a unit, for instance, so that no one will know how much gas one company or another is selling, and no one will get at the minutiae of your business. Of course, you are guaranteed against that by the Government. But in a matter of this kind, the different rates at which gas is sold throughout the country could be very properly gathered together without "giving away" the business of any particular company. It strikes me that such a request would materially advance the matter—the point toward which Mr. Faben seems to aim. I will do all in my power to have such a request granted, if made.

The President—It would seem as though here was a suggestion that it might be well for us to act upon before we adjourn. In this very matter my attention has been called to a case that presented itself after the introduction of a stove, or stoves, that were put in at the graduated rate, maintaining the regular rates for illuminating, and with the special view of increasing the sale of gas by "booming" the fuel trade. A prominent consumer came in very shortly, who was very quick to "catch on" to the situation, and desired that his gas be passed through a stove as well as through a meter: I think the point is obvious. (Laughter).

Mr. Strong—Mr. President, I think this manner of graduated rates is one that is peculiar to each individual city. It is one thing to manipulate a gas company where you can have the situation to your own liking and quite another thing when you have not. This matter of graduated rates came up before our company a year ago. We had been giving a little concession prior to that for gas used as fuel, but not enough to cut any figure in the bills, or in the increase of gas so used. A year ago, with a change of process, we concluded to "burn our bridges." So we reduced the gas used as an illuminant to \$1.25, net, and for fuel to \$1. We did that for two reasons: First, the comparative economy which we secured by getting a larger number of consumers, if gas was reduced to a price that was unmistakably cheap, rather than to confirm itself by one or two or three years' demonstration, which would only gradually come to the surface. Second: We find in our community, which perhaps has as large an amount of total depravity as you find elsewhere, that the man who burns a large amount of gas in his house at \$1.25, or whatever the rate is, but in his place of business gets it for less money, he wants it as cheap all around. Now the larger consumer, who gets his gas at \$1 per 1000, for instance, but who pays for it in his house at the rate of \$1.25, is very apt to insist on the computation of the amount of gas burned, at the low price. Consequently, you are having continual annoyance, and, in case of competition, decided trouble. Now of course the arrangement that we adopted would require the setting of additional meters; but we increased

our consumption the last year about 30 per cent. on the gas sold. In our community I don't think any other scheme would have been satisfactory. We have secured such a favorable opinion among our consumers that I think this year we will perhaps double our use of gas stoves. I think we have now very nearly 140 gas stoves—perhaps two-thirds of these are gas ranges—and the experience of those who are using gas was so complimentary to the company that a great many now adopt some means of warming their kitchens, using the surplus heat of the hot air furnace for such purpose, thus abandoning their coal stoves the year through. Our winter consumption for fuel is only 25 per cent. less than our summer consumption was last year, for same purpose.

A Member—The day consumption?

Mr. Strong—I mean the day consumption on gas stoves. In other words, we have a number who are throwing away their stoves and depending upon the gas fuel to warm their kitchens by means of hot air or steam. I think the great increase gas companies can make in the amount of gas that is used, is in the direction of day gas, in cases where you have competition, as we have, by incandescent lighting.

Mr. Evans—It strikes me that if the price of gas is made low to large consumers (low per thousand feet) they would still have an inclination to save, whereas, if the price were based on their yearly consumption they would make it a point to reach those figures. For instance, a consumer who has been consuming 500,000 feet a year at \$1.40 per thousand, say, would make that bill aggregate \$700 a year; but if the price were reduced (for 600,000 feet burned) to \$1.30, the bill then would be simply \$780, or he would get the last 100,000 feet for \$80 or 80 cents a thousand. If the price was reduced still lower—for a consumption of 700,000 feet, say \$1.20, he would receive the last 200,000 feet for \$140, or 70 cents a thousand. You can carry that up to a million. For instance, if he used a million feet a year at \$1 a thousand, he will simply be paying \$1,000, and they will get the extra 500,000 feet for \$300, or 60 cents a thousand. These are the figures I have gone into, contemplating making some reduction, as I said before, in the illuminating gas in mains that do not parallel our water gas. It strikes me that the tendency would be for the consumer to use the gas so as to bring the amount up to a point where he would get low rates. He could then illuminate his house or a hotel, whatever it might be, as much as he saw fit. I would simply make them their rebates semi-annually, or at the end of the year, billing their gas at the regular rates and making this discount semi-annually, or, as I said before, at the end of the year.

On motion a vote of thanks was passed to Mr. Faben.

Mr. Faben—I move that the Secretary be instructed to communicate with the Superintendent of the Census, asking that the data on the consumption of gas for uses other than lighting be extensively gone into. I have not the exact wording of the proposed letter. The Secretary can frame that. [Adopted.]

At this point Mr. H. Wilkiemeyer, of Portsmouth, read his paper, entitled:

MUNICIPAL CONTROL OF LIGHTING.

Man was born free. The Creator endowed him with the fullest liberty. He had not lived long until he got into trouble and discovered he needed protection against himself. He was wild and savage, and he knew it. He also knew that he was capable of better things than those into which he was led by his unbridled, unrestrained instincts. He therefore, for the sake of bettering his condition, surrendered certain of his inherent rights and entered into the social compact. He said to his neighbor, "You stop reaping the grain which I have sown, and I will no more feast upon the cattle which you have herded and guarded from the wolves." The ideas of "mine" and "thine" became more firmly fixed. There was compensation in this arrangement for all parties connected therewith. While one party, on his part, was compelled to forego the pleasure of stealing the goods of his neighbor, on the other hand his own chattels were the more secure. By the surrender of certain of his inherent rights, other rights were rendered more stable: greater security, both in purse and person, was realized, and out of these mutual surrenderings Society was formed. Therefore it may be laid down as an axiom that societies, or communities, exercising corporate functions, were formed and exist as a police measure. The *rationale* of the construction of the social fabric precludes the exercise by the municipality of all functions but those that are police in their nature and tendency. Whenever a departure from this rule occurs, then liberty suffers, and another item of natural personal liberty is sucked into the great vortex of centralization of power. It is therefore wrong, on first principles, for a city to engage in any other occupation or business than that for which cities, or communities, or society, was originally established.

The centralization of affairs in the Government is eminently unwise, for there is no limit to the venture. If the city has an inherent and politic right to go into the lighting business, it has also the right to go into the coal, clothing and grocery business. The result would be either absolute anarchy or abject slavery.

Societies should continue to serve the purpose for which they were created. It is dangerous precedent for them to go further or assume more. By absorption of all business, the Government would become paternal in its nature. Ambition would have no place in our make-up, and we would be a nation of nonentities, no man depending upon himself or his neighbor. We would be an army without soldiers, or perhaps we would attain that delight-

fully philosophic, but lamentably impractical, condition described by Bellamy in his recent novel, "Looking Backward."

But the question as to the advisability of a city's owning and operating a gas light or electric light plant, instead of being philosophic and speculative, is pre-eminently an economic and practical one; and the practical phases of it only should be regarded. Enthusiasts and men who have machinery and lighting apparatus to sell to cities (in the absence of a multiplicity of private customers), have at great expense been flooding the popular and scientific prints with long articles from the pens of hired sophists. By their fallacious but plausible arguments many a fair municipality, which was prosperous and peaceful, has been plunged into a state of disquiet, and has had a white elephant imposed upon it in the shape of a gas or electric light plant, which must forever be fed and nourished from the public crib, or which will, when the novelty of the affair wears off and when officers become negligent, be cast aside to be of no future use except as an undying memento of the folly of following the advice of persons interested in the sale to the city.

Of course the smooth-tongued agent presents the matter in a glowing light. It is his business. He has studied the points, and he knows what to push most forcibly and what to pass by as not worthy of mention. It may safely be laid down as an axiom, that whenever a city embarks in a venture that even savors of money-making, it is exceeding either its legal powers or is encroaching upon rights never ceded by the people.

Old adages are good, and as they have stood the test of time they must be true. "What is everybody's business is nobody's business" and "every man to his own trade" are two trite phrases that seem particularly appropriate in the discussion of this question. The managers of a city plant, however honest, have not, and can not have, the same material interest in its economical and successful administration as would an individual owning the same. Expensive experiments are more likely to be made when the cash does not come from the pocket of the experimenter. His salary is secure, no matter upon which side of the ledger the balance stands at the end of the year.

He has the credit of the city at his back, and a few thousands in extravagance will not be remarked by the public.

Looseness and carelessness are almost inevitable in the management of a city lighting plant. On the contrary, when the owners of the plant are its managers, every cent of the expenditures is carefully, jealously scrutinized. Men are employed because they will work, and they must work to their full capacity or seek employment elsewhere. They are not employed and retained in well-paid positions for political reward, but for the work they do. No man can secure an agent who gives the same attention to his affairs as he does himself, nor can a city secure the same service which an individual gives to his own affairs.

It has been argued that a private gas or other lighting company has a monopoly. Granted. But they are entirely different in their nature from mercantile monopolies. Take a private corporation, engaged in the sale of any given commodity. It can, if it has a monopoly in the article, establish a given price, and say to the public, "Either buy from us at our price or go without. We own it all, and you will have to pay what we ask." It is not thus with a lighting company.

Corporations have ever been jealously guarded by the people, and their power and privileges curtailed. Under existing laws, a monopoly in lighting is impossible. The city may fix the price which it will pay for gas for a definite time, and the company must sell at that price if that price be fair. There are so many other ways of lighting than by gas and electricity, that it is impossible for a company dealing in either to be in the least arbitrary.

True, a certain company may be the only one that has gas or electric light for sale in a given locality, but even in such a case it never has a monopoly in the strict sense of the word, or even in the plain business sense of the word. No man nor set of men can control the price of light. If A asks too much for his electricity, I can buy from B, the gas man: If A and B combine and run up the price, I and my neighbors can buy a barrel of coal oil, and while we are burning half of it A and B will come to the conclusion that they have made a grievous business error, and will quickly come to terms.

The people of a city have it in their power to dictate absolute terms to a lighting company. The company has money invested in its plant, and it depends on the people for its income. When the people withdraw their patronage, the income from the investment ceases, and the venture from that moment becomes unproductive. Now, it is plainly within the power of the people to exercise power over lighting companies in more ways than one. The Creator has placed in the bowels of the earth, and within easy reach, oils, by the use of which, for even a day, great loss ensues to a company. The plan and principle of a lighting company is to extend the patronage; this can only be done by keeping the price down.

The adage of an ordinary monopoly is, "Charge the highest price the purchaser can afford to give." The adage of a lighting company is, "Sell at as low a price as you can afford to take, extend your patronage, and run your institution to its limit."

Another restriction of which the public may avail itself, is this: Whenever the citizens discover that an unfair advantage is sought to be taken by the light company, they can, under the laws, call a halt. No private company owning a light plant can afford, by

extortion, to drive the municipality, in which it is located, into a fight, which, in nine cases out of ten, means ruin. The value of the plant is virtually in the hands of the municipal authorities, and they can therefore exercise a summary and wholesome jurisdiction over the lighting company without investing a single dollar of the people's money. The claim, therefore, that a private lighting company is a monopoly, is erroneous. The municipality has arbitrary power, and would not, nor does not, hesitate to exercise the same when circumstances demand it.

It is said that a municipal lighting company can afford to sell at cost. But where the gain? Who supplies the money to pay the cost? Is it those who use gas and electric light? By no means. The men who live in a cottage and the cabin pay taxes. What does it avail them that a man who lives in a mansard can have his halls lighted by electricity at cost? They burn oil or tallow. Cost price is too high to enable them to indulge in electric light, yet they, the men who dwell in the humble houses of labor, the men whose brawn and muscle and brain made this country what it is, must be called upon to help pay for the illumination of the palaces of these princes and potentates of finance. It is unfair. There is no justice in it, and the system which compels them to do it is radically wrong. Let the man who wants an electric light buy it and pay for it if he is able; if not, let him burn gas. If that be too expensive for his pocket, then he should burn oil. If that be beyond his means, let him go to bed and get up aided by the tallow dip of our grand-mothers.

The system of taxing a poor man in order that a rich man may have his luxuries at a lesser cost, will never prevail in a land where justice has an abiding place. But, it may be urged, the owner of the small house must pay his proportion of the taxes, any way, and his taxes are lessened in proportion as the expenditures of the city are high or low; the city must be lighted, and if it is done at a lower cost by reason of the city owning the light plant, he benefits thereby. But the public, it has been estimated, forms only one-sixth of the patronage of a light company. And, therefore, he benefits himself to the extent of one-sixth, while he benefits his wealthy neighbors to the extent of five-sixths.

But is it an invariable fact that a city sells light at cost? Let us see if there are not reasons which lead, naturally, to their selling at a profit. The Superintendent and Directors desire to make as good a public showing as possible. They do not care to have it appear in their stated reports that the business which they have been conducting cost more than it brought in, so they, in order to demonstrate managerial ability, are naturally inclined to put up prices. This is not only true in theory, but in fact. In the city of Portsmouth, Ohio, for example, seven lamps are sold to the county and to the railroads. Each lamp, according to the statement of those in authority, costs less than \$30 per annum. Yet the county and railroads pay per year for each lamp the sum of \$100. Surely, no private corporation would be suffered to do thus, nor would it have the temerity to try, "soulless" though it be.

Capital is crystallized labor. Every dollar is made sacred by hours of labor. Every penny represents a drop of sweat that falls from the laborer's brow. Capital, as well as every expenditure of mind or matter, must bring its compensation. The legitimate purpose of capital is *investment*. The man or the policy which prevents the investment of private wealth in a town or city does a wrong to labor. Yet this is what a city does when it embarks in the business of selling light.

It is urged by some writers, as an argument in favor of municipal ownership of light plants, that the cost of light in cities owning their own plants is so much less, by comparison, than those lighted by private companies. But these writers invariably fail to tell us the tax rate in these cities. Why this omission? Can it be that the force of their argument would be lessened by the publishing of that very important factor? Is it because this important fact would give the lie to the assertion that a saving is made by the city's operating the light plant?

The capital of a city is derived primarily from the pockets of the people; secondarily, from the vaults of the city treasurer. It is not an exercise of solid political economy to allow the people's money to be invested in a commercial undertaking.

No industry is generated unless there is, as an object, a profit. The motive for private capital to invest in a certain line of business is destroyed, annihilated, when a city enters into the same line of business and conducts the business with no desire to make a profit. It is a dangerous principle, and one subversive of all our cherished ideas, that a city may forestall the investment of private capital and assume and arrogate to itself a certain line of business without profit as an object.

No man should be willing to be taxed in order that a city should secure capital with which to strangle private enterprise. If it is good policy to allow a city to embark in and run and manage a light plant, it is also good policy to allow it to own and manage street car lines, telephone service or a meat shop. It receives its capital from taxation. It has no interest to pay except upon the pledged credit of the municipality, nor is it taxed. It can exist forever without making a cent of profit. And when the credit of the city is pledged the citizen is taxed once for the principal and once for the interest. The city, which needs no profit, competes against private enterprise, and so successfully as to deprive it of all hope of a reward. It is driving private capital from one investment to another, because private capital must increase or decrease, while the city is doing all that is requisite when it comes out even.

It does not have to eat or wear clothes. It has no doctor bills or funeral expenses to pay, no school books or taxes or interest to pay, and it can live without making money. It is to the interest of the citizens that cities do not own and operate a light plant.

The President—Gentlemen, we have just listened to, I was going to say, as good a paper as I ever heard read; but I ought not to manufacture capital here for any man's paper. I will say you have listened to a good paper and it ought to be thoroughly discussed. I surely hope it will be.

The Secretary—Mr. President, I would not want to say anything that would block the discussion of Mr. Welkiemeyer's paper at once; but I will mention, as proof of the interest now being taken in this question, we have voluntarily offered to us at this meeting two further papers on this same subject. Before leaving Columbus, yesterday, I was surprised to have handed me a nicely type-written paper entitled "Municipal Control of Gas Works," by a gentleman connected with the Columbus Company. I had invited him to attend and help discuss this question, as I knew it was one in which he would naturally take an interest. He has given economic and social questions a good deal of thought. It is his bent, and his opinions are worthy of consideration. He was unable to attend, but had prepared a paper embodying his views. I read the paper on my way here. I thought it merited presentation in the same form in which the other papers have been presented, and on arriving here I immediately had enough copies printed to distribute one to each member. Furthermore I have a letter from Mr. Foote, of Washington, D. C., which reads:

"Dear Sir:—I expect to leave here Wednesday morning and to arrive in Toledo Thursday morning. Had expected to get off today, but find I cannot do it. I enclose you a copy of a paper I have prepared to be read before the Association. If by any mishap I should fail to be present, will you kindly ask Mr. Graeff, or someone else, to read it for me?
Yours respectfully,
ALLEN R. FOOTE."

The President—Gentlemen, I know nothing more of these papers than you know. You have heard the entire statement. It would appear to me that our interests might possibly be subserved by having the reading of these other papers and discuss this question afterwards. Mr. Wilkiemeyer is with us, and perhaps Mr. Foote may be. He will not be, however, in time for this discussion; yet a motion that should cover this ground would be a quite proper thing to entertain at this time, and I trust if anyone cares to hear from these other papers that he will make a motion that will recognize them.

Mr. Cantine—I move, Mr. President, that the discussion of this paper shall be postponed until those of the Columbus gentleman and Mr. Foote shall be read and then discuss the three, as they all bear upon the same subject. [Adopted.]

Mr. Cantine—Mr. President, during the distribution of these papers I would like to present to you the name of Mr. O. S. Webster as a member of this Association. He is a resident of Michigan, and he has been tried by fire as hot as that required to make gas. He and I suffered and bled for our country in the same regiment. He came down here and offered himself as a sacrifice, and I now introduce to you Mr. Webster.

The President—I have no doubt the Association will be glad to greet Mr. Webster. The blanks upon which his application should be made will be provided by the Secretary, and at the same time there are a number of others whom we desire to welcome to our ranks. I suppose we may defer that a little longer. I will now ask the Secretary to read Mr. Gemunder's paper.

The Secretary then read the following paper, by Mr. M. A. Gemunder, of Columbus, Ohio, which had for its title:

MUNICIPAL CONTROL OF GAS WORKS.

Leaving out of question the points raised by socialists who claim that the true function of government is to take charge of all lines of production, and looking rather at those put forward by individuals who acknowledge or allege that state agency is not equally effective in every department of industry, will at this time be more to the point, as the latter opinion is that which is held by the most numerous antagonists of private interests in the line of gas supply. Many of the most advanced thinkers have long ago given up the idea that the public can best be served by competing companies, and hence term the agencies which furnish such commodities as gas, water or electricity, natural monopolies.

It is further stated that as our commonwealth and national institutions are opposed to privileged classes, that is, guaranteeing some citizens benefits at the expense of others, and as it would be necessary to foster such, if competition were abolished, in order that the best service may ultimately be secured, it follows that expediency, as well as sound statesmanship, would demand that the people as a whole unite in controlling that which should minister equally to the welfare of all.

This seems plausible enough, but unfortunately the community as a whole, that is "all of us," never can operate either a gas, water or electric plant. The public can only work through special agents—that is, through "some of us"—and it is through the short coming of "some of us" that the expectations of "all of us" so frequently lack realization.

The main argument advanced by many advocates of municipal control, such as Professor Ely, of Johns Hopkins University, or

Mr. Keeler, in a recent article in the *Forum*, is an arrangement side by side of prices charged in various cities by public or private works for like services, and which are so selected and grouped as to show off private concerns to the poorest advantage. Now, any one connected with a gas company must know that such comparisons made in this manner are absolutely worthless. It can be readily seen that even greater differences in rates exist among the various individual plants worked exclusively by private capital, and as to public corporations, their own charges are not at all equal. There is no fixed or uniform difference in favor of any particular order of management which would appear thus at a glance. We all know that variation in price is very seldom due to any one particular factor. Admitted that Philadelphia (public) charges less than San Francisco (private), does that prove anything? If this difference would lead to the drawing of an inference, would it not be offset by the fact that Cincinnati and Columbus, both with private institutions, charge considerably less than Philadelphia?

The figure at which the public is supplied is the product of many factors, not only such as the cost of coal and the several crude materials used in distillation, but transportation, location of works, size of cities, number of consumers, width of streets, style of architecture of buildings, habits and general prosperity of people, and a host of minor conditions, many or all of which are peculiar to certain localities and very few common to all. It is not here contended, however, that no system of statistics may give rise to accurate conclusions, but only, that they must be very carefully sifted and examined and then accepted with due caution. Prima facie, as before stated, they are exceedingly treacherous. Discarding as insufficient the statistical method for want of proper data, and reasoning after the manner commonly called "on general principles," let us see if it leads to trustworthy results. Municipalities either do or they do not furnish increased blessings; if they do, then there must be a reason therefor; if they do not, failure must be due to some ascertainable cause. This is the problem:

A comparatively few years ago there was first demonstrated a law, that of the Conservation of Energy, which is of the utmost importance in physical science; it has done more to place that science on a firm basis than probably any other single discovery. This law, as you are probably all aware, asserts that: "The quantity of force which can be brought into action in the whole of nature is unchangeable and can be neither increased nor diminished."* With the full recognition and comprehension of this law, there was a sudden disappearance of all search after perpetual motion and such like phantoms, for it became evident that whatever extra energy appeared to come out of one end of a machine, it was only a question of how long or how well one looked before it would be discovered that it entered at some other end.

The critical spirit thus generated in the domain of physical science is at present also strongly permeating and affecting the manner of thought and examination in Social and Economic Science, also finding outlet in everyday life in the saying that "something out of nothing is not to be had."

All arguments for public ownership when analyzed yield simply the following: Municipalities would offer greater service for the same pay, or the same service for less pay than private organizations. That is, its labor is in some way more productive. More energy leaves the machine—where does that additional energy enter?—whence does it come?—We are certain that it must spring from some source, for Government can no more make something out of nothing than can the least important individual.

Suppose that the Government purchase a coal mine for the purpose of supplying itself with fuel. It will of course be acknowledged that after the purchase the coal will be just as deeply imbedded in the earth as before, the mere fact of the public having become the owner will not of itself raise it even in the slightest degree. Where then must the extra energy be looked for? Undoubtedly in the only remaining source, namely, the brains and muscles of those depleting the mine.

But, after all, as previously seen, these factors are furnished not by some unusually potent entity, but only by "some of us," very much like the "rest of us." Naturally, if these "some of us" are no better than the "rest of us," Government brings no new or unusual forces to bear, and it would be folly to state that its efforts entail superior results. This would surely be getting something out of nothing.

It may be replied, however, that there is a difference among the various individuals comprising "all of us," and if the best are chosen to perform a certain duty, their endeavors must yield the most satisfactory consequences.

This then brings us to a direct comparison between Government officials and private management. Here arise two questions:—

First.—Are the "some of us" chosen to perform certain functions really for the "best of us," for the purpose?

Second.—Are conditions such as to demand from them their utmost?

As to the first question, little attention need be paid. The reputation for ability and morals of the general run of Legislators, office holders and politicians is so well known as to require little comment. It is only in rare instances that they are selected, or, when selected, retained, because of any special fitness displayed. The Civil Service Reform movement of to-day will go far in bearing out this statement.

Mr. Donisthorpe, in a recent economic work, makes the following

*Helmholz.

pointed comment: "The art of Legislation is a very difficult and complicated study; much more so than farming or boot making for example, and yet, as has been remarked with amazement by thinkers of the weight of Socrates, Shakespeare and Spencer, whereas a lifetime is required for the mastery of the humblest handicrafts, almost any ignorant busybody is credited with intuitively understanding that most intricate art, legislation.

"Were I to walk into an engine room and point out to the engineer the intolerable waste of steam entailed by a hole in the boiler, and urge him to stop it, he might turn upon me with some such reply as this: 'Sir, that hole is called the safety-valve; if you would bring your mighty brain power to bear on some subject with which previous study has qualified you to deal without making an ass of yourself, you might be doing more good to the community and less harm to me. Good morning.' And yet this same engineer will walk into the great legislative laboratory where the complex parts of the machinery of state are forged, and with the serenest self-confidence take off his coat and set to work."

That this state of affairs is owing to the nature of things and is likely to remain thus for an indefinite time, is more than probable. The brightest and strongest characters and intellects will of necessity be monopolized in those productive channels which promise the greatest reward to industry, these of course existing largely outside the sphere of government.

An excellent illustration of this tendency was furnished some time ago, when President Cleveland was somewhat taken to task for what was considered unreasonable delay in filling some vacancies that had occurred in a very important commission; the President replied and justified himself by saying that although he knew of many men capable of filling these places, yet the salaries and incomes that their labors in other fields yielded them were so great that the remuneration offered by the Government, generous as it may seem, presented no temptation.

The first question may be dismissed without further discussion, as all are familiar with its bearings. The second is, however, of greater importance.

The testimony of all human experience is that man endeavors to satisfy his wants at the least possible expenditure of his energy, and consequently the greatest exertion is only concomitant with the greatest need of pressure.

Should A desire the performance of a piece of work and be unable to attend to it in person, he would be compelled to delegate B to carry out his plans. Under what restraints would B now consider himself for the performance of his duty? Evidently he would consider himself responsible only for ordinary reasonable care, and if he be honest, his sense of responsibility, together with the fixed amount of his reward, would prevent his taking any but ordinary chances, for fear of exceeding his authority, thus fixing upon himself a certain loss with no direct prospect of possible gain. His action must be conservative and not progressive, hence not in the highest degree productive.

Should, now, B sublet to C, then it must be plain that A's chances of receiving good service will also diminish. The only desire in B and C is not so much the fulfillment of A's plans, as it is to put in honest time, with the risk limitations already specified, at his expense. A, on the contrary, not only risks the loss of his expected benefits, but also the pay of B. The greatest anxiety for success is surely with A, and were conditions favorable so as to allow A to labor in his own behalf, it would not be hard to designate the source of the greatest energy.

The old maxim "if you wish a thing well done, you must do it yourself," has hardly arisen without a foundation in experience. Probably every one has had more or less occasion to appreciate its truth. Its application here is simply this:—

In all private corporations and business concerns, those who control and manage them are either those who directly own them or else stand in close relation to them. They are those who directly pay the penalty of a mistake, be it honest or otherwise, not only by being discredited in the eyes of one's neighbors, but capital earnings and very existence are at stake. It is here that employees are most carefully tested, and possible gains or losses most rigidly compared and weighed. Rewards and penalties being less remotely connected with conduct, cause and effect better apprehended, the greatest scope is given to productive energy and skill.

But how do matters stand in public hands? Here all action is of the delegated kind, and agents are held responsible for their trusts only in a more indirect way, and disaster for misconduct is far lighter and less certain in its effect.

Inducement to extraordinary action is lessened and it may be accepted as a certainty that the more we shift or separate those consequences which naturally follow any line of conduct from such conduct, the poorer will be the outcome.

All will probably remember the State's action in the Scott Law contest. Here legislators passed a law, taxing a certain class of business houses. This tax was in many instances promptly collected. The Supreme Court later declared this law unconstitutional and the collection of the tax unwarranted. Those who had paid the tax to the State expected naturally to be reimbursed, but here the courts again held that this could not be done without committing another wrong. Great loss to honest tax-payers was the result.

But how fared it with those whose ignorance directly caused this distress! Does any one even remember their names? Was the suffering in any way visited on them? Did they not draw their full pay and come up again for re-election the same as ever?

It may be said that they, as fellow-citizens, share public calamities; which would be true in the same way that a man loses by laying down a dime and taking up a dollar.

Would it not be more than probable that if the legislators who passed the act could have been given to understand that they would be held directly accountable for any wrong committed, their actions would have been much more painstaking and deliberate?

The *vicarious nature of all Government action* must always continue to be the cause of inferiority in all State and municipal management. It is and will ever remain the element of weakness that will prevent the raising of any superstructure with State or municipal management as a foundation. This doctrine I hold as of the utmost importance, and were it more generally appreciated, it would often save the community great loss.

Returning now to the mining example, if the coal fails, by reason of state ownership, to be raised nearer the surface, and as we see that the brains and muscles applied for that purpose are of a restricted and inferior kind, then it cannot be maintained that Government management can be the most productive. No extra energy can leave such a machine, for none has entered.

There is yet another argument that deserves consideration. It may be claimed by some, while acknowledging the greater economy in private supervision, that the chief object in municipal control is the prevention of excessive rates, which are the result of undue profits in monopolies; that the community could better stand a waste in production than a greater loss by extortionate charges.

Here again is an oversight. Every municipality, when franchises are granted, has the power to make such stipulations as regards rates, etc., as may be mutually agreeable. If it fails to possess the requisite wisdom and purpose to make this single agreement a good one, on what possible grounds can it be expected to make good the innumerable ones connected with the carrying on of even an ordinary enterprise with any better hope of success?

No city need be at the mercy of any corporation. It can easily secure for its franchise such a rate as will allow only fair returns on investments. Permit this rate to extend over a definite period of time, allowing the corporation the entire benefits resulting from any improvements introduced, this will prevent stagnation in efforts. At the expiration of the allotted time renew the contract at a new rate, which has as a basis the now-improved manner of production.

Private control has another great advantage, namely, it throws the entire cost of production on those who are the consumers and beneficiaries, and does not require any deficit to be made good by those who had no such advantages, which is the case where loss is repaired by general taxation.

Neither is the present generation of tax-payers saddled by any heavy debt, incurred in erecting works, in order that future generations may reap the benefit for nothing. That is to say, every one will pay his own gas bill.

The President—Gentlemen, the paper of Mr. Foote is not printed. A copy is in the hands of Mr. Graeff, and we will be pleased to have him now read it.

Mr. Graeff then read the paper of Mr. Foote.

MUNICIPAL CONTROL OF GAS AND ELECTRIC LIGHTING PLANTS.

That system of political economy is best which enables the poorest member of society to become richer. The breadwinner must have bread now. For this reason, economic systems, promising immediate benefit, quickly become popular with the masses. In political contests present advantages always strive for the mastery, with duty to principle. While an election is pending the wage-worker has many friends. Why? Because, by reason of numbers, his class holds the balance of power. There is always much talk about measures to make this or that thing cheaper, or, in general terms, to make living cheaper. The advocates of cheapness do not explain, and the wage-earner does not think far enough to see, that cheaper living means lower wages. With living and wages both made cheaper the economic condition of the wage-earner remains unchanged.

Civilization has entered upon an era of economic evolution. I say evolution, because progress in the development of an economic system, in accord with the requirements of natural economic law, cannot be induced, except by a condition of general and high degree of intelligence, an intelligence that will not permit the destructions of a revolution. Creeds of churches and codes of secular law have reached the limit of their power to benefit the people without taking into consideration the economic conditions under which they live. He teaches both religion and patriotism who teaches the principles of natural economic laws. The power given by nature to man to produce more than he consumes gives him the power to relieve himself from the law of necessity. It is his natural birthright to freedom. Benjamin Franklin's formula for making money plenty in the pockets of every man is based on natural economic law: "Earn money honestly, spend less than you earn, and save the difference." 'Tis simple, but not easy to do. The first requires strength; the second, courage; the third, intelligence. It is because of the lack of economic intelligence that there is any failure in justice in the distribution of the results of labor. For this reason, questions tending to create popular interest in economic science should be welcomed, not feared.

The new departure in the discussion of labor questions under-

taken by the Emperor of Germany; the recommendation of government ownership for all interstate railroads, by President Blackstone, of the Alton system; the effort to initiate government ownership of telegraphs, by Postmaster-General Wanamaker; the use of crop values as the basis for a national currency, advocated by President Livingstone, of the Farmers' Alliance; the monster petition to bear the signatures of 200,000 persons, asking the Massachusetts legislature to give cities and towns the right to establish their own gas and electric light works, to be presented by the nationalists; the use of land securities as the basis of a national currency, proposed by Senator Stanford of California, together with similar projects by others, make up the moraine of the oncoming economic evolution.

The advocates of municipal control of lighting give but one reason for their policy. It is that it will make the lighting service cheaper. The same argument will serve equally well, a movement for municipal ownership of gas plants; electrical plants; street car lines; ferries and telephone exchanges. More than this, it will suit just as well, a demand for the national ownership of railroads; telegraphs and the express business.

But why stop here? It will apply with still greater force to the national ownership of every productive or distributive industry. If a municipality can perform any service cheaper than it can be done by a private individual, a state can do it cheaper than the municipality, and the nation can do it cheaper than the state. If a single industry can be so handled, then every industry can. The logical sequence of municipal ownership is national ownership. The inevitable result of the control of one industry by government monopoly, will be a government monopoly of all industries. Those who do not wish to see the principal of municipal ownership carried to its logical conclusion, should not advocate it. Those who do not desire the national ownership of all industries, should present a united opposition to municipal ownership of any industry. No dam will ever burst if the first leak appearing, be effectually stopped. No great fire will ever occur, if the first blaze be instantly quenched. No great disaster will ever cause wide-spread destruction or suffering, if its initial cause be judiciously and promptly removed or overcome.

All theories must stand uncovered in the presence of facts. Economic theories are not relegated to the far off future for a demonstration of their correctness. The results of municipal ownership may be proven now. There are a sufficient number of undertakings of that character now in operation to render the demonstration complete. If the claims of those who advocate municipal ownership be true, they can prove them by accounts now being kept. I challenge any municipality in the United States owning a gas or an electric light plant, to submit the question of the policy of municipal ownership to the arbitration of provable facts. That this may be done, attention must first be given to the classification of items and the form of accounts of receipts and disbursements. The greatest difficulty in the way of a proper solution of this question, is the fact that there is no scientific classification of the items of accounts, made with a view of causing them to show all essential economic details, nor is there a close scrutiny to prove their accuracy. The people do not know whether the accounts are properly kept or not. They do not know whether or not, every item that enters into the cost of the plant, its operation and maintenance, is properly charged. Laxity in scrutinizing the methods in which the proceeds of the tax are expended, is a strong objection to indirect taxation. Wherever there is a lapse of vigilance, there is a lapse of virtue. Consider the lamentable failure of the vast majority of men to conform to the requirements of an exact science of economy and accounts, in the management of their private receipts and expenditures, then consider that such imperfectly developed economists are entrusted with the management of the accounts of municipal works, and a fair idea of the difficulties to be met with in this direction, may be formed.

Not one man in one hundred is able to give an exact account of every dollar of his private income and expenses at the end of a year. This is the reason why it is so difficult to carry into practical effect Benjamin Franklin's formula for making money plenty in every man's pocket. The accounts of partnerships are probably more carefully kept than any others. This is because those interested in them are few. They are vitally interested in the results of the business, and as a necessary consequence, give their accounts a most careful scrutiny. The accounts of stock companies are scrutinized much more closely than those of municipalities. The managers of such companies know that they have among their stockholders able critics, whose invested interests will lead them to give their accounts a most rigid examination. The history of the management of stock companies demonstrates the fact that, wherever there is a lapse of vigilance, there is a lapse of virtue. The human nature of managers of municipal works, is not different from, nor better than the human nature of men in the management of their private affairs. If men are not exact and honest with themselves in the management of their own finances how can they be made exact and honest in the management of municipal finances? The only safe-guard for the man and for the municipality, is the regular publication of accounts in approved forms, showing every dollar of income and expense, in items classified in accord with the requirements of a sound economy. The question of honesty is of minor importance in the demand for a scientific system of economic accounting. A system of accounting that will satisfy economic requirements, will satisfy all moral requirements. Morality has no existence apart from the principles of natural economic law.

Money may be spent honestly and not be spent economically. There can be no scientific demonstration of economic results, without a scientific record of economic operations. Upon such data only can economic policies be safely based. Those favoring municipal ownership can afford to wait until such data can be obtained, before committing their municipality to a measure of doubtful expediency, and one that may ultimately prove undesirable.

This demand for scientific investigation of, and basis for, economic action, is in the interest of the poorest member of society. It is in the interest of the whole people without distinction as to their economic condition. It is in the interest of the municipality, of the state, and of the nation. Every economist, every candidate for votes, that favors municipal control of lighting, and who is honest in the opinions he holds, cannot refuse to join those who oppose that policy, in demanding that all accounts be kept in accord with the requirements of a scientific classification of receipts and disbursements, to show all essential economic details. This demand is in the interest of good government and good morals.

I say to the people of all municipalities that have committed themselves to the principle of municipal ownership, you have entered upon an economic policy that will ultimate in industrial slavery. You sought escape from a limited monopoly, and have established an absolute monopoly. You are levying a tax on consumption, instead of possessions. This is the most inequitable form of taxation. Professor Richard T. Ely says, in "Problems of To-day," pages 6, 7, 10 and 11:

"Indirect taxes are chiefly taxes on commodities; in other words, taxes on what we eat and wear and consume in other ways. This is taxation on consumption; but does consumption of taxed commodities vary with income? Indirect taxation does not discriminate between the last dollar of the poor widow, and the dollar which is only one in an income of a million. Indirect taxes are imposed on people without creating so much discontent as direct taxes, and without causing so close a scrutiny of the method in which the proceeds of taxation are expended, because the mass of men do not realize that they pay taxes every time they purchase gas and electricity for lighting, when the municipality owns the plant."

Prof. Ely did not write "Gas or Electricity for Lighting," as given in this quotation. He wrote "Dry Goods or Groceries." I made the substitution, which does not change the principle or meaning of what he was saying, so as to make it more directly applicable to the policy of municipal ownership which, strange to say, he advocates. When the municipality owns the plant, the wage earner and the millionaire pay exactly the same rate for the gas they consume. The profit on that gas compels the wage earner to pay a tax a thousand times greater in proportion to his income, than the tax that is paid by the millionaire.

The policy of municipal ownership of lighting-plants can be successfully combated upon practical lines. Let the whole truth be known regarding the accounts of such plants, let the people become thoroughly educated as to the workings and tendency of such undertakings, and, speaking of one of them as representing the whole, the sale of the Philadelphia gas plant to private ownership and management, will become a political necessity.

Discussion.

The President—Gentlemen, that concludes the three papers upon this subject. I think it rarely falls to the lot of an Association to have more valuable subject matter presented than is contained in these three papers. I see only one possible misfortune in it, and that is that they are nearly in the same line. I trust a discussion will develop here that will bring out the full merits of what has been presented. The papers are at your disposal.

Mr. Cantine—Mr. President, I see only one trouble about the matter, and that is there is no one present who would take the affirmative. A great many people in this country have not anything and I would not like to have any person else have anything. They would like to divide up. They would like to be in the year 2000, and "look backward;" but, nevertheless, they would not keep their credit cards 30 days! Eleven months in the year they would starve. Now if any person thinks that municipal ownership of a gas plant is a good thing it would of course also be a good thing for the municipality to own everything else, and we would very soon come to the condition that Egypt is in, where the Khedive owns everything. He builds the railroads, runs the hotels and steamships, and everything else. Nobody owns anything. He has as many wives as he wants, whereas the poor man is satisfied with one poor little wench. Whenever the Khedive wants anything built, he builds it as Solomon built his temple. He pays no wages; there is not even a chance to get a little of the common stock of the concern, which is generally worth nothing! The individual detailed to work upon a railroad, canal, or hotel, or what not, has no prospect whatever. His poor wife brings him his scanty sustenance. She tills the ground and raises his living. If the people of the United States want to get into that condition they should start in and have the Government run everything, and thus remove all the opportunities of making a livelihood and reduce to a vassalage nine-tenths of the human family.

Mr. Wilkiemeyer—Mr. Cantine says this is a one-sided affair. Granted; yet it is an *affair* talked of, and also introduced in a number of places, and the agitation of this question will most likely give us many sleepless nights. Now then, let us seek the first cause of this affair. I will challenge you all to cite me a single case in the State of Ohio where the city controls a gas works or an

electric light plant in opposition to an already established plant, where the gas company was not prime mover by its unfair treatment, injudicious action, etc., all leading to those baneful and most distasteful words—"you *must*" being hurled at the people, and the people resenting in this manner.

The President—I hope the entire party won't take up the gauntlet at once!—(Laughter.)

The Secretary—Mr. Graeff must be familiar with this question; and I should think for the information of some of us, myself included, I would like to ask Mr. Graeff to give us, in brief, the arguments of those who favor municipal control; and, furthermore, if there has been some activity in this direction over the country—"if there's a cloud as big as a man's hand in the horizon, that may grow into something formidable"—I would like to know definitely what danger threatens us in this direction.

Mr. Graeff—Mr. President, I think I am very poorly equipped to answer that question. I think Mr. Wilkiemeyer has given a fair outline of the argument in this paper of his; but, as I see it, the argument is a very short one. It is simply the one against monopoly. A municipality can furnish gas cheaper than a private corporation can, for the reasons that Mr. Wilkiemeyer gives in his paper. Of course the municipality all the time has nobody to consult except the politicians who run it. I believe that is about the argument of the other side. But as regards this cloud the size of a man's hand, I am one of those who recollect that there was a time when that story first begins, when the cloud was not seen at all. Then, at the next observation, the cloud began to appear, and finally there came such a storm as startled those in that part of the country. I think this question of municipal control is growing at a rate at which I think Mr. Wilkiemeyer—and I think he has looked into it as much as any of us—does not appreciate. As he states, it is being agitated and pressed by those who have anything to sell to a municipality. I would like to see a full and fair discussion of this subject. I don't believe there is any question to-day that can be presented that is more important, not even the question of fuel gas; and with this question goes that other of legislative action in regard to gas companies. On that I trust we will hear something to-morrow. I would certainly like to see the discussion of this very full and free. I don't exactly agree with Mr. Wilkiemeyer on one point. He says the poor man pays for the gas burned by the rich man; that the man who lives in a cottage and burns oil when the municipality owns the plant, pays for the gas that the man who lives in the mansion burns. Well, now, my experience in Philadelphia is that the man who burns gas and pays his gas bills, pays for the street lighting of the man who burns oil. Philadelphia sells gas at \$1.50 and the city uses all the gas it chooses to consume for street lighting and other purposes. Therefore, instead of the man who burns oil paying for the lighting of the man who burns gas, in this case the man who burns gas is paying for the street lighting of the man who burns oil, which I think is fully as unsound as the ground on the other side which Mr. Wilkiemeyer takes.

Mr. Wilkiemeyer—Is not that an exceptional case?

Mr. Graeff—I hope it is.

Mr. Wilkiemeyer—If a private company had the plant in Philadelphia, what would it furnish gas at—\$1.50?

Mr. Graeff—I am not quite big enough a gas man to place myself on record, but I think no gas man who understands the condition of things in Philadelphia would say that we would not have gas at \$1.00 per thousand, if a private corporation owned that plant; but the city might then have to pay for its gas.

A Member—I don't think you understand Mr. Wilkiemeyer on that point. Where does Philadelphia get the capital to invest in that plant?

Mr. Graeff—The capital, of course, was raised, in the first place, by loans, which loans have been paid off from the profits on the plant.

A Member—How do they pay them off, with taxes gathered from the poor as well as the rich?

Mr. Graeff—They pay them from the profits resulting from the sale of gas. The works earn the money and pay off their own loans.

Mr. Cantine—Mr. President, not wishing to occupy much of the time, I happen to think of a case that is germane to this subject. I know a town about 20 miles from where I live that owns its own water works. In the town in which I live a New York corporation owns the water works. We pay, I think, \$6.00 a year for domestic purposes. In the other town I think they pay \$3.00. The people are very much better pleased, I think, in the town where the town owns the works. That is the non-taxpayers are. Those who use the water are much better pleased with the \$3.00 rate than those who pay \$6.00, but there is a *deficiency*, and the tax-payers are very much displeased for this \$3.00 rate. Now, there seems to be just about where the trouble all comes in. The tax-payer is very well satisfied with the gas works at their present prices. This I think has effected, probably, as much as anything else, the putting of the price down to where it is. Gas is sold in this country as cheap as it ought to be, considering the facilities for making it, etc. It is an open question whether the general public are better served under a municipal control than privately. I think not. In the former case all the ward heelers are employed as hangers-on, without caring to do any good for the corporation. It requires an immense amount of inspection in all these municipal plants at certain seasons of the year. It takes a great many men to inspect a few street lamps. Ten or 15 would be a good day's work for a man to go over, and see whether the lamps are properly cleaned. After

election is over, they don't get any more inspection for a while. Philadelphia used to require from \$800,000 to \$1,000,000 a year appropriated by the Council to meet deficiencies. Now I don't know at what particular time they commenced to pay this debt that Mr. Graeff speaks of, but that state of affairs was, I think, true eight or ten years ago.

Mr. Graeff—Mr. President, I think all the appropriations made by the city of Philadelphia for its gas works were made in the shape of loans, and I think the last of these loans has recently matured and been paid off, or there may be one still remaining. But as I understand it, all the money advanced was in the shape of loans to the Trustees of the work. I think that is correct.

Mr. Tayler—Mr. Chairman, Mr. Wilkiemeyer says he challenges any one to show any gas company in the State of Ohio that has not brought on its own troubles. I don't believe he is right. I am not speaking with reference to any particular plants, but on general principles. I think the facts are that the older companies, at least a great majority of them, did not provide against this in the way they ought to have done in earlier days; and, speaking generally, I think gas companies are to blame for the trouble they are *now* experiencing, but I don't think Mr. Wilkiemeyer's criticism applies to a new company that has started in, say, of later years, and has found the citizens already opposed to gas companies (simply because citizens are opposed to them all over the country) and found city councils ready to take all the advantages they can of them, simply because it has been done so before in other places, and in fact because it has become the general complaint all over the country. But I have no doubt that a great many gas companies are experiencing trouble of that kind who in fact are not to blame at all, and who have treated the community fairly.

Mr. Cantine—Mr. President, we don't need to own up that we have done anything wrong. I deny the soft impeachment that we have done wrong. We have not done anything of the sort. Simply because we, as corporations, have paid our debts, treated our men well, paid our taxes, never on the delinquent list, never any executions, never any companies went into liquidation, never made any assignments or re-organized under an order of any court and scaled our debts down and paid our debts off in stock that is worthless, but because we have simply walked up like gentlemen and paid our bills, and done what was right, we have incurred the enmity and hostility of that mean, contemptible spirit that this country is full of. That is all that is wrong. (Applause.)

Mr. Wilkiemeyer—Why do you pay your taxes?

Mr. Cantine—Because I am compelled to.

Mr. Wilkiemeyer—Why are the gas companies reducing their gas rates?

Mr. Cantine—Competition.

Mr. Wilkiemeyer—Competition! Because they have to?

Mr. Cantine—Yes, sir.

Mr. Wilkiemeyer—Now, then, suppose the gas companies, before the electric light people compelled them to come right down to business and go to work, and not sit in the office for customers to come around, but go around and bring them up, had done that before the electric light came in, how much of an advantage would the gas companies have over the electric light companies to-day?

Mr. Cantine—Not a bit. I sold gas, when I had an opportunity to, at 50 per cent. profit. I was not good enough to sell gas at cost and lower. I made hay while the sun shone. I made money out of it, and I don't deny it. I would do it over again. If I started in the gas business to-day, and could get \$3 or \$5 I would take it, and I wouldn't go around soliciting either, not a bit, unless I had to. Competition compels people to do lots of things they don't like to. I am here to tell you the truth. The chief reason that we sell gas for \$1.25 in our town to-day is simply because we have to; and we are on the upper side. We are not the under dog at all. We once sold gas for \$5, and we got that rate then just as easily as we get \$1.25 to-day. The thing amounts to just this, that we don't know so much about other business oftentimes as we do our own—that is a common thing, and we ought not—but I have been engaged in other lines of business, and I know, taking all the commercial businesses of the country, that there has been a gradual—well, I may almost say there had been a rapid scaling down of profits. Take the money that you have in your Portsmouth works, let somebody pay you cash for them, and you will lay awake at nights to consider what to do with your money. You can't put it in banking because you have to do a credit business. You don't dare to put it in merchandise, because they sell too many things at less than cost to realize a profit. Once we didn't have to do that. We sold women's blue calico dresses at 50 per cent. profit. You can buy the same at 20 or 25 per cent. less now, but the price wasn't lowered until it had to be. That is all wrong, you say. There is not very much in the way of business now that is right, and as we are a sort of bright and shining mark the public are shooting their little arrows and shafts and darts at us continually; but they don't puncture many of us, nevertheless. The only fear I have of the gas interests of this State is that they will swamp us with taxes. I think from the account of the meeting of the State assessors in Columbus, that they intend all of the property shall be appraised at its full value. You will find there will never be any diminution of the rate per cent. You had a very able paper on that once, Mr. Wilkiemeyer. Nearly all the cities and towns are taxed 2½ per cent.—26, 27, and even 30 mills on the dollar. You will get a worse black eye there than you have on the price of your gas. I move you, Mr. President, that the thanks of this Association be tendered to the authors of the three papers last read. [Adopted.]

Prices of Arc and Incandescent Electric Light

City.	Name of Company.	City own or operate plant.	No. Arc public St. lamps.	Price per year paid by city public arc St. lamps.	C. P. public arc St. lamps	Public arc lamps burn on the moon-light schedule all night.	Public arc lamps burn to midnight only.	System of arc lights
Ada	Ada Electric Light Co	No	25	\$75	2,000	1 am		Silvey
Ashtabula	The Ashtabula Water Supply Co	No	26	60	2,000	12 moon		American
*Alliance	Mntnal Electric Light Co	No	43	72	2,000	12 6 mo, 20 nights Bal		West. E
Athens	Athens Gas Light & Electric Co	No	32	80	1,200		Yes	T H
Akron	Akron Electric Co	No	180	3 7-10 cts. per h.	2,000	2 am		T H
*Bucyrus	Bucyrus Electric Light Co	No	60	100	2,000	Yes		West. E
Bellaire	Bellaire Gas & Electric Light Co	No	46	90	2,000	Yes		T H
Columbus	Columbus Edison Electric Light Co	No						
Canton	Canton Electric Light & Power Co	No	32	108	2,000	Yes		Schnyler
Conneaut	Conneaut Electric Light Co	No						
*Coshocton	Coshocton Light, Fuel & Power Co	No	45	77 33	2,000	1 am		Jenney
East Liverpool	East Liverpool Western Electric Co	No	36	95	2,000	Yes		West. E
Eaton	Cook & Aydedott	No	Tower 8. 0	150, 100	2,000		Yes	Jenney
Findlay	Findlay Electric Light & Power Co	No	125	60	2,000	Yes		T H
Fremont	Fremont Electric Light & Power Co	No	70	90	2,000	Yes		T H
Fostoria	Fostoria Light & Power Co	No	40	75	2,000		Yes	Brush
*Hillshoro	Hillshoro Gas & Electric Light Co	No	62	70	2,000	Yes		T H
*Hamilton	Hamilton Electric Light Co	No						T H
Hicksville	Hicksville Electric Light Co	No	6	65	1,500		Yes	Schnyler
Kent	Kent Water & Light Co	No	40	60	2,000	2 am		Waterhouse
Lima	Lima Electric Light & Power Co	No	135	88	2,000	Yes		T H
Lehanon	Lehanon Light, Fuel & Power Co	No						
Lancaster	Lancaster Electric Illuminating Co	No	7	90	2,000		Yes	West. E
Marion	Marion Electric Light & Power Co	No	67	72	2,000	18 nights 3 am		Schnyler
Massillon	Massillon Electric Light Co	No	90	70	2,000	6 mo to 1 am, 6 to 2 am		Schnyler
Marysville	Marysville Electric Light & Power Co	No						
Mt. Vernon	Mt. Vernon Ohio Electric Light Co	No	93	78	1,200	Yes		Schnyler
Marietta	Marietta	Yes	68	50 Est	2,000		Yes	Jenney
*Mansfield	Mansfield Electric Light & Power Co	No	82	75	2,000		Yes	West. E
Mansfield	Richland Electric Light & Power Co	No						
Middletown	Middletown Gas Co	No	45	80	1,200	Yes		Sperry
Norwalk	Norwalk Light & Power Co	No	82	70	2,000		Yes	West. E
Napoleon	Beard Electric Light Co	No	16	125 for 12, 100 for 4	2,000	3 am		Beard
New Lisbon	New Lisbon Gas Co	No	27	80	2,000	1 am and 5.30 am		Brush
New Philadelphia	New Philadelphia and Canal Dover	No	NP31 CD 35	72	2,000	1 am		T H
Oxford	Oxford	Yes	36		2,000	Yes		Waterhouse
Portsmouth	Portsmouth	Yes	96	Don't know.	1,200	Moonlight		T H
Painesville	City of Painesville Electric Light Co	Yes	68		2,000	2 am		West. E
Pomeroy	The Pomeroy & Middleport Electric Co	No	25	96	2,000	Yes		T H
Piqua	Piqua Light & P. Co. & Edison E. M. Co.	No	10	100	2,000	Yes		T H
Ravenna	Ravenna Gas & Electric Light Co	No	50	75	2,000	Extra pay		T H
Stuebenville	Stuebenville Gas & Electric Co	No	23	75	2,000	Yes		West. E
*Salem	Salem Electric Light Co	No	11	70	1,200	Yes		Waterhouse
Tiffin	Tiffin Edison Illuminating Co	No						
*Tiffin	Tiffin Electric Light Co	No	116	88	2,000	Yes		West. E
*Toledo	Western Electric Light & Power Co	No	250	100	2,000	Yes		West. E
Toledo	Toledo Electric Co	No	250	100	2,000	Yes		T H
Van Wert	Citizens Electric Light & Power Co	No	53	84	2,000	Yes		T H
Wellsville	Citizens Electric Light & Power Co	No	40	70	2,000		Yes	Waterhouse
Wooster	Wooster Schnyler Electric Light Co	No	69	70	2,000		Yes	Schnyler
Washington C. H.	Washington Electric Light, Heat & P. Co.	No	51	80	1,200		Yes	T H
Youngstown	Mahoning Electric Light Co	No	184	70	2,000	Yes		T H
Zanesville	Zanesville Electric Light Co	No	150	87 50	2,000	12 pm moon after		West. E

I N

*Crawfordsville	Crawfordsville Gas & Electric Light Co	No	73	71 43	1,200	3 am		T H
*Columbus	Citizens Electric Light Co	No	48	52 12½	2,000		Yes	T H
*Evansville	Evansville Gas & Electric Light Co	No	169	120	2,000	Yes		Bush
Fort Wayne	Jenney Electric Light & Power Co	No	146	129	2,000	Yes		Jenney
Frankfort	Citizens Electric Light Co	No	40	68			Yes	T H & A
Goshen	Goshen Electric Light & Power Co	Yes	27	Don't know.	2,000	Yes		West. E
Kokomo	Kokomo Electric Light Co	No	50	100	2,000	Yes		T H
Logansport	Jenney Electric Light & Power Co	No	76	100	2,000	Yes		Jenney
Lafayette	Brush Electric Light Co	No	223	50 40	1,200		Yes	T H
*Lafayette	Lafayette Gas Light Co	No						
*New Albany	New Albany Gas Light & Coke Co	No						American
South Bend	South Bend Electric Co	No	100	100	2,000	Yes, 40		West. E
Terre Haute	Terre Haute Electric Light & Power Co	No	235	70	2,000		Yes	T H
*Valparaiso	Valparaiso Gas & Electric Light Co	No	40	67 50	2,000		Yes	West. E
Vincennes	Vincennes Electric Light & Power Co	No	5	96			Yes	T H
Wabash	Wabash Electric Light Co	No	12	75	2,000		Yes	T H

* Operate Gas Plants.

Prices Charged for Gas in 62 Cities of Ohio and Indiana, February 15, 1890.

O H I O .

City.	Name of Company.	Price to private consumers for illuminating gas per 1,000 cubic feet.	Price to private consumers for Gas used by Stoves and Engines.	No. of public St. lamps.	Price per year per post public St. lamps.	Size burners used in pub. st. lps.	Time of Burning of Public Lamps.	No. hrs. public st. lamps burn per annum.	Maintenance and Care of Lamps paid by.	City own or operate Gas Plant.	City or Co. own lamps and posts.	Date of City Contract.	Population.	Capital paid in.	Process of Manufacture.
Ashtabula	Ashtabula Gas Light Co	\$2 00 15 per cent. - 15 days	\$2 00 15 per cent. 15 days.												
*Alliance	Alliance Gas Light Co	1 25	1 25	None						No	City		8,000	\$60,000	
Bellaire	Bellaire Gas & Electric Co	1 20	1 20	None	\$15	4 Feet	Phila schedule		City	No	City		8,000	40,000	Springer Water Gas
*Bryant	Bryant Gas Light & Fuel Co	2 00	2 00 20 per cent	None						No	City		10,000	60,000	Coal
*Coshacton	Coshacton Light, Fuel & Power Co	2 00 15 per cent	1 50 net	None	\$2 per 1,000.		11:30 pm		City Light and Ext	No	City	Dec. '80, two years.			Springer Water Gas
Columbus	Columbus Gas Light & Coke Co	1 25 20 per cent. 8 days	1 25 20 per cent. 8 days	None						No	City own posts		4,000	40,000	Coal
Canton	Canton Gas Light & Coke Co.	1 35 dis. 5, 10, 15 and 20 per cent.	1 20, 1 15, 1 10 net	450	\$15.	6½ Feet.	All night	2,800	Gas Co.	No	City	No Contract	100,000	720,000	Coal
Dayton	Dayton Gas Light & Coke Co	1 25 10 per cent. 3 days, 1 15 net	1 25 10 per cent. 5 days net 1 15	1,335	\$19.	4 Feet.	All and every light	3,074	City	No	City	April, '88, two years.	25,000	25,000	Coal
Defiance	Defiance Gas Co	10 00 dis. up to 80 per cent	None.	None						No	City	March, '88, ten years	55,000	600,000	Coal and Water Gas
Delaware	Delaware Gas Light & Coal Oil Co	1 75.	1 50.	260	\$12 midnight \$18 3 a. m. \$22 all night \$11 midnight	6 Feet.	{ Part to midnight, part to 3 am sched { 4 and 6 ft. { 74 to midnight, 12 all night		Gas Co.	No	City	Dec. '88, five years.	10,000	80,000	Coal
Elyria	Elyria Gas & Water Co	2 20, 1 80, 1 60 dis. 20 per cent	1 45 dis. 20 per cent	86.		4 and 6 ft.		{ 74 lamps \$14 50 each. { 12 lamps 43 20 each.	City \$34 per Mo	No	City	Mutual	6,000	75,000	Low Water Gas
Gallipolis	Gallipolis Gas & Coke Co.	2 00, 2 25, 2 50 and 3 00.	1 50	104	\$2 per 1,000.	3 Feet.	11 pm	2,400	City	No	City	Yearly	5,000	31,450	Coal
Greenville	Greenville Gas Co.	2 00.	2 00	127	\$25	5 Feet.	All night schedule		City repairs.	No	City	1888, seven years.	4,000	50,000	Coal
Galion	Galion Gas Light Co.	1 50.	1 00	84.	\$15.	5 Feet.	Midnight schedule		Gas Co.	No	City	None now	8,000	61,000	Coal
*Hamilton	Hamilton Gas Light and Coke Co	2 00.	1 50	None						No	City	City bldg. own works.	18,000	35,000	Coal
*Hillsboro	Hillsboro Gas & Electric Light Co	1 50.	1 50	None						No	City	Nov. '88, five years	4,000	20,000	Coal
Kenton	Scioto Natural Gas & Oil Co	1 50.	1 50	173	{ \$123 at \$20, 50 { at \$12.	6 Feet.	All night schedule		Gas Co.	No	City	1880, ten years	6,000	100,000	McKay Water Gas
Lancaster	Lancaster Gas Light & Coke Co	1 50.	1 50	72.	\$16.	5 Feet.	Phila schedule		City	No	City	Yearly	3,000	50,000	Coal
Lima	Lima Gas Light Co.	1 80 dis. 1 50.	None	None						No	City	Expired	18,000	20,000	Springer
Massillon	Massillon Gas Co	1 50 dis. 10 days 1 25	1 25 dis. 10 days 1 00.	42	\$13.	5 Feet.	Midnight to daylight		Gas Co.	No	Company	Oct. '80, nine months	20,000	80,000	McKay Water Gas
*Mansfield	Mansfield Gas Light Co	1 50 dis. 10 days 1 25	1 25 dis. 10 days 1 00.	42	\$13.	5 Feet.	Midnight to daylight		Gas Co.	No	Company	Oct. '80, nine months	20,000	80,000	McKay Water Gas
Mt. Vernon	Mt. Vernon Gas Light & Coke Co	2 50, 2 00, 1 50	Above 1,000 ft. 50 cts.	None						No	City		6,500	100,000	Coal and Oil and Nat. Gas.
Marion	Marion Gas Light Co.	1 50 10 per cent. on 5,000 ft	1 35.	None						No	City		8,000	37,500	Coal
Marietta	Marietta Gas Works	1 25 to 1 80.	1 00.	None						No	City		9,000	25,000	McKay Water Gas
Middletown	Middletown Gas Co	1 50 25 cts. dis. on 10,000 and 50 cts. dis. above 10,000	1 50 2 to 5 000 10 per cent. dis. all over 5,000 1 00.	None						No	City		8,000	70,000	Coal
New Philadelphia	New Philadelphia Gas Light Co	1 75 25 dis. 10 days	1 75 25 dis. 10 days.	78	\$16.	4 Feet.	Moonlight schedule		City	No	City	Dec. '86, five years	5,000	30,000	Coal
*Newark	Newark Gas Light & Coke Co	2 25 with dis. from 25 to 1 00	1 00	190	\$13	4 and 5 ft.	12 o'clock schedule		City	No	City	May, '87	18,000	62,200	Coal
Oberlin	Oberlin Gas & Electric Co	1 75, 2 00, 2 25 net.	1 50	37	\$15	6 Feet.	10 pm 17 nights.		Gas Co	No	City	Expired Jan. '90	20,000	20,000	Coal
Piqua	Piqua Gas Light & Coke Co.	1 50 with dis. 10, 20, 50 cts.	1 50 with dis. 10, 20, 50 cts.	None						No	City		10,000	50,000	Coal and Oil and Nat. Gas.
Portsmouth	Portsmouth Gas & Electric Co.	1 50, 1 75	1 50	None						No	City		15,000	100,000	Coal
Ravenna	Ravenna Gas & Electric Light Co.	1 50.	1 50	None						No	City	Have none	4,000	37,200	Coal
*Salem	Salem Gas Light Co.	1 50.	1 50	None						No	City		6,000	10,000	Coal
Springfield	Springfield Gas Light & Coke Co	1 50.	1 50	134	\$30	4 Feet.	All night	4,000	City pays repairs.	No	City	Nov. '86, five years	40,500	300,000	Coal
*Sidney	Sidney Gas Light & Coke Co.	1 65 dis. 10 days 1 50.	1 65 dis. 10 days 1 50.	134	\$20	5 Feet.	All night Phila schedule.	2,125	Gas Co.	No	City	July, '89, two years	6,000	30,000	Coal
Stenbenville	Stenbenville Gas & Electric Co	1 50, 1 35, 1 22 dis. 10 per cent. 15 days.	1 50, 1 35, 1 22 dis. 10 per cent.	300	\$20	6 Feet.	All night	3,200	City pays \$600 per year	No	City	Aug. '84, five years	18,000	300,000	Coal
*Tiffin	Tiffin Gas Light Co.	1 50.	1 50	None						No	City		42,000	McKay Water Gas	
*Toledo	Toledo Gas Light & Coke Co.	1 35 dis. 10 days 1 25	Engine 1 13.	None						No	City		100,000	700,000	Coal and Water Gas
Wooster	Wooster Gas Light Co	2 00, 1 50.	1 50	None						No	Company	Jan. '80, two years	7,000	90,000	Coal
Warren	Warren Gas Light Co	1 80.	1 80	95.	22 50.	7 Feet.	12 pm Phila schedule.		Gas Co.	No	City	Yearly	7,000	60,000	Coal
*Youngstown	Youngstown Gas Co.	1 50, 1 40, 1 30, 1 20 and 1 00	1 25 5 per cent. dis. small, 10 per cent. dis large	None						No	City			300,000	Coal
Zanesville	Zanesville Gas Light Co.	1 25 5 per cent. and 10 per cent. dis.	1 25 5 per cent. dis. small, 10 per cent. dis large	116.	1 25 per 1,000.	5 Feet.	12 pm after that on Phila schedule.		City	No	City	Mutual	25,000	50,000	Coal

I N D I A N A .

*Crawfordsville	Crawfordsville Gas & Electric Light Co	\$2 net	1 50 net	None						No	City	Yearly	10,000	\$100,000	Coal
*Columbus	Columbus Gas Light & Coke Co	\$2 net	\$2	None						No	City		8,000	50,000	Coal
Elkhart	Elkhart Gas Light & Coke Co	\$2 to 1 50 net	1 50 net	155.	\$20, 12 50.	5 and 6	Philadelphia schedule	{ 34 Lamps, 2,000. { 121 Lamps, 1,000.	City	No	City	Sept. '82, ten years	14,000	50,000	Springer Water Gas
*Evansville	Evansville Gas & Electric Light Co	1 50	Stoves 1 50, Eng. \$1	None.						No	City		50,000	60,000	Coal
Fort Wayne	Fort Wayne Gas Light Co	1 50 net	1 40 net	None.	10 40	5 and 6	12 pm		Gas Co.	No	City	Aug. '84, five years	30,000	225,000	Coal
Frankfort	Frankfort American Gas L. & Coke Co	1 50 net	1 40 net	126.	\$20.	4 Feet.	Phila sched.	2,200	Gas Co.	No	City	1885, five years	8,000	50,000	Coal
*Greensburg	Greensburg Gas Light Co.	2 50 and \$2	\$2.	None						No	City	1868, three years	5,000	48,000	Low
Goshen	Goshen Gas Light Co	1 25.	\$1.	None						No	City		7,000	27,000	Pratt & Ryan Water Gas
Indianapolis	Indianapolis Gas Light & Coke Co	1 25.	1 25.	2,330.	\$15.	4 Feet.	City sched.	2,740	3 55 per Lamp Co.	No	Property owner.	July, '84, still in force.	125,000	350,000	Coal
Jeffersonville	Jeffersonville Gas Co.	\$2 dis. 10 per cent	\$1 net	None	\$20.	5 Feet.	All night.	3,300	City	No	City		12,000	28,475	Coal
*Lafayette	Lafayette Gas Light Co.	1 40, 1 50, 1 60, 1 70	1 40	18.	\$20.	5 Feet.	All night.	3,300	City	No	City		18,000	24,000	Coal
Logansport	Logansport Gas Light & Coke Co	1 20 net	1 20 net	223.	\$20.	4 Feet.	Not in use			No	City		18,000	40,000	Coal
La Porte	La Porte Gas & Coke Co.	\$2 dis. 5 per cent.	\$2 dis. 5 per cent	95.	16 25.	4 Feet.	11 pm 15 night in mos.	1,000	\$4 80 per year Co.	No	City		10,000	50,000	Coal
Michigan City	Michigan City Gas Co.	\$2, 1 80, 1 70, 1 60, 1 50 net	1 50.	None						No	City		12,000	40,000	Coal
Madison	Madison Gas Light Co	\$2 and 2 25	1 50.	None						No	City		10,000	75,000	Coal
*New Albany	New Albany Gas Light & Coke Co	\$2, 1 75, 1 50 net.	1 50 net	538.	\$18.	5 Feet.	Phila. sched.		Gas Co.	No	City	March, '88, 23 years	30,000	100,000	Coal
South Bend	South Bend Gas Light Co	2 50, with 10, 20 and 20 and 10 per cent. dis.	2 50 with 10, 20 and 20 and 10 per cent. dis.	None						No	City		25,000	40,000	Springer Water Gas
Terre Haute	Terre Haute Gas Light Co	1 50.	1 50	None						No	City		40,000	200,000	Coal and Water Gas
Vincennes	Citizens Gas Light Co	1 45, 1 70 net	1 45, 1 70 net	232.	\$36.	5 Feet.	American Meter Co. sched	2,200	City	No	City	Dec. '75, 25 years	12,000	50,000	Coal
*Valparaiso	Valparaiso Gas & Electric Light Co.	1 50, 1 75.	1 50.	None						No	City		7,000	50,000	Patton's Oil Process
Wabash	Wabash Gas Works.	3 70.	\$3	None.						No	City		8,000	10,000	Naphtha

* Operate Electric Light Systems.

Lighting in 69 Cities of Ohio and Indiana, February 15, 1890.

OHIO.

No. of Commercial Arc Lamps	Price per month for commercial arc lamps.	No. of Incandescent st. lps.	Price per yr. paid by city pub. Incandes't st. lamps.	C. P. incandescent St. lamps.	No. of incandescent commercial lamps.	Price per month incandescent commercial lamps.	Use Meter?	System.	Date of city contract.	Natural Gas. as Fuel.	Population.	Capital Paid in.
20	\$7 for 1, \$6 2 or more.				550	16 c p 80c, 50 c p \$2, 100 c p \$3.	No	Silvey.	Jan. '89 5 years	Oil.	2,500	10,000
63	10 50								With water works	Coal.	10,000	200,000
4	\$7								3 years	Coal.	8,000	38,000
23	\$7 to 10 pm, \$8 to 12 pm.								Oct. '89, 3 years	Slack.	3,500	36,000
9	\$8 to 12 pm.								Aug. '89, 1 year.	Coal.	30,000	100,000
185	From \$5 to \$9				9,100	16 c p	Yes	Edison.	Dec. '89, 2 years	Oil	7,000	66,000
28	Average 5 82	10	\$18 per yr.	32	1,500	16 c p 1 cent per hour.	Yes	Edison, 3 Wire		Coal	100,000	200,000
32	Average \$6 to 10 pm.				275	20 c p from \$1 to 62½c.	Yes			Slack.	25,000	100,000
13	\$5 to 10 pm.				150	16 c p \$5.	No		Dec. '89, 5 years.	Coal	3,500	10,000
110	\$6.				200	32 c p \$1.	No		Feb. '89, 3 years.	Natural Gas.	12,000	22,000
60	5 50 to 10 pm, 6 50 to 2 am.				500	16 c p 60c	No	T. & H. altern'g	Dec. '86, 5 years.	Coal and Oil.	4,000	17,000
25	7 50.						No		July '88, 5 years.	Natural Gas.	20,000	Not Incorp.
26	\$8 to 12 pm.						No		Jan. '90, 5 years	Natural Gas.	12,000	60,000
27	\$6 to 10 pm, \$9 to 12 pm.				90	16 c p \$1.	No		Natural Gas.	Natural Gas.	8,000	8,000
1	6 25.						No		Nov. '88, 5 years.	Coal.	4,000	50,000
70	\$10				507	16 c p \$1.	Yes	Westinghouse	June '89, 3 years.	Wood and Coal	18,000	50,000
40	7 50 to 12 pm, 6 25 to 10 pm				1,500	{ 16 c p 76c 25 c p 1 12½ 50 c p 2 25.	Yes	Westinghouse	Jan. '89, 5 years.		2,500	9,600
45	6 50 to 9.30 pm, \$8 to 12 pm	166	\$20	25	350	16 c p 75c	No		Oct. '89, 3 years.	Natural Gas.	20,000	40,000
90	6 75 average.				250	30 c p 85c, 1 lamp 3 40	No	Heisler.	April '89, 5 years.	Natural Gas.	3,000	14,000
40	\$6 and \$4.	103	\$16 to 2 am.	32	600	\$1 to 1 50.	No	Edison.	5 years.	Natural Gas.	10,000	25,000
24	\$9, \$8, \$7.				2,000	16 c p 75c to \$1.	No	Edison.	'89, 5 years.	Oil.	3,500	50,000
24	\$6.				700	75c average	Yes	Westinghouse.	March '89, 5 years	Slack.	6,000	35,000
20	6 25.	12		50	1,053	16 c p 1c per hour	Yes	Westinghouse.	March '87, 5 years	Slack.	20,000	25,000
50	\$6				40	16 c p 75c	No	Edison.	April '89, 5 years.		8,000	16,000
25	7 50.	250	\$18.	20	1,500	Contracts	Few	Edison.	Jan. '86, 5 years.		10,000	25,000
41	6 50.	184	\$20	25	1,400	16 c p 2 25, 1 12. 75c	No	Westinghouse.	Nov. '88, 3 years	Natural Gas.	3,000	21,000
36	\$6 and \$5.				900	16 c p 50c to 1 50.	Yes	Westinghouse.	Oct. '88, 5 years.		8,000	8,000
100	25c to 12 o'ck, 4c all night				1,600		Yes	Edison.	Dec. '89.	Oil.	2,000	15,000
300	ditto						No		Oct. '89, 5 years.		6,000	9,000
25	\$7 8 hours, \$8 all night.				2,000	16 c p \$1	No	T. & H. altern'g	Oct. '89, 5 years	Natural Gas.	10,000	30,000
17	5 50 to 10 pm.				650	16 c p 85c	No	T. and H.	Jan. '90, 2 years	Natural Gas.	4,000	37,200
28	\$6 average				40	16 c p 50c	No		Feb '89, 5 years	Natural Gas.	18,000	300,000
25	5 50.				379	16 and 20 c p average 75c	No	Edison.	April '88, 5 years.	Natural Gas.	12,000	27,700
112	7 50, 8 33, \$10.						No		May '88.	Natural Gas.	12,000	12,000
135	\$6 average						No		Jan. '89, 5 years	Natural Gas.	100,000	200,000

INDIANA.

53	\$10, 8 33, 6 25				24	50 and 75 c p, 10c per day	No	T H and B.	Aug. '87, 3 years	No	10,000	\$100,000
30	\$6 and \$7.						No		Dec. '89, Expires.	No	8,000	15,000
100	6 25 to 7 50.				2,500	16 c p 25c, 40 and 50c.	{ Cons. furn. meter	Westinghouse.	Aug. '85, 10 years.	No	50,000	600,000
300	\$8 10 50				1,500	16 c p, 1c per hour	Yes	Slattery.		No	45,000	
50	\$5.				750	16 c p, 50c to 85, 25 cp, 95 to 1 25	No	National.		Yes	8,000	24,000
38							No		March '90, 3 years.	No	6,000	15,100
20	7 50 to 8 33½				422	16 c p, 75c to \$1, 1 25, 1 50, 2 25.	No	Slattery.	Jan. '90, 5 years.	Natural Gas.	10,000	13,000
125							No		Natural Gas.	Natural Gas.	18,000	16,500
51	6 25, 8 33½				40	100 c p, 2 25.	No	T H		Natural Gas.	22,000	240,000
40	6 50						No			No	22,000	18,000
150	7 50 to \$15.				600	20 c p, 1 50	No	T H	1890, 5 years	No	40,000	50,000
14	6 50 to 8 50						No		Nov. '88, 5 years.	Oil.	7,000	50,000
23	\$6 to \$8	131	\$24	30	150	{ 60 c p, 2 50, 45 c p, 1 90. 32 c p, 1 25, 30 c p, 1 75.	No	Heisler.	1886, 5 years.	No	12,000	20,000
31	\$5 and \$6.	121	18 11	30	150	{ 16 cp, 65c, 20 cp, 75c, 30 cp, \$1 45 cp, 1 25, 100 cp, 2 25	No	Heisler.	Jan. '88, 5 years.	Natural Gas.	6,000	10,000

SUNDRY MATTERS.

Mr. Printz—I would like to say that the committee on location of the next place of meeting would be pleased to receive applications from any member who would like to have the meeting in his city.

The President—You hear the request of the Chairman of the Committee. The next place of meeting is, of course, a matter of importance to us, and will have to be settled before we finally adjourn. I trust it can be settled to the satisfaction of the Association at large.

The Secretary—Mr. President, by resolution this morning the matter of the consideration of the question of providing for a legislative committee for the ensuing year was deferred until after these papers on municipal control had been read and discussed. I simply call your attention to the fact that this is the time for any action on that subject.

The President—A resolution would be in order that shall be expressive of the sentiment of the Association in this regard; and, for my own part, as it seems to me that an Association of this kind should have some such organization in connection with its movements, I will recommend that some step be taken in reference to this. If any one has a resolution to offer that shall meet the requirements, now is the time to present it.

Mr. Printz—Mr. President, I don't believe that there were many of us who fully understood the subject when it was up this morning, and I think the Committee have failed to make a full report, or didn't appear to know what they were wanted to act upon. As they have given the matter some study, I think it would be well to have the same members continued on that committee.

The President—The report of the committee is to the effect that, in their judgment, their powers and duties are not sufficiently or accurately enough defined; that is one thing. The whole thing indeed seems to be rather vague, and yet there seems to be a pretty thorough idea engrafted upon the mind of the Association at large that there is need of a committee of that kind. I believe that some questions have come up during the present year, when inquiry was made about the legislative committee. I was chairman of the committee, but I could see no possible opportunity for us to take any action in connection with that matter. A conference with the members of the committee also failed to elicit anything, so we were completely at a loss to understand just precisely how far our duties might extend. A report was made that certainly was vague and rather indefinite, but it was all that could be reported under the circumstances. Action was taken this morning that made this matter come up at this time, but if the body wishes further time to consider it, I think there is no impropriety in simply dropping the matter at the present time and bringing it up further on. If the Association so desires it, of course a resolution is in order.

Mr. Graeff—Mr. President, I suppose nearly every member of this Association knows that the electric light people are paying close attention to this matter. A year ago, at their National Convention at Chicago, they appointed a committee, giving the chairman of the committee power to choose his fellow members to give attention to this matter during the coming year. As a result about a dozen state associations have been formed among the electric lighting companies with the sole purpose in view, of guarding the electric lighting interests against adverse legislation. These associations are formed by the companies, not by individual members. They are banded together for mutual protection, as I say, against adverse legislation. The National chairman (Mr. A. R. Foote) of this electric light committee, will probably be here to-morrow, and I think if we would lay this matter over until then that he could probably tell us more particularly wherein lie the dangers that we will have to look after, and which we must guard against. He can probably give us suggestions which it will be wise for us to heed. I, therefore, move you that action on this matter be postponed until to-morrow morning. [Adopted.]

Mr. Cantine—While this matter is before the house I would like, Mr. President, to make the suggestion that very few who are connected with this Association (and possibly the same may be true of the electric light association) have legal minds, and it would be a very nice thing for us if our committee were empowered to employ, in any case of emergency, a first-class constitutional lawyer. Now in Mr. Gemuender's paper which our Secretary read, when the outsider called the engineer's attention to the fact that there was a hole in his boiler, he was very indignant that any person should interfere with his business, but he felt confident that he himself had sufficient ability to legislate. That class of people don't know much about legislation, but if we had a first-class attorney to take care of our interests, who was, like the Michigan peddler, "just middling honest," we would get along with this matter in that way better than with any committee. In case of any proposed legislation we don't know what effect the constitution would have upon it—whether it would be constitutional or not. If it would not be effective, a good constitutional lawyer would say the act would be not worth the paper it is written on, and he comes up and makes his argument, and that is generally the last of it. I think that is the best way to get rid of any obnoxious legislation—to show what its effect would be; to show that it would not be good for anything, and that would be the end of it.

Mr. Penn—I think Mr. Cantine is right. We organized an Electric Light Association in Columbus, and the Executive Committee was authorized to employ a lawyer to look after our interests. They have employed a lawyer temporarily, until our permanent

organization could take place in May. We took the same ground that Mr. Cantine has taken.

The President—Mr. Hedges not being here, we will now call upon our Secretary to read his paper.

The Secretary then read Mr. W. C. Hedges' paper, which was on the subject of

OHIO STREET LIGHTING STATISTICS.

Mr. President and Gentlemen of the Ohio Gas Light Association—What is popular opinion to-day may become unpopular opinion to-morrow. The subject of "Street Lighting Statistics," suggested to the writer, as regards the State of Ohio, by your Secretary, is one of the great questions of the day that interests gas men, not only of our own America, but of foreign countries likewise.

Circulars having been mailed, with a series of questions relating to city and commercial lighting, to eighty gas companies doing business in Ohio and Indiana, and general and aggregate statistics of the companies responding having been made up, the members of this Association will receive a copy of the same by applying to the Secretary.

We find thirty-five cities reported from Ohio, with a population ranging from six thousand and upward. The average net price to private consumers for illuminating gas in these cities is \$1.48 per thousand cubic feet.

Also, in thirty-one cities, ranging in population as stated, the average net price to private consumers for gas used by stoves and engines is \$1.33²/₃ per thousand cubic feet.

Of the forty-one gas companies responding to the circular, five fail to note the number of public street lamps in use. Eighteen companies report 4,436 public street lamps, making an average of 246¹/₂ lamps per company. Eighteen report no public street lamps in use. Twenty-two failed to report size of burners used in public street lighting. Nineteen give full report, showing, by average, that public street lamps burn five cubic feet per hour. Twenty-one companies fail to report as to the maintenance and care of lamps. Twelve reports said maintenance and care reported by the city. In eight of the cities this expense is borne by the gas companies.

It might be well to here call your attention to the fact that only two gas companies report that they are the owners of the lamps and posts connected with their works. One company is owner of lamps only. The cities where balance of companies are located are the absolute owners of lamps and posts. Twelve gas companies are owners of electric light works.

It is very interesting here to note the fact that most of our cities have their streets illuminated by the electric arc system, at an enormous expense, far exceeding the price of gas for street lighting.

As my design in preparing this brief recapitulation is simply to introduce the subject for discussion, I will now leave it to each one of you to deduce, from the gas and electric lighting charts accompanying this memorandum, the fact that the tread of the world is toward gas for light and fuel.

Discussion.

The Secretary—Mr. President, I would like to call the attention of the members, for the sake of having anything of this kind perfect in the future, to the fact that the value of these charts, upon which there has been considerable labor and expense, would be very much greater had the companies all freely responded to Mr. Hedges' circulars, and taken the trouble to fill out the blanks in detail. They are very imperfect. Some companies did not respond at all.

The President—Gentlemen, this matter is before you, together with the charts, and the suggestion of the Secretary, which I consider a pretty important point.

Mr. Printz—I think we certainly owe thanks to Mr. Hedges for the time and care he has taken. Certainly, the charts are very interesting, and yet I don't see how we can do very much in the way of discussion until we have had time to read them and examine them. At the same time I feel under very great obligation to Mr. Hedges for preparing them, and I move a vote of thanks to him. I did not wish to cut off discussion by making this motion. [Adopted.]

The Secretary—Mr. President, while we are on the subject of street lighting I will mention a matter of possible interest, simply—it could hardly be classed as discussion of this paper and these charts—that Columbus is lighted very lavishly and extravagantly with electric arc lights; that the lighting there costs about \$63,000 per annum, which is equivalent to over 60 cents per year for every man, woman and child in the city. The Gas Company, in conjunction with the Oil Lighting Company, there, have canvassed the matter very thoroughly, and have ascertained they can make a bid for lighting the city, leaving the electric lights on all the street car lines in the city and other central streets, at an expense of \$48,000 per annum, saving the city \$15,000 per year, and the city would be as satisfactorily lighted as at present. Notwithstanding that, I have very little hope of our getting such a contract made.

Mr. Printz—I would like to ask Mr. Butterworth if he has any objection to giving the Association the benefit of experiments he has made with Gordon lamps for lighting streets?

The Secretary—Well, that part of the results that will be interesting to you is simply that the lights were very much admired by the council committee on gas and lighting, and by citizens; and that is about as far as it has gone. The council committee on lighting claim that they cannot entertain a proposition from us for

lighting the streets, or cannot enter into any contract for the lighting of the streets, on account of the Burns law. That blocks all further discussion. The matter has come to a crisis there at present though, as some of you are probably aware. It might be interesting, if it would not take too much time, to detail the circumstances. A certain attorney had a bill against the city for services rendered. I do not know the terms of the bargain under which he performed these services, but the city declined to carry out the contract, or to pay him for the services rendered, because the Burns law rendered the contract nugatory. He said, "Gentlemen, if you refuse to pay this on account of the Burns law, I shall get an injunction on the electric light company's lighting the streets, which you are having done in violation of the Burns law." There was no money in the treasury when the contract was entered upon. He also enjoined the city from paying the Assistant City Solicitor for the same reason, and so the night before I left Columbus the streets were in absolute darkness. I don't know how they were last night. The matter will certainly have to be passed upon soon, one way or another, because the people won't go without light.

On motion, the meeting adjourned to 8 P.M.

FIRST DAY—EVENING SESSION.

The President—I will call your attention to the 13th question on this supplementary list: "*Is plate steel or cast iron the better construction for purifying boxes?*" That is a matter of considerable importance. At least I have recently had my own thought directed to it by others, as well as by natural impulse. We have here on the table an exhibition of the use of wrought iron in a stand-pipe, and the question as to its use in other constructions—purifying boxes, for instance—is one that ought to bring out information that should be valuable to us all. I presume no one would object to getting some information as to its value, not only for purifying boxes, but for stand-pipes and perhaps dip-pipes. I recall the fact that the new works at Cincinnati required a very general overhauling, so far as the dip-pipes were concerned, a very short time after they went into operation.

Mr. Hyde—Our new boxes, the boxes themselves, are made of cast-iron, the covering, of course, being of sheet-iron.

The Secretary—Did you consider the use of steel at all?

Mr. Hyde—No, sir; not in ours. We made our hydraulic main and the stand-pipes on one side of the house with wrought iron, and on the other side of the house the stand-pipes are cast iron. We tried to see which was better. We put up a thirty inch main in the condenser room of steel, but seeing that sample up there, and some other things that have occurred, I almost wish we hadn't done it. I don't know what the result is going to be, but I don't think I would be in favor of using it again.

The President—What are your dip-pipes?

Mr. Hyde—I don't recollect, but I think they are cast iron. The hydraulic is wrought iron or steel. Mr. Bredel put them up.

Chair—If I mistake not, Mr. Evans has some practical knowledge in the use of wrought iron mains, and possibly his knowledge may extend beyond that.

Mr. Evans—Mr. President, I have never seen any deterioration in our mains that would lead me to act any differently in putting in mains. In fact I don't think the wrought iron or steel would be affected. I see no reason why, if you get rid of the sulphur, it should be acted upon any quicker than cast iron; but I believe where heat and moisture exist with sulphur that the sulphur acts upon the iron to a greater or less extent. I don't know of any place where wrought iron or steel boxes are in use now except the covers.

The President—To my mind the New York Gas Light Company has a set of steel boxes. I would not assert it, for I am not positive about it, but as memory serves me they are steel boxes, lined with cement. I think Mr. Hyde was with me at the time. I don't know whether he remembers that or not.

Mr. Hyde—I don't recollect about it.

The President—I noticed it more particularly on account of that cement lining. I think they had been in use then some two or three years.

Mr. Webster—I believe we have used a set of wrought iron boxes five years. I don't see any giving out to them, or anything that would indicate anything of the kind. That is the extent of the time we have used them. I don't know how long they are going to last; but I don't see anything about them that indicates any wear.

The President—You say wrought iron—do you mean wrought iron or steel?

Mr. Webster—I think they are heavy boiler iron. That is my impression. They probably may be steel but am not positive. They are riveted together in pieces, the same as boiler iron.

The President—That is valuable testimony. An economic question comes in there that might be of a good deal of importance in a large works.

Mr. Cantine—Most works have plate iron or steel covers that seem to last pretty well, having just as hard usage and being subject to just the same deterioration that the sides and bottoms have. If the covers last, why should not the sides?

The President—In my own experience the covers would not last as long as good heavy cast iron.

Mr. Cantine—That is true, but we have all used them for twenty years without finding any holes in them. I know that is my ex-

perience. They are not over three-sixteenth of an inch thick, and had it been good three-eighths steel, the ordinary American citizen would not live long enough to have seen a set worn out.

Mr. Wilkiemeyer—I have no experience with steel, but with wrought iron I have some little. I took charge of a set of works one time, and when I came into the people's houses they had their doors open to get rid of the foul gas. When I examined into the matter I found that it was caused by the purifiers all being rusty, and I had to build cement walls around the inlets and outlets so as to purify the gas for a certain length of time until I could put in the wrought iron boxes, which I had to buy at once. When I took out the sheet iron boxes I could tear them in pieces like a rag.

Mr. Clark—We have a purifying box, twelve feet square, that has been in constant use since 1878, and I don't think we have ever paid out a dollar of expense on repairs. We have simply kept it coated well with paint. I was examining it the other day, and I saw no trouble with it except one or two rivets. We had it coated over with paint and I think to-day it is good for many years more. I think the top is three-sixteenths. It was a second-hand box, purchased in Philadelphia. In fact, our works were mostly second-hand works purchased in Philadelphia.

The President—You are speaking particularly of the lid being wrought iron?

Mr. Clark—The lid.

The President—You don't mean the body of the box?

Mr. Clark—Yes, the lid and the sides. That is the outside. The water-seal is wrought iron. The inside is cast iron, bolted together in sections, but the outside I think is wrought iron.

The President—I will read the 14th question: "*What treatment or care secures the longest life of a purifying box lid?*"

The Secretary—At Columbus we aim to keep the sides of the lids that dip into the water painted frequently. The part of the lid, of course, that rusts first, is right at the water line. We aim to keep a little "oil on the troubled waters" all the time, to prevent rusting.

Mr. Hyde—Crude petroleum put on to the sides where it dips into the water, or near the water line that Mr. Butterworth speaks of, is a thorough preventative of rust, inside and outside. Apply it occasionally, so that it keeps oily, and it cannot rust. Crude petroleum is the best thing that can be used.

The President—We have practiced, for a number of years and with a great deal of satisfaction, this method. We have taken some little pains to make these surfaces pretty clean, however, and then painted them over, as Mr. Hyde says, with crude petroleum, with a very decided advantage. Perhaps some of these questions may seem, at a glance, unimportant, because they are presented merely as questions. But any one of them would form a good subject for a paper.

Mr. Faben—Instead of painting the oil on, if the oil is merely put into the seal, the cover, in coming up, comes out of the oil last, and in going down enters the oil first, and maintains a constant coat inside and outside.

The Secretary—We put the oil on the surface of the water.

Mr. Geo. A. Light, of Dayton, then read his paper entitled—

ADVANTAGES OF A COMBINED COAL AND WATER GAS PLANT.

Mr. President and Gentlemen of the Ohio Gas Light Association—The subject I am to write upon is one that has received considerable attention, and I do not think I can furnish more information than has already been given in the Gas Light Journals, but I will try.

The gas company that manufactures a gas of fourteen to sixteen candle-power, can no longer satisfy the consumer. He wants something better for less money, and if the gas company can not furnish this he will try something else, and that something else is usually electric light. So the question is, "What is the best and cheapest plan of increasing the candle power of gas?"

There are several ways, but the water gas process is acknowledged to be the most satisfactory method of making a high candle power gas.

By using Lima crude oil in a water gas plant, gas can be made of a high candle power, say thirty candles, at less cost per thousand feet than by any other method. A coal gas plant can be run more satisfactorily, and the gas made at considerable less expense, where a water gas plant is being run in connection with it. No idle benches on Sunday or Monday, no extra benches under slow fire, ready for sudden increase in consumption. The variation in the output is supplied and controlled by the water gas plant. For instance, we will suppose the average daily consumption is 500,000 feet. The coal gas plant has four benches of sixes and four benches of fives, making 300,000 feet of sixteen candle-power gas per day. The water gas plant consists of two sets of Granger generators and superheaters, capacity 400,000 feet of thirty candle power gas per day. The 200,000 feet of water gas that is required to make up the daily output of twenty-two candle power gas, can be made in the daytime by running both sets (this I consider the best plan), reversing the night watch for extra work. If the output should suddenly increase on account of several successive dark days, the required amount of gas can be made and kept on hand by running an hour or two extra at night; or, if the increase be a gradual one, the extra gas required can be made at night until your increase in consumption justifies starting another bench.

When the output of a water gas plant making 30-candle gas is more than two-fifths of the total amount of gas made by the com-

bined plants, the candle power can be regulated by the amount of oil used per 1,000 cubic feet of gas.

In a city or town where natural gas is in general use it is a difficult matter for a coal gas company to dispose of coke at the price obtained for it before the introduction of natural gas.

The water gas plant is then a good customer for the coal plant. It decreases the amount of coke made and helps to keep up the price of that you have for sale by using a considerable amount of it. It requires 45 pounds of coke per 1,000 cubic feet of gas made (coke made from Youghiogeny coal).

An engineer or superintendent of a coal gas company, who has a water gas plant in running order, does not lie awake at night, planning how he will overcome the trouble his stokers are causing in the retort house, or will cause him by striking at the time he is least prepared for it. The water gas plant is the best "peace-maker" that I know of. The stokers know, or if they don't know, very soon find out that, in an emergency, two men in the water gas plant can make as much gas as twelve men in the coal gas plant, and that it requires but one skilled man for each watch, and they are generally old and tried employees.

Discussion.

Mr. Light—Now gentlemen, the reason I did not make this paper any longer is because the last issue of the AMERICAN GAS LIGHT JOURNAL contains two articles which I think thoroughly cover all the ground.

The President—You have heard a brief presentation of facts from the experience of one in daily practice. I trust the points thrown out may be the nucleus of a discussion that will be valuable to us in this connection.

Mr. Penn—I would like to ask Mr. Light if he would think it advisable for a small town like Washington Court House to put in water gas plant?

Mr. Light—Yes, abandon your coal gas plant. That is what we have done at Piqua.

The Secretary—Which costs the more in the holder, coal gas or water gas?

Mr. Light—Water gas.

Mr. Booth—What sized generator do you use?

Mr. Light—We have two. I think they are called six foot generators. I don't remember the exact size—I was trying to think of it this afternoon. It is a seven-foot shell.

Mr. Booth—What amount of gas do you produce to each run?

Mr. Light—Between 3500 and 4000.

Mr. Booth—Do you fire up every 15 minutes?

Mr. Light—No, we run ten minute runs—blow ten minutes and make gas ten minutes.

Mr. Booth—Can you get up heat in ten minutes?

Mr. Light—Yes, sir, with coke made from Youghiogeny coal. You cannot very well with hard coke.

Mr. Booth—That is your gas house coke?

Mr. Light—That is coke that comes out of our retorts.

Mr. Booth—At Bellair we have the Crichlow process.

Mr. Light—We have the McKay-Crichlow at Piqua, and we have a Granger at Dayton.

Mr. Booth—Ours was put up for a natural gas plant. In running natural gas there we would run thirty minutes.

Mr. Light—We don't use any natural gas at Dayton, but when I left we were preparing for it.

Mr. Booth—It would require about thirty minutes to get up a heat. Once in a while the natural gas would fail us, and we would get short. We would then make water gas and run about ten to fifteen minutes, but it took us longer than the time you specify to get up heat, and our experience was that it cost as much or more to make water gas as it does coal gas.

Mr. Light—With our Piqua plant we can make gas a great deal cheaper. We have one difficulty there, we can't sell coke at a reasonable price. We have between six and seven thousand bushels of coke there that they are using up in that way.

Mr. Booth—There may be a misunderstanding as to what I mean in regard to its costing more than coal gas. When we deducted the receipts from coke and tar from the cost of the gas the coal gas was cheaper than the water gas.

Mr. Light—Are you comparing candle power?

Mr. Booth—Well, you might have a little higher candle power.

Mr. Light—I think if you bring your coal gas up to 22-candle power, you will have to use cannel coal as an enricher.

Mr. Booth—We always made our ordinary coal gas of 16 or 17 candle power, except when we ran the Crichlow process, when we got a higher candle power.

Mr. Light—At Dayton we had to come to it or let the electric light get ahead of us.

Mr. Booth—At the present price of coke and tar I think coal gas, unless the coal costs too much, can be made at least as cheap as water gas.

Mr. Light—Have you natural gas in your town?

Mr. Booth—No, not much.

Mr. Light—You say you have a market for your coke?

Mr. Booth—Since natural gas has failed we sell our coke to the glass houses and cannot produce enough of it. We sell it cheap compared with what they do in some places. We only get four cents at the works. Of course the glass house hauls it away.

Mr. Light—We get ten and twelve cents in Dayton now for what we do not use up. Of course we could not get that unless we were using a good deal of it up in the water gas plant.

Mr. Rood—The gentleman spoke of using natural gas in the manufacture of illuminating gas. What proportion of natural gas can you use to advantage in making illuminating gas?

Mr. Booth—That is a question that I don't believe I can answer.

Mr. Rood—What effect upon your gas does an excessive use of natural gas have?

Mr. Booth—It will weaken the candle power, of course. If you use too much natural gas your candle power will be that much decreased. We aim to use, I believe, about 3 to 4 gallons of oil to the thousand feet produced, but when natural gas went through it was not measured. We opened the pipe.

Mr. Rood—Is it possible to enrich the natural gas passing through your generators so that it will make illuminating gas as acceptable as water gas?

Mr. Booth—Well, I never could discover any difference in the quality of the gas when you use the natural gas, from what it is when making straight water gas. Very frequently the natural gas would fail, so that we had to make half runs with water gas. Some days, altogether water gas.

Mr. Rood—Is it much cheaper to use natural gas in manufacturing your gas, than to make pure water gas?

Mr. Booth—There is not much difference. Of course we paid a pretty heavy dividend to the natural gas companies in order to get the natural gas.

Mr. Rood—What did you pay per thousand feet?

Mr. Booth—We paid twelve per cent. of our gross receipts. We did that to keep them out of the field.

Mr. Rood—Then you would not consider the use of natural gas a great advantage in making gas?

Mr. Booth—It was not in our experience. It cost more than coal gas, as I said, after deducting the price we got for the residuals.

Mr. Rood—But you made a gas of higher illuminating power?

Mr. Booth—Yes. We haven't run, however, for nearly two years, because we didn't get enough natural gas. We had to have pressure enough to force it into the holder. Whenever it got below that it would goback into the pipes, and we didn't think it good policy to make gas to go back into the natural gas mains, so we stopped.

The President—I see Mr. Faux is here, who, I think, can give us some experience in this direction that would interest us.

Mr. Faux—Mr. President, I came here to be a listener—a looker-on. I did not expect to have a chance to give my experience in this matter, but as it has been brought out I feel like saying something. In the matter of enriching natural gas, my experience is quite extensive. We spent a great deal of money, and tried to make it a success. I found that by using a small portion of natural gas there was no trouble in getting candle power, but if you used over a certain amount of it your gas would be smoky and red; and you couldn't hide it, no matter how much steam you put in it. For outside purposes, such as street lighting, it was very poor. Just as soon as the least draft of air would strike it, it would go off in a blue blaze. Of course people soon found out what did that. We tried that about a year. We used 5, 10, and sometimes 15 per cent. to see whether we could get anything out of it. We got the natural gas part of one year for 1.9 cents per thousand feet, through the station meter; that is, we paid the natural gas company 1.9 cents per thousand for every thousand feet of gas that we made that went through the station meter. The second year we paid six cents per thousand feet for natural gas. But we abandoned it entirely, from the fact that we could not make a success of it. As far as candle power was concerned, it was all right. I find other parties are using it, but I speak from my own experience only. The gas was not satisfactory to ourselves. This matter of water-gas comes up here, and I am glad it has been brought up. I am in the same position. Three years ago I took charge of the works on the Southside. They were using what I call a number one coal—that is, the best lump. They were paying \$1.54, I think, per ton, delivered. I looked over the matter—I was sent from the eastern part of the State—and my figures were set—that I must put gas in the holder at a certain price. I looked over this matter and found I couldn't do it with coal at \$1.54, and coke at three cents a bushel after it was crushed and screened. I thought I would try another coal. I think that cost me about \$1.25. My results were not satisfactory. The gas still was costing too much in the holder. I then came to the conclusion that, as I had this water gas plant, I would try something different. I tried 2,000 bushels of slack, just this common slack that they screen from the mines, and I found that I could get a pretty good yield out of it and by using a small quantity more of oil I could get the desired candle power. So instead of using \$1.54 coal I am to-day using 50 cent coal—costing me fifty cents delivered at the works—and with about $\frac{1}{2}$ or $\frac{3}{4}$ of a gallon of Lima crude, which costs me now 65 cents a barrel, I have my desired candle power, which runs from 22 to 24. All this is done with the aid of a water gas plant. If I hadn't this water gas plant I could not nearly get that candle power. So I think, in works of ordinary size, where they can combine the two, the water gas plant is the thing.

The President—What yield do you get from that slack as compared with your inch and a-half screened coal?

Mr. Faux—Well, I regulate that a little bit to suit myself. I can get all the way from 3.50 to 4.44 feet. If I am a little short of gas, I set the exhauster up pretty heavy. If I don't need the gas, I go the other way on the exhauster, about three-quarters of an inch. If my gas is poor from that slack, I just push in a little bit more oil at the other end.

Mr. Rood—The gentleman said he used different proportions of natural gas. What proportion of natural gas did you find you got the best results from?

Mr. Faux—When I used about five to eight or ten per cent., not over that, I could get fair results; but it didn't matter what the candle power was, as soon as a gust of wind struck it, it told on it, from the fact that there was no weight in it. It would blow off in a blue streak. For inside lighting, where there was no wind, it was very nice, but outside in the street it was not good. Our street lamps there are very peculiar. They have no bottom in them, as I say. It is so that the lighters can do the lighting with a stick. A draft of air would blow the lights out, and we had more "outs" when we were using natural gas than we have had since.

Mr. Rood—Did you find that five to eight per cent. of natural gas is an advantage?

Mr. Faux—Well, I don't know. It would depend considerably upon the price you could buy your natural gas for. If you could buy it cheaper than you could make coal gas, it would be an advantage. Otherwise, I don't think it would be.

Mr. Rood—Would it be of advantage to pay twelve cents a thousand feet, and use it in that plant?

Mr. Faux—That would depend upon the cost of coal in your locality.

Mr. Rood—Suppose you were not making coal gas at all, but were making water gas.

Mr. Faux—Then it would be an advantage, because your natural gas will run—well, our Pittsburgh natural gas is about eight candles. That is about the general run of it. We have that eight candle gas already made for that twelve cents and I don't think you can make water gas of eight candle power for twelve cents.

The Secretary—Mr. President, at Richmond, Indiana, Mr. Starr tells me that 25 per cent., by volume, of the gas in his holder is natural gas, and 75 per cent. water gas. He uses three gallons of oil to the thousand feet, enriching it, and he and his consumers are very well satisfied.

Mr. Rood—What candle power is his illuminating gas?

The Secretary—I forget; but it is high.

Mr. Rood—What advantages did you find in using an excessive amount of natural gas other than those you have mentioned?

Mr. Faux—I don't find any other advantages.

Mr. Rood—Are any hydrocarbons carried off through the mains that trouble you?

Mr. Faux—No, sir, we had no such trouble. I believe, if anything, it was a benefit rather than a detriment, because the hydrogen in the natural gas absorbed the carbon that laid in the mains in the shape of oil and tar. Answering Mr. Rood's previous inquiry, I remember that while using natural gas a tremendous number of our meters gave out, which I believe was caused in a great measure by the dryness of the natural gas, which seems to be of such a composition that it has an affinity for the oils in the diaphragm of the meter. Since we have abandoned the use of natural gas our trouble in this respect has not been one-third what it was during the time of its use. Our city is divided into three sections, and it would take two men two days to get the bad meters in, but I think last month not over two imperfect ones were reported.

Mr. Rood—My experience is similar to that of Mr. Faux with reference to meters. We are using some natural gas, and although I am not well enough acquainted with its use to say what the benefits or the troubles arising from it are. I may say we are having trouble from our meters.

Mr. Faux—I saw some of these questions before I came here, and hoped that Mr. Young or Mr. McElroy would be here.

Mr. Booth—We have had an experience similar to that mentioned in respect to meters.

Mr. Smith—What was the comparative price between water gas and coal gas?

Mr. Faux—I could not say that because the Southside has used water gas more or less all the time.

Mr. Faben—I don't think the effect on the meter, as between the coal gas or water gas, would be very different, if both of the gases were equally well made. One advantage in the mixture of coal gas with water gas I have not heard stated. The flame temperature of water gas is very high and the total heat of combustion comparatively low. A very small, energetic combustion and a small flame. If the ordinary run of burners are used in consuming it, a large burner would be apt to throw off smoke. A large burner would throw off free carbon (although the flame would continue bright, and would not indicate it), and free carbon would be deposited about the room. Now, if we can add to that gas a quantity of light carbureted hydrogen, that has a low flame temperature and a large total heat of combustion, requiring the large amount of air that it does for its combustion, by increasing the size of the flame—increasing the flame area without changing its illuminating quality—in that manner we will remove the smoke difficulty. The only objection to using a large quantity of natural gas would be to give the gas too large a percentage of light carbureted hydrogen, and, requiring that large amount of air for its combustion, the flame itself would be very apt to leave the burner tip with a little air disturbance—to spread itself, without the necessary amount of oxygen in the atmosphere to bring on combustion.

Mr. Cantue—It used to be said in the revival meetings of our country that "Honest confession was good for the soul." About this time last year a little competition stared me in the face, and I

struck out to get reinforcements. I contracted for a water gas plant, but the plant was a little too small to work nicely. It was a four foot cupola. It worked during the summer very nicely, but the manner in which it was connected with the old coal works made it impossible to work the two together. Having only one holder, it was a little difficult to do. When we are working one, the other would have to shut down. We met the enemy, and I don't know whether they are ours or we are theirs; but we have captured a good many of their pickets. We made a good gas—higher than the Jones photometer would indicate, but we had something that was not just as sweet a thing as water gas ought to be. It was the foulest institution the undersigned ever had anything to do with. We found it required from eight to ten hours to clean the thing. The rest of the time we made gas. We were always in that muss, and we are yet. It was no trouble at all for anybody on the street to find out what kind of business I was in; they didn't need to ask any questions. It was impossible to live in the same house with me. The odor was simply frightful. Now, we propose to get out of that scrape by making coal gas, and when the thing gets down to about the point the public will complain, we will start this thing up. I think I aged about ten years in six months. I used to grow old—to get a little old—when the holder was going down, and it was a question if it wouldn't strike ground; but this thing has hurried the matter up a little. I would like to ask Mr. Light whether we will be compelled to stay out nights with picks and shovels and bonfires to get rid of the naphthaline that will be made?

Mr. Light—That question, I think, hits the nail on the head. We don't use picks and shovels, but we keep portable boilers out. I think that is the best method to get rid of it. Every Fall-November is our worst month; for three or four nights we have to have a portable boiler out steaming out our pipes. It would seem impossible that 10 or 12 or 16 inch mains will be clogged up in that way; but they will. Nine times out of ten you will find the naphthaline just beyond the drip. Then we run in a barrel of naphtha, turn on as much steam as we can get in, say 50, 60 or 80 pounds, and leave it on 15 or 20 minutes. Going to the furthest lamp post away, where the grade is down to the drip, we put in another half barrel of naphtha and pump it out at the drip, and it will take up all the naphthaline with it that the steam has dissolved. We have done this for two years. I don't know whether we will have it next year or not. I have tried everything that I can think of to stop it. We have it now in the works. I saw it the day before I left. When we first put in our water gas plant I thought: "This settles the naphthaline question." That was the hobby at first; no naphthaline where there was a water gas plant. We ran four or five months and choked up the inlets and outlets of the holder. We had it in the works the most part of that season, but that season it did not show in the street. Next season it left the works (we have not had it in the works since to any great extent), but it appears now on the street every year. Why it changed is something I can't say. It seems almost impossible to control it. As to using picks and shovels, we used to dig down and cut our mains, but found the portable boiler to answer the purpose better. Of course it must be done at night. We can't do it in day time on account of teams and things of that kind. By the way, we have one particular place—talk about going to bed and going to sleep! We have a great many hydraulics. At one particular place where we cross the hydraulic, I suppose, it runs eighty feet under the water. I remember the first time we had it, last Fall, it stopped the main solid. We cleaned it out, and the following night it was stopped up again. The way we cut it out was by putting in between five and six barrels of naphtha. We had a good deal of naphtha on hand, and simply filled that pipe under the hydraulic and pumped it out again. I think that stopped four or five times. Sometimes not two days would intervene before it would stop up. It kept stopping up that way, until we finally cut it off and ran it across the top of the bridge, when we didn't have any trouble afterwards. But that shows the way it deposits. Inside of 24 or 36 hours it will stop up a 6 inch pipe. If anybody knows any way to get rid of it, I would like to know it.

Mr. Faux—Up to this Winter I was in the same condition as Mr. Light. Until last July I used benzine of 65° gravity, and sometimes I would have two men out all the time cleaning out lamp-posts and consumers' services. One day it would be in one part of the town and the next day in another part. About the time people would want to light up in the evening the telephone would begin to ring. I didn't know what in the world to do. It was naphthaline all the time, station meter, inlet and outlet of holder, etc. I remember one time there was a stoppage in the inlet of the holder, when we had to put a big piece of iron on the end of a rope, and let it down to break that stuff. Last July I began to use crude oil. I put in a scrubber, which consisted of a boiler 25 feet long and 44 inches diameter. There is about twenty feet of solid filling in that boiler, and the wood is cut two inches wide. It is an inch on the bottom, and runs to a point on top, making it the shape of a V. I began filling within two feet of the bottom, turning each row at a slight angle with the one below it. After I got my boiler filled some of the gas men thought I would never get any gas through that, but I was going to try it. I put on what I call a scrubber pump, that would throw a 1½ inch stream of water, hitched an engine to it, placed a barrel at the outlet and fed it with a small stream of fresh water about as thick as your finger, then pumped that liquor from this barrel into the top of the scrubber. Last Winter in condensing I would not allow my gas to get below 65°

if I could help it, no matter how cold the weather was. This Winter I let it go down as low as the temperature of the water would make it. I can't recall an instance where I have had a service stopped up by naphthaline this season. I have not seen a speck of naphthaline around the whole works, except in the bottom of the purifier when the material is taken out and thrown in the air. I noticed one morning that the temperature of the gas was down to 34°. It was condensed that low before it went into the holder. I can't say whether the pumping, and the condensing of that gas to that low temperature, have relieved me of naphthaline or not; but I have no signs of it anywhere.

Mr. Light—I don't think the remedy is in your scrubber; for we have the same identical thing. We pump the water over and over, and we have been doing that for the past two or three years. We aim to run at 60° temperature. Whether your relief is on account of the low temperature that you carry or not is a problem.

Mr. Faux—I am going to try to keep it at 45°, or as close as I can to that, to see whether that trouble will occur again. I want to find out what has been the cause of it. This is the first Winter that I have been free from naphthaline.

The President—I would like to inquire of Mr. Faux whether the extreme cold whether showed more or less naphthaline than warm weather?

Mr. Faux—Previous to this Winter?

The President—Yes, sir.

Mr. Faux—Well, I think during cold weather the changes of temperature would close me up. But this Winter I have experienced no trouble with these sudden changes.

Mr. Clark—I have had a little experience in the water gas business. About five years ago I took charge of the Elyria Gas Company, and my hair then was quite dark. In two years I felt a good deal as Mr. Cantine did. I threatened to resign and leave the Company. I would say to our President that I was disgusted and discouraged with the gas business, and wanted no more of it; but he encouraged me to hang on, and, as Mr. Light and Mr. Faux say, my pipes filled up, and how to free them I did not know—without taking a shovel or pick, or something of that kind. I labored day and night, and derived no especial benefit. Many visitors gave me advice, and I tried the remedies suggested, but without obtaining any lasting benefit. Finally a party came along who said he *could* make water gas. I replied, "You are the man I want; if you can get me out of this trouble I would like it." He took hold and ran his heats and everything entirely different from the party I had had, and the result was that my tar and lampblack ceased. We ran our heats about thirty minutes. We got a good cherry red on our generator, and a good straw color on our super-heater, and made 5000 feet to a run, and had less lampblack and tar. It began to let up at that time. I changed men again, and the last man thought he could improve on it somewhat, so he introduced hot water and steam when we had any trouble. The result was, if we had any trouble or stoppage we applied the steam and followed with hot water, and now to-day we have but very little trouble. In fact, we look at it as such a small matter that it is no bother at all. I lose no sleep, and we are working nicely. But I would say we have never used Lima oil. We have always used 63 naphtha, and experienced the same trouble earlier with the naphtha that they do now with the Lima oil. Now I am making a 22 candle power gas with 4½ gallons of naphtha and 50 pounds of anthracite coal. I find I cannot get as high candle power with coke as I can with anthracite coal. We used the Rochester coke—what they call 72 hour coke—and when we make gas from it I find we cannot get our candle power as high as we can with anthracite coal. Our generators and super-heaters being so small that we get too heavy heats—that is we have to get too heavy heats—which practice is very destructive to our works. I really begin to like to run gas works; before I was sick of them.

Mr. Hyde—Mr. Clark, what has remedied the difficulty?

Mr. Clark—Well, I used to lay a good deal of it to Mr. Benham, the Standard Oil Company man. I thought they were not preparing their naphtha right. I thought they had changed it. But he laid it to our man not understanding properly.

Mr. Hyde—Are not the high heats responsible for naphthaline?

Mr. Clark—High heats make the lampblack.

Mr. Hyde—And the naphthaline also?

Mr. Clark—Yes, sir. I think there is also something in the process by which they prepare their naphtha. I know we have no trouble now. They claim they are making their naphtha the same, and we have no trouble with it at all.

Mr. Light—I do not know of any gas apparatus that will cause more trouble than a water gas plant, unless it is run on correct principles. It is the easiest thing imaginable to choke it up suddenly. The least change will make lampblack on one side, and if the heats are too low you will make more tar than you should. My experience is that you cannot use too much water in your seal. I find that a way to get rid of that hard, pitchy, tar in the seal is by drawing the seal off completely. As soon as we put on a run we open the four-inch cock at the bottom and draw everything out. It cleans the seal out completely, so that there is nothing in there to thicken up. By running with careful heats there is no occasion at all for lampblack, and the lampblack is what causes the difficulty in a water gas plant.

Mr. Printz—I would like to ask Mr. Light if he had this same trouble with the naphthaline when he was using naphtha instead of Lima oil?

Mr. Light—We had the same trouble. We have been running

the plant two years. We commenced using crude oil there the latter part of March or April last year. We never run strictly on naphtha, except when we could not get the crude oil. We generally run two-thirds crude oil and one-third naphtha, but we have had the same experience both years. There were very few occasions when we had to run on naphtha alone, except when we were delayed in getting crude oil. The reason we abandoned naphtha altogether was because the Lima naphtha contains too much sulphur. We had to put the whole force at the works into the purifying house; and so we abandoned it altogether.

A Member—Did you have any trouble with your superheater getting clogged up with lampblack?

Mr. Light—No, the super-heater will not clog. The deposit of carbon that is formed on the brick on the inside is burned out by letting the plant stand idle at night, with a small draft on the generator. We leave a draft in the bottom of our generator and it heats up the super-heater during the night. In the morning when we fire up it throws out a perfect cloud of white, greasy substance. We have been running twelve hours a day since last June with one set, and we have never taken a brick out and never been inside of it.

Mr. Cantine—I was going to tell you of a little trouble I had about the stoppage of our inlet pipe. I tried steam and naphtha and benzine and gasoline, and all the other materials that come from distillation of coal oil. The quantity of gas in the holder was very small. Night came on and yet we couldn't get a foot of gas through. Steam had no effect on it. I didn't know what to do. I was about in such a dilemma as the man, alone in his house, who had the quinsy, and who looked through the cupboards for some kind of medicine, and couldn't find anything until at last he found some kerosene oil. He took a dose of that and it cured him. I dosed it with oil and then took cold water and put it in, and I have never since had any trouble with naphthaline. I never got anything but a tarry naphthaline. It looks like jelly. I don't know how it came nor how it gets into the inlet.

A Member—I don't think we have had any confessions from Mr. Faben yet on this subject.

Mr. Faben—I have not any to make. A double water gas set of our own selection was put in our place and was operated by the employees of the Company that placed it there. They had some trouble. When the apparatus was handed over to us we took new men who knew nothing about the gas business or water gas apparatus. They had everything to learn and nothing to forget. They did just what they were told to do—very closely observed the operation of the apparatus when under the charge of the gentlemen who put it there. I noticed the trouble that our friend Cantine speaks of would always occur when we had anything but uniform heats. When the apparatus was strikingly hot in some particular spot the men would perhaps not be able to introduce oil in that run because that part of it was too hot. As they hadn't put anything in there to cool it, the next run it only went that much higher, and they would have to use some heroic treatment; and that was to put in a good big dose of oil, and then they made lamp black. But our apparatus is different from many used and spoken of. We have an arrangement of the combined Lowe and Granger. It has three cylinders. The first cylinder is the generator. That is of good size. It has the diameter of a Granger set and it has the modified length of a Lowe set. With that apparatus—that particular form of generator—we are enabled to use soft coal. With a short blast, say six minutes, we can bring that fuel to a very high incandescence, and then make water gas for nine minutes. In the second cylinder we vaporize the oil. The oil is atomized, having been heated in a steam coil before entering, so that the very light portions of the crude oil are vaporized by the steam heat, and the heavy portions atomized in escaping through the fine orifice and getting in there. It is showered in, and any portion of the oil that is too heavy for atomization or evaporation under the conditions named, lodges on this brick work. The temperature of the brick work is maintained at a low degree, so as just to evaporate it and let it pass on with the incoming gas. We don't undertake to gasify that oil in there. It is simply to vaporize it. When it comes down to the bottom of the cylinder, there we have a volume of water gas wrought up with the vapors of crude oil. Then it enters the bottom of the super-heater. In the super-heater we attempt to gasify it. It has a large damper. The length of that cylinder and the primary proportion of vaporization of the oil properly enable us to gasify that oil first in passing through that super-heater without exposing it to a very sharp heat. A very moderate heat will do it by treating the oil in that manner. We can look into the super-heater during any portion of the run, and it is perfectly clear in there. The gas coming through does not cloud it up until towards the end of the run, and then, on account of the disappearance of heat, the vision is obscured. I have not had—I have been fortunate in that respect—any naphthaline trouble in or about the works, or in any street mains, or with any consumer.

Mr. Hyde—The secret of the cause of naphthaline is the high heats. I know, from experience with the manufacture of coal gas, that the original cause is the high heat, and then the rapid cooling afterwards.

Mr. Faux—In speaking of naphthaline before, I left something that I will explain now. I have what is called a Granger machine, that was built for benzine alone. That is, it takes oil in the bottom of the super-heater. With super-heated oil at 150 pounds pressure the engineer had considerable trouble. He almost blew up the whole works a number of times. The outlet of the super-

heater would elog up. I did not know what to do. He had his oil lown in the ash pan and all over everything. I was in a bad fix. I was like Mr. Cantine for a while—I felt like clearing out. I took hold of the machine, ran it myself for a week or so, and found there was something wrong. I didn't know what it was, but I made up my mind if I would change the machine it would do better. I took off the cap, deepened the fire and changed the inlet from the generator to the super-heater. Then it would go down the side blast pipe. In explaining this I suppose many of you have seen a cut of the Granger process. I came to the conclusion that if I could stop that from going down there I would have the thing about right. I let the machine cool down and got in there myself, I commenced to wall opposite the end of the super-heater blast pipe, and placed the brick in such a position that the oil could not get back into the pipe, compelling it to meet the hydrogen gas coming from the generator in the bottom of the super-heater. It worked perhaps for two weeks all right, and then it would back behind this wall. I studied the matter over. I had been looking up the new process—this new Granger machine that Mr. Faben has in operation—and I made up my mind I could get the results with this machine. I put a tuyere right under the second arch and sprayed my oil in there. I made a loose checker-work between the two arches where the oil has a chance to drop down and evaporate below. I now have no trouble. It is as clean as it ever was with benzine. There is no tar, and there is no trouble with the outlet or anything else. I run with very high heats in my super-heater, and there is no sign of naphthaline.

Mr. McDonald—Mr. President, I am not a gas man, as you know, but I have listened to this discussion. I think probably most of you agree with Mr. Hyde, that high heats have something to do with this; but from what I have heard of the discussions of water gas, I am of the opinion that the bringing of the oil to a high heat suddenly is the cause of the trouble. If the oil is brought to a high heat slowly, I think the trouble will be much less. I know it is generally conceded that it is much better to bring the oil up gradually, vaporizing it first and then introducing into the apparatus afterwards.

On motion, a vote of thanks was passed to Mr. Light.

AN INVITATION.

Mr. Faben, on behalf of the Toledo Gas Light and Coke Company, then invited the Association to a dinner, to be served in the Budy House on the following evening, which invitation was, on motion, accepted with thanks. The meeting thereupon adjourned.

SECOND DAY—MARCH 20—MORNING SESSION.

The President announced that a neat souvenir badge had been presented to each member of the Association by the Central Chandler Company of Toledo, accompanying their invitation to visit their show rooms and factory. The meeting took appropriate action expressing its appreciation of the memento and the invitation.

A letter was also read from Mr. Scott, President of the Board of Trustees of the Manual Training School, inviting the members of the Association to visit the school during their stay in Toledo. On motion, a vote of thanks was given Mr. Scott for his invitation.

A resolution introduced by Fred. R. Persons, endorsing the action of the National House of Representatives in selecting Chicago as the site of the World's Fair, was, on motion, adopted.

Mr. G. A. Hyde, sen., of Cleveland, then read his paper on

OUR NEW COAL GAS WORKS.

Mr. President and Gentlemen of the Ohio Gas Association—I esteem it an honor to be chosen a member of this Association and complimented in being requested by your Secretary to prepare a paper entitled "Our New Coal Gas Works."

The portion of the city of Cleveland lying on the east side of the Cuyahoga river is supplied with illuminating gas by the Cleveland Gas Light and Coke Company, and the west side by the People's Gas Light and Coke Company.

This paper relates to the former Company only. The old, or No. 1 Station is located at the extreme northwest corner of the territory supplied, and has proven to be a desirable location from which to suitably meet the requirements of that portion of the city.

Looking to the future, the question of duplicate feed pipes to, or the erection of supplementary works in the outlying district had to be considered, and, after due deliberation, a conclusion was reached that it would be best to erect supplementary works.

In furtherance of that plan a plot of land was purchased near the shore of the lake, at a point three miles eastward of the old works.

The plot contains about eight acres of ground, and is located between the main track of the Lake Shore and Michigan Southern Railroad and the Madison avenue branch of the Cleveland and Pittsburgh Railroad, thus affording excellent facilities for the receiving of material used in the construction or repair of the works, the receiving of coal and shipment of residuals. A brook runs through the grounds, which furnishes an abundance of water suitable for quenching coke and for the benches. Water for boilers and washers is obtained from the city water system.

As a basis for planning for the construction of the new plant, it was considered advisable to provide for the manufacture of 600,000 cubic feet of gas per day to meet present requirements; but, deeming it prudent to be mindful of the future, the houses and machinery were placed and distributed in manner to conform to a general plan contemplating a works having a capacity of 5,000,000 cubic feet.

The retort house, benches and coal shed were built for a capacity of 600,000 cubic feet, but they are placed so that they can be extended to the ultimate full capacity.

The boiler, exhaustor, condenser and washer houses are joined together in the order named. The boiler house is of a size sufficient for all future requirements, and incloses two boilers for immediate needs. The exhaustor house is ample for all future demands, and contains two exhaustors for alternate work, each having a capacity of 2,500,000 cubic feet. The condenser house has a capacity to contain apparatus capable of properly condensing 3,000,000 cubic feet, and is so arranged that additions can be easily made to provide for the further amount of 2,000,000 cubic feet. The apparatus now set will properly condense 900,000 cubic feet. The washer house now contains one set of tar and ammonia washers of about 1,200,000 cubic feet capacity, and has space for another set. Provision was made for extending this house to receive two more sets of washers.

The purifying house, with its one set of purifiers, 25 feet by 25 feet, and the revivifying house attached, can properly pass 1,250,000 cubic feet of gas, and the building and inlet and outlet pipes are so placed that they can easily be extended to the capacity of 5,000,000 cubic feet.

The station meter house contains one station meter, 12 feet by 12 feet, having a daily capacity of 1,700,000 cubic feet, and ample room remains in the building for placing two more of same size.

The first gasholder, having a capacity of 600,000 cubic feet, has two sections of 110 and 111½ feet diameter, respectively, each section 32 feet high, contained in a tank of 114 feet diameter and 32¾ feet depth, inclosed in a brick house surmounted with a non-trussed wood roof, covered with slate. Adjoining this building is the governor and valve house, being centrally located for connections with the present and all contemplated gas holders. The piping and valves are so arranged as to admit of inlet and outlet of each holder being controlled in this building.

Two tar and ammonia tanks are located convenient to the retort house and condenser and washer houses, each having a diameter of 40 feet and a depth of 35 feet. The pump house is adjacent to the last named tanks.

The retort house was constructed especially for the convenient use of regenerative benches. The floor consists of I beams covered with ribbed steel plates. Tracks and turntables are laid contemplating the use of steam charging and discharging machines, and the house is arranged for erecting overhead coal tracks and storage bins for supplying the charging machines.

A system of water piping for fire protection, connected with the city system, is distributed through the entire plant.

The main gas pipe running through the works is thirty inches in diameter, is exposed to view, and placed ten or more feet above the ground, or floors, from the retort house to the outlet of the station meter house, excepting for a short distance between the purifying house and the station meter house, where it is placed under the surface of the ground.

I wish to call attention to this feature of our work, as it differs from the usual custom. These pipes are easily reached in case of leaks, require no basements, and permit of free access to all the machinery.

The buildings are placed in the following order, viz.:

The coal house adjoins the Lake Shore and Michigan Southern Railroad, is 100 feet wide, has a branch elevated railroad track running lengthwise along its centre, allowing the "storage" coal on one side, and the "present use" coal on the other, and nearest the retort house.

A space of twenty feet intervenes between the coal and retort houses, thirty-seven feet between the retort house and the boiler, exhaustor, condenser and washer houses, and thirty feet between the last named and the purifying house, and attached to revivifying house. This last named house lies alongside of the track of the Madison avenue branch of the Cleveland and Pittsburgh Railroad.

The benches are of the Kloeene-Bredel Regenerative pattern, and were erected by Mr. Fred Bredel, of New York city.

The exhaustors were manufactured and placed by the P. H. & F. M. Roots Company, of Connersville, Ind.

The condensers are of the open-air plan, but divided into rows every two feet, each row containing twenty-four six-inch pipes, of twenty-four feet in height each, and having a daily capacity per row of about 150,000 cubic feet. This method was first introduced in our present old works in 1872, and proves satisfactory. It has the advantage of making it possible to give, at all times, the same condensing treatment to the gas, whether much or little is being manufactured, but which can not be done by a single line condenser, whether open-air or multitubular water condenser. By having valve at each end of each row, there is obtained the further advantage of being able to shut off by single rows for cleaning.

The tar and carbonic acid extractors and ammonia washers were furnished and set up by Mr. Fred Bredel, of New York city. R. D. Wood & Co. furnished and placed the set of four purifiers and dry centre valve. The Maryland Meter Company, of Baltimore, Md., furnished the station meter. The Stacey Manufacturing Company,

of Cincinnati, O., furnished the holder, and Helme & McIlhenny, of Philadelphia, a twenty-four inch Foulis governor for regulating the delivery of gas to the street mains.

Gas making at the new station was commenced December 1, 1889, and has been in successful operation since that date.

The paramount endeavors in the planning and construction of this plant have been to avoid display and useless expenditures for outward effect and complication, and have been concentrated in producing the simplest and most effective methods for manufacturing gas of a uniform good quality at the lowest cost.

In these days, and days to come, in which competition is to be met, the best machinery is the cheapest and most profitable. In the matter of apparatus and methods of operation, while others may be as good, we may be pardoned, I think, in believing that our new Coal Gas Works is of the best, and is well provided to produce the most effective gas fuel, as well as the most practical medium of artificial light.

Discussion.

The President—Gentlemen, you have listened to this paper by Mr. Hyde, and I don't think any comment from the chair is necessary. I think the end has been reached in that works; and I trust a free discussion will be had on the paper.

Mr. Printz—The description given by Mr. Hyde of his works is very vivid, so much so that we could almost carry the the works in our eye, and we can tell about what the works would look like. What I would like to ask of Mr. Hyde is the results which have been obtained in the new works—whether they have been superior to those in the old works, in the amount of gas produced per ton of coal, and also as to the saving in the amount of coke used—that is, the percentage of coke that has been used to carbonize say 100 pounds of coal; whether the difference has been very marked between that formerly used in the old works and that used in the new works.

Mr. Hyde—As the acceptance of the Bredel benches depended upon their results, a test was made to ascertain the percentage of coke used. Four benches were run a week, according to the contract, on 19 per cent. of the coke produced. That was the trial. We have been running three months. Of course it is in the beginning of the work, and under the management of those who have not been accustomed to use this kind of bench, and with those benches (as any benches, or any new work in new hands) it is necessary to run for a while to get accustomed to the methods. The other day, my son, who has charge of the works, reported that, as near as he could make out, they ran a week with 22 per cent. Of course they didn't include in the first test an occasional stopped stand-pipe, and that interferes with the record which might be obtained where you are making a trial, the first trial especially. We feel satisfied that somewhere about that amount of coke will be required to heat the benches, 22 per cent. In the old works I have run with our plan of old benches for a month with 25 per cent., and I have run six benches for six months or a year with 27 or 28 per cent. It would seem from the information which I am able at present to present, that there is a saving of probably 5 or 6 per cent. in the use of the Kloenne-Bredel benches. What the future will develop will be the experience of the manager, and we do not know now. It may be less than that, but I apprehend that 22 per cent. is about what we may expect. Does that answer your question?

Mr. Printz—Yes, sir. Another question that I would like to ask—were not the old benches you speak of extraordinarily good benches, or good settings, for the old style? That 22 per cent. you speak of is much below what we usually hear from the old settings.

Mr. Hyde—As far as I was able to determine that, and I made many inquiries in years past, with reference to the consumption of coke, our experience compared with that of every other gas works that I inquired of, was such that I can scarcely believe my own statement, because everybody else said otherwise? I could not understand why we were able to keep our furnaces at the right heat with so small amount, when every other company varied from 40 to 50, even 60 to 70 per cent. of the coke produced. I couldn't understand how we were able to run six months with 27 or 28 per cent. under, you might say, unfavorable circumstances—like charging benches and having them ready for use, and holding them for dark days, etc. But we seldom got above 30 or 31 per cent. It always had been for a long time, rather a mystery as how it came—whether the others were careless in their statement or what it was. I knew I was making the statement, and I knew the information I obtained was correct. Mr. McIlhenny was at our works a year ago, where we were constructing a bench, and he said: "I see the philosophy of your benches now. I never could understand it. Your furnaces are short and narrow and others are long and wide." That was partly in confirmation of what I had ascertained myself at one time. About 15 years ago we got a plan from New York for the erection of a set of benches that called for a length of 42 feet furnace, I think, and 14 inches in width. That was the grate-bar surface. Mr. Christy, our superintendent of the works, and myself noticed they were much at variance with ours, and we said, "Now, ours are all right, and what is the use of having anything better?" But we concluded to set up three benches on the new plan, and built the other nine on the old plan. Then we set to work to see if there was any difference in the practical use of them. We tried them on coal and on coke. We ran long enough to demonstrate the practical use of them on each

kind of fuel, and the result was that with the new style we used about 2,000 pounds of fuel per day; while with the 3½ (I think it is something like that), and 12 inches wide, we used about 1,600 pounds. That would be three-quarters of the quantity, and we produce the very same heat exactly. We could not use less than 2,000 pounds with the wide furnace, and we couldn't use more than 1,600 with the other, but the heats were the same, and the quantity of coal carbonized in the retorts was the same. We also tried the coke, but I cannot give the quantity. The results, however, were the same, or about in that proportion. So we demonstrated, to a certainty, and gave an explanation why we were using less fuel than others. But I can't now see how any company could use up to 50 and 60 per cent. when we were using 28 or 30. While in Massachusetts I called at several places and asked of them the quantities, and also told them our experience. They looked at me as though "that would do for a western man to tell a down-easter; but we don't take any stock in it." I was astonished to find they used so much. What did they do with it? that is the question. Mine, you would say, was absolute measurement. We filled so many retorts with coal and pulled so many out. It is not measured, but the retorts are charged alike, and a certain proportion of them used, so there is no mistake about the quantity. I think I have answered the question.

The President—You got the same yield from the short and narrow benches?

Mr. Hyde—Just the same with the same charges.

Mr. Smith—Any difference in the depth of the furnaces?

Mr. Hyde—No, sir; constructed the same and fed the same; treated the same every way.

Mr. Printz—I don't wish to monopolize the time of the meeting by asking all the questions, but I would like to ask another, and that is—the size of the retorts in the benches, the amount of coal you were charging into them, and the yield you were getting from these new benches?

Mr. Hyde—Now?

Mr. Printz—Yes, sir.

Mr. Hyde—It was understood that we were to get 9,000 cubic feet to a retort. We have averaged from nine to ten thousand.

Mr. Printz—Now, the size of the retort?

Mr. Hyde—The retorts are 15 by 26, by 9 feet 4 inches.

Mr. Printz—Charged every four hours?

Mr. Hyde—Yes.

Mr. Printz—What weight?

Mr. Hyde—333 lbs. we are charging now. I think that is the highest—333, 316, sometimes 300, depending on the condition or necessity.

The Secretary—Mr. Hyde, what disposition do you expect to make of your old works? What will be their ultimate fate?

Mr. Hyde—There can be no change made in the old works, except to use them as they are.

The Secretary—Indefinitely?

Mr. Hyde—Indefinitely. That is, we do not see now any reason why we should lift the benches up and have a basin where the benches are. It is not convenient. The width is not right, and the probability is that we shall use them as they are. They are not extravagant in the use of fuel. We have not thought of it, but I don't suppose there will be any change.

Mr. Printz—One further question I would like to ask, and that is as to the care in the handling of these new benches. Is it necessary to draw the clinkers from the furnaces as often as you do in the old set?

Mr. Hyde—I wish I could tell you something about the running. I have been busy about other things. My son runs the works. I am satisfied of this, that there is economy, of course, in being able to draw your coke out of your retorts to run it down into the basement instead of hauling it off in some other way. The tendency is to economize; to what extent I am not able to say. I wish I could state that, but they are new to us and I have been busy about other things and have not paid attention to it so as to be able to answer.

The Secretary—After you make increases to a considerable extent, do you anticipate any trouble from back pressure thrown by these Bredel tar and carbonic acid extractors and ammonia washers?

Mr. Hyde—No, sir, we don't anticipate any difficulty in that respect. We calculate to run about eleven hundred thousand and when we get to that we will have another set.

The Secretary—What pressure do they throw now, with your make at 600,000 feet?

Mr. Hyde—It is eleven inches.

The Secretary—That is the aggregate pressure before the exhaustor?

Mr. Hyde—Yes, sir.

The Secretary—What pressure, for instance, does the ammonia washer itself throw?

Mr. Hyde—I could not tell you that. I only noticed the other day that it was eleven inches before the condenser.

Mr. Cantine—Why, if water gas plants are so good and generally used and so popular, why did Mr. Hyde not put that in a plant of that type instead of this 5,000,000 coal gas plant?

Mr. Hyde—We think a good deal of water gas, but we don't use it. As far as we have been able to ascertain we thought it safe to use the process that we were familiar with. We know we make gas at not a high price, that is we make it cheap, and the method and process we are familiar with and we make it with ease, and everything has been satisfactory so far. The question of introducing a water gas plant has occasionally been brought to our at-

tention and we think some time we will put in a set. However, if we don't put it in any faster than we talk, it will be some time; for we have talked about it for ten years. We bought the right to use the process about ten or twelve years ago. I am satisfied of this, that it would be well to have a plant, because in Cleveland, as in other places, we occasionally have a dark day, and when it is dark, it is dark. We have repeatedly, or about once a year anyhow, consumed all the gas we make between sunrise and sunset as fast as we made it, and our supply for the night is what we had on hand at sunrise. So, if that day should be repeated we would be floored. In an emergency of that kind I think it would be desirable to have a water gas apparatus so that when we found the day was going to be dark we might commence making water gas to replenish. But from all we have been able to find out or learn, we have not decided to change yet, any way. We have got coal gas yet.

Mr. Evans—I would like to ask Mr. Hyde to state how much his gas costs him in the holder?

Mr. Hyde—That is a question that I could not answer before any public assembly.

The Secretary—I would like to ask Mr. Bredel, who is now present, the question I asked Mr. Hyde, as to what pressure his ammonia washers throw with that 600,000 feet daily make?

Mr. Bredel—All the way from three to five inches pressure.

The Secretary—Isn't that a good deal?

Mr. Bredel—No, the exhauster will take care of it all. You will have to push your gas so much harder. I don't see any objection to high pressure. I know of gas works where the pressure is up as high as 14 or 15 inches, and I don't see the objection to it.

The Secretary—As I understand it, your purifying boxes don't throw any pressure at all.

Mr. Bredel—No.

The Secretary—But after the make increases materially I should think these purifiers would throw the usual pressure, which is considerable, and then your aggregate pressure, it seems to me, would be rather high.

Mr. Bredel—Well, it might be that the purifiers afterwards will throw about an inch pressure. If they throw more there is something wrong. Your purifier is not large enough, or your purifying material is not good.

Mr. Printz—I would like to ask Mr. Hyde if that saving of five per cent. in the coke is sufficient to justify the extra expense incident to the cost of this Kloenne-Bredel furnace over the old settings?

Mr. Hyde—Well, I have not taken that into consideration. In investigating this matter of putting in the new works we concluded that we would have in a set of these benches for trial, but I have not investigated. After we get fairly going and have run several months, we shall settle all that conclusively. I, however, may say this, we expect to extend our retort house and put in the same kind. We expect this year to extend the retort house 500 feet, and expect to build a tank of 145 feet in diameter for the same works. We are contemplating the need of further extension.

Mr. Printz—I would suppose that there is not only this saving of five per cent. in the fuel, but the advantage which you obtain by the setting, in the handling of your coal and getting rid of your coke, would certainly be quite an inducement to make a change of this kind.

Mr. Hyde—Yes, sir, we expect that; but you asked a definite question, and I can't answer it. I would be pleased to if I could. Of course we expect to get benefit from the use of this or else we would not think of extending it.

The Secretary—With us the price of coke is so low that the study of the economies in coke saving is not a matter of any particular importance. Our coke nets us only 3½ cents, and although our regenerator furnaces consume more coke than they ought, we don't care very much. We use at least 30 per cent. of the coke we make in the furnaces.

Mr. Printz—One of our bashful members requests me to ask the price which Mr. Hyde gets for his coke.

Mr. Hyde—The ordinary price is seven cents for the coarse coke. For our crushed coke we get 8½ cents at the works.

Mr. Faux—Do you not expect your retorts to last much longer than under the old system of firing?

Mr. McIlhenny—I believe the usual way of measuring the life of a retort is by the quantity it produced during its life. If a retort is run hard and produces in a year five million feet, and another runs three years and only produces the same quantity, the one that runs a year has done as much work as the other one. It is a question of production rather than a question of time.

The President—That is undoubtedly true, but the factor comes in there, however, whether the one system maintains a more uniform heat than the other. I think we will all agree that that system that maintains the most uniform heat, even if it be somewhat higher heat, would perhaps be not more destructive to the retort than a lower and vacillating heat.

Mr. McIlhenny—Yes, of course. The regenerator system is like running a train without stops at stations. You don't have to stop and start the train again. You draw the hot coke into the furnace, and there is no cooling of the retorts by the cold coke being thrust in. Now you have a practical advantage in that direction, I think. You have a more uniform heat, of course, upon the bench, and better results. Besides, we all know that all kinds of material contract and expand more or less by heat and cold, and when you cool your bench down by throwing in cold coke there is more or less

contraction of the retort, and it takes some fuel to bring that heat up again to the condition the regenerator should maintain.

Mr. Faux—The reason why I brought out that question was this: I use natural gas. Three years ago when I took charge of the works, there were benches that had been dismantled and torn out. The retorts were good but they wouldn't heat with coal and coke any more. I refitted them, put natural gas under them and have run them now three years, and I find they are in very good condition. The reason I brought that out is to show that with the regenerator furnace and firing by gas, the life of a retort is much longer than by firing the old way. I believe in gas firing under a retort.

Mr. Bredel—Mr. President, I think the injury is due more to the solid pieces of coal that get in the ordinary furnace and, coming in contact with the retort, form a flux there and make the retort crack. Now in the regenerator furnace no flying ashes or anything can get into the retort and form a flux, and, as Mr. Faux says, naturally, this is an advantage in firing with gas. Another thing, if you open your filling door, there is not much chance for cold air to get in. Of course if any cold air gets in it will have to pass through the generator and will be warm by the time it strikes the retort and will not crack it.

The Secretary—Mr. Bredel, what is the proper temperature in your regenerator furnace when it is working right?

Mr. Bredel—That is a pretty hard question to answer. The proper temperature of the furnace itself, of the fuel, should not be much hotter than the coke coming out of the retort. In attempting to estimate this I use an apparatus of my own contrivance for that. You cannot call it a pyrometer, but I have used it quite satisfactorily. It is a very simple arrangement, but it is only for comparative heats. I take a small box and make little slots in it and take blue glass and cut them up into pieces of one inch square and put 20 to 30 in it. Then bore a little hole on both sides, about half an inch in diameter, look at the fire, and put so many blue glasses on until I can't see anything more. Then I rate by how many glasses it takes. In this way I have a comparative test.

The President—In the matter of economy in firing, the regenerative furnace has one advantage that I have not heard brought out yet, and it strikes me that it is much greater than many of us are perhaps apt to give it credit for, namely, the fact that the fuel is dropped in at the top. Of course there would be no current of air in that case, as with a door opening squarely in front. In the latter case you get a current of air through the ordinary furnace, that means a good deal of disaster. Of course every time the door is opened for stoking or charging or anything of that sort a current of cold air rushes in. I have no doubt the difference is very much greater in that regard than many of us think.

Mr. Hyde—I would like to make mention of a scheme that I have in mind. Whether it will ever be carried out or not at our works I don't know. In perfecting our method of handling coal and coke at our new works my scheme is to shovel the coal into a car from the coal shed, where, of course, it is unloaded; lift the car and dump it into a crusher for crushing it for the steam charger. It would pass through the crusher into another car. That car would be lifted high up into the retort house, and run around on the tracks on each side of the house to the dumping bins. Out of these bins the coal would be drawn into the steam chargers and be blown into the retorts. Then, after carbonization, withdrawn by steam with the steam stoker, and drawn into the chutes in front of the retorts down into the coke car—that car to run along on a track to an elevator, and be lifted and dumped into a bin; the coke drawn out of that bin over a screen that takes out the dust, and continuing a little further, takes out the pea, if you choose, then the nut and the dust and the pea are deposited in separate bins, and the coarse coke will run into a car. One shoveling in the works, after the coal is unloaded into the works, does the whole business. We have no track at present for delivering the coal into these bins, and have no bins as yet. But that is what we are thinking of doing, and if we do, one shoveling will do the whole work.

Mr. Dittmar—Mr. President, since we are on the different modes of manufacturing gas, and manufacturing it quickly, I want to ask Mr. Hyde whether he fully looked into the matter of the various processes of manufacturing before spending the amount of money he did for manufacturing coal gas?

Mr. Hyde—Only in a general way. Of course almost any one is familiar with the method of making gas by the water gas process. But we didn't go into that particularly. We had in view having a coal gas works, and we did not investigate perhaps thoroughly with reference to all the other methods.

Mr. Dittmar—As I understand you, you anticipate putting in a plant for making gas quickly. Did I understand you rightly?

Mr. Hyde—No; we expect to extend our present method.

The President—I think Mr. Dittmar partially heard what Mr. Hyde said with reference to water gas processes. Mr. Hyde did say they had had under consideration the matter of water gas, but that if they made progress as fast in the adoption of water gas in the future as in the past, it would likely be a good many years before it was put into operation—or something of that kind.

Mr. Dittmar—I judge, then, from that remark that Mr. Hyde is not very much impressed with these different processes of water gas manufacture.

Mr. Hyde—Well, I cannot say. You might draw that inference. We have not yet concluded to put in a water gas plant.

On motion, a vote of thanks was extended to Mr. Hyde.

(To be Continued.)

[Communicated Article.]

Doubts Versus Dogmatism.

By MR. B. E. CHOLLAR.

At the meeting of the Western Gas Association, held in St. Louis, in 1887, the writer read a paper on "The Rule of Inverse Squares," in which he endeavored to show, by a simple geometrical demonstration, that the commonly accepted law of light, as applied in the practice of photometry, exaggerates the value of a small light to the consequent disparagement of a larger one.

The paper, although prepared with some care, was intended by no means as an elaborate effort, but, on the contrary, was offered as an invitation to our scientific friends to take up the discussion of the subject with a view of clearing away the very serious doubts in the minds of many in regard to the truthfulness of the photometer.

It is unnecessary to say that the paper failed of its object. The criticisms were few in number and extemporaneous in nature. The general inference seemed to be, however, that the writer might possibly engage in a more suitable occupation than in that of questioning natural laws as they are laid down in the books.

The paper was disposed of in short order: but the doubts still survive. And the doubters persist in believing that a big light has some sort of an unrecognized value not possessed by a little one.

Where there is much smoke there must be some fire. Let us look again for the fire.

We will suppose a luminous point, trace an imaginary beam of light from it through a series of ideal lenses and note the result.

Although in reality it is altogether probable that there can be no such thing as a "ray" of light; yet the conception is correct, and the expression is so intelligible and convenient that we will make use of the term.

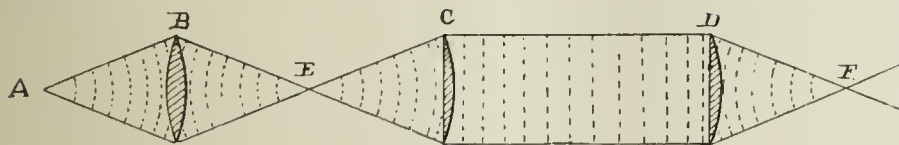

In the diagram let *A* represent the luminous point, situated in one of the conjugate foci of the lens *B*. The effect of the lens upon the light received by it will be to change the direction of the rays and converge them at *E*, which point we will make the principal focus of the lens *C*. At *E* the rays will cross without change of direction and diverge to *C*, where they will again be changed in direction and made parallel, in which relation they will continue until, by the lens *D*, they will be directed to the point *F*. The general form of the wave point of the diverging rays, from *A* to *B* and from *E* to *C*, will be convex in the direction of the light, while that of the converging rays *B* to *E*, and from *D* to *F*, will be concave. From *C* to *D*, the light rays being parallel, the successive wave points will be parallel planes. If, therefore, the light from the luminous point *A*, advancing with a convex wave point, decreases in strength in proportion to the square of the distance, it follows, conversely, that light from the surface *B*, toward a point or with a concave wave point, must increase in strength at the same rate.

Similarly, light made up wholly of parallel rays should neither increase nor decrease in strength.

Here we have severally—if the expression may be permitted—three distinct kinds of light; one of which decreases, another increases, while the third remains constant in strength as the distance increases. A luminous point can emit only the first, while a luminous surface sends out all of the three kinds of light, only one of which diminishes in proportion to the square of the distance.

The other two kinds alone possess the characteristics of what we call diffused light. Diffusiveness in light, therefore, is a quality produced by converging and parallel rays; hence if these rays are not governed by the law of inverse squares, diffused light is not; and it follows, in comparing a large light with a small one, that the photometer is a prevaricator.

The mendacity of the photometer lies in the scale graduated on the bar, and the law under consideration can be proved true by the photometer itself no more than a tape line can be proved correct by measuring backward over a distance already measured by the same tape.

It is well to be precise; but it is better to be correct. And it is hardly worth our while to spend time in looking for a light-standard of third decimal place precision, so long as the photometric bar may possibly be wrong in units.

In the meanwhile it appears to the doubters that the larger light is entitled to a credit over the smaller by reason of its size, and independent

of its brightness. In other words, that photometer experiments, as they are ordinarily made, should be corrected by an addition to the observed value of the larger light.

The Influence of an Idea.

The *London Journal*, in its issue for March 18, says that a curious illustration of the influence of a fermenting idea is to be observed in the progress of the improvement of gasholder design by the suppression or radical modification of the guide framing. It is some time since we devoted any space in the *Journal* to a review of this modern improvement, and meanwhile the change that was a few years ago regarded by most engineers as chimerical, has become a commonplace of engineering, as our advertisement pages testify. It will doubtless require time for all gasholder makers to fall in with the new movement, especially as the two best known arrangements for dispensing with the outer guide framing of gasholders are proprietary. Contractors who do not possess workable patents of this class will naturally disparage their value, in order to keep work in their own hands; but the commercial future of this reform in the principles of gasholder construction will settle itself. We have nothing to do with this part of the question, but desire for the present merely to call attention to the remarkable practical effect that a single idea has wrought in this branch of engineering; and we do this not for the sake of unduly magnifying the value of this particular idea, which may be great or small, but in order that any reader who may at any time start a similar idea may be encouraged. In most professions, and particularly in gas engineering, there exists a robust class of critics who claim to be nothing if not "practical." They weigh everything in the same balance, and pass ideas over their weighbridge just like trucks of coal. Anything by way of suggestion that cannot be weighed in this fashion, and its value determined forthwith in current coin, they dismiss as "theoretical"—which in their mouths is a term of contempt. These critics are eminently respectable and useful in their way; but it is well to occasionally remind them and the world that they do not know everything. There are matters which cannot be weighed on a weighbridge, or measured by a two-foot rule, but which may in the fulness of time set many weighbridges and rules to work. These are fundamental ideas. Nobody can tell for certain, when a strange suggestion arises in his own thought, or is communicated by his neighbors, whether it is likely to bear fruit or not. Technical journals and the records of the Patent Office bear witness of many suggestions that never come to anything. There is no recognizable hall mark on these productions of the mind. Not even their parentage serves to indicate their value; for the most striking thing about the life work of every eminent man is the amount of suggestion which he produces to waste. A Siemens or a Bessemer, whose ideas sometimes create new industries, make more failures than successful shots; so that not even the best accredited ideas can be accepted without practical test. On the other hand, the most obscure thinker may discover a clue to an industrial advance that has escaped others. It is his duty, therefore, to give his ideas a fair chance of being heard; and fortunately the means of publication are so generally available now-a-days, that nobody need despair of a hearing for aught he may have to say that is not obviously ridiculous.

The distinction between a fertilizing idea and its practical application is radical. The idea may be expressed in a few words; but the application may take years in working out. The property in the original suggestion and in its utilization may, and generally does belong to different people. Sometimes, but happily not always, the first discoverer essays to protect himself from the improver by patenting every imaginable modification of the embodiment of his idea; and when he has overlooked a weak spot that is taken advantage of by another, he is loud in his denunciations of the infringement. It is probable that more general good is effected when the discoverer keeps himself independent of the practical deviser of applications, whose genius is of a totally different character. We say this because it is possible that here and there may be found men who have in their minds more or less clearly defined ideas on various industrial problems, which they are not disposed to publish for what they are worth because they have a half-wish to keep them until they can clothe them in working shape. This day never comes. The man with the idea never succeeds in devising the practicable embodiment for which he waits; and so his idea perishes with him. It is not always that he keeps his idea to himself with a view to his personal gain. Such conduct would be undoubtedly selfish and short sighted, but not necessarily iniquitous. It may well be, however, that the man with the idea does not keep silence through selfishness, but simply through modesty. He has the idea, such as it is, but cannot himself see

what practical good it represents, and has no hope of acting upon it. He is afraid of the robust practical critics already referred to, who are sure to "sit upon" him for venturing to dabble in a "theory" which has no apparent connection with their experience; and so he keeps his own counsel, and the world is the poorer of a suggestion that somebody else might have been able to work up into a useful shape.

It will not perhaps be an undue exaggeration of the worth of the example if we cite the history of the movement for the suppression of gasholder guide framing of the usual description, in support of the foregoing observations. About this time three years ago there appeared in the *Journal* an article entitled, "Is Lofty Guide Framing Necessary for Large Gasholders?" which began with the statement that "the question as to what is the precise value of gasholder framing is one that has been raised several times by engineers with a propensity for diving after abstract principles of construction, but has not yet been settled, or even placed upon the road that may lead to settlement." The gist of the article lay in a suggestion that a gasholder might be maintained in a proper working position by means of the bottom curb. It was the first promulgation of the idea of guiding gasholders from the base. And now let us pause to point out that this was no more than an idea, stated simply for what it was worth, without any attempt to apply the principle. The time was apparently favorable for the suggestion, although there had not been any prior discussion of the subject. Within the week, Mr. V. Wyatt came forward to admit the force of the suggestion, and wrote the truly remarkable words for the time: "I quite anticipate the production of a self-sustaining gasholder in the future." The fulfillment of this prophecy at Northwich and Haslingden by two different methods of gasholder guiding not then thought of, is one of the most interesting developments of modern gas engineering. It is unnecessary to do more than mention the work of Mr. George Livesey in this connection; but his remarks on the original suggestion are instructive, in view of accomplished facts. He said: "If some practicable means could be devised whereby all the bottom rollers might be made to rise or fall equally, and none of them could either rise above or fall below the others, the holder would then, to all intents and purposes, have a solid foundation, and no columns or guide framing of any kind would be necessary." Mr. Harry E. Jones and Mr. F. D. Marshall must also be included among the few who realized the speculative value of the idea expounded in the *Journal* article; while nobody could say that he was satisfied with the only suggestion then offered for embodying the principle. Time passed; Mr. W. H. Y. Webber's paper was read and discussed at the Glasgow meeting (1887) of the Gas Institute; and still the idea remained "in the clouds," although an increasing number of engineers came to think there was "something in it." Months afterwards, the idea showed signs of bearing fruit. Mr. W. Gadd was first in the field with a printed device for maintaining the verticality of holders without lofty guide framing; Mr. Pease perfected a different means of attaining the same end; and the list of inventors who sought to solve the practical problem in various ways includes at least half a dozen other names, and might probably be largely extended. All this simmering effort, be it understood, followed the publication in these columns of a thoroughly unpractical "notion," which the original promulgator has never attempted to convert into an actual fact. In all probability the coming summer will witness a noteworthy expansion of the trade in gasholders without external guide framing. Which will be the favorite system to be followed in this and foreign countries, is not for us to anticipate. Whether the known devices will be supplemented or superseded by others, is another question that must be left to the future to answer. At any rate, an economy of about 30 per cent. in the cost of a holder is something that no conscientious gas manager, duly solicitous for the rightful application of his employers' capital, can affect to ignore. The revolution in gasholder design has been effected; and those engineers and contractors who are specially interested in the new departure will have plenty of work from this time forward. The men who have made the new principle workable in despite of all the opposing forces of ignorance, apathy and prejudice, deserve all the reward they will get.

In concluding this short notice of the origin and present position of the most striking reform in gas engineering practice that has been brought to pass since the existing type of gasholders was adopted, we repeat that our main object has been the encouragement of the expression of ideas by those who entertain them, irrespective of their apparent value, in a practical sense, at the time. It is not necessary to define the limits that separate from mere dreams those suggestions which have possibilities of usefulness. The line need not be drawn too closely, for the dreams of some men are worth more than the waking sense of others. Ideas relating to industrial developments are not more fre-

quently of the nature of dreams than many of the political projects that fill the daily newspapers; and it is hard to see why an engineer as well as a politician should not be allowed his occasional flight of fancy.

Professor Wolcott Gibbs on Illuminating Gas.

Professor Wolcott Gibbs some evenings ago delivered a lecture on illuminating gas before the Business Men's Association, of Newport, R. I. There was a large attendance of members and invited guests, among the latter being Professor Munroe, Major Livermore, Dr. C. A. Brackett, A. B. Almon, Colonel E. M. Neill, John Whipple, A. B. Emmons, E. P. Allan, W. E. Dennis, C. E. Hamnett, Jr., J. G. Topham, Dr. H. R. Storer, Rev. Mahlon Van Horne, James S. Bryer, Rev. Warren Randolph, W. A. Barber, G. P. Taylor and Captain H. B. Ryder. Mr. L. D. Davis, First Vice-President, was in the chair. The lecturer introduced his subject by giving the following figures showing the analyses of the average coal and water gas in use in Massachusetts:

	Coal Gas.	Water Gas.
Marsh gas.....	38	21
Hydrogen.....	47	32
Carbonic oxide.....	6	27
Illuminants	5	15
Impurities.....	4	5
	100	100

And then went on to say that marsh gas is a colorless, odorless and tasteless gas; not poisonous, but capable of producing death by suffocation. Hydrogen is also a gas, tasteless, odorless and colorless; not poisonous, but producing death by suffocation. It prevents the blood from being oxidulated. Carbonic oxide is a colorless gas, nearly or quite odorless, but is deadly poisonous. The illuminants are sometimes 2, 3, or 4 in number, and are very important in the manufacture of either gas, as without them the commercial qualities of the gases would be of little consequence. The impurities are composed partly of carbon dioxide or carbonic acid. They are of no great consequence, but are necessarily present from the nature of the materials used in the making of gas. Marsh gas, hydrogen and carbonic oxides burn with a very pale light, which makes them of little value in commercial use in the composition of illuminating gases. It therefore becomes necessary to have something to afford illuminating qualities. In some of the larger manufacturing of gas, oil is used to give a larger proportion of illuminating power. Passing hurriedly over the manufacture of coal gas, the speaker said that the manufacturing of water gas is one of the most beautiful processes in manufacturing chemistry, its simplicity exciting the admiration of experts. Coal or coke is heated to a high degree of temperature by means of air blasts and then a jet of steam is forced over the heated substances and decomposes into hydrogen and carbonic oxide, the gas being collected and cleaned. Pure or simple water gas is composed almost entirely of hydrogen and carbonic oxide, but this is of little value as an illuminant. The lighting qualities are imparted to it by the introduction of petroleum or naphtha. The process is simple; the plant occupies but a small space and requires little scrubbing or cleaning. It must be very cheap. But there are no side products as in the manufacture of coal gas. In the latter the coke, ammonia water and coal tar are of a considerable commercial value. The coke is used for heating purposes; from the ammonia water nearly all the ammonia used in the arts is obtained, and from the coal tar the hundred or more aniline dyes are produced. In taking into consideration the cost, the value of these side products is of much importance, yet the speaker thought that the fact that so many gas companies are using water gas shows conclusively that the manufacture of that gas would be much less expensive than that of coal gas.

Professor Gibbs devoted a large portion of the lecture to the consideration of carbonic oxide. This is usually admitted to be one of the most, if not the most, poisonous of gases. It is directly poisonous, acting upon the blood corpuscles, displacing the oxygen and taking its place, and thus paralyzing the corpuscles. He then read Sir Humphrey Davy's experiment of the effects of carbonic oxide upon himself, and those of Messrs. Nichols and Sedgwick, of Massachusetts, and of German and French chemists, which had been to determine the amount of the gas necessary to produce death. These experiments have shown that the presence of one-half of one per cent. of carbonic oxide is exceedingly dangerous, and will almost inevitably produce death. The experiments of Messrs. Sedgwick and Nichols were also directed to determine what per cent. of air will be displaced by a gas in a commonly ventilated room, where it is not absolutely air-tight. It was found that the air of such a room will contain $3\frac{1}{2}$ per cent. of gas. Taking his

table mentioned in the beginning, Mr. Gibbs showed that in the case of coal gas, which contains only 6 per cent. of carbonic oxide, the 3½ per cent. of this amount (.21 of one per cent.) is far below the danger limit; while in the case of water gas, 3½ per cent. of its proportion of carbonic oxide (27 per cent.) leaves a presence of .95, or nearly one per cent. of the poisonous gas, which is far above the danger limit.

The return petition before the Legislature for a law governing the amount of carbonic oxide in illuminating gas was for the purpose of keeping the proportion of obnoxious gas below the danger limit—10 per cent. In an analysis of the gas in use in Newport a few weeks ago the proportion of carbonic oxide was found to be 9¾ per cent., which is less than the required limit; the local company using a mixture of coal and water gas, which reduces the proportion of carbonic oxide. Mr. Gibbs said that coal gas and water gas in use as illuminants are both detectable by the odor, which is produced by the illuminants and impurities. The danger of the gas is from its escaping from the fixtures, which are not always tight, from carelessness in turning off the light and leaving the gas to escape, in the dropping out of the stoppers, and from the breaking of mains in the streets. The last is the most dangerous of all, as it has been found that in the passage of the water gas through the earth the gas is purified and loses its odor, so that it may come into our cellars and its presence be undetected until it affects our health. The dangers from the leaks of the common water gas are more pronounced than from coal gas, because of the presence of a greater proportion of carbonic oxide. There is no difference in the explosiveness of the two gases—that is, one will not explode more quickly than the other; but the water gas is more violently explosive than the coal gas, from the fact that the former contains more illuminants than the latter, and this causes the greater violence of the explosion. It is claimed that coal gas exhausts air much more quickly than does water gas. The products of combustion are the same in both, and about as much oxygen is required by one as by the other, and the difference in this respect is not worth noticing. In conclusion, Mr. Gibbs said that the State fixes the danger limit in kerosene and illuminating oils, and that it could take the same action in regard to gas.

At the conclusion of Professor Gibbs lecture Mayor Coggeshall spoke briefly in defense of the Newport Gas Company, saying that it did not desire to provide a dangerous gas for its consumers. He spoke of the advantage of public discussion. He was in favor of water gas, which he believed to be the coming illuminant.

ITEMS OF INTEREST FROM VARIOUS LOCALITIES.

MR. WM. JOHNSON, for many years a collector in the employ of the Fuiton-Municipal Gas Company, of Brooklyn, N. Y., is dead. He was a faithful man, and much esteemed by his employers.

THE following action of Mayor Barker, of Providence, R. I., in respect to the proposed chartering by the Legislature of that State of the Wakefield Manufacturing Company, goes to show that the local authority is alive to the slight which would be put upon them in the event of the passage of the measure. The documents explain themselves:

CITY OF PROVIDENCE, EXECUTIVE DEPARTMENT, }
CITY HALL, March 27, 1890. }

Gentlemen of the Board of Aldermen: I have convened you to-day in order to present a message in relation to a proposed act of incorporation of the Wakefield Manufacturing Company now pending before the General Assembly of the State of Rhode Island.—Henry R. Barker, Mayor.

CITY OF PROVIDENCE, EXECUTIVE DEPARTMENT, }
CITY HALL, March 27, 1890. }

Gentlemen of the City Council: An act of incorporation has recently been presented in the General Assembly by which it is proposed to give to the Wakefield Manufacturing Company authority to produce, make, generate, sell, use and supply gas in the city of Providence for lighting, heating, mechanical and other purposes, etc. Section 4 of said act provides that "said corporation upon filing its bond in said cities of Providence and Pawtucket, in the sum of \$25,000, with the Treasurer of said city or cities to secure the putting of the streets of said city or cities, wherein it may choose from time to time to exercise the powers to it granted by this act, in as good order as said streets and highways were in at the places wherever said corporation may do work at the time of commencing work thereon, may open the ground in any part of said streets or highways for the purpose of laying, putting in and down and repairing pipes and other appliances for the use and the conducting of gas, and for any other purpose necessary or incidental to or convenient for the exercise of the powers granted by this act." It will be seen by

the provisions contained in this section that this Company, if the act is passed, will obtain the right to use any of the streets in which it may determine to lay and use its pipes without any control thereof being had by the City Council, either as to the streets used or the manner of their use. Deeming that such broad and extensive grants should not be conferred upon any corporation proposing to do business in this city without making it subject to such proper restrictions and limitations as the City Council may impose, I have brought the matter to your attention in order that you may take such action thereon as may by you seem best.—Henry R. Barker, Mayor.

THE following is extracted from the annual report of the Halifax (N. S.) Gas Light Company: The net income for the year was \$24,092.52, and the total expenditure on all heads was \$72,721.41. The following is a recapitulation of the balance sheet to Jan. 31, 1890:

Capital stock	\$400,000.00
Amount due by Company to wear and tear and contingent account	196,426.00
Dividend, payable April 1	12,000.00
Profit and loss account	15,493.00
Total	\$623,919.00
Gas works, etc., meters, materials, coals, electric light station and materials	590,754.00
Cash on hand and due Company	39,165.00
Total	\$629,919.00
<i>Profit and Loss.</i>	
Dividend, paid Sept., 1889	12,000.00
“ payable April, 1890	12,000.00
Balance carried forward	15,493.26
Total	\$39,493.26

FROM a local source we learn the following respecting the situation at St. Louis in the matter of the proposed 90 cent gas rate: "Interesting developments are expected after the 90 cent gas rate bill goes into effect, at noon of to-morrow—March 29. The bill, as probably your readers are aware, makes it a misdemeanor for any Gas Company in the city to sell gas at more than 90 cents per 1,000 cubic feet; and as the Laclède Gas Light Company, through President McMillin and Vice-President Thompson, has announced its intention to maintain the present rate (\$1.25), it is probable that Mr. McMillin, as President of the Company, will be arrested on charge of violating a city ordinance; and if this is done, St. Louis will likely be the center of some interesting lawsuits. When Mr. McMillin was interviewed by a local reporter (on March 27), that gentleman said the Laclède Company had not yet fully decided what action it would take to prevent the enforcement of the new law, but he said that one thing was positive, which is that the Company would not make the reduction called for in the ordinance. He did not think the Company would decide to take action in the matter immediately after the bill becomes a law, as there was no hurry. The Company will not collect from consumers for about a month, and the time for the collection of the rates after the 90 cent gas bill is in force will be time for action. What the Company would do would be the result of mature deliberation. It is probable that the citizens who object to the payment of the present gas rate will be the first to declare war, although the fact that one of the officers of the Company may be arrested on the charge of committing a misdemeanor under a city ordinance may induce the Company to bring matters to an immediate crisis, and not wait for the action of the city or the citizens. Regarding the reduced gas rate bill, Mayor Noonan said: 'The fact that I did not favor the provisions of the bill and vetoed it when sent to me by the Assembly will not deter me from doing my duty, which is to see that city ordinances are enforced. I do not know what my first step will be, as I do not know what turn circumstances may take, but I will instruct Counselor Bell to look after any cases arising in the courts out of the matter, and I may send instructions to the police. The reduced gas rate bill becomes a law on the 29th, and it is my duty to see that the law is observed. I will not stand passively by because in my opinion the bill was not equitable, but will see that every step is taken to insure its observance.' City Counselor Bell said: 'As City Counselor of St. Louis it is my duty to attend to all litigation arising from the non-observance of the city ordinances, and when the reduced gas rate bill becomes a law it will be my duty to insist upon its observance as energetically as any other. What steps I may take will be decided by the instructions I receive from Mayor Noonan, and the turn of affairs after the bill becomes a law. However, I do not expect to take the first steps in the matter. The Laclède Gas Company will

doubtless take out a writ of injunction to prevent the enforcement of the city ordinance relating to the reduction of the gas rate to consumers, pending litigation to have the ordinance declared illegal and invalid. This I conceive will be the only step that will prevent a more unpleasant and summary course of proceedings on the part of the city. If the Company does not take out an injunction, but, nevertheless, persists in charging the present rate, even after the new law has gone into effect, one of the officers may be arrested on a charge of misdemeanor, and the litigation commenced in this wise. As soon as the reduced gas rate becomes a law it will be enforced."

THE proprietors of the Stoughton (Mass.) Gas Company have announced a reduction in gas rates, from \$6 to \$4.95 per 1,000. The Company manufactures a "high candle power pure oil gas."

IN the Manufactures Committee, Massachusetts Legislature, many matters of general interest to the fraternity have either been considered or are under consideration during the present session of the Legislature.

THE Committee on Finance, Milwaukee (Wis.) Council has wisely adopted a resolution "indefinitely postponing" consideration of the resolution appropriating a certain sum for the purchase by the city of an "experimental electric lighting plant."

AT the annual meeting of the Middletown (Conn.) Gas Light Company the following officers were re-elected: President, A. B. Calef; Secretary and Treasurer, F. E. Camp; Superintendent, J. H. Jones.

THERE is every indication that at the annual meeting of the shareholders in the Montreal (Can.) Gas Company a proposition will be indorsed that will increase the capital stock in the sum of \$500,000. The sum thus raised is to be devoted to paying for plant betterment and extensions.

THE Select Council of Philadelphia has negatived the proposition to raise \$250,000, the said sum to have been expended in the installation of a municipal electric lighting plant.

WE understand that Chas. P. McGuire and associates have signed their names to an acceptance of the fuel gas charter recently passed for them by the authorities of St. Joseph. Under its conditions McGuire & Co. were allowed 25 days in which to accept the franchise, and an additional 60 days in which to file the bond of \$20,000 as a guarantee that the work be undertaken under the stipulations imposed.

MESSRS. R. D. WOOD & Co., of Philadelphia, will build the new gas-holder for the Citizens Gas Company, of Newark, N. J. We understand that its capacity is to be 400,000 cubic feet.

THE new plant of the Duluth (Minn.) Gas and Water Company, at Rice's Point, is completed.

WE obtain the following from a Newark correspondent: "Mr. Dusenbury, Secretary of the Newark (N. J.) Gas Company, when appealed to for information concerning the rumors that Mr. Vanderpool's present trip to Europe was to make arrangements for the sale of the Newark Company's plant to an English syndicate, said: 'It is not true that our Company contemplates selling out to a syndicate, nor are making any negotiations for that purpose. Some little time ago we were approached by a representative of an English syndicate with a question whether we would name a price for our concern. The reply was given that the concern was not for sale, and that no price would be named. Since that time the negotiations, if they could be called such, were entirely broken off. The visit of Mr. Vanderpool, our President, to Europe has nothing to do with this business. Mr. Vanderpool goes to Europe simply because this is a time when he can go conveniently. The objects of the trip are two-fold. One is that he goes for recreation, as he is a very hard working man; the other object is to inform himself in regard to all the new processes and discoveries in the manufacture of gas, and to see all the new appliances for the use of gas, such as stoves, burners, etc. This last is especially in view of the fact that we are putting a new show room in the rear of our office building, which is especially designed for the exhibition of stoves, burners and gas apparatus of all descriptions.' President A. A. Smalley, of the Citizens Gas Company, whose interests are, to say the least, in no wise inimical to those of the old Company—also said: 'No negotiations for the sale of the Citizens Gas Light Company have ever been made or proposed. No offers to sell have been made by us nor have any propositions for purchase been received. The Directors have no power to sell or to agree to sell without

the consent of the stockholders. No proposition has been made or advanced in any form for a consolidation of the Citizens with the Newark Gas Company. Neither Mr. Vanderpool, Mr. Murphy, nor anyone else at home or abroad, is authorized to represent the Citizens Company in any relation whatever."

GENERAL HICKENLOOPER says that there is not a word of truth in the recent statements circulated in Cincinnati to the effect that the Cincinnati Gas Light and Coke Company is interested in the fortunes of the local branch of the Thomson-Houston Electric Light Company.

THE following is the full text of the bill now before the Rhode Island Legislature, to charter the Wakefield Manufacturing Company, which seeks to supply and sell gas in the cities of Providence and Pawtucket:

Section 1. Charles H. Henshaw, J. Edward Addicks, Samuel Little, Michael M. Cunniff, Spencer Borden and their associates and successors and assigns are hereby created a corporation by the name of the Wakefield Manufacturing Company, for the producing, making, generating, selling, using and supplying gas in the cities of Providence and Pawtucket for lighting, heating, mechanical and other purposes, and also for the purpose of manufacturing, using and dealing in all machinery, lamps, pipes, apparatus and appliances pertaining to the use of gas, and also with power to purchase, own, hold and dispose of shares of the capital stock of corporations in this State and other States, and bonds and other securities of such corporations, provided, however, that nothing in this act contained shall be so construed as to authorize said Wakefield Manufacturing Company to carry on a banking or stock brokerage business, and for the purpose of transacting any other business connected with the purposes and powers herein authorized, with all the powers and privileges and subject to all the duties and liabilities set forth in chapters 152 and 155 of the Public Statutes, and in the statutes and amendments thereof and in addition thereto.

Sec. 2. Section 2 of said act shall be amended so as to read as follows:

Sec. 3. The capital stock of said corporation shall not exceed \$5,000,000, to be paid in amounts from time to time, and divided into such number of shares, the par value of such shares to be fixed and the transfer of such shares to be made in such manner as the corporation may, by vote of its by-laws, determine.

Sec. 4. Said corporation, upon filing its bond in said city of Providence or Pawtucket in the sum of \$25,000 with the treasurer of said city or cities, to secure the putting of the streets and highways in said city or cities wherein it may choose from time to time to exercise the powers to it granted by this act in as good order and condition as said streets and highways were in at the places wherever said corporation may do work at the time of commencing work thereon, may open the ground in any part of said streets or highways for the purpose of laying, putting in and down and repairing pipes and other appliances for the use and the conducting of gas, and for any other purposes necessary or incidental to or convenient for the exercise of the powers granted by this act.

Sec. 5. Said corporation shall have an office or place of business in the city of Providence, and there shall be an annual meeting of the stockholders in the city of Providence at such times as the by-laws shall prescribe for the choice of officers, and for such other business as may come before them, and this act shall take effect from and after its passage.

AT a meeting of the stockholders of the Terre Haute (Ind.) Fuel Gas Company the following Directors were elected: Messrs. R. S. Tennant, J. R. Kendall, C. M. Warren, H. P. Townley, W. Kidder, A. Z. Foster and Capt. J. B. Archer. The proprietors assert that their preliminary tests with the plant have answered all expectations.

THE Caloric Light and Fuel Company, to do a general lighting and heating business, has been chartered in Chicago, by Messrs. M. Goldsmith, H. G. Coffee and J. L. Kerr. It is capitalized in \$150,000.

ACCORDING to the Flint (Mich.) *Journal*, Bay City (Mich.) has been doing its own electric lighting at an annual cost of \$90 per year per arc, but now that a private corporation has offered to perform the work at \$60 per lamp the city proposes to retire from the field.

THE total revenue collected during the year for the inspection of gas meters in Canada was \$7,922, as compared with \$6,946 collected in the previous year. The total expenses of the department of inspection were \$18,538 as against \$20,894 for the previous year; 104 tests of Toronto gas were made, and on no occasion did it appear to be below the standard. Belleville gas was once below the standard, Cornwall 5 times, and Ottawa 19 times.

AT a meeting of the Rhode Island Senate Committee on Corporations (held Friday, March 27), a public hearing was had on an act in amendment of an act entitled "An act to incorporate the Columbia Land Company," in which Chas. A. Henshaw, J. Edward Addicks, Samuel Little, Michael M. Cunniff, Spencer Borden and their associates petition to be incorporated under the name of the Wakefield Manufacturing Company for producing gas in the cities of Providence and Pawtucket. The Senate chamber was crowded in every part with prominent citizens from all parts of the State. Senator Wilbour took the chair and called upon those in favor of the act. Mr. S. A. Cook, Jr., said they started with the assumption that an act whose purpose it is to introduce a new industry into the State for fair and honorable competition will be looked upon favorably by the committee. The course of legislation in the past would warrant that assumption. They could not understand the reason of the opposition to capital coming into the city, increasing the taxation value and giving additional employment, especially at a time when there was an outcry against money going out of the State. The course of legislation of the State had been to grant any fair business enterprise the right to enter the field. If this act is refused, it will, perhaps, be the only instance where a competitor asking for incorporation has been so treated. He argued that the Company could only succeed by offering a better product at a greater price, or the same product at a lower price. The granting of a charter forces no one to take the product. He considered it was the duty of the remonstrants in the first place to show why the charter should not be granted. Senator Wilbour said it was the custom to hear the friends first. Mr. J. E. Addicks protested to being considered a foreigner. As a Baptist he felt he had some part and lot in the State of Roger Williams, and as a citizen of Delaware, he ought to have some regard from the other little State. He was a competitive gas man, and had been a merchant all his life. It was not until he reached the gas business that he found it disreputable to enter the gas business. He had been in it six or seven years. As a result of his appearance before the Legislature, in Newport last year the price had been reduced and water gas introduced. He desired to come right in with his associates and enter into fair competition. There was enough business in the city for two companies. His standing as a man was open for investigation, and newspaper talk did not affect him. He had tried to interest Providence gentlemen in the movement, but the power of the old corporation was so great that no one seemed to have courage. There was money enough behind the Company to carry on the business. City Solicitor Van Slyck said the city through its officers desires to control the municipality and not give up the rights of its streets to any corporation however respectable. Here was a bill unparalleled in the history of legislation in the State. It would permit the corporation to do anything it liked, and the injury to Westminster street would cost more than the \$25,000. It was a street so laid down that a strip could not be taken up and put back in the same condition, and this was to be done by a corporation over which the city was to have no control. The State never had enacted such legislation. He was not here to oppose the granting of the charter, but to ask that it be fixed as it always is, giving the Constitutional authorities control. If the committee permits this bill, it should stand upon the consent of the City Council. The old bill was subject to the Board of Aldermen, but the Common Council had grown sufficiently to warrant it in taking control of its highways. Mr. William A. Roelker appeared on behalf of the Providence Gas Company. The first that was heard of Mr. Addicks in Rhode Island was at the last May session in Newport, when he petitioned for an Act which is the same as the one presented to-day, with the exception that the most objectionable features were omitted. The Act which they asked for at Newport had a section providing that they should use the streets subject to the Board of Aldermen. That was now stricken out, and a bond substituted. Another difference was the power to purchase stock of other corporations. No such clause was to be found in any other Acts incorporating similar companies. It must have been put there for a purpose. He rehearsed the methods by which the bill had reached the present stage, and questioned the parliamentary correctness and fairness. It seemed to him that when a bill came with such extraordinary provisions and passed in such an extraordinary manner, there was something suspicious about it, and should have most careful consideration. The Company he represented had served the community well, at fair prices. There were nearly 1,000 shareholders in the Company, and all but 100 live in Rhode Island; and the stock was equally divided between men and women. They are our own people, and have a right to ask for fair treatment, and that you will not put a club into the hand of a corporation. Mr. Addicks was mistaken in supposing the price had been reduced on account of his appearances at Newport. The result of that gentleman's operations in Chicago was a gas trust. The average price in

Boston to day was \$1.67, here it was \$1.40; that is how he has benefited Boston. Referring to the Delaware letter, he said it was a case of a highwayman's "stand and deliver." It was plain on the face of it what Mr. Addicks wanted. He wanted a club put in his hand with which to strike the citizens down. Lieutenant-Governor Darling, of the Pawtucket Gas Company, said their stock was largely owned in that city and neighboring towns, and the passage of the Act would be great hardship to them. Mr. S. G. Stiness, Superintendent of the same Company, said competition had always resulted in a combination sooner or later, and the cost of it would eventually have to come from the pockets of the public. The Providence Gas Company has not increased its stock for many years, and the Pawtucket Gas Company had not increased its construction expenses until they gave the city electric light. The public was reaping the benefit from the small capital upon which dividends had to be paid. The policy which had been pursued in the past would be that of the future. They had reduced the price of gas from \$3.50 to \$1.53. Mr. L. M. Cook appeared as a citizen against the admittance of this corporation. The changing of the title of the Act would not have given any idea but what it was to be a little manufacturing company in Wakefield. If there was any agreement that there was need of a Constitutional amendment, it was such Act as this. Every measure brought before the House should be printed. If they could have had that rule in the House of Representatives, the Senate would not have been troubled with the matter. Mr. John F. Lonsdale protested against the bill appearing before the Senate with the indorsement of the House. The sense of that body was not taken upon it, it being run through with a lot of other charters.

A CONTROVERSY has arisen between the Jersey City Gas Company and the United Gas Improvement Company, relating to taxes on the former corporation. We have been informed that the latter Company in leasing the former agreed to assume all taxes on that corporation and pay them a clean dividend of 10 per cent. annually on the amount of stock of the Jersey City Company. The question in dispute is relative to the State taxes, which the United Gas Improvement Company refuse to pay, and for which no doubt a suit will be instituted.

THE Woburn (Mass.) Gas Light Company has declared a semi-annual dividend of 4 per cent.

SUIT has been begun in the Supreme Court by Margaret Sullivan against the California Electric Light Company, of San Francisco, to enjoin it from operating machinery on the premises on Jessie street, near Third. The plaintiff owns a house adjoining the works, and alleges that the machinery makes so much noise that it is impossible to carry on an ordinary conversation in her house; also that the jarring of the machinery has shaken her house so as to cause the plastering to fall from the walls and ceiling. She has therefore been unable to lease or rent the house, and rather than let it remain unoccupied has been compelled to live in it with her family and suffer these annoyances in question. In addition to the injunction \$10,000 damages are asked for.

GREENFIELD, MASS., March 29, 1890.—The voters will have another field day Monday afternoon, when they will close up the business of the annual town meeting. Were it not for the proposed wrestling match between the stockholders of the Electric Light and Gas Companies to see which Company can secure the contract to light the streets for five years, the session would be a tame affair. Some committees are to report, including one on the subject of buying a new almshouse nearer to where the poor people live, but this scheme, like others that are not quite ripened, will be quickly shelved on a motion to carry it over until the next annual meeting. Not so with the illuminating question. An attempt was made last week to have the selectmen assume the responsibility, but when the subject was opened up and the town fathers saw some of its bearings, they with one accord begged to be excused, preferring that their wise constituents should father the job. As a result a dozen of the lawyers and business men have been bottling up their oratory for Monday's contest. The gas people will urge that inasmuch as they pay about \$450 in taxes against less than half that amount as paid by the electric light concern, it is no more than fair that they should be given a wee bit of the public patronage. There are a great many who will strenuously oppose the making of a contract with any company for 5 years, on the ground that many changes are likely to be made during that time which will cheapen the lights, and of which the town should have the advantage. Of course, the farmers will generally come in to oppose the appropriation of any very liberal sum for any kind of light. —*Springfield Republican*.



A. M. CALLENDER & CO.,

PROPRIETORS.

EDITOR—Jos. R. Thomas, C.E.

ASST. EDITOR—T. J. Cunningham.

MANAGER—C. E. Sanderson.

PUBLISHED ON EACH MONDAY OF THE YEAR AT
No. 42 Pine Street, New York.

This is a recognized official organ of
LIGHT, HEAT, STEAM, WATER SUPPLY,
VENTILATION, SANITARY IMPROVEMENT,
AND GENERAL SCIENCE

TERMS:

Subscription—Three Dollars per annum, in advance. Single copies, 10 cents.

AGENTS.

NEW YORK.—AMERICAN NEWS CO., 39 and 41 Chambers Street.
PHILADELPHIA—PRATT & CO., Corner Ninth and Arch Streets.
Germany.—B. WESTERMANN & CO., of New York.

MONDAY, APRIL 7, 1890.

Gas Stocks.

Quotations by Geo. W. Close, Broker and Dealer in Gas Stocks,

16 WALL ST., NEW YORK CITY.

APRIL 7.

All communications will receive particular attention.
The following quotations are based on the par value of \$100 per share.

	Capital.	Par.	Bid	Asked
Consolidated.....	\$35,430,000	100	96 $\frac{3}{4}$	97
Central.....	500,000	50	—	—
“ Scrip.....	220,000	—	—	—
Equitable.....	4,000,000	100	117	119
“ Bonds.....	1,000,000	—	113	115
Harlem, Bonds.....	170,000	—	—	—
Metropolitan, Bonds....	658,000	—	115	120
Mutual.....	3,500,000	100	109	112
“ Bonds.....	1,500,000	—	100	102
Municipal, Bonds.....	750,000	—	—	—
Northern.....	—	50	—	—
“ Bonds.....	150,000	—	—	100
Standard Gas Co—				
Common Stock.....	5,000,000	100	—	45
Preferred.....	5,000,000	100	84	87
Yonkers.....	—	50	112	—
Richmond Co., S. I....	346,000	50	—	—
“ Bonds.....	20,000	—	—	—
Gas Co's of Brooklyn.				
Brooklyn.....	2,000,000	25	109	112
Citizens.....	1,200,000	20	—	63
“ S. F. Bonds... ..	320,000	1000	100	103
Fulton Municipal.....	3,000,000	100	124	126
“ Bonds.....	300,000	—	101	105
Peoples.....	1,000,000	10	80	82
“ Bonds (5's).....	368,000	—	100	—
“ “ (6's).....	94,000	—	100	—
Metropolitan.....	1,000,000	100	96	—
Nassau.....	1,000,000	25	120	—
“ C'tfs.....	700,000	1000	100	102
Williamsburgh.....	1,000,000	50	123	125
“ Bonds... ..	1,000,000	—	108	112
Out of Town Gas Companies.				
Boston United Gas Co.—				
1st Series S.F. Trust	7,000,000	1000	93	93 $\frac{1}{2}$
2d “ “ “	3,000,000	1000	71	72

Bay State Gas Co.—				
Stock.....	5,000,000	50	23 $\frac{1}{2}$	25
Income Bonds.....	2,000,000	1000	—	—
Buffalo Mutual, N. Y... ..	750,000	100	90	95
“ Bonds... ..	200,000	1000	95	100
Citizens, Newark.....	1,000,000	50	155	160
“ “ Bonds.....	45,000	—	—	—
Chicago Gas Trust.....	25,000,000	100	45 $\frac{3}{8}$ x	45 $\frac{1}{2}$
Chicago Gas Light. & Coke Co.—				
G't'd Gold Bonds	7,650,000	1000	93	93 $\frac{1}{4}$
Equitable Gas & Fuel Co., Chicago, Bonds	2,000,000	1000	—	102
People's Gas and Coke Co., Chicago—				
1st Mortgage.....	2,100,000	1000	—	100
2d “	2,500,000	1000	96	100
Consumers Gas Light Co., Jersey City.....	2,000,000	100	15	25
Bonds.....	600,000	1600	80	—
Cincinnati G. & C. Co..	6,000,000	100	201	203
Consumers Toronto....	1,000,000	50	190	200
Central, S. F., Cal.....			80	90
Capital, Sacramento, Cal			58	—
Consolidated, Balt.....	11,000,000	100	48 $\frac{1}{4}$	48 $\frac{1}{2}$
“ Bonds.....	6,400,000		107	107 $\frac{1}{2}$
Citizens Gas Lt. Co., Rochester, N. Y.....	500,000	—	75	90
Bonds.....	250,000	—	—	—
Hartford, Conn.....	750,000	25	102	108
Jersey City.....	750,000	20	186	190
Laclede Gas Light Co., St. Louis, Mo.—				
Common Stock....	7,500,000	100	14	17
Preferred “	2,500,000	100	—	—
Bonds.....	9,034,400	1000	82 $\frac{1}{2}$	83
Louisville, Ky.....	2,570,000	50	125	130
Little Falls, N. Y.....	50,000	100	—	100
“ Bonds	25,000	—	100	103
Montreal, Canada.....	2,000,000	100	200	208
Memphis (Tenn.) Gas... ..	750,000	100	48	51
“ Bonds.....	240,000	100	103	—
New Haven, Conn.....		25	200	—
Oakland, Cal.....			35	35 $\frac{1}{2}$
Peoples, Jersey City... ..			50	61
“ “ Bonds..			—	—
Paterson, N. J.....		25	99	102
Rochester, N. Y.....			50	99
Syracuse, N. Y.....	500,000	25	—	—
San Francisco Gas Co. San Francisco, Cal....	10,000,000	100	55 $\frac{1}{2}$	55 $\frac{3}{4}$
Washington, D. C.....	2,000,000	20	200	208
Wilmington, Del.. ..		50	88	90

Advertisers Index.

GAS ENGINEERS.	Page
Jos. R. Thomas, New York City	504
Wm. Henry White, New York City.....	507
Wm. Mooney, New York City.....	504
William Gardner, Pittsburgh, Pa.....	504
Fred. Bredel, N. Y. City.....	503
GAS WORKS APPARATUS AND CONSTRUCTION.	
James R. Floyd & Sons, New York City	507
Continental Iron Works, Greenpoint, L. I	507
Deily & Fowler, Phila., Pa.....	507
Kerr Murray Mfg. Co., Fort Wayne, Ind....	495
Stacey Mfg. Co., Cincinnati, Ohio.....	507
Bartlett, Hayward & Co., Baltimore, Md.....	505
Morris, Tasker & Co., Limited, Phila., Pa.....	505
Davis & Farnum Mfg. Co., Waltham, Mass.....	442
R. D. Wood & Co., Phila., Pa.....	506
Boston Foundry Co., Chicago, Ills	507
Smith & Sayre Manufacturing Co., New York City.....	506
Fred. Bredel, N. Y. City.....	503
United Gas Improvement Co., Phila., Pa.....	497
National Gas Light and Fuel Co., Chicago, Ills.....	494
Siupkin & Hillyer, Richmond, Va.	491
GAS AND WATER PIPES.	
Gloucester Iron Works, Phila., Pa.....	504
Mellert Foundry and Machine Co., Reading, Pa. (John Fox, Selling Agent, N. Y.).....	504
Ohio Pipe Co., Columbus, Ohio.....	504
M. J. Drummond, New York City.....	504
R. D. Wood & Co., Phila., Pa.....	506
Warren Foundry & Machine Co., New York City.....	504
Donaldson Iron Co., Emaus, Pa.....	504
Denuis Loug & Company, Louisville, Ky.....	504

PROCESSES.	
National Gas Light and Fuel Co., Chicago, Ills.....	494
Bartlett, Hayward & Co., Baltimore, Md.....	505
Wm. Henry White, N. Y. City.....	507
United Gas Improvement Co., Phila., Pa.....	497
The Fuel Gas and Light Improvement Co., N. Y. City.....	492
INCLINED RETORTS.	
Laclede Fire Brick Manuf'g Co., St. Louis, Mo.....	495
GASHOLDER TANKS.	
W. C. Whyte, New York City.. ..	94
J. P. Whittier, Brooklyn, N. Y.....	499
GASHOLDER PAINT.	
The Government Waterproof Paint Co., Boston, Mass.....	492
RETORTS AND FIREBRICK.	
J. H. Gautier & Co., Jersey City, N. J.	502
B. Kreisler & Sons, New York City.....	502
Adam Weber, New York City.....	502
Laclede Fire Brick Manuf'g Co., St. Louis, Mo	502
Brooklyn Retort and Fire Brick Works, Brooklyn, N. Y.....	502
Borgner & O'Brien, Phila., Pa.....	502
James Gardner, Jr., Pittsburgh, Pa.....	502
Henry Maurer & Son, New York City.....	503
Chicago Retort and Fire Brick Co., Chicago, Ills.....	502
Baltimore Retort and Fire Brick Co., Baltimore.....	502
Oakhill Gas Retort and Fire Brick Co., St. Louis, Mo.....	502
Boston Fire Brick Works, Boston, Mass.....	502
SCRUBBERS AND CONDENSERS.	
G. Shepard Page, New York City.....	496
R. D. Wood & Co., Phila., Pa.....	506
REGENERATIVE FURNACES.	
Bartlett, Hayward & Co., Baltimore, Md.....	505
Fred. Bredel, New York City.....	503
Chicago Retort and Firebrick Co., Chicago, Ills.....	502
Wm. Henry White, N. Y. City.....	507
J. H. Gautier & Co., Jersey City, N. J.....	503
GAS GOVERNORS.	
Connelly & Co., New York City.....	499
Fred. Bredel, N. Y. City.....	503
Friedrich Lux, London, England.. ..	491
SELF-SEALING MOUTHPIECE DOORS.	
Smith & Sayre Mfg. Co., New York City.....	506
TAR AND CARBONIC ACID EXTRACTOR.	
Geo. Shepard Page, N. Y. City.....	444
CEMENTS.	
C. L. Gerould & Co., Brooklyn, N. Y.....	502
GAS ENRICHERS.	
Standard Oil Co., Cleveland, Ohio.....	508
GAS METERS.	
John J. Griffin & Co., Phila., Pa.....	510
American Meter Co., New York and Philadelphia.....	511
The Goodwin Gas Stove and Meter Co., Philadelphia, Pa....	511
Helme & McIlhenny, Phila., Pa.....	511
D. McDonald & Co., Albany, N. Y.....	511
Nathaniel Tifts, Boston, Mass.....	510
Maryland Meter and Manufacturing Co., Baltimore, Md	440
Bell & Jones, Philadelphia, Pa.....	510
Harris Bros. & Co., Philadelphia, Pa.....	510
EXHAUSTERS.	
The P. H. & F. M. Roots Co., Connersville, Ind.....	498
Smith & Sayre Manufacturing Co., New York City.....	506
Wilbraham Bros., Philadelphia, Pa.....	499
Connelly & Co., New York City.....	499
GAS COALS.	
Penn Gas Coal Co., Phila., Pa.....	509
Perkins & Co., New York City.....	508
Newburgh Orrel Coal Co., Baltimore Md.....	509
Despard Coal Co., Baltimore, Md.....	509
Chesapeake and Ohio R. R. Coal Agency, N. Y. City.....	509
Westmoreland Coal Company, Phila., Pa	509
J. & W. Wood, New York City.....	508
CANNEL COALS.	
Perkins & Co., New York City.....	508
J. & W. Wood, New York City.....	508
VALVES.	
Ludlow Valve Manufacturing Co., Troy, N. Y.....	500
John McLean, New York City.....	500
Chapman Valve Manufacturing Co., Boston, Mass.....	500
R. D. Wood & Co., Phila., Pa.....	506
The P. H. & F. M. Roots Co., Connersville, Ind.....	498
GAS ENGINES.	
Schleicher, Schumm & Co., Phila., Pa.....	512
Clerk Gas Engine Co., Phila., Pa.....	500
Van Duzen Gas Engine Co., Cincinnati, Ohio.....	500
ENGINES AND BOILERS.	
Jarvis Engineering Co., Boston, Mass.....	499
Ball Engine Co., Erie, Pa.....	492
Westinghouse Machine Co., Pittsburgh, Pa.....	503
STEAM PUMPS.	
Van Duzen & Tift, Cincinnati, Ohio.....	491

GAS LAMPS.

G. Shepard Page, New York City..... 448
 Welsbach Incandescent Gas Light Co., Phila., Pa..... 493
 The Siemens-Lungren Company, Philadelphia, Pa..... 493
 Fiske, Coleman & Company, Boston, Mass..... 502

PURIFIER SCREENS.

John Cabot, New York City..... 500
 Bartlett, Hayward & Co., Baltimore, Md..... 500

GAS STOVES.

American Meter Co., New York and Philadelphia..... 501
 The Goodwin Gas Stove and Meter Co., Phila. Pa..... 460
 George M. Clark & Company, Chicago, Ills..... 493
 D. McDonald & Co., Albany, N. Y..... 511
 Maryland Meter and Manufacturing Co., Baltimore, Md..... 440
 Bell & Jones, Philadelphia, Pa..... 510
 Chicago Gas Stove Company, Chicago, Ills..... 492

STREET LAMPS.

J. G. Miner, Morrisania, New York City..... 491
 Bartlett Street Lamp Man'g Co., New York City..... 491

BURNERS.

C. A. Gefroerer, Phila., Pa..... 508
 H. W. Rappleye, Philadelphia, Pa..... 368

STEAM BLOWER FOR BURNING BREASE.

H. E. Parson, New York City..... 500

PURIFYING MATERIAL.

Connelly & Co., New York City..... 499
 Friedrich Lux, London, England..... 491
 Edgewater Lime Works, Edgewater, N. J..... 491

COKE CRUSHER.

C. M. Keller, Columbus, Ind..... 509

ELECTRICAL APPARATUS.

Wm. Henry White, N. Y. City..... 507

BOOKS, ETC.

Gerould's System Gas Bookkeeping..... 492
 1889. Directory. 1889..... 499
 King's Treatise..... 504
 Scientific Books..... 350
 Management of Small Gas Works..... 500
 Gas vs. Electricity..... 492
 Practical Electric Lighting..... 499
 Electric Light Primer..... 499
 American Gas Engineer and Superintendents' Handbook... 509
 Digest of Gas Law..... 492
 Fuel and its Applications..... 491
 Newhigging's Handbook..... 503

POSITION WANTED.

A Mechanical Engineer,

Experienced in Gas Manufacture, wishes a position as Superintendent of a Gas Works. Best of references given and asked. Salary, \$1,200.

"MECHANICAL ENGINEER," care this Journal, 765-1f or Box 972, West Bay City, Mich.

For Sale, Cheap.

Thirty Benches of 5's, with Cast Iron Hydraulic Main, 5-inch Stand and Dtp Pipes, Plugs, etc. Also, Stays and Rods for Forty Benches, with Door Frames and Doors, Mouthpieces, Lids, Cotter Bars, etc. Four Iron 4-Wheel Side-Drop Retort House Coke Wagons. Four Good Coal Carts. Twelve Charging Scoops. Hoes, Rakes, and Firing Tools. One Set Round Purifiers, 10 ft. diameter, 12-in. Seal, with Wet Center Seal. Washers, Scrubbers, and One Mackenzie Exhauster, 12-in. openings, 500,000 cu. ft. capacity. Will sell whole or in part, to suit purchaser. Address 772-4 MUNICIPAL GAS CO., Albany, N. Y.

FOR SALE,

The Ironwork for Twelve Benches of 6's, viz.: Cast Iron Hydraulic Main. 7-inch Dip-Pipes, Stand-Pipes, and Bridge-Pipes, complete. Floyd Mouthpieces and Self-Sealing Lids, 15x26 in Lids and Mouthpieces only in use over a year. Will be sold cheap. ISAAC C. BAXTER, 772-1f Detroit (Mich.) Gas Lt. Co.

FOR SALE.

A Complete Water Gas Plant. 60,000 Cu. Ft. Daily Capacity.

Fully equipped; all the latest improvements; includes Generator, Purifiers, and Holder. Can be removed to any part of the country, and set up at small cost. For further information apply to BRADFORD GAS LT. & HEATING CO., DUNKIRK, N. Y.

Fuel and Its Applications.

By E. J. MILLS, D.Sc. F.R.S., and F. J. ROWAN, C.E., assisted by others, including Mr. F. P. Dewey, of the Smithsonian Inst., Wash., D. C.

7 PLATES, AND 607 OTHER ILLUSTRATIONS. ROYAL OCTAVO. PAGES XX. 802. HANDSOME CLOTH, \$7.50. A. M. CALLENDER & CO., 42 Pine St., N. Y.

Simpkin & Hillyer
 RICHMOND, VA.

MANUFACTURERS OF

Gas Works Apparatus

BENCH CASTINGS, CONDENSERS, Scrubbers, Purifiers, Dry Center Seals, FOUR-WAY VALVES, GAS VALVES, SULPHATE OF AMMONIA APPARATUS, TANKS, ENGINES, BOILERS, PUMPS, ETC., ETC.

Plans, Specifications and Estimates furnished for new works, or alteration of old works. Correspondence solicited. Works, Newport News, Va.

Bartlett Street Lamp Mfg. Co.

MANUFACTURERS OF

Globe Lamps,

FOR

Streets, Parks, Public Buildings, Railroad Stations, etc.

LAMP POSTS

A Specialty.

Office and Salesroom,

40 & 42 COLLEGE PLACE, - - N. Y. CITY.

Gas Companies and others intending to erect Lamps and Posts will do well to communicate with us.

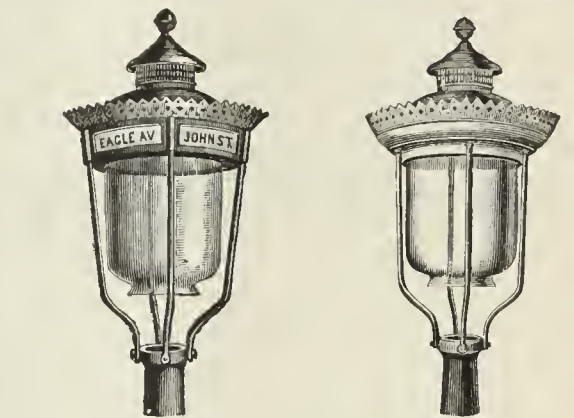

The Miner Street Lamps.

Jacob G. Miner,

No. 823 Eagle Ave., New York, N. Y.

VAN DUZEN'S

STEAMJET PUMP

For Water Supply Tanks. For Fire Pump on Yard or Switch Engines. For Round House General Work. For Draining Ponds, Pits, Cotter Dams, etc. 10 Sizes. \$7 to \$75. Thousands in use. Write for Descriptive Book to VAN DUZEN & TIFT, 106 E. Second St., CINCINNATI, O.

EDGEWATER LIME WORKS

Chas. F. McKenna, Proprietor.

SHELL LIME.

Lime by the Cargo for Gas Purification.

EDGEWATER, BERGEN CO., N. J.

Write for Testimonials and Prices.



THE NEW HANDY BINDER.

This article may be described as elegant in appearance, strong, durable, and possessing many special qualities of its own. It allows the opening of the pages perfectly flat, whether one or several numbers are in the binder. Any number can be taken out and replaced without disturbing the others. The papers are not mutilated for subsequent binding in permanent form. The binder is supplied with gilt side title, and is an ornament to any desk or reading table. The JOURNAL, filled in the Handy Binder, becomes a volume of great value, always convenient for instant reference. Handy Binder, Postage paid, \$1.00.

A. M. CALLENDER & CO., 42 Pine St., N. Y.

Position Wanted
 As Superintendent of Works.

Either Coal or Water Gas.

Address "B. W.,"

774-4

Care this Journal.

FOR SALE,

The Ironwork for 11 Benches of 5's, viz.:

Cast Iron Hydraulic Mains, 17 inch diameter, inside.

Dip Pipes, Bridge Pipes, Stand Pipes.

Mouthpieces and Lids.

Four Purifiers, 10 by 16 ft., with 10-inch Connections and dry Center Seal.

Four Purifiers, 5½ by 10 ft., with 6-inch Connections and Wet Center Seal.

Valves, 6-inch, 8-inch, and 10-inch.

DAVID MOORE, Treas. Salem Gas Lt. Co.,

770-1f

Salem, Mass.

GAS WORKS FOR SALE.

A CONTROLLING INTEREST IN SEVERAL

Interior California Coal Gas Plants,

now paying handsomely, are offered on very reasonable terms. This is an exceptionally good opportunity for practical gas men of limited means, wishing to remove to a mild and healthful climate, to acquire an established and paying business. Particulars given and full investigation solicited.

SECRETARY, 123 Beale Street,

760-3 mos.

San Francisco, Cal.

F. D. HARMON, PRES.

CHAS. C. ALLEN, SEC. AND TREAS.

P. W. MACKENZIE, CHIEF ENGR. & SUPT.

THE FUEL GAS AND LIGHT IMPROVEMENT CO.

OF AMERICA.

Owner of the Mackenzie Patents of Dec. 31, 1889,
For the United States, England, Russia, France, Germany, Austria, and Canada,
No. 32 Park Place, New York City.

This SYSTEM is an ABSOLUTELY NEW DEPARTURE IN THE MANUFACTURE OF FUEL AND ILLUMINATING GAS. The COST OF GAS IN THE HOLDER by our System is at least THIRTY PER CENT. LESS than that made by any other process of the day. The Gas contains neither SULPHUR nor other impurities, nor is there any resultant LAMPBLACK OR TAR RESIDUUM. The Gas is manufactured WHOLLY from LIQUID HYDROCARBONS, such as Lima, Penn. Crude, and Fuel Oils, Naphtha, etc. Neither PERISHABLE PIPES nor other RETORTS, NOR THEIR EQUIVALENTS, are used. The Gas requires NO PURIFICATION. Neither COAL, COKE, nor any other HARD CARBONS enter into the manufacture or composition of the Gas, thereby requiring LESS LABOR THAN ANY OTHER METHOD. The APPARATUS is extremely SIMPLE, SUBSTANTIAL, and DURABLE. Works under our system can be CONTINUOUS or ALTERNATING. If alternating, the Nitrogen present will be less than 4½ per cent. If continuous, the limited amount of Nitrogen present is neutralized by Carbon. One gallon of Lima oil by our process EQUALS ALL THE COAL required for making 1,000 feet of carbureted Water Gas.

GAS vs. ELECTRIC LIGHT.

We would invite attention to the able and exhaustive argument of General A. Hickenlooper, President of the Cincinnati Gas Light and Coke Company, contained in a handsome pamphlet of 96 pages, entitled

"EDISON'S INCANDESCENT ELECTRIC LIGHTS FOR STREET ILLUMINATION. REPORT OF AN ARGUMENT DELIVERED BY A. HICKENLOOPER BEFORE THE COMMITTEE ON LIGHT, MUNICIPAL COUNCIL, CITY OF CINCINNATI, JULY 22, 1886."

This is a subject of special interest to all Gas Light Companies.

Prices.

25 copies.....	\$7.50	100 copies.....	\$22.50
50 copies.....	12.50	250 copies.....	50.00

A sample copy will be sent by mail on receipt of 50 cts
A. M. CALLENDER, A. CO., 42 PINE ST., N. Y. CITY

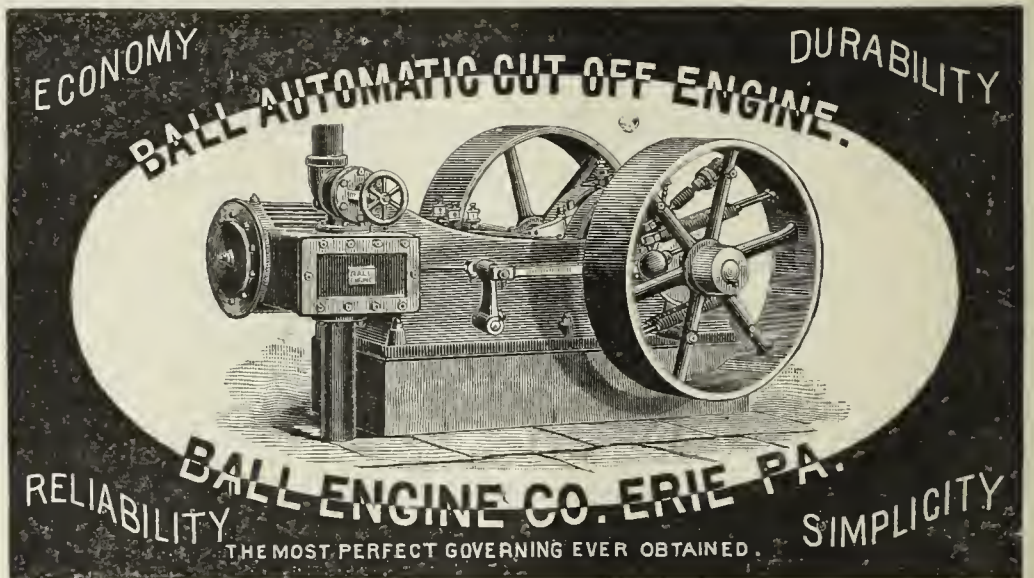

GREENOUGH'S "DIGEST OF GAS LAW."

Price, \$5.00.

This is a valuable and important work, a copy of which should be in the possession of every gas company in the country, whether large or small. As a book of reference it will be found invaluable. It is the only work of the kind which has ever been published in this country, and is most complete. Handsomely bound. Orders may be sent to

A. M. CALLENDER & CO.,
42 Pine Street, N. Y.

PATENTS.

FRANKLIN H. HOUGH
Solicitor of American & Foreign Patents.
925 F. ST., WASHINGTON, D. C.
(NEAR U. S. PATENT OFFICE.)

Personal attention given to the preparation and prosecution of applications for Letters Patent. All business before the U. S. Patent Office attended to for moderate fees. No Agency in the United States possesses superior facilities for obtaining Patents, or for ascertaining the patentability of inventions. Copies of patents furnished for 25 cents each. Correspondence solicited.

GASHOLDER PAINT.

Use Only
THE GOVERNMENT WATERPROOF PAINT.
Proof against Ammonia, and Absolutely Waterproof. Send for Prices and Particulars.
THE GOVERNMENT WATERPROOF PAINT CO., 122 Milk Street, Boston, Mass.

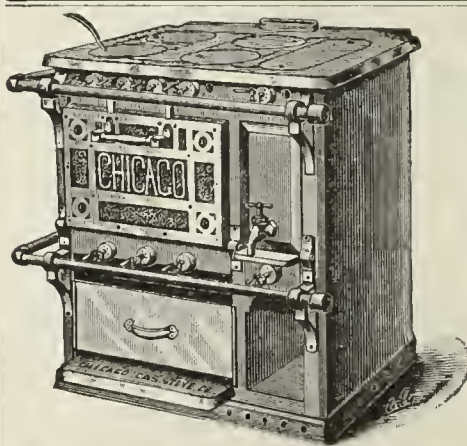

CHICAGO GAS STOVE CO.

MANUFACTURERS OF ALL KINDS OF

Gas Cooking and Heating
APPLIANCES.

117-119 Lake St., CHICAGO.
Send for Catalogue.

FRIEDRICH LUX,

Ludwigshafen am Rhein and London.

Lux Mass
GAS GOVERNORS,
Gas Balance.

GEROULD'S

System Gas Bookkeeping.

Approved and adopted by many of the prominent Gas Engineers of the Country.

Sample Sheets and Price-List furnished free on application to

L. P. GEROULD, - - Mendota, Ill.

The Gordon Portico Lamp.

A successful Competitor of the Arc Electric Light for lighting Store Fronts, Show Windows, Depots, Railway Sheds, etc., etc.

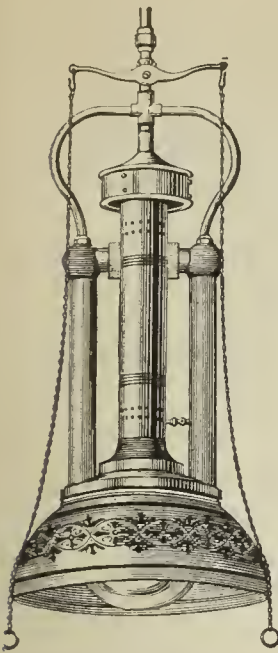

Gordon Portico Lamp.

The Gordon Street Lamp.

A Successful Competitor of the Arc Electric Light for lighting Streets, etc., etc.

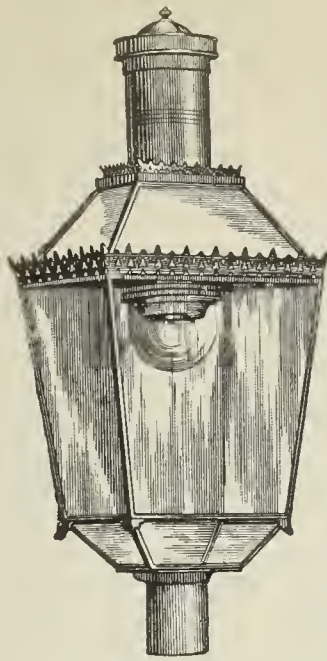

Gordon Street Lamp.

The Lungren Lamp.

A Successful Competitor of the Incandescent Electric Light for Interiors, etc. Is especially applicable for the lighting of Offices, Stores, Factories, Mills, Show Windows, Libraries, and all situations where an increased illumination is desired.

More than 25,000 Lungren Lamps are now in use. Testimonials, references, or any desired information will be cheerfully given.

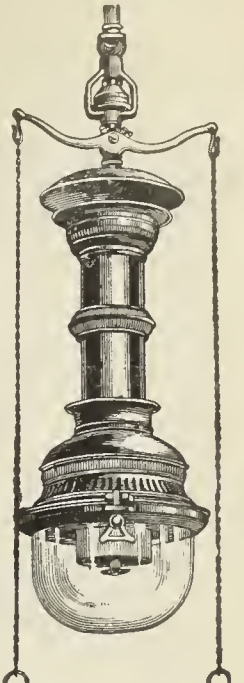

Lungren Lamp.

THE SIEMENS-LUNGREN CO., N.E. Cor. 21st St. & Washington Av., PHILADELPHIA.

WELSBACH SYSTEM OF Incandescent Gas Lighting.

OFFICE, DREXEL BUILDING, PHILA., PA.

At the Fall Session of the Board of Supervisors of Winnebago County, held at the County Court House, Oshkosh, Wis., Nov. 26, 1889, the report submitted by Mr. C. W. Cook, Chairman of the Committee on Public Buildings, recommending the use of the Welsbach Incandescent Gas Burner in the Buildings under their charge, was unanimously adopted, because of the extreme economy in the consumption of Gas and the superior character of the light obtained.

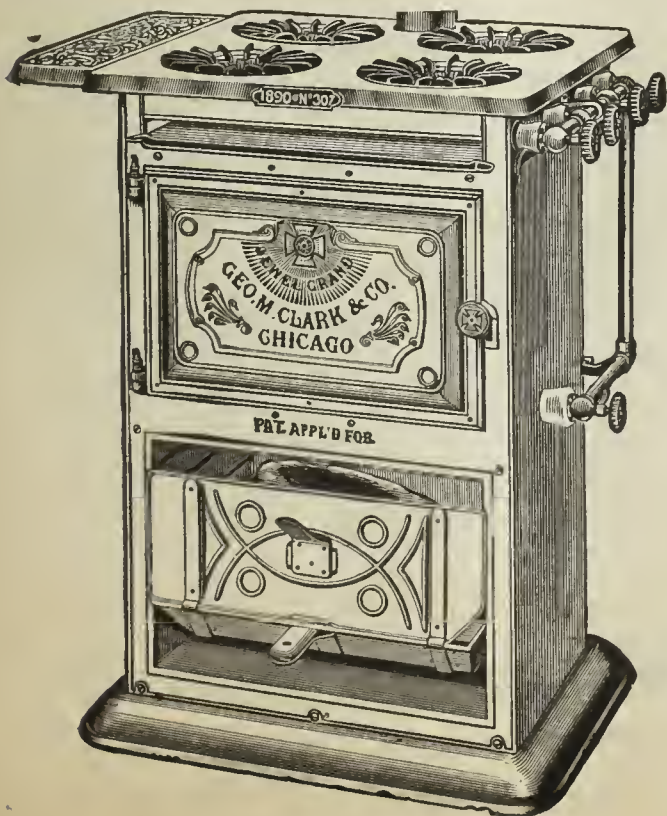

JEWEL GAS STOVES

MANUFACTURED BY

GEORGE M. CLARK & COMPANY,

Nos. 157 & 159 Superior Street, - - - Chicago, Ill.

EVERY CONCEIVABLE SIZE AND STYLE,

Ranging in Prices from \$1.50 to \$30.00.

WE USE NO GAS COCKS.

All Flames are Regulated by a Direct Needle Valve.

The JEWEL

IS THE

Only Well-Made Gas Stove on the Market.



Write for our 1890 Catalogue and see for yourself.

NATIONAL GAS LIGHT AND FUEL CO.,

218 La Salle Street, Chicago.

C. D. HAUK, Prest. & Gen'l Manager.

A. W. GREEN, Vice-Prest.

N. A. McCLARY, Sec. & Treas.

E. E. MORRELL, Engr.

GAS WORKS

Built, Remodeled, Leased, and Purchased.

71 Springer Cupolas
have been installed
in the U. S. during
the past four years.

The total capacity of
Springer Apparatus
now in use is over
25,000,000 ft. daily.

THE SPRINGER CUPOLA SYSTEM

Has Proven Itself the most Economical and Satisfactory Method of Gas Manufacture ever brought to the attention of the Gas Fraternity.

GUARANTEED ESTIMATES of Cost of Gas Furnished on Application.

GASHOLDER TANK CONSTRUCTION, ETC.

Gas Companies and others about to erect Gasholders will find it profitable to consult W. C. Whyte, who for over 30 years has made a specialty of

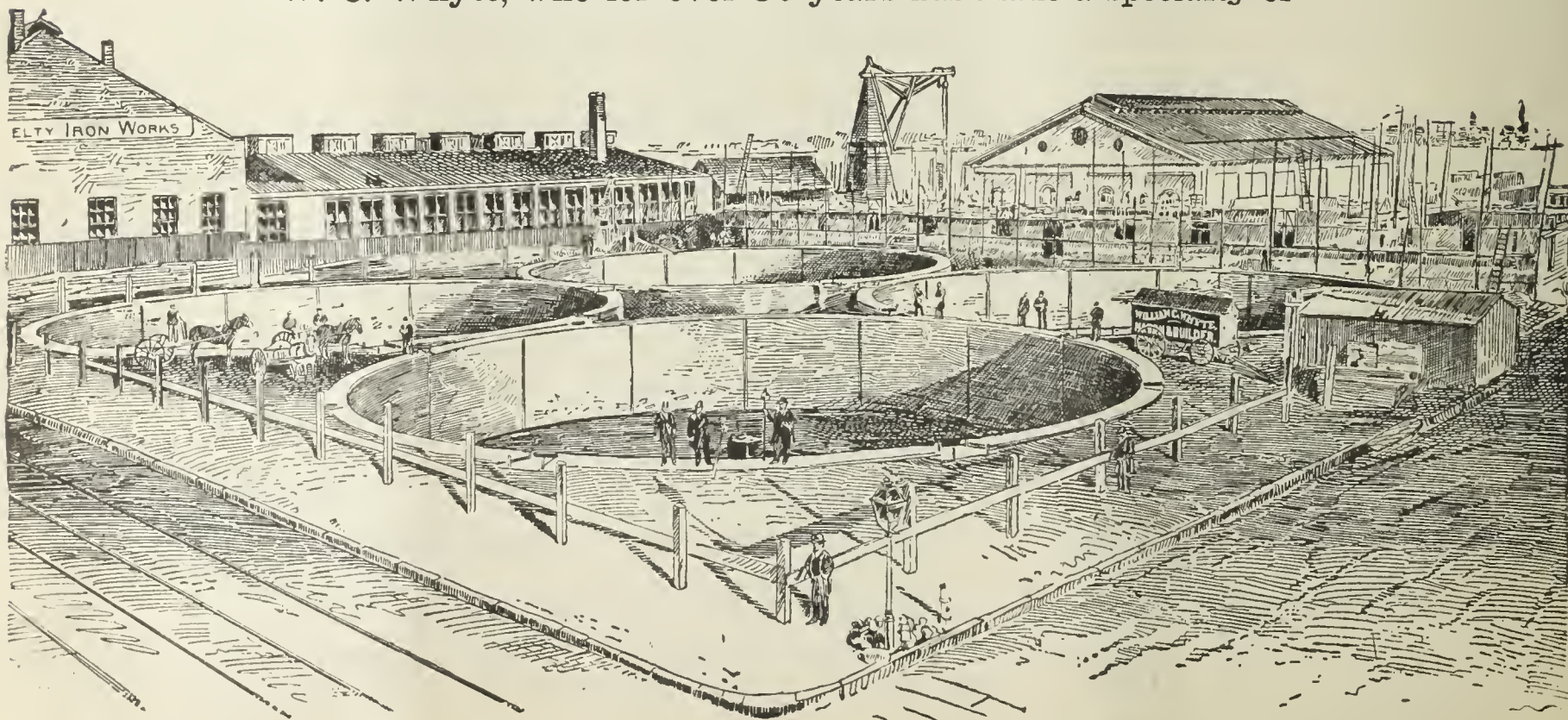

Tank Excavation and Mason Work.

Fifty Tanks now in operation show the sort of work done. Address

W. C. WHYTE, - No. 15 Cortlandt Street, N. Y. City.

THIS SPACE
 WILL BE
 Occupied Next Month by the
KERR MURRAY MFG. CO.
 FORT WAYNE, IND.
**GAS WORKS
 APPARATUS
 AND
 HOLDERS.**

LACLEDE FIRE BRICK MANUFACTURING COMPANY,

ST. LOUIS, MO.

Exclusive Agents in the United States

FOR THE

Coze System of Inclined Retorts.

IT IS THE COMING BENCH
FOR MAKING COAL GAS.

*It will Save from 50 to
60 per ct. in Labor.*

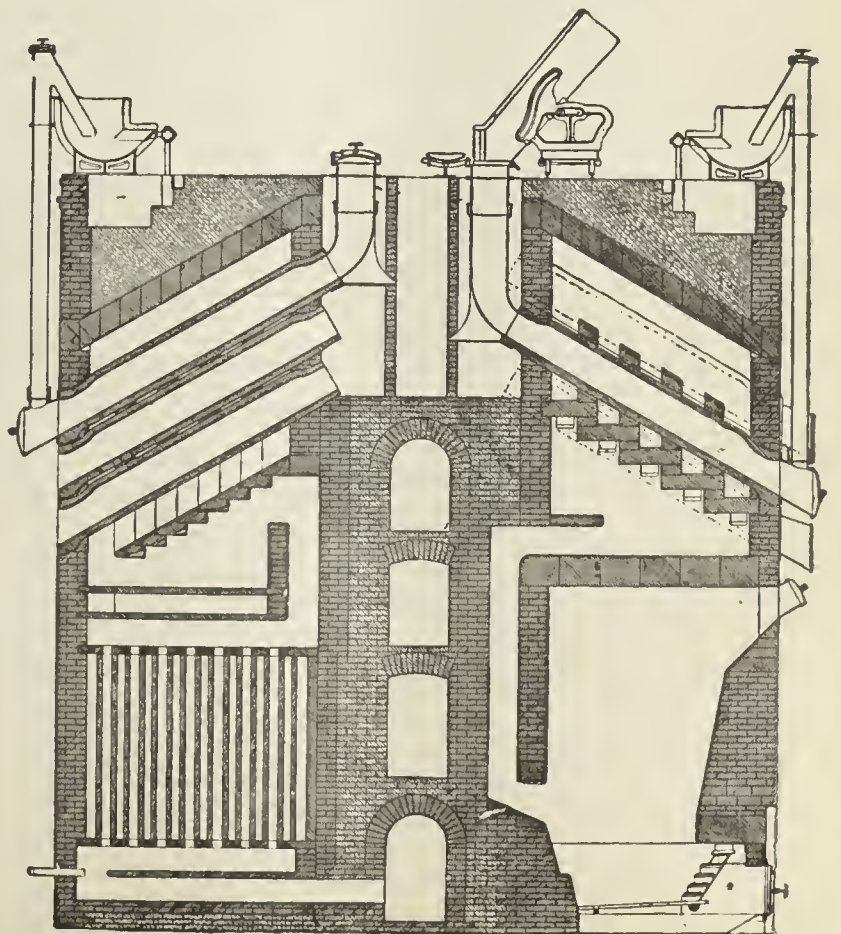
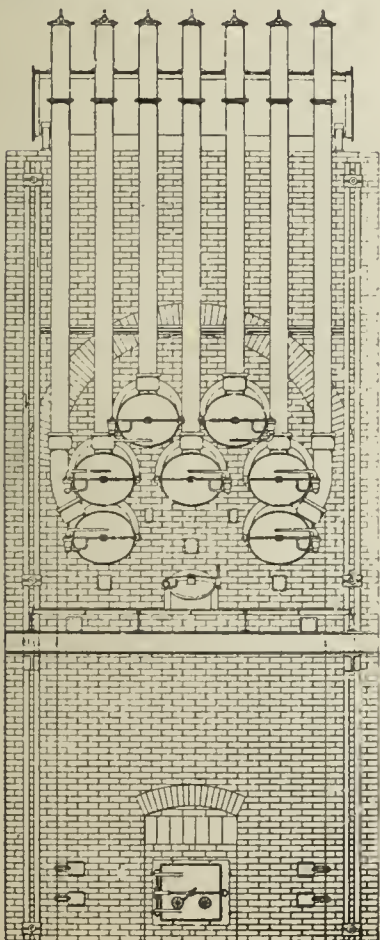

ESTIMATES AND PLANS FURNISHED BY THE

LACLEDE FIRE BRICK MFG. CO., ST. LOUIS, MO.

KIRKHAM, HULETT & CHANDLER, LIMITED.

PATENT "STANDARD" WASHER-SCRUBBERS
Erected and in course of construction at present date:

Capacity. Cubic feet per day.	Capacity. Cubic feet per day.	Capacity. Cubic feet per day.	Capacity. Cubic feet per day.
Altrincham..... 600,000	Dublin..... 3,000,000	LONDON—Continued.	Ober Schlesian..... 1,500,000
Adelaide..... 600,000	Dowlais..... 100,000	Shoreditch..... 2,500,000	Otto & Co.'s Coke Works..... 1,500,000
Aldershot..... 200,000	Donai..... 500,000	Pancras..... 1,500,000	Plymouth..... 2,000,000
Allegheny, U. S. A. 1,000,000	Denton..... 500,000	"..... 1,500,000	Parramatta, N. S. W..... 100,000
Ashton-under-Lyne..... 1,250,000	Derby, U.S.A. 350,000	Pimlico..... 2,000,000	Prescott..... 150,000
Amsterdam..... 1,500,000	Denver, " 500,000	Nine Elms..... 3,000,000	Providence, U.S.A. 750,000
"..... 1,500,000	"..... 1,000,000	"..... 3,000,000	"..... 750,000
Annaberg..... 200,000	Dusseldorf..... 750,000	South Metropolitan Co:—	Plauen..... 300,000
Arcachon..... 100,000	"..... 500,000	Greenwich..... 3,000,000	"..... 300,000
Animal Charcoal Co..... 200,000	Dumfries..... 500,000	Woolwich..... 400,000	Portsmouth..... 2,500,000
Altoona, U.S.A. 350,000	Dunedin, N.Z..... 400,000	Vauxhall..... 3,000,000	"..... 2,500,000
Buxton..... 250,000	Darlington..... 1,250,000	"..... 3,000,000	Pittsburgh, U.S.A. 1,500,000
Bradford..... 1,000,000	Detroit, U.S.A. 750,000	Lea Bridge..... 300,000	Portland, " 560,000
"..... 1,250,000	Edinburgh..... 1,500,000	West Ham..... 1,500,000	Pawtucket, " 500,000
"..... 1,250,000	"..... 2,000,000	Leeds..... 2,000,000	Quebec 250,000
"..... 1,250,000	Enfield..... 300,000	"..... 3,000,000	Radcliffe..... 750,000
"..... 1,000,000	Essen..... 300,000	"..... 3,000,000	Rouen..... 250,000
"..... 1,000,000	Elbing..... 150,000	"..... 3,000,000	Ramsgate..... 1,000,000
"..... 3,000,000	Falmouth..... 150,000	"..... 2,000,000	Reigate..... 200,000
Bremen..... 150,000	Frankfort..... 300,000	"..... 3,000,000	Richmond, U.S.A. 250,000
Baltimore, U.S.A. 1,000,000	Farnworth..... 400,000	"..... 3,000,000	Roxbury, " 500,000
"..... 1,000,000	Feuton..... 400,000	"..... 3,000,000	Runcorn Soap Co..... 20,000
"..... 1,000,000	Friedenshutte..... 500,000	"..... 2,000,000	Rockhampton, N. S. W..... 125,000
Salmain, N.S.W..... 125,000	Furth..... 400,000	Leominster..... 150,000	Richmond..... 1,500,000
Bishops Stortford..... 150,000	Freiburg..... 200,000	Leiden..... 560,000	Reading..... 2,000,000
Blackpool..... 400,000	Goole..... 250,000	"..... 600,000	Reichenbach..... 200,000
Brussels..... 1,250,000	Glossop..... 300,000	Liverpool..... 2,000,000	Salford..... 1,750,000
"..... 1,250,000	Guildford..... 300,000	"..... 2,000,000	"..... 1,750,000
"..... 750,000	Gloucester..... 1,250,000	"..... 2,000,000	"..... 1,750,000
"..... 1,250,000	Gera..... 300,000	"..... 2,000,000	Smethwick..... 750,000
Banbury..... 250,000	Grafton, N.S.W..... 100,000	"..... 2,000,000	Sydney, N. S. W..... 1,000,000
Birmingham..... 5,000,000	Grieg..... 300,000	"..... 3,000,000	"..... 1,000,000
Birkenhead..... 2,500,000	Georgetown, U.S.A. 250,000	Lincoln..... 1,000,000	"..... 2,500,000
Blackburn..... 1,500,000	Gluckauf..... 200,000	"..... 600,000	"..... 50,000
Bochum..... 600,000	Heywood..... 600,000	Lowell, U. S. A. 1,000,000	"..... 50,000
Burtonisland..... 250,000	Hollywood..... 125,000	Louisville 1,500,000	Sunderland..... 1,500,000
Boston, U.S.A. 2,000,000	Huy..... 70,000	Long Eaton..... 500,000	St. Josephs, U.S.A. 250,000
Brisbane..... 1,500,000	Harrow..... 250,000	Lilie..... 900,000	Spa..... 100,000
"..... 300,000	Harrogate..... 250,000	"..... 450,000	Sevenoaks..... 300,000
Burton-on-Trent..... 1,500,000	Halstead..... 150,000	"..... 750,000	St. Petersburg..... 2,000,000
Barcelona..... 350,000	Heilbronn..... 200,000	"..... 250,000	"..... 1,500,000
Barking..... 100,000	Havana, Cuba. 750,000	"..... 250,000	St. Louis, U.S.A. 2,000,000
Baerlien & Co..... 20,000	Hastings..... 1,500,000	Luckenwalde..... 330,000	"..... 2,000,000
"..... 20,000	Huddersfield..... 300,000	Liegwitz..... 300,000	"..... 1,000,000
Bombay..... 400,000	"..... 750,000	Lincoln, U. S. A. 250,000	Laclede 1,000,000
Buffalo, U.S.A., Mutnal. 750,000	"..... 1,500,000	Lawrence 500,000	Silesian Coal Co..... 600,000
"..... Citizen 500,000	Hof..... 200,000	Lynn 300,000	San Francisco, U.S.A. 2,000,000
Brookline, U.S.A. 500,000	Hampton Wick..... 500,000	Lyons..... 1,500,000	"..... 2,000,000
Bergen..... 350,000	Heckmondwicke..... 500,000	Maidstone..... 1,000,000	Sheepbridge Coal Co..... 40,000
Berlin..... 1,250,000	Heverford west..... 100,000	Marseilles..... 1,500,000	Stettin..... 200,000
Bournemouth..... 1,000,000	Halifax, N.S. 350,000	"..... 1,500,000	Singapore..... 300,000
Bridgeport, U.S.A. 500,000	Hamm..... 200,000	Mons..... 500,000	Sutton..... 500,000
Brunswick..... 300,000	Halle..... 400,000	Malines..... 250,000	Tonbridge..... 150,000
Beck & Co., St. Louis 100,000	Heidelberg..... 300,000	Melbourne..... 1,500,000	Tipton..... 400,000
Barmen Rittershausen..... 600,000	Hartford, U.S.A. 1,000,000	"..... 1,500,000	Tottenham..... 1,000,000
Bexhill..... 125,000	Ilkeston..... 300,000	"..... 1,500,000	Toledo, U.S.A. 750,000
Brooklyn, U.S.A. 1,000,000	Inverness..... 250,000	"..... 1,500,000	Toronto 1,000,000
"..... Nassau 1,000,000	Ilkley..... 200,000	"..... 1,500,000	Uxbridge..... 300,000
Brunner, Mond & Co..... 400,000	Ilford..... 100,000	Manchester..... 2,500,000	Valparaiso 500,000
Cheltenham..... 2,000,000	Kingston-on-Hull..... 400,000	Middleton..... 400,000	West Bromwich..... 1,000,000
Cannes..... 200,000	Kidderminster..... 750,000	Manley, N. S. W..... 100,000	Willenhall..... 250,000
Croydon..... 1,500,000	Kidsgrove..... 100,000	Minneapolis, U. S. A. 750,000	Weston-super-Mare..... 500,000
Copenhagen..... 200,000	Konigberg..... 1,000,000	Magdeburg..... 300,000	Waltham..... 150,000
Clevedon..... 200,000	King's Lynn..... 300,000	Memphis, U. S. A. 750,000	Wormwood Scrubs..... 300,000
Columbus, U.S.A. 500,000	LONDON:—	Nottingham..... 1,250,000	Williamsburg, U.S.A. 600,000
Cincinnati, " 1,500,000	The Gaslight and Coke Co.:	"..... 2,500,000	"..... 600,000
"..... 1,500,000	Beckton..... 1,250,000	"..... 2,500,000	Wellington..... 150,000
Chicago 3,000,000	"..... 1,250,000	"..... 2,000,000	Warwick..... 300,000
"..... 1,000,000	"..... 1,250,000	"..... 1,500,000	Wheeling, U.S.A. 500,000
"..... 1,000,000	"..... 1,250,000	"..... 2,000,000	Walker..... 300,000
Chemnitz..... 1,000,000	"..... 1,250,000	Newport, U.S.A. 430,000	Westgate..... 100,000
Crewe..... 1,250,000	"..... 1,250,000	Newmarket..... 150,000	Wilmington, U.S.A. 500,000
Colonial Gas Works Co..... 100,000	"..... 1,250,000	Newark, U.S.A. 680,000	Windsor, N. S. W..... 100,000
Cadiz..... 300,000	"..... 2,500,000	Northfleet..... 200,000	Wolverton..... 100,000
Charlottenburg..... 600,000	"..... 2,500,000	New York, U.S.A. 2,000,000	Wellington, N. Z..... 250,000
Dudley..... 750,000	Silvertown..... 1,000,000	Nice..... 600,000	Whitchurch..... 175,000
Driffield..... 100,000	Bromley..... 2,000,000	Newcastle, N. S. W..... 200,000	Washington, U.S.A. 2,000,000
Dukenfield..... 500,000	"..... 1,500,000	Numea, "..... 100,000	Wallasey..... 750,000
Dover..... 750,000	"..... 1,500,000	Newark..... 350,000	Weimar..... 150,000
"..... 1,000,000	"..... 1,500,000	Oldbury..... 500,000	Wurzen..... 200,000
Deal..... 200,000	"..... 2,000,000	Otley..... 200,000	Worcester, U.S.A. 750,000
Derby 1,500,000	"..... 1,500,000	Oswestry..... 250,000	Yeadon..... 500,000
			Yeovil..... 250,000

SOLE AGENT FOR WESTERN HEMISPHERE,
GEO. SHEPARD PAGE, 69 WALL STREET, NEW YORK.

THE UNITED GAS IMPROVEMENT CO.

Drexel Building,

CHESTNUT AND FIFTH STREETS,

PHILADELPHIA, PA.

OFFICERS:

WILLIAM W. GIBBS, President.

GEORGE PHILLER, Vice-President.

SAM'L T. BODINE, Gen'l Manager.

RANDAL MORGAN, Gen'l Counsel.

EDWARD C. LEE, Sec'y and Treas.

ALEX. C. HUMPHREYS, Gen'l Supt.

WALTON CLARK, Ass't Gen'l Supt.

H. H. EDGERTON, Chem. and Eng'r.

DIRECTORS:

GEORGE PHILLER,

THOMAS DOLAN,

HENRY C. GIBSON,

WM. T. CARTER,

WILLIAM G. WARDEN,

SAM'L T. BODINE.

BUILDERS, LESSEES AND PURCHASERS OF

➤ GAS WORKS. ➤

ROOTS' GAS AND BYE-PASS VALVES.

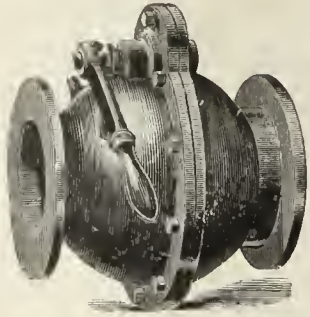

GAS VALVE

Quick Acting,
Simple,
Efficient, Durable.

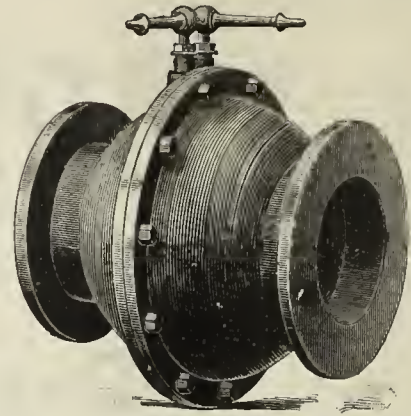

BYE-PASS VALVE.

Automatic Action,
Reliable
Simple, Durable.

Thousands now in use and giving perfect satisfaction. Write for Catalogue and Prices.

ROOTS' NEW GAS EXHAUSTER.

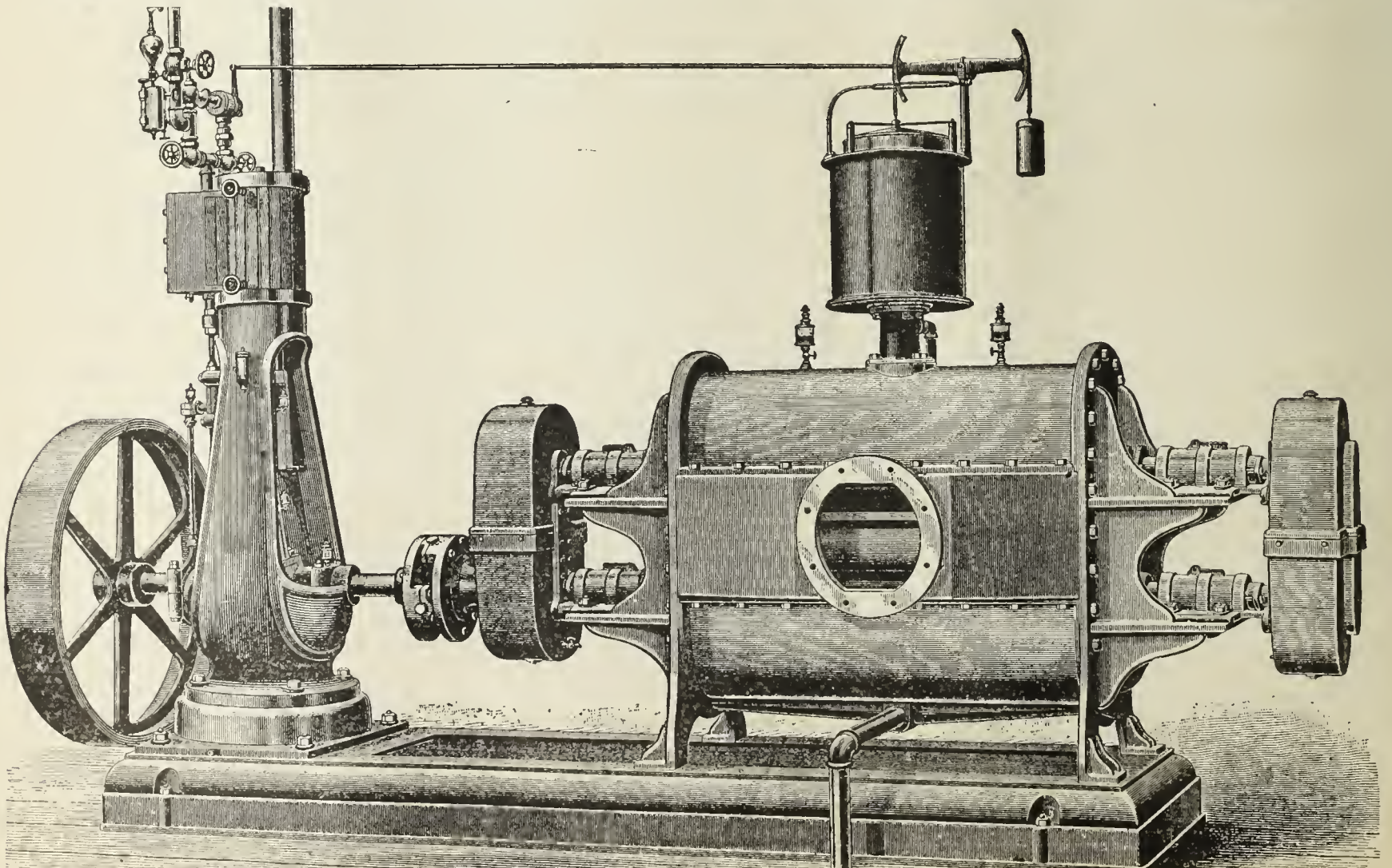

THE P. H. & F. M. ROOTS CO., - - CONNERSVILLE, IND.

S. S. TOWNSEND, Gen. Agt., 22 Cortlandt St., N. Y.

COOKE & CO., Selling Agts., 22 Cortlandt St., N. Y.

CONNELLY & CO.,

SOLE MANUFACTURERS OF THEIR PATENTED SPECIALTIES.

"IRON SPONGE." Saves money, saves labor, and is the most efficient purifying agent ever offered as a substitute for lime. Now used in every State in the Union, and purifying daily over thirty-five million cubic feet. Should be used in every gas works. Its own saving will pay for it many times over.

AUTOMATIC GOVERNOR. Has been on the market but three years, and in that time has been introduced more generally than any invention ever designed for use in gas works. Over two hundred of them now in use. Sensitive; reliable; perfectly automatic; reduces leakage; satisfies consumers, and gives great relief to the Manager. No gas works is complete without one of these machines.

STEAM JET EXHAUSTER. Designed particularly for small works. Combines Exhaust Tube, Steam Governor Gas Compensator, and Bye-Pass Valves in the most compact form possible; occupies but little space; uses very little steam; operated by ordinary workmen; saves formation of carbon in retorts; increases yield 10 to 15 per cent. Specially adapted for mixing air with oil gas. No works too small to use them profitably.

Prices given on all our specialties delivered at any point in the United States. Correspondence solicited.

CONNELLY & CO., No. 111 Broadway, New York City.

WILBRAHAM GAS EXHAUSTER

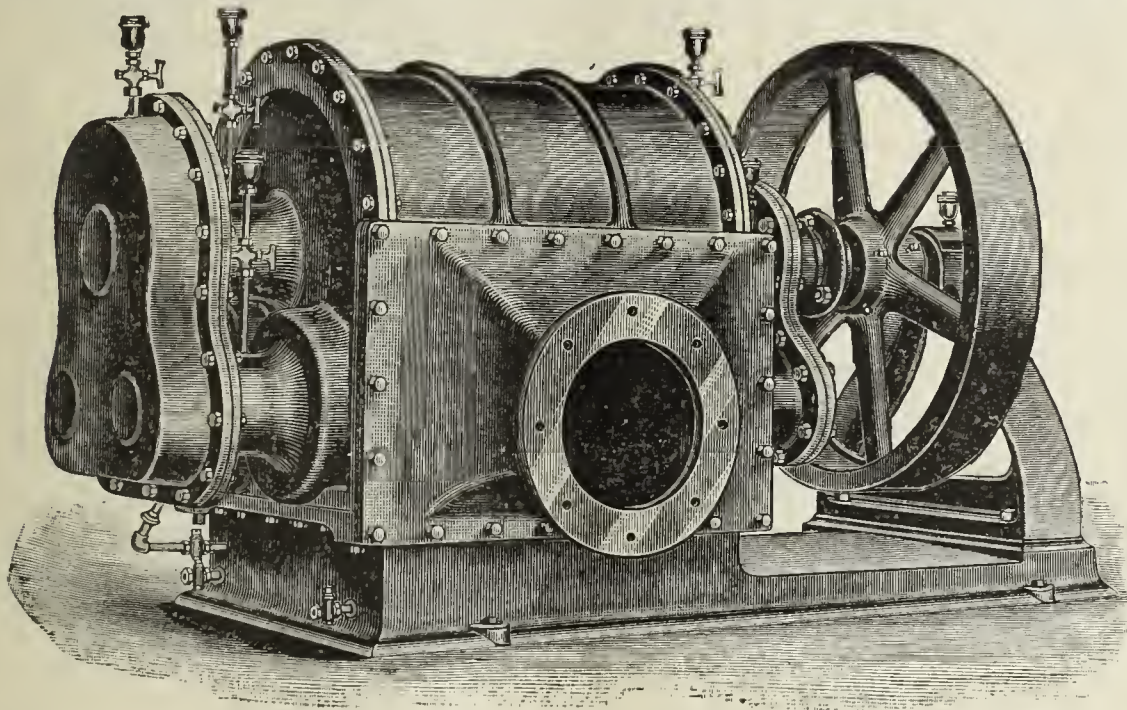

WILBRAHAM BROS.,
PHILADELPHIA, PA.

JARVIS ENGINEERING CO.,

61 Oliver St., Boston, Mass.

CONTRACTORS FOR ERECTING
COMPLETE STEAM OUTFITS FOR ELECTRIC
LIGHTING STATIONS.

Steel Boilers set with Jarvis Pat. Boiler Setting

To burn **COKE SCREENINGS** for Fuel.

ARMINGTON & SIMS CO. ENGINES,

Belting direct to Dynamos, without using Shafting.

SEND FOR CIRCULARS.

REFERENCES.—Charlestown Gas & Electric Light Co., Charles town, Mass.; Schenectady Gas & Electric Light Co., Schenectady N. Y.; Brookline Gas Co., Brookline, Mass.

Practical Electric Lighting

By A. BROMLEY HOLMES, A.M.I.C.E.

With 87 Illustrations. Third Edition. Price, \$1.00.

Electric Light Primer.

By CHARLES L. LEVEY.

A simple and comprehensive Digest of all the most important facts connected with the running of the Dynamo and Electric Lights, with Precautions for Safety, etc.

Price, 50 cents.

A. M. CALLENDER & CO., 42 Pine St., N. Y.

Gasholder Tanks & Gas Works Masonry Complete.

PLANS PREPARED AND ESTIMATES FURNISHED AT SHORT NOTICE.

J. P. WHITTIER, - - 499 Wythe Av., Brooklyn, N. Y.

1889 DIRECTORY 1889

OF THE GAS LIGHT COMPANIES of the UNITED STATES & CANADA.

Price, \$3.00.

A. M. CALLENDER & CO., No. 42 Pine Street, N. Y. City.



CHAPMAN VALVE MANUFACTURING CO.,

MANUFACTURERS OF

Valves and Gates for Gas, Ammonia, Water, Etc.

Also, Gate Fire Hydrants With and Without Independent Nozzle Valve. All Work Guaranteed.

WORKS & GEN'L OFFICE:
Indian Orchard, Mass.

TREASURER'S OFFICE:
72 Kilby & 112 Milk Sts, Boston, Mass.

LUDLOW VALVE MFG. CO.

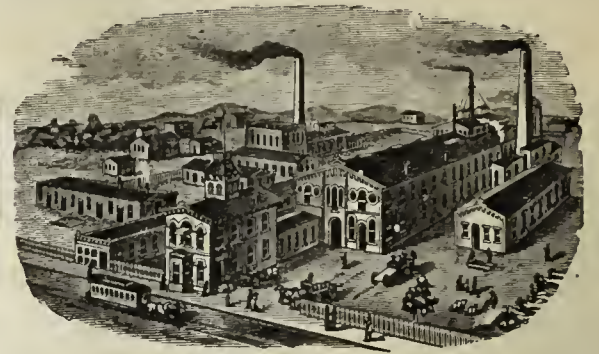

OFFICE AND WORKS,

938 to 954 River Street and 67 to 83 Vall Av.,
TROY, N. Y.

Parson's Steam Blower,

FOR IMPROVING BAD DRAUGHT IN BOILERS, AND FOR BURNING BREEZE OR OTHER WASTE MATERIAL.

PARSON'S TAR BURNER,

FOR UTILIZING COAL TAR AS FUEL.

PARSON'S AIR JET TUBE CLEANER,

FOR CLEANING BOILER TUBES.

These devices are all first-class. They will be sent to any responsible party for trial. No sale unless satisfactory. Manufactured by the WATERTOWN STEAM BLOWER COMPANY.

H. E. PARSON, Supt., 33 & 35 Liberty St., N.Y.

MILLS' REVERSIBLE LIME TRAY,

AND

WOODWORK

Of Every Description

NEEDED BY GAS WORKS.

SEND FOR CIRCULAR AND PRICE LIST TO

BARTLETT, HAYWARD & CO.,

Pratt and Scott Streets, Baltimore, Md.

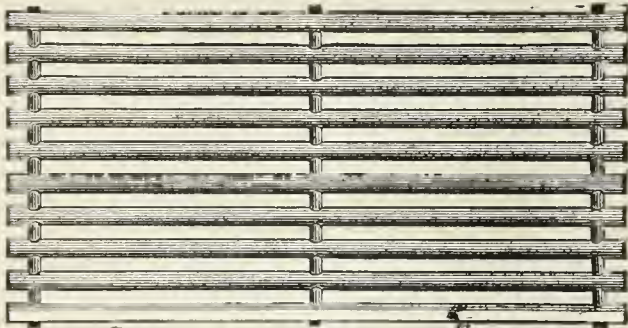

Hydraulic Main Dip Regulators, also
Check Valves, Foot Valves, Yard-
wash and Fire Hydrants.
Send for Circulars.



Valves.—Double and Single Gate, 1/2 in. to
48 in., outside and inside Screws. Indica-
tor, etc., for Gas, Water, Steam, and Oil.
Send for Circulars.

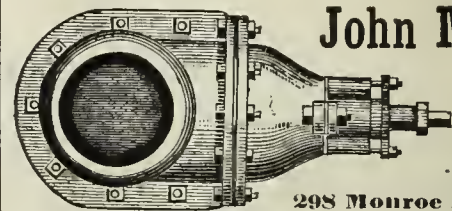

John McLean

Man'facturer

GAS
VALVES.

298 Monroe Street, N. Y.

SPECIAL TRAYS FOR IRON SPONGE OR OXIDE OF IRON.
CHURCH'S TRAYS A SPECIALTY.

REVERSIBLE—STRONGEST—MOST DURABLE—MOST EASILY REPAIRED.

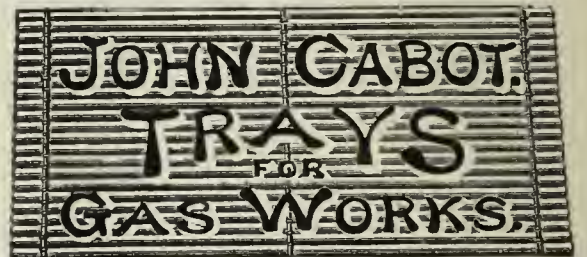

306-310 ELEVENTH AVENUE, NEW YORK.

WE ALSO MAKE THE CHEAPEST AND STRONGEST
REVERSIBLE BOLTED TRAYS IN THE MARKET.

VAN DUZEN GAS & GASOLINE ENGINE

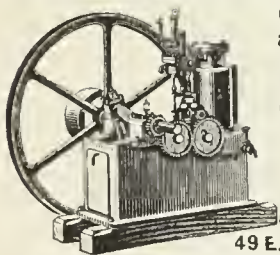

OPERATED with COAL
and OTHER MANUFAC-
TURED GASES AND
GASOLINE.

RELIABLE AND
ECONOMICAL.
Fully Warranted

VAN DUZEN
Gas & Gasoline Engine Co.
49 E. 2d St., Cincinnati, O.

A. MacKinnon Machine Co., Agts., 22 Warren St., N.Y.

The Management of Small Gas Works.

BY C. J. R. HUMPHREYS.

Price, \$1.

Orders to be sent to A. M. CALLENDER & CO.,

42 PINE STREET, NEW YORK.

THE CLERK GAS ENGINE CO.,

Main Office, 1012, 1014, 1016, 1018 Filbert St., Philadelphia, Pa.

WM. W. GOODWIN, Prest.

E. STEIN, Sec.

S. LEWIS JONES, Asst. Sec.

A. J. DOTY, Supt.

The utility and convenience of the Gas Engine being no longer an open question, it only remains now for intending purchasers to select the BEST. We claim for the CLERK GAS ENGINE that it is equal to any other manufactured as regards steadiness in running, simplicity, and ease of keeping in repair, and that it gives the greatest amount of power for the least money (both in first cost and expense of running) of any engine made. In support of this claim we refer to the test of the Gas Engines made under the direction of the American Institute of New York, in December, 1885, and heretofore published in these columns. These engines are especially adapted for continuous running under heavy loads, and we can refer to Engines which have run 22 hours a day for months at a time

Made in Sizes of 5 10 15 20, and 25 Horse Power. All Engines Guaranteed for One Year.

GAS STOVES.

GAS METERS.

GAS STOVES.

THE AMERICAN METER CO.,

MANUFACTURERS OF

GAS METERS, Station Meters,

METER PROVERS, PHOTOMETERS,
PRESSURE GAUGES OF ALL KINDS,



Standard 3 Diaphragm Dry Meter

AND



Standard 2 Diaphragm Dry Meter.

Apparatus for Testing the Quantity and Quality of Gases.

GAS STOVES FOR HEATING AND COOKING

Sole Agents in the United States for

Verity's Patent Gas Fires.

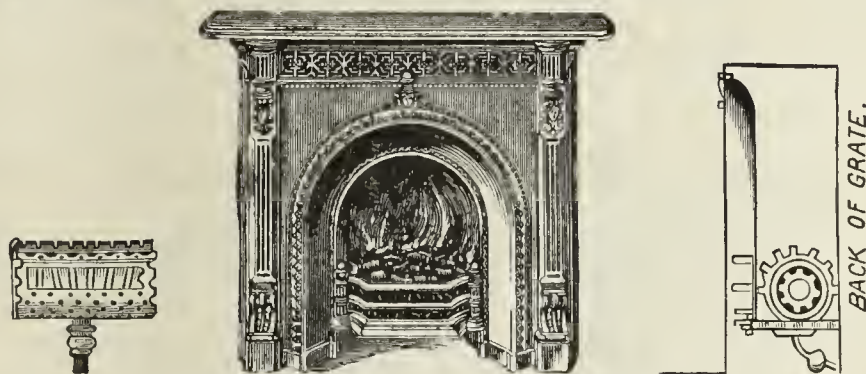

Circulars and Price Lists on Application.

MANUFACTORIES,

508 to 514 West Twenty-second St., N. Y.

Arch and Twenty-second St., Phila.

Nos. 244 & 246 North Wells Street, Chicago, Ill.

AGENCIES,

No. 177 Elm Street, Cincinnati, Ohio.

No. 222 Sutter Street, San Francisco, Cal.

No. 810 North Second Street, St. Louis, Mo.

GAS STOVE SHOW ROOMS, No 242 Sixth Avenue, New York City.

RETORTS AND FIRE BRICK.

J. H. GAUTIER & CO.,

CORNER OF

GREENE AND ESSEX STREETS,
JERSEY CITY, N. J.

MANUFACTURERS OF

**Clay Gas Retorts,
Gas House Tiles,
Fire Bricks, Etc. Etc.**

Ground Clay, Fire Brick and
Fire Sand in Barrels,

J. H. GAUTIER. C. E. GREGORY. C. E. GAUTIER.

BROOKLYN

Clay Retort & Fire Brick Works,
(EDWARD D. WHITE & CO.)

Manufacturers of Clay Retorts, Fire Brick,
Gas House and other Tile.

VAN DYKE, ELIZABETH, RICHARDS & PARTITION STS.
Office, 88 Van Dyke St., Brooklyn, N. Y.

RETORTS AND FIRE BRICK.

LACLEDE FIRE BRICK MFG. CO.,

MANUFACTURERS OF

Fire Brick, Gas Retorts,

AND

ST. LOUIS STANDARD SEWER PIPE.

Blast Furnace and Cupola Linings, every description of Fire
Clay Material, Fire Clay Flue Linings, Chimney Tops
Dry Milled and Crude Fire Clays, etc.

OFFICE AND DEPOT

901, 903, and 905 Pine Street,
ST. LOUIS, MO.

ESTABLISHED IN 1845.

B. KREISCHER & SONS,

OFFICE FOOT OF HOUSTON ST., E. B., N. Y.

Gas Retorts,

TILES, FIRE BRICK.

AND EVERYTHING IN THE FIRE CLAY LINE.

RETORTS AND FIRE BRICK.

MANHATTAN

FIRE BRICK & ENAMELLED CLAY

RETORT WORKS

ADAM WEBER.

CLAY GAS RETORTS

AND RETORT SETTINGS

FIRE BRICKS, TILES, ETC.,

Office and Works, 15th Street and Avenue C., N. Y.

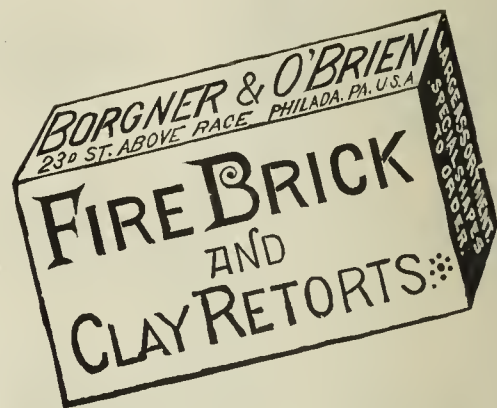

Works,

LOCKPORT STATION, PA.

—ESTABLISHED 1864.—

JAMES GARDNER, JR.,

Successor to WILLIAM GARDNER & SON.

Office, Rooms 19 & 20, Lewis Block,
PITTSBURGH, PA., P. O. Box 373.

Fire Clay Goods for Gas Works.

H. A. NORTON, No. 4 CENTRAL STREET, BOSTON, MASS., Agent for the New England States.

GEO. C. HICKS,
Prest.

CHICAGO

CHAS. A. REED,
Sec. & Treas.

Retort and Fire Brick Co.,

MANUFACTURERS OF

Fire Clay Goods of all Kinds,

AND BEST QUALITY ONLY.

Regenerative Furnaces & Water Gas Goods.

45th St., Clark to La Salle, Chicago.

GEROULD'S IMPROVED RETORT CEMENT.

A Cement for patching retorts, putting on mouthpieces, and
making up all bench-work joints. This Cement is mixed ready
or use. Economic and thorough in its work. Fully warranted
o stick. For recommendations and price list address

C. L. GEROULD & CO.,

5 & 7 Skillman St., Brooklyn, N. Y.

Western Agent, H. T. GEROULD, Mendota, Ill.

Parker-Russell

Mining and Mfg. Co.,

CITY OFFICE,

Mermod-Jaccard Bldg., Rooms 307 & 308,
Broadway & Locust St., St. Louis. Mo.

PROPRIETORS OF THE

OAKHILL GAS RETORT & FIRE BRICK W'KS

Our immense establishment is now employed almost entirely in
the manufacture of

Materials for Gas Companies

We have studied and perfected three important points. Our re-
torts are made to stand changes of temperature, the strongest
heats of the furnace, and the abrasion of feeding and emptying.
We have the exclusive Agency for the West of the celebrated

**Kloenne-Bredel Full Depth and
Semi-Recuperator Benches,**

And also furnish and build

Our Own Styles Semi-Recuperator Furnaces
for the use of Coal or Coke as fuel.

THOS. SMITH, Prest.

AUGUST LAMBLA, Vice-Prest. & Supt.

BALTIMORE

RETORT & FIRE BRICK CO.

MANUFACTORY AT

LOCUST POINT, BALTIMORE, MD.

Clay Retorts, Blocks & Tiles

**FIRE BRICK, FIRE CLAY,
AND FIRE CEMENT.**

Red and Buff Ornamental Tiles and Chim-
ney Tops. Drain and Sewer Pipe (from
2 to 30 inches). Baker Oven Tiles
12x12x2 and 10x10x2.

WALDO BROS., 88 WATER ST., BOSTON, MASS

Sole Agents the New England States.

Boston Fire Brick Works Manufacturers of **Gas Retorts and Settings**

Under the Personal Supervision of MR. GEO. C. HICKS late of Chicago.

Fire Clay Goods of all kinds. Akron Sewer Pipe, Lime, Cement, etc. Agts. for the Arc Gas Lamp & Governing Gas Burners.

Send for Circulars and Prices to

FISKE, COLEMAN & CO., Managers, No. 62 Congress Street, Boston, Mass.

HENRY MAURER & SON,

(ESTABLISHED 1856.)

**EXCELSIOR FIRE BRICK & CLAY
RETORT WORKS**

WORKS, Perth Amboy, N. J.
OFFICE, 118 to 422 East 23d St., N. Y.

**Clay Gas Retorts,
BENCH SETTINGS,
Fire Brick, Tiles, Etc.**

**FLEMMING'S
Generator-Gas Furnace**

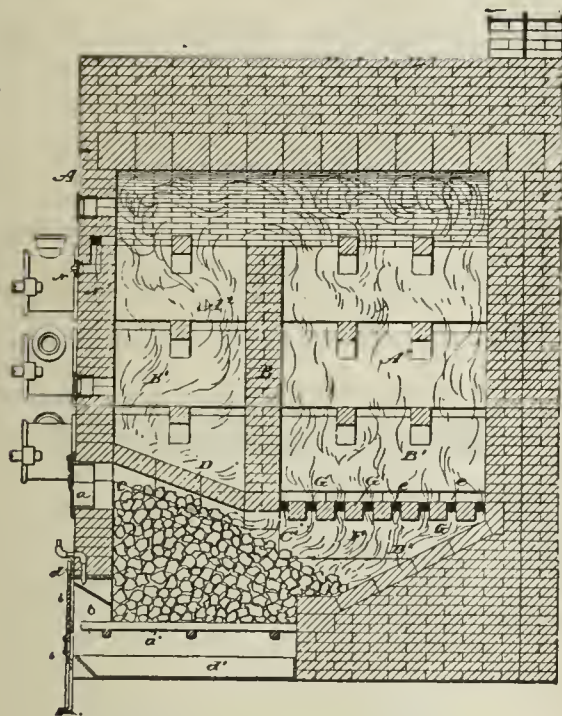

Materials furnished and Benches erected by

J. H. GAUTIER & CO., - Jersey City, N. J.

Address as above, or D. D. FLEMMING, Jersey City, N. J.

FRED. BREDEL,
CONTRACTOR FOR THE COMPLETE
Erection and Equipment of Gas Works.

SOLE PROPRIETOR OF THE

KLOENNE PATENTS

FOR NORTH AMERICA.

REGENERATIVE FURNACES.

(900 Retorts are now fired in America by the Kloenne-Bredel System.)

SELF-SEALING MOUTHPIECES.

(Over 800 Now in Use.)

Standard Condensers. Washer-Scrubbers.

TAR WASHERS FOR WATER GAS PLANTS.

(In use in the works of the Chicago Gas Lt. Co.)

GASHOLDERS.

Bredel's Automatic Gas Governor.

Refers, by permission, to Mr. Eugene Vanderpool, Newark, N. J.; Mr. E. G. Cowdery, Milwaukee, Wis.; and Mr. Theo. Forstall, Chicago, Ills. For further information, address

FRED. BREDEL,
No. 208 East Seventeenth Street, N. Y. City.

<p>COMPOUND Condensing or Non-Condensing. 16 SIZES, 5 to 500 H. P. Not yet equaled by any form of Engine for HIGH FUEL DUTY AND SIMPLICITY.</p> <p>STANDARD 13 Sizes in Stock. 5 to 250 H. P. 3000 in use in all parts of the Civilized World.</p> <p>JUNIOR 6 Sizes in Stock, 5 to 50 H. P. An Automatic Engine cheaper than a Slide Valve. WELL BUILT. ECONOMICAL. RELIABLE. Over 300 Sold the First Year.</p> <p>All the above built strictly to Gauge with INTERCHANGEABLE PARTS. REPAIRS CARRIED IN STOCK. SEND FOR ILLUSTRATED CATALOGUES.</p>	<p>WESTINGHOUSE ENGINES The Westinghouse Machine Co. PITTSBURGH, PA. U.S.A.</p>	<p>SELLING DEPARTMENT IN THE UNITED STATES.</p> <table border="0"> <tr> <td>New York,</td> <td>17 Cortlandt St.</td> <td rowspan="3">} Westinghouse, Church, Kerr & Co.</td> </tr> <tr> <td>Boston,</td> <td>Hathaway Building,</td> </tr> <tr> <td>Pittsburgh,</td> <td>Westinghouse Build'g,</td> </tr> <tr> <td>Chicago,</td> <td>156, 158 Lake St.</td> <td></td> </tr> <tr> <td>Philadelphia,</td> <td>608 Chestnut St. M. R. Muckle, Jr. & Co.</td> <td></td> </tr> </table> <p>ST. LOUIS, 511 NORTH FOURTH ST., Westinghouse, Church, Kerr & Co.</p> <table border="0"> <tr> <td>Salt Lake City,</td> <td>259 S. Main St. }</td> <td>Utah & Montana</td> </tr> <tr> <td>Butte, Mont.</td> <td>1. Granite St. }</td> <td>Machinery Co.</td> </tr> <tr> <td>San Francisco,</td> <td>24, 23 Fremont Street,</td> <td>Parke & Lacy Co.</td> </tr> <tr> <td>Portland, Or.</td> <td>33, 35 N. Front St.</td> <td>Parke & Lacy Mch. Co.</td> </tr> <tr> <td>Charlotte, N. C.</td> <td>36 College St. }</td> <td rowspan="2">The D. A. Tompkins Co.</td> </tr> <tr> <td>Atlanta, Ga.</td> <td>45 S. Prior St. }</td> </tr> <tr> <td>Dallas, Tex.</td> <td></td> <td>Keating Imp. & Machine Co.</td> </tr> <tr> <td>Chattanooga, Tenn.,</td> <td></td> <td>C. E. James & Co.</td> </tr> </table>	New York,	17 Cortlandt St.	} Westinghouse, Church, Kerr & Co.	Boston,	Hathaway Building,	Pittsburgh,	Westinghouse Build'g,	Chicago,	156, 158 Lake St.		Philadelphia,	608 Chestnut St. M. R. Muckle, Jr. & Co.		Salt Lake City,	259 S. Main St. }	Utah & Montana	Butte, Mont.	1. Granite St. }	Machinery Co.	San Francisco,	24, 23 Fremont Street,	Parke & Lacy Co.	Portland, Or.	33, 35 N. Front St.	Parke & Lacy Mch. Co.	Charlotte, N. C.	36 College St. }	The D. A. Tompkins Co.	Atlanta, Ga.	45 S. Prior St. }	Dallas, Tex.		Keating Imp. & Machine Co.	Chattanooga, Tenn.,		C. E. James & Co.
New York,	17 Cortlandt St.	} Westinghouse, Church, Kerr & Co.																																				
Boston,	Hathaway Building,																																					
Pittsburgh,	Westinghouse Build'g,																																					
Chicago,	156, 158 Lake St.																																					
Philadelphia,	608 Chestnut St. M. R. Muckle, Jr. & Co.																																					
Salt Lake City,	259 S. Main St. }	Utah & Montana																																				
Butte, Mont.	1. Granite St. }	Machinery Co.																																				
San Francisco,	24, 23 Fremont Street,	Parke & Lacy Co.																																				
Portland, Or.	33, 35 N. Front St.	Parke & Lacy Mch. Co.																																				
Charlotte, N. C.	36 College St. }	The D. A. Tompkins Co.																																				
Atlanta, Ga.	45 S. Prior St. }																																					
Dallas, Tex.		Keating Imp. & Machine Co.																																				
Chattanooga, Tenn.,		C. E. James & Co.																																				

Newbigging's Handbook for Gas Engineers and Managers.

The present (the fifth) edition marks an important advance on those that have gone before. Considerable additions have been made to the text, and much of it has been re-written and otherwise improved. It extends to 524 pages, and contains 193 illustrations. Price, Cloth, \$6.00.

A. M. CALLENDER & CO., No. 42 Pine Street, N. Y. City.

GAS AND WATER PIPES.

GAS AND WATER PIPES.

ENGINEERS.

SAM'L R. SHIPLEY, Pres.
HENRY B. CHEW, Tre

JAS. P. MICHELLON, Sec.
WM. SEXTON, Supt.

GLOUCESTER IRON WORKS,
GLOUCESTER CITY, N. J.



Cast Iron Gas & Water Pipes, Stop Valves, Fire Hydrants, Gasholders. &c.
Office, Rooms 61 and 63 Bullitt Building, 131 S. 4th St., Phila., Pa.

WARREN FOUNDRY AND MACHINE CO.,

Established 1856. Works at Phillipsburgh. N. J.

New York Office, 160 Broadway.

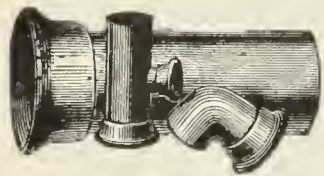

CAST IRON WATER AND GAS PIPE,

FROM TWO TO FORTY-EIGHT INCHES DIAMETER. ALSO, ALL SIZES OF

Flange Pipe for Sugar House and Mine Work. Branches, Bends, Retorts, etc., etc.

DENNIS LONG & COMPANY,

LOUISVILLE, KY.,



Manufacture Exclusively

CAST IRON GAS & WATER PIPE & SPECIAL CASTINGS
OF ALL SIZES.

King's Treatise on Coal Gas.

A standard text-book for the Engineers and Managers of Gas Works, and for all who are concerned or take an interest in the manufacture and distribution of Coal Gas, and in the utilization of the Secondary Products resulting therefrom; treating also of the Gas Engine, and of Gas Cooking and Heating Appliances.

In 3 Vols. Price per Vol., \$10. Sold either by Volume or in Sets.

A M. CALLENDER & CO., 42 Pine St., N. Y.

P. D. WANNER, Chairman. A. H. MELLERT, Mangr. of Wks.
R. B. KINSEY, Secretary. F. A. KNOPP, Treasurer.

MELLERT FOUNDRY & MACHINE CO. Ltd.
and **READING FOUNDRY CO., Ltd.**
Reading, Pa.



Specials—Flange Pipe, Valves and Hydrants
Lamp Posts, Retorts, etc.

General Foundry and Machine Work.
JOHN FOX, Selling Agent. 160 Broadway, N.Y.

THE OHIO PIPE COMPANY,

MANUFACTURERS OF

Cast Iron Gas & Water Pipe,
BRANCH AND SPECIAL CASTINGS.

Gas-House Bench Castings, Hydraulics, Lamp Posts, Flange Pipe
and Specials, Architectural Castings, Building Columns,
Joists, Cellar Grates, Sash Weights, etc.

GENERAL FOUNDERS AND MACHINISTS.
Columbus, Ohio.

M. J. DRUMMOND,



SPECIAL CASTINGS AND LAMP POSTS.

Office, Corbin Building, 192 Broadway, N. Y.

EMAUS PIPE FOUNDRY.

DONALDSON IRON COMPANY. EMAUS, PA.



MANUFACTURERS OF

CAST IRON PIPE AND SPECIAL CASTINGS
FOR WATER AND GAS.

JOS. R. THOMAS,

No. 42 Pine Street, N.Y. City.

CONSULTING AND CONSTRUCTING
Gas Engineer and Contractor.

PLANS, SPECIFICATIONS, AND ESTIMATES
FURNISHED.

Contracts taken for all Appliances
required at a Gas Works,
Either for New Works or Extensions to Old Plants.

WM. MOONEY

(Successor to WM. FARMER)

No. 94 Liberty St., N Y. City.

GAS ENGINEER AND CONTRACTOR FOR THE ERECTION
OF GAS WORKS, OR APPARATUS OF ANY
CAPACITY.

Plans and Specifications Furnished.

WM. GARDNER,
Gas Engineer,

Lewis Block, Room 20, Pittsburgh, Pa.

Those who intend to make alterations in existing gas plants, or who contemplate the erection of new works, will find it to their interest to open correspondence with the above. Plans made and estimates furnished.

BARTLETT, HAYWARD & CO.

Baltimore, Md.

Triple Double, & Single-Lift
GASHOLDERS.

Iron Holder Tanks.

ROOF FRAMES.

Cirders.

BEAMS.

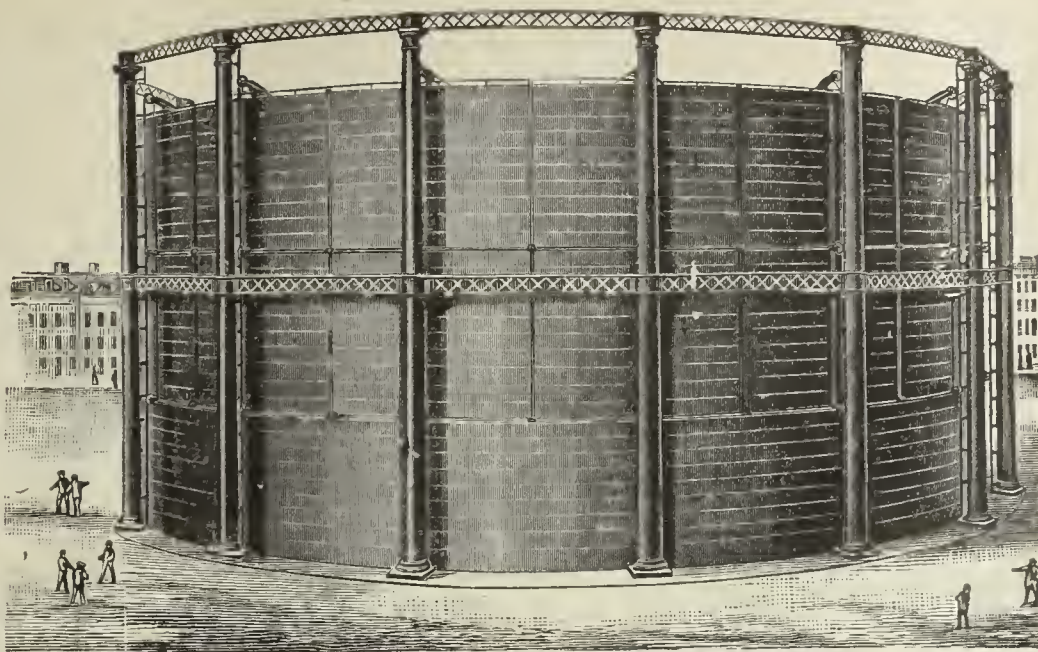

PURIFIERS.

CONDENSERS.

Scrubbers.

BENCH CASTINGS.

OIL STORAGE TANKS.

Boilers.

The Wilkinson Water Gas Process.

THIRTY-CANDLE, NON-CONDENSABLE, FIXED GAS. THE MOST SUCCESSFUL GAS PROCESS IN OPERATION.

Munich Regenerative Furnace, System Drs. Schilling & Bunte.

HAZELTON BOILERS.

Gas Works Designed and Constructed.

Pascal Iron Works. ESTABLISHED 1821. Delaware Iron Works.

MORRIS, TASKER & CO.,

INCORPORATED.

OFFICE, 224 SOUTH THIRD STREET, - - PHILADELPHIA, PA.

CONTRACTORS, BUILDERS, AND MANUFACTURERS OF

Gas, Water & Sugar Works

Bench Castings.

Condensers.

Scrubbers.

Purifiers.

Hyd. Carriages.

Iron Floors,

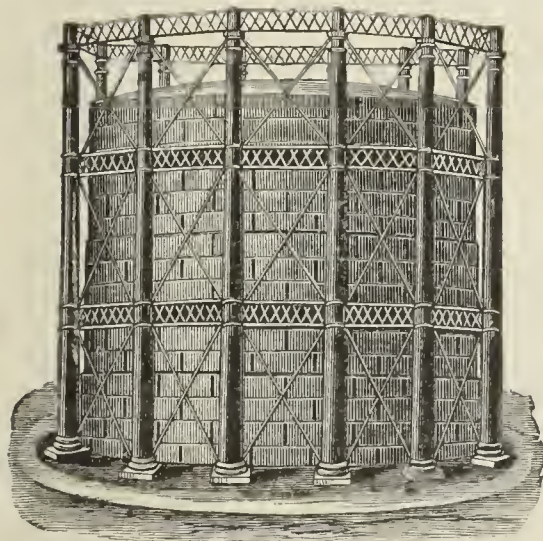

Iron Roofs.

Street Stops,

Valves, etc.

Stand-Pipes.

Water & Oil

Tanks, all Sizes.

Single, Double, and Triple-Lift Gas Holders.

SELF-SEALING RETORT LIDS. STAMPED STEEL RETORT LIDS.

Locomotive Water Columns, Filters, etc. Boiler Tubes, Wrought Iron Pipe & Fittings

Plans, Specifications and Estimates for all kinds of Machinery furnished on application.

Foundries & Works,
MILLVILLE, FLORENCE,
and CAMDEN, N. J.

R. D. WOOD & CO.,

Engineers,
Iron Founders,
and
Machinists.

400 Chestnut St., PHILADELPHIA, PA.

MANUFACTURERS OF

CAST IRON PIPE,

Gas Holders,

SINGLE, DOUBLE, AND TRIPLE LIFTS, WITH
OR WITHOUT WROUGHT IRON
OR STEEL TANKS.

PURIFIERS, CONDENSERS.

Scrubbers.

BENCH WORK.

Iron Floors and Roofs, Plate Girders.

Heavy Loam Castings.

HYDRAULIC WORK.

Lamp Posts, Valves, Etc.

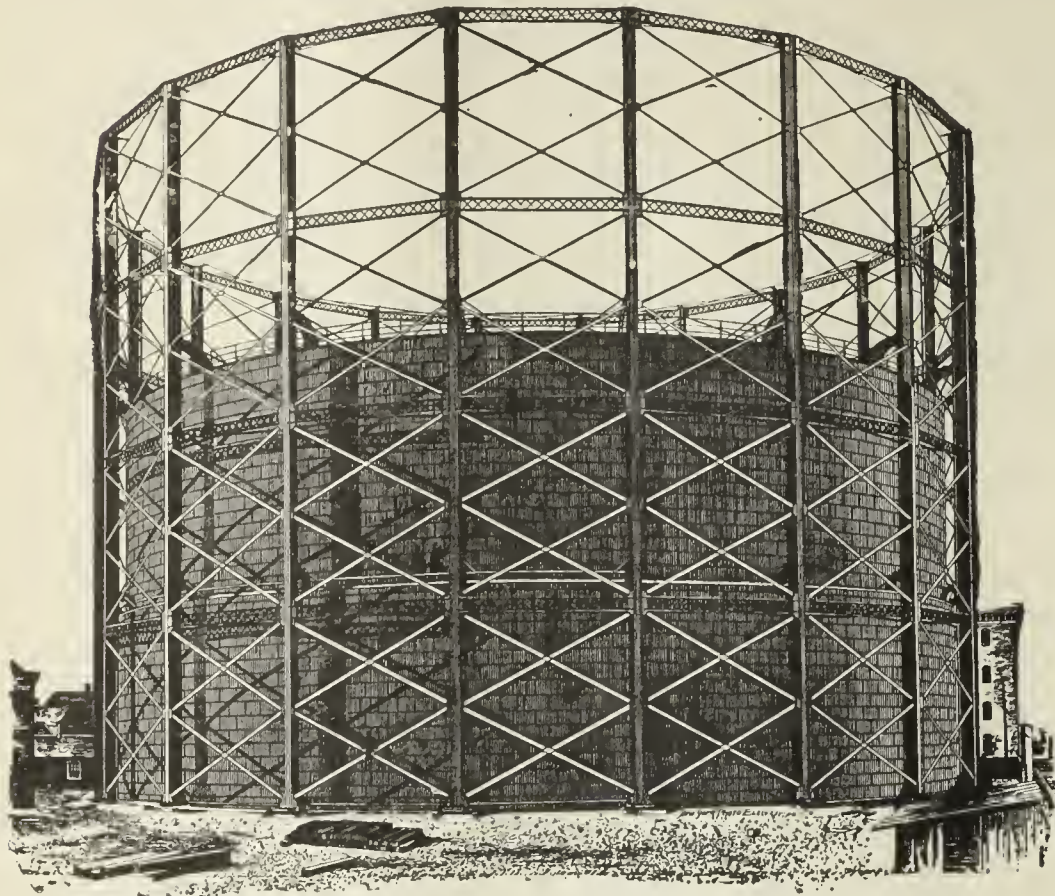

SMITH & SAYRE MFG. COMPANY,

G. G. PORTER, Prest.

245 Broadway, N. Y.

CHAS. W. ISBELL, Sec'y.

Machinery & Apparatus for Gas Works

Drawings, Plans, and Estimates Furnished for the Improvement, Extension, or Alteration of Gas Works, or for the Construction of New Works.

Mackenzie's Patent Rotary and Steam Jet Gas Exhausters, Governors, Compensators, Condensers, Washers, Scrubbers. Isbell's Patent Automatic Street Pressure Governor, Gas and Water Valves, Hydraulic Main Dip Regulator, Bench Castings, etc. Purifying Boxes and "Standard" Scrubbers. Isbell's Patent Self-Sealing Retort Doors.

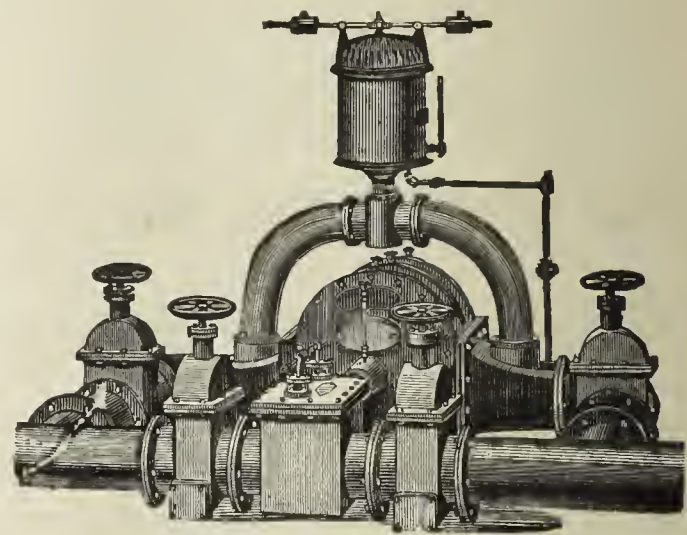

THE BRENNER SELF-SEALING RETORT DOOR.

Simple, Strong, and Durable.

CLOSES ABSOLUTELY TIGHT & IS LOCKED BY A CAM LEVER. ALL NECESSARY ADJUSTMENT FOR WEAR PROVIDED.

BUILT BY

SMITH & SAYRE MFG. CO.,

No. 245 Broadway, - - - - New York City.

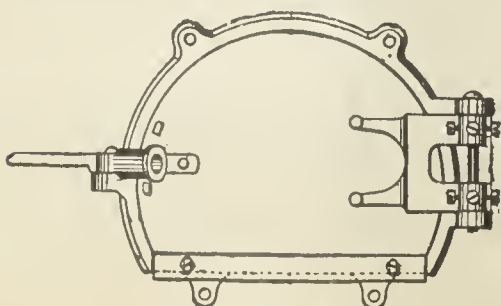

Brenner Self-Sealing Retort Door.

WILLIAM B. LUNDIE, Superintendent of the 42d Street Station of the Consolidated Gas Company, of New York, writes, under date of Jan. 4, 1889:

"We have 320 Brenner Self-Sealing Lids in use at this Station, built by the Smith & Sayre Mfg. Co. They require very little attention, and are the best of the kind that I have seen, giving entire satisfaction."

GAS WORKS APPARATUS AND CONSTRUCTION.

GAS WORKS APPARATUS AND CONSTRUCTION.

JAMES R. FLOYD & SONS,

(SUCCESSORS TO HERRING & FLOYD)

Oregon Iron Works,

W. 20th & 21st. Sts., bet. 10th & 11th Avs.,

NEW YORK CITY.

Engineers and Contractors

FOR THE

CONSTRUCTION OF GAS WORKS.

MANUFACTURERS OF

All Kinds of Castings and General Ironwork

FOR

GAS APPARATUS.

Bench Castings, Regenerative and Half Regenerative Furnace Castings.

Condensers, Scrubbers, Purifiers, Street Drips and Connections,

Valves,

Hydraulic Hoisting Purifier Carriage, Self-Sealing Retort Lids, Improved Valve Stand and Indicator,

Seller's Cement.

Plans, Specifications, and Estimates furnished for Construction of New or Alteration of Old Works.

CONTINENTAL IRON WORKS.

THOS. F. ROWLAND, Prest.

WARREN E. HILL and CHAS. H. CORBETT, V-Prests.

THOS. F. ROWLAND, JR., Sec. & Tr

P. O. Station G., BROOKLYN, N. Y.

ENGINEERS AND MANUFACTURERS OF

Gas Holders

CONDENSERS, SCRUBBERS, VALVES,

PURIFIERS, SELF-SEALING RETORT LIDS!

Hydraulic Mains,

And all other articles connected with the manufacture and distribution of Gas.

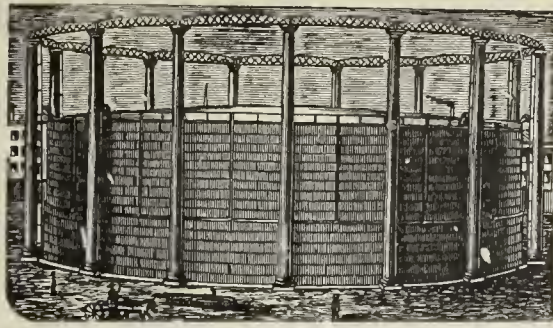

H. RANSHAW, Prest. & Mangr.

WM. STACEY, Vice-Prest.

T. H. BIRCH, Asst. Mangr.

R. J. TARVIN, Sec. & Treas.

STACEY MFG. CO.,

MANUFACTURERS OF

Single and Telescopic Gasholders,

IRON ROOFS, BRIDGES, LAMP POSTS,

Water and Oil Tanks, Coal Elevator Cars,

COKE CRUSHERS, BENCH CASTINGS,

And all kinds of Wrought and Cast Iron Work used in the erection of Coal and Oil Gas Works Rolling Mill Machinery and Heavy Castings a Specialty.

Foundry:

33, 35, 37 & 39 Mill Street.

Wrought Iron Works:

16, 18, 20, 22, 24 & 26 Ramsey Street:

Cincinnati, Ohio.

Bouton Foundry Co.,

FOUNDERS AND MACHINISTS,

CHICAGO, ILL.

Gas Works Apparatus,

PURIFIERS, CONDENSERS,

Bench Work

SPECIALS, LAMP POSTS,

SCRUBBERS,

Iron Roofs and Floors.

Plans and Estimates furnished for new works or extensions of old works.

1842. **DEILY & FOWLER,** 1889.

Laurel Iron Works.

Address, No. 39 Laurel Street, Philadelphia, Pa.

BUILDERS OF

GASHOLDERS,

Single and Telescopic.

Holder Built 1884 to 1888, Inclusive:

- | | | | | |
|----------------------------|-----------------------------|---------------------------|--------------------------|------------------------|
| Newport, R. I. | Long Island City, N. Y. | Port Chester, N. Y. | Malden, Mass. | West Chester, Pa. (2d) |
| Portland, Oregon. | Macon, Ga. | New Rochelle, N. Y. | Paducah, Ky. | Lancaster, Pa. (3d) |
| Allegheny, Pa. (2d.) | York, Pa. | Salem, N. J. (3d) | Norwich, Conn. | Tacoma, Pa. (two) |
| Atlanta, Ga. (2d.) | Chester, Pa. | Omaha, Neb. (2d) | Seattle, W. T. | Mount Vernon, N. Y. |
| N.Y. City (Central Gas Co) | Hazleton, Pa. (2d.) | Lynn, Mass. (2d) | San Diego, Cal. | Binghamton, N. Y. |
| Lynchburg, Va. (2d.) | State Island, N. Y. | Little Rock, Ark. | Northern Gas Lt. Co., of | Concord, N. H. |
| Saylesville, R. I. | Saugerties, N. Y. | Irrington, N. Y. | New York, N. Y. | Dover, Del. (2d) |
| Rondout, N. Y. | Clinton, Mass. (Lan. Mills) | South Boston, Mass. | Westerly, R. I. | Calais, Me. |
| Atlantic City, N. J. | Chattanooga, Tenn. | Rye, N. Y. (2) | Willimantic, Conn | New London, Conn. (2d) |
| Augusta, Ga. | Galveston, Texas. (3d.) | Woodstock, Ont. | Montclair, N. J. | West Chester, N. Y. |
| Waltham, Mass. (2) | Omaha, Neb. | Malden, Mass. | Attleboro, Mass. | Bay Shore, L. I. |
| Mahanoy City, Pa. | Fort Plain, N. Y. | Staten Island, N. Y. (2d) | Santa Cruz, Cal. | Washington, D. C. |
| New Castle, Pa. | Brunswick, Ga. | Woodstock, Ont. | Erie, Pa. (2d) | |

WM. HENRY WHITE,

No. 32 Pine Street, - - - New York City.

ENGINEER AND CONTRACTOR FOR THE

Erection and Extension of Gas, Water, and Electric Light Works.

SOLE REPRESENTATIVE OF THE

McILHENNY REGENERATOR FURNACE PATENTS

And the Martin Water Gas Process.

Edison Incandescent and American Arc Electric Light Plants Installed.

Correspondence with Gas Companies contemplating extending or improving their Plants respectfully invited. Plans and Estimates Furnished.

GAS COALS.

CANNEL COALS.

GAS ENRICHERS.

JAMES D. PERKINS. **PERKINS & CO.,** F. SEAVERN.
 228 & 229 Produce Exchange, New York.
 Cable Address, "PERKINS, NEW YORK." Post Office Box 3695, New York.

GENERAL SALES AGENTS FOR

The Youghiogeny River Coal Company's
OCEAN MINE YOUGHIOGHENY GAS COAL.
 HON. W. L. SCOTT, Prest. M. H. TAYLOR, Vice-Prest.

This Colliery is located at SCOTT HAVEN, PA., in the center of the Youghiogeny Gas Coal District, and produces the ONLY RELIABLE YOUGHIOGHENY COAL for gas purposes. (See Map on p. 87 of this JOURNAL, Feb. 16, '85.)

POINTS OF SHIPMENT,

Locust Point, BALTIMORE. Pier No. 62, PHILADELPHIA.

Also, SOLE AGENTS for the

BRECKENRIDGE CANNEL, OF KENTUCKY.

Within the past two years we have delivered this Cannel to over ONE HUNDRED COMPANIES IN THIRTY, THREE DIFFERENT STATES, and it is now in use in some of the large Gas Works

On the Continent and in South America,

where it successfully competes with the Australian Shale. It is the ONLY AMERICAN GAS CANNEL of sufficiently high grade to warrant EXPORTATION TO EUROPE AND SOUTH AMERICA, and it is the only economical substitute for OIL OR NAPHTHA. ONE GROSS TON will produce

10,000 Cubic Feet of 75 Candle Gas,	} equal to {	750,000 Candle Feet of Gas, and 26 Bushels of merchantable Coke weighing 900 Pounds
or 12,500 " " 60 " "		
or 15,000 " " 50 " "		

This is the ONLY GAS CANNEL that will produce a REALLY MERCHANTABLE COKE. It can be delivered in parcels of one carload or more to any point in the United States or Canada. Cargo shipments of any size required can be made from NEW YORK, PHILADELPHIA, BALTIMORE, or NEWPORT NEWS. Samples will be sent and particulars of price, etc., forwarded upon application to above address.

JAMES & WILLIAM WOOD,
Gas and Cannel Coal Contractors,

No. 40 St. Enoch Sq., Glasgow. No. 2 Talbot Court, London.

Proprietors of the BATHVILLE COLLIERIES (which produce the celebrated BOGHEAD CANNEL), Shields, Shieldmuir, Drumpeller, and other Collieries. This Firm offer

STANDARD CANNELS,

Unequaled as Gas Enrichers.

Also, WEST FAIRMONT GAS COAL, of W. Va.

Analyses, prices, and all further information furnished on application to
 Agency for U.S., Room 70, Nos. 2 & 4 Stone St., N.Y. C ty.

The Standard Oil Company,

REFINERS OF

NAPHTHA AND GASOLINES.

ALSO MANUFACTURERS OF

A Special Grade of Naptha for
 Gas Companies

FOR ENRICHING COAL GAS.

Correspondence solicited.

No. 43 Euclid Avenue, Cleveland, Ohio.

To Gas Companies.

We make to order CAP BURNERS to burn any amount under a stated pressure. Send for samples.

Also, SERVICE CLEANERS, DRIP PUMPS, and STREET MAIN PROVING APPARATUS.

C. A. GEFROER,

248 N 8th Street, Phila., Pa.

COKE CRUSHERS.

Newburgh Orrel Coal and Coke Co.
 MINERS AND SHIPPERS OF
STEAM, SMITHING, AND GAS COALS,
 Foundry and Crushed Coke.
 Home Office, 33 S. Gay Street, Baltimore, Md.
J. HARRY LEE, President.
 Shipping Wharves, Locust Point, Baltimore.

The Despard Gas Coal Co.,
 MINERS AND SHIPPERS OF
DESPARD GAS COAL,
 AND MANUFACTURERS OF
COKE.
 MINES, Clarksburg, Harrison Co., W. Va.
 WHARVES, Locust Point, Baltimore, Md.
 OFFICE, 225 E. German St., " "
 ROUSSEL & HICKS, } AGENTS. } BANGS & HORTON,
 71 Broadway, N. Y. } 60 Congress St., Boston.

GAS COALS.

GAS COALS.

THE
PENN GAS COAL CO.

OFFER THEIR

Coal, Carefully Screened & Prepared for Gas Purposes

Their Property is located in the Youghiogheny Coal Basin, near Irwin and Penn Stations on the Pennsylvania Railroad, and on the Youghiogheny River.

Principal Office:

209 SOUTH THIRD STREET, PHILA., PA.

Points of Shipment:

Pennsylvania Railroad Piers; Greenwich Wharves, Delaware River; Pier No. 1 (Lower Side), South Amboy, N. J.

Chesapeake & Ohio Railway Coal Agency,

FOR THE SALE OF THE

Superior Kanawha Gas Coals, Cannelton Cannel,
Also, SPLINT AND STEAM COALS
 From the Kanawha and New River Regions, on the line of the Chesapeake & Ohio R'way.
C. B. ORCUTT, General Agent, - - No. 1 Broadway (Room 217) New York City.

FRANCIS H. JACKSON, Pres't EDMUND H. MCCULLOUGH, V.-Pres't. CHAS. F. GODSHALL, Treas. H. C. ADAMS, Sec.

THE WESTMORELAND COAL CO.

Chartered 1854.

Mines situated on the Pennsylvania and the Baltimore and Ohio Railroads, in Westmoreland County, Penn.

POINTS OF SHIPMENT:

PHILADELPHIA, BALTIMORE, SOUTH AMBOY, N. J.,
 WATKINS (SENECA LAKE), N. Y.

Since the commencement of operations by this Company its well-known Coal has been largely used by the Gas Companies of New England and the Middle States, and its character is established as having no superior in gas-giving qualities, and in freedom from sulphur and other impurities.

Principal Office, 224 South 3d St., Phila., Pa.

**The American Gas Engineer
 and Superintendent's Handbook**

By WILLIAM MOONEY.

Consisting of Rules, Reference Tables, and Original Matter Pertaining to the Manufacture, Manipulation, and Distribution of Illuminating Gas.

350 Pages, Full Gilt Morocco.

\$3.00.

A. M. CALLENDER & CO., 42 Pine St., N. Y.

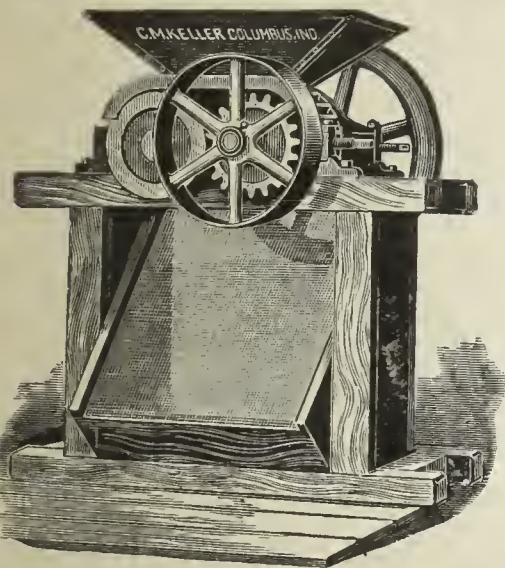

Keller's Adjustable Coke Crusher
 SIMPLE, STRONG, AND DURABLE.

C. M. Keller, Sec. & Supt. Gas Lt. & Coke Co. Columbus, Ind
 Correspondence Solicited.

King's Treatise on Coal Gas.

The most complete work on Coal Gas ever published.

Three Vols. Bound, \$30.

BOOKS.

DISTILLATION OF COAL TAR AND AMMONIACAL LIQUOR.

By GEORGE LUNGE. Price \$12.50.

A TREATISE ON THE COMPARATIVE COMMERCIAL VALUES OF GAS COALS AND CANNELS.

By DAVID A. GRAHAM. 8vo., Cloth. Price \$3.

Orders for these books may be sent to this office.

A. M. CALLENDER & CO.,

42 PINE ST., N. Y. CITY

JOHN J. GRIFFIN & CO.,

Nos. 1513, 1515, 1517 & 1519 Race Street, PHILADELPHIA.
52 Dey St., NEW YORK. 75 N. Clinton St., (FRED. R. PERSONS, Mangr.) CHICAGO.

MANUFACTURERS OF

METERS FOR MEASURING GAS

IN ANY VOLUME.

Provers, Gauges, Registers, Etc., Etc.

EXPERIMENTAL APPARATUS FOR QUANTITATIVE AND QUALITATIVE ANALYSIS.

Careful and Prompt Attention paid to Repairing of all kinds of Meters and Apparatus.

Estimates Cheerfully Furnished.

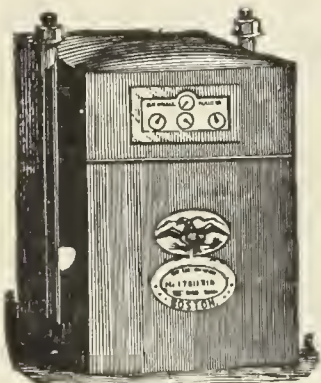

Dry Gas Meters.

With 40 years' experience and the best facilities for manufacturing, is enabled to furnish reliable work and answer orders promptly.

NATHANIEL TUFTS,

No. 153 Franklin Street, Boston, Mass.,

MANUFACTURER OF

DRY GAS METERS.

Station Meters of any Capacity.

Test and Experimental Meters, Pressure Registers, Pressure Gauges, Pressure and Vacuum Gauges.

METER PROVERS, PHOTOMETERS, STREET LANTERNS, ETC., ETC.

Patent Cluster Lanterns for Street Illumination.

HAROLD J. BELL.

BELL & JONES,

S. LEWIS JONES.

No. 12 North Ninth Street, Philadelphia, Pa. Works at Royersford, Pa.

MANUFACTURERS OF

GAS METERS, STATION AND EXPERIMENTAL METERS,
Meter Provers, Pressure Gauges, and All Other Gas Appliances in Our Line.

WE REPAIR ALL KINDS AND MAKES OF METERS, AND THE WORK GUARANTEED.

High Pressure Meters for Natural Gas, in Iron Cases, guaranteed to stand 300 lbs. Pressure.
Gas Cooking and Heating Stoves, Hot Plates, Cake Griddles, Waffle Bakers, Boiling Stoves, Laundry and Tailors' Iron Heaters. Hotel and Cafe Ranges a Specialty.

Correspondence Solicited.

Estimates Furnished.

A. HARRIS.

E. L. HARRIS.

J. A. HARRIS.

Established 1849.

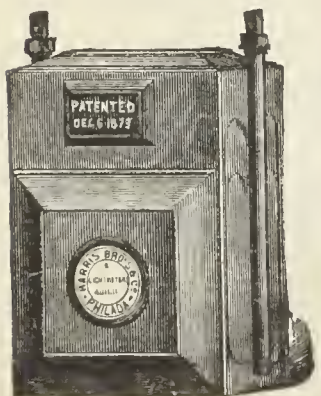

HARRIS BROS. & CO.,

Twelfth and Brown Streets, Philadelphia.

Manufacturers of Wet and Dry Gas Meters,

STATION METERS, METER PROVERS,

EXPERIMENTAL METERS, SHOW OR GLAZED METERS,

Pressure and Vacuum Registers, Gauges, Photometers, Drip and Bell Pumps, Etc., Etc.

PROMPT ATTENTION GIVEN TO ALL ORDERS. METERS THOROUGHLY REPAIRED. ESTIMATES FURNISHED FOR STATION METERS OF ALL SIZES. CORRESPONDENCE SOLICITED.

GAS METERS.

GAS METERS.

GAS METERS.

GEO. J. MCGOURKEY, Prest.

WM. H. MCFADDEN, Vice-Prest. (Phila.)

WM. N. MILSTED, Gen. Supt. and Treas. (New York).

WM. H. DOWN, Sec.

THE AMERICAN METER CO.

WET AND DRY GAS METERS.

PRESSURE REGISTERS.

METER PROVERS.

STATION METERS.

PRESSURE & VACUUM REGISTERS.

PORTABLE TEST METERS.

EXHAUSTER GOVERNORS.

PRESSURE & VACUUM GAUGES.

EXPERIMENTAL METERS.

DRY CENTER VALVES.

CRESSON GAS REGULATORS.

AMMONIA TEST METERS.

GOVERNORS FOR GAS WORKS.

MARSLAND WATER METERS.

BAR & JET PHOTOMETERS.

Manufactories:

512 West 22d St., N. Y.
Arch & 22d Sts., Phila.

GAS STOVES.

SUGG'S "STANDARD" ARGAND BURNERS,
SUGG'S ILLUMINATING POWER METER,
Wet Meters; with Lizar's "Invariable Measuring" Drum.

Agencies:

177 Elm Street, Cincinnati.
244 & 246 N. Wells Street, Chicago.
510 North Second Street, St. Louis.
222 Sutter Street, San Francisco.

HELME & McILHENNY,

(Established 1848.)

GAS METER MANUFACTURERS,

Nos. 1339 to 1349 Cherry Street, Philadelphia, Pa.,

WET AND DRY GAS METERS, STATION METERS, EXPERIMENTAL METERS, METER PROVERS,

Center Seals, Pressure Registers, Governors, Indicators, Photometers, and all other kinds of Apparatus for use in Gas Works.

FOULIS' PATENT STATION AND DISTRICT GOVERNORS.

REPAIRING DEPARTMENT.—We employ a special force of skilled workmen repairing meters of all makers.

WM. WALLACE GOODWIN, President and Treasurer.

E. STEIN, Vice-President.

H. B. GOODWIN, Secretary and Superintendent.

THE GOODWIN GAS STOVE AND METER CO.,

Successors to W. W. GOODWIN & CO.

1012, 1014 and 1016 Filbert St., Phila., Pa.

142 Chambers St., New York City.

76 Dearborn, St., Chicago, Ill.

WALDO BROTHERS, Agents, 88 Water Streets, Boston, Mass.

MANUFACTURERS OF

DRY AND WET GAS METERS,

Station Meters (square, cylindrical, or in staves), Glazed Meters, King's and Sugg's Experimental Meters, Lamp Post Meters, etc., etc. Meter Provers (sizes 2, 5, and 10 feet), Pressure Gauges of all kinds, Pressure Registers, Pressure and Vacuum Registers, Pressure Indicators (sizes 4, 6, and 9 inch), King's Pressure and Vacuum Gauges, Dry and Wet Center Seals, Dry and Wet Governors, Exhauster Governors, Photometers of all descriptions. Letheby's Sulphur and Ammonia Test Apparatus complete. Also, Testing and Chemical Apparatus of all kinds, and of the most perfect description, for all purposes relating to Gas.

Manufacturers of the "SUN DIAL" GAS STOVES, for Cooking and Heating.

Goodwin's Improved Lowe's Jet Photometer.

Agents for Bray's Patent Gas Burners and Lanterns.

Special attention to Repairs of Meters and all Apparatus connected with the business. All work guaranteed first-class in every particular. Orders filled promptly.

G. B. EDWARDS, Manager, New York.

S. S. STRATTON, Manager, Chicago.

D. McDONALD & CO.,

GAS METER MANUFACTURERS.

(Established 1854.)

51 Lancaster St., Albany, N. Y. 34 & 36 West Monroe St., Chicago, Ill.

STATION METERS, EXPERIMENTAL METERS, METER PROVERS, PRESSURE & VACUUM REGISTERS, PRESSURE GAUGES, ETC

Also STAR GAS STOVES, RANGES, and HEATING STOVES.

We use only the very best materials, and employ the most skilled labor, and by our long experience (32 years) and personal supervision of every detail, we feel justified in assuring the public that our goods will give perfect satisfaction. Every Meter emanating from our establishment will bear the State Inspector's BADGE, and will be fully warranted by us. Our Annual and Calendar will be sent to Gas Companies upon application.

GAS INTO POWER,

BY THE

OTTO GAS ENGINE.

GAS POWER.—A Source of Revenue to Gas Companies ready to engage in Electric Lighting, building of Water Works, Electric Street Railways, etc.

Coal for producing Gas is less in amount than that for producing Steam, both being measured on an equal amount of work performed. And, further, with Gas,

50 to 90 per Cent. of Value of Coal is Returned

by sale of Coke and Tar, according to the market value of these products.

Labor for handling fuel is reduced, by its becoming centralized and confined to the gas house, and frequently has not increased after the addition of a power station.

With Gas Power, cost of fuel is strictly limited to the time of use.

MANY VALUABLE
AND RECENT
IMPROVEMENTS.

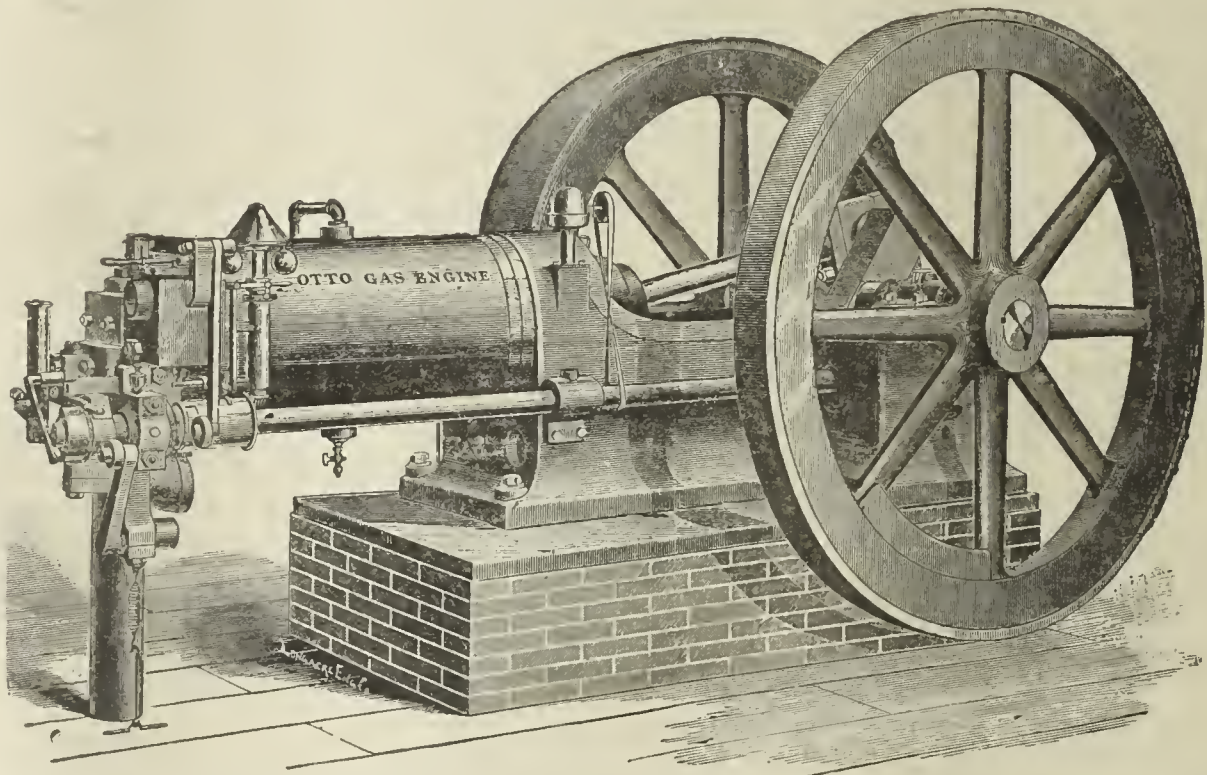

SIZES,
1-3 to 100
HORSE POWER.

Wherever Gas Companies tried Gas Power with Steam Power together in one Station, the use of Steam was subsequently abandoned or restricted, and Gas Power made to take its place.

Where Gas Companies adopt Gas Power for Electric Plants, Water Works, Sewerage, etc., they not only choose the most economical power for their use, but secure to themselves the numerous advantages of increased production, without increase of expense, and benefit thereby their entire manufacture. They induce consumers, by their example, to abandon Steam for Gas Power, and, by establishing special rates, make

Gas Power the Leading Power of To-Day,
AND SOLVE AT ONCE THE QUESTION OF FUEL GAS.

“Otto Gas Engine Works,”

SCHLEICHER, SCHUMM & CO.,

151 Monroe St. (Kent Building), Chicago.

33d & Walnut Sts., Phila.

NEW YORK AGENCY, 18 VESEY STREET.

THE AMERICAN

GAS LIGHT JOURNAL

REDMAN, KENNY, N.Y.

PUBLISHING OFFICE No. 42 PINE STREET

DEVOTED TO THE INTERESTS OF ILLUMINATION, VENTILATION, WATER SUPPLY AND DISTRIBUTION, & GENERAL SCIENCE.

VOLUME LII.—No. 15
Whole No. 775.

NEW YORK, MONDAY, APRIL 14, 1890.

{ \$3 PER ANNUM,
IN ADVANCE.

A. M. CALLENDER & CO., Proprietors. C. E. SANDERSON, Manager.
JOS. R. THOMAS, C.E., Editor. T. J. CUNNINGHAM, Asst. Editor.

ENTERED AT THE POST OFFICE AT NEW YORK, N. Y.
AS SECOND CLASS MATTER.

CONTENTS.

An Asterisk (*) denotes an illustrated article.

OFFICIAL NOTICE—

Western Gas Association..... 513

EDITORIALS—

Briefly Told..... 513

Obituary Note: Walter Burchard Houston—The Bids for Public Lighting, New York City—A Model Circular—Notes.

The Market for Gas Securities..... 514

Sixth Annual Meeting, Ohio Gas Light Association.—Official Report—Revised by the Secretary—Continued from page 484..... 515

Second Day, Morning Session: Another Year with Fuel Gas, by C. H. Evans—Discussion—Report of Committee on Location—Introducing the New Members. Second Day, Afternoon Session: Question-Box.

Public Street Lighting in New York, by E. G. Love, Ph.D..... 521

*Thwaite's Gas Fired Boiler..... 523

ITEMS OF INTEREST FROM VARIOUS LOCALITIES..... 523

Cheaper Gas for Hoosick Falls, N. Y.—Annual Meeting Royal Electric Company, Montreal, Canada—New Holder for the Cincinnati Company—A Damage Suit—Extending the Pintsch System—Gas Company for Manchester, Va.—Cheaper Gas for Paterson, N. J.—An Addition to the Kansas City Plant—Public Lighting, Wilkes-Barre, Pa.—Big Figures—The Consolidation at Indianapolis, Ind.—The Cost of it at Bangor, Me.—Corporation Counsel Darrow's Opinion—Death of Mr. Thos. Earle—The New Plant for Chicago's Suburbs—Personal—Annual Meeting, Newburgh, N. Y.—The Berlin (Conn.) Iron and Bridge Company—Mr. G. W. Farnham Succeeds the Late Mr. Cushing—More about Wilkes-Barre's Public Lighting—Annual Meeting, Montreal, Canada—Hints from Marlboro, Mass.—General Hickenlooper Captures the Electric Companies—Public Lighting, Stockton, Cal.—Cheaper Gas for Bristol, Pa.—And Many Other Items.

[OFFICIAL NOTICE.]

Western Gas Association.

SECRETARY'S OFFICE, WESTERN GAS ASSOCIATION, {
QUINCY, ILLS., April 9, 1890. }

The Thirteenth Annual Meeting of the Western Gas Association will be held at St. Louis, Mo., on the 21st, 22d and 23d days of May. The Lindell Hotel will be used as our headquarters on this occasion.

The usual reduction in transportation rates has been secured and the necessary certificates for obtaining the same will be mailed to our members on or about the 10th of May.

On the 15th of February the Special Committee on the Assignment of Papers assembled at St. Louis for the purpose of choosing subjects and assigning authors for the same. It is a pleasure to state that the responses to the requests of this committee have, in almost every instance, been favorable. The Association can, therefore, rely upon the fact that the paper contributions to the Thirteenth Annual will be of a high order of merit. The list will be announced in these columns later on.

Although "The Western" contains on its lengthy membership list the names of a large number of executive officers of the gas companies that are embraced within its territory, the fact still exists—and it is a painful one—that there still remain a considerable proportion of our Western and Southern companies who have not yet sent delegates to our annual reunions. It is the intention of the Secretary to send a circular, calling attention to the great good accomplished by Gas Associations generally, to the President of each and every company that still remains unrepresented on our roll book, accompanied with a request that he shall send his Superintendent to our St. Louis meeting. These circulars will be issued at an early day, and will be mailed to every gas

company President from the Alleghenies to the Rockies, and from the Great Lakes to the Gulf. If any of our members, or those who are contemplating becoming members, can lend a helping hand in this movement, they will confer a favor upon the Secretary. Application blanks and copies of our by-laws will be mailed to those who desire them.

A. W. LITTLETON, Sec'y.

BRIEFLY TOLD.

OBITUARY NOTE—WALTER BURCHARD HOUSTON.—The American Association is again called on to sorrow over another vacancy in its ranks in the decease of Mr. Walter Burchard Houston, who died at his home in Rahway, N. J., on the 3d inst., after a long and painful siege of illness. Deceased, who was in his 26th year, became identified with the Rahway Gas Company, and so well did he serve his apprenticeship therein that the proprietors, appreciating his worth, finally named him to fill the triple place of Secretary, Treasurer, and Superintendent. He accepted these duties at a time when the fortunes of the Company were at a very low ebb; but imbued with the idea that hard work and liberal management would restore the property to its original position, he applied both restoratives with unflagging zeal. As is not infrequently seen, when his efforts had been crowned with success, even to the point of putting the Company on a dividend paying basis, he was not permitted to enjoy the full fruit of his labors; for about the close of the spring of 1888 he was seized with hemorrhage of the lungs which eventuated in chronic phthisis. In the hope of alleviating, if not conquering the symptoms of his disease, he journeyed to Arizona, but failed of the hoped-for relief. He returned home last fall, to linger until the summons should come, and death's messenger was never received with greater resignation. In fact, from personal knowledge of the circumstances, we cannot refrain from expressing our admiration respecting the placid, uncomplaining manner with which deceased bore the ills that afflicted him. He was elected to membership in the American Association at the meeting held in New York city, in October, 1887, and was much interested in its welfare. His illness, beginning as it did shortly after his election to the Association, alone prevented him from becoming prominent in its affairs. He was a progressive engineer, a close student and a thoroughly cultured gentleman.

THE BIDS FOR PUBLIC LIGHTING, NEW YORK CITY.—Early last week the Gas Commission met for the purpose of opening tenders that had been received from the various gas and electric lighting companies in response to the city's invitation for bids for lighting the streets for 1 year, from May 1st. The figures submitted are as follows:

Name of Bidder.	Price per Light.
Consolidated Gas Company.....	\$17.50
Mutual ".....	17.50
Equitable ".....	12 00
Central " (suburban).....	28 00
Northern " ".....	27 00
Yonkers " ".....	27 00
United States Company (arcs)....	39-42 cts.
Brush " ".....	39-42 "
Mount Morris " ".....	39-42 "
Harlem " ".....	39-50 "
East River " ".....	42 ½ "

The electric bids of course are on the basis of a charge per night, and the schedule for both classes is on the plan of 4,000 burning hours per annum. The Equitable's bid is for all lamps on its existing lines of pipe, and is a compulsory figure, inasmuch as its charter names that as the maximum rate that it may exact. Given in the order as they stand in the table, the electric companies bid on the following number of arcs: 314, 337, 175, 185 and 226. Much curiosity was awakened as to what advance the electric companies would make over the figures submitted by them in the preceding competition, and their propositions of a week ago may be averaged at a 20 per cent. increase. The alleged reason for the advance is the cost of subway rentals; but this cannot be accepted as the *only* one. The simple matter of profit and loss, in the instance of manufacture and distribution, beyond doubt shares with the subway rental in a fair attempt to account for the higher figures demanded. As the matter at present stands, it seems that the usual awards will be made to the gas companies, whereas the electric lighting apportionments cannot be made on the basis of the bid figures. In other words, owing to the increased rates demanded by the electric companies, the cost of their portion of the work will largely exceed the appropriation fund allotted by the city to carrying it on. The bids were referred to Secretary McCormick for tabulation and report.

A MODEL CIRCULAR.—Elsewhere we note that a concession had been made by the operators of the gas supply at Paterson, N. J., to their consumers, and since that item was written we have received a copy of the circular issued in making the concession known to the residents. As it seems to us to be a model circular, we herewith give its salient points in the belief that it may be of assistance to others when the time comes for them to take similar action.

“OFFICE OF UNITED GAS IMPROVEMENT CO., }
146 ELLISON ST., April 1, 1890. }

“We have amended our discount schedule so as to lower the net prices on monthly bills of from 5,000 to 50,000 cubic feet. Gross price being \$2 per 1,000 cubic feet, discounts are now allowed as follows, provided that bills are paid on or before the 10th of each month:

Monthly Consumption.	Discount.	Net Price.
5,000 cu. ft.	12½ per cent.	\$1.75
5,000 to 10,000	17½ “	1.65
10,000 to 20,000	20 “	1.60
20,000 to 50,000	25 “	1.50

“We thank the public for past patronage, and assure them of our desire to continue to serve them well and faithfully. In continuance of past and present policy (not as a new departure), we place as the four cardinal points of our business compass—1, good service; 2, square dealing; 3, courteous attention; 4, prompt response to complaints; and hope to merit and obtain increased business. Using the best methods and materials known to modern gas making, we cannot but feel that we are furnishing a superior article. If there should be any cases of dissatisfaction, the causes will be found to be local, usually in the house-pipes or burners, and we would desire to be informed of any such cases and to have a chance to propose the proper remedies. We intend in the near future to have a house-to-house inspection of burner tips, etc., and trust to have the co-operation of each consumer. In this our object will be, not to increase the size of the gas bills, but rather to increase the illumination. In endeavoring to produce the best light and the most light for the least money, consumers' interests and our own are mutual. We have provided blanks to be given to managers of mills, factories, public halls or other large consumers, who may wish to have a record of each day's consumption of gas. We advise consumers to frequently read their meters, and are always glad to explain the method, or to give other necessary explanation or information. Gas stoves are now in use by hundreds of families in our city, both for cooking and heating. The convenience attending their use, and the saving of time, labor, and trouble, are now too well known to need more than mention. When properly used, the cost is no more (sometimes less) than that of coal. We handle stoves at cost, and would prefer to sell them, making, if desired, very easy terms of payment. We also have stoves to rent at low monthly rates. We have other convenient arrangements, such as self-lighting burners; nursery burners, for quickly heating over an ordinary gas flame small quantities of water or other liquids; curling iron heaters; iron heaters for family use, for tailors, laundries, etc.; waffle and cake bakers, etc., etc.—UNITED GAS IMPROVEMENT COMPANY.”

NOTES.—Professor Chas. L. Robbe, of Trinity College, has been appointed Official Gas Examiner for Hartford, Conn. We congratulate the authorities and the Gas Company on his selection: for his past record is the best guarantee of his fitness, capacity and impartiality.—The proprietors of the Hartford (Conn.) City Gas Company have de-

termined to install an auxiliary water gas plant. In all probability the contract for same will be awarded to the United Gas Improvement Company, with instructions to erect a double set of the improved type of Lowe apparatus, each set to have a per diem capacity of 250,000 cubic feet.—Mr. Chris. Felt, a brother of Mr. Henry Felt, Supt. of Distribution to the Cincinnati Gas Light and Coke Company, has been appointed Superintendent of the Addyston Pipe and Steel Company's works.—The streets of Tyrone, Pa., have for the last three years been lighted by means of 25-candle power incandescent electric lamps, the contractors maintaining 100 of the same on the basis of a charge of \$1.33 per lamp per month, moonlight schedule. The number of lamps in use was 100. As the contract expires on May 1st, the authorities asked for tenders for another 3-year agreement with the following result—the bids were opened on April 7th. Tyrone Electric Light Company, 25-candle power lamps (100 in number), moonlight table, \$1.50 per month each; all night and every night, \$2; Jones & Underhill (Columbus, Ohio) for naphtha lamps, \$19 per lamp per annum; the Tyrone Gas and Water Company did not tender. In view of the increased rate demanded for electric light, Council deferred action in the matter of an award.—During the year Director Wagner reports that 5,241 new meters, and 10,076 new services, were placed through the Philadelphia Gas Bureau last year in that city; that the number of additional burners placed footed up at 113,474; and that the total number of gas consumers is 128,867.—Mr. J. W. R. Cline, whose promotion has been fairly won through a 15-year term of apprenticeship, so to speak, in the service of the Company, has been appointed Superintendent of the Springfield (O.) Gas Light and Coke Company, vice Nathan Kinsman, resigned. Mr. Kinsman, who has served the Company most acceptably for something like 35 years, retires on account of ill-health and advancing years. The fraternity will unite with us in the hope that rest and travel will speedily restore Mr. Kinsman to his old-time physical condition. Mr. Cline has acted as Assistant Superintendent of the works for some years.—Mr. George W. Harper has resigned from the Superintendency of the Fall River (Mass.) gas works, in order to accept a more responsible position in the same line of business at Kansas City, Mo.—Mr. R. B. Taber, as Clerk of the New Bedford (Mass.) Gas Light Company, gives notice that a special meeting of the stockholders is called for Wednesday next, to decide (1) whether the Company shall purchase the rights, privileges, etc., of the New Bedford Edison Electric Illuminating Company; (2) to authorize an increase of the capital stock; (3) to amend the by-laws so as to provide for increasing the Directorate to 11 members.—Messrs. John W. Wright, Thos. C. Young, John S. Latta, Jas. L. Armstrong, John E. Wright and Wm. J. Latta, have applied for a charter for a Company to be known as the Parkersburg Gas Company, “the character and object of which is to manufacture and supply gas for light only to the public at the Borough of Parkersburg, Chester county, Pa.”—The Brooklyn (N. Y.) Gas Company will construct an additional holder.—The Charlton suit against the Gas Trust has been withdrawn, and a sum of money equal to 1 per cent. on the common stock has been “disbursed” by the Trust's Treasurer.—Mr. W. C. Whyte, of New York, will build the tank for the new holder to be constructed by the Peoria (Ills.) Gas Light Company.

The Market for Gas Securities.

The city market for gas shares shows no change from the time of last writing, although investment inquiry was rather more on the brisk order than has ruled for some time back. To-day's (Friday) opening sales were effected at 96½ for Consolidated, and Equitable was sought for in a quiet way. Mutual, too, fully holds its own. In fact, it is undeniable that city gas shares are now attracting more attention from “safe” investors than has been the case for some time back. We hold to our prediction of a month ago that Consolidated will cross the par line before the summer is over. In Brooklyn shares no change of moment has occurred, and the situation there seems to be all in favor of the holders. The Edison Branch Company in Brooklyn may be written down as a very weak competitor of the gas companies—all large users of the incandescent light supplied from the Pearl street station are dissatisfied with the lighting service and its cost. The usual quarterly dividend of the Newark (N. J.) Company (2½ per cent.) has been declared, as also has the Citizens' (same city) allotment of 2 per cent. Chicago Gas Trust stock is in demand to-day at 45¼ to 45½, and the holders thereof have received a sum equivalent to 1 per cent for the last quarter, and are now engaged in an attempt at solving the riddle propounded in connection therewith by the Trust's Treasurer, who says that the aforesaid 1 per cent. is not in the nature of a dividend, but is a “disbursement.” Permitting it to go at that, we may remark that the meeting on the 24th inst. will undoubtedly witness a reorganization of the Trust that will bother even a Chicago lawyer to find a flaw in.

[OFFICIAL REPORT.—REVISED BY THE SECRETARY—CONTINUED FROM PAGE 484.]

SIXTH ANNUAL MEETING, OHIO GAS LIGHT ASSOCIATION.

HELD AT THE BOODY HOUSE, TOLEDO, OHIO, MARCH 19 AND 20, 1890.

SECOND DAY—MARCH 20—MORNING SESSION.

Mr. C. H. Evans, of Jackson, Mich., now read his paper on—
ANOTHER YEAR WITH FUEL GAS.

Mr. President and Gentlemen:—One year ago it was my privilege to present to this Association a paper on "Fuel Gas," and to-day I am called upon by our worthy Secretary to renew this subject.

Many of you, no doubt, have heard at the various Association meetings, or read in our gas journals, a great many papers and articles on this subject during the past year. Some of them have been of an encouraging nature, while others, and I might say the most of them, have been decidedly the other extreme; but if you stop to consider a moment you will remember that the words, "assume," "if," and "theoretically," occur at frequent intervals. No doubt the writers have given the subject much careful thought and study; but who among you can tell by theorizing what will occur in practice?

I could monopolize your time for hours on the theoretical possibilities of fuel gas, but that does not satisfy. Facts are what we want—facts demonstrated by actual results—and until such facts can be presented beyond all possibility of doubt, few gas managers would care to venture, in a business way, into the unknown—few would care to run the risk of success or failure, judging of the conditions from a theoretical standpoint.

There is no longer any necessity to theorize; there is no longer any reason to doubt; for 70 miles from this very city there is a fuel gas plant in operation, doing a business that ought to convince the most skeptical. A plant that is not of the mushroom order, but is built to stay, and is second to none of its size in the country in mechanical appliances for reducing labor to the minimum.

It may not be uninteresting at this point to describe what I am pleased to term our model purifying house. It is a brick building, approximately 40 ft. wide, 115 ft. long, and 30 ft. high to under side of roof trusses. Our boxes, 4 in number, are 20 ft. by 20 ft. by 4 ft. deep, and hold 1,000 bushels of purifying material, each. They are supported on iron girders 12 ft. above the cemented basement, which leaves this latter space entirely free from columns and gives ample room for re-vivification of purifying material. As the lower floor is level with the street, it is easy of access, and the numerous windows afford ample light with plenty of opportunity for rapid circulation of air. The covers are lifted and moved by hydraulic machinery, and the purifying material is handled almost entirely by a system of conveyors, which I will describe. There is a line of conveyors running over the purifiers, which are provided with two discharge openings, operated by slide valves over each box, and another line is suspended under the bottom of the boxes that has two openings, directly under the two discharge pipes in the bottom of each box—this line also has slides in the bottom at frequent intervals. A third line is placed in the center of the lower, cemented floor, the top being flush with its surface, and runs the entire length of the building, having slides or openings at desirable points. An elevator (similar to those used to handle grain), a steam drum and shovel, complete the list of machinery necessary for one man to do the work of six or seven. The *modus operandi* is simple. One man steps into the field, whenever it is necessary to clear a box, at, say, 7 o'clock in the morning, and starts the machinery. The cover is lifted by hydraulic device, the man steps into the box and lifts out the trays that are over the discharge openings. As these trays have rods attached to them that protrude above the material, the lifting out is easily accomplished. The material is shoveled through discharge pipes to conveyor below, which carries and deposits it at any point desired by simply opening the slides; the emptying is done in short order, and the man, after opening the two discharge valves over the boxes, descends below, hooks on his steam shovel to rope attached to drum, and drags the material required for filling to the center conveyor. It is carried along by the latter to an elevator at the end of the building, which receives it, elevating it to the floor above, depositing it in the conveyors over the boxes. This line conveys it to and deposits it in the proper box, and there is nothing left to do but level it off, and this is easily accomplished by 6 o'clock, with the labor of one man. The freshly deposited material below is leveled by a steam shovel and turned at proper intervals by a steam plow.

Our system of handling coal is somewhat similar to the above. The coal, which comes in on a side track, is shoveled direct into a hopper, connected to an underground line of conveyors, which carries the coal to our shed, where it is elevated and deposited at any desirable point. The same line of conveyors brings the coal to our generator house, where it is elevated and delivered into a scale hopper, which not only automatically weighs the coal, but rings a bell in the coal shed whenever the desired amount is in the hopper. The coal truck is wheeled under the hopper and filled by opening a slide.

It is somewhat alarming to contemplate the erection of a fuel gas plant, looking at it from the standpoint taken by Mr. John Young, in his recent paper read before the American Association; but as his estimates are taken and his conclusions drawn from his experience in the sale and delivery of natural gas, I am not surprised at the figures. In fact, I can easily credit the statements since I made a personal investigation of the appliances in use at Allegheny. No attempts had been made, that I could ascertain, to use the gas economically. The coal stoves and furnaces filled with broken brick, and the gas attached thereto, were in universal use. Under such conditions is it to be wondered at that such vast volumes of gas are required and such fluctuations in demand should exist? As an illustration of the differences that proper appliances make in the consumption of gas, I will give you the figures of gas consumed by two houses—one fitted up with a gas furnace, and the other with the gas attached to an ordinary coal furnace filled with brick. The former is a 14-room house, and was warmed throughout during the winter months with an average consumption of 39,000 cu. ft. per month. The latter was a 10-room house, and required a consumption of 125,000 cu. ft. per month.

In the manufacture and sale of illuminating gas the whole distribution occurs in practically 4 hours of each day, and necessitates a storage capacity at least equal to the output, or a manufacturing capacity equal to three times the output, if the storage be reduced one-half. The mains also have to be of sufficient size to supply the entire daily output in practically 4 hours.

Is it not plain to be seen that certain mains supplying a given quantity of illuminating gas would, if used to supply fuel gas, where they are in use 18 hours each day, distribute $4\frac{1}{2}$ times as much as the latter? Is it not consistent to claim a decrease in holder capacity in the same ratio? There is equally as wide a difference in the winter and summer output of illuminating gas as could possibly exist in the supply of fuel gas. Mr. Young must certainly have had some standard of comparison in mind when he said that the storage capacity of a fuel gas plant would have to be simply enormous; but he certainly could not have used the supply of illuminating gas as a comparison to draw his conclusions from. My daily record shows no such erratic demand as Mr. Young assumes must exist. He is generous enough to credit the possibility of getting 30,000 cu. ft. of fuel gas from a ton of bituminous coal, while the facts are, we are getting 40,000 cu. ft., and have every reason to expect 50,000 from improvements now in process of construction.

What constitutes the success of any business, if it is not the selling of its goods? The fact that people buy shows that there are certain merits in our gas, else why should they continue to use it? Why should our business continue to grow and our receipts to increase if the supply of fuel gas is not a success? Is it necessary the gas should be in every house in Jackson before it is entitled to the claim of success. Such seems to be the impression of some gas engineers.

I had occasion a short time ago to read a number of letters from different gas managers, which were in answer to inquiries of a certain party who proposed to introduce fuel gas into the city where he resided. I was painfully surprised to learn the opinions of some of the success of our Jackson plant. Especially so in this case, because I am positive that the engineers in question never were in Jackson to investigate the system in use, but were only too willing to cry down something they knew nothing about.

There seems to be a popular fallacy existing among a great many gas engineers that illuminating gas has $2\frac{1}{2}$ times the practical calorific value of fuel water gas. This is probably due to the assumption that the heat of combustion of a composition of gases is the same as that of its elements. The fact is usually the reverse. Thus, marsh gas, C H_4 , which forms more than one third of the bulk of coal gas, is composed of three parts (by weight) of carbon and one part by weight of hydrogen. In one pound of marsh gas the heat of combustion of its elements, when burned separately, is, for carbon, 10,914 units, and for hydrogen 15,381, making a total of 26,295 units as the combined heat which one pound of marsh gas ought to yield. But by actual experiments the heat evolved is only 23,616 units; hence marsh gas in burning evolves 2,672 units per pound less than its elements, or a loss of about 12 per cent.

Another serious drawback to the practical utilization of the heat in the combustion of illuminating gas, is due to the admixture of such vast volumes of nitrogen which of necessity must be taken in to obtain the proper amount of oxygen. This nitrogen not only absorbs the heat and detracts largely from the flame temperature of the gas; but by its insidious presence it casts off into the atmosphere unconsumed gases the moment a cold vessel is placed in contact with the flame. In fact, I can safely assert that the air dilution necessary for the complete combustion of illuminating gas, detracts from its theoretical value fully 50 per cent. This would not appear to be the case if the specific heat of the nitrogen which enters into the composition was subtracted from the theoretical heat evolved. But this is simply another illustration of the difference between theory and practice. As fuel water gas requires but 2.47 cu. ft. of air for the perfect combustion of a cu. ft., it is slightly affected, comparatively speaking, by the air dilution.

Many tests have demonstrated the fact that illuminating gas, as used for cooking and heating, is worth but 30 per cent. more than fuel water gas, instead of $2\frac{1}{2}$ times as much.

Let us review the oft-trodden ground and see if there is not some reasonable possibility of making the general sale of fuel gas a success. There are certainly elements of advantage in its use that ought to make it preferable even at a higher cost than a solid carbonaceous fuel.

First.—The cost, labor and inconvenience of handling a heavy material is avoided, the fuel being capable of easy distribution.

Second.—It is in a form also free from those material impurities which involve a large residual waste, besides impairing combustion.

Third.—It is also free (if it be a purely combustible gas) from those ingredients which, in the present methods of heating, involve even larger loss than the cause last mentioned.

Fourth.—It is in precisely the condition to unite perfectly and instantaneously with the oxygen of the air, thus securing a thorough combustion. Hence it gives an immediate and uniform result, and its flame temperature is constant.

Fifth.—The intense and steady heat of the flame just mentioned saves both time and money, by presenting an even fire surface ready at the moment of ignition.

Sixth.—It is a fire capable of concentration upon the precise point where the result is desired, and one that is thoroughly under control—the turning of a valve starting, graduating or stopping the combustion at will.

Seventh.—The general cleanliness of the system, no dirt or residuals being left.

Eighth.—The decided advantage from a sanitary standpoint of simply burning combustible gases in our dwellings, instead of attempting to make them as well, by means of the imperfect gas machines called stoves. In the one case, the only risk arises from the possibility of a leak, readily detected by the sense, and having simply mechanical remedies; in the other it is a much more serious risk, because the defect is a chemical one, consequent upon imperfect combustion, and the infusion of poison into the atmosphere is likely to be frequent and insidious, to say nothing of the deoxidization of the air by contact with red-hot iron surfaces.

These facts appear to be overwhelming arguments in favor of a gaseous fuel as against a gross form, and it is a matter of some considerable surprise to me that every family on our lines of main is not a consumer. But there is one class of people that always wait to see what their neighbor is going to do, and another class that is afraid of everything new. But, nevertheless, there are between eight and nine hundred families consuming our gas, and $\frac{2}{10}$ of all the business places in the city are lighted by our method of illumination. To this last feature I want to draw your special attention, for I do not believe a fuel gas business can be perfect and complete without an incandescent burner. The one we have in use at Jackson (the Fahnehjelm) has during the past year made such rapid strides towards perfection, that, to one who remembers it when first brought before the public, the change seems marvelous. The comb has now double the life it had a year ago, and emits a beautiful, straw-colored light, that is very attractive to the public, as the fate of the now defunct Jackson Gas Light Company will testify.

A series of photometrical observations, which I have made from time to time with the Fahnehjelm burner since its improvement, shows an average of 5-candle power per cubic foot of gas burned for the first 150 hours burning, and a gradual diminution until, at the expiration of 250 hours, it has decreased to a shade less than 3 candles per cubic foot of gas consumed.

I removed 4 burners from a chandelier in my house that had been in use for 38 days, in the months of December and January, and had been burned at least 190 hours. A photometrical observation of the burners

showed an illumination equal to 3.9 candles per cubic foot of gas burned.

One burner which costs the consumer 4 cents practically represents the oil that is used to carburet a thousand feet of water gas, as well as the additional amount of fuel expended in bringing to proper temperature the surface used to gasify the oil. In many places, the cost of carburation of oil reaches from 25 cents to 30 cents per 1,000, and in no instance has the cost reached so low a figure as is represented by our Fahnehjelm burner.

That fuel gas has established itself in the field to stay, I do not believe there is any longer need to doubt.

Discussion.

The President—You have listened to the paper of Mr. Evans, which I doubt not has been a source of satisfaction and instruction to those present, and I trust that the discussion shall bring out as much of value as the reading of the paper has.

Mr. Cantine—I believe all the courts of this country have decided that however credible a witness may be it will do him no harm to be corroborated. I was in Mr. Evans' works at Jackson, Michigan, at a time when he was not present. However, his Superintendent treated me very courteously. I believe his purification plant and apparatus are really better than he said. His description hardly makes the plant out as good as it really is. The coal benches were of about the usual type—having 3 benches and 12 cupolas on the same floor. The hot coke was drawn out from the retorts and was blasted up and made fuel gas by the use of steam. One question that puzzled me a little (perhaps Mr. Evans will kindly enlighten us) was that they made an excellent quality of coal gas, but the Superintendent didn't tell me what they did with it. I asked the question, and, I think, I got no answer.

Mr. Evans—I will say in answer that we have about 7 miles of mains that do not parallel our water gas mains, and we have on the former between 500 and 600 consumers of coal gas. The amount of gas necessary for these consumers is separated in the process of manufacture and delivered to them through the old Company's mains. The balance of the gas is sent back and into water gas. We have three generators in use.

Mr. Cantine—I understood the Superintendent to say that your price was 30 and 40 cents, according to the quantity used. Am I right?

Mr. Evans—Yes, sir.

Mr. Printz—I would like to ask Mr. Evans if they have shut down the coal gas works entirely?

Mr. Evans—Yes, sir; we have not only shut it down but taken it apart and sold it.

Mr. Printz—Then, again, I wanted to ask you what was the price of solid fuel—that is, of soft and hard coal—in your city?

Mr. Evans—The coal mined in Jackson carries considerable sulphur, hence very little of it is used for fuel purposes, except in the rooms. The bituminous coal used is brought from the Ohio region, and costs at retail to the consumer about \$4.50 to \$5 per ton. Anthracite coal in the summer season can be bought for \$6 or \$6.50 at the outside per ton.

Mr. Printz—I would like to ask whether you buy pea, nut or lump coal, and whether it is Youghioghney or native coal that you are using in your fuel plant. And another question as to the comparative cost between heating a house with your gas and with heating that same house with solid fuel?

Mr. Evans—We are now using Youghioghney nut. The cost of heating a house with gas, as compared with solid fuel, varies considerably—you would be surprised how much. In some instances it costs from 25 to 30 per cent. more, while in other instances it is just the reverse. It depends a great deal on the consumer. If they use the gas wastefully—that is, leave it on at times when they don't require it—it is likely to be more expensive than the solid fuel; but with the steady heat coming from the gas stove or gas furnace your house becomes thoroughly warmed, and not only thoroughly warmed but warmed uniformly through the whole of the 24 hours. There is no variation. In the use of hard coal the temperature goes down—it is only when it gets down to the point where you can notice it that someone is sent down to look after the furnace—then cold fuel is put on the fire and it is at least half an hour before you feel the effect. There is an interval of time when you have not been heating your room up to the proper degree of temperature. All these things have to be considered, of course.

Mr. Hyde—What appliances for heating houses do you use in Jackson—what kind of furnaces?

Mr. Evans—One made especially for it, or a furnace made especially for the gas, so that the products of combustion will go out of the chimney at the very lowest possible degree of temperature.

Mr. Hyde—What does it probably cost to heat the lower part of a house of 4 good-sized rooms?

Mr. Evans—Representing how many cubic feet of space?

Mr. Hyde—The rooms probably 16 feet square—or four rooms 14 by 16 each.

Mr. Evans—Say, 2,000 cubic ft. space—8,000 feet altogether. About \$32.

Mr. Hyde—For how long a time?

Mr. Evans—In the winter season—the heating season—I have made a great many experiments in that direction, and find that the safest figure I can reach is about \$4 per 1,000 cubic feet of space, heated under the general conditions.

Mr. Printz—Mr. Evans, does the Fahnehjelm comb hold its own with incandescent electric light as well as illuminating gas of 18 or 20-candle power?

Mr. Evans—I think I can safely say it does. I think the secret of illumination by incandescent electric light is the fact of the distribution of that light. It is hung around in different parts of the room and distributed thoroughly. The light from a chandelier emanates from one point, and the walls of a room, and every place where you look for the effect don't seem to have the light cast equally; at the chandelier there is an excess of light. I don't think any business places in the country are lighted as well as those lighted with the Fahnehjelm burner. I think it is due to the fact that the light is cheap that they want more of it. When the bills come in they are so reasonable that they feel they can afford more illumination.

Mr. Dittmar—Will Mr. Evans have objection to giving us the actual cost, delivered through the meter, of the gas at Jackson? Another question, while I am up, is whether he has had experience enough to give us the actual cost of a cook stove for one month—say, for a four-hole top—for a family of half-a-dozen? We people that are in the natural gas region would like to compare prices with those that are using the artificial fuel gas.

Mr. Evans—In answer to the first question, the cost of delivering to the meter is a very uncertain figure in the delivery of any gas—that the cost of the gas in the holder is quite uniform, but the cost of delivery is very irregular, which of course is due largely to the office expenses and the salaries of the officers of the company. In some cases they are paid three times as much as they are in other cases, and the office expenses consequently exceed in the same proportion. The cost of gas for a month, for a family of six, cooking on a four-hole stove, I should estimate to be about \$1.30, if used economically. In fact, the cook stoves that are in use show a consumption that varies from 16 cents a month to \$5. In the latter instance, it is due to the fact that the party who uses the stove cooks for 18 men—boarders, laborers—and the stove does all of the cooking—meats, bread, in fact everything.

Mr. Dittmar—Is that the ordinary cook stove—the old cook stove converted into a gas stove?

Mr. Evans—A cook stove made especially to burn gas.

Mr. Dittmar—Do you find any difference in the cost of the fuel where the old coal stove is converted into a gas stove and where they use a stove especially made for gas?

Mr. Evans—Yes, a decided difference; I should estimate it would cost three times as much at least.

Mr. Printz—I can readily see that the statement Mr. Evans makes is true in regard to the diffusion of the electric light. Latterly I have noticed that electric light people, in placing the incandescent burners, place them around the top of the room, near the ceiling, about 8 feet apart, so that their lights are divided and reach where you would like to see. Mr. Evans says that the gas is concentrated at the chandelier. A question I would like to ask Mr. Evans is as to the price charged for the illuminating gas and that charged for his fuel gas; and whether there is any difference made between the consumers who have only the illuminating gas and those that have both—whether you discriminate?

Mr. Evans—No; we make no discrimination at all in the prices of the illuminating coal gas. It is sold at \$1.35, net, and we aim to make a very good quality. We don't want it said that we reduce the quality of illuminating gas in order that the Fahnehjelm burner may be introduced in its place. We supply a 19-candle gas, which is about as high as you want to send out coal gas. We often carburet it by the use of a little oil, in order to bring it up to the right standard. Those who consume 5,000 feet of water gas a month get their gas at 40 cents a thousand, with a rebate of 10 cents a thousand if paid on or before the 10th. If less than 5,000, it is billed to them at 50 cents per thousand, with a rebate of 10 cents. I might state, as a comparison between the lights, that the incandescent electric light company had about 1,000 burners there a year ago. They now have 800 in, and I think in a short time they will have about 600, as there are about that many changing now.

The incandescent electric light is sold there now for about what they can get. In some places I know they are paying but 20 cents a month per lamp.

Mr. Printz—Is that the Edison incandescent?

Mr. Evans—Yes, sir.

Mr. Printz—Yesterday afternoon, during the course of a conversation with Mr. Evans, he made some statements and gave me some figures, and for the benefit of the discussion I would like him to make the same statement—that is, in regard to the yield of coal per pound that you get in these retorts, and the yield you get from the coke in your generator.

Mr. Evans—We are using in our benches Lima crude oil, and are aiming to keep a very uniform heat. We are able to keep any temperature we desire. We also use it under our boilers. We are now running our retorts on about 3½-hour charges, on 1,800 pounds. We obtain from every pound of coke that enters the generator at least 20 feet of gas; a great many days it runs up to even 30, but when I say 20 I take the average—not for a week nor for a month, but for two months or three months, because those who manufacture water gas know how that varies each day. From the bituminous coal in the retorts we can and do realize over 5 feet. The balance of the illuminating gas that we do not require to supply those that use illuminating gas is drawn back by the exhauster and forced through the generator tubes and sent out in the form of hydrogen into the water gas. The marsh gas is thus converted into hydrogen, and for the actual number of feet of illuminating gas that enters our generator we receive 30 per cent. more in the form of fuel gas.

The President—One feature alluded to in Mr. Evans' paper I may not have got exactly right. I only listened to it as it was read, without any further knowledge of it. The vital question with most of us, I think, in this connection is whether we have or are tending toward the realization of a perfect fuel gas system, and whether the conditions are met in the experience at Jackson thus far with reasonable certainty. The point is made that Mr. Young's experience with natural gas, and his comparison with illuminating gas, hardly represents the conditions. It has occurred to me that possibly Mr. Evans' experience has not been so very extended until the past winter.

Mr. Evans—I have had experience in the distribution of fuel and water gas for the last seven years. In fact, water gas was introduced into Lynn, as I said before this Association a year ago; but under the conditions I detailed then it could not be a success. However, from that I gained a great deal of valuable experience, which I would hardly want to go through again, I assure you. So that in starting into the fuel gas business in Jackson I had the benefit of that experience. As in everything else new, hardly a day passes that one does not learn something; and although I think we are achieving success there without doubt, we are not sitting down satisfied with what we have already obtained. In fact, we are erecting a generator there now—although we have no special use for it so far as adding to our present capacity is concerned—in which we propose to introduce bituminous coal direct. It will not only coke its coal, but will save the labor of drawing the coke from the retorts. I would be glad to give you a more clear explanation if I was at liberty to do so.

The President—The point in my own mind that I have not quite reached was with reference to the storage capacity that Mr. Young had concluded would be necessary. The winter that he had just passed through had been an exceptional one in the relation of the fuel supply to the necessities to be met, either by an amount of plant sufficiently large or capacious, with the necessary help to run it, or, on the other hand, a sufficiency of storage to supply the conditions. I think perhaps the conditions of supplying illuminating gas would not furnish exactly a criterion, but a wider range of conditions would have to be met. These features are only thoughts that occur to me, and I had hoped, perhaps, we might bring out still further light from Mr. Evans' experience. As we take the use of illuminating gas, its fluctuations depend very largely upon the variation of daylight. You know that means quite considerable. Mr. Hyde has already alluded to it, but how much greater it is when you consider the vastly larger output which will be necessary, in any event, for fuel purposes, and the fact that our temperature sometimes changes from about freezing to many degrees below zero within, I was going to say, 18 hours' time—say within 24. It seems to me here is a factor that the past winter furnished us no criterion to judge by at all.

Mr. Rood—Mr. Evans, did you ever experiment so as to get the exact comparison between your fuel gas and hard coal for heating, under similar circumstances?

Mr. Evans—Yes, sir.

Mr. Rood—For instance, take the same room and heat it to a certain temperature by your fuel gas and with coal?

Mr. Evans—I have done so.

Mr. Rood—What was the result?

Mr. Evans—It showed that 20,000 feet of the gas was equal to a ton of anthracite coal.

Mr. Rood—Was that by actual experiment?

Mr. Evans—Yes, sir; by metering the gas.

Mr. Rood—What is the price for your gas in Jackson?

Mr. Evans—The lowest rate is 30 cents a thousand.

Mr. Rood—Then your conclusion was that the cost under the same circumstances is about equal?

Mr. Evans—I think in the majority of cases it would be a trifle more, owing to the fact of their not understanding just how to manipulate their gas stoves and furnaces to get the best results. That, of course, is our greatest trial. In the use for cooking purposes gas does not cost one-quarter what coal does.

Mr. Rood—Have you had improved stoves and burners for your fuel gas during the last year and a half?

Mr. Evans—Yes, sir; I think it was about a year ago that we began to manufacture our own appliances, from our own patents, made from the result of experience.

The Secretary—I would like to ask Mr. Evans if he has tried any of the heating stoves made by the Century Gas Stove and Furnace Company.

Mr. Evans—No, sir; I have not. I have received their catalogues, and intend to make a trial of their goods; but I have not got to that point yet.

Mr. Rood—Is your present gas stove improved so that any fumes that may arise from the burning gas are carried off?

Mr. Evans—The heating stove?

Mr. Rood—Yes, sir.

Mr. Evans—In some instances the air is vitiated and saturated with carbonic acid if the room is too close; but no fumes come off from the burning gas.

Mr. Rood—Are your stoves arranged so that they are connected with the flues of the house—so that any impurities that may arise are carried off; or do they come into the room?

Mr. Evans—About half of them are connected with the chimney. That is left to the consumer. The conditions are explained thoroughly and they can do as they see fit.

Mr. Rood—Which would you recommend?

Mr. Evans—I would recommend connecting with the chimney in every instance. It does not take any more gas in any instance to heat a room when the stove is connected with the chimney than when it is not. The hydrogen in the gas is formed into moisture, saturates the air, increases its specific gravity, and requires more heat to heat that space than it would if the moisture and carbonic acid were carried off. By arranging your stove pipe with the proper sized damper you can pass the products of combustion out of that stove pipe at the temperature of the room or very nearly so.

Mr. Rood—It also acts as a ventilator in the room for ventilating the room to a small degree?

Mr. Evans—Yes, sir.

A vote of thanks was tendered Mr. Evans.

REPORT OF COMMITTEE ON LOCATION.

Mr. Printz—The committee in their conference this morning met with a very serious obstacle. There were no applications from the members to have the next meeting at their places, but several said they would like very much to have the Association meet in their cities only that the banquet feature would preclude them from asking it to do so. They made the statement that while they themselves would like very much to invite the Association to meet there and to give them a banquet, they individually did not feel able to do it, and while they were officers of their companies, they did not feel like taking the responsibility of asking the Association to meet there with the expectation of being furnished a banquet. They were afraid, in some cases, that their Directors, or the members of their company, would not sanction an invitation of that kind, and would not back them. Several, and I might say more than several, have expressed themselves to me in this matter that they were opposed to the banquet feature, and that their understanding when the Ohio Association was formed was that there was not to be anything of that kind. One or two said to me that the cost necessary to give a banquet would be as much as one per cent. on all their capital stock, and they did not feel like an expenditure of that kind. In two invitations—I could hardly say they were invitations, either—it was intimated that

the offerers were perfectly satisfied, and in fact would like to have the Association meet at their places, with the understanding that they were not to expect a banquet from their companies. If, after the place of meeting was selected, the companies which they represented saw fit to give a banquet, well and good; but they would not promise that there would be anything of that kind. Columbus has been named, so has Cleveland, and Zanesville is a third. The gentlemen representing Cleveland say they would like to have the Association meet there, but they would prefer to have a conference with their officials, and would rather have the meeting there the following year. The gentleman representing Columbus would like very much to have you go there. He has an eye open to the business interests of his city. Some others have spoken to me about Zanesville as being near the central portion of the State, a point which is very readily reached by railroads, and which all our members could get to in a very short time. They did not think we ought to go twice in succession to the northern portion of the State. They did not feel that we ought to go as far south as Cincinnati—that the Western Association had been there a very short while ago. For these reasons we have selected, and the Committee would report in favor of, either Zanesville or Columbus, with the understanding that a banquet is not promised. I can say, and Mr. Allen, who is Secretary of our Company, agrees with me, that if the Association chooses Zanesville we will agree to treat you well and see that you are entertained very well, but we will not promise a banquet. Mr. Butterworth, of Columbus, says the same thing. That is the report of the committee, Mr. President, and if the members please I would like to have them express themselves with regard to this banquet feature.

Mr. Cantine—Mr. President, what is the matter with Alliance? We have made about enough money out of our water gas plant in the last year to pay for a banquet. (Laughter.)

Mr. Printz—I am only sorry, Mr. President, that Mr. Cantine did not present his application.

Mr. Hyde—Mr. President, naturally, under the circumstances, I would not say anything about this business, because I am a new member. I am a member of the American and of the Western Associations, and have brought to myself some little notoriety in reference to this banquet business. I would not say anything now except that it has been brought out, by the report of the committee, that considerable opposition is manifested in regard to having a banquet. I want to say with reference to this (as I can now), that I have always been opposed to having any banquet, and, if we have a banquet, to having any liquors of any kind. There are some cities that can afford to provide a banquet. It is all right that they should, so far as that is concerned. They are perfectly able to, and perfectly willing; and those who go there are perfectly willing that they should furnish it and pay for it. But there are some who cannot do that. In some of the smaller towns, as the chairman of the committee has said, it would take 1 per cent. of their capital to pay for the banquet. Well, now, we ought to have a little regard for our brothers as well as ourselves. We should not engage in any methods that would compel others to do what they can't do, or what they are not able to do. The easy way to get along with that is to have none. Now we could have this evening our tea, or supper, or whatever you choose to call it, at the usual time, and adjourn to this room and have our little talk. That costs nothing. We are going to pay for our keeping here to-night anyhow, and if we have a banquet we are going to pay for that, too; and, besides that, we are going to pay for staying a day longer than we want to. There are three ways. Now if we could do it in this way—have our supper in the usual way, and have with it this entertainment, this "flow of soul," without the flow of liquor and wine, and have a good time, it would be all right. I have upon other occasions, and at other Associations, mentioned Cleveland. Mr. Lindsley and myself and a good many others belong to the Civil Engineers' Club of Cleveland. They are, like all these Associations, formed for getting good from each other and profiting by exchanging thought. When that club was started, in preparing for the first banquet that we had, the question was: "Shall we have liquor—shall we have wine at the banquet?" and a few said, with determination and positiveness, "No, not if we go." And so that has been left out, and we have had meetings now for 5, 6 or 7 years, and a better banquet or better entertainment cannot be had anywhere. Everything goes off in fine style, the entertainment is first-class, but we don't have any wine. Now I know it is not necessary (the wine question, however, is not under discussion, but I am willing to speak of that) to have wine if we have a banquet; and having in view the ability of what might be called smaller towns and cities to provide a banquet, I don't know but it would be well to say that we won't have any, and then we will all stand on the same basis; and any place, where the hotel facilities are such as to accommodate those who can

gather, is free to invite with cordiality this Association to come and see them.

Mr. Wilkiemeyer—Mr. President, I have a resolution to offer on this subject, which I will read:

“Whereas, It was the original determination of this Association, as expressed in a resolution unanimously adopted at its meeting for organization in Columbus, Ohio, September, 1884, that the feature of a banquet should not become a concomitant of its annual meetings; and,

“Whereas, The tendering of a banquet to our members and visitors in connection with our annual meeting, by local companies in the cities where meetings are held, having, contrary to the expressed determination of our charter members, gradually grown into a custom that might possibly occasion embarrassment in the future, and militate against the best interests of the Association; therefore,

“Resolved, That in the future this Association shall decline any tender of a banquet on the part of local companies in the cities in which it shall decide to hold its meetings.” [Seconded.]

The President—Gentlemen, you have heard Mr. Wilkiemeyer's resolution. Are there any remarks. This is a matter of some little importance. I think Mr. Wilkiemeyer has put it in tangible shape, and I trust it will be freely discussed.

Mr. Allen—Mr. President, as our town is one of the applicants for the next meeting, it would probably be better for me not to say any thing, but in order to do our Company justice I do want to say one thing. Our Company is not small or niggardly. If Mr. Printz or I should say to them, “We want to have a banquet,” they would reply, “Very well, go and have a banquet and we will pay for it.” They like to have us attend these conventions, and when anything comes up that they and we consider an advantage to our Gas Company, they say, “Go ahead.” Whether we could convince them that a banquet was necessary, or of advantage to our gas works or the gas business in general, I am unable at present to say. If there is anything in it that is doing us any good—were we learning anything that was for our own good directly or indirectly, we would have the “cheek” to say to them we wanted it; and even as it is, if we were to say to them that we wanted it they wouldn't “kick.” We ourselves want to stand in as good a light with our Company in the future as we do now, and as when we are away attending these conventions our folks suppose we are looking to their interests, we would not like to shake their confidence.

Mr. McDonald—Mr. President, I being one of the charter members of this Association, have always taken deep interest in its welfare. I am not in favor of places where the Association meetings are held feeling that they have to furnish the Association with a banquet. I have always felt that it would be wrong, and a detriment to the Association, if that were the case; but a resolution of that kind, which says we *will* not accept, to my mind, is not right. I think the banquet matter has been carried too far in many instances. I do not know but that I agree with Mr. Hyde that we could get along just as well without wine. Suppose we went to Zanesville, if you please, or to Cleveland, or to Columbus, and the gentlemen wanted to ask this Association to a social, pleasant time, that might cost \$10 or a \$100 to the proposers, we would be confronted with the fact that on our books stands a resolution saying we will not accept. That would place the Association in a bad position, I think. I would suggest to the Association that this resolution should be modified to the effect that it shall be dependent upon the vote of the Association at the meeting there and then held.

Mr. Graeff—I think that Mr. McDonald forgets that when he was a young man, and used to go out with one of his best girls, and a girl that would occasionally eat ice cream, and he had to press her occasionally to take some, and she refused, and he would say, “I saw you take some a few evenings ago with some other fellow,” then she would go. But if he had a girl that made it a maxim of her life that she wouldn't eat ice cream, she wouldn't go, and he was better off.

Mr. Cantine—I have the honor of belonging to an Association that at its annual reunion follows the policy of paying for its own banquet. It is the custom of all the towns where the reunion is held to provide a hall and all the facilities for having a meeting, but they don't give us a banquet, nor could they do so. Now, you will find that this will militate greatly against this Association after awhile. You will have exhausted all the hospitality there is. This banquet feature will place every company in a bad position. It will, first, have to tender a banquet, then you can decline or accept as you please—you will find there will be no failure to accept—so I think we had better place ourselves on an independent basis. Mr. McDonald represents a big Albany Company and sees no objection to doing these things; but the poverty-stricken gentlemen belonging to this Association find it a little hard on them. Now,

in our case, I have told you just how we stand and there would be no hardship. (Laughter.)

Mr. McDonald—I presume it is well known to all the members of this Association that the New England Association always pay for their banquet wherever they are. They always have one at mutual expense. I think \$3 per plate is their price. A very moderate amount of wine is furnished at these banquets, and every member feels it no hardship to pay the assessment.

Mr. Wilkiemeyer—The resolution offered does not prevent the Association from furnishing itself a banquet. It can do that.

Mr. McDonald—Suppose a dozen gentlemen in a town should organize and want to give the Association a banquet. Would this prevent the Association from accepting it?

Mr. Wilkiemeyer—The resolution says “local companies”—the gas companies. Now, if we go to a manufacturing center where we have half-a-dozen meter manufacturers, we would have no scruple at all about taking a banquet from them.

Mr. McDonald—I am ready to vote for the resolution. (Laughter.)

[The resolution was voted upon and adopted.]

Mr. Penn—Mr. President, I move that the next meeting of the Association be held at Zanesville, Ohio. [Adopted.]

Mr. Printz—I would say to the gentlemen that we have good hotels. Traveling men will confirm what I say in regard to the leading hotel of our place. We have quite a number of places of interest that we will be pleased to show to the members after they have finished their business meeting. I thank you.

Mr. Graef—How is the water there?

Mr. Printz—The water is muddy.

INTRODUCING THE NEW MEMBERS.

The President—Gentlemen, as the Secretary calls the list of new members I wish they would be kind enough to rise in their places and answer to their names.

(Thereupon the Secretary called the roll of new members, and as their names were called they rose in their places.)

The President—Gentlemen, I hardly know whether to introduce you to the old members or the old members to the new. I can say we are glad to receive you, and we welcome you to the privileges of the Association of which you are now members, and trust it may be a matter of mutual profit to us all.

(On motion, the meeting adjourned.)

SECOND DAY—AFTERNOON SESSION.

QUESTION-BOX.

The President—I think we will open our question-box. The first query is: “*At what point in the works is the best place for the exhaust-er?*” This is a matter I have heard quite earnestly discussed very recently, and I think we should be able to get some information that perhaps would be of value to us all.

Mr. Hyde—The exhauster at both of the works—the old and the new—at Cleveland, precedes the condensers; that is, it follows right after the retort house.

The President—You interpose no special apparatus between the exhauster and hydraulic main?

Mr. Hyde—At the old works we have a tar extractor or tar scrubber. At the new works there is nothing.

Mr. Evans—We have the exhauster within 30 feet of the hydraulic main—nothing intervening between the exhauster and hydraulic main.

The President—At the works with which I am connected that is substantially the case. We have a tar scrubber in the line between the exhauster and hydraulic, which is the only interposition.

Mr. Hurlburt—In Oberlin we tried it both ways. In the old works we had the exhauster beyond the condenser, and in the new works about 10 feet from the condenser. We don't calculate to have very much tar in our hydraulic mains; only water. It works a great deal better on the new plan than on the old. We have a reservoir in which the tar lodges, and we draw it off from that.

The President—I will inquire of Mr. Hurlburt if he notices any particular difference in the action as to the different points at which it was placed?

Mr. Hurlburt—The difference is in the condition in which we get our gas to the purifier. In using it now next to the hydraulic we have no trouble.

The President—The second question is, “*In a lighting territory covered by illuminating gas and the incandescent electric light, which seems to be in the ascendancy?*”

Mr. Hyde—At Cleveland gas has the ascendancy.

The Secretary—I think that at Columbus, in the territory covered by both our gas and the Edison incandescent electric lights, the gas bills amount to more than the electric light bills.

Mr. Booth—I will ask Mr. Butterworth whether they did not occupy that territory before the electric light company did?

The Secretary—Yes, sir; that would be the case in almost any city that has the incandescent light.

Mr. Penn—I don't think the Edison company is a competitor of the gas company.

Mr. Cantine (addressing the President)—What is the case in your city?

The President—Mr. Hyde has stated the case very fairly, and I don't know that I could add anything to it. The statements he made would perhaps be a little more true on our side of the river than on his. We are the smaller part of the city—a sort of attachment—separated by a geographical line in the shape of a river. I think the electric lighting there is relatively smaller than it is on the other side of the river. In fact, I don't know of an instance of incandescent lighting there, and the population is perhaps 80,000.

Mr. Cantine—My judgment, Mr. President, is that gas is largely in the ascendancy in all the smaller towns and cities. In cities with 15,000 or 20,000—at any rate, the smaller cities of 8,000 or 10,000 or 15,000—I think gas will always be in the ascendancy, and I doubt whether any company could maintain a plant for any great length of time with the incandescent light solely. They are difficult machines to handle. It is difficult to keep the energy at one thing. As far as some of them are concerned, the cables are so large that it makes the capitalization so great that they can't get their money out of it. I think in the smaller towns few of us have any apprehension of being smothered by the incandescent light. It is true the arc light will be used for lighting streets. It is a large light, and a very brilliant one; but I think there is no apprehension that the electric lamp will hurt us. We have in our town a little opposition, but it is growing less each month. In very many of the business houses they have gone back to gas, until there are only a few now using the electric light.

The President—I will read another question. It is in the same general line, and has been called for by a member who has to leave soon. It is this: "*What system of electric lighting is best for adoption by gas companies?*"

Mr. Penn—I would ask what the question means; whether it means incandescent or arc system, or some particular make of machine.

The President—Manifestly the question is of systems, as between the Edison, the Thomson Houston, the Brush, and Westinghouse. That would be my interpretation of it.

The Secretary—That is mine. It seems to me, Mr. President, that that system which would be best for adoption by an incandescent electric lighting company would also be best for adoption by a gas company; and since Mr. Penn has expressed the opinion that the Edison is hardly to be considered a competitor of gas, it must be some other system than the Edison. We will eliminate that, then.

Mr. Penn—I would say the reason I do not consider the Edison a competitor of the gas company is because it costs too much to install a plant to cover any considerable area. We all understand that—it has been discussed thoroughly before. Of course, other systems come in—the alternating system—which covers a large area, and they can run at a less expense than the Edison. That is the reason why I say the Edison is not a competitor of gas companies. While they give a good light, yet the expense of running is too great, especially where they have cheap scales, as in Columbus. As far as the other systems are concerned, I found out, when I was investigating as to what system to buy when that competition commenced with us, that they all had the best system—like the woman with the sewing machine. They all have the best sewing machine. It is pretty hard to say which is the best system.

The Secretary—But you would say it would be a high tension system.

Mr. Penn—That is the kind I would buy, if I bought.

The President—The next question is, "*Does a fine gas of 23 to 25-candle power help check the invasion of the incandescent electric light?*" Now, what are the opinions of those who have had experience in that regard? I would suggest that Secretary Butterworth could perhaps give us something on that score.

The Secretary—It would be hard to make a 25-candle power coal gas at Columbus that would not smoke. One would suppose that, theoretically, a high candle power gas would have a tendency to check or retard, in a measure, the invasion of incandescent electric lighting. Yet I have been told that in those cities where the candle power of gas is

highest, the incandescent electric light seems to thrive as well as in cities where the candle power of the gas is lower.

Mr. Graeff—I certainly think that a high candle power gas is one of the best means in the world of checking the incandescent electric light.

Secretary Butterworth—How about the progress incandescent electric lighting is making in Baltimore, Mr. Graeff? They have a high candle-power gas there.

Mr. Graeff—I am too good a friend of Frank Hambleton's to answer that question.

Mr. Evans—In my judgment the incandescent electric light has its field just as much as gas has, and there are people in certain manufacturing business, perhaps, or offices, who would pay a larger price for incandescent electric light than they would for gas. Some complain of the heat. Others say the electric light is preferable on account of its convenience—no matches, no danger of fire, touch a button and your light is ready, touch another one and it is out. I know that in Jackson, in trying to win back a very large consumer of the incandescent electric company, they wouldn't have anything to do with gas whatsoever, because a few years ago they had a fire. It is a very large dry goods store, with drapery goods largely, and a few years ago some lace happened to get into the gas flame and ignited, and the loss was some \$35,000. They were willing to pay a larger sum for incandescent electric light, and in fact refused to have anything to do with gas whatsoever. I think that condition exists more in large cities than in small cities. I don't think incandescent electric lighting is progressive in small cities at all. In fact I think it is going down hill. But in larger cities, where they can afford to pay for the luxury and convenience of it, I think it is advancing. I know it is in Chicago, and I made a great many inquiries in that direction.

The Secretary—But a high candle power gas would have a tendency to check it, even in large cities.

Mr. Evans—I believe so; yes, sir, with canvassing back of it.

Mr. President—The fourth question is, "*Should we not confine the work of our Association to the important interest it was established to promote, viz., gas lighting and the manufacture of coal gas?*" Now, we have some here who manufacture something besides coal gas. It would seem we ought to be able to bring out some points from this question.

Mr. Hyde—From the reading of this question two constructions could be placed upon it. It says "Gas lighting and manufacture of coal gas." Now, if it had said, "Gas lighting and manufacture of gas," it would be all right; or "coal gas lighting and manufacture of coal gas." As it reads we don't exactly know what the writer intended.

The President—May be that ambiguity was placed there purposely.

The Secretary—The question is ambiguous; but I think the author's idea was that technical light papers, or technical water gas papers should not be encouraged here.

Mr. Hyde—What was the object of this Association? Did it read "Coal gas" or "Water gas?" Was water gas left out?

The Secretary—The constitution simply says "Gas." The object of this Association was to be the "promotion and advancement of knowledge, scientific and practical, in all matters relating to the construction and manufacture of gas works, and to the manufacture, distribution and consumption of illuminating gas, to the end that its cost may be cheapened and its consumption increased."

Mr. Hyde—I would say we ought to do just what this question calls for—confine our work or the work of the Association to the important interests of manufacturing gas. I think that is what we are here for, and I think we should not be talking or discussing anything else than the manufacture of gas and things pertaining to it. We should not discuss railroads, or anything of that kind, but only the manufacture of gas.

The President—The next question has already been partially anticipated. It reads: "*Are cast iron pipes better and cheaper than wrought pipes for gas mains of two to four inches in diameter?*"

The Secretary—A manufacturer of cast iron pipes in Columbus said, when I showed him this question, that he would not recommend a 2-inch cast iron pipe, although he was a cast iron pipe manufacturer; that the tapping of a 2-inch cast iron pipe weakened it, and it was liable to break, etc. Even as to 3 and 4 inch pipes, it was a question with him whether cast was any more durable than wrought.

Mr. Penn—He was not interested in wrought iron?

The Secretary—He is a cast iron pipe manufacturer.

The President—I see Mr. Ranshaw here. In talking with him this morning he gave a little account of some purifying boxes made of sheet metal rather than of cast iron. I wish he would repeat, for the benefit

of the members, what he said to me; and perhaps he can add to that.

Mr. Ranshaw—I alluded to some wrought iron purifying boxes that had been in use not less than 20 years, and which are still in use. They were made out of, I believe, $\frac{1}{2}$ -inch boiler plate—the sides and bottom, if I remember rightly, are three-eighths—and the water seals are made in the ordinary way. These boxes are in use now in the Cumberland gas works. A number of others (smaller ones), 6 and 8 feet, were shipped to different parts of the country.

Mr. Penn—Mr. President, I would ask if wrought iron pipes will not rust out quicker than cast iron from the alkali of the soil? Some soil has more alkali than others. Does not that have an effect upon the wrought iron which it does not have upon the cast?

The President—I think all of us have noticed the difference in the life of wrought pipe according to the soil in which it is placed. For instance, I think Mr. Hyde could give us an account of the very rapid deterioration of pipe laid in a certain locality. We also know that many times a service pipe meets with disaster, and what causes the difference seems almost incomprehensible, but we generally find there is a made soil there—an ingredient in it or something that accounts for the change, if we investigate carefully. The same is true of natural soil, and there is no question that there is a vast difference between a sandy, gravelly soil and a clay soil, with reference to the life of wrought pipe. The life of a cast iron pipe has perhaps hardly been determined in the gas business. Some original pipes are still in the ground and come out all right on latest investigations.

Mr. Penn—What kind of soil is the hardest on pipes, clay or sandy?

The President—Well, my own idea of the thing is that a pipe will last longer in a clay soil, as a rule.

Mr. Penn—That is my experience.

Mr. Hyde—At Cleveland we have had a peculiar experience. At Newburgh, where the rolling mill has been in operation for 30 years, wrought iron service pipes will not last more than a year or so. They are eaten right through. Where there is ashes or coke dust, or pieces of coke, or refuse from a furnace, or anything of that kind, to make contact with the iron, it is very quickly eaten through. At Newburgh, in the eastern part of our city, all the service pipes are now laid in and covered with lime. We take a little trough, put something in it to hold up the pipe, pour it full of water lime, and then plaster it all over so that it is perfectly covered. That preserves it. I don't think I am mistaken in saying otherwise they will not last more than a year until eaten through. Cast iron is not affected that way. I think, as a rule in our city, that we would not wish to use wrought iron pipe of any size for mains. All our services are of wrought iron and, ordinarily in the sand, we experience no particular difficulty; but when we get into some place where ash or coke dust is found, as in Newburgh, we have to protect them. In the ordinary sand they will last apparently an indefinite length of time. We used to lay 2-inch cast iron mains, but it is useless to lay a 2-inch main. It is too small to be tapped. Our smaller mains, as a rule, are 4-inch, and we lay water works weight—a heavy weight—so that we can tap them with impunity. We don't cover our mains—that is, they are not coated with tar.

A Member—Is it not the sulphur that eats through those service pipes?

Mr. Hyde—I think so.

A Member—Wouldn't the use of oxide in your purifiers have the same effect on them that the ashes and stuff would on the service pipes that you speak about? You spoke about your purifiers lasting so long; do you use lime in them?

Mr. Hyde—Yes, sir.

A Member—Any oxide?

Mr. Hyde—No, sir, I think not.

A Member—Well, if you used oxide they wouldn't last any time.

The President—I would like to ask Mr. Hyde if possibly this condition in Newburgh may not be due to the fact that the iron works are located there?

Mr. Hyde—I think the whole atmosphere is filled with this sulphur gas—all the deposits and rain and everything are filled with it. The ground is permeated with these particles of combustion from the coal. One hundred tons of fuel are used every day in the mills at Newburgh.

Mr. Penn—They manufacture copperas, using sulphate of iron?

Mr. Hyde—Yes, sir.

Mr. Penn—That will destroy the iron very rapidly.

Mr. Cantine—Mr. Hyde has spoken about the difficulty of making a good tap in a two-inch main. We find no difficulty whatever in doing that, by the aid of a little device which we use. (Mr. Cantine here described his device.)

The President—I would say that in our experience we have found

more difficulty from the fact that the pipe is very much weakened—a three-inch pipe especially. It has been a long time since I have put in anything larger than an inch hole, and I dislike to do that. With the disturbances that come from water and sewer connections and the like, we find that very frequently a three-inch pipe is broken where it is tapped, no matter how thick it is. Even if tapped on the thick side of the pipe, the pipe is liable to be broken. Our 7th question reads, "Does it pay to coat gas mains with coal tar?"

Mr. Hyde—We do not think it advisable to coat gas mains—they last long enough anyhow, but there is another objection with reference to coating gas mains. Do not order your mains tarred at the factory where they are made, because if you do you will regret it. You perhaps all know that at the foundries where they coat the water mains, they dip them, and that coats the socket and the spigot—the whole main—inside and out. I suppose you all know that the gas puts the tar coating in such a condition that it will run. It finally is disintegrated, runs down into the bottom of the mains and flows on as far as it can and stops up everything. More than that, in pouring a lead joint, the hot lead melts the tar and the tar rises or comes to the top. The last lead that enters the socket holds that tar there—it is not simply a thin coating at the upper part of the bowl, but a thick quantity—the joint is driven up, and after a space of time, say six months or a year, the gas operates on that tar, liquefies it, and it runs out, and you then have an open joint. We had a most unfortunate experience of this kind. We laid a 24-inch main and a 16-inch main that way, and I suppose in the course of two years every joint had to be made over or caulked up. We had to dig down and cut the tar out, and then drive the joints up again? Through $1\frac{1}{2}$ miles of 24-inch pipe, and two or three miles of 16-inch pipe, I suppose every joint has been gone over the second time; and we thought it of so much consequence that in speaking with foundry men we say, "Don't ever dip a pipe for a gas main. If he orders a pipe dipped, tell him you will not do it, because if he is not posted he will get posted before he gets through with it, and you had better post him beforehand." We have taken some pains to advise foundry men not to dip pipe for gas men. Perhaps you all know about this, but if you don't, you had better regard it, or you will have experience that you will regret. We have had all we want of it.

Mr. Penn—I would like to ask if that applies to wrought iron pipes?

Mr. Hyde—It does not apply to wrought, because wrought iron is made with a thread.

Mr. Penn—I mean without coating on the outside. Will they last forever, like cast iron?

Mr. Hyde—No, sir; the wrought iron pipe ought to be coated. A mixture of red and white lead, I suppose, would be the best of anything. That seems to be indestructible and everlasting.

The President—What Mr. Hyde has stated with reference to the joints of tar-coated cast iron pipe I can indorse as true and worthy of the most careful consideration. Our Company has not so extended an experience as Mr. Hyde's people, but we have had all we want. On one occasion we had to put in some tar-coated pipe. We did not cut out, as Mr. Hyde describes, the joints in the first instance—that is, the upper part of the joints, where there is a kind of spongy mixture, more or less lead and tar. As it boils up there it forms a kind of porous condition of the lead, and you may caulk it up and within a year you must do it again; and if it were not cut out it would keep on doing that.

Mr. Hyde—I did not say we cut it out; we drove it up.

The President—Did not you find it necessary to take something out there?

Mr. Hyde—No, sir; we drove it up. We have latterly driven a heavy chisel in. We find it easy to do, and put a big wedge into the top of every single one of these pipes. Whenever we open them now we resort to that as a means of saving another opening.

(To be continued.)

Public Street Lighting in New York.

E. G. Love, Ph. D., Gas Examiner for this city, recently prepared the following interesting paper on this subject for the *School of Mines Quarterly*. Doctor Love wrote:

The first attempt to light the public streets of New York with gas was made in 1823, when a contract was executed with the newly organized New York Gas Light Company. The contract granted to the Company the exclusive privilege, for a term of 30 years, of supplying gas to that portion of the city lying south of Grand street. The cost of each public lamp was not to exceed the amount paid for 1 oil lamp. This contract expired by limitation in 1853, and another one was made for a period of

1 year. It was similar to the first, except that the exclusive right to the territory below Grand street was omitted, and the price to be paid for lighting the lamps was fixed at \$15.47 each per annum for 2,300 hours, with a corresponding increase in price for any extension in the number of hours.

The practice up to this time had been not to light the lamps on moon-light nights, but late in 1853 the Common Council directed that the public lamps should be lighted on every night of the year. This increased the number of hours of lighting to 3,833, and the cost of each lamp to about \$25 per annum. The number of hours lighting remained at the figure given until 1879, when it was increased to 4,000, and has been without change up to the present time.

Some 10 years after the introduction of gas lamps in the city, the Manhattan Gas Light Company was organized, and in 1833 obtained a grant and contract to light that portion of the city lying between Grand street and Sixth street, the same to continue for 20 years.

Owing to the rapid growth of the city, an extension of the lighting system became necessary. To this end the existing contract with the Manhattan Company was cancelled in 1848, and another one made for a period of 20 years, in which the territory was extended to Forty-second street. As in the former contract, the price per lamp was fixed at \$15 per annum for 2,300 lighting hours, or \$25 for 3,833 hours. This second contract was cancelled by mutual consent in 1865, and for the 8 years following the city's streets were lighted under short contracts or none at all. During most of this period the gas companies, profiting by a decision of the Court of Appeals, charged \$53 per lamp per annum.

In the years 1855, 1858 and 1868, the Harlem, the Metropolitan and the Mutual Gas Companies, respectively, entered the field, already sufficiently well filled, and received their grants to tear up the city's streets, under the mistaken idea that an increase in the number of companies and the amount of capital invested would give the consumer cheaper gas.

The amended city charter of 1873 authorized "the Commissioner of Public Works, in conjunction with the Mayor and Comptroller" (commonly known as the Gas Commission), to make contracts for lighting the streets, avenues and places of the city with gas, but limited the contracts to 1 year. Under this Act contracts were made for the year 1874 at greatly reduced rates, which have continued up to the present time.

For convenience in connecting the public lamps with the gas mains, the Gas Commission was authorized in 1878 to determine when the year for the lighting contracts should commence, so that now all contracts for lighting the public lamps date from May 1st to the April 30th following.

The contract prices in 1888 were \$17.50 per lamp by the Consolidated and Mutual Companies, and \$12 by the Equitable Company. In the case of the latter Company, the franchise fixes the price given as a maximum. Companies lighting the public street lamps beyond Harlem river receive \$28 and \$29 per lamp.

The first movement looking to the public lighting of New York by the electric light was a resolution adopted by the Common Council in February, 1879, requesting the Gas Commission "to have experiments made to test the practicability of lighting" the streets and parks of the city with the electric light, and to determine the relative cost of gas and electricity for this purpose. As the experiments were to be made without expense to the city, nothing was done under the resolution.

Early in November, 1880, however, the Brush Electric Light Company asked permission to erect lamp posts on Broadway, from Fourteenth street to Thirty-fourth street, for the purpose of demonstrating the suitability of the electric light for street illumination. This request was granted, and on the 15th of January following 22 arc lamps were lighted by the Company, and continued without expense to the city until the 1st of June. While these lamps were far from perfect, the experiment promised sufficiently well to warrant the Gas Commission in making a contract with the Brush Company. Fifty-five lamps were lighted under this contract, at the rate of \$7,400 per annum.

Another contract was made with the Brush Company for 1882, and also one with the United States Electric Illuminating Company. The price paid by the city was 70 cents per lamp per night, or \$255.50 per annum. This continued to be the price up to May 1, 1887, the number of lamps being increased each year. Thus, on the 31st of December, 1882, there were 128 electric arc lamps in use; in 1884, 647 lamps; in 1886, 711 lamps; and in 1888, 1,328 lamps.

Previous to 1887 the contracts were awarded to the two companies already mentioned; but a number of new companies now entered the field, and the contract price in 1887 varied from 19.9 cents to 50 cents per lamp per night. The prices paid in 1888 varied from 32 cents to 60 cents per lamp per night, the average being 35.2 cents.

To arrive at the comparative cost of gas and electric light for street illumination we may take the years 1885 and 1888—in the former the price being 70 cents per lamp per night, while in the latter it averaged 35.2 cents.

The number of gas lamps replaced by each electric light will naturally be subject to some variation, but the average, based upon the introduction of a large number of electric lights, is $4\frac{1}{2}$ gas lamps for each electric lamp. At the close of 1885 there were 708 electric lamps in use, equivalent to 3,185 gas lamps. The cost of the electric lamps at \$255.50 each, on the supposition that no reductions were made for extinguishments, would have been \$180,894. The price paid for the gas lamps replaced was \$17.50 each per annum, and if to this we add \$1.60 for supplies, etc., we obtain \$19.10 as the cost of each gas lamp, or \$60,852.60 for the total number of lamps replaced. The lighting by electric lamps, therefore, cost \$120,041.40, or 66 per cent. more than would have been paid for the less brilliant illumination by gas.

On the 31st of December, 1888, there were 1,328 electric lamps in use, at the average price of \$128.48 per annum, or a total cost of \$170,621.44. They replaced 5,976 gas lamps, costing, with supplies, etc., \$19.14 each per year, or a total cost of \$114,380.64. In this case, where the prices charged for both gas and electric lamps were about as low as we may expect to see them—for the present at least—the excess in cost of the electric lamps over the gas lamps was \$56,240.80, or about 33 per cent. It is therefore apparent that whatever may be the advantages of the electric light over the ordinary gas lamp for street illumination, we are obliged to pay liberally for these advantages; and it becomes a question to what extent it is desirable to replace gas lamps by the more intense but less reliable electric lamps at an increase of one third in cost.

As showing the demand for this greater illumination, it is interesting to note that in 1885 the Common Council passed various resolutions requesting the Gas Commission to light certain streets and avenues with the electric light. The Superintendent of Lamps and Gas estimated that had it been possible to comply with these requests it would have taken over 2,000 lamps, costing \$526,840, and have replaced gas lamps costing \$89,862.50; an excess in cost of the electric light over the gas lamps of \$436,977.50—more than one-half of the entire appropriation for public lighting.

As regards comparative illumination, it is not necessary to say that the electric light is much superior to gas; indeed, in New York the street lighting by gas is not what it ought to be. The first contract made with the New York Gas Light Company, in 1823, specified the burner to be used as one capable of passing 3 feet of gas per hour; and while repeated efforts have been made to increase the capacity of the burner to 4, 5, or 6 feet per hour, we are, in this respect, precisely where we were more than 60 years ago. And yet during this period the candle power of the gas supplied has been nearly doubled; so that to-day our street lamps give a light of from 10 to 16 candles for 3 feet of gas.

In the early days of electric lighting it was commonly said that the ordinary arc lamp gave a light of 2,000 candles, but such is not and it never has been the case. The arc lamp gives less light horizontally than in a downward direction, and when these lamps were first put upon the market some one measured, or, more probably, estimated the intensity in a horizontal direction at 500 candles, and then, to make a good showing, multiplied it by 4, making the 2,000 candles. While the 500 candles was pretty clever guessing, there was no good reason whatever for multiplying it by 4 any more than by 360.

As the amount of light thrown upon the walk and roadway is of more importance than that emitted in a horizontal direction, the present city contracts with the electric light companies require that the lamps shall give a light of at least 1,000 candles at an angle of 40° below the horizontal. Measurements which have been made of the lamps of some of the companies give from 1,300 to 500 candles.

Of late an attempt has been made by one of the gas companies to introduce a large regenerative gas burner—the Gordon—for street illumination. It has been tried on parts of Fifth and Madison avenues, and Forty-ninth and Fiftieth streets, with very satisfactory results, and without expense to the city. An arrangement was made to light Lenox avenue, from One Hundred and Tenth street to One Hundred and Twenty-ninth street, with 75 of these lamps, during the month of December. The expense of this installation, however, which is \$5 per lamp per month, will doubtless prevent its extension.

The recent extinguishing of most of the electric lamps, and the consequent darkness on many of our thoroughfares, calls public attention especially to this subject of street lighting, and shows the importance of keeping the gas lamps in a condition for immediate use, certainly until the electric light has become more thoroughly domesticated.

Thwaite's Gas Fired Boiler.

The boiler herewith illustrated is being introduced by the Gaseous and Liquid Fuel Supply Company, of Liverpool, Eng., and is the invention of Mr. B. H. Thwaite. The cut shows a 30-horse power steam generator designed to be heated with gaseous fuel, such as producer gas. The gaseous fuel is generated in a Thwaite gas generator, but the latter can be placed immediately below the steam generator. Where there is a series of these boilers it is advantageous to generate the gas in separate vessels.

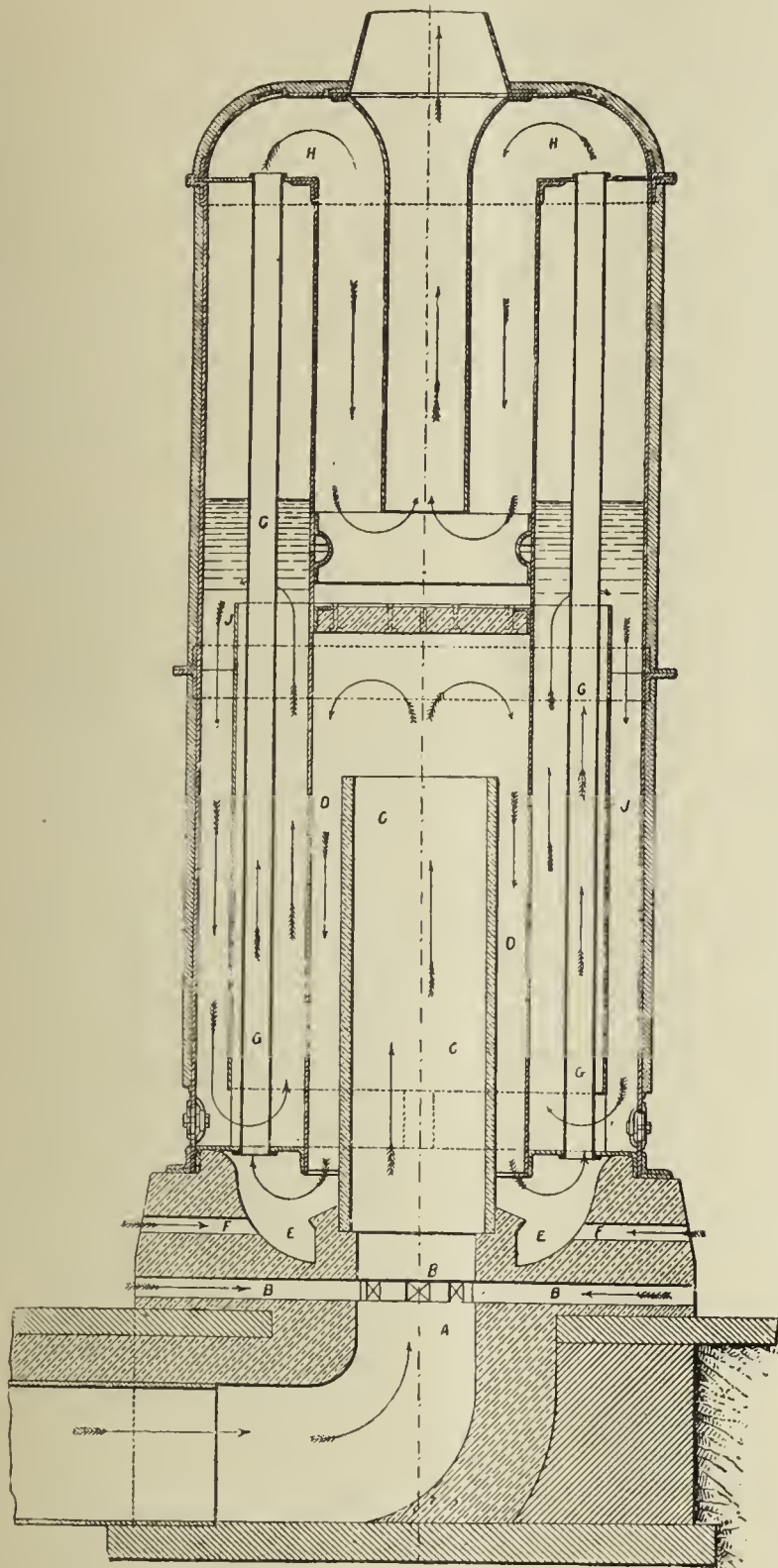

The gas ascends into a vertical combustion chamber A, meeting a supply of air issuing radially and uniformly from air tubes B, at the level of which combustion ensues, the flame flowing upward inside refractory tube C, which becomes heated to bright incandescence. The flame passes over the upper edges of this combustion tube C, and descends the annular space D formed between the flue plate and tube, the ring of flame being in close contact to the water-covered surface of tube. The combustion is completed in the annular chamber E, which is provided with a secondary air supply by means of the radially-placed air tubes F. The gaseous products of combustion ascend through the tubular part of the generator G into the upper chamber H, when they are diverted and directed downward around the inverted tube I, around which they circulate in contact with the steam-covered surface of the boiler flue plate, superheating the steam and enabling the full practicable absorption of the sensible heat from the gases of combustion to be obtained. The arrows clearly show the direction of flow of gases to the chimney.

It will be seen that the maximum temperature and the flame combus-

tion is next to the water-covered surfaces, only the products of combustion with their sensible heat being next to the steam-containing portion of the generator. It will also be noticed that practically all the heating surface is vertical. The circulating arrangement of this generator is most simple and effective. An annular ring or curtain J is provided, dividing the ascending and descending currents. The latter flow next to the outer casing, sweeping the tube-plate and flowing with great velocity over the surface of the combustion flue. The velocity of circulation is such as to prevent the deposition of any calcareous material, all that is required to maintain the internal heating surfaces free from scale is to blow off the boiler once a week. The perfection of combustion enables the boiler to work without the necessity of cleaning the tubes. The rate of evaporation can be maintained almost absolutely constant. The boiler is provided with Heffner's safety Popp valve, which was tested at various pressures up to 95 pounds to the square inch in this boiler, and gave satisfactory results.

ITEMS OF INTEREST FROM VARIOUS LOCALITIES.

THE proprietors of the Hoosick Falls (N. Y.) Gas Light Company have determined to reduce the net selling rate to \$2 per 1,000 cubic feet.

AT the annual meeting of the Royal Electric Company, of Montreal, Canada, the following officers were elected: President, Hon. J. R. Thibaudeau; Vice-President, W. J. Withall; Directors, the officers and Messrs. G. R. Robertson, E. A. Small, J. A. Strathy, W. Cassils and F. L. Beique. While the financial reports submitted were "generally considered satisfactory," we have it on good authority that the balance sheet shows no evidence of very pronounced earnings. Further, it would be rather strange if it did, since the local Gas Company's good and cheap gas seems to be in great favor with the residents, even though the city authorities are willing to strain a point—if not more—in favor of aiding and abetting the electricians in respect to the public lighting.

WE are informed that the Cincinnati Gas Light and Coke Company has arranged for the construction of a large gasholder, to be located at the corner of McMillan and Church streets, in the Walnut Hills district.

A SUIT that is attracting considerable attention in Philadelphia is one brought in the local Court of Common Pleas, (No. 2), by A. H. McNeal, the pipe founder of Burlington, N. J., against the Director of Public Works (Gen. Wagner) for \$50,000 damages "for defamation of character and injury to complainant's business reputation and credit." The suit, according to our local advices, is based upon a remark said to have been made by Director Wagner when, on the fifth of last November, he rejected a bid for gas pipe tendered by McNeal. This particular bid was considerably lower than that of any other tender submitted in the competition, and when it was opened the Director ordered that it be thrown aside, at the same time remarking, "This bid will not be considered, because this man McNeal has committed a criminal offence in altering a city contract which was awarded him some time ago." Our authority then goes on to say: "In explanation of what the Director meant, Richard P. White, counsel for Mr. McNeal, says that on March 5th, 1889, McNeal was the lowest bidder, by several thousand dollars, on a very large contract for gas pipe, the task of delivering which was to commence at once, and to be completed on the 1st of July following, under a forfeiture for delay. The contract was awarded to Mr. McNeal, who was notified by Chief Engineer Park, on the 7th of March, of the award. He answered at once that he was ready, but would not furnish any pipe until the contract had been signed. He wrote repeatedly to urge the preparation of the contract papers and finally, after they had been delayed over two weeks, he notified Director Wagner that he would not sign the contract unless there was included in it a provision extending the time for the delivery of the pipe for as long a time as the papers had been delayed, or for a release of the forfeiture. The Law Department, at the close of the month sent him a blank form of contract, before signing which Mr. McNeal inserted the clause upon which he insisted. The form thus signed, but unsigned by any one else, was returned to the Department of Public Works. Director Wagner refused to sign it with the clause inserted by McNeal, and ordered the pipe from the firm of R. D. Wood & Co., under a contract to have the pipe delivered by November 15, at a cost said to be \$2,005.29 more than the same pipe would have been delivered by McNeal, before August 1, if the Director had allowed McNeal for the delay claimed. Of course, it must be remembered that the foregoing is but a reflex of the opinion of Mr. McNeal's attorney, and take it all-in-all, I fail to see wherein the

Director has not the best of the thing all the way through in the matter of a plain business proposition, for I fail to see where Mr. McNeal could justly think himself entitled to alter a contract, the specifications of which were under the framing of the city authorities. At this point, however, one must cease to defend General Wagner, in so far as anything detailed above can be construed in excuse of the remark attributed to the General, that McNeal had committed a criminal offence. It, however, is but another instance of how far an irascible temper may embroil a man; and it may be taken for granted that Director Wagner is not over-choice sometimes in choosing words expressive of his dissent. I might be forgiven, too, for remarking that it is almost time he arrived at the knowledge that the language of the camp is not best suited for the expression of a business verdict.—QUAKER.”

FIFTY new passenger coaches, to be lighted by the Pintsch system of compressed oil gas, have been contracted for by the New York Central & Hudson R. R. Co., to be delivered at an early day.

IT is probable that Manchester, Va., will be lighted with gas in a few months. In any event, the scheme for the construction of a gas plant there has been revived, and one of those most prominently identified with the resurrection is Mr. John C. Robertson, General Manager of the Southside Land and Improvement Company.

THE Paterson (N. J.) resident whose monthly consumption of gas aggregates 5,000 cubic feet or upwards is to be granted a certain rebate from the present net price. The Gas Company will also institute a system for the regular inspection of consumer's burners, fixtures, etc.

THE proprietors of the Kansas City (Mo.) Gas Light and Coke Company have filed plans for the construction of a brick, boiler and engine house, to be located at 25th street and "State Line," the estimated cost of which is \$40,000.

THE residents of Everett, Mass., are clamoring for the right to operate an electric lighting plant on town account. They now pay \$90 per annum each for arc lights, and \$18 for incandescents (16-candle power), on a lighting table (moon-schedule) that ends at midnight.

THE Gas Lamp Committee, at a recent meeting of the Wilkes-Barre, Pa., City Council, submitted a resolution providing for the abandonment of all public electric lights, and the substituting therefor of gas and naphtha lamps. This proposition created quite a stir in the meeting room, and Mr. McCartney was quite pronounced in opposition to the measure. He thought that Wilkes-Barre would be disgraced in the event of its casting out electricity, and that no Alderman could give any good reason why such a course should be adopted. Mr. Lavin thought that Wilkes-Barre could not afford to bankrupt itself for the sake of maintaining electric lighting; and that the present system was decidedly inefficient. Again, if the system was to be followed it would have to be extended, since it would not do to make fish of the residents of one Ward and flesh of those in another. Mr. Long, on behalf of the electric light suppliers, said the rates charged were not excessive, and that the service was fully up to standard. Mr. Mahoney thought the city ought to be equally well lit in all of its divisions, and was decidedly opposed to having electric lights in one Ward and naphtha lights in another. He thought that an improved system of gas lighting would be acceptable to the citizens; not only so, but that it would be far cheaper than the present hybrid plan. Mr. Lavin said that under the present conditions one-third of the city absorbed three-fourths of the lighting appropriation. When the debate was closed, by means of a motion to lay the report on the table, the latter was determined on by a vote of 10 to 9. A pretty close shave for the electricians; but not so close as they may look forward to in the near future.

ALTHOUGH the figures would indicate something of the imposing order, we imagine there is more of buncombe in them than of real value, which opinion is advanced in connection with the suit of Col. James M. Clark, who asks for the appointment of a receiver for the Michigan Gas Company (nominal headquarters at Detroit), in a suit begun in the Circuit Court. For the transfer of Ohio rights and the franchise for the right to use the streets of Detroit he alleges that the Company was to give him \$30,000 and one-sixth of its stock. As they are said to have transferred \$2,500,000 in stock to the Interior Construction Company, he wants the matter looked into.

ACCORDING to the Indianapolis (Ind.) *Journal*, the Electric Lighting and Gas Heating and Illuminating Company, of that city, has filed

notice with the Secretary of State of its intention to extend and enlarge the objects of the Company, so as to include the business of mining, drilling, sinking and operating wells for natural gas, petroleum and minerals. This Company, which is the successor of the three corporations that recently operated the Indianapolis Gas Light and Coke, the Citizens and the Natural Gas Companies, is incorporated by Messrs. C. E. Benedict, Chas. F. Dieterich, E. J. Jerzmanowski (New York), and Messrs. Henry Decker, S. W. Pray and H. E. Pickett, of Indianapolis. The *Journal* intimates that Mr. Pray will be appointed Secretary, that Mr. Decker will act as Cashier, and that Mr. Pickett will act as General Manager of the natural gas plant.

A "VOTER," in writing to the Rutland (Vt.) *Herald*, says: "Below is a sample of how villages are deceived regarding the cost of putting in electric light plants, to be operated on municipal account, and Bangor (Me.) is selected as the instance. Its city charter enables it to use certain water power. Assuming this power to be sufficient, an estimate was made of \$17,000 to equip the city with a plant of its own, and afterwards \$3,000 was added for contingencies, whereupon the city committed itself to the scheme. The lowest bid received, however, was reported at \$26,000. The water power was found inadequate, requiring a steam plant in addition, costing \$5,000, and an additional \$10,000 is now required to make the plant answer the city's needs, or in all, \$41,000, as against the estimate of \$20,000 on which action was first based. Do the taxpayers of Rutland want to be burdened with more taxes for a wild scheme of this kind?"

REFERRING to the opinion of Assistant Corporation Counsel Darrow, of Chicago, in respect to the right of the city to regulate the price to be charged for gas by the various gas companies doing business there, it is found that his adverse decision rests on the basis that, while the City Council would without doubt have power to prescribe by any ordinance, giving to any gas company the right to use the streets, terms and conditions upon which such right could be exercised, it would not have power to control the charges of gas companies to private individuals when no conditions were imposed at the time of granting the right to said companies to occupy and lay their mains in the streets.

WE are called on to record the death of Mr. Thomas Earle, at one time a prominent figure in business circles in Jersey City, N. J. Deceased, who was in his 91st year, had for years acted as President of the Jersey City Gas Light Company, and when in control of its fortunes managed them judiciously. He had been City Treasurer for 15 years, and had been a member of the Board of Aldermen for 10 years. He was also Vice-President of the Hudson County National Bank.

THE Philadelphia Gas Improvement Company, of which W. L. Elkins, Jr., is President, is the corporation that is interested in the recent grant for a works to supply gas in the suburban Chicago towns of Cicero, Oak Park, Harlem and Austin. A plant with a capacity of 1,000,000 cubic feet per day is talked of; but this is probably a trifle, if not more, in excess of the real mark.

THE Iron City Gas Light Company (capital, \$5,000) has been incorporated at Pittsburgh by Messrs. J. B. Griggs, W. M. Cooper, J. M. King, H. L. Trees and J. H. Young.

THE proprietors of the Brattleboro (Vt.) Gas Company have decided to add a 650-light Thomson-House incandescent type dynamo to their present arc lighting outfit.

THE 2 per cent. dividend declared by the Citizens Gas Light Company, of Wakefield, Mass., is now payable.

MR. LINCOLN HAMMETT has resigned the position of Superintendent of the Warren (R. I.) Gas and Electric Light Company.

THE plant addition to generating house of the Spencer (Mass.) Gas Company, now in process of construction, will enable the Company to deliver 40,000 cubic feet of gas per diem.

AT the annual meeting of the Consumers Gas Company of Newburgh, N. Y., the following Board of Directors was chosen: Joseph H. Berry, Detroit, Mich.; O. H. Lawrence, Fitchburg, Mass.; and Capt. John C. Adams, Isaac L. Corwin, and Benj. McDonald, of Newburgh.

THE offices of the Birmingham (Ala.) Gas, Electric Light and Power Company have been removed to 1805 Second avenue, which change will greatly tend to the convenience of its customers.

OWING the large increase in its business, the Berlin Iron Bridge Company, of East Berlin, Conn., has made important changes, both in the instance of its officers and in the details of its business. Mr. Burr K. Field, who had served it as Vice-President and Treasurer, resigned the latter office, and Mr. F. L. Wilcox, of Berlin, was named to the vacancy. The new Treasurer was formerly Manager of the Kensington factories of the Peck, Stow & Wilcox Company, and is well and favorably known throughout New England as a brisk and safe financier. Mr. Field will devote his entire attention to the constructing department, which has of late years assumed very large proportions—its sales last year amounted to almost a million of dollars. All the other departments will, as heretofore, be under the direct supervision of the President and Chief Engineer, Mr. Charles M. Jarvis, ably assisted by Mr. Mace Moulton as Consulting Engineer, and Mr. S. W. Bowles, Jr., as Superintending Engineer. The Company's specialty, in which gas men are most interested, is its improved system of iron roofs for retort houses, etc.

THE Directors of the Lowell (Mass.) Gas Light Company have chosen Mr. George W. Farnham to succeed the late Oliver E. Cushing as Agent. This appointment is one that does credit to the proprietors of the Company, in that it is the promotion of a man who has for years faithfully served the corporation in lesser capacities. That he will fill the bill is beyond doubt, for everything committed to his care in the past was completed in honest fashion. We congratulate Mr. Farnham, and the Company, too.

MR. J. L. HALLETT, of Springfield, Mass., is on his way home from a few weeks outing, chiefly spent in Colorado and California. He is in robust health, is as bright as a button, and will soon be heard from again in connection with the gas business.

MR. E. A. VAN HORNE has been elected Superintendent of the Oswego (N. Y.) Gas Light Company.

THE proprietors of the Whitehall (N. Y.) Gas Company have leased the old Martin sawmill with the intention of installing therein an electric lighting plant.

THE Wilkes-Barre (Pa.) Council, at a special meeting held to consider the matter of awarding a street lighting contract—mention of earlier action in the premises will be found elsewhere in these columns—rejected the proposition to abandon electric lighting, and substitute gas therefor. A compromise resolution was agreed to under which the city will maintain 49 arc lights, at the rate of \$135 each per annum, and 180 or more gas lamps, to cost \$20 per annum each. This is a reduction of \$4.50 per annum on each electric light from the last contract rate; the gas rate remaining substantially the same. The contract is to run for a year, from first inst.

FROM a Montreal correspondent we have the following: "The annual meeting of the Gas Company was held on the afternoon of the 3d inst., and was largely attended. President Jesse Joseph occupied the chair, flanked by his astute understudy, Manager J. F. Scriver. The reports, which show how prosperous the Company is, were read and accepted, after which Mr. Joseph submitted to the shareholders a proposition to issue \$500,000 of new stock, and a resolution to that effect was unanimously adopted. The stock is to be called at the discretion of the Directors, and quite likely one-half will be emitted now, the other half to be called towards the close of the summer. This issue will bring the company's capital account to \$2,500,000, and the proceeds of the sale of the new stock will go to meet the loans made in improving the property and increasing the plant capacity during the last six years. The most important business, however, that was transacted was an announcement that from and after May first the price of gas was to rule at \$1.40 per 1,000 cubic feet. The retiring Directors were re-elected by acclamation. In conclusion, I might remark that the meeting was a most harmonious one."

"DEAR Journal:—About the most extraordinary thing in connection with current events in New England gas politics is an application for the incorporation of an opposition gas company at Marlboro, Mass., which town is, in all sincerity, just about big enough to enable the present Company to exist. Marlboro's citizens are a not over-liberal set, and I have no doubt that they can tell to a mill just what the value of a penny is. Under the circumstances, then, if the citizens happened to be the only factor in the case, it might be a good thing to advocate the licensing of the opposition company in order that the citizens might be called on eventually to pay the cost of the fight. On the other hand we are confronted with the fact that as the old

Marlboro Company has kept its promises it should be protected. This is where the State Commission will have a chance to show its capacity for protecting invested capital from the attacks of malice; and it is quite an open secret that the opposition attack at Marlboro has its inspiration—well, not from any desire to benefit Marlboro's mill-counters. The putative officers of the new company are: President, Hon. W. N. Davenport; Treasurer, E. L. Bigelow; Clerk, Frank Wall. Another bit of news is that the Springfield Company is likely to lose the lighting of the engine houses. The electricians are willing to do the work for \$800 per annum, as against the Gas Company's charge of \$1,300. The light-of-the-future suppliers say that 20 incandescent lamps of 16-candle power each will amply light each engine house—there are 8 of these in the city—but I am inclined to think that at least 24 lamps of this power would be required to light the houses with anything like a satisfactory result.—OBSERVER."

IT is pretty well understood that General Hickenlooper has so managed it that all the electric lighting enterprises in Cincinnati—save, possibly, the Queen City Company—are under control of the Cincinnati Gas Light and Coke Company. The names of the electric companies absorbed are: The Cincinnati Electric Light Company, the Brush, the Cincinnati Electric Light and Power Company, the Thomson-Houston, the First Edison, and the Edison General Electric Company. It is needless to say that the General dictated the terms.

THE Pottstown (Pa.) Light, Heat and Power Company has been awarded a contract for the public lighting of that place, arc lights to be employed. The contract is to run for three years.

THE Municipal Electric Light Company, which has the contract for the public lighting of St. Louis, expects to begin service under the agreement on or before the 21st.

THE conference committees from the Troy (N. Y.) Gas Company and the Troy Electric Light Company, appointed for the purpose of agreeing, if possible, on a rate or sum for the transfer of the property of the latter to the former, have been unable to solve the problem. It is reasonable to assert, however, that an agreement will finally be reached.

THE authorities of Stockton, Cal., and the local Gas Light and Heat Company have settled their differences in respect to a contract for the public lighting, which is of the electric type. The rate agreed on is \$13.75 per month for each arc burning on moon-table; also, the city to pay 7 cents per hour for each light that is kept burning any time in excess of the hours provided for in the schedule.

OUT of a total of 9,629 meters inspected last year by the Government of Canada, only 198 (or 2 per cent.) were rejected as outside the correct limit in respect to fast measurement. On the other hand, those reported slow were returned at 5.8 per cent.

THE street gamins of New Albany, Ind., have been amusing themselves so greatly of late in smashing the glasses of the gas lamps in that city that Superintendent Dunbar has been obliged to offer a reward that will lead to the conviction of any of the offenders.

MR. W. W. DASHIELL, has resigned from the service of the Bayonne and Greenville (N. J.) Gas Company to accept an important position with an extensive manufacturing establishment in Birmingham, Ala.

IT is likely that the Annapolis (Md.) Gas Company will build a new works.

THE offices of the East Chester (Mt. Vernon, N. Y.) Gas Company have been removed to the Cardner Building, First street and Third avenue.

MAYOR NEMES has signed a 5-year contract with the Atlanta (Ga.) Gas Company under which the latter is to put up and maintain 50 gas street lamps in the suburb known as the "West End."

AT a recent meeting of the Directors of the Bristol (Pa.) Gas Company it was ordered that the price of gas be reduced from \$2 to \$1.60 per 1,000 cubic feet, the new schedule to take effect on May 1st. This looks like business. The Bristol folks will also make a determined effort to popularize the use of gas for cooking.

THE Scranton (Pa.) Gas Company is improving its system of distribution, especially on the Main street division.



A. M. CALLENDER & CO.,
PROPRIETORS.

EDITOR—Jos. R. Thomas, C.E.
ASST. EDITOR—T. J. Cunningham.
MANAGER—C. E. Sanderson.

PUBLISHED ON EACH MONDAY OF THE YEAR AT
No. 42 Pine Street, New York.

This is a recognized official organ of
LIGHT, HEAT, STEAM, WATER SUPPLY,
VENTILATION, SANITARY IMPROVEMENT,
AND GENERAL SCIENCE

TERMS:

Subscription—Three Dollars per annum, in advance. Single copies, 10 cents.

AGENTS.

NEW YORK.—AMERICAN NEWS CO., 39 and 41 Chambers Street.
PHILADELPHIA.—PRATT & Co., Corner Ninth and Arch Streets.
Germany.—B. WESTERMANN & Co., of New York.

MONDAY, APRIL 14, 1890.

Gas Stocks.

Quotations by Geo. W. Close, Broker and Dealer in Gas Stocks.
16 WALL ST., NEW YORK CITY.
APRIL 14.

All communications will receive particular attention.
The following quotations are based on the par value of \$100 per share.

	Capital.	Par.	Bid	Asked
Consolidated.....	\$35,430,000	100	96½	97
Central.....	500,000	50	85	95
“ Scrip.....	220,000	—	95	100
Equitable.....	4,000,000	100	117	119
“ Bonds.....	1,000,000	—	113	115
Harlem, Bonds.....	170,000	—	—	—
Metropolitan, Bonds....	658,000	—	115	120
Mutual.....	3,500,000	100	109	112
“ Bonds.....	1,500,000	—	100	102
Municipal, Bonds.....	750,000	—	—	—
Northern.....	—	50	—	—
“ Bonds.....	150,000	—	—	100
Standard Gas Co—				
Common Stock.....	5,000,000	100	—	45
Preferred.....	5,000,000	100	84	87
Yonkers.....	—	50	112	—
Richmond Co., S. I.	346,000	50	—	—
“ Bonds.....	20,000	—	—	—
Gas Co's of Brooklyn.				
Brooklyn.....	2,000,000	25	109	112
Citizens.....	1,200,000	20	—	68
“ S. F. Bonds....	320,000	1000	100	103
Fulton Municipal.....	3,000,000	100	124	126
“ Bonds....	300,000	—	100	105
Peoples.....	1,000,000	10	80	82
“ Bonds (5's).....	368,000	—	100	—
“ “ (6's).....	94,000	—	100	—
Metropolitan.....	1,000,000	100	96	—
Nassau.....	1,000,000	25	120	—
“ Cfts.....	700,000	1000	100	102
Williamsburgh.....	1,000,000	50	123	125
“ Bonds... ..	1,000,000	—	108	112

Out of Town Gas Companies.

Boston United Gas Co. —				
1st Series S.F. Trust	7,000,000	1000	93	93½
2d “ “ “	3,000,000	1000	71	72
Bay State Gas Co. —				
Stock.....	5,000,000	50	23½	25
Income Bonds.....	2,000,000	1000	—	—
Buffalo Mutual, N. Y. ...	750,000	100	90	95
“ Bonds... ..	200,000	1000	95	100
Citizens, Newark.....	1,000,000	50	155	160
“ “ Bonds.	45,000	—	—	—
Chicago Gas Trust.....	25,000,000	100	45¼	45½
Chicago Gas Light. & Coke Co. —				
G't'd Gold Bonds	7,650,000	1000	93¾	94
Equitable Gas & Fuel Co., Chicago, Bonds	2,000,000	1000	94¾	95½
People's Gas and Coke Co., Chicago—				
1st Mortgage.....	2,100,000	1000	—	100
2d “	2,500,000	1000	96	100
Consumers Gas Light Co., Jersey City.....	2,000,000	100	15	25
Bonds.....	600,000	1000	80	—
Cincinnati G. & C. Co..	6,000,000	100	201	203
Consumers Toronto....	1,000,000	50	190	200
Central, S. F., Cal.....	—	—	80	90
Capital, Sacramento, Cal	—	—	58	—
Consolidated, Balt.....	11,000,000	100	48½	48¾
“ Bonds.....	6,400,000	—	107	107½
Citizens Gas Lt. Co., Rochester, N. Y.....	500,000	—	75	90
Bonds.....	250,000	—	—	—
Hartford, Conn.....	750,000	25	102	108
Jersey City.....	750,000	20	186	190
Laclede Gas Light Co., St. Louis, Mo. —				
Common Stock....	7,500,000	100	12	16
Preferred “	2,500,000	100	—	—
Bonds.....	9,034,400	1000	82	82¾
Louisville, Ky.....	2,570,000	50	125	130
Little Falls, N. Y.....	50,000	100	—	100
“ Bonds	25,000	—	100	103
Montreal, Canada.....	2,000,000	100	200	208
Memphis (Tenn.) Gas... ..	750,000	100	40	—
“ Bonds.	240,000	100	103	—
New Haven, Conn.....	—	25	200	—
Oakland, Cal.....	—	—	35	35½
Peoples, Jersey City... ..	—	—	60	61
“ “ Bonds..	—	—	—	—
Paterson, N. J.....	—	25	99	102
Rochester, N. Y.....	—	50	99	100
Syracuse, N. Y.....	500,000	25	—	—
San Francisco Gas Co.				
San Francisco, Cal....	10,000,000	100	55½	55¾
Washington, D. C.....	2,000,000	20	200	208
Wilmington, Del.	—	50	88	90

Advertisers Index.

	Page
GAS ENGINEERS.	
Jos. R. Thomas, New York City.....	540
Wm. Henry White, New York City.....	543
Wm. Mooney, New York City.....	540
William Gardner, Pittsburgh, Pa.....	540
Fred. Bredel, N. Y. City.....	539
GAS WORKS APPARATUS AND CONSTRUCTION.	
James R. Floyd & Sons, New York City.....	543
Continental Iron Works, Greenpoint, L. I.....	543
Delly & Fowler, Phila., Pa.....	543
Kerr Murray Mfg. Co., Fort Wayne, Ind.....	531
Stacey Mfg. Co., Cincinnati, Ohio.....	543
Bartlett, Hayward & Co., Baltimore, Md.....	541
Morris, Tasker & Co., Limited, Phila., Pa.....	541
Davis & Farnum Mfg. Co., Waltham, Mass.....	531
R. D. Wood & Co., Phila., Pa.....	542
Bouton Foundry Co., Chicago, Ills.....	543
Smith & Sayre Manufacturing Co., New York City.....	542
Fred. Bredel, N. Y. City.....	539
United Gas Improvement Co., Phila., Pa.....	533
National Gas Light and Fuel Co., Chicago, Ills.....	530
Simpkin & Hillyer, Richmond, Va.....	527

GAS AND WATER PIPES.

Gloucester Iron Works, Phila., Pa.....	540
Mellert Foundry and Machine Co., Reading, Pa. (John Fox, Selling Agent, N. Y.).....	540
Ohio Pipe Co., Columbus, Ohio.....	540
M. J. Drummond, New York City.....	540
R. D. Wood & Co., Phila., Pa.....	542
Warren Foundry & Machine Co., New York City.....	540
Donaldson Iron Co., Emaus, Pa.....	540
Dennis Long & Company, Louisville, Ky.....	540

PROCESSES.

National Gas Light and Fuel Co., Chicago, Ills.....	530
Bartlett, Hayward & Co., Baltimore, Md.....	541
Wm. Henry White, N. Y. City.....	543
United Gas Improvement Co., Phila., Pa.....	533
The Fuel Gas and Light Improvement Co., N. Y. City.....	528

INCLINED RETORTS.

Laclede Fire Brick Manuf'g Co., St. Louis, Mo.....	495
--	-----

GASHOLDER TANKS.

W. C. Whyte, New York City..	530
J. P. Whittier, Brooklyn, N. Y.....	535

GASHOLDER PAINT.

The Government Waterproof Paint Co., Boston, Mass.....	528
--	-----

RETORTS AND FIREBRICK.

J. H. Gautier & Co., Jersey City, N. J.....	538
B. Kreischer & Sons, New York City.....	538
Adam Weber, New York City.....	538
Laclede Fire Brick Manuf'g Co., St. Louis, Mo.....	538
Brooklyn Retort and Fire Brick Works, Brooklyn, N. Y.....	538
Borgner & O'Brien, Phila., Pa.....	538
James Gardner, Jr., Pittsburgh, Pa.....	538
Henry Maurer & Son, New York city.....	539
Chicago Retort and Fire Brick Co., Chicago, Ills.....	538
Baltimore Retort and Fire Brick Co., Baltimore.....	538
Oakhill Gas Retort and Fire Brick Co., St. Louis, Mo.....	538
Boston Fire Brick Works, Boston, Mass.....	538

SCRUBBERS AND CONDENSERS.

G. Shepard Page, New York City.....	496
R. D. Wood & Co., Phila., Pa.....	542

REGENERATIVE FURNACES.

Bartlett, Hayward & Co., Baltimore, Md.....	541
Fred. Bredel, New York City.....	539
Chicago Retort and Firebrick Co., Chicago, Ills.....	538
Wm. Henry White, N. Y. City.....	543
J. H. Gautier & Co., Jersey City, N. J.....	539

GAS GOVERNORS.

Connelly & Co., New York City.....	495
Fred. Bredel, N. Y. City.....	539
Friedrich Lux, London, England..	527

SELF-SEALING MOUTHPIECE DOORS.

Smith & Sayre Mfg. Co., New York City.....	542
--	-----

TAR AND CARBONIC ACID EXTRACTOR.

Geo. Shepard Page, N. Y. City.....	532
------------------------------------	-----

CEMENTS.

C. L. Gerould & Co., Brooklyn, N. Y.....	538
--	-----

GAS ENRICHERS.

Standard Oil Co., Cleveland, Ohio.....	544
--	-----

GAS METERS.

John J. Griffin & Co., Phila., Pa.....	546
American Meter Co., New York and Philadelphia.....	547
The Goodwin Gas Stove and Meter Co., Philadelphia, Pa... ..	547
Helme & McIlhenny, Phila., Pa.....	547
D. McDonald & Co. Albany, N. Y.....	547
Nathaniel Tufts, Boston, Mass.....	546
Maryland Meter and Manufacturing Co., Baltimore, Md ...	528
Bell & Jones, Philadelphia, Pa.....	546
Harris Bros. & Co., Philadelphia, Pa.....	546

EXHAUSTERS.

The P. H. & F. M. Roots Co., Connersville, Ind.....	534
Smith & Sayre Manufacturing Co., New York City.....	542
Wilbraham Bros., Philadelphia, Pa.....	535
Connelly & Co., New York City.....	535

GAS COALS.

Penn Gas Coal Co., Phila., Pa.....	545
Perkins & Co., New York City.....	544
Newburgh Orrel Coal Co., Baltimore Md.....	545
Despard Coal Co., Baltimore, Md.....	545
Chesapeake and Ohio R. R. Coal Agency, N. Y. City.....	545
Westmoreland Coal Company, Phila., Pa.....	545
J. & W. Wood, New York City.....	544

CANNEL COALS.

Perkins & Co., New York City.....	544
J. & W. Wood, New York City.....	544

VALVES.

Ludlow Valve Manufacturing Co., Troy, N. Y.....	536
John McLean, New York City.....	536
Chapman Valve Manufacturing Co., Boston, Mass.....	536
R. D. Wood & Co., Phila., Pa.....	542
The P. H. & F. M. Roots Co., Connersville, Ind.....	534

GAS ENGINES.

Schleicher, Schumm & Co., Phila., Pa..... 512
 Clerk Gas Engine Co., Phila., Pa..... 536
 Van Duzen Gas Engine Co., Cincinnati, Ohio..... 536

ENGINES AND BOILERS.

Jarvis Engineering Co., Boston, Mass..... 535
 Ball Engine Co., Erie, Pa..... 528
 Westinghouse Machine Co., Pittsburgh, Pa..... 539

STEAM PUMPS.

Van Duzen & Tift, Cincinnati, Ohio..... 527

GAS LAMPS.

G. Shepard Page, New York City..... 536
 Welsbach Incandescent Gas Light Co., Phila., Pa..... 529
 The Siemens-Lungren Company, Philadelphia, Pa..... 529
 Fiske, Coleman & Company, Boston, Mass..... 538

PURIFIER SCREENS.

John Cabot, New York City..... 536
 Bartlett, Hayward & Co., Baltimore, Md..... 536

GAS STOVES.

American Meter Co., New York and Philadelphia..... 537
 The Goodwin Gas Stove and Meter Co., Phila. Pa..... 548
 George M. Clark & Company, Chicago, Ills..... 529
 D. McDonald & Co., Albany, N. Y..... 547
 Maryland Meter and Manufacturing Co., Baltimore, Md..... 528
 Bell & Jones, Philadelphia, Pa..... 546
 Chicago Gas Stove Company, Chicago, Ills..... 528

STREET LAMPS.

J. G. Miner, Morrisania, New York City..... 491
 Bartlett Street Lamp Man'fg Co., New York City..... 527

BURNERS.

C. A. Gefrorer, Phila., Pa..... 544
 H. W. Rappleye, Philadelphia, Pa..... 368

STEAM BLOWER FOR BURNING BREESE.
 H. E. Parson, New York City..... 500

PURIFYING MATERIAL.

Connelly & Co., New York City..... 535
 Friedrich Lux, London, England..... 527
 Edgewater Lime Works, Edgewater, N. J..... 527

COKE CRUSHER.

C. M. Keller, Columbus, Ind..... 545

ELECTRICAL APPARATUS.

Wm. Henry White, N. Y. City..... 543

BOOKS, ETC.

Gerould's System Gas Bookkeeping..... 528
 1889. Directory. 1889..... 535
 King's Treatise..... 540
 Scientific Books..... 350
 Management of Small Gas Works..... 536
 Gas vs. Electricity..... 528
 Practical Electric Lighting..... 535
 Electric Light Primer..... 535
 American Gas Engineer and Superintendents' Handbook... 455
 Digest of Gas Law..... 527
 Fuel and Its Applications..... 527
 Newbigging's Handbook..... 539

Position Wanted

As Superintendent of Works.

Elther Coal or Water Gas.

Address "B. W.,"

774-4

Care this Journal.

FOR SALE,

The Ironwork for 11 Benches of 5's, viz.:
 Cast Iron Hydraulic Mains, 17 inch diameter, inside.
 Dip Pipes, Bridge Pipes, Staud Pipes.
 Mouthpieces and Lids.
 Four Purifiers, 10 by 16 ft., with 10-inch Connections and dry Center Seal.
 Four Purifiers, 5½ by 10 ft., with 6-inch Connections and Wet Center Seal.
 Valves, 6-inch, 8-inch, and 10-inch.

DAVID MOORE, Treas. Salem Gas Lt. Co.,
 Salem, Mass.

770-tf

POSITION WANTED.

A Mechanical Engineer,

Experienced in Gas Manufacture, wishes a position as Superintendent of a Gas Works. Best of references given and asked. Salary, \$1,200.

"MECHANICAL ENGINEER," care this Journal,
 765-tf or Box 972, West Bay City, Mich.

For Sale, Cheap.

Thirty Benches of 5's, with Cast Iron Hydraulic Main, 5-inch Stand and Dip Pipes, Plugs, etc Also,
 Stays and Rods for Forty Benches, with Door Frames and Doors, Mouthpieces, Lids, Cotter Bars, etc.
 Four Iron 4-Wheel Side-Drop Retort House Coke Wagons. Four Good Coal Carts.
 Twelve Charging Scoops. Hoes, Rakes, and Firing Tools.
 One Set Round Purifiers, 10 ft. diameter, 12-in. Seal, with Wet Center Seal.
 Washers, Scrubbers, and
 One Mackenzie Exhanster, 12-in. openings, 500,000 cu. ft. capacity.
 Will sell whole or in part, to suit purchaser. Address
 772-4 MUNICIPAL GAS CO., Albany, N. Y.

FOR SALE,

The Ironwork for Twelve Benches of 6's, viz.:
 Cast Iron Hydraulic Main.
 7-inch Dip-Pipes, Stand-Pipes, and Bridge-Pipes, complete.
 Floyd Mouthpieces and Self-Sealing Lids, 15x26 in.
 Lids and Mouthpieces only in use over a year. Will be sold cheap.
 ISAAC C. BAXTER,
 772-tf Detroit (Mich.) Gas Lt. Co.

FOR SALE.

A Complete Water Gas Plant.
 60,000 Cu. Ft. Daily Capacity.

Fully equipped; all the latest improvements; includes Generator, Purifiers, and Holder. Can be removed to any part of the country, and set up at small cost. For further information apply to BRADFORD GAS LT. & HEATING CO., Dunkirk, N. Y

Fuel and Its Applications.

By E. J. MILLS, D.Sc. F.R.S., and F. J. ROWAN, C.E., assisted by others, including Mr. F. P. Dewey, of the Smithsonian Inst, Wash., D. C.

7 PLATES, AND 607 OTHER ILLUSTRATIONS. ROYAL OCTAVO, PAGES XX, 802. HANDSOME CLOTH, \$7.50.

A. M. CALLENDER & CO., 42 Pine St., N. Y.

Simpkin & Hillyer

RICHMOND, VA.

MANUFACTURERS OF

Gas Works Apparatus

BENCH CASTINGS, CONDENSERS,
 Scrubbers, Purifiers, Dry Center Seals,
 FOUR-WAY VALVES, GAS VALVES,
 SULPHATE OF AMMONIA APPARATUS,
 TANKS, ENGINES, BOILERS,
 PUMPS, ETC., ETC.

Plans, Specifications and Estimates furnished for new works, or alteration of old works. Correspondence solicited. Works, Newport News, Va.

Bartlett Street Lamp Mfg. Co.

MANUFACTURERS OF

Globe Lamps,

FOR

Streets, Parks, Public Buildings, Railroad Stations, etc.

LAMP POSTS

A Specialty.

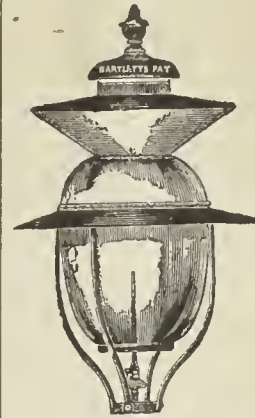

Office and Salesroom,

40 & 42 COLLEGE PLACE, - - N. Y. CITY.

Gas Companies and others intending to erect Lamps and Posts will do well to communicate with us.

FRIEDRICH LUX,

Ludwigshafen am Rhein and London.

Lux Mass

GAS GOVERNORS,

Gas Balance.

EDGEWATER LIME WORKS

Chas. F. McKenna, Proprietor.

SHELL LIME.

Lime by the Cargo for Gas Purification.

EDGEWATER, BERGEN CO., N. J.

Write for Testimonials and Prices.

VAN DUZEN'S STEAMJET PUMP

For MILLS, FACTORIES, SHOPS, ETC.
 For Elevating and Conveying Liquids.
 For Emptying Pits, Sinks, Cesspools, etc., and as a Fire Pump.
 10 Sizes. \$7 to \$75. Every Pump warranted.
 Write for Descriptive Book to VAN DUZEN & TIFT, 106 E. Second St., CINCINNATI, O.

GREENOUGH'S

"DIGEST OF GAS LAW."

Price, \$5.00.

This is a valuable and important work, a copy of which should be in the possession of every gas company in the country, whether large or small. As a book of reference it will be found invaluable. It is the only work of the kind which has ever been published in this country, and is most complete. Handsomely bound. Orders may be sent to

A. M. CALLENDER & CO.,

42 Pine Street, N. Y.

F. D. HARMON, PRES.

CHAS. C. ALLEN, SEC. AND TREAS.

P. W. MACKENZIE, CHIEF ENGR. & SUPT.

THE FUEL GAS AND LIGHT IMPROVEMENT CO.

OF AMERICA.

Owner of the Mackenzie Patents of Dec. 31, 1889,
For the United States, England, Russia, France, Germany, Austria, and Canada,

No. 32 Park Place, New York City.

This SYSTEM is an ABSOLUTELY NEW DEPARTURE IN THE MANUFACTURE OF FUEL AND ILLUMINATING GAS. The COST OF GAS IN THE HOLDER by our System is at least THIRTY PER CENT. LESS than that made by any other process of the day. The Gas contains neither SULPHUR nor other impurities, nor is there any resultant LAMPBLACK OR TAR RESIDUUM. The Gas is manufactured WHOLLY from LIQUID HYDROCARBONS, such as Lima, Penn. Crude, and Fuel Oils, Naphtha, etc. Neither PERISHABLE PIPES nor other RETORTS, NOR THEIR EQUIVALENTS, are used. The Gas requires NO PURIFICATION. Neither COAL, COKE, nor any other HARD CARBONS enter into the manufacture or composition of the Gas, thereby requiring LESS LABOR THAN ANY OTHER METHOD. The APPARATUS is extremely SIMPLE, SUBSTANTIAL, and DURABLE. Works under our system can be CONTINUOUS or ALTERNATING. If alternating, the Nitrogen present will be less than 4½ per cent. If continuous, the limited amount of Nitrogen present is neutralized by Carbon. One gallon of Lima oil by our process EQUALS ALL THE COAL required for making 1,000 feet of carbureted Water Gas.

CHARLES E. DICKEY.

JAMES B. SMALLWOOD.

CHARLES H. DICKEY.

THE MARYLAND METER AND MANUFACTURING CO.

Established 1866.

BALTIMORE, North & Saratoga Sts.

CHICAGO, 197 Michigan Street.

NEW YORK, 766 Broadway.

BOSTON, 4 Central Street.

ST. LOUIS, 1115 Olive Street.

SAN FRANCISCO, 330 Pine Street.

CONSUMERS' & STATION METERS, PRESSURE GAUGES, Etc., Etc.
"Success" and "Perfect" Gas Stoves.

BALL AUTOMATIC
CUT OFF ENGINE
MADE ONLY
BY
THE BALL ENGINE CO
ERIE PA.

GEROULD'S

System Gas Bookkeeping.

Approved and adopted by many of the prominent Gas Engineers of the Country.

Sample Sheets and Price-List furnished free on application to

L. P. GEROULD, - - Mendota, Ill.

GAS vs. ELECTRIC LIGHT.

We would invite attention to the able and exhaustive argument of General A. Hickenlooper, President of the Cincinnati Gas Light and Coke Company, contained in a handsome pamphlet of 96 pages, entitled

"EDISON'S INCANDESCENT ELECTRIC LIGHTS FOR STREET ILLUMINATION. REPORT OF AN ARGUMENT DELIVERED BY A. HICKENLOOPER BEFORE THE COMMITTEE ON LIGHT, MUNICIPAL COUNCIL, CITY OF CINCINNATI, JULY 22, 1886."

This is a subject of special interest to all Gas Light Companies.

Prices.

25 copies.....	\$7.50	100 copies.....	\$22.50
50 copies.....	12.50	250 copies.....	50.00

A sample copy will be sent by mail on receipt of 50 cts.

A. M. CALLENDER, & CO., 42 PINE ST., N. Y. CITY

GASHOLDER PAINT.

Use Only

THE GOVERNMENT WATERPROOF PAINT.

Proof against Ammonia, and Absolutely Waterproof. Send for Prices and Particulars.

THE GOVERNMENT WATERPROOF PAINT CO., 122 Milk Street, Boston, Mass.

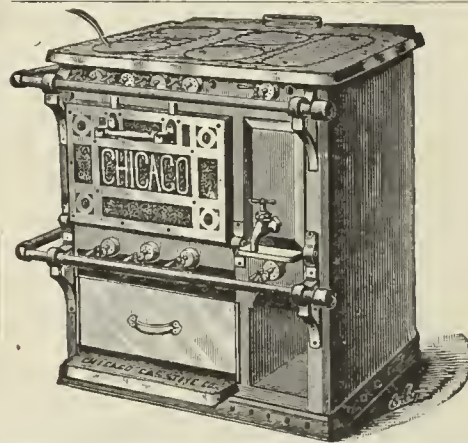

CHICAGO GAS STOVE CO.

MANUFACTURERS OF ALL KINDS OF

Gas Cooking and Heating
APPLIANCES.

117-119 Lake St., CHICAGO.

Send for Catalogue.

PATENTS.

FRANKLIN H. HOUGH

Solicitor of American & Foreign Patents.

925 F. ST., WASHINGTON, D. C.

(NEAR U. S. PATENT OFFICE.)

Personal attention given to the preparation and prosecution of applications for Letters Patent. All business before the U. S. Patent Office attended to for moderate fees. **No Agency in the United States possesses superior facilities for obtaining Patents**, or for ascertaining the patentability of inventions. Copies of patents furnished for 25 cents each. Correspondence solicited.

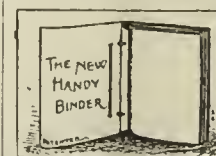

THE NEW HANDY BINDER.

This article may be described as elegant in appearance, strong, durable, and possessing many special qualities of its own. It allows the opening of the pages perfectly flat, whether one or several numbers are in the binder. Any number can be taken out and replaced without disturbing the others. The papers are not mutilated for subsequent binding in permanent form. The binder is supplied with gilt side title, and is an ornament to any desk or reading table. The JOURNAL, filed in the Handy Binder, becomes a volume of great value, always convenient for instant reference. **Handy Binder, Postage paid, \$1.00.**

A. M. CALLENDER & CO., 42 Pine St., N. Y.

The Gordon Portico Lamp.

A successful Competitor of the Arc Electric Light for lighting Store Fronts, Show Windows, Depots, Railway Sheds, etc., etc.

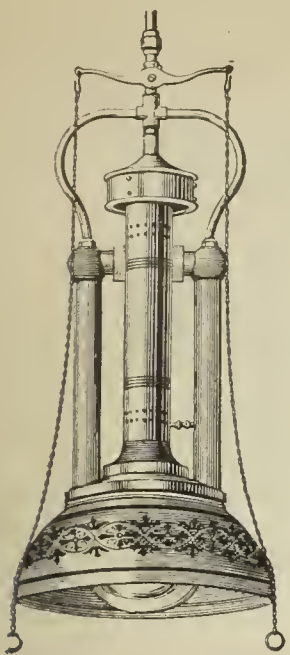

Gordon Portico Lamp.

The Gordon Street Lamp.

A Successful Competitor of the Arc Electric Light for lighting Streets, etc., etc.

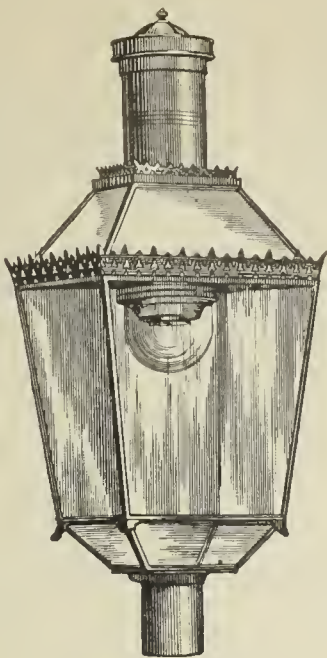

Gordon Street Lamp.

The Lungren Lamp.

A Successful Competitor of the Incandescent Electric Light for Interiors, etc. Is especially applicable for the lighting of Offices, Stores, Factories, Mills, Show Windows, Libraries, and all situations where an increased illumination is desired.

More than 25,000 Lungren Lamps are now in use. Testimonials, references, or any desired information will be cheerfully given.

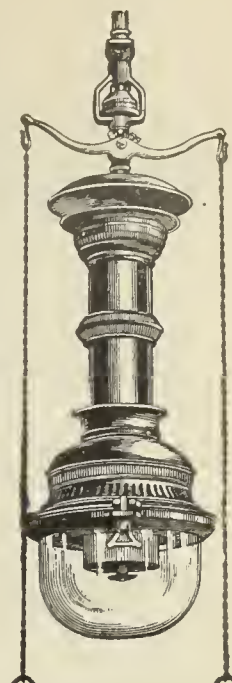

Lungren Lamp.

THE SIEMENS-LUNGREN CO., N.E. Cor. 21st St. & Washington Av., PHILADELPHIA.

WELSBACH SYSTEM OF Incandescent Gas Lighting.

OFFICE, DREXEL BUILDING, PHILA., PA.

At the Fall Session of the Board of Supervisors of Winnebago County, held at the County Court House, Oshkosh, Wis., Nov. 26, 1889, the report submitted by Mr. C. W. Cook, Chairman of the Committee on Public Buildings, recommending the use of the Welsbach Incandescent Gas Burner in the Buildings under their charge, was unanimously adopted, because of the extreme economy in the consumption of Gas and the superior character of the light obtained.

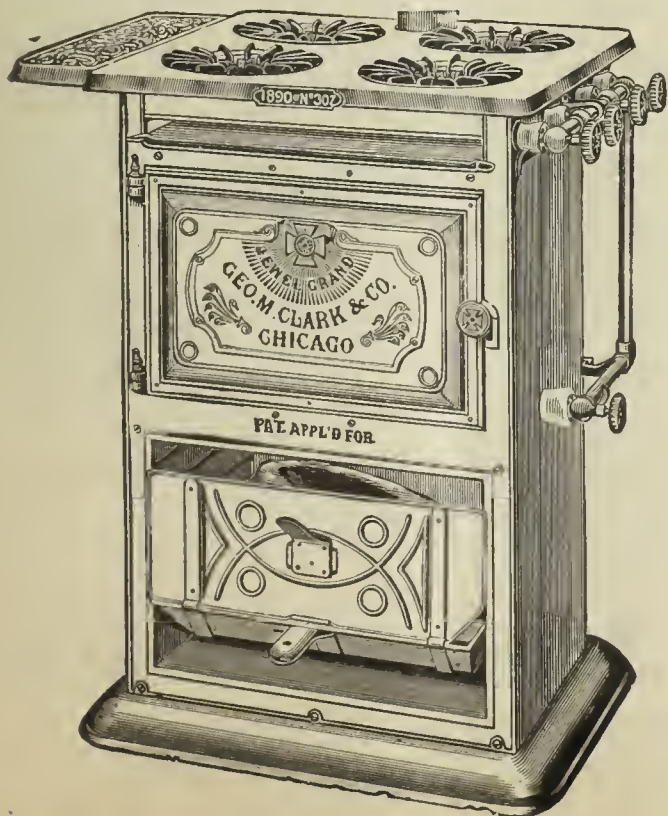

JEWEL GAS STOVES

MANUFACTURED BY

GEORGE M. CLARK & COMPANY.

Nos. 157 & 159 Superior Street, - - - Chicago, Ill.

EVERY CONCEIVABLE SIZE AND STYLE,

Ranging in Prices from \$1.50 to \$30.00.

WE USE NO GAS COCKS.

All Flames are Regulated by a Direct Needle Valve.

The JEWEL

IS THE

Only Well-Made Gas Stove on the Market.

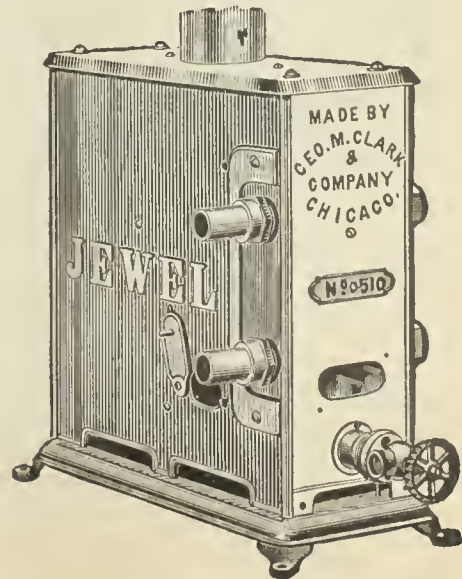

Write for our 1890 Catalogue and see for yourself.

NATIONAL GAS LIGHT AND FUEL CO.,

218 La Salle Street, Chicago.

C. D. HAUKE, Prest. & Gen'l Manager.

A. W. GREEN, Vice-Prest.

N. A. McCLARY, Sec. & Treas.

E. E. MORRELL, Engr.

GAS WORKS

Built, Remodeled, Leased, and Purchased.

71 Springer Cupolas
have been installed
in the U. S. during
the past four years.

The total capacity of
Springer Apparatus
now in use is over
25,000,000 ft. daily.

THE SPRINGER CUPOLA SYSTEM

Has Proven Itself the most Economical and Satisfactory Method of Gas Manufacture ever brought to the attention of the Gas Fraternity.

GUARANTEED ESTIMATES of Cost of Gas Furnished on Application.

GASHOLDER TANK CONSTRUCTION, ETC.

Gas Companies and others about to erect Gasholders will find it profitable to consult W. C. Whyte, who for over 30 years has made a specialty of

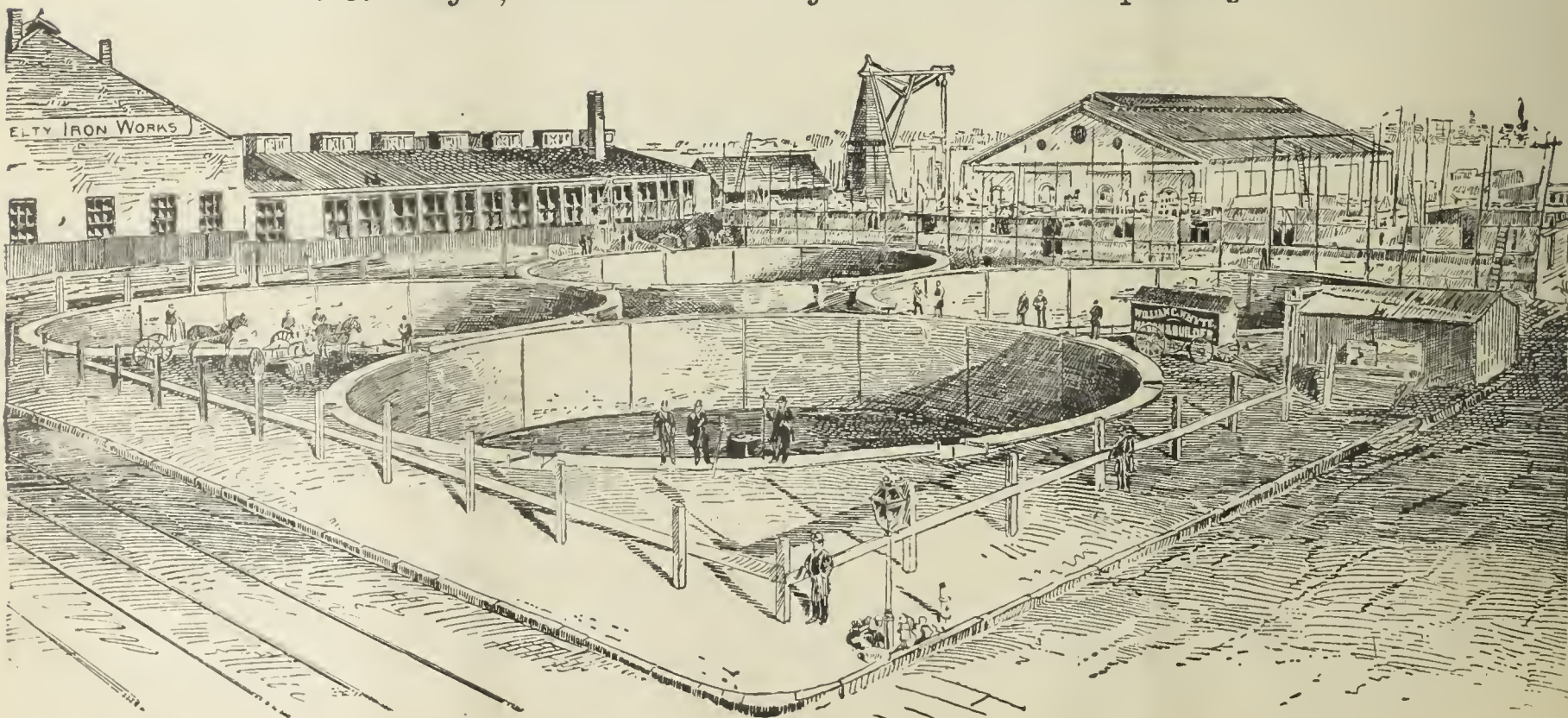

Tank Excavation and Mason Work.

Fifty Tanks now in operation show the sort of work done. Address

W. C. WHYTE, - No. 15 Cortlandt Street, N. Y. City.

THIS SPACE
WILL BE
Occupied Next Month by the
KERR MURRAY MFG. CO.
FORT WAYNE, IND.
**GAS WORKS
APPARATUS
AND
HOLDERS.**

**DAVIS & FARNUM MFG. CO.,
WALTHAM, MASS.**

PRINCIPAL OFFICE AND WORKS, Waltham, Mass.

BOSTON OFFICE, Room 55, Mason Building, 70 Kilby Street.

SINGLE, DOUBLE,
AND
TRIPLE LIFT
Gas holders.
OF ANY CAPACITY.

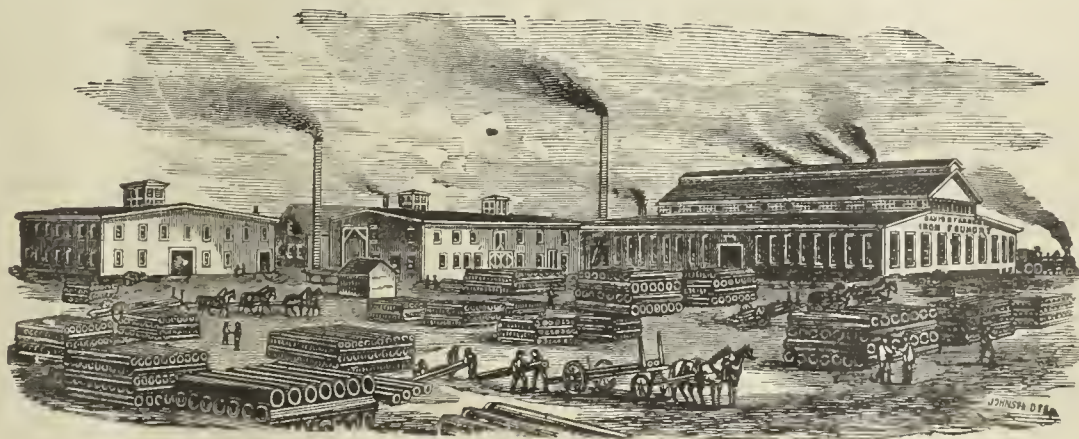

TUBULAR, PIPE,
AND
SINUOUS FRICTION
Condensers.
OF ALL SIZES.

IRON ROOF FRAMES AND FLOORS.
Purifying Boxes, Center Seal or Valve Connections, Bench Work.
Reversible Lime Trays.
SELF-SEALING AND PRESSED STEEL MOUTHPIECE LIDS.
Coke Barrows, Coal Wagons, and all Apparatus Requisite for a Complete Gas Plant.
— ALSO —
Gas and Water Pipe, Flanged Pipe,
Sugar House Work, and Special Castings of all Descriptions.

THE WALKER TAR AND CARBONIC ACID EXTRACTOR.

A very general demand exists, in both large and small Gas Works, for an apparatus that will be absolutely efficient in the removal of the tar which passes the hydraulic main and condenser. Many attempts have been made to accomplish this, but, I believe, without success, until the introduction, five years ago, in England, of the C. & W. Walker Patent Tar and Carbonic Acid Extractor. During these years this apparatus has been adopted by many of the most prominent Engineers, not only in England, but also on the Continent of Europe and in other parts of the world. It is only necessary to give here a partial list in order to convince any intelligent American Gas Engineer that this machine must have succeeded fully in accomplishing the desired results.

The following Engineers have personally given permission to refer to them:

G. C. Trewby, Esq., Engineer-in-Chief of the Gas Light and Coke Co., London. The manufacturing plant at Beckton is built in complete sections of 3,000,000 cubic feet capacity each. A Walker Tar Extractor has been fitted to each one of these sections. This was done after a long and thorough trial on one of its sections. The Tar Extractor has been supplied to other works of the Gas Light and Coke Co., including those of which John Methven, Engineer of the Gas Light and Coke Co. at the Nine Elms Station, is in charge. Also to G. E. Stevenson, Peterborough Gas Works; B. Green, Mitcham and Wimbledon Gas Works; W. H. Smith, Bedford Gas Works; F. Linging, Norwich Gas Works; J. T. Browning, Colchester Gas Works; S. B. Darwin, Portsmouth Gas Works; J. McCrae, Dundee Gas Works; W. J. Wells, Stamford Gas Works; J. M. Darwin, Longton Gas Works; J. Paterson, Warrington Gas Works; and J. Coulter, of the Dundalk Gas Works. All of the foregoing gas works are located in Great Britain.

Mr. Charles A. Gerdenier, Superintendent of the Bridgeport (Conn.) Gas Light Company, writes as follows, under date of Dec. 3, 1887:

"The C. & W. Walker Tar and Carbonic Acid Extractor has been in operation at these works for the past six weeks, and is an unqualified success. It removes every particle of Tar from the gas in once passing through the apparatus, and a large percentage of the Carbonic Acid. I also feel quite sure that it prevents the formation and deposit of Naphthaline, because since I started the Washer I have had no stoppages from this cause. These works have been seriously troubled with Tar for many years, and I have used several kinds of apparatus and every expedient which has come to my attention for dealing with the difficulty, but without success. The Walker apparatus occupies comparatively small space, is less expensive than other systems, and requires but little attention. I carry 2½-inch seal, and have an automatic tar delivery valve. This Tar Extractor is indispensable to gas makers."

I have taken the Agency for the United States for this apparatus, and am now prepared to make contracts to erect it on the premises of any Gas Company. It would be manufactured in the following sizes:

No. 1,	50,000 to	100,000	cu. ft. per	24 hrs.,	3 ft. square,	5 ft. deep.			
No. 2,	"	125,000	"	"	4 "	"	"	"	"
No. 3,	"	250,000	"	"	5 "	"	"	"	"
No. 4,	"	500,000	"	"	6 "	"	"	"	"
No. 5,	"	750,000	"	"	7 "	"	"	"	"
No. 6,	"	1,000,000	"	"	8 "	"	"	"	"
No. 7,	"	1,250,000	"	"	9 "	"	"	"	"
No. 8,	"	1,500,000	"	"	10 "	"	"	"	"
No. 9,	"	2,000,000	"	"	12 "	"	"	"	"
No. 10,	"	3,000,000	"	"	15 "	"	"	"	"

This Tar Extractor will perform its work with about one-fourth the usual back-pressure heretofore required. It is simple in construction, and can be supplied at a very reasonable price—less than any other ever before introduced. Satisfactory results will be guaranteed in every instance.

GEO. SHEPARD PAGE,

SOLE AGENT FOR THE UNITED STATES,

No. 69 Wall Street, - - - New York.

THE UNITED GAS IMPROVEMENT CO.

Drexel Building,

CHESTNUT AND FIFTH STREETS,

PHILADELPHIA, PA.

OFFICERS:

WILLIAM W. GIBBS, President.

GEORGE PHILLER, Vice-President.

SAM'L T. BODINE, Gen'l Manager.

RANDAL MORGAN, Gen'l Counsel.

EDWARD C. LEE, Sec'y and Treas.

ALEX. C. HUMPHREYS, Gen'l Supt.

WALTON CLARK, Ass't Gen'l Supt.

H. H. EDGERTON, Chem. and Eng'r.

DIRECTORS:

GEORGE PHILLER,

THOMAS DOLAN,

HENRY C. GIBSON,

WM. T. CARTER,

WILLIAM G. WARDEN,

SAM'L T. BODINE.

BUILDERS, LESSEES AND PURCHASERS OF

✻ GAS WORKS. ✻

ROOTS' GAS AND BYE-PASS VALVES.

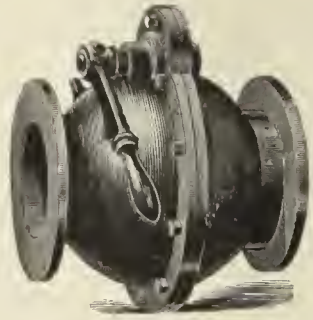

GAS VALVE

Quick Acting,
Simple,
Efficient, Durable.



BYE-PASS VALVE.

Automatic Action,
Reliable
Simple, Durable.

Thousands now in use and giving perfect satisfaction. Write for Catalogue and Prices.

ROOTS' NEW GAS EXHAUSTER.

Unsurpassed
for Neatness
of Design,
Durability,
Simplicity,
Efficiency,
and Economy
of Power.

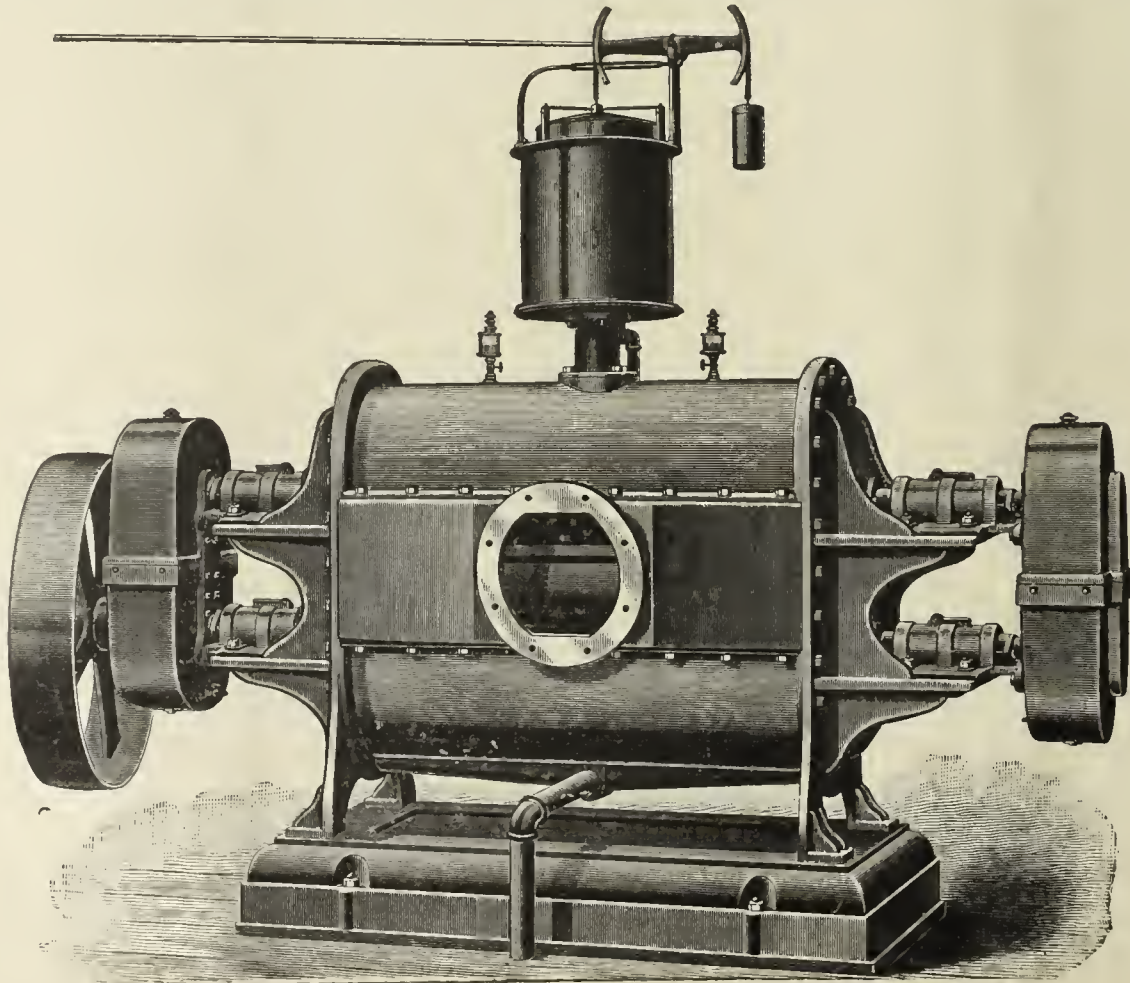

All Parts
Requiring
Attention
are External
and Easily
Accessible
at all Times.

Send for Descriptive Catalogue and Price List.

THE P. H. & F. M. ROOTS CO., Patentees and Manufacturers, **CONNERSVILLE, IND.**

S. S. TOWNSEND, Gen. Agt., 22 Cortlandt St., N. Y.

COOKE & CO., Selling Agts., 22 Cortlandt St., N. Y.

CONNELLY & CO.,

SOLE MANUFACTURERS OF THEIR PATENTED SPECIALTIES.

"IRON SPONGE." Saves money, saves labor, and is the most efficient purifying agent ever offered as a substitute for lime. Now used in every State in the Union, and purifying daily over thirty-five million cubic feet. Should be used in every gas works. Its own saving will pay for it many times over.

AUTOMATIC GOVERNOR. Has been on the market but three years, and in that time has been introduced more generally than any invention ever designed for use in gas works. Over two hundred of them now in use. Sensitive; reliable; perfectly automatic; reduces leakage; satisfies consumers, and gives great relief to the Manager. No gas works is complete without one of these machines.

STEAM JET EXHAUSTER. Designed particularly for small works. Combines Exhaust Tube, Steam Governor Gas Compensator, and Bye-Pass Valves in the most compact form possible; occupies but little space; uses very little steam; operated by ordinary workmen; saves formation of carbon in retorts; increases yield 10 to 15 per cent. Specially adapted for mixing air with oil gas. No works too small to use them profitably.

Prices given on all our specialties delivered at any point in the United States. Correspondence solicited.

CONNELLY & CO., No. 111 Broadway, New York City.

WILBRAHAM GAS EXHAUSTER & ENGINE COMBINED.

WILBRAHAM BROS.,
PHILADELPHIA, PA.

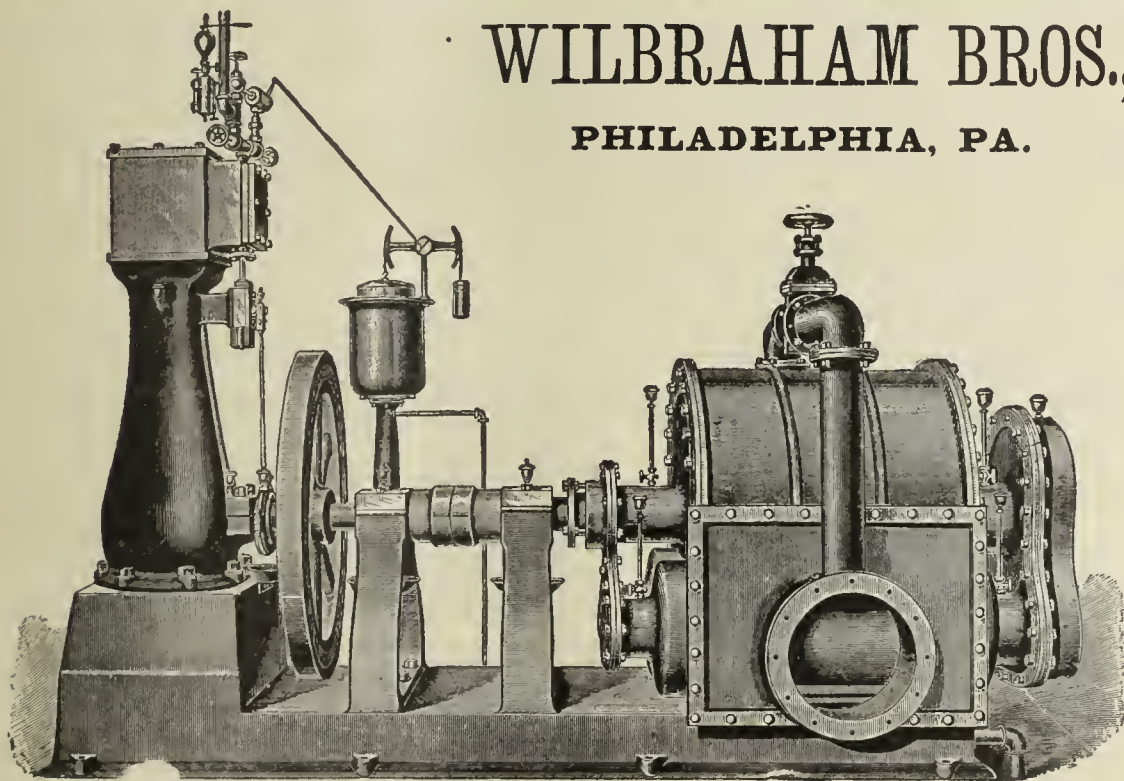

JARVIS ENGINEERING CO.,

61 Oliver St., Boston, Mass.

CONTRACTORS FOR ERECTING

COMPLETE STEAM OUTFITS FOR ELECTRIC LIGHTING STATIONS.

Steel Boilers set with Jarvis Pat. Boiler Setting

To burn **COKE SCREENINGS** for Fuel.

ARMINGTON & SIMS CO. ENGINES,

Belting direct to Dynamos, without using Shafting.

SEND FOR CIRCULARS.

REFERENCES.—Charlestown Gas & Electric Light Co., Charlestown, Mass.; Schenectady Gas & Electric Light Co., Schenectady N. Y.; Brookline Gas Co., Brookline, Mass.

Practical Electric Lighting

By A. BROMLEY HOLMES, A.M.I.C.E.

With 87 Illustrations. Third Edition. Price, \$1.00.

Electric Light Primer.

By CHARLES L. LEVEY.

A simple and comprehensive Digest of all the most important facts connected with the running of the Dynamo and Electric Lights, with Precautions for Safety, etc.

Price, 50 cents.

A. M. CALLENDER & CO., 42 Pine St., N. Y.

Gasholder Tanks & Gas Works Masonry Complete.

PLANS PREPARED AND ESTIMATES FURNISHED AT SHORT NOTICE.

J. P. WHITTIER, - - 499 Wythe Av., Brooklyn, N. Y.

1889 DIRECTORY 1889

OF THE GAS LIGHT COMPANIES of the UNITED STATES & CANADA.

Price, \$3.00.

A. M. CALLENDER & CO., No. 42 Pine Street, N. Y. City.



CHAPMAN VALVE MANUFACTURING CO.,

MANUFACTURERS OF

Valves and Gates for Gas, Ammonia, Water, Etc.

Also, Gate Fire Hydrants With and Without Independent Nozzle Valve. All Work Guaranteed.

WORKS & GEN'L OFFICE:
Indian Orchard, Mass.

TREASURER'S OFFICE:
72 Kilby & 112 Milk Sts, Boston, Mass.

LUDLOW VALVE MFG. CO.



OFFICE AND WORKS,

938 to 954 River Street and 67 to 83 Vail Av.,
TROY, N. Y.

GEO. SHEPARD PAGE,

No. 69 Wall Street, N. Y. City.

REPRESENTING

THE BOWER GAS LAMP.

C. & W. Walker's Carbonic Acid & Tar Extracting Washer

B. DONKIN & CO.'S PAT. IMP. GAS VALVE.

Young & Beilby's Patents. Henry Aitkin's Patents.

R. P. SPICE, London, Eng. HENRY SIMON, Manchester, Eng.

MILLS' REVERSIBLE LIME TRAY,

AND

WOODWORK

Of Every Description

NEEDED BY GAS WORKS.

SEND FOR CIRCULAR AND PRICE LIST TO

BARTLETT, HAYWARD & CO.,

Pratt and Scott Streets, Baltimore, Md.

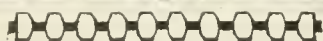
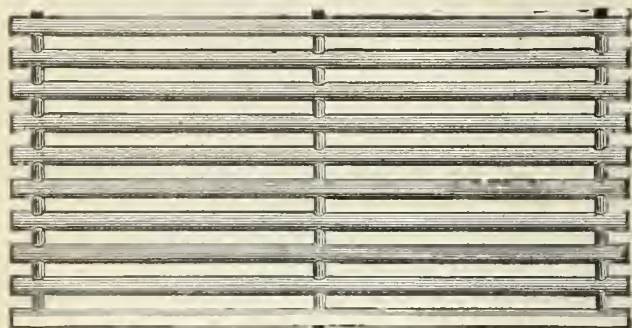

VAN DUZEN GAS & GASOLINE ENGINE

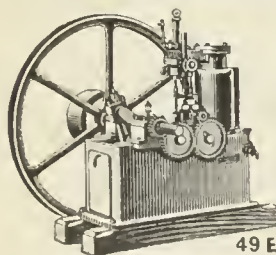

OPERATED with COAL and OTHER MANUFACTURED GASES AND GASOLINE.

RELIABLE AND ECONOMICAL.

Fully Warranted

VAN DUZEN

Gas & Gasoline Engine Co.

49 E. 2d St., Cincinnati, O.

A. MacKinnon Machine Co., Agts., 22 Warren St., N.Y.

The Management of Small Gas Works.

BY C. J. R. HUMPHREYS.

Price, \$1.

Orders to be sent to **A. M. CALLENDER & CO.,**

42 PINE STREET, NEW YORK.

Hydraulic Main Dip Regulators, also Check Valves, Foot Valves, Yard-wash and Fire Hydrants. Send for Circulars.

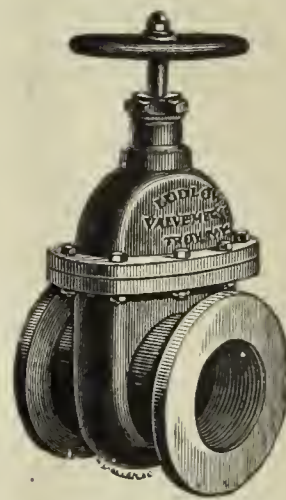

Valves.—Double and Single Gate, 1/2 in. to 48 in., outside and inside Screws. Indicator, etc., for Gas, Water, Steam, and Oil. Send for Circulars.

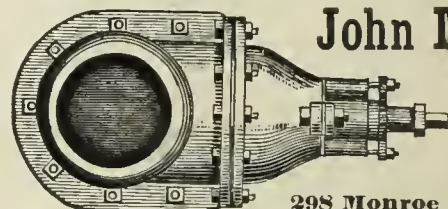

John McLean

Man'facturer

GAS VALVES.

298 Monroe Street, N. Y.

SPECIAL TRAYS FOR IRON SPONGE OR OXIDE OF IRON. CHURCH'S TRAYS A SPECIALTY.

REVERSIBLE—STRONGEST—MOST DURABLE—MOST EASILY REPAIRED.



306-310 ELEVENTH AVENUE, NEW YORK.

WE ALSO MAKE THE CHEAPEST AND STRONGEST REVERSIBLE BOLTED TRAYS IN THE MARKET.

THE CLERK GAS ENGINE CO.,

Main Office, 1012, 1014, 1016, 1018 Filbert St., Philadelphia, Pa.

WM. W. GOODWIN, Prest.

E. STEIN, Sec.

S. LEWIS JONES, Asst. Sec.

A. J. DOTY, Supt.

The utility and convenience of the Gas Engine being no longer an open question, it only remains now for intending purchasers to select the BEST. We claim for the CLERK GAS ENGINE that it is equal to any other manufactured as regards steadiness in running, simplicity, and ease of keeping in repair, and that it gives the greatest amount of power for the least money (both in first cost and expense of running) of any engine made. In support of this claim we refer to the test of the Gas Engines made under the direction of the American Institute of New York, in December, 1885, and heretofore published in these columns. These engines are especially adapted for continuous running under heavy loads, and we can refer to Engines which have run 22 hours a day for months at a time

Made in Sizes of 5 10 15 20, and 25 Horse Power. All Engines Guaranteed for One Year.

GAS STOVES.

GAS METERS.

GAS STOVES.

THE AMERICAN METER CO.,

MANUFACTURERS OF

GAS METERS, Station Meters,

METER PROVERS, PHOTOMETERS,

PRESSURE GAUGES OF ALL KINDS,

AND



Standard 3 Diaphragm Dry Meter



Standard 2 Diaphragm Dry Meter.

Apparatus for Testing the Quantity and Quality of Gases.

GAS STOVES FOR HEATING AND COOKING

Sole Agents in the United States for

Verity's Patent Gas Fires.

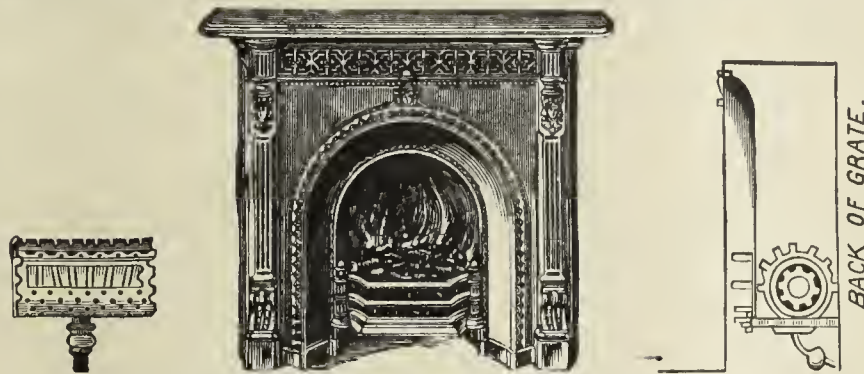

Circulars and Price Lists on Application.

MANUFACTORIES,

508 to 514 West Twenty-second St., N. Y.

Arch and Twenty-second St., Phila.

Nos. 244 & 246 North Wells Street, Chicago, Ill.

AGENCIES,

No. 177 Elm Street, Cincinnati, Ohio.

No. 222 Sutter Street, San Francisco, Cal.

No. 810 North Second Street, St. Louis, Mo.

GAS STOVE SHOW ROOMS, No. 242 Sixth Avenue, New York City.

RETORTS AND FIRE BRICK.

RETORTS AND FIRE BRICK.

RETORTS AND FIRE BRICK.

J. H. GAUTIER & CO.,CORNER OF
GREENE AND ESSEX STREETS,
JERSEY CITY, N. J.

MANUFACTURERS OF

**Clay Gas Retorts,
Gas House Tiles,
Fire Bricks, Etc. Etc.**Ground Clay, Fire Brick and
Fire Sand in Barrels,

J. H. GAUTIER. C. E. GREGORY. C. E. GAUTIER.

BROOKLYN**Clay Retort & Fire Brick Works,**
(EDWARD D. WHITE & CO.)Manufacturers of Clay Retorts, Fire Brick,
Gas House and other Tile.VAN DYKE, ELIZABETH, RICHARDS & PARTITION STS.
Office, 88 Van Dyke St., Brooklyn, N. Y.**LACLEDE FIRE BRICK MFG. CO.,**

MANUFACTURERS OF

Fire Brick, Gas Retorts,

AND

ST. LOUIS STANDARD SEWER PIPE.Blast Furnace and Cupola Linings, every description of Fire
Clay Material, Fire Clay Flue Linings, Chimney Tops
Dry Milled and Crude Fire Clays, etc.

OFFICE AND DEPOT

901, 903, and 905 Pine Street,
ST. LOUIS, MO.

ESTABLISHED IN 1845.

B. KREISCHER & SONS,

OFFICE FOOT OF HOUSTON ST., E. R., N. Y.

Gas Retorts,**TILES, FIRE BRICK.**

AND EVERYTHING IN THE FIRE CLAY LINE.

MANHATTAN

FIRE BRICK & ENAMELLED CLAY

RETORT WORKS**ADAM WEBER.****CLAY GAS RETORTS**

AND RETORT SETTINGS

FIRE BRICKS, TILES, ETC.,

Office and Works, 15th Street and Avenue C., N. Y.

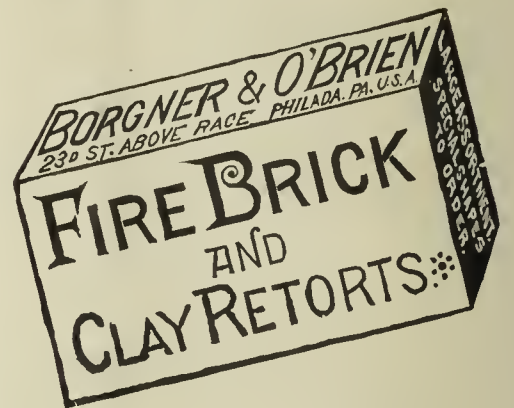
Works,
LOCKPORT STATION, PA.

—ESTABLISHED 1864.—

JAMES GARDNER, JR.,

Successor to WILLIAM GARDNER & SON.

Fire Clay Goods for Gas Works.

H. A. NORTON, No. 4 CENTRAL STREET, BOSTON, MASS., Agent for the New England States.

GEO. C. HICKS, CHICAGO CHAS. A. REED,
Prest. Sec. & Treas.**Retort and Fire Brick Co.,**

MANUFACTURERS OF

Fire Clay Goods of all Kinds,

AND BEST QUALITY ONLY.

Regenerative Furnaces & Water Gas Goods.

45th St., Clark to La Salle, Chicago.

GEROULD'S IMPROVED RETORT CEMENT.A Cement for patching retorts, putting on mouthpieces, and
making up all bench-work joints. This Cement is mixed ready
or use. Economic and thorough in its work. Fully warranted
o stick. For recommendations and price list address**C. L. GEROULD & CO.,**

5 & 7 Skillman St., Brooklyn, N. Y.

Western Agent, H. T. GEROULD, Mendota, Ill.

**Parker-Russell
Mining and Mfg. Co.,**

CITY OFFICE,

Mermod-Jaccard Bldg., Rooms 307 & 308,
Broadway & Locust St., St. Louis. Mo.

PROPRIETORS OF THE

OAKHILL GAS RETORT & FIRE BRICK W'KSOur immense establishment is now employed almost entirely in
the manufacture of**Materials for Gas Companies**We have studied and perfected three important points. Our re-
torts are made to stand changes of temperature, the strongest
heats of the furnace, and the abrasion of feeding and emptying.
We have the exclusive Agency for the West of the celebrated**Kloenne-Bredel Full Depth and
Semi-Recuperator Benches,**

And also furnish and build

Our Own Styles Semi-Recuperator Furnaces
for the use of Coal or Coke as fuel.

THOS. SMITH, Prest. AUGUST LAMBLA, Vice-Prest. & Supt.

BALTIMORE**RETORT & FIRE BRICK CO.**

MANUFACTORY AT

LOCUST POINT, BALTIMORE, MD.

Clay Retorts, Blocks & Tiles**FIRE BRICK, FIRE CLAY,
AND FIRE CEMENT.**Red and Buff Ornamental Tiles and Chim-
ney Tops. Drain and Sewer Pipe (from
2 to 30 inches). Baker Oven Tiles
12 x 12 x 2 and 10 x 10 x 2.

WALDO BROS., 88 WATER ST., BOSTON, MASS

Sole Agents the New England States.

Boston Fire Brick Works Manufacturers of **Gas Retorts and Settings**

Under the Personal Supervision of MR. GEO. C. HICKS late of Chicago.

Fire Clay Goods of all kinds. Akron Sewer Pipe, Lime, Cement, etc. Agts. for the Arc Gas Lamp & Governing Gas Burners.

Send for Circulars and Prices to

FISKE, COLEMAN & CO., Managers, No. 62 Congress Street, Boston, Mass.

HENRY MAURER & SON,

(ESTABLISHED 1856.)

EXCELSIOR FIRE BRICK & CLAY RETORT WORKS

WORKS, Perth Amboy, N. J.

OFFICE, 418 to 422 East 23d St., N. Y.

Clay Gas Retorts,
BENCH SETTINGS,
Fire Brick, Tiles, Etc.

FLEMMING'S Generator-Gas Furnace

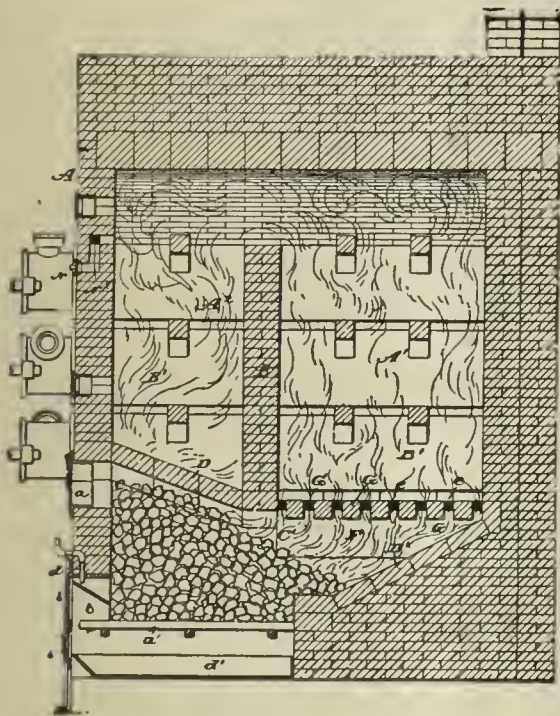

Materials furnished and Benches erected by

J. H. GAUTIER & CO., - Jersey City, N. J.

Address as above, or D. D. FLEMMING, Jersey City, N. J.

FRED. BREDEL,

CONTRACTOR FOR THE COMPLETE

Erection and Equipment of Gas Works.

SOLE PROPRIETOR OF THE

KLOENNE PATENTS

FOR NORTH AMERICA.

REGENERATIVE FURNACES.

(900 Retorts are now fired in America by the Kloenne-Bredel System.)

SELF-SEALING MOUTHPIECES.

(Over 800 Now in Use.)

Standard Condensers. Washer-Scrubbers.

TAR WASHERS FOR WATER GAS PLANTS.

(In use in the works of the Chicago Gas Lt. Co.)

GASHOLDERS.

Bredel's Automatic Gas Governor.

Refers, by permission, to Mr. Eugene Vanderpool, Newark, N. J.; Mr E. G. Cowdery, Milwaukee, Wis.; and Mr. Theo. Forstall, Chicago, Ills. For further information, address

FRED. BREDEL,

No. 208 East Seventeenth Street, N. Y. City.

<p>COMPOUND Condensing or Non-Condensing. 16 SIZES, 5 to 500 H. P. Not yet equaled by any form of Engine for HIGH FUEL DUTY AND SIMPLICITY.</p> <p>STANDARD 13 Sizes in Stock. 5 to 250 H. P. 3000 in use in all parts of the Civilized World.</p> <p>JUNIOR 6 Sizes in Stock, 5 to 50 H. P. An Automatic Engine cheaper than a Slide Valve. WELL BUILT. ECONOMICAL. RELIABLE. Over 300 Sold the First Year.</p> <p>All the above built strictly to Gauge with INTERCHANGEABLE PARTS. REPAIRS CARRIED IN STOCK. SEND FOR ILLUSTRATED CATALOGUES.</p>	<p>WESTINGHOUSE ENGINES The Westinghouse Machine Co. PITTSBURGH, PA. U.S.A.</p>	<p>SELLING DEPARTMENT IN THE UNITED STATES.</p> <table border="0"> <tr> <td>New York,</td> <td>17 Cortlandt St.</td> <td rowspan="3">} Westinghouse, Church, Kerr & Co.</td> </tr> <tr> <td>Boston,</td> <td>Hathaway Building,</td> </tr> <tr> <td>Pittsburgh,</td> <td>Westinghouse Build'g,</td> </tr> <tr> <td>Chicago,</td> <td>156, 158 Lake St.</td> <td></td> </tr> <tr> <td>Philadelphia,</td> <td>608 Chestnut St. M. R. Muckle, Jr. & Co.</td> <td></td> </tr> </table> <p>ST. LOUIS, 511 NORTH FOURTH ST., Westinghouse, Church, Kerr & Co.</p> <table border="0"> <tr> <td>Salt Lake City,</td> <td>259 S. Main St.</td> <td rowspan="2">} Utah & Montana Machinery Co.</td> </tr> <tr> <td>Butte, Mont.</td> <td>2. Granite St.</td> </tr> <tr> <td>San Francisco,</td> <td>21, 23 Fremont Street,</td> <td rowspan="2">} Parke & Lacy Co.</td> </tr> <tr> <td>Portland, Or.</td> <td>33, 35 N. Front St.</td> </tr> <tr> <td>Charlotte, N. C.</td> <td>36 College St.</td> <td rowspan="2">} The D. A. Tompkins Co.</td> </tr> <tr> <td>Atlanta, Ga.</td> <td>45 S. Prior St.</td> </tr> <tr> <td>Dallas, Tex.</td> <td></td> <td rowspan="2">} Keating Imp. & Machine Co. C. E. James & Co.</td> </tr> <tr> <td>Chattanooga, Tenn.,</td> <td></td> </tr> </table>	New York,	17 Cortlandt St.	} Westinghouse, Church, Kerr & Co.	Boston,	Hathaway Building,	Pittsburgh,	Westinghouse Build'g,	Chicago,	156, 158 Lake St.		Philadelphia,	608 Chestnut St. M. R. Muckle, Jr. & Co.		Salt Lake City,	259 S. Main St.	} Utah & Montana Machinery Co.	Butte, Mont.	2. Granite St.	San Francisco,	21, 23 Fremont Street,	} Parke & Lacy Co.	Portland, Or.	33, 35 N. Front St.	Charlotte, N. C.	36 College St.	} The D. A. Tompkins Co.	Atlanta, Ga.	45 S. Prior St.	Dallas, Tex.		} Keating Imp. & Machine Co. C. E. James & Co.	Chattanooga, Tenn.,	
New York,	17 Cortlandt St.	} Westinghouse, Church, Kerr & Co.																																	
Boston,	Hathaway Building,																																		
Pittsburgh,	Westinghouse Build'g,																																		
Chicago,	156, 158 Lake St.																																		
Philadelphia,	608 Chestnut St. M. R. Muckle, Jr. & Co.																																		
Salt Lake City,	259 S. Main St.	} Utah & Montana Machinery Co.																																	
Butte, Mont.	2. Granite St.																																		
San Francisco,	21, 23 Fremont Street,	} Parke & Lacy Co.																																	
Portland, Or.	33, 35 N. Front St.																																		
Charlotte, N. C.	36 College St.	} The D. A. Tompkins Co.																																	
Atlanta, Ga.	45 S. Prior St.																																		
Dallas, Tex.		} Keating Imp. & Machine Co. C. E. James & Co.																																	
Chattanooga, Tenn.,																																			

Newbigging's Handbook for Gas Engineers and Managers.

The present (the fifth) edition marks an important advance on those that have gone before. Considerable additions have been made to the text, and much of it has been re-written and otherwise improved. It extends to 524 pages, and contains 193 illustrations. Price, Cloth, \$6.00.

A. M. CALLENDER & CO., - - - - No. 42 Pine Street, N. Y. City.

GAS AND WATER PIPES.

GAS AND WATER PIPES.

ENGINEERS.

SAM'L R. SHIPLEY, Pre-
HENRY B. CHEW, Tre

JAS. P. MICHELLON, Sec.
WM. SEXTON, Supt.

GLOUCESTER IRON WORKS,
GLOUCESTER CITY, N. J.



Cast Iron Gas & Water Pipes, Stop Valves, Fire Hydrants, Gasholders. &c.

Office, Rooms 61 and 63 Bullitt Building, 131 S. 4th St., Phila., Pa.

WARREN FOUNDRY AND MACHINE CO.,

Established 1856. Works at Phillipsburgh, N. J.

New York Office, 160 Broadway.

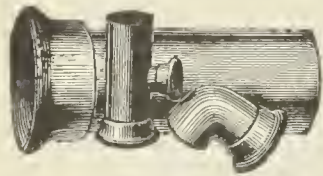

CAST IRON WATER AND GAS PIPE,

FROM TWO TO FORTY-EIGHT INCHES DIAMETER. ALSO, ALL SIZES OF

Flange Pipe for Sugar House and Mine Work. Branches, Bends, Retorts, etc., etc.

DENNIS LONG & COMPANY,

LOUISVILLE, KY.,



Manufacture Exclusively

CAST IRON GAS & WATER PIPE & SPECIAL CASTINGS
OF ALL SIZES.

King's Treatise on Coal Gas.

A standard text-book for the Engineers and Managers of Gas Works, and for all who are concerned or take an interest in the manufacture and distribution of Coal Gas, and in the utilization of the Secondary Products resulting therefrom; treating also of the Gas Engine, and of Gas Cooking and Heating Appliances

In 3 Vols. Price per Vol., \$10. Sold either by Volume or in Sets.

A M. CALLENDER & CO., 42 Pine St., N. Y.

P. D. WANNER, Chairman. A. H. MELLERT, Mangr. of Wks.
R. B. KINSEY, Secretary. F. A. KNOPP, Treasurer.

MELLERT FOUNDRY & MACHINE CO. Ltd.
and **READING FOUNDRY CO., Ltd.**
Reading, Pa.



Specials—Flange Pipe, Valves and Hydrants
Lamp Posts, Retorts, etc.
General Foundry and Machine Work.
JOHN FOX, Selling Agent 160 Broadway, N.Y.

THE OHIO PIPE COMPANY,

MANUFACTURERS OF

Cast Iron Gas & Water Pipe,
BRANCH AND SPECIAL CASTINGS.

Gas-House Bench Castings, Hydraulics, Lamp Posts, Flange Pipe
and Specials, Architectural Castings, Building Columns,
Joists, Cellar Grates, Sash Weights, etc.

GENERAL FOUNDERS AND MACHINISTS.
Columbus, Ohio.

M. J. DRUMMOND,



SPECIAL CASTINGS AND LAMP POSTS.
Office, Corbin Building, 192 Broadway, N. Y.

EMAUS PIPE FOUNDRY.

DONALDSON IRON COMPANY. EMAUS, PA.



MANUFACTURERS OF

CAST IRON PIPE AND SPECIAL CASTINGS
FOR WATER AND GAS.

JOS. R. THOMAS,

No. 42 Pine Street, N.Y. City.

CONSULTING AND CONSTRUCTING
Gas Engineer and Contractor.

PLANS, SPECIFICATIONS, AND ESTIMATES
FURNISHED.

Contracts taken for all Appliances
required at a Gas Works,
Either for New Works or Extensions to Old Plants.

WM. MOONEY

(Successor to WM. FARMER)

No. 94 Liberty St., N. Y. City.

GAS ENGINEER AND CONTRACTOR FOR THE ERECTION
OF GAS WORKS, OR APPARATUS OF ANY
CAPACITY.

Plans and Specifications Furnished.

WM. GARDNER,
Gas Engineer,

Lewis Block, Room 20, Pittsburgh, Pa.

Those who intend to make alterations in existing gas plants, or who contemplate the erection of new works, will find it to their interest to open correspondence with the above. Plans made and estimates furnished.

BARTLETT, HAYWARD & CO.

Baltimore, Md.

Triple Double, & Single-Lift
GASHOLDERS.

Iron Holder Tanks.

ROOF FRAMES.

Cirders.

BEAMS.

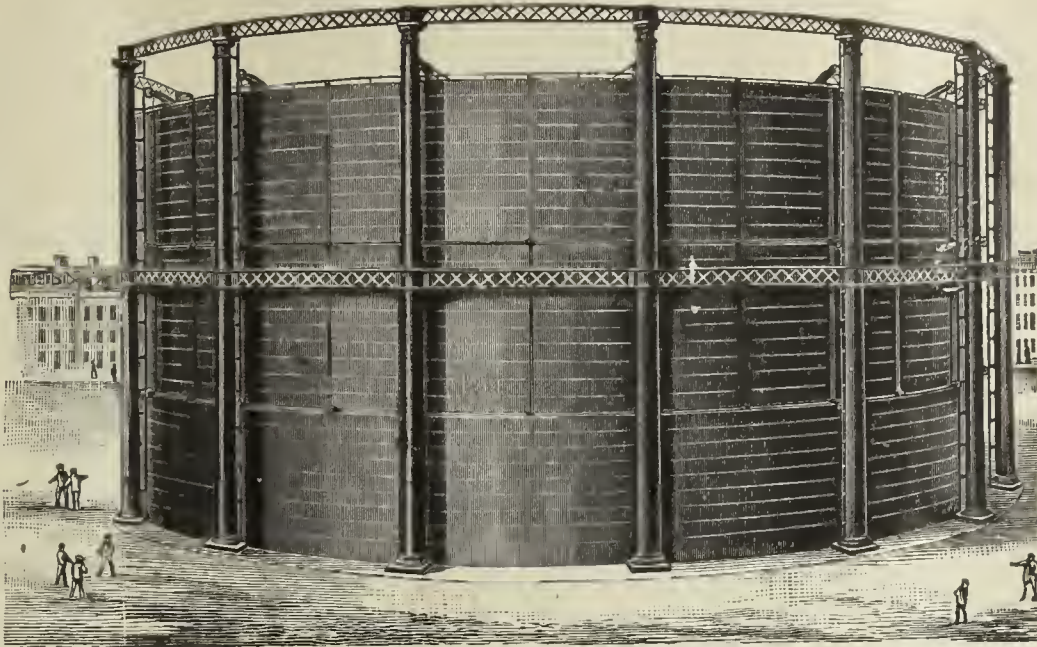

PURIFIERS.

CONDENSERS.

Scrubbers.

BENCH CASTINGS.

OIL STORAGE TANKS.

Boilers.

The Wilkinson Water Gas Process.

THIRTY-CANDLE, NON-CONDENSABLE, FIXED GAS. THE MOST SUCCESSFUL GAS PROCESS IN OPERATION.

Munich Regenerative Furnace, System Drs. Schilling & Bunte.

HAZELTON BOILERS.

Gas Works Designed and Constructed.

Pascal Iron Works. ESTABLISHED 1821. Delaware Iron Works.

MORRIS, TASKER & CO.,

INCORPORATED.

OFFICE, 224 SOUTH THIRD STREET, - - PHILADELPHIA, PA.

CONTRACTORS, BUILDERS, AND MANUFACTURERS OF

Gas, Water & Sugar Works

Bench Castings.

Condensers.

Scrubbers.

Purifiers.

Hyd. Carriages.

Iron Floors,

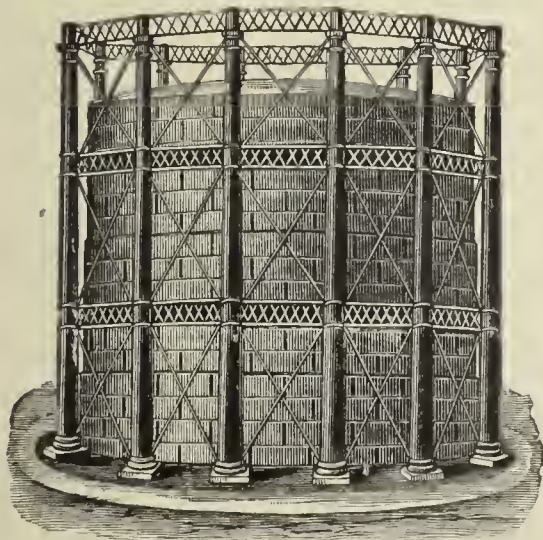

Iron Roofs.

Street Stops,

Valves, etc.

Stand-Pipes.

Water & Oil

Tanks, all Sizes.

Single, Double, and Triple-Lift Gas Holders.

SELF-SEALING RETORT LIDS. STAMPED STEEL RETORT LIDS.

Locomotive Water Columns, Filters, etc. Boiler Tubes, Wrought Iron Pipe & Fittings

Plans, Specifications and Estimates for all kinds of Machinery furnished on application.

Foundries & Works,
MILLVILLE, FLORENCE,
and CAMDEN, N. J.

R. D. WOOD & CO.,

Engineers,
Iron Founders,
and
Machinists.

400 Chestnut St., PHILADELPHIA, PA.

MANUFACTURERS OF

CAST IRON PIPE,

Gas Holders,

SINGLE, DOUBLE, AND TRIPLE LIFTS, WITH
OR WITHOUT WROUGHT IRON
OR STEEL TANKS.

PURIFIERS, CONDENSERS.

Scrubbers.

BENCH WORK.

Iron Floors and Roofs, Plate Girders.

Heavy Loam Castings.

HYDRAULIC WORK.

Lamp Posts, Valves, Etc.

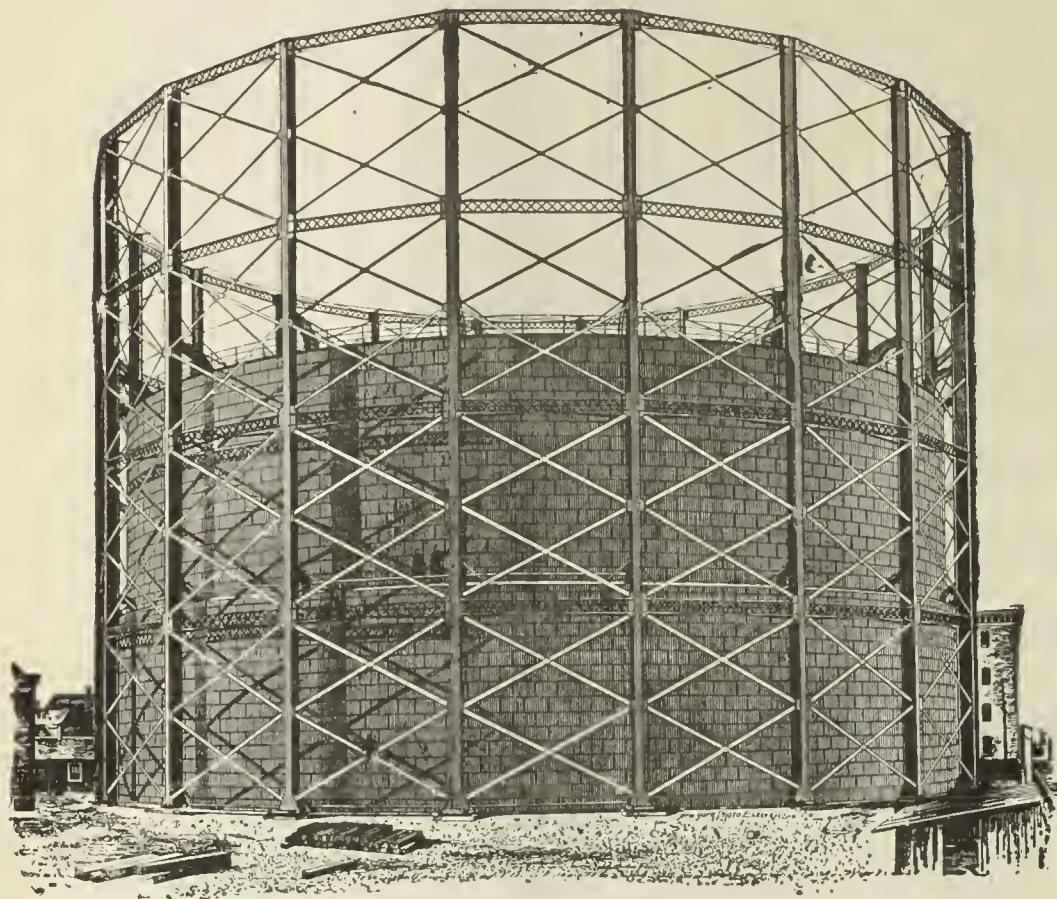

SMITH & SAYRE MFG. COMPANY,

G. G. PORTER, Prest.

245 Broadway, N. Y.

CHAS. W. ISBELL, Sec'y.

Machinery & Apparatus for Gas Works

Drawings, Plans, and Estimates Furnished for the Improvement, Extension, or Alteration of Gas Works, or for the Construction of New Works.

Mackenzie's Patent Rotary and Steam Jet Gas Exhausters, Governors, Compensators, Condensers, Washers, Scrubbers. Isbell's Patent Automatic Street Pressure Governor, Gas and Water Valves, Hydraulic Main Dip Regulator, Bench Castings, etc. Purifying Boxes and "Standard" Scrubbers, Isbell's Patent Self-Sealing Retort Doors.

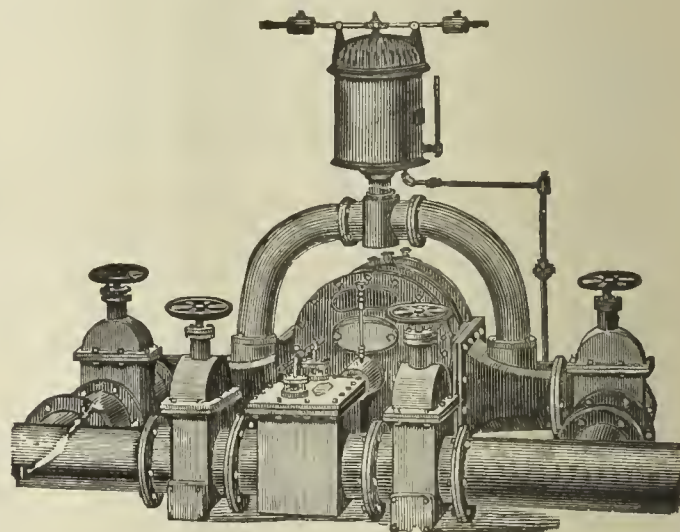

THE BRENNER SELF-SEALING RETORT DOOR.

Simple, Strong, and Durable.

CLOSES ABSOLUTELY TIGHT & IS LOCKED BY A CAM LEVER. ALL NECESSARY ADJUSTMENT FOR WEAR PROVIDED.

BUILT BY

SMITH & SAYRE MFG. CO.,

No. 245 Broadway, - - - New York City.

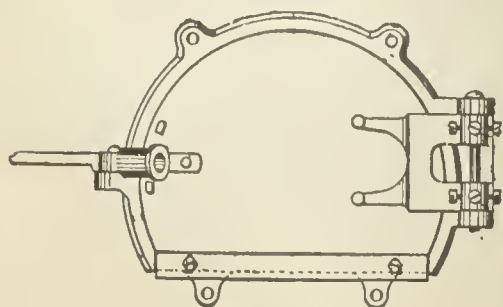

Brenner Self-Sealing Retort Door.

WILLIAM B. LUNDIE, Superintendent of the 42d Street Station of the Consolidated Gas Company, of New York, writes, under date of Jan. 4, 1889:

"We have 320 Brenner Self-Sealing Lids in use at this Station, built by the Smith & Sayre Mfg. Co. They require very little attention, and are the best of the kind that I have seen, giving entire satisfaction."

GAS WORKS APPARATUS AND CONSTRUCTION.

GAS WORKS APPARATUS AND CONSTRUCTION.

JAMES R. FLOYD & SONS,

(SUCCESSORS TO HERRING & FLOYD)

Oregon Iron Works,

W. 20th & 21st. Sts., bet. 10th & 11th Avs.,

NEW YORK CITY.

Engineers and Contractors

FOR THE

CONSTRUCTION OF GAS WORKS.

MANUFACTURERS OF

All Kinds of Castings and General Ironwork

FOR

GAS APPARATUS.

Bench Castings, Regenerative and Half Regenerative Furnace Castings.

Condensers, Scrubbers, Purifiers, Street Drips and Connections,

Valves,

Hydraulic Hoisting Purifier Carriage, Self-Sealing Retort Lids, Improved Valve Stand and Indicator,

Seller's Cement.

Plans, Specifications, and Estimates furnished for Construction of New or Alteration of Old Works.

CONTINENTAL IRON WORKS.

THOS. F. ROWLAND, Prest.

WARREN E. HILL and CHAS. H. CORBETT, V-Prests.

THOS. F. ROWLAND, JR., Sec. & Tr

P. O. Station G., BROOKLYN, N. Y.

ENGINEERS AND MANUFACTURERS OF

Gas Holders

CONDENSERS, SCRUBBERS, VALVES,

PURIFIERS, SELF-SEALING RETORT LIDS

Hydraulic Mains,

And all other articles connected with the manufacture and distribution of Gas.

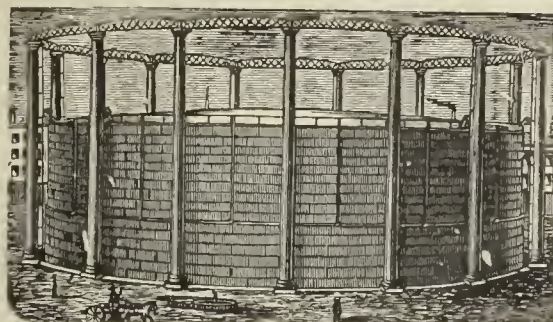

H. RANSHAW, Prest. & Mangr.

WM. STACEY, Vice-Prest.

T. H. BIRCH, Asst. Mangr.

R. J. TARVIN, Sec. & Treas.

STACEY MFG. CO.,

MANUFACTURERS OF

Single and Telescopic Gasholders,

IRON ROOFS, BRIDGES, LAMP POSTS,

Water and Oil Tanks, Coal Elevator Cars,

COKE CRUSHERS, BENCH CASTINGS,

And all kinds of Wrought and Cast Iron Work used in the erection of Coal and Oil Gas Works Rolling Mill Machinery and Heavy Castings a Specialty.

Foundry:

33, 35, 37 & 39 Mill Street.

Wrought Iron Works:

16, 18, 20, 22, 24 & 26 Ramsey Street:

Cincinnati, Ohio.

Bouton Foundry Co.,

FOUNDERS AND MACHINISTS,

CHICAGO, ILL.

Gas Works Apparatus,

PURIFIERS, CONDENSERS,

Bench Work

SPECIALS, LAMP POSTS,

SCRUBBERS,

Iron Roofs and Floors.

Plans and Estimates furnished for new works or extensions of old works.

1842. DEILY & FOWLER, 1890 Laurel Iron Works.

Address, No. 39 Laurel Street, Philadelphia, Pa.

BUILDERS OF

GASHOLDERS,

Single and Telescopic.

Holdings Built 1884 to 1888, Inclusive:

Newport, R. I.	Long Island City, N. Y.	Port Chester, N. Y.	Malden, Mass.	West Chester, Pa. (2d)
Portland, Oregon.	Macon, Ga.	New Rochelle, N. Y.	Paducah, Ky.	Lancaster, Pa. (3d)
Allegheny, Pa. (2d.)	York, Pa.	Salem, N. J. (3d)	Norwich, Conn.	Faony, Pa. (two)
Atlanta, Ga. (2d.)	Chester, Pa.	Omaha, Neb. (2d)	Seattle, W. T.	Mount Vernon, N. Y.
N.Y. City (Central Gas Co)	Hazleton, Pa. (2d.)	Lynn, Mass. (2d)	San Diego, Cal.	Binghamton, N. Y.
Lynchburg, Va. (2d.)	Staten Island, N. Y.	Little Rock, Ark.	Northern Gas Lt. Co., of	Concord, N. H.
Saylesville, R. I.	Saugerties, N. Y.	Irvington, N. Y.	New York, N. Y.	Dover, Del. (2d)
Rondout, N. Y.	Clinton, Mass. (Lan. Mills)	South Boston, Mass.	Westerly, R. I.	(alais, Me.
Atlantic City, N. J.	Chattanooga, Tenn.	Rye, N. Y. (2)	Willimantic, Conn	New London, Conn. (2d)
Augusta, Ga.	Galveston, Texas. (3d.)	Woodstock, Ont.	Montclair, N. J.	West Chester, N. Y.
Waltham, Mass. (2)	Omaha, Neb.	Malden, Mass.	Attleboro, Mass.	Bay Shore, L. I.
Mahanoy City, Pa.	Fort Plain, N. Y.	Staten Island, N. Y. (2d)	Santa Cruz, Cal.	Washington, D. C.
New Castle, Pa.	Brunswick, Ga.	Woodstock, Ont.	Erie, Pa. (2d)	

WM. HENRY WHITE,

No. 32 Pine Street, - - - New York City.

ENGINEER AND CONTRACTOR FOR THE

Erection and Extension of Gas, Water, and Electric Light Works.

SOLE REPRESENTATIVE OF THE

McILHENNY REGENERATOR FURNACE PATENTS

And the Martin Water Gas Process.

Edison Incandescent and American Arc Electric Light Plants Installed.

Correspondence with Gas Companies contemplating extending or improving their Plants respectfully invited. Plans and Estimates Furnished.

GAS COALS.

CANNEL COALS.

GAS ENRICHERS.

JAMES D. PERKINS. **PERKINS & CO.,** F. SEAVERN.
228 & 229 Produce Exchange, New York.

Cable Address, "PERKINS, NEW YORK."

Post Office Box 3695, New York.

GENERAL SALES AGENTS FOR

The Youghiogheny River Coal Company's

OCEAN MINE YOUGHIOGHENY GAS COAL.

HON. W. L. SCOTT, Prest.

M. H. TAYLOR, Vice-Prest.

This Colliery is located at SCOTT HAVEN, PA., in the center of the Youghiogheny Gas Coal District, and produces the ONLY RELIABLE YOUGHIOGHENY COAL for gas purposes. (See Map on p. 87 of this JOURNAL, Feb. 16, '85.)

POINTS OF SHIPMENT,

Locust Point, BALTIMORE.

Pier No. 62, PHILADELPHIA.

Also, SOLE AGENTS for the

**BRECKENRIDGE CANNEL,
OF KENTUCKY.**

Within the past two years we have delivered this Cannel to over ONE HUNDRED COMPANIES IN THIRTY-THREE DIFFERENT STATES, and it is now in use in some of the large Gas Works

On the Continent and in South America,

where it successfully competes with the Australian Shale. It is the ONLY AMERICAN GAS CANNEL of sufficiently high grade to warrant EXPORTATION TO EUROPE AND SOUTH AMERICA, and it is the only economical substitute for OIL OR NAPHTHA. ONE GROSS TON will produce

10,000 Cubic Feet of 75 Candle Gas,	} equal to {	750,000 Candle Feet of Gas, and 26 Bushels of merchantable Coke weighing 900 Pounds
or 12,500 " " 60 " "		
or 15,000 " " 50 " "		

This is the ONLY GAS CANNEL that will produce a REALLY MERCHANTABLE COKE. It can be delivered in parcels of one carload or more to any point in the United States or Canada. Cargo shipments of any size required can be made from NEW YORK, PHILADELPHIA, BALTIMORE, or NEWPORT NEWS. Samples will be sent and particulars of price, etc., forwarded upon application to above address.

JAMES & WILLIAM WOOD,
Gas and Cannel Coal Contractors,

No. 40 St. Enoch Sq., Glasgow. No. 2 Talbot Court, London.

Proprietors of the BATHVILLE COLLIERIES (which produce the celebrated BOGHEAD CANNEL), Shields, Shieldmuir, Drumpeller, and other Collieries. This Firm offer

STANDARD CANNELS,

Unequaled as Gas Enrichers.

Also, WEST FAIRMONT GAS COAL, of W. Va.

Analyses, prices, and all further information furnished on application to

Agency for U. S., Room 70 Nos. 2 & 4 Stone St., N.Y. C. ty.

The Standard Oil Company,

REFINERS OF

NAPHTHA AND GASOLINES.

ALSO MANUFACTURERS OF

A Special Grade of Naptha for Gas Companies

FOR ENRICHING COAL GAS.

Correspondence solicited.

No. 43 Euclid Avenue, Cleveland, Ohio.

To Gas Companies.

We make to order CAP BURNERS to burn any amount under a stated pressure. Send for samples.

Also, SERVICE CLEANERS, DRIP PUMPS, and STREET MAIN PROVING APPARATUS.

C. A. GEFRORER,

248 N 8th Street, Phila., Pa.

COKE CRUSHERS.

GAS COALS.

GAS COALS.

Newburgh Orrel Coal and Coke Co.

MINERS AND SHIPPERS OF

STEAM, SMITHING, AND GAS COALS,
Foundry and Crushed Coke.

Home Office, 33 S. Gay Street, Baltimore, Md.

J. HARRY LEE, President.

Shipping Wharves, Locust Point, Baltimore.

The Despard Gas Coal Co.,

MINERS AND SHIPPERS OF

DESPARD GAS COAL,

AND MANUFACTURERS OF

COKE.

MINES, Clarksburg, Harrison Co., W. Va.

WHARVES, Locust Point, Baltimore, Md.

OFFICE, 225 E. German St., " "

ROUSSEL & HICKS, } AGENTS. } BANGS & HORTON,
71 Broadway, N. Y. } 60 Congress St., Boston.

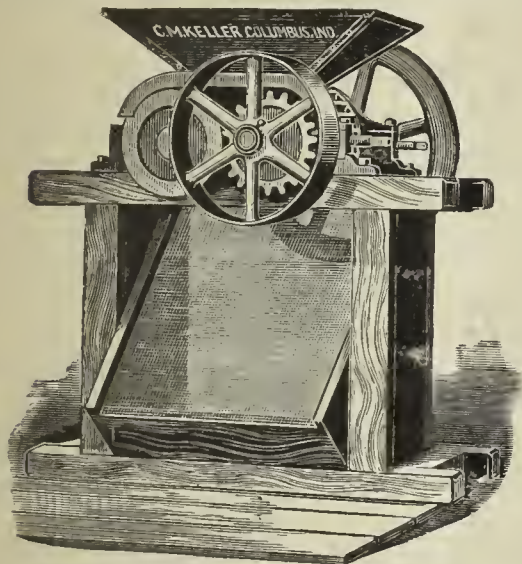

Keller's Adjustable Coke Crusher

SIMPLE, STRONG, AND DURABLE.

C. M. Keller, Sec. & Supt. Gas Lt. & Coke Co. Columbus, Ind.

Correspondence Solicited.

King's Treatise on Coal Gas.

The most complete work on Coal Gas ever published.

Three Vols. Bound, \$30.

BOOKS.

DISTILLATION OF COAL TAR AND AMMONIACAL LIQUOR.

By GEORGE LUNGE. Price \$12.50.

A TREATISE ON THE COMPARATIVE COMMERCIAL VALUES OF GAS COALS AND CANNELS.

By DAVID A. GRAHAM. 8vo., Cloth. Price \$3.

Orders for these books may be sent to this office.

A. M. CALLENDER & CO.,

42 PINE ST., N. Y. CITY

THE PENN GAS COAL CO.

OFFER THEIR

Coal, Carefully Screened & Prepared for Gas Purposes.

Their Property is located in the Youghiogheny Coal Basin, near Irwin and Penn Stations on the Pennsylvania Railroad, and on the Youghiogheny River.

Principal Office:

209 SOUTH THIRD STREET, PHILA., PA.

Points of Shipment:

Pennsylvania Railroad Piers; Greenwich Wharves, Delaware River; Pier No. 1 (Lower Side), South Amboy, N. J.

Chesapeake & Ohio Railway Coal Agency,

FOR THE SALE OF THE

Superior Kanawha Gas Coals, Cannelton Cannel, Also, SPLINT AND STEAM COALS.

From the Kanawha and New River Regions, on the line of the Chesapeake & Ohio R'way.

C. B. ORCUTT, General Agent, - - No. 1 Broadway (Room 217) New York City.

FRANCIS H. JACKSON, Prest. EDMUND H. MCCULLOUGH, V.-Prest. CHAS. F. GODSHALL, Treas. H. C. ADAMS, Sec.

THE WESTMORELAND COAL CO.

Chartered 1854.

Mines situated on the Pennsylvania and the Baltimore and Ohio Railroads, in Westmoreland County, Penn.

POINTS OF SHIPMENT:

PHILADELPHIA, BALTIMORE, SOUTH AMBOY, N. J., WATKINS (SENECA LAKE), N. Y.

Since the commencement of operations by this Company its well-known Coal has been largely used by the Gas Companies of New England and the Middle States, and its character is established as having no superior in gas-giving qualities, and in freedom from sulphur and other impurities.

Principal Office, 224 South 3d St., Phila., Pa.

The American Gas Engineer and Superintendent's Handbook.

By WILLIAM MOONEY.

Consisting of Rules, Reference Tables, and Original Matter Pertaining to the Manufacture, Manipulation, and Distribution of Illuminating Gas.

350 Pages, Full Cilt Morocco.

\$3.00.

A. M. CALLENDER & CO., 42 Pine St., N. Y.

JOHN J. GRIFFIN & CO.,

Nos. 1513, 1515, 1517 & 1519 Race Street, PHILADELPHIA.
52 Dey St., NEW YORK. 75 N. Clinton St., (FRED. R. PERSONS, Mangr.) CHICAGO.

MANUFACTURERS OF

METERS FOR MEASURING GAS

IN ANY VOLUME.

Provers, Gauges, Registers, Etc., Etc

EXPERIMENTAL APPARATUS FOR QUANTITATIVE AND QUALITATIVE ANALYSIS.

Careful and Prompt Attention paid to Repairing of all kinds of Meters and Apparatus.

Estimates Cheerfully Furnished.

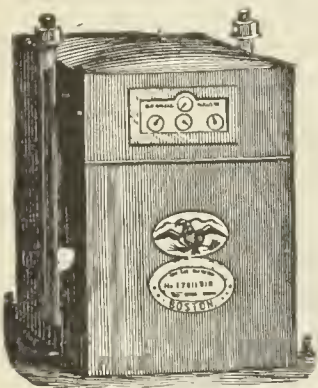

Dry Gas Meters.

With 40 years' experience and the best facilities for manufacturing, is enabled to furnish reliable work and answer orders promptly.

NATHANIEL TUFTS,

No. 153 Franklin Street, Boston, Mass.,

MANUFACTURER OF

DRY GAS METERS.

Station Meters of any Capacity.

Test and Experimental Meters, Pressure Registers, Pressure Gauges, Pressure and Vacuum Gauges.

METER PROVERS, PHOTOMETERS, STREET LANTERNS, ETC., ETC.

Patent Cluster Lanterns for Street Illumination.

HAROLD J. BELL.

BELL & JONES,

S. LEWIS JONES.

No. 12 North Ninth Street, Philadelphia, Pa. Works at Royersford, Pa.

MANUFACTURERS OF

GAS METERS, STATION AND EXPERIMENTAL METERS,

Meter Provers, Pressure Gauges, and All Other Gas Appliances in Our Line.

WE REPAIR ALL KINDS AND MAKES OF METERS, AND THE WORK GUARANTEED.

High Pressure Meters for Natural Gas, in Iron Cases, guaranteed to stand 300 lbs. Pressure.

Gas Cooking and Heating Stoves, Hot Plates, Cake Griddles, Waffle Bakers, Boiling Stoves, Laundry and Tailors' Iron Heaters. Hotel and Cafe Ranges a Specialty.

Correspondence Solicited.

Estimates Furnished.

A. HARRIS.

E. L. HARRIS.

J. A. HARRIS.

Established 1849.

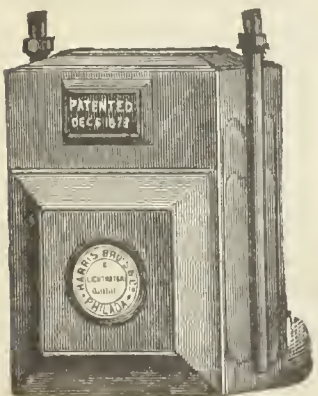

HARRIS BROS. & CO.,

Twelfth and Brown Streets, Philadelphia.

Manufacturers of Wet and Dry Gas Meters,

STATION METERS, METER PROVERS,

EXPERIMENTAL METERS, SHOW OR GLAZED METERS,

Pressure and Vacuum Registers, Gauges, Photometers, Drip and Bell Pumps, Etc., Etc.

PROMPT ATTENTION GIVEN TO ALL ORDERS. METERS THOROUGHLY REPAIRED. ESTIMATES FURNISHED FOR STATION METERS OF ALL SIZES. CORRESPONDENCE SOLICITED.

GAS METERS.

GAS METERS.

GAS METERS.

GEO. J. MCGOURKEY, Prest.

WM. H. MCFADDEN, Vice-Prest. (Phila.)

WM. N. MILSTED, Gen. Supt. and Treas. (New York).

WM. H. DOWN, Sec.

THE AMERICAN METER CO.

WET AND DRY GAS METERS.

PRESSURE REGISTERS.

METER PROVERS.

STATION METERS.

PRESSURE & VACUUM REGISTERS.

PORTABLE TEST METERS.

EXHAUSTER GOVERNORS.

PRESSURE & VACUUM GAUGES.

EXPERIMENTAL METERS.

DRY CENTER VALVES.

CRESSON GAS REGULATORS.

AMMONIA TEST METERS.

GOVERNORS FOR GAS WORKS

MARSLAND WATER METERS.

BAR & JET PHOTOMETERS.

Manufactories:

512 West 22d St., N. Y.
Arch & 22d Sts., Phila.

GAS STOVES.

SUGG'S "STANDARD" ARGAND BURNERS,
SUGG'S ILLUMINATING POWER METER,
Wet Meters, with Lizar's "Invariable Measuring" Drum.

Agencies:

177 Elm Street, Cincinnati.
244 & 246 N. Wells Street, Chicago.
S10 North Second Street, St. Louis.
222 Sutter Street, San Francisco.

HELME & McILHENNY,

(Established 1848.)

GAS METER MANUFACTURERS,

Nos. 1339 to 1349 Cherry Street, Philadelphia, Pa.,

WET AND DRY GAS METERS, STATION METERS, EXPERIMENTAL METERS, METER PROVERS,

Center Seals, Pressure Registers, Governors, Indicators, Photometers, and all other kinds of Apparatus for use in Gas Works.

FOULIS' PATENT STATION AND DISTRICT GOVERNORS.

REPAIRING DEPARTMENT.—We employ a special force of skilled workmen repairing meters of all makers.

WM. WALLACE GOODWIN, President and Treasurer.

E. STEIN, Vice-President.

H. B. GOODWIN, Secretary and Superintendent.

THE GOODWIN GAS STOVE AND METER CO.,

Successors to W. W. GOODWIN & CO.

1012, 1014 and 1016 Filbert St., Phila., Pa.

142 Chambers St., New York City.

76 Dearborn, St., Chicago, Ills

WALDO BROTHERS, Agents, 88 Water Streets, Boston, Mass.

MANUFACTURERS OF

DRY AND WET GAS METERS,

Station Meters (square, cylindrical, or in staves), Glazed Meters, King's and Sugg's Experimental Meters, Lamp Post Meters, etc., etc. Meter Provers (sizes 2, 5, and 10 feet). Pressure Gauges of all kinds, Pressure Registers, Pressure and Vacuum Registers, Pressure Indicators (sizes 4, 6, and 9 inch), King's Pressure and Vacuum Gauges, Dry and Wet Center Seals, Dry and Wet Governors, Exhauster Governors, Photometers of all descriptions. Letheby's Sulphur and Ammonia Test Apparatus complete. Also, Testing and Chemical Apparatus of all kinds, and of the most perfect description, for all purposes relating to Gas.

Manufacturers of the "SUN DIAL" GAS STOVES, for Cooking and Heating.

Goodwin's Improved Lowe's Jet Photometer.

Agents for Bray's Patent Gas Burners and Lanterns.

Special attention to Repairs of Meters and all Apparatus connected with the business. All work guaranteed first-class in every particular. Orders filled promptly.

G. B. EDWARDS, Manager, New York.

S. S. STRATTON, Manager, Chicago.

D. MCDONALD & CO.,

GAS METER MANUFACTURERS.

(Established 1854.)

51 Lancaster St., Albany, N. Y. 34 & 36 West Monroe St., Chicago, Ill.

STATION METERS, EXPERIMENTAL METERS, METER PROVERS, PRESSURE & VACUUM REGISTERS, PRESSURE GAUGES, ETC

Also STAR GAS STOVES, RANGES, and HEATING STOVES.

We use only the very best materials, and employ the most skilled labor, and by our long experience (32 years) and personal supervision of every detail, we feel justified in assuring the public that our goods will give perfect satisfaction. Every Meter emanating from our establishment will bear the State Inspector's Badge, and will be fully warranted by us. Our Annual and Calendar will be sent to Gas Companies upon application.

WM. WALLACE GOODWIN, President. E. STEIN, Vice-President. H. B. GOODWIN, Sec. & Supt. G. B. EDWARDS, Mang'r, New York. S. S. STRATON, Mang'r, Chicago.

THE GOODWIN GAS STOVE AND METER CO.,

1012-18 Filbert St., Phila., 142 Chambers St., N. Y., 76 Dearborn St., Chicago.

Agents, WALDO BROTHERS, 88 Water Street, Boston.

SOLE MANUFACTURERS OF THE

“SUN DIAL” GAS STOVES,

The Most Economical, Efficient, and Durable Gas Stove Made.

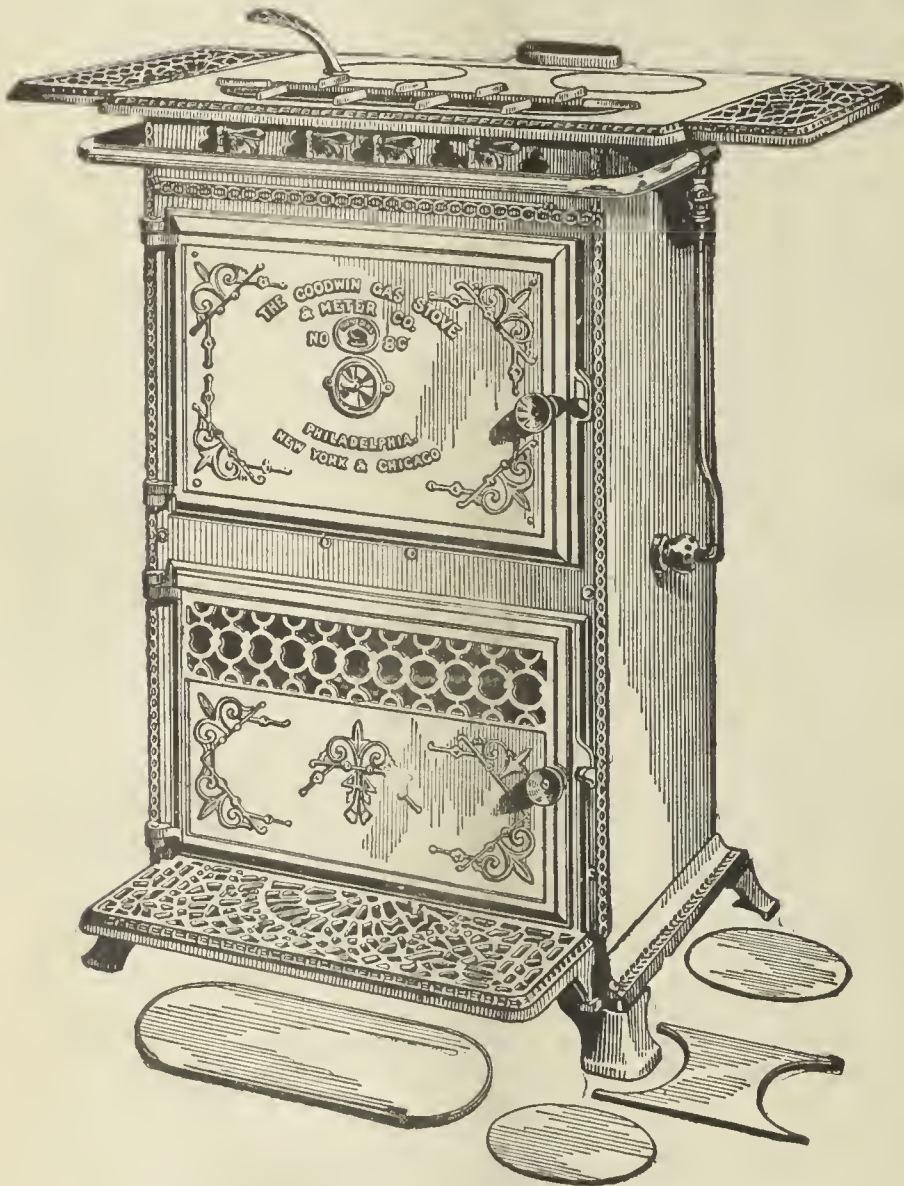

GAS COOKING STOVE, No. 8 C.

SIZE.

Stove.	Oven.	Roaster.	Top.	Length over Ex-
37 in. high.	12 in. high.	12 in. high.	24 in. long.	tension Shelves,
20 in. wide.	17½ in. wide.	15 in. wide.	21 in. wide.	36 in.
	12 in. deep.	13 in. deep.		

This Stove has four burners on top, and double oven burner. Consumption of gas with all burners in use, 42 feet per hour, at 1 inch pressure. The top is made in sections, so that a greater variety of cooking utensils may be used. By lifting out the covers and crosspieces and putting in a suitable forked ring, which is sent with each stove, a wash boiler or other large utensil may be set over two burners. Our No. 87 GRIDDLE also fits in the same position. The roasting oven is provided with a cast iron door.

All Fittings are Nickel-Plated.

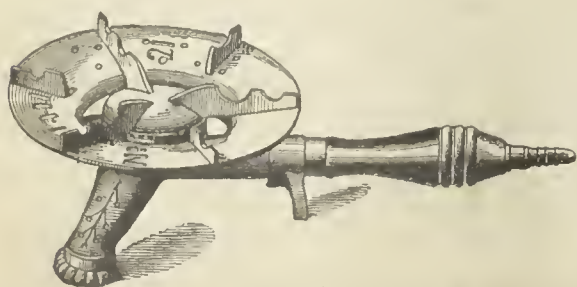

“RADIANT” BOILING STOVE, WITH REGENERATIVE BURNER.

Size, 6½ inches diameter, 8 inches high. Consumption, 6 feet per hour at 1 in. pressure.



GAS COOKING STOVE, No. 7 B.

SIZE.

Stove.	Oven.	Roaster.	Top.	Length over Ex-
31 in. high.	9½ in. high.	10 in. high.	21 in. long.	tension Shelves,
17 in. wide.	14½ in. wide.	15 in. wide.	16 in. wide.	32 in.
	12 in. deep.	13 in. deep.		

This Stove has three boiling burners in the Top or Hot Plate, and one single oven burner.

This cut represents our New Style Cooking Stove. As will be seen, it has an ornamented cast-iron Base and Front, and extension shelves. The Oven Burner, which is atmospheric (unless otherwise ordered), is of an entirely new and improved pattern (patent). The Top, in conjunction with the Outlet Pipe, is designed to carry off all the products of combustion, if desired, but they are also supplied with a loose ring which converts it into an ordinary open top stove.

The consumption of this Stove is 35 cubic feet per hour at 1 inch pressure, with all Burners in use.

All Fittings are Nickel-Plated.

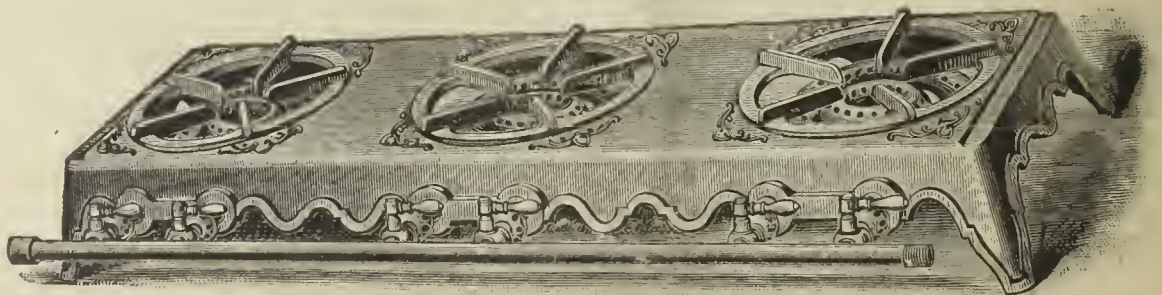

HOT PLATE, No. 111.

Size, 36 in. long, 12 in. wide, with three double burners, 6 taps. Consumption, with all burners in use, 36 cubic feet per hour, with 1 in. pressure. ½ in. supply pipe should be used where the pressure is 1 in. or over.

THE AMERICAN

GAS LIGHT JOURNAL

REDMAN & KENNY, N. Y.

PUBLISHING OFFICE No. 42 PINE STREET

DEVOTED TO THE INTERESTS OF ILLUMINATION, VENTILATION, WATER SUPPLY AND DISTRIBUTION, & GENERAL SCIENCE.

VOLUME LII.—No. 16.
Whole No. 776.

NEW YORK, MONDAY, APRIL 21, 1890.

{ \$3 PER ANNUM,
IN ADVANCE.

A. M. CALLENDER & CO., Proprietors. C. E. SANDERSON, Manager.
JOS. R. THOMAS, C.E., Editor. T. J. CUNNINGHAM, Asst. Editor.

ENTERED AT THE POST OFFICE AT NEW YORK, N. Y.
AS SECOND CLASS MATTER.

Published on each Monday of the year, at No. 42 Pine Street, N. Y.

Terms of Subscription, Including Postage.—For the United States and Canada, \$3 per annum. European countries, \$4.50 (19 shillings—22½ francs). All payments to be made in advance. Single copies, 10 cents.

Remittances should be made either by post-office order, registered letter, or bank draft on New York, payable to the order of A. M. Callender & Co.

Collections are invariably made directly from this office, for subscriptions, advertisements, etc. We have agents to solicit the same, but they are not authorized to receipt for money.

Correspondence.—Wishing to make this JOURNAL a gazette of intelligent discussion to those of our readers who may wish to gain or give information on the subjects to which its columns are devoted, correspondence is solicited for publication from all who make the study of those subjects a pleasure or a profession.

The American News Company, Nos. 39 and 41 Chambers street, New York, are agents for this JOURNAL. Newsdealers will send orders to them.

Books.—We will forward by express, at publisher's lowest rates, any book—scientific or otherwise—to any address in the United States or Canada. No books will be sent C. O. D.

CONTENTS.

An Asterisk (*) denotes an illustrated article.

OFFICIAL NOTICE—

Western Gas Association..... 549

EDITORIALS—

Briefly Told..... 549

The Western's Thirteenth Annual—On to Washington once more—Annual Meeting, Rochester, Minn.—Notes.

The Market for Gas Securities 550

Sixth Annual Meeting, Ohio Gas Light Association.—Official Report

—Revised by the Secretary—Concluded from page 521..... 551

Second Day, Morning Session: Question-Box—A Telegram—Election of Officers—Report of Committee on President's Address—Back to the Question-Box—An Interjection—Adjournment.

*Experience with Subsided Gas Mains, by Mr. Wm. Drewry..... 557

*Conroy's Cut-Off and Relief Apparatus for Gas Mains..... 558

ITEMS OF INTEREST FROM VARIOUS LOCALITIES..... 559

Inspecting Municipal Gas Works—Explosion at New Rochelle, N. Y.—Annual Meeting, Fulton Municipal Company—Cheaper Gas, Doylestown, Pa.—Annual Meeting, Rome, N. Y.—Atlantic City (N. J.) Gas—New Holder, Malden, Mass.—Cheaper Gas, Hackensack, N. J.—The Troy Gas Company Purchases the Local Electric Plants—How the Move Succeeded at Alton, Ills.—New Gas Works, Florence, Ala.—Personals—Amending the Louisville Company's Charter—General Wagner's Annual Report—Liberal Management at Dedham, Mass.—The New Works at Austin, Ills.—The Brooklyn Company's Backdown—Mr. Sommerville to Remain in Charge—The Nebraska Gas and Fuel Company—And Many Other Items.

Coal Miners' Strikes and London Fuel Supply..... 561

Petroleum in Servia..... 561

[OFFICIAL NOTICE.]

Western Gas Association.

SECRETARY'S OFFICE, WESTERN GAS ASSOCIATION, }
QUINCY, ILLS., April 9, 1890. }

The Thirteenth Annual Meeting of the Western Gas Association will be held at St. Louis, Mo., on the 21st, 22d and 23d days of May. The Lindell Hotel will be used as our headquarters on this occasion.

The usual reduction in transportation rates has been secured and the necessary certificates for obtaining the same will be mailed to our members on or about the 10th of May.

On the 15th of February the Special Committee on the Assignment of Papers assembled at St. Louis for the purpose of choosing subjects and assigning authors for the same. It is a pleasure to state that the responses to the requests of this committee have, in almost every instance, been favorable. The Association can, therefore, rely upon the fact that the paper contributions to the Thirteenth Annual will be of a high order of merit. The list will be announced in these columns later on.

It gives me great satisfaction to be able to say to the members that the Executive Committee has decided upon a plan for the holding of an exhibition, on a large scale, of gas apparatus of all descriptions, the display to continue during the three days of the meeting. The exhibition room is located on the third floor of the new office building of the Laclede Gas Light Company, which room, besides being capacious and well lighted, is easily accessible on account of an excellent service of passenger and freight elevators. Beyond a doubt the members of the Association will recognize in this a most graceful and serviceable act on the part of the officers of the Laclede Company.

Although "The Western" contains on its lengthy membership list the names of a large number of executive officers of the gas companies that are embraced within its territory, the fact still exists—and it is a painful one—that there still remain a considerable proportion of our Western and Southern companies who have not yet sent delegates to our annual reunions. It is the intention of the Secretary to send a circular, calling attention to the great good accomplished by Gas Associations generally, to the President of each and every company that still remains unrepresented on our roll book, accompanied with a request that he shall send his Superintendent to our St. Louis meeting. These circulars will be issued at an early day, and will be mailed to every gas company President from the Alleghenies to the Rockies, and from the Great Lakes to the Gulf. If any of our members, or those who are contemplating becoming members, can lend a helping hand in this movement, they will confer a favor upon the Secretary. Application blanks and copies of our by-laws will be mailed to those who desire them.

A. W. LITTLETON, Sec'y.

BRIEFLY TOLD.

THE WESTERN'S THIRTEENTH ANNUAL.—Our readers no doubt have read with interest the current official notices now being printed in our columns over the signature of Secretary Littleton, respecting the Thirteenth Annual of the Western Association, which gathering is eagerly looked forward to, not by its own membership alone, but by almost

every gas man who is compelled by stern necessity or the travail of business to reside east of Chicago. At the outset, however, one's desire to foretaste the privileges and profits and pleasures of the coming convention at St. Louis, is lessened, in that a somber pall hangs dimly between the Association's last tryst and the one soon to be brought off, in that its President-elect—the lamented and esteemed E. J. King—having been called to "Sleep the sleep that knows not waking," will not sound the summons to duty. But in their grief his confreres may seek and surely find solace if not comfort in the knowledge that his example lives with them to stir them on to closer union in upholding the trusts committed to their care. It is also comforting to know that the reins that fell from the master's hands were grasped by one in every sense qualified to use them rightly in their capacity for direction. From the Secretary's notice it will be seen that he comes out in characteristic manner in the frank admission that the Special Committee on the Assignment of Papers has admirably answered the purpose for which it was formed, and we have from him the further satisfactory knowledge that those who were "named" by the Committee have not sought to evade the duty imposed on them. It is this spirit of union that has made the Western Association what it is, and it may be well understood that under the guidance of such sustained impulses the Western is not to be the thing of a day. Mention of the Association's superlative Secretary recalls the fact that he has been sadly bereaved in the recent death of his father, whose failing frame succumbed on the 12th inst., at his home in Lincoln, Ills. It is true that the senior Littleton had carried the burden of eighty years of life, but the burden seemed to rest so lightly that those nearest him imagined that more of life was to be his. We mention this, apart from our desire to tell the Secretary's friends of his bereavement, to follow it with the remark that despite his personal cares at such a time he still finds space wherein to prepare a herald of the coming meeting. We note with great satisfaction that the Executive Committee has determined upon an exhibition of apparatus connected with the manufacture, distribution and consumption of gas, and that said exhibition is to be held in the elegant and capacious lofts over the newly-finished offices of the Laclede Gas Light Company. Perhaps Egner may be said to be largely responsible for this determination—that is, in the matter of holding the exhibition—and it is certainly a most graceful act on the part of the Laclede Company to offer a house location for the display. We hardly suppose that any necessity exists for us to recall to the minds of the manufacturers of gas apparatus the advantages, of a purely commercial character, that are to be theirs from a practical participation in this exhibition. Mr. Egner has full charge of the arrangements for the exhibition, and this is a guarantee that fairness and absolute impartiality are to rule in the management of the affair. Exhibitors need not remove their goods until such time as will best serve their convenience—which is an extra inducement, perhaps, in the case of those who will contribute bulky articles to the display. In fact, we hope that every one of our advertisers will figure in the exhibition catalogue and on the floor or shelves of the exhibition room. It will pay them handsomely, too. Perhaps we may be forgiven for anticipating somewhat the matter that will appear in Mr. Littleton's succeeding official announcements, but in any event it may be whispered about that the Lindell is to be headquarters, and that the Local Committee of Arrangements have outlined a plan for the entertainment of the members, in the matters of banquet and outing, that is superb almost unto lavishness. More complete details of the meeting programme will follow in later issues.

ANNUAL MEETING, BRIDGEPORT, CONN.—The stockholders of the Bridgeport Gas Company elected the following Board of Directors on the 15th inst.: Messrs. Wm. R. Higby, Wm. D. Bishop, S. C. Trubee, H. L. Clark, Wm. H. Perry, H. Nichols, S. B. Beardsley, Wm. B. Hincks, and A. C. Hobbs. The following officers were elected: Prest., W. R. Higby; Sec. and Treas., F. B. Sammis; Supt., C. A. Gerdenier.

ON TO WASHINGTON ONCE MORE.—That picturesque party named Ingalls, who represents Iowa in a Senatorial capacity, has introduced, "by request," a bill to authorize the Commissioners of Washington, D. C., to provide illumination "by gas, or electric, or other lighting system." In furtherance of that proposition they are "authorized to purchase the plant of the Washington Gas Light Company, provided it can be bought at what it would cost to duplicate it," the assessment or valuation to be "set up by five experts." The bill also provides that if the Gas Company declines to sell, then the Commissioners are to put in and operate an independent plant for the general supply of gas to the residents, "the rate which may be charged therefor to be not in excess of 10 per cent. over the cost of production and distribution." The bill

also appropriates \$1,000,000 for the promotion of the objects named. Is it not time that the Washington Gas Light Company ceased to be a mark for such arrows as this? Every session we are treated to a like sortie; but there is some satisfaction in realizing that so far the attacking parties have met with defeat, and there is even greater satisfaction in the belief that as it was with the others so shall it be with this.

ANNUAL MEETING, ROCHESTER, MINN.—At the annual meeting of the Rochester (Minn.) Gas Light Company the following officers were chosen: President, C. H. Myers, of Dubuque, Ia.; Vice-President, Thos. Hennessy, Grand Forks; Secretary and Local Manager, A. T. Stebbins; Treasurer, O. Mulcahy, Grand Forks.

NOTES.—The proprietors of the Kingston (Can.) Gas and Electric Light Companies have agreed upon a plan for consolidation. As soon as the arrangement is perfected a bid of 35 cents per night per arc (2,000-candle power) for all-night lighting will be submitted to the authorities. Under the ruling practice the city pays 30 cents for a midnight service.—President Geo. W. Morris, of the Louisville (Ky.) Gas Company, says that the demand for artificial fuel gas in that city is as yet not up to the expectations of the proprietors.—The proprietors of the Portland (Me.) Gas Light Company have arranged with the special money order agencies of the American Express Company for the collection of gas accounts. The points at which payment may be made are six in number, and were selected with especial reference to the convenience of the consumers. The fees for the service are as follows: On bills of less \$5, five cents; \$5 to \$10, eight cents; \$10 to \$20, ten cents. This plan, which is now in operation in several cities, is rapidly gaining favor.—A correspondent informs us that 109 arcs are in use by the city of Omaha, Neb., and then goes on to say: "In some places gas and electric lamps are burning during the same hours, but they are localities which the inspector has not been able to visit. According as he discovers that the electric lamps illuminate the vicinity he orders the removal of the gas lamps, and from that moment pay for them ceases. Thus far 309 gas lamp have been discontinued. At the rate of \$31 per year, which was the old price, the cost of these lamps for a year would be \$9,579. At the present rate, \$25 per lamp, the cost would be \$7,725. The 109 lamps which supplant the gas lights cost \$18,100.—The Rhode Island House of Representatives, on Wednesday of last week, debated the bill which sought to restrict the gas companies of the State to the manufacture of a gas containing not "more than 10 per cent. in volume of carbonic oxide, or any sulphureted hydrogen." The debate was rather lively, in that it was spiced with a liberal portion of personalities. In the end the bill was "indefinitely postponed."—At the annual meeting of the Chucatanunda Gas Light Company, of Amsterdam, N. Y., no change was made in the executive management. This is not to be wondered at, considering the fact that an 8 per cent. return was made to the shareholders during the twelvemonth.

The Market for Gas Securities.

During the week speculation or investment demand for city gas shares assumed something like activity, if not briskness. Consolidated, on fairly large transactions, moved up sharply, going in the early transactions to 97 $\frac{7}{8}$. From this point it sagged off, but at no time did it go below 97, and to-day's opening transactions (that is, Friday) were made at 97 $\frac{1}{2}$. We look forward to a near crossing of the par line, and with no idea that a long stop will be made at the minimum three-figure quotation.

Other city shares are stronger. In Brooklyn the market appears to be all in favor of the holder, and the tone is undoubtedly in line with still higher prices. The reason for this state of affairs in Brooklyn is to be found in the bald truth that the Edison incandescent lighting supply is a failure, utter and complete. Frugal Brooklyn counts the cost of everything that it uses, and its verdict seems to be that gas is cheaper and better than Edison incandescent electric lighting.

Chicago Trusts are up to 48 $\frac{1}{2}$, and the 50 mark will soon be scored. The Managers of the Company have prepared a plan which will lead it into perfectly safe paths; but as the meeting to fix the thing will be held next Thursday, it may be as well to say nothing about the outcome now. Laclede common is woefully weak, being down to 13. Bay State gas is mending, and we believe that at anything under 25 it is a purchase. Muller sold at auction last week 54 shares of Jersey City gas at 170. Baltimore gas is a trifle stronger, at 49 $\frac{1}{2}$ to 49 $\frac{3}{4}$. A marked feature of the day seems to be the neglect exhibited by investors over bond issues, which, in our judgment, are all too low in quotations. In the meantime it is certain that any gas stock which has something like a reasonable prospect does not have to wait long for a purchaser.

[OFFICIAL REPORT.—REVISED BY THE SECRETARY—CONCLUDED FROM PAGE 521.]

SIXTH ANNUAL MEETING, OHIO GAS LIGHT ASSOCIATION.

HELD AT THE BOODY HOUSE, TOLEDO, OHIO, MARCH 19 AND 20, 1890.

SECOND DAY—MARCH 20—AFTERNOON SESSION.

The President—The next question is: "*What is the average life of a meter in constant use, with ordinary good care?*" I don't think any one need to be afraid of discussing this matter on account of the meter men that are present. I only see one or two just now.

Mr. Hyde—I would like to hear some of the meter men state how long a meter will last.

Mr. Graeff—I understand that Dr. McFadden has a meter in a house near him that was put in when he was a small boy, and he is waiting to see how long it will last, in order to answer your question. (Laughter.)

Dr. McFadden—I am not a member of your Association, and I don't like to impose upon you.

The President—We will be very glad to hear from you.

Mr. McFadden—I have known a dry meter to last 30 years, and if you ask me the average life of a dry meter I should want to know what kind of gas you made; for it depends very much on the quality of the article which passes through it. If your gas is sulphurous, as you all know, you will have corrosive action. We had some meters sent to us for repairs, that were made by a competing house. I went to the party and said, "With this gas you can't get these meters made here, or anywhere else, to last." The trouble was in the character of the gas. It formed a filmy oil which, as the gas moved, spread out like thin soap bubbles and burst, and with that came the oscillation of the light. I think myself that the different qualities of gas that have been made in the last 20 years have affected the life of meters differently. In my earlier days we knew nothing but coal gas, pure and simple. I think meters lasted much longer then. We have had meters come into our "hospital," or repair shop, in which the leathers had become as hard as buckboard. The oil is thoroughly extracted by some drying or dessicating substance in the gas. Some are corroded; and there are various diseases of meters. It would take more than one doctor to classify them all. We, as makers of meters, have not the experience which you gentlemen have, with the use of them. We always recommend that you treat a meter very much like you would a man. Keep him in constant service and he will wear better and last longer and behave more accurately. I know we have what we call lazy Monday, and we hate to go to work on Tuesday, and if we have a lazy Tuesday it seems to grow. Constant use and proper care I should advise for every meter. What the average life to-day of a meter is I could not answer. I have known them to last 30 years—a dry meter. The unfortunate thing for the meter makers is that they last too long.

The Secretary—The patient public are under the impression that Mr. McFadden's advice is being heeded by the gas companies, viz., to keep the meters in constant use night and day.

Dr. McFadden—There are public fallacies as well as public truths.

Mr. Hyde—Mr. McFadden spoke of one meter lasting 30 years. Recently a Glover meter was taken out at Cleveland—no meters have come from England since '61, that is 29 years ago—that was set prior to 1860, and it is good yet, apparently as good as ever, as far as we could see. I may also say that I believe that 15 years would be a fair average.

Dr. McFadden—I would like to ask Mr. Hyde if he thinks the character of the gas has not a very great influence on it?

Mr. Hyde—That has a great deal to do with it.

Mr. Matt—How about the location of the meter?

Mr. Hyde—That has something to do with it. How it is cared for, and all about it.

The President—In discussing the life of a meter, I would call the attention of the Association to the following questions in the question-box:

"If a meter gets gummed and sticks—does not work free—what is the best remedy, without bad results to the meter?"

"Do meters, when out of order, work in favor of or against the gas company?"

"What temperature will a meter work best in, giving best results to all?"

The Secretary—In answer to the second question, I believe it is almost the universal experience that meters, when out of order, register against the gas company.

The President—Our consumers, I think, have an opposite opinion, and

if there is any good ground upon which we can make this answer to that question I think we ought all to have just as much fortification as we can get. I presume each one works in his own way to that end. I hope this question will be discussed thoroughly.

Mr. Graeff—I think the only official record we have in this country is that made by the Massachusetts Commission which gives this answer—the answer made by the Secretary. I think the report showed that the meters worked slightly against the company.

The President—That, of course, is something we can place implicit confidence in.

Dr. McFadden—I think that every State inspection shows that the meter, when out of order, registers in favor of the consumer. There is one thing I would mention. Of course, no gentleman expects to carry his watch beyond 12 months without examination for repairs and cleaning. Meters cannot get that attention. With 30,000 or 40,000 meters in a city, in a large place, they cannot receive that attention which you give to your watch. But for accuracy of registering I don't think there is anything in the world to-day that is measured more accurately than gas. There is not a meter leaves a factory that I know of that does not leave it under a sworn inspection. If any gentleman will place before his mind 1,728 cubic inches, and vary it 2 per cent. above or 2 per cent. below, and place those three blocks before him, I don't think he could select which was the 1,728 inches—the difference is so slight.

Mr. Penn—My experience is that it has been against the gas company all the time. In testing meters, once in a great while you will find one that registers a little bit fast. That is a sure thing. There is one thing I can't understand about meters. We get a new meter and the customer will quit using it and go away for a short time, and when he returns and tries to start it his gas won't work. It is dead. Yet it is comparatively a new meter. I don't see why it should be so. I would like the meter men to explain that. If it was an old meter it would be a different thing.

Mr. McFadden—I would like to know if the meter registered at all after setting.

Mr. Penn—It registered when it was first put in.

Dr. McFadden—In transit meters are liable, as other things, to accident; but it is very rare that we hear of accidents in transit. It is remarkable that so few are injured by transit, but some are. It may be set and started and this injury received in transit may become apparent afterwards. I think it comes back to a question of a deposit upon the valve, evaporation taking place by the non use, it becomes sticky and gummy, and the valve of the meter does not work right, or, if working, it leaks; and just in proportion to that leak so is the loss to the company.

Mr. Persons—The only remedy for a meter in that condition is for the valves to be cleaned. Send it to the shop and have those accustomed to that work do it.

Mr. Penn—Do I understand it is the valve that sticks, or the diaphragm?

Mr. Persons—The valve—a gummy substance forms on its face.

The President—I don't know who proposed the second meter question; but it would seem to be in the mind of the writer of the question that a remedy could be applied apparently without taking the meter away.

Mr. Persons—I think I just answered that question. I don't know of any remedy except to have the meter repaired.

The President—You answered in that way, but I apprehend the writer had an impression there might possibly be another remedy.

Mr. Persons—When you send a man out to repair a meter he usually shakes it first, and if he succeeds in loosening the valve there will be a ridge left on the face of it which would make the valve "rock." It would pass gas and register against the company. It is not safe to do it. It ought to be sent to the shop.

Dr. McFadden—I think one of the important elements in the use of a meter is thorough purification of the gas. Prevention is easier than cure. We all know, for instance, that is, all who have had experience in the management of gas works—at least such was my experience—that gas not well purified is very offensive. Skunks are certainly sweet alongside of it. I have no doubt that if gas was thoroughly purified that meters would last longer and work more accurately.

Mr. Printz—While on the question of meters I would like to ask Mr. Evans if he finds any more trouble with the use of blue gas—that is, do the meters give out any sooner in using blue gas than with the ordinary illuminating gas?

Mr. Evans—I do not think we have any more occasion to repair the meters in using the blue gas than we would with coal gas. During some 8 years' experience in the distribution of fuel gas I knew what it was to have to repair meters, but I think there is no danger to be apprehended

from that direction at all. I know that in passing the unpurified gas as we did at Lynn through meters, it acted upon them very quickly. In fact I have known a meter to be perfectly useless inside of six months.

The President—This question as to temperature has not been brought out. It would involve somewhat the best location for a meter.

Dr. McFadden—In answer to the question of temperature allow me to say this: The same law that applies to the human organism applies to all things in nature. We doctors speak very frequently of the vicissitudes of temperature and their influence upon the human organism. Every gas man knows, and my gas experience taught me, that we might run a retort to the melting point without its cracking or leaking, but we could not afford to freeze it without breaking it. Now, meters should not be placed where hot steam would strike them. It has an injurious influence. It contracts the diaphragm, and extracts the oil; and I should say this, that every man is best in an even temperature. He don't want a change of 20° degrees in 24 hours, either up or down; and so with meters. The meter should stay at an even temperature. The best location is the cellar, away from the heater. So that a medium temperature for man or meter, is a good thing.

The President—The 9th question is, "*Is not illuminating gas, of the requisite candle power, sold at a reduced price for fuel, the true solution of the fuel gas problem?*"

Mr. Graeff—This is a question that will take about 5 years more to work out.

The President—I don't suppose it will be solved right here. There may perhaps be some views that members might like to express which we would all be glad to hear. If no one has anything to say upon that we will pass to the next question, "*Which is the correct method of tapping mains, on top or at the side?*"

Mr. Printz—I would answer that question by saying tap on the sides, for two reasons. One is that you don't weaken your pipe by a side tap as you do on top. Another is, if there is any stoppage you can clear your pipe easier by having a straight line than running it out and down with an angle.

Mr. Hyde—That is exactly the opposite reason given by our Mr. Heath why he would tap it on top. He taps on top. He would not tap on the side, and if there is any water in the main it doesn't run out on top while it might on the side.

Mr. Evans—Mr. President, I believe the top of the main is the place to tap them. For instance, if tapped on the top, there is always room to swing your service pipe in any direction you wish. If tapped on the side it is rigid.

The Secretary—If a second-hand opinion will be of any interest, I will state that I asked Mr. Felt, the Superintendent of Distribution of the Cincinnati Gas Light and Coke Company, what his opinion was as to this question, and he said it didn't make a particle of difference, according to his experience, whether the main was tapped on top or side. (Laughter.) He said it depended altogether on the depth of the main. If deep, tap on top; if shallow, tap on the side.

Mr. Evans—I have always noticed that they begin to excavate for the service about the same time they dig down for the main, getting the trench all open at the same time, then the workmen take hold of the pipe, pull it around so as to get it in line, and in a great many instances strip off a portion of the thread.

Mr. Printz—I admit there is a freer chance to swing your pipe sideways, but don't you meet with the same difficulty up and down if you tap on top? You have your elbow in there. Now, we don't think of making a tap in the pipe until we have the trench long enough, so that we can drop in a straight edge with a level in it, and get the proper elevation.

The President—To my mind the top of a main is, all things considered, the preferable place. Doubtless there are many instances where convenience might dictate otherwise. I have no doubt that any gentleman here who has had any practical experience in laying service pipes could refer back to his own experience and find examples of both practices. But, as has been stated, it seems to me that the tapping on the top of the main is, on the whole, the more economical plan, and the more convenient, as well as probably removing some difficulties in the way of disturbances. There is a little item of elasticity in the elbow connection that does not exist in the direct side connection. Perhaps that does not account for much.

Mr. Penn—I don't think I could tap on top at all in our town. Our mains are only about 30 inches deep. We could not get under the curbing at all; hence we use the side tap.

A TELEGRAM.

The Secretary—The President has suggested that I now read a tele-

gram received from Mr. Emerson McMillin, whom you yesterday elected to honorary membership. The telegram is as follows:

"To Irvin Butterworth, Secretary Ohio Gas Light Association.—I never accepted an honor with greater appreciation than the honorary membership in the Ohio Gas Light Association. Present my compliments to the President and members, with my sincere regrets that I cannot be present at a meeting of one of the best working Associations in existence.—EMERSON McMILLIN."

The President—There is also a little routine business that should be attended to now. There are three committees to hear from. Is the committee on nominations ready to report?

Mr. Cantine, on behalf of the Committee, reported the following nominations:

For President and Vice-President, Chas. R. Faben, Jr., and N. Wilkiemeyer; *for Secretary*, Irvin Butterworth; *for Treasurer*, O. P. Taylor and Geo. W. McCook.

We also suggest that whichever candidate (Mr. Faben or Mr. Wilkiemeyer) receives the highest vote shall be President, and the other shall be Vice-President. We would suggest the propriety of electing Mr. Butterworth by acclamation, and of voting by ballot for all the other candidates.

Mr. Wilkiemeyer—Allow me to make the suggestion that we cast the unanimous vote of the convention for Mr. Faben as the next President of the Association.

Mr. Cantine—That is a piece of magnanimity on the part of the gentleman making the motion that he will hardly be entitled to exercise.

Mr. Wilkiemeyer—No, sir; I certainly have a good running mate, and I want him to come under the line first.

ELECTION OF OFFICERS.

Mr. Alexander—I move the rules of the Association be suspended and that the Secretary be instructed to cast the ballot for Mr. Faben for President for the ensuing year. (The motion was seconded, put and carried.)

Mr. Graeff—I make the same motion in regard to casting the ballot for Mr. Wilkiemeyer, for Vice President. (The motion was seconded, put and carried.)

On motion the President cast the vote of the Association for Irvin Butterworth for Secretary.

A ballot was then taken for the election of a Treasurer, which resulted in the election of Geo. W. McCook. On motion his election was made unanimous.

REPORT OF COMMITTEE ON PRESIDENT'S ADDRESS.

Mr. Printz, from the Committee on President's Address, made the following report:

The Committee on President's Address have carefully considered the very valuable suggestions offered, and, in as forcible a manner as possible, would ask the members of the Association to carefully read and work out these suggestions, in the course of the year, to the very best results.

One suggestion in particular should be acted upon at once—*i. e.*, as to the Legislative Committee. This Committee should have definite instructions. It should closely look after all interests appertaining to the welfare of the gas industry, and give its attention to difficulties as they come up, and as they are brought before it. The expenses which this Committee may incur in the fulfillment of its duties should be paid by the Treasurer out of the funds of the Association. As to the scope of its powers the Committee alone should be the judge.

Respectfully submitted, EUGENE PRINTZ, }
H. WILKIEMEYER, } Committee.

Mr. Matt—I move that the report of the Committee be accepted and made a matter of record.

The President—Gentlemen, the report of the Committee is before you for your adoption or rejection, and I trust you will give it as careful consideration as the circumstances may permit. Are there any remarks?

Mr. Printz—Mr. President, Mr. Foote is here. He has given this matter considerable attention, and I would like him to make such remarks as he may feel disposed respecting this question.

The President—I think, perhaps, we had better dispose of the other matter first.

Mr. Printz—I think the information he would give us would probably assist us in determining what disposition we should make of this matter.

Mr. Wilkiemeyer—I think it would be best to discuss this question somewhat. It may be possible that we do not see the need of this Legislative Committee. Now, if we are better informed as to our needs, we may come to some definite conclusion. It is something that requires

thought, and then as we understand each other, the different members of the Association will know what best to do. I think Mr. Foote could give us a very good idea of this subject.

The President—A motion is before the house, but the vote thereon may be foregone, if there are no objections. As I said before, I had a desire to listen to Mr. Foote, and am glad to see him present. Mr. Foote, as you all know, is Chairman of the Committee on Legislation, of the National Electric Light Association. If there are no objections to deferring the vote upon this question, we will defer it, and I will invite Mr. Foote to make some remarks upon the subject of municipal control.

Mr. Rood—The motion before the house seems to be to receive the Committee's report and place it on file. This does not prevent us from afterwards taking up that report and discussing any recommendations they may make. It seems to me that it would be entirely proper to receive the report and then hear from Mr. Foote, or any other gentleman, upon the recommendations of the Committee.

On motion the report of the Committee was received and placed on file.

Mr. Foote, on invitation of the President, then made the following remarks :

Mr. President and Gentlemen:—Perhaps I can serve you best by offering an outline of my connection with this subject of legislation. A year ago, at the convention of the National Electric Light Association, the question was discussed of the municipal ownership of electric light plants. As a result of the papers read at that time a resolution was adopted creating what we term the "National Committee on Legislation," of which I was made Chairman. No instructions were given to that Committee. I was authorized to appoint one member for each State in making up the National Committee. The first object in view was to collect from each State all the bills that were offered in the Legislature of the State, and the discussion had on them, with a view of having them ready to be used in any other State. The plan of work as laid out was on this line—that I, as Chairman of the National Committee, should be furnished from each State with copies of all the bills that were introduced in the Legislatures, and the discussions had on them, with the objective point of having them ready to transfer to any other State where a similar question would come up, so that we would not be constantly threshing out the same old straw in the attempt to get at least some of the questions settled. As soon as we commenced to look into the subject we found there was a very great difference in the laws of each State, between the statutes touching the questions governing electric central station companies; that is, the general question of franchises, rights and powers of local councils over the action of the Company; the way of fixing prices; the way of making up contracts, and all these questions. In fact, every question of legislation that affects a central station company is either a question of State or municipal legislation. In order to unify the electric interests so they could work for their State, we instituted a movement to organize State associations. The membership of these State associations is confined exclusively to operating companies, and they are supposed to look after the legislation in their own States, being assisted in their work through the work of the National Committee. There are 10 or 12 of these State associations now organized. There were 10 in February. So far as the policy of having a Committee on Legislation is concerned, I hardly think there can be two questions about it. All this subject of legislation has to be gone through with by every company, more or less, in some phase or other, every year. The experience that is gained is what you might term a by-product that you now let go to waste. A company has a struggle with a local council over a question of renewing a contract, over a question of price, or something of that kind. When that comes up, if they have not the means of laying their hands on the information that had been brought out in similar struggles elsewhere, they are at a disadvantage. These questions occur all through the United States. If the company having a case in hand would make a record of its own case and transmit that record to the Committee on Legislation, in the course of time the chairman of that Committee would be in possession of data and facts and arguments that would meet any case that would come up, because there is a very great similarity in these cases. They follow a certain rut. To give you an illustration: Last Saturday I received a letter from a certain gentleman saying a town meeting had been called to take a vote on establishing a municipal plant, and wanted all the information he could get on the subject. I was able to send that party pamphlets containing the arguments made in four different States on that subject. At the cost of 25 cents for postage I furnished him arguments that would have cost him \$500, if he had to pay for them. They really cost more than that in the first place in attorneys' fees. I simply state that to show you the workings of this Committee. It can

be carried on with very little expense, and to very great advantage. So far as giving instructions to the Committee is concerned, I do not think the Committee need any instructions. I think the general understanding is that the Committee is to take cognizance of all questions that affect your interests in the line of legislation, whether that legislation be municipal or State. Any one of you having a case in hand should report it to the chairman of that Committee and advise, work with and aid him—the State Committee becoming a sort of a Committee on arbitration between each company and its local authorities. That is the outline on which we are working. Of course the work is still in its infancy. We have not accomplished very much, and still we have got sufficient results from it now to know its value.

So far as the question of municipal ownership is concerned I think there is more agitation going on and more work being done in the direction of trying to institute public plants than most of you are aware. All of the professors of political economy, so far as I know, of the universities, are favoring that issue—some to a greater and some to a less degree; but I think they all favor municipal control as a proper economic measure for the people; and, so far as I know, every professor of political economy who favors municipal control also favors free trade.

Last week I received a letter, from the Secretary of the Board of Transportation of New York city, that has in it quite a full detail of that city. They wanted all the data I could give them on the subject of municipal control of electric light plants and gas plants. I judge this information is being collected to favor the ownership of these plants by the municipalities. Of course, you are all aware of the extent of the Nationalist movement in that direction. They have clubs now in almost every State, and in almost every important city in the States. They are devoting their entire work to that line of development. They are making the move now to introduce a petition in the Massachusetts Legislature, with 200,000 signatures, asking for a general law of that State, authorizing the towns to erect gas and electric light plants. They have a petition before Congress to have the District of Columbia authorized to do so. They are working it in Cleveland. They are working the same thing in Minneapolis; and so all over the country that movement is being carried on. It is a very popular movement, of course, among the wage earners and laboring people, and it will spread and have a great deal of influence. I think the best way to meet that question is through State organizations. I believe to-day that the condition of the electric light and gas companies of Massachusetts is in better shape, and that they are better prepared to meet such issues than in any other State in the country, on account of that State Gas Commission; and, personally, I favor the creation of State Gas Commissions and Electric Light Commissions to take control of that subject. I don't know how familiar you may be with the Massachusetts law, but the short of it is that it creates a commission of three men, with a clerk, to devote their entire time to the work. They act as a Board of Arbitration. If there is any dispute between the local company and the local authorities either one can appeal to this Commission as a board of arbitration, and the decision of the board is final. They set themselves against rate competition, and against competition in the business. Where there is one company in a town, and that company is in shape to perform the service in that town, they do not give their permission to any other company to enter into business in that town. That is, in my opinion, a sound economic condition, and I think you could do no better than to institute your committee on legislation, and simply give them general instructions to look after your legislative interests in every detail and every particular. Then you must remember that they can do nothing whatever unless you cooperate with them. If each company in the State should send to the chairman of that Committee every case that is brought against them, every complaint they have to make, and every complaint that is made against them, with the action taken against them, so that the matter can be made a matter of record, so that it can be preserved and used, in the course of time you will have something that is very valuable to you indeed. It will be a record that will be satisfactory to any legislature or any council, or any board of fair-minded business men competent to examine such questions. I am obliged to you for your attention.

Mr. Graeff—Mr. President, I would like to ask Mr. Foote to give us some outline, if he will, of the manner in which these State associations of electric lighting companies work. It is very probable that it will become expedient, in the eyes of this committee of ours, to recommend the formation of some similar association of the gas companies of this State. I would like to ask Mr. Foote to give us an outline of how these State electric light associations work, so that we may be familiar with it in case the question should come up.

Mr. Rood—I would say a State association has been formed of the electric light men in Ohio, and the organization met last week in Col-

umbus. Hence the electric light people operating plants in the State of Ohio, independent of gas companies and with gas companies, have an association and also have a committee to look after legislation. It was brought about because there was legislation proposed before our Legislature that was going to do a very serious injury to electric light companies, if allowed to pass.

Mr. Graeff—Yes; this State association is simply one of the associations formed under this National Committee, of which Mr. Foote is Chairman. There are 10 or 11 others through the country, and I wish Mr. Foote to explain that plan for the benefit of the gas companies.

Mr. Foote—They are all on a uniform basis, as they admit to membership only operating companies. If a gas company is operating an electric light plant, it is admitted to membership. The tendency has been to make the initiation fee very small. It runs from \$5 a year to \$20; I think it would average \$10. To enable a company to become a member of the association an act of the company would be required—a resolution passed by its board of directors—then any member of that company, any officer or regular employee of the company, can represent the company in a meeting of the association. In fact, all the officers and all the employees of the company, if they choose, can attend the meeting; but they would have to designate some one of their number to cast the vote for the company, so that there would be but one vote by each company. To provide for the finances, an assessment is authorized to be made, which varies from one-eighth to one-fourth of one per cent. of the capitalization. In the State of New York, however, that is changed to \$1 on each horse power employed by the company. In case a gas company is a member, the assessment only applies to that part of its investment which it is using in the electric light business. This assessment is subject to the order of the executive committee of the association. So it gives them the means of raising a fund, if they have use for it, without waiting to call a meeting of the association, or without much delay. They can simply have a meeting of the executive committee, order an assessment, and collect the funds. So far as my observation has gone (and I have been present when eight of these associations were organized), there has been no disposition at all to hold back in the matter of finances. A proposition was made in the State of Massachusetts of making the assessment one-eighth of one per cent. Forty companies were represented at the meeting when the organization was effected, and authority was given the executive committee to raise this assessment from one-eighth to one-sixth of one per cent. by people who had not been what might be called workers of the association—showing that it was popular, and not brought about by those who had been instrumental in bringing the association into existence. You will see that varies somewhat from your Ohio Gas Light Association, because you admit members who are not engineers, but manufacturers, and who have interests other than the simple, direct interest of producing gas with profit from a plant. We are now considering a move to bring all these State associations into federation as a National association. That will be our next step, which will be considered during the next six months. We propose to continue the work of organizing State associations until we get a State association in every State, and then probably we will follow the line of the State commissions as being our best protection in the matter of legislation. That matter, however, has not been brought out before the association in any way for public discussion.

Mr. Rood—In what respect do the laws of Connecticut and Massachusetts differ?

Mr. Foote—Well, I can't answer you technically. Massachusetts has control of the companies through a commission which gives each company protection in its town against any infringement from an outside company—what we call "raiding companies." If I am rightly informed, in Connecticut any body of people can go to its Legislature and get a charter to do business.

Mr. Rood—A charter would have to be gotten through the Legislature instead of the State officers.

Mr. Foote—Yes, sir; I think so. I have a copy of the law under which the Massachusetts State law is operated which I could read, that would give you full outline of the points that we are talking about.

Mr. Evans—I would like to ask Mr. Foote if this power given the Gas Commission of Massachusetts to prevent the introduction of any other company into a city where one is already doing business has not been very recently conferred on them. I was not aware they had any such power.

Mr. Foote—The Act creating this Commission was passed in '85, I believe, and it has been amended several times. I can't tell whether this power was conferred by the original Act or whether it is an amendment; but it gives them supervisory power.

Mr. Evans—I was aware they had considerable power over the gas companies, some of which is a little expensive to the companies. For instance, every gas company there is obliged to keep its accounts according to the form devised by the Gas Commission. They must show in detail on these accounts every pound of coal and every gallon of oil they use, every pound of coke they sell; in fact, every expense in detail must be shown, including the salaries of their officers and the dividends. It makes public the company's business all over the State. All you have to do is simply to get a report of this Commission, which anybody can get by writing for it. I have written for it myself and received it. So that it not only makes your business public throughout the State, but all over the country, for that matter. I understood their power consisted only in obliging companies to manufacture their gas within certain limits, as to a certain per cent. of carbonic oxide that was allowed, a certain amount of sulphur and ammonia, and a certain standard of illumination.

Mr. Foote—I think that 90 per cent. of the companies in Massachusetts, if asked to-day, would say that the Gas Commission is a very great benefit to their business, and they would prefer to see it continued rather than discontinued. That is the information I have from those in that State whom I have come in contact with.

Mr. McDonald—I think, Mr. Chairman, that Mr. Evans is slightly mistaken. The matter he speaks of in regard to carbonic oxide, ammonia and sulphur, are matters of law in the State of Massachusetts. They are, possibly, in some measure under the control of the Commission; but these are matters of State law, and were established before the Commission was established. They are now agitating in the Legislature there a law which will permit of more carbonic oxide in the gas made than is now allowed in Massachusetts. I only speak of this to correct this misapprehension which he had in regard to where these limitations came from.

Mr. Graeff—Mr. President, I think that the Massachusetts law originally covered what it covers to-day in regard to the admission of new companies.

Mr. Evans—I don't think so, Mr. Graeff. I had occasion to look up the matter quite thoroughly when I was in Massachusetts.

Mr. Graeff—I know the Commission is popular to-day among the companies of the State, so far as can be gathered from talking with members from all sections of the State. I think Mr. Foote is right in saying that 90 per cent. of the companies would vote for the continuation of the Commission, but I understood that these electric light State associations were simply for the purpose of attending to the matters of legislation, and not for the discussion of all questions, such as our gas Associations discuss. Is that correct, Mr. Foote?

Mr. Foote—No, sir; not strictly. The legislative point is the "exciting cause," but where we create an association, the association is competent to do any business of interest to the companies in the State.

Mr. Evans—I understand that a petition signed by 20 consumers of gas of any town or city presenting this petition to the Gas Commission, claiming that your gas is of inferior quality, or that you are charging too high a price, can be acted on by this Commission, and that this Commission has power to compel you to reduce your rates.

Mr. Foote—That is true; yes, sir; and the record is that the power has never been abused to the disadvantage of the gas company.

The Secretary—Mr. President, I have given this subject no particular thought, but it occurs to me that for our present purposes the adoption of this recommendation that the committee on the President's Address has made, would be sufficient; that is to say, the appointment of a Legislative Committee that will perform such duties as the Committee on President's Address has suggested; and as Mr. Wilkiemeyer, of that Committee, mentioned apart from the report, viz., to take into consideration an association of companies rather than individuals, and make a recommendation at our next meeting, if such a thing is desirable. I think the adoption of such a plan as that would be sufficient for our present needs.

Mr. Rood—I am of the opinion that the adoption of the Committee's report would be a good thing for the Association. I think their report and recommendation are in the right direction, and I move you that we now adopt the Committee's report. (The motion was seconded.)

The President—Gentlemen, it is moved and seconded that we now adopt the Committee's report.

Mr. Hyde—Mr. President, it seems to me that there should be some limit as to the expenses. One question would be, "How much funds have you got, and how much latitude should we give this Committee?" If they are given unlimited authority, of course, we would naturally suppose they would be judicious in expenditure, but it seems to me there ought to be some understanding, some suggestion, as to the amount of

money that should be expended in carrying out this purpose. Now, it seems to me that it would be well for this Association to investigate and appoint a committee to report at the next meeting; but it does not seem to me they should have authority to attend to this matter in a sort of uncertain manner, according to their own judgment. It seems to me it would be all right for them to prepare a plan and recommend it to the next meeting that could be recommended to the gas companies. It seems to me that this business should be done with the gas companies—that there should be an association of gas companies' representatives. We are not strictly gas companies' representatives, only in a sense; but I don't think we should do anything more than to prepare a plan. Let this Committee prepare a plan, and then, when it is arranged, recommend it to our gas companies, and let our gas companies do anything or not, just as they please. I don't care whether they do or not. I have no interest in it. It is for our companies to do it. Whether our company does it or not is of no consequence to me. They don't send me here, and why should I do anything? I expect that is the case with all of you. You are not sent here by them. You might suggest a plan and recommend it to them, and if they say "We will operate under it," that is their business, not ours. That is my view of it.

Mr. Graeff—I think every member of a gas company here, every engineer or manager, has a direct interest in this matter, and I think this resolution is perfectly in order for adoption from that standpoint—looking to the protection of the interests which we have in it. Of course a committee of this character cannot undertake to combat adverse legislation as can a State association formed by the companies themselves. In the first place, that would require an expenditure of money which this Association could not dream of. But our committee can go ahead, as Mr. Hyde says, to perfect (and possibly go a little further than simply laying) plans, and putting them in shape so they can be carried out by the gas companies of the State, or whatever authority chooses to take hold of the matter; but I think the continuance of this Committee would be possibly the best thing this Association has done at this meeting.

The Secretary—Mr. Graeff, don't you think it would be well to limit the amount of expense that this Committee can incur?

Mr. Rood—If you will allow me to suggest, I think you can overcome that difficulty by inserting "subject to the approval of the executive committee" of your Association.

Mr. Foote—In my work I have to spend money and then get it appropriated afterward; so they have a pretty good hold on me. I always bring in a bill for what I spend.

The Secretary—A motion to adopt this report in full is before the house. I move that we amend by inserting the words "subject to the approval of the executive committee," in reference to incurring expense. (The motion was seconded.)

Mr. Rood—Mr. Chairman, as the mover of that motion, I will accept that amendment.

The motion, being then put before the Association, was carried.

Mr. Rood—Mr. Chairman, who are the Committee named?

The President—As I understand the action of the meeting at Mansfield, the Chair was empowered to appoint two members of that Committee, and the President who followed afterward furnished the third member. The third member of this Committee is now already appointed, and it only remains for the present Chair to appoint two other members. The Secretary tells me that that rule was adopted for future action, or until it should be rescinded. In the absence of any objection to that course I will announce two members of the Legislative Committee that are to be appointed by the Chair. They are Mr. A. J. Stull, President Gas Light Company, Sandusky, Ohio, and Mr. H. Wilkiemeyer, Secretary and Superintendent Gas Light and Coke Company, Portsmouth, Ohio. These were both members before, I think are very able men, and as well qualified as any appointees that could be made.

BACK TO THE QUESTION-BOX.

We will now discuss the 11th question:

"Is the Welsbach burner with natural gas a success, and what proportion of the lighting does it do in towns having both natural and artificial gas?"

Mr. Graeff—Mr. President, I think we have a couple of representatives here who can tell us what success the burner has made with natural gas. One of them is Mr. Hunt.

The President—We will be very much pleased to hear from Mr. Hunt.

Mr. Hunt—Mr. President, we are making some progress in Pittsburgh. We have 12 or 14 thousand there in use, all giving fair satisfaction. In Muncie we have about 6,000. In Findlay we have about 1,500, I think. So far they have given very good satisfaction, and we have them in

some smaller places in Ohio where they have got artificial gas. I think the number of Welsbach lamps in use altogether is something like 75,000—that is, on both artificial and natural gas. In the city here we have an exhibit of Welsbach burners consuming natural gas on about four ounces pressure.

Mr. Graeff—What candle power do you consider those lamps as giving, and how long will they keep that candle power?

Mr. Hunt—I think that candle power is not less than 35, and the lamps will last not less than 750 hours, and will maintain that candle power not less than 250 hours; at no time dropping down to less than 25 or 28-candle power.

Mr. Graeff—How many have you at Indianapolis, do you know?

Mr. Hunt—I think about 6,500 now. The business has reached such proportions there that Mr. Fletcher has expressed himself as interested in the plant, and I think has made some sort of a proposition for us to join in interest with him, or take some part in the business.

Mr. Graeff—Mr. President, I would like to ask Mr. Hunt what is the standing of this light in Mr. Fletcher's estimation? I understand Mr. Fletcher made an offer of \$20,000 for the right of the Welsbach lamp for Indianapolis. Is that correct, or can you answer the question?

Mr. Hunt—Those are secrets; but Col. Barrows wrote me some time ago, when a question came up as to the success of the Welsbach light, as to whether there was any possibility of doing business in Toledo. I explained the business to him, whereupon he said the business had reached the point in Indianapolis that Mr. Fletcher had offered them a handsome sum of money for an interest in it. Mr. Graeff's figures are not far out of the way. We have been working like heroes to introduce the Welsbach, and are meeting with very gratifying success.

The Secretary—How much longer do your lamps last with artificial gas than with natural gas?

Mr. Hunt—With the uniform pressure of natural gas I think the life is about the same. I made that statement, applying it to both natural and artificial gas. In Findlay, where we have a pressure varying from 8 to 20 ounces, the mantles last 500 hours. We get pressures there all the way from 8 ounces to 10 pounds.

The Secretary—How many Welsbach burners did you say you had in Pittsburgh?

Mr. Hunt—There are about 14,000 in use, I think, now.

The Secretary—How many employees are necessary to keep those in order?

Mr. Hunt—Well, I think a force of about 8 to 12 men, including the bookkeepers.

Mr. Rood—At Findlay, Mr. Hunt, what has been the position of the Welsbach burner as compared with incandescent light? Are you displacing the incandescent, or are both the Welsbach and incandescent lights growing?

Mr. Hunt—At a meeting of the Westinghouse Company in regard to the Allegheny business the statement was made that the Welsbach light was causing them a great deal of trouble and displacing a great many lights.

Mr. Rood—What is the condition at Findlay?

Mr. Hunt—At Findlay the incandescent people have made the price as low as 33½ cents for not less than 12 lights, and there they have procured some business.

Mr. Rood—How many incandescent lights have they there, probably?

Mr. Hunt—Not over 250 altogether. Their arc lighting business is a very handsome and profitable one, and increasing all the time.

A Member—Mr. President, I would like to ask Mr. Hunt if the burners are sold to consumers, or whether they are simply rented to them? As I understood, in questioning some consumers, they bought them for so much a burner, and natural gas was furnished by the Welsbach Company—the Welsbach Company supplied the burner, and they were paying for the Welsbach burner 15 cents per lamp per month.

Mr. Hunt—Mr. Stevens, from the Pittsburgh office, can answer that question more intelligently than I.

Mr. Stevens—We have two systems. In Pittsburgh we rent the lamps to our consumers. There are two kinds. Part of them use gas by meter and part of them by contract—we have it so arranged that they can use it through their meter. We have enough to do without it, and they don't pay us for the gas; but, if they are using the meter and wish to rent our light and have us furnish the gas, we will make connection behind the meter and furnish gas, too. To show that it is no "gouge" game with us, I put on, say, 24 lights, and put a meter in the house. We assume that our light will use or consume 1,500 feet of gas in a year. I put on 24 lights, and in a year they burn about 25,500 cubic feet. So that with the use of natural gas such a small amount is hardly taken into consideration.

Mr. Evans—How much does each burner burn?

Mr. Stevens—2½ feet with natural gas. Of course if the gas runs up to a higher pressure I suppose it would use a little more; the average on natural gas is about 3 feet, I think. I have made several tests on different occasions, and found it to run from 2.7 to 3.1—so I always say 3 feet. I also think I am giving a maximum estimate.

Mr. Rood—Do you sell or rent the burners?

Mr. Stevens—In some towns we sell them. In giving contracts to companies we grant them the privilege of renting or selling, as they see fit. The Pittsburgh department is run by our own Company, and therefore we rent the light. In some towns in Ohio the business is run by the Gas Company, and they rent the light. It lies with the company handling the light whether they will rent the burners or sell the light.

Mr. Evans—Is not it a fact, Mr. Stevens, that in Fort Wayne, Ind., they also have adopted that system of renting each burner at 15 cents a month and keep it in order; also that the Welsbach Company furnishes the burner to the consumer, and charges him 15 cents per month per burner, and keeps the burner in order?

Mr. Stevens—Well, I don't understand it that way. I think Mr. Hunt can answer that.

Mr. Hunt—I think the customer makes his own arrangement, paying 35 cents for the mantle, 5 cents for the chimneys, and 20 cents for the shade. The 15 cents is simply for rental.

Mr. Smith—That differs according to localities. In our place they charge 50 to 60 cents. The Company have represented to me that they were the agents.

Mr. Stevens—I would answer that question in this way, where companies take hold they cannot sell the mantle for 35 cents unless they make their rental plan in some way to make it up. The burner cannot be produced for less than that amount of money.

Mr. Rood—What is the price usually charged by the Welsbach Company to gas companies using the burner?

Mr. Stevens—Thirty-five cents. If a company starts out to rent its lights it has to make the rent high enough to cover its percentage on that mantle, because they pay 35 cents for it. They do that in Pittsburgh. That department there (I am not directly connected with it) rent their lights at so much a year. They have a schedule which covers the amount which would give a percentage on the mantle. They furnish the mantle in Pittsburgh for 35 cents, but they are getting a percentage on that mantle in the schedule they make. Where you sell the lamp outright to the company handling the light they furnish the mantles at not less than 50 cents, because it would not pay to handle them for less.

Mr. Rood—As a rule, though, the consumer pays for all the broken mantles or the renewals?

Mr. Stevens—Undoubtedly; you wouldn't expect the Company to buy the material and then give it away to consumers.

Mr. Graeff—Mr. Hunt, at Indianapolis the rental there covers what? Now, I got a schedule that the Indianapolis Company published last month. The schedule ran down, I think, to 50 lights per month, costing \$17.

Mr. Hunt—I think that includes rental of the light and the cost of the gas. I can tell in a moment by looking at the schedule.

Mr. Graeff (reading)—“Per month, 50 lamps, \$17.50.” What does that cover?

Mr. Hunt—That covers the entire cost of the light there. I think they have figured the gas and mantles in that.

Mr. Graeff—I judge, Mr. President, that was an opposition schedule to the electric incandescent.

Mr. Hunt—That is a fact.

Mr. Graeff—I think that has been created to compete with the incandescent electric lamps in wholesale quantities; therefore, that must cover everything. Of course, incandescent electric lighting covers everything, and this must cover everything, including shade and mantle.

Mr. Hunt—Yes, sir; and where there is a uniform pressure mantles last a satisfactory length of time.

The Secretary—I would like to ask Mr. Stevens if, at Findlay or Indianapolis, where a room contains a great number of Welsbach burners consuming natural gas, there is any complaint from unpleasant odors produced by them.

Mr. Stevens—Well, now, I don't know with reference to Findlay. There is a difference, as you all know, in natural gas. At one place we find that the natural gas has an odor, while at another it has none. Mr. Hunt made a statement about the life of a mantle. I believe that the gas in his field (the northwestern part of Ohio) is far harder on the life of our mantle than the gas in the other parts of Ohio and Pennsylvania. In my travels around (and I am “around” pretty nearly all the time),

I find in one field that the mantle will run, on an average, from 1,000 to 2,000 hours. Then I will strike another field where they will not run that length of time. It appears that in this field the gas has more sulphur substance in it. That will eat away the mantle. I found some of this trouble with it in Newark, Ohio, but I overcame that by several manipulations. There the mantles run very well now. The gas is not the same there that it is here—not as hard on the mantles. When I go further I find it still better. I find in some places a natural gas that you can run the mantles on as long as with artificial. I have run mantles for a year without touching them. I can give names of parties who have used them that length of time, and I can also give names of parties who have used them for 2,000 hours. I don't say that our mantle will always run that length of time; but it has run that length of time. It is a delicate thing, of course, and very easily broken. I admit all that; but with judicious management it is a fair estimate to say that the mantle will run 500 hours.

Mr. Rood—What is the shortest time you have known mantles to run?

Mr. Stevens—I have known them to break inside of 10 minutes.

Mr. Evans—What percentage break in 10 minutes?

Mr. Stevens—It would be very small.

Mr. Evans—What I want to get at is the liability to fractures—whether one has to use extraordinary care in handling or lighting them?

Mr. Stevens—Not after they are first started. I consider the mantles should be properly put on. I think a great many mantles are destroyed from not being properly handled, in the first place. To get the best results out of a mantle, I know from long experience that it should be started and tempered slowly at the outset. Then we will get a good result from the mantle. It is a good deal like taking a child and starting it. You have to take it gently at first.

AN INTERJECTION.

The President—I don't want to cut short this discussion, but I believe Mr. Faben is here. Mr. Faben, I would like to inform you of the exceeding satisfaction I have in saying that you have been unanimously elected President of the Ohio Gas Light Association, for the ensuing year.

Mr. Faben—Gentlemen of the Association, I thank you for the honor you have conferred upon me. At such a time it is usually fitting to make some pretty remarks, but we will have to forego that now. The Association heretofore has certainly been a useful organization—a voice: “That is so”—but that its usefulness has been as complete as could have been wished I question. The success of the Association does not depend entirely upon the officers, but does depend upon the individual effort of each member. We all come to the Association meetings. They are well attended. Good subjects are presented. The attendance is here. There is not a member present who has not his ideas and convictions on every subject presented. Yet they are very reticent about placing themselves on record. I do not say these things in a fault-finding sense; but, as your choice for President, I hope at our next meeting all those who have attended this will be present, and will come prepared to render every assistance possible, especially in the way I have suggested, in making the meeting as successful as the one just closing. I thank you again, gentlemen, for this honor.

The President—Gentlemen, are there any further remarks with reference to the Welsbach burner?

The Secretary—Mr. Hunt has called my attention to a letter that Mr. Phillipp, of Findlay, has written me, with reference to the Welsbach burner, which I will read:

“We have been using the Welsbach with natural gas about 14 months, and our satisfaction with it can best be expressed by the following resolution of our Board, passed August 28th, 1889: ‘Resolved, That the general adoption of the Welsbach light be made, owing to its excellence and its economy in the use of gas.’ Also, in the rules and regulations for the use of gas, of January 2d, 1890: ‘The adoption of the Welsbach light for manufacture is recommended by the Board.’ This practical testimony on the part of the Board of Trustees is conclusive to the fact that the Welsbach burner has given entire satisfaction, both as to economy and quality of light. Very truly yours, E. B. PHILIPP,
Sup't City Gas Works, Findlay, O.”

I wanted to say a while ago that as I had already given two or three second-hand opinions, I would also give one on this. A gentleman in Columbus noticed this question on our programme. His occupation is such as to indirectly interest him in gas, but he is not a gas man. He said: “I can answer that question”—he is a man of intelligence and observation—“I have been all over this State and Indiana, and the Welsbach burner, theoretically, is a success, but practically it is not.” That is simply his opinion; it goes for what it is worth. I think myself

that the Welsbach burner is a success, in a measure. It will occupy a certain field, more or less limited, more or less extended.

Mr. Evans—I would like to be made perfectly clear on this matter. As I understand Mr. Stevens the life of a burner is during the consumption of 1,500 feet of gas, and that the mantle is supplied by gas companies at 35 cents apiece. In other words, that 23½ cents represents the carburation of a thousand feet of gas. If I am in error I beg he will correct it.

Mr. Stevens—No; that represents the amount of gas consumed by the light.

Mr. Evans—I so understood it; yes, sir; which represented the life of the lamp.

Mr. Stevens—No, sir; when I spoke about the consumption of gas what I said was that our light would consume in one year 1,500 feet of gas—that is, in ordinary burning, house use. The life of a mantle has nothing to do with the consumption of gas.

Mr. Evans—I thought you had the thing so figured down that you could tell how long a mantle would last by the consumption of gas which was consumed by the burner.

Mr. Stevens—No, sir; you misunderstood me.

Mr. Evans—I think that represents 600 hours.

Mr. Stevens—I made the statement that our mantle would last about 500 hours, but I could produce lots of evidence that it would run 2,200 hours. That does not say that every mantle would run that long—nor can we say that every mantle would positively run about 500 hours; but I do not see any reason why they should not, and where there has been a fair and judicious handling of the light I have not seen a mantle that has burned out in that time. I have not been over this territory, yet, I believe, from what Mr. Hunt has told me about this gas, that it is stronger and has a harder effect upon our mantles than in other places.

Mr. Evans—Can you tell what is the average life of a mantle?

Mr. Stevens—Between 500 and 1,000 hours—700 to 750.

Mr. Evans—Why is it that they vary between 500 and a 1,000?

Mr. Stevens—The Welsbach people have spent several thousand dollars to find that out, and don't know themselves.

Mr. Evans—On the introduction of the burner into use, if you base your prices on that, I don't see how a gas company could figure satisfactorily.

Mr. Stevens—We cannot make any average of that except of the general life of the mantle, which is from 500 to 1,000. Of course, some times they run 2,000, and sometimes they come under 500. But as to the lamps lasting ten minutes, I think not one-half of 1 per cent. is that way.

Mr. Evans—I remember one instance where three out of six had to be removed inside of 20 days.

A Member—I experimented with two, one of which lasted 31 days and the other lasted 22 days. Each burned 4 feet of illuminating coal gas per hour.

The President—What constituted the day, Mr. Evans? How many hours?

Mr. Evans—Twenty-four hours.

Mr. Graeff—I have a dozen of them in my house that were put in there in the fall of '88, and the same dozen mantles are running there yet, with the exception of one which I undertook to run on a test, to see how long it would go without going to pieces. It ran 1,970 odd hours, when some ignorant assistant from the Welsbach Burner Company came up and put a new governor on. He thought that lamp was not looking quite as well as it ought to, and undertook to put another one on. At the expiration of that 1,970 odd hours I could read in the room, which is about 33 feet long, with the light on the opposite bracket. I could read at the extreme corner of the room, certainly 30 feet away from the light. That is what I said a year ago—that the Welsbach burner was a success (and I maintain it is to-day) on artificial gas. I don't know how it is on natural gas.

The Secretary—Mr. Evans, what are the results of any experiments that have been made with the Fahnehjelm comb in connection with the natural gas?

Mr. Evans—I do not think any success has been attained at all. I have made some little experiments, but they gave no satisfaction whatever. In one experiment I made with the Welsbach burner, in burning 4 feet of gas it showed on the photometer 19 candle power when first put on. The first one, at the expiration of 3½ days, showed about 3 candle power; while the other one, which lasted, I think, 22 days, showed between 4 and 5 candle power.

ADJOURNMENT.

Mr. Faux—Before we adjourn I move a vote of thanks be tendered the President for his efficient and courteous services rendered at this meeting. (The motion was put and carried.)

Mr. Hyde—I move a vote of thanks be extended to Mr. Butterworth for his very efficient services. (The motion was put and carried.)

On motion of Mr. Clark the convention adjourned.

Experience with Subsidized Gas Mains.

[A paper read by Mr. Wm. Drewry (Cleethorpes, England), at the March meeting of the Eastern Counties Gas Managers' Association.]

The subject of this paper, happily, is not the every-day experience of gas managers; but there are times when all are more or less liable to subsidences of mains from various causes. In order to give you as clear an idea of my situation as possible, it is necessary to briefly describe the face of the country as it was supposed to be a long time ago, and also its present state.

First, its ancient condition. Cleethorpes was a small village, situated on the east coast of Lincolnshire, on a large clay cliff, one end of which is practically connected with the Wold Hills; far away to the west, the other end jutting far out into the river Humber, and almost directly opposite Spurn Point, on the Yorkshire coast. The next projection we find was Lock Hill, at Grimsby. Whether this was formed in making the old harbor or not does not affect my paper. It lies about three miles northwards. Between these two hills the coast line fell back landwards for a considerable distance, and thus formed a large bay; and a stream (with a gravelly bottom) flowed through it, and there is to be seen to day a sea bank, nearly a mile inland from high-water mark. Time and the action of the wild sea waves have gradually dismantled the beetling cliff, and carried it towards the bay, which, together with sand and gravel, have filled up and brought forward the coast line almost straight with the two points before mentioned—its present state. A road was made across this filled up bay some 40 years ago, from Cleethorpes to Grimsby, and buildings sprang up, by degrees at first, afterwards rapidly.

The Cleethorpes Gas Company was formed for Cleethorpes. Grimsby being at that time almost as far from the new district as Cleethorpes, and being another parish, a race took place between the two rival companies which should get there first, ending, of course, in a lawsuit, resulting in a parliamentary boundary, which meant to each, "thus far shalt thou come, and no farther," and here shall thy Bills be stayed. The name of the district was New Clec, but now it is in the borough of Great Grimsby. The Cleethorpes Gas Company laid a 5-inch main over 2 miles along the Grimsby road, afterwards replacing it by an 8-inch—the one before you. As a proof that I am in the main correct in the description of the country, I do not hesitate to say that there are thousands of houses to-day standing on sea sand, and, of course, gas mains laid in the same; also that water can be seen draining out of the gravel bed and returning to the sea. When the tide is up, it flows inward through the gravel to some extent; and, of course, returns when the tide falls. There are several brickyards, out of whose pits black wood and parts of trees, and, I have been informed, even stags' horns, are sometimes again brought to the light of day. Two years since, it was decided to lay a main sewer along the aforesaid road, and as the Grimsby Tramway Company had previously put down a single line in the center of the road, with numerous switches, it was, unfortunately for us, considered necessary to lay the sewer between the line and our main. In order to avoid the former with its traffic, our main was undermined to a considerable distance; and it was suspended in the most thoughtless manner—in fact, the main was more or less visible all along the road. At the point where the operations commenced, all unknown to us, from the above reasons, the gas supply was placed in the utmost jeopardy. Our solicitor at once wrote to the Board, calling their attention to the danger and responsibility, which had good effect for a while.

All went well until the 8th of August, when the ground subsided some few hundred yards further down the road. (See Fig. 1.) This was over part of the bay before mentioned. It happened in this way: The trench was timbered, but not low enough. The ground was sand and gravel, and the trench made a deal of water, which had to be pumped out before any pipes could be laid, very few of which could be got in at once. By pumping the water and throwing out the loose sloppy sand and gravel, the latter began to purge out from behind the backings as the bottom of the trench was lowered; making still more room for the ground behind the timber to drop, which it did, forcing the boards below the walling until they almost met. I do not think the main dropped then, because it was much nearer the surface than the sewer, and was held up by the timber, which was all right at the top. The pipes were put in as quickly as possible, you may be sure; but the timber was drawn too early—causing the ground to crack on each side and fall in as far as it could, in some instances only very little, in others a

foot and even more. We at once bared the main, when it was found to have subsided, as shown in Fig. 1. Several of the joints were drawn. These were at once stopped temporarily, as we were suspicious of further subsidence. I then had to think of the best means I could to lift the main back to its proper position, as we were almost innocent of the

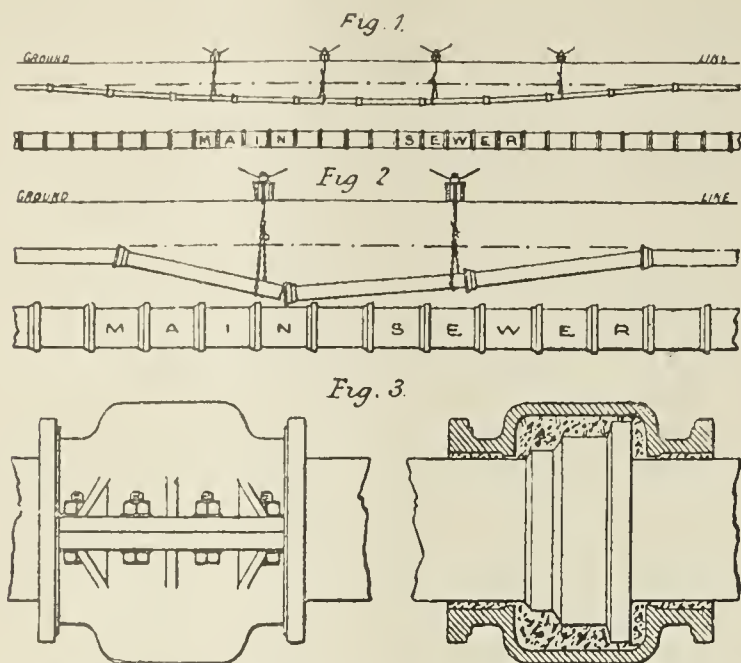

Fig. 1.—Plan Showing a Subsided Gas Main. Fig. 2.—Subsidence and Fracture of a Gas Main. Fig. 3.—Shows Method of Repairing.

same; and I could only turn out my men, some with bottle jacks, some with blocks, and others with that earliest mechanical power of all, the lever, giving the passer-by the impression that the job had been let at random to a marine store dealer, to accomplish in any way he chose, and with anything that first fell to his hand out of his miscellaneous collection. I should mention that it occurred in the height of the Cleethorpes season, and that thousands of people passed daily along the road from all parts of the country. Having several spare retort handles and crossbars, I got four of the T-handles made into hooks and the crossbars into nuts, with two handles (see Figs. 1 and 2). We then got some strong chains, and there being plenty of timber on the spot we placed two planks across the trench (edgeways, as shown), with an iron clasp to prevent them parting, a washer under the nut well oiled, and posted a man at each screw—giving the two in the center orders to slightly tighten their chain and the two outside to keep gently following as they felt their chain slackening. We took care to follow up the main with suitable backings in its upward movement; and fortunately we did, for two chains broke, and, but for that precaution, the last fall would have been worse than the first. After restoring the main to its original position, lead joints were made, and so completed.

Subsidence No. 1.—Another gang of men commenced a mile or so further down the road, and thinking the ground was sound (it looked very good clay), never put in a strut at all, until the walls of the trench showed unmistakable signs of meeting, but luckily left our main in position. Subsidence and fracture No. 2.—On the 17th of August another and more dangerous slip occurred. We lifted the main at once, and found it broken in two. We ran lead joints and temporarily repaired the broken part, and filled up for Sunday, it being close to a switch of the tramway, and interfered with the working of the cars. In truth, that was partly responsible for the mishap. As soon as possible we got a muff (shown in Fig. 3) and placed it in position, built up two clay collars and mouths to a sufficient height, and then poured into one pure Portland cement, rather thin at first and afterwards thicker, until the water and thin cement flowed out of the other mouth, the solid settling at once in the cavity, a hole having been previously drilled in the top of the muff to let out the air and also to watch the cement. After hardening a little the clay collars were removed and the faces trowelled up. A perfectly sound joint was made; and there has not been the slightest escape of gas since, as far as I know.

Conroy's Cut-Off and Relief Apparatus for Gas Mains.

U. S. Letters Patent (No. 424,761) were granted, on April 1st to Jas. C. Conroy, of Pittsburgh, Pa., for improvements in cut-off and relief apparatus for gas mains. According to the specifications the objects of the invention are, first, to provide a simple and convenient means for shutting off gas by control of an electrical circuit or equivalent connection from a line or section of piping, and for relieving the cut-off line

from pressure immediately when the passage in the main is closed; second, to provide means for immediately, if desirable, letting on the gas after it has been cut off, and for closing the escape passage; and third, to provide, in combination with the gas main, an automatic shut-off, an escapement way, and a bye-pass having a valve for closing the escapement-way, and opening said bye-pass; also, in combination with such improved apparatus, to afford facilities for controlling the operation of the same from the gas office.

In the drawings Fig. 1 is a side view illustrating an arrangement of pipes, valves and valve operating mechanism in accordance with the invention; Fig. 2 is a longitudinal central section through the pipes and valves; Fig. 3 is a side view of the valve operating mechanism, with dotted lines showing the action thereof; and Fig. 4 is an end view of the same.

Referring to parts, A denotes the gas main or line of pipe through which the gas normally flows; B indicates an escape or relief pipe connected at its lower end with said main and its upper end extending to a suitable position for safely discharging the gas into the air, said upper end being open and covered by a hood or cowl B'; C indicates a bye-pass pipe that connects with the main at opposite sides of the escape pipe, as at C', and centrally with said relief pipe; D indicates a rotating valve or stopcock located at the junction of the relief pipe B with the main A, and having a three-way port therethrough. The normal position of the valve D in the main is, with its straight ports leading directly through and its third port at the bottom, as shown in Fig. 2; E indicates a rotating valve or stopcock located at the junction of the relief pipe B with the bye-pass C and provided with a two-way port. The normal position

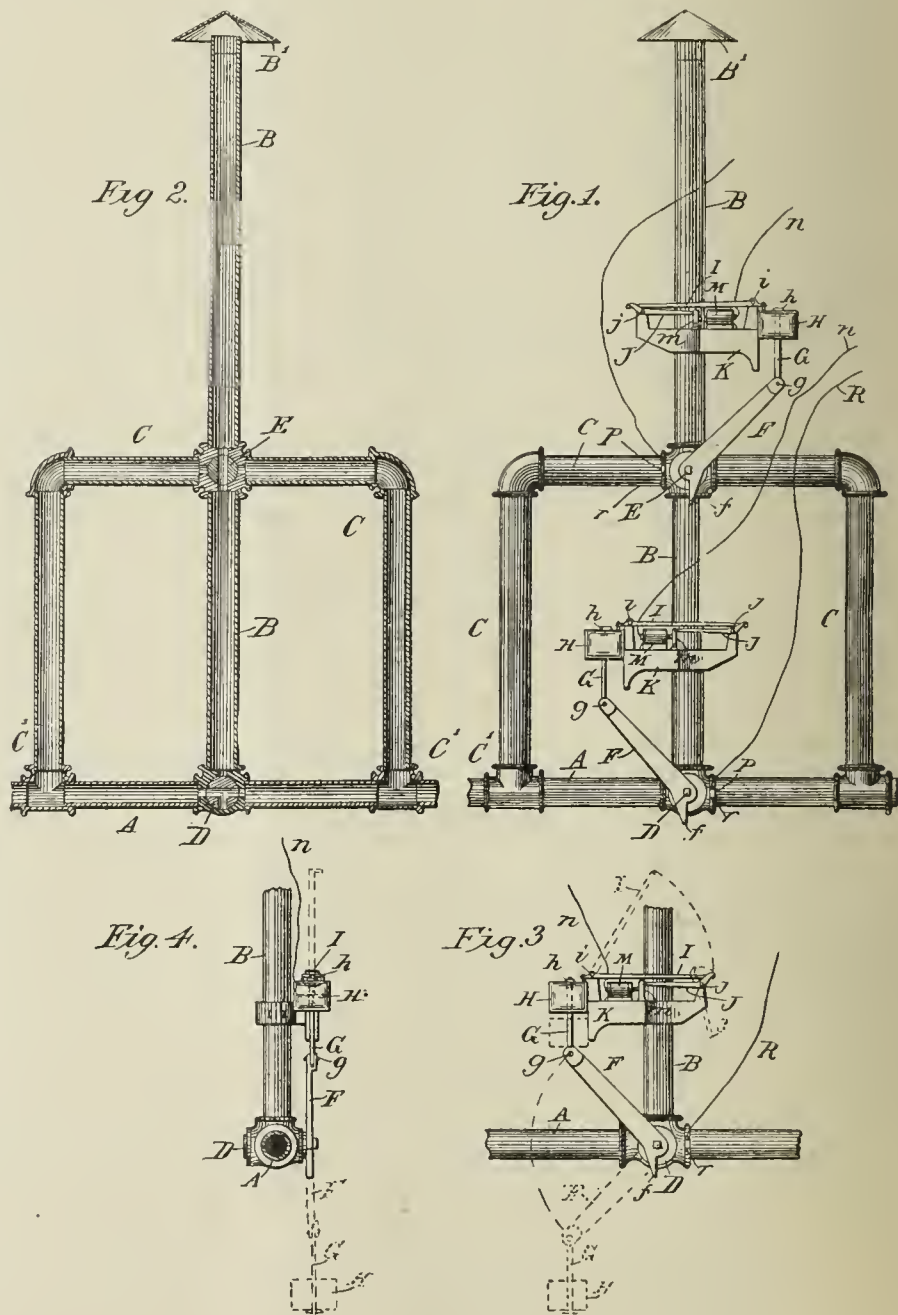

of the valve E is with its port open in line with the relief pipe, or with the bye-pass closed, as shown in Fig. 2.

Any suitably arranged mechanism can be employed for operating the respective valves D and E, but the inventor prefers to employ an automatic mechanism which can be controlled from a central station by electric or other suitable connection, and in the present instance he shows an electrically actuated mechanism arranged substantially as follows: A lever or arm F is attached to the axis of the valve, and to the outer

end of the arm there is connected, by a hinge or pivot *g*, a link *G* that carries a weight *H*. This weight is preferably loose or free to slide on the link, but retained thereon by a head or nut at *h*. Above the arm and supported by a suitable bracket *K* is arranged a trap lever *I*, pivoted or fulcrumed at *i*, and having its shorter arm fitted to engage with a loop or detent on the weight *H* for sustaining said weight elevated, while the opposite end of said trap lever *I* is held down by the escape lever *J*. (See full lines, Figs. 3 and 4.) The lever *J* is fulcrumed at *j*, and is in turn retained by the armature *m* in front of the electro-magnets *M*, which magnets are connected by wire *n* with the central gas office, where suitable batteries and circuit breaking and closing apparatus are combined therewith for sending through the magnets *M* the requisite impulse for moving the armature *m* and releasing the escape lever *J*. In connection with the valve or its operating arm there is provided a lug or finger *f* that comes into contact with a stop or projection *P*, which prevents movement of the valve past the desired position.

The operation is as follows: When the magnet draws back the armature *m* the escapement lever *J*, being thereby released, drops down and allows the trap lever *I* to swing upward and release the weight *H*. (See dotted lines, Fig. 3.) The weight then slides down the link *G* and against the end of the arm *F*, thus giving a stroke to start the valve in case it does not move freely. The link, weight and arm then swing downward, and as the arm descends the link *G* turns over on its hinge *g*, so that the weight can again slide outward thereon and against the head *h*, thus giving a second blow or shock for insuring the complete movement of the valve.

The valve *D* is operated when it is desired to cut off the flow of gas through the main. This instantly closes the main and simultaneously brings one port of the valve into line with the passage of relief pipe *B*, thus giving vent therethrough for relieving the pressure in the section cut off.

When the valve *D* has been closed and it is again desired to let on the gas to the cut off portion of the main, it is done by operating the valve *E*, which valve closes the passage through the escape pipe *B*, and opens the passage through the bye-pass pipe *C*.

The stop-lug *P* is preferably furnished with contact points *r*, from which a wire or wires *R* lead to and connect with an annunciator in the gas office. The finger *f* completes the electric circuit at *r* when the weight *H* falls, and thus sends back a signal to the gas office that the valve has properly operated.

ITEMS OF INTEREST FROM VARIOUS LOCALITIES.

THE sub-committee of the Committee on Manufactures of the Massachusetts Legislature (who are accompanied by Messrs. C. P. Greenough, of Boston, and J. L. Sargent, of Lowell) have been inspecting the various gas works in Virginia that are under municipal control—of course, the inspection was ordered with a view to the acquirement of practical knowledge respecting the degree of success attained by such management, the information to be applied to shaping the policy of Massachusetts in the instance of gas and electric light supply in that State. The Richmond works seem to have interested the committee most, and the inspection there appears to have resulted in the verdict that the plant is well managed; but as gas men are quite well conversant with that fact, they will not be surprised at such an expression of opinion. Another hint, though, in connection with the inspection may be found in the fact that the Mayor of Richmond admitted "that it was more costly to run than a private system would be."

AN explosion occurred recently at the gas works at New Rochelle, N. Y., which cut gas off from the town for an evening or two. Mr. C. C. Van Benschoten, Manager of the works, was slightly injured.

At the annual meeting of the Fulton Municipal (Brooklyn, N. Y.) Gas Company the following Directors were chosen: Benjamin Brewster, H. H. Rogers, Wm. Rockefeller, H. R. Bishop, James Jourdan, E. C. Benedict and J. F. Freeman.

THE new rate at Doylestown, Pa., is \$1.60 per 1,000 cubic feet, with 5 per cent. off for prompt payment. The former gross rate was \$2 per \$1,000.

At the annual meeting of the Rome (N. Y.) Gas Light Company the following result was reached: Trustees, Messrs. G. N. Bissell, J. D. Higgins, Calvin Petrie, T. H. Stryker, E. H. Walworth, H. T. Utley and W. R. Huntington; President, G. N. Bissell; Vice-President, T.

H. Stryker; Secretary and Treasurer, W. R. Huntington; Inspectors of Election, John C. Bissell and Howard E. Ketcham.

No reasonable man can deny that the gas distributed by the proprietors of the Atlantic City (N. J.) Gas Company is as good, in respect to illuminating power, as any gas distributed by any other illuminating gas company in that State. There, however, our commendation of its business methods must cease; for the Company pays no attention whatever to the consumers' burners, which, as a rule, are of the most imperfect sort. In further connection with that forest of hotels (they are all frame structures) we may mention that the incandescent electric light is rapidly losing whatever prior hold it may have had upon the affections of the residents.

THE proprietors of the Malden and Melrose (Mass.) Gas Light Company have decided to construct another gasholder (200,000 cubic feet capacity) on their Malden property.

THE Directors of the Hackensack (N. J.) Gas Light Company have announced the following schedule to take effect on May first:

Monthly Consumption.	Net Rate per M.
5,000 cubic feet and under.....	\$2.50
5,000 cubic feet to 10,000.....	2.25
Over 10,000 cubic feet.....	2.00

WE are indebted to a Troy (N. Y.) correspondent for the following: "Negotiations which have been pending for a week or ten days, looking to a purchase of the Troy and Edison electric light plants operated by the Troy Electric Light Company, by the Troy Gas Company, were concluded on Saturday, April 12, when the agreement and papers of sale were signed in the office of Smith & Parmenter. By the terms entered into by Albert E. Powers, for the Troy Electric Light Company, and A. N. Brady, for the Troy Gas Company, the latter receives, on May 1st, all of the stock in the Company represented by Mr. Powers, paying for the same the sum of \$190,000. The obligations of the Troy Electric Light Company must not exceed \$189,000. Stockholders will suffer loss, as the original plant, independent of the Edison works at the railroad depot, cost \$250,000. The Troy Gas Company by this sweeping purchase obtains a monopoly of the commercial, private and public lighting of Troy and Lansingburgh."

ASSOCIATED Press despatches (dated 14th inst.) brought the news that the plant of the Madrid (Spain) Gas Company was badly damaged through an explosion.

SOME time ago we noted a reduction in gas rates that had been made by the Alton (Ills.) Gas and Electric Light Company, and predicted that President Underwood and Superintendent Tracy would likely be surprised at the gas boom that would ensue when the "folks about town" fully comprehended the liberality of the Company's move. That the prediction was well founded would seem from the following extract from a letter (under date of April 11th) at hand from Superintendent Tracy: " * * *. The reduction in price of gas here has given us more than we can possibly attend to. I have three men connecting meters and gas stoves, and took on eight new consumers last week, and have at least a month's work before me on stoves and new services, with more coming." Well, Mr. Superintendent, we are of the opinion that you won't tire of your activity.

THE City Council of Florence, Ala., has finally agreed to grant to Mr. C. W. Butterworth and associates a franchise for the construction and operation of a gas works at that point. The grantees are to expend at least \$40,000 on the plant, which is to have a capacity equal to the requirements of a city of 25,000 population. The system is to be completed within 6 months. This place is the capital seat of Lauderdale county, Ala., and is on the north bank of the Tennessee river (the latter is spanned here by a substantial bridge), at the head of steamboat navigation, and at the lower end of the Mussell Shoals. It is 70 miles west of Huntsville, and can easily be reached by rail. It is a briskly thriving place, and bids fair to be in a short time a great manufacturing center. Population, about 7,500.

MR. FRANK M. DUNLAP, formerly at Detroit, Mich., has secured a position with the Brunswick (Ga.) Light and Water Company.

A VERY pleasant family reunion was that which was held in Belleville, Ills., on April 7th, on the occasion of the anniversary of the birthday of Mr. John Eimer, President of the Belleville Gas Light and Coke Company.

AT the special meeting of the stockholders of the Louisville (Ky.) Gas Company, convened for the purpose of passing on an amendment to its charter relinquishing its exclusive right to manufacture fuel gas in the city, 9,588 shares were represented, and all favored the adoption of the amendment.

THE Worcester (Mass.) Gas Light Company will build a new retort house on Quinsigamond avenue, that city. The structure will be 102 by 68 ft., and 43 ft. in height. Messrs. Pellet Brothers are to do the mason work.

GALESBURG, Ills., "points with pride" to its \$1.50 gas rate. So it should.

THE proprietors of the White Plains (N. Y.) Gas Company and of the White Plains Electric Light Company have agreed to consolidate their forces under the corporate title of the White Plains Gas Light Company.

THE St. Thomas (Ont.) Gas Company has bargained with the Westinghouse Company for an incandescent electric lighting plant rated to a capacity of 750 lamps of 16-candle power each. The Company's service rate will be 1 cent per hour per light.

THE use of gas for purposes other than illuminating is rapidly spreading in the Eastern States. Mr. Hallett's paper on what he did at Springfield in this line is bearing fruit.

FROM the annual report of General Wagner, Director of the Department of Public Works, Philadelphia, Pa., we make the following extracts in respect to his mention of the workings of the Gas Bureau: The output was 52,980,000 cubic feet less than in the previous year, but this reduction was not caused by reduced consumption, the quantity sold and paid for, as well as the quantity sold for which bills are not yet due, being greater than ever before. An increase of 39,877,914 cubic feet, or over 1 per cent. of the whole output, sold to consumers, and a decrease of 92,858,514 cubic feet, or nearly 2½ per cent., in leakage, and in the consumption of gas furnished the city free of cost, produce large figures when they enter into the receipts and expenditures. The figures are increased still more by reason of the increased production of gas per pound of coal carbonized, amounting to 7,548,500 cubic feet. When, in addition to this, the report shows that 5,241 new meters, and 10,076 new services were introduced last year, that 113,474 lights were added, and that the number of gas consumers is 128,867, it can be reasonably inferred that the days for the use of gas manufactured by the Department of Public Works of the city of Philadelphia are not yet numbered. If it is claimed that some of the gas falls below the standard it is only necessary to state that all the gas stations are connected by large mains, and that no portion of the city can be supplied exclusively with gas from any particular works. When the works passed under the control of this department it was found that they were deficient in all that constituted first-class works of a construction suitable to make good gas and at the lowest prices. Labor saving machinery had never been introduced, and but two stacks with modern appliances for carbonizing coal had been built. The men numbered 2,257, and the cost for skilled and unskilled labor, especially for the latter, was startling. The manufacturing capacity was insufficient to meet the demand at the period of greatest consumption, and the pipes and mains were totally inadequate to distribute the gas made. In fact the works were short of everything but men. At the close of a little more than two years of the new management, by the introduction of labor-saving machinery, the rebuilding of old stacks with benches of 6's instead of 3's, and with the modern "regenerative" furnaces and appliances, and by the introduction of water gas, the manufacturing capacity has been increased from 13,000,000 to 20,000,000 cubic feet in 24 hours; the holder capacity has been increased from 12,000,000 to nearly 15,000,000 cubic feet; and greater length of pipe and mains, especially the latter of large size, were laid than ever before in the same period of time.

Appended is a table showing the maximum daily capacity of the works, as follows: Ninth Ward, 6,600,000 cubic feet; Twenty-first Ward, 200,000 cubic feet; Twenty-fifth Ward, 4,000,000 cubic feet; and Twenty-sixth Ward, 4,300,000 cubic feet—a daily total capacity of 15,100,000 cubic feet. This does not include the plant of the Philadelphia Gas Improvement Company. Fourteen thousand three hundred and thirty-three meters and 26,924 new services have been introduced, the Director said, and the number of lights and of consumers has been increased from 1,886,599 to 2,206,013 of the former, and from 114,386 to 128,867 of the latter. The number of men employed has been reduced from 2,257 to 1,518 during the same period. All the expenses of the works, including extensions amounting to \$506,312.58, and which would have been

charged to capital account in any manufacturing establishment, were paid out of the current receipts, and a balance of \$1,435,796.16 of actual cash remains in the city treasury. Because of the improvements already made, and of others contemplated and under contract, the results of the past two years are but a slight indication of the profits to accrue to the city from her gas works in the immediate future.

The most important event of the year, and perhaps in the history of the Philadelphia gas works, was the completion of the water gas plant, of which a detailed report was made a year ago. The buildings and machinery were finished and gas was delivered as agreed upon, the first passing into the city's holders on January 22d, 1889. The total quantity purchased during the year was 919,647,000 cubic feet, reducing the output of coal gas to 2,231,507,000 cubic feet; total output, 3,151,156,000 cubic feet. The tests made in the contract prove this gas to be of the standard contracted for, and the mixed gas, produced by its passage into the holders simultaneously with the gas made from coal, gives satisfaction to the consumer. It is but proper to state that very few complaints of the quality of the gas furnished come from those parts of the city in which the largest proportion of this gas is burned. The new 20-inch main under contract to be laid from the Twenty-fifth Ward works to the holder station at Ninth and Diamond streets, and on York street from Ninth street to Ridge avenue, will deliver larger quantities of this gas in the northwestern part of the city. If gas is needed in excess of the quantity named in the contract, "not exceeding 3,000,000 cubic feet per day," this plant can readily be increased to double these figures. It is well also to recollect that the city has the option of purchasing these works at any time. A decrease in the output of coal gas because of the quantity of water gas used caused a reduction of 210,666,305 pounds of coal carbonized.

In commenting on the foregoing facts and figures, showing a condition of the management of the city's gas works which must satisfy any reasonable man that the past year has been not only a year of large profit to the city and of general improvement to the works, but also a year of the manufacture of the best gas ever distributed from these works, a local critic says: "We cannot shut our eyes to the fact that there is a widespread belief that exactly the opposite of all this is the case; that the works are badly managed; that the product is poor and getting worse; and that the whole property had better be sold or given to some one who can do things better than the present official. There are those who contend that the gas furnished is bad, and no matter what the place or the occasion, the burden of their tale is the 'bad gas,' by which they claim the people of our city are being robbed. Where this is the result of personal or political ill-feeling caused by disappointed desires for gain of money or of place, it would be a waste of time to even attempt the effort to convince to the contrary—the story has been told so often that the teller actually believes it true; but, where it is the result of an honest misapprehension of the facts as they are, it is due to the citizen, as well as to the officials of this department, that the truth should be published."

Of the operations of the new Bureau of Lighting the Director reports that during 1889 there were in the city 1,045 electric arc lights, 6,476 gasoline lamps, 380 lamps supplied by the Northern Liberties Gas Company, 10,074 under the Bureau, 50 electric lights under the Board of City Trusts, and 149 lamps under charge of the Bureau of Correction—a total of 26,174, the cost to the city for lighting and maintaining being \$467,652.27.

The lighting by electric arc lights is done under annual contracts with 7 different companies, dividing the city into districts suited to the location and the capacity of the power stations of the several companies. The number of lights at the close of the year was 1,045, maintained at a cost to the city, per lamp per night, of from 55 to 45 cents, with an average cost of 48½ cents. The contracts for 1890 have been made at an average cost of 47¾ cents per lamp per night for an estimate of 1,245 lamps.

The territory lighted by underground wires has not been extended during the year, but the continued satisfactory service rendered in the districts so lighted during the past year proves that there are no insurmountable difficulties in the way of putting electric light wires underground, and they will be so placed whenever ordinances requiring it shall be enacted.

MR. W. ELIOT FETTE and his associates in the management of the Dedham and Hyde Park (Mass.) Gas and Electric Light Company are again to the fore with a practical exposition of their opinion in respect to the policy of selling gas cheaply. The latest exemplification of their belief is shown in the action taken by them on the 15th inst., when it was resolved to reduce the gross rate to \$2.50 from \$3 per 1,000 cubic feet, prompt payment—that is, on or before the 15th of each month—to secure to the user a rebate of 20 per cent. This net rate (which is an

"all round" one) of \$2 per 1,000 is a remarkably liberal one for the locality.

A CORRESPONDENT, writing from Austin, Ills., under date of 12th inst., says: "It looks now as though a new gas works for the town of Cicero, Ills., which includes within its precincts Austin, Oak Park, Ridgeland, Clyde, and some others of Chicago's suburban villages, will be built here this summer. In any event the Globe Light and Heat Company, a branch of the Philadelphia concern of that name, has accepted the last franchise granted them by the Town Board of Trustees; and Mr. Tolles, its Manager, and one of the grantees of the franchise, tells me that some of the pipe is already on the way here. I understand that the Hanlon-Leadley apparatus will be put in here, as the Philadelphia Company controls that process. If anything comes up that I think will interest you in this matter, as the work progresses I will keep you informed.—B."

A THOROUGH working test of the washer recently invented by Mr. N. C. Dye, of Rutland, Vt., is being carried on at the Bay State Company's Boston works. So far, we understand, the results are excellent.

THE Brooklyn Gas Light Company has notified City Works Commissioner Adams that it will accept the proposition of the city to pay only \$19.80 per annum for each gas lamp to be maintained in the Company's district. In the lighting competition for the current year the Company submitted a bid of \$22 per post. This is a square backdown on the part of the Company, and would seem to indicate a trifle of weakness in its management; for the latter certainly ought to have known at the time of the general competition whether or not the supply could be under taken on the basis of the figure now accepted.

It is with the greatest satisfaction that we note that the Sage of Indianapolis is to retain his place as Superintendent of the Company that he has served for years with such great success.

It is refreshing to note that the Youngstown (O.) *Telegram* has just put itself on record in the following remarks: "A New York philanthropist has investigated 560 complaints against gas companies, all charging chicanery or dishonesty, and he reports that he did not find a single instance where a company wilfully sought to defraud. He adds that no other business in the world is conducted on more straightforward principles."

ON and after May 1 the Saratoga (N. Y.) Gas Company's selling rate will be \$2.25 per 1,000, with 5 per cent. off for cash.

A RECENT issue of the Omaha (Neb.) *World-Herald* contains the following: "A Gas Company, which is entirely under control of Omaha men, and known as the Nebraska Gas and Fuel Company, has made a move by which it is proposed to illuminate the streets of the southern portion of the city. Caspar E. Yost, the Vice-President, appeared before the Board of Public Works, and upon his application permission was granted to lay mains in the following streets and alleys: Second street, between Poppleton avenue and Hickory street; Hickory street, between Second avenue and Fourth street; alley between Pine and Hickory, to Fourth street; Pine street, from alley between Woolworth avenue and Williams street; alley between Woolworth avenue and Williams street, from Fourth to Fifth; Fifth street, from alley between Woolworth avenue and Williams street, to Poppleton avenue; Poppleton avenue, from Fifth to Sixth streets; Sixth street, from Poppleton avenue to alley between Pierce and Williams; alley between Pierce and Williams, from Sixth to Tenth streets; Tenth street, from alley between Pierce and Williams, to Pierce street; Pierce street, from Tenth to Eleventh; Eleventh, from Pierce to Williams; and Williams, from Eleventh to Thirteenth streets. The work is to be in accordance with the ordinance dated December, 1888, and to be governed by the rules and inspections of the Board of Public Works. In order that the city may know the work is being performed in a proper manner, Mr. Donovan has been appointed inspector for the city. The Company has recently purchased the old buildings of the Boyd Packing Company, and will at once commence putting the buildings in shape so they may be used as the works for the gas plant, and in the meantime mains will be laid in all the streets and alleys asked for in the above petition."

SOME time ago we noted that Mr. S. B. Conde, the Engineer in charge of construction work on the plant of the "Oxy-Hydrogen Company," of Wilmington, Del., was endeavoring to secure applications from the residents of that city for gas to be supplied from the mains of the "Oxy-Hydrogen Company," when the latter was actually in the field as a competitor of the old Wilmington Coal Gas Light Company. One of

Engineer Conde's appeals takes the form of a circular, and it is so rich in its terms that we think our readers will receive both amusement and instruction from a perusal of it. Mr. Conde says: "After April 15th the Oxy-Hydrogen Company will be prepared to take orders for gas of a superior quality to that now furnished to the citizens at 75 cents per 1,000 feet, net, if promptly paid within 10 days from the time of delivering the bill. The works will be ready for delivering gas next fall, and service connections will be made as fast as the mains of the Company are extended. Mains will be laid first upon the principal streets, and gas takers upon those streets are invited to give early orders, so that we may have some guide in laying the first arrivals of pipe." In the meantime we might say that President Betts, of the old Company, does not seem to be greatly disturbed over the situation, to which he still undoubtedly holds the key.

THE premises No. 239 E. 17th street, this city, were badly damaged by an explosion of illuminating gas on the morning of the 14th inst.

It is reported that the Westinghouse Electric Company, of Pittsburgh, is negotiating for the purchase of the Brush Company's plant and system in Baltimore, Md.

THE McComb (O.) Gas and Fuel Company has been incorporated with a capital of \$50,000.

THE Village Board, of Ilion, N. Y., has received the following bids in response to an invitation for tenders for the public lighting by arc lamps, 2,000-candle power each, to be maintained on a moon table: Thomson-Houston Company, 29 cents per lamp per night; Ilion and Mohawk Electric Light Company, 28½ cents per lamp; Ilion and Mohawk Gas Light Company, 28 cents.

Coal Miners' Strikes and London Fuel Supply.

Engineering, in commenting on the disturbances occasioned by the recent strike of the English coal miners, remarks that the fact that fuel is the chief factor in all manufacturing and industrial enterprise is acknowledged universally, but it was never brought home to the minds of all sections of the community so vividly as during the few days over which the coal miners' strike extended. Within a few hours, comparatively speaking, there was a dearth of fuel, in some industrial centers there was positively a coal famine. Prices went up in London from 3s. to 3s. 4d. a ton in the space of two working days. In some manufacturing districts the advanced prices realized reached 10s. per ton. As a matter of fact coal is so essential in all trades and occupations, and in the economy of social life, that utter stagnation and ruin would result if the supplies were cut off for only a few weeks. The immediate result of the strike was the stoppage of some iron works, where large quantities of coal are consumed; then followed the stoppage of some mills and factories in the textile trades where the tonnage consumed weekly is so great that storage rooms for stocks is not possible. There was something approaching to consternation in connection with some of the large gas works of the country where enormous quantities of coal are needed from day to day at the bare prospect of two or three weeks' strike. Happily all anxiety is over, and industrial England breathes freely again. But the lessons taught are not to be forgotten nor lost sight of by all concerned.

Petroleum in Servia.

The Belgian Minister at Belgrade, in his last report to the Belgian Foreign Office, says that up to the present time no petroleum in a liquid state has been discovered, but the country is exceedingly rich in bituminous schist. The following are the principal places in which it is found: The Department of Pojarevatz by the side of the river Pec, between the villages Zelenik and Lechuitza, stretching towards the villages of Vodkovitch and Kakova Bara, up as far as Snegatine; the Department of Kniajevatz, in the whole of the southwest basin of the Timok, from Sorlingue, near Kniajevatz. Bituminous schist has also been found in Brehatz and Nina, while in the neighborhood of Trgovichte there is a veritable mountain of schist. In the Department of Nisch it is found at Zelachnitza, and it is frequently met with in the Departments of Alexinat and Tchoupria, particularly in the basin of the Montnitza and Vitchevatz, which extends to the north as far as the river Ressava, and to the south as far as Rajagne. In the Department of Valievo it is found in the basin extending from Kaloubara to Ligne. Up to the present no one in Servia has engaged in the business of extracting petroleum from these deposits of schist.



A. M. CALLENDER & CO.,

PROPRIETORS.

EDITOR—JOS. R. THOMAS, C.E.

ASST. EDITOR—T. J. CUNNINGHAM.

MANAGER—C. E. SANDERSON.

PUBLISHED ON EACH MONDAY OF THE YEAR AT
No. 42 Pine Street, New York.

This is a recognized official organ of
LIGHT, HEAT, STEAM, WATER SUPPLY,
VENTILATION, SANITARY IMPROVEMENT,
AND GENERAL SCIENCE

TERMS:

SUBSCRIPTION—Three Dollars per annum, in advance. Single copies, 10 cents.

AGENTS.

NEW YORK.—AMERICAN NEWS CO., 39 and 41 Chambers Street.
PHILADELPHIA.—PRATT & CO., Corner Ninth and Arch Streets.
Germany.—B. WESTERMANN & CO., of New York.

MONDAY, APRIL 21, 1890.

Gas Stocks.

Quotations by Geo. W. Close, Broker and Dealer in Gas Stocks.

16 WALL ST., NEW YORK CITY.

APRIL 21.

All communications will receive particular attention.
The following quotations are based on the par value of \$100 per share.

	Capital.	Par.	Bid	Asked
Consolidated.....	\$35,430,000	100	97 ³ / ₈	97 ¹ / ₂
Central.....	500,000	50	85	95
“ Serip.....	220,000	—	95	100
Equitable.....	4,000,000	100	117	119
“ Bonds.....	1,000,000	—	113	115
Harlem, Bonds.....	170,000	—	—	—
Metropolitan, Bonds....	658,000	—	115	120
Mutual.....	3,500,000	100	109	112
“ Bonds.....	1,500,000	—	100	102
Municipal, Bonds.....	750,000	—	—	—
Northern.....	—	50	—	—
“ Bonds.....	150,000	—	—	100
Standard Gas Co -				
Common Stock.....	5,000,000	100	—	45
Preferred.....	5,000,000	100	84	87
Yonkers.....	—	50	112	—
Richmond Co., S. I.....	346,000	50	—	—
“ Bonds.....	20,000	—	—	—
Gas Co's of Brooklyn.				
Brooklyn.....	2,000,000	25	115	120
Citizens.....	1,200,000	20	68	70
“ S. F. Bonds.....	320,000	1000	100	103
Fulton Municipal.....	3,000,000	100	125	130
“ Bonds.....	300,000	—	100	105
Peoples.....	1,000,000	10	84	88
“ Bonds (5's).....	368,000	—	100	—
“ “ (6's).....	94,000	—	100	—
Metropolitan.....	1,000,000	100	100	104
Nassau.....	1,000,000	25	120	—
“ Cfts.....	700,000	1000	100	102
Williamsburgh.....	1,000,000	50	123	125
“ Bonds.....	1,000,000	—	110	112

Out of Town Gas Companies.

Boston United Gas Co. —				
1st Series S.F. Trust	7,000,000	1000	93	93 ¹ / ₂
2d “ “ “	3,000,000	1000	71	72
Bay State Gas Co. —				
Stock.....	5,000,000	50	23 ¹ / ₂	25
Income Bonds.....	2,000,000	1000	—	—
Buffalo Mutual, N. Y....	750,000	100	90	95
“ Bonds.....	200,000	1000	95	100
Citizens, Newark.....	1,000,000	50	155	160
“ Bonds.....	45,000	—	—	—
Chicago Gas Trust.....	25,000,000	100	48 ¹ / ₄	—
Chicago Gas Light. & Coke Co. —				
G't'd Gold Bonds	7,650,000	100	93 ³ / ₈	93 ⁵ / ₈
Equitable Gas & Fuel Co., Chicago, Bonds	2,000,000	1000	94 ² / ₈	95 ¹ / ₂
People's Gas and Coke Co., Chicago —				
1st Mortgage.....	2,100,000	1000	—	100
2d “ “.....	2,500,000	1000	96	100
Consumers Gas Light Co., Jersey City.....				
Bonds.....	600,000	1000	80	—
Cincinnati G. & C. Co..	6,000,000	100	201	203
Consumers Toronto....	1,000,000	50	190	200
Central, S. F., Cal.....	—	—	80	90
Capital, Sacramento, Cal	—	—	58	—
Consolidated, Balt.....	11,000,000	100	49 ¹ / ₄	49 ³ / ₄
“ Bonds.....	6,400,000	—	107	107 ¹ / ₂
Citizens Gas Lt. Co., Rochester, N. Y.....				
Bonds.....	500,000	—	75	90
Hartford, Conn.....	750,000	25	102	108
Jersey City.....	750,000	20	170	175
Laclede Gas Light Co., St. Louis, Mo. —				
Common Stock....	7,500,000	100	10	16
Preferred “....	2,500,000	100	—	—
Bonds.....	9,034,400	1000	82	—
Louisville, Ky.....	2,570,000	50	125	130
Little Falls, N. Y.....	50,000	100	—	100
“ Bonds.....	25,000	—	100	103
Montreal, Canada.....	2,000,000	100	200	208
Memphis (Tenn.) Gas..	750,000	100	40	—
“ Bonds.....	240,000	100	103	—
New Haven, Conn.....	—	25	200	—
Oakland, Cal.....	—	—	35	35 ¹ / ₂
Peoples, Jersey City... “ “ Bonds..	—	—	60	61
Paterson, N. J.....	—	25	99	102
Rochester, N. Y.....	—	50	99	100
Syracuse, N. Y.....	500,000	25	—	—
San Francisco Gas Co.				
San Francisco, Cal....	10,000,000	100	55 ¹ / ₂	55 ³ / ₄
Washington, D. C.....	2,000,000	20	200	208
Wilmington, Del.. ..	—	50	88	90

Advertisers Index.

	Page
GAS ENGINEERS.	
Jos. R. Thomas, New York City.....	573
Wm. Henry White, New York City.....	579
Wm. Mooney, New York City.....	573
William Gardner, Pittsburgh, Pa.....	573
Fred. Bredel, N. Y. City.....	575
GAS WORKS APPARATUS AND CONSTRUCTION.	
James R. Floyd & Sons, New York City.....	579
Continental Iron Works, Greenpoint, L. I.....	579
Delly & Fowler, Phila., Pa.....	579
Kerr Murray Mfg. Co., Fort Wayne, Ind.....	576
Stacey Mfg. Co., Cincinnati, Ohio.....	579
Bartlett, Hayward & Co., Baltimore, Md.....	577
Morris, Tasker & Co., Limited, Phila., Pa.....	577
Davis & Farnum Mfg. Co., Waltham, Mass.....	576
R. D. Wood & Co., Phila., Pa.....	578
Bouton Foundry Co., Chicago, Ills.....	579
Smith & Sayre Manufacturing Co., New York City.....	578
Fred. Bredel, N. Y. City.....	575
United Gas Improvement Co., Phila., Pa.....	569
National Gas Light and Fuel Co., Chicago, Ills.....	566
Simpkin & Hillyer, Richmond, Va.....	563

GAS AND WATER PIPES.

Gloucester Iron Works, Phila., Pa.....	573
Mellert Foundry and Machine Co., Reading, Pa. (John Fox, Selling Agent, N. Y.).....	573
Ohio Pipe Co., Columbus, Ohio.....	573
M. J. Drummond, New York City.....	573
R. D. Wood & Co., Phila., Pa.....	578
Warren Foundry & Machine Co., New York City.....	573
Donaldson Iron Co., Emaus, Pa.....	573
Dennis Long & Company, Louisville, Ky.....	573

PROCESSES.

National Gas Light and Fuel Co., Chicago, Ills.....	566
Bartlett, Hayward & Co., Baltimore, Md.....	577
Wm. Henry White, N. Y. City.....	579
United Gas Improvement Co., Phila., Pa.....	569
The Fuel Gas and Light Improvement Co., N. Y. City.....	564

INCLINED RETORTS.

Laclede Fire Brick Manuf'g Co., St. Louis, Mo.....	564
--	-----

GASHOLDER TANKS.

W. C. Whyte, New York City.....	566
J. P. Whittier, Brooklyn, N. Y.....	571

GASHOLDER PAINT.

The Government Waterproof Paint Co., Boston, Mass.....	563
--	-----

RETORTS AND FIREBRICK.

J. H. Gautier & Co., Jersey City, N. J.....	574
B. Kreischer & Sons, New York City.....	574
Adam Weher, New York City.....	574
Laclede Fire Brick Manuf'g Co., St. Louis, Mo.....	574
Brooklyn Retort and Fire Brick Works, Brooklyn, N. Y.....	574
Borgner & O'Brien, Phila., Pa.....	574
James Gardner, Jr., Pittsburgh, Pa.....	574
Henry Maurer & Son, New York City.....	575
Chicago Retort and Fire Brick Co., Chicago, Ills.....	574
Baltimore Retort and Fire Brick Co., Baltimore.....	574
Oakhill Gas Retort and Fire Brick Co., St. Louis, Mo.....	574
Boston Fire Brick Works, Boston, Mass.....	574

SCRUBBERS AND CONDENSERS.

G. Shepard Page, New York City.....	568
R. D. Wood & Co., Phila., Pa.....	578

REGENERATIVE FURNACES

Bartlett, Hayward & Co., Baltimore, Md.....	577
Fred. Bredel, New York City.....	575
Chicago Retort and Firebrick Co., Chicago, Ills.....	574
Wm. Henry White, N. Y. City.....	579
J. H. Gautier & Co., Jersey City, N. J.....	575

GAS GOVERNORS.

Connelly & Co., New York City.....	571
Fred. Bredel, N. Y. City.....	575
Friedrich Lux, London, England.....	563

SELF-SEALING MOUTHPIECE DOORS.

Smith & Sayre Mfg. Co., New York City.....	578
--	-----

TAR AND CARBONIC ACID EXTRACTOR.

Geo. Shepard Page, N. Y. City.....	532
------------------------------------	-----

CEMENTS.

C. L. Gerould & Co., Brooklyn, N. Y.....	574
--	-----

GAS ENRICHERS.

Standard Oil Co., Cleveland, Ohio.....	580
--	-----

GAS METERS.

John J. Griffin & Co., Phila., Pa.....	582
American Meter Co., New York and Philadelphia.....	583
The Goodwin Gas Stove and Meter Co., Philadelphia, Pa.....	583
Helme & McIlhenny, Phila., Pa.....	583
D. McDonald & Co. Albany, N. Y.....	583
Nathaniel Tufts, Boston, Mass.....	582
Maryland Meter and Manufacturing Co., Baltimore, Md.....	528
Bell & Jones, Philadelphia, Pa.....	582
Harris Bros. & Co., Philadelphia, Pa.....	582

EXHAUSTERS.

The P. H. & F. M. Roots Co., Connersville, Ind.....	570
Smith & Sayre Manufacturing Co., New York City.....	578
Wilbraham Bros., Philadelphia, Pa.....	571
Connelly & Co., New York City.....	571

GAS COALS.

Penn Gas Coal Co., Phila., Pa.....	581
Perkins & Co., New York City.....	580
Newburgh Orrel Coal Co., Baltimore Md.....	581
Despard Coal Co., Baltimore, Md.....	581
Chesapeake and Ohio R. R. Coal Agency, N. Y. City.....	581
Westmoreland Coal Company, Phila., Pa.....	581
J. & W. Wood, New York City.....	580

CANNEL COALS.

Perkins & Co., New York City.....	580
J. & W. Wood, New York City.....	580

VALVES.

Ludlow Valve Manufacturing Co., Troy, N. Y.....	572
John McLean, New York City.....	572
Chapman Valve Manufacturing Co., Boston, Mass.....	572
R. D. Wood & Co., Phila., Pa.....	578
The P. H. & F. M. Roots Co., Connersville, Ind.....	570

GAS ENGINES.

Schleicher, Schumm & Co., Phila., Pa. 581
 Clerk Gas Engine Co., Phila., Pa. 572
 Van Duzen Gas Engine Co., Cincinnati, Ohio. 572

ENGINES AND BOILERS.

Jarvis Engineering Co., Boston, Mass. 571
 Ball Engine Co., Erie, Pa. 563
 Westinghouse Machine Co., Pittsburgh, Pa. 575

STEAM PUMPS.

Van Duzen & Tift, Cincinnati, Ohio. 563

GAS LAMPS.

G. Shepard Page, New York City. 536
 Welsbach Incandescent Gas Light Co., Phila., Pa. 565
 The Siemens-Lungren Company, Philadelphia, Pa. 565
 Fiske, Coleman & Company, Boston, Mass. 574

PURIFIER SCREENS.

John Cabot, New York City. 572
 Bartlett, Hayward & Co., Baltimore, Md. 572

GAS STOVES.

American Meter Co., New York and Philadelphia. 567
 The Goodwin Gas Stove and Meter Co., Phila., Pa. 548
 George M. Clark & Company, Chicago, Ills. 565
 D. McDonald & Co., Albany, N. Y. 583
 Maryland Meter and Manufacturing Co., Baltimore, Md. 528
 Bell & Jones, Philadelphia, Pa. 582
 Chicago Gas Stove Company, Chicago, Ills. 564

STREET LAMPS.

J. G. Miner, Morrisania, New York City. 563
 Bartlett Street Lamp Man'g Co., New York City. 563

BURNERS.

C. A. Gefroerer, Phila., Pa. 580
 H. W. Rappleye, Philadelphia, Pa. 368

STEAM BLOWER FOR BURNING BREESE.

H. E. Parson, New York City. 572

PURIFYING MATERIAL.

Connelly & Co., New York City. 571
 Friedrich Lux, London, England. 563
 Edgewater Lime Works, Edgewater, N. J. 564

COKE CRUSHER.

C. M. Keller, Columbus, Ind. 581

ELECTRICAL APPARATUS.

Wm. Henry White, N. Y. City. 579

WANTED,

By a New England Gas Company,

A Man to Repair Meters, take Meter Readings, etc.

776-3 Address "H. R.," care this Journal.

Position Wanted

As Superintendent of Works.

Elther Coal or Water Gas.

Address "B. W.,"

774-4 Care this Journal.

FOR SALE,

One Eight-Inch Steam Jet Exhauster.

Kerr Murray make, and one of the best. Address J. B. HOWARD, Supt. Key City Gas Co., Dubuque, Iowa. 776-1f

FOR SALE,

The Ironwork for 11 Benches of 5's, viz.:

Cast Iron Hydraulic Mains, 17 inch diameter, Inside. Dip Pipes, Bridge Pipes, Stand Pipes. Mouthpieces and Lids.

Four Purifiers, 10 by 16 ft., with 10-inch Connections and dry Center Seal.

Four Purifiers, 5½ by 10 ft., with 6-inch Connections and Wet Center Seal.

Valves, 6-inch, 8-inch, and 10-inch.

DAVID MOORE, Treas. Salem Gas Lt. Co.,

770-1f Salem, Mass.

FOR SALE,

The Ironwork for Twelve Benches of 6's, viz.: Cast Iron Hydraulic Main.

7-inch Dip-Pipes, Stand-Pipes, and Bridge-Pipes, complete.

Floyd Mouthpieces and Self-Sealing Lids, 15x26 in.

Lids and Mouthpieces only in use over a year. Will be sold cheap.

ISAAC C. BAXTER,

772-1f Detroit (Mich.) Gas Lt. Co.

FOR SALE.

A Complete Water Gas Plant.

60,000 Cu. Ft. Daily Capacity.

Fully equipped; all the latest improvements; includes Generator, Purifiers, and Holder. Can be removed to any part of the country, and set up at small cost. For further information apply to BRADFORD GAS LT. & HEATING CO., Dunkirk, N. Y.

FRIEDRICH LUX,

Ludwigshafen am Rhein and London.

Lux Mass GAS GOVERNORS, Gas Balance.

Simpkin & Hillyer

RICHMOND, VA.

MANUFACTURERS OF

Gas Works Apparatus

BENCH CASTINGS, CONDENSERS,

Scrubbers, Purifiers, Dry Center Seals,

FOUR-WAY VALVES, GAS VALVES,

SULPHATE OF AMMONIA APPARATUS,

TANKS, ENGINES, BOILERS,

PUMPS, ETC., ETC.

Plans, Specifications and Estimates furnished for new works, or alteration of old works. Correspondence solicited. Works, Newport News, Va.

Bartlett Street Lamp Mfg. Co.

MANUFACTURERS OF

Globe Lamps,

FOR

Streets, Parks, Public Buildings, Railroad Stations, etc.

LAMP POSTS

A Specialty.

Office and Salesroom,

40 & 42 COLLEGE PLACE, - - N. Y. CITY.

Gas Companies and others intending to erect Lamps and Posts will do well to communicate with us.

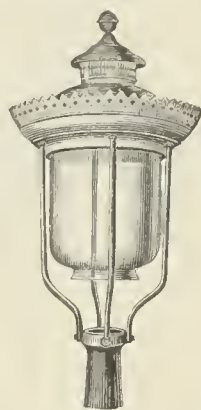
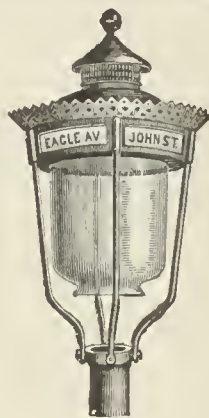
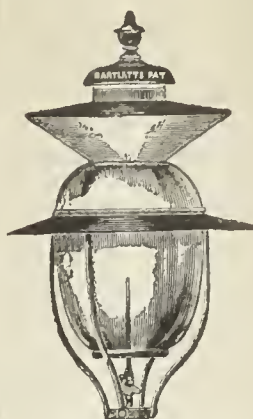

The Miner Street Lamps.

Jacob G. Miner,

No. 823 Eagle Ave., New York, N. Y.

VAN DUZEN'S STEAMJET PUMP

For Water Supply Tanks. For Fire Pump on Yard or Switch Engines. For Round House General Work. For Draining Ponds, Pits, Cofferdams, etc. 10 Sizes. \$7 to \$75. Thousands in use. Write for Descriptive Book to VAN DUZEN & TIFT, 106 E. Second St., CINCINNATI, O.

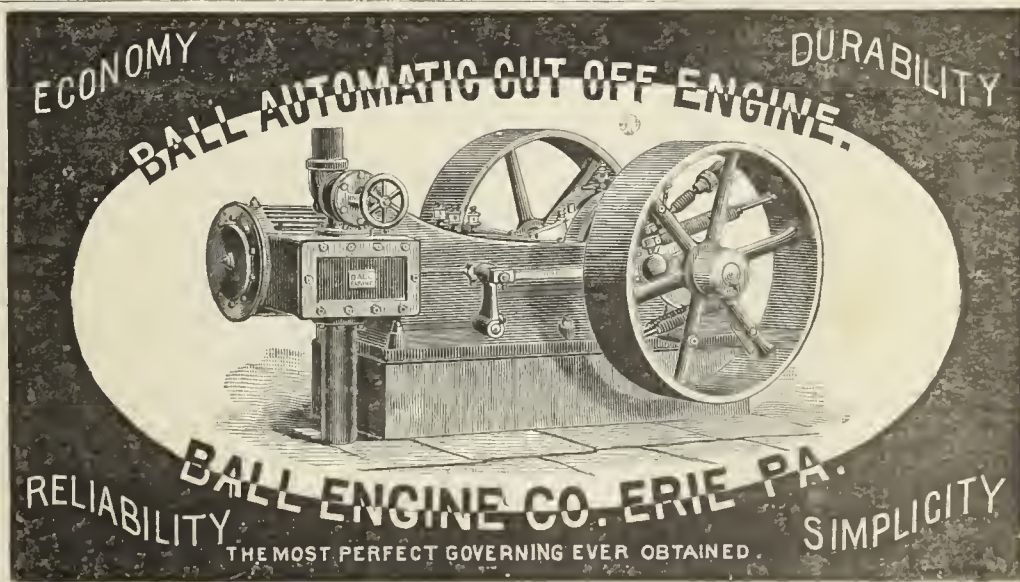

GASHOLDER PAINT.

Use Only

THE GOVERNMENT WATERPROOF PAINT.

Proof against Ammonia, and Absolutely Waterproof. Send for Prices and Particulars.

THE GOVERNMENT WATERPROOF PAINT CO., 122 Milk Street, Boston, Mass.

F. D. HARMON, PRES.

CHAS. C. ALLEN, SEC. AND TREAS.

P. W. MACKENZIE, CHIEF ENGR. & SUPT.

THE FUEL GAS AND LIGHT IMPROVEMENT CO.

OF AMERICA.

Owner of the Mackenzie Patents of Dec. 31, 1889,
For the United States, England, Russia, France, Germany, Austria, and Canada,
No. 32 Park Place, New York City.

This SYSTEM is an ABSOLUTELY NEW DEPARTURE IN THE MANUFACTURE OF FUEL AND ILLUMINATING GAS. The COST OF GAS IN THE HOLDER by our System is at least THIRTY PER CENT. LESS than that made by any other process of the day. The Gas contains neither SULPHUR nor other impurities, nor is there any resultant LAMPBLACK OR TAR RESIDUUM. The Gas is manufactured WHOLLY from LIQUID HYDROCARBONS, such as Lima, Penn. Crude, and Fuel Oils, Naphtha, etc. Neither PERISHABLE PIPES nor other RETORTS, NOR THEIR EQUIVALENTS, are used. The Gas requires NO PURIFICATION. Neither COAL, COKE, nor any other HARD CARBONS enter into the manufacture or composition of the Gas, thereby requiring LESS LABOR THAN ANY OTHER METHOD. The APPARATUS is extremely SIMPLE, SUBSTANTIAL, and DURABLE.

Works under our system can be CONTINUOUS or ALTERNATING. If alternating, the Nitrogen present will be less than 4½ per cent. If continuous, the limited amount of Nitrogen present is neutralized by Carbon.

One gallon of Lima oil by our process EQUALS ALL THE COAL required for making 1,000 feet of carbureted Water Gas.

LACLEDE FIRE BRICK MANUFACTURING COMPANY,

ST. LOUIS, MO.

Exclusive Agents in the United States

FOR THE

Coze System of Inclined Retorts.

IT IS THE COMING BENCH
FOR MAKING COAL GAS.

*It will Save from 50 to
60 per ct. in Labor.*

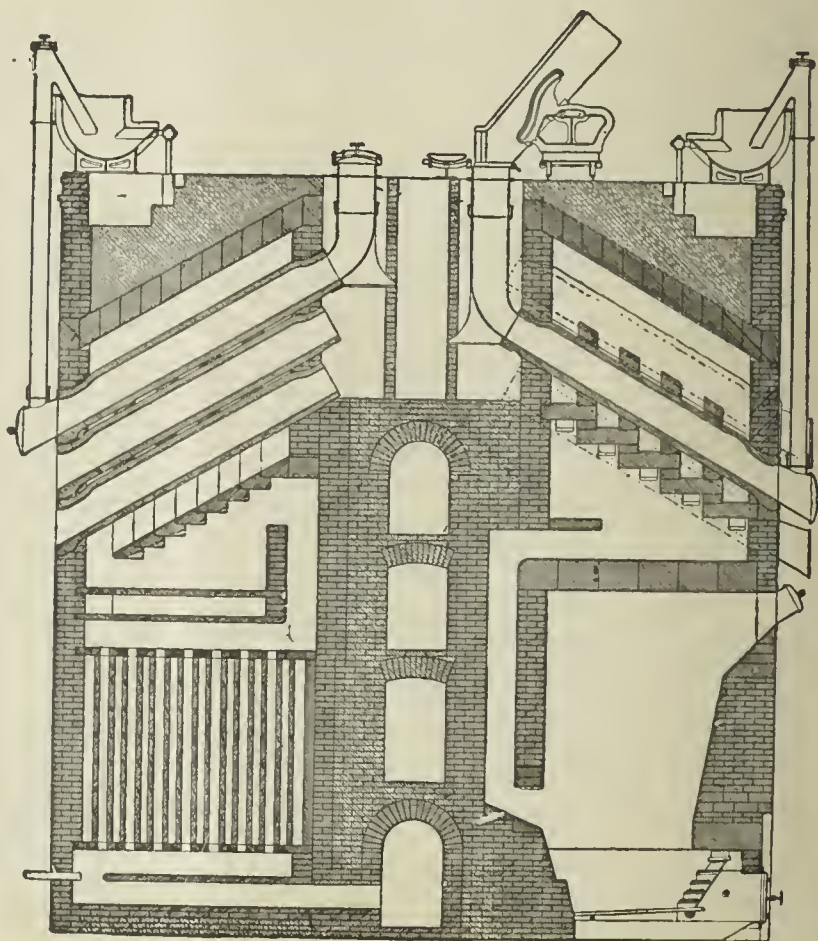
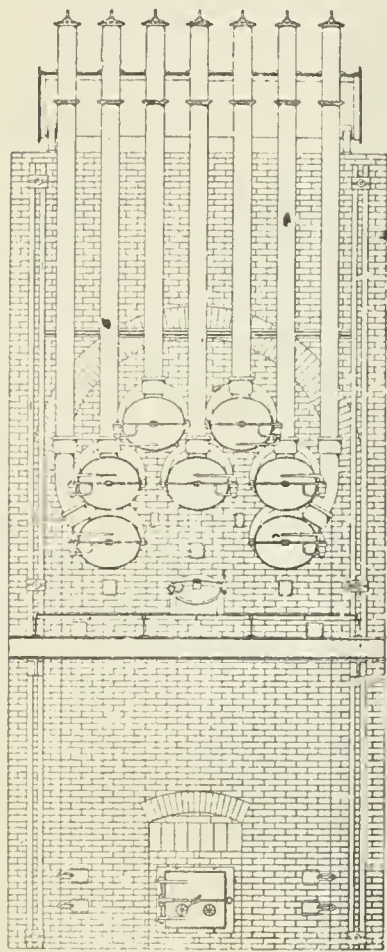

ESTIMATES AND PLANS FURNISHED BY THE

LACLEDE FIRE BRICK MFG. CO., ST. LOUIS, MO.

EDGEWATER LIME WORKS

Chas. F. McKenna, Proprietor.

SHELL LIME.

Lime by the Cargo for Gas Purification.

EDGEWATER, BERGEN CO., N. J.

Write for Testimonials and Prices.

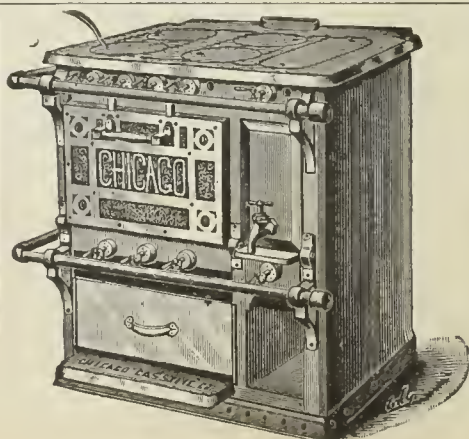

CHICAGO GAS STOVE CO.

MANUFACTURERS OF ALL KINDS OF

Gas Cooking and Heating APPLIANCES.

117-119 Lake St., CHICAGO.

Send for Catalogue.

The Gordon Portico Lamp.

A successful Competitor of the Arc Electric Light for lighting Store Fronts, Show Windows, Depots, Railway Sheds, etc., etc.

The Gordon Street Lamp.

A Successful Competitor of the Arc Electric Light for lighting Streets, etc., etc.

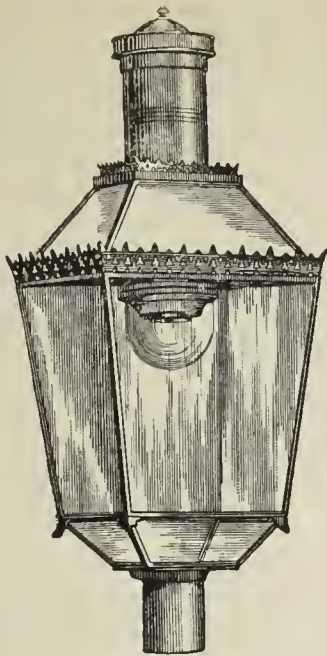

Gordon Street Lamp.

The Lungren Lamp.

A Successful Competitor of the Incandescent Electric Light for Interiors, etc. Is especially applicable for the lighting of Offices, Stores, Factories, Mills, Show Windows, Libraries, and all situations where an increased illumination is desired.

More than 25,000 Lungren Lamps are now in use. Testimonials, references, or any desired information will be cheerfully given.

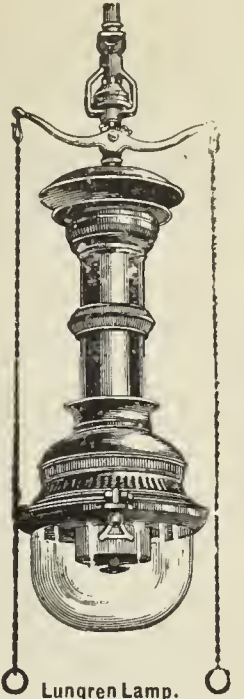

Lungren Lamp.

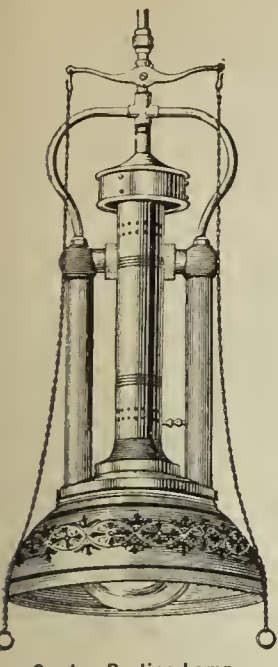

Gordon Portico Lamp.

THE SIEMENS-LUNGREN CO., N.E. Cor. 21st St. & Washington Av., PHILADELPHIA.

WELSBACH SYSTEM OF Incandescent Gas Lighting.

OFFICE, DREXEL BUILDING, PHILA., PA.

At the Fall Session of the Board of Supervisors of Winnebago County, held at the County Court House, Oshkosh, Wis., Nov. 26, 1889, the report submitted by Mr. C. W. Cook, Chairman of the Committee on Public Buildings, recommending the use of the Welsbach Incandescent Gas Burner in the Buildings under their charge, was unanimously adopted, because of the extreme economy in the consumption of Gas and the superior character of the light obtained.

JEWEL GAS STOVES

MANUFACTURED BY

GEORGE M. CLARK & COMPANY,

Nos. 157 & 159 Superior Street, - - - Chicago, Ill.

EVERY CONCEIVABLE SIZE AND STYLE,

Ranging in Prices from \$1.50 to \$30.00.

WE USE NO GAS COCKS.

All Flames are Regulated by a Direct Needle Valve.

The JEWEL

IS THE

Only Well-Made Gas Stove on the Market.

Write for our 1890 Catalogue and see for yourself.

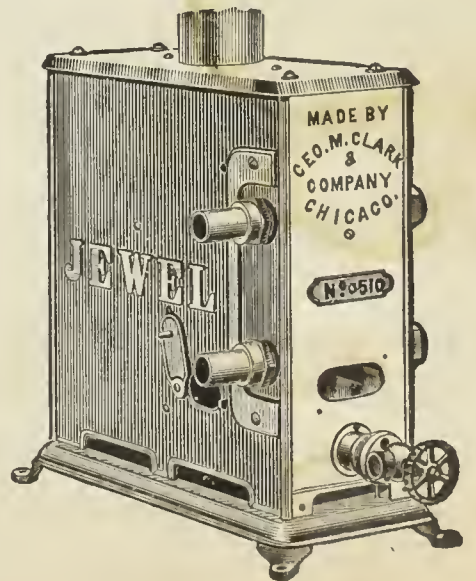
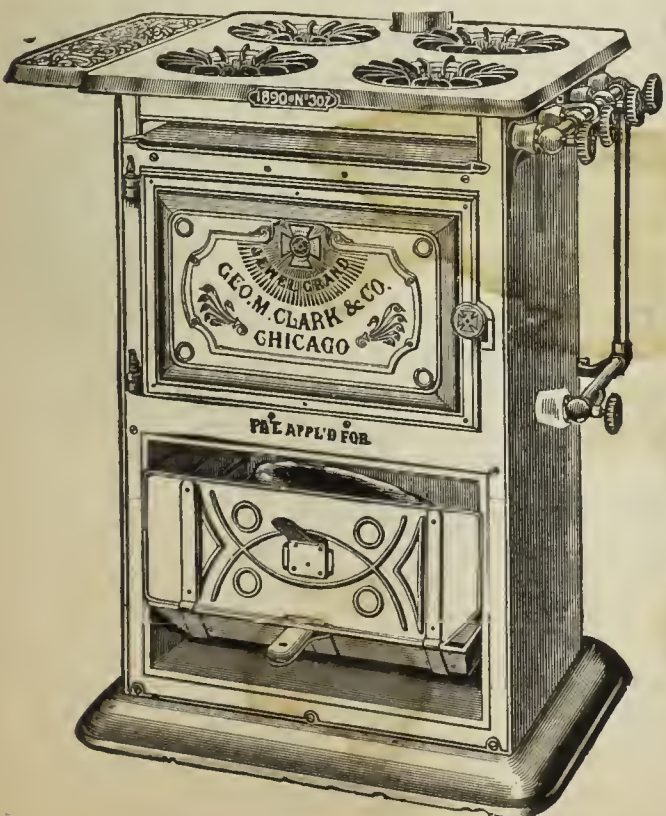

NATIONAL GAS LIGHT AND FUEL CO.,

218 La Salle Street, Chicago.

C. D. HAUK, Prest. & Gen'l Manager.

A. W. GREEN, Vice-Prest.

N. A. McCLARY, Sec. & Treas.

E. E. MORRELL, Engr.

GAS WORKS

Built, Remodeled, Leased, and Purchased.

71 Springer Cupolas have been installed in the U. S. during the past four years.

The total capacity of Springer Apparatus now in use is over 25,000,000 ft. daily.

THE SPRINCER CUPOLA SYSTEM

Has Proven Itself the most Economical and Satisfactory Method of Gas Manufacture ever brought to the attention of the Gas Fraternity.

GUARANTEED ESTIMATES of Cost of Gas Furnished on Application.

GASHOLDER TANK CONSTRUCTION, ETC.

Gas Companies and others about to erect Gasholders will find it profitable to consult W. C. Whyte, who for over 30 years has made a specialty of

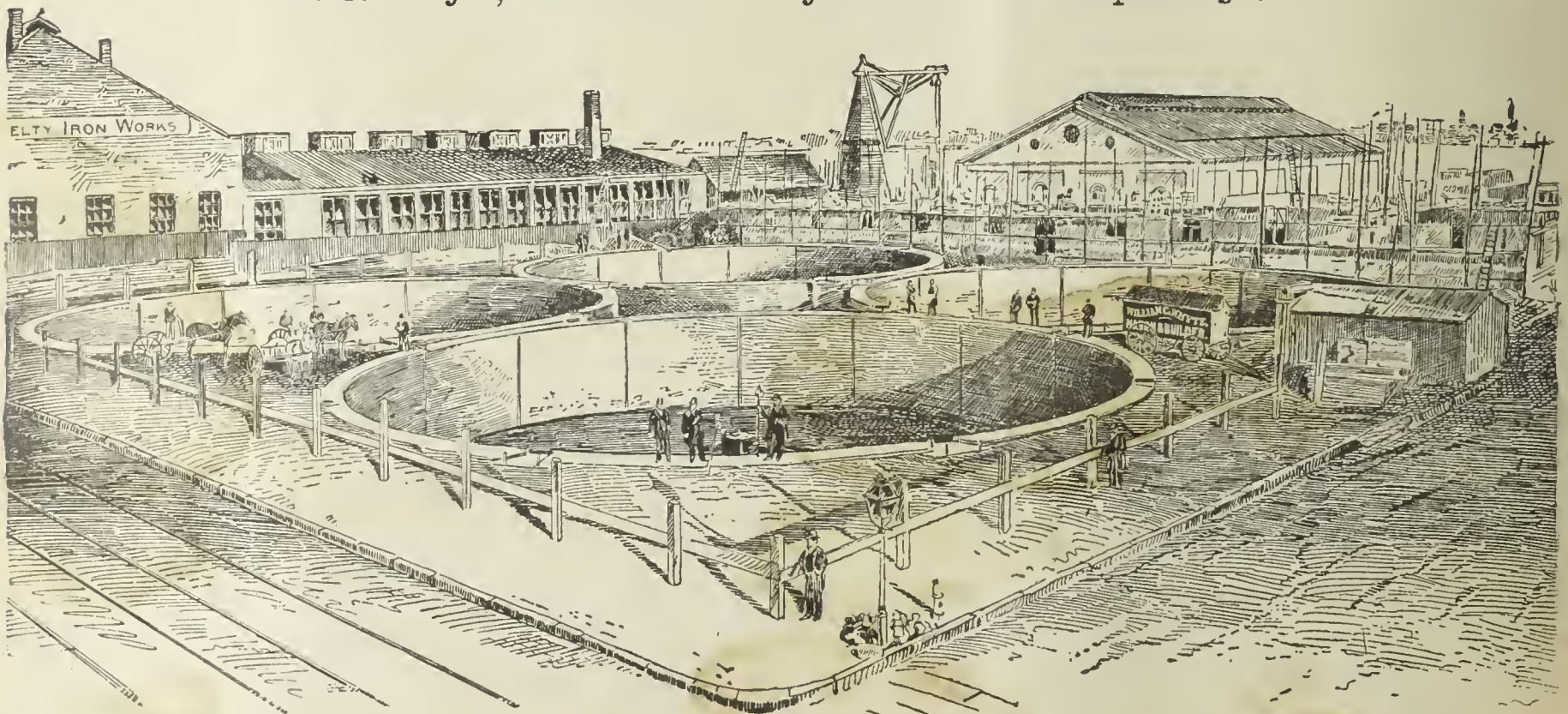

Tank Excavation and Mason Work.

Fifty Tanks now in operation show the sort of work done. Address

W. C. WHYTE, - No. 15 Cortlandt Street, N. Y. City.

GAS STOVES.

GAS METERS.

GAS STOVES.

THE AMERICAN METER CO.,

MANUFACTURERS OF

GAS METERS, Station Meters,

METER PROVERS, PHOTOMETERS,

PRESSURE GAUGES OF ALL KINDS,



Standard 3 Diaphragm Dry Meter

AND

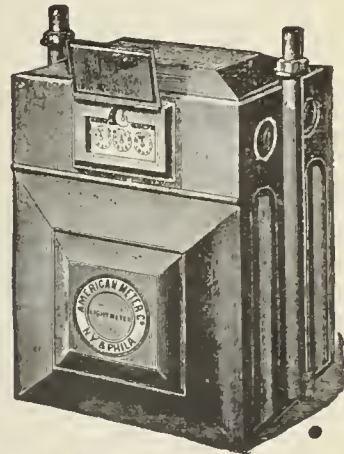

Standard 2 Diaphragm Dry Meter.

Apparatus for Testing the Quantity and Quality of Gases.

GAS STOVES FOR HEATING AND COOKING

Sole Agents in the United States for

Verity's Patent Gas Fires.

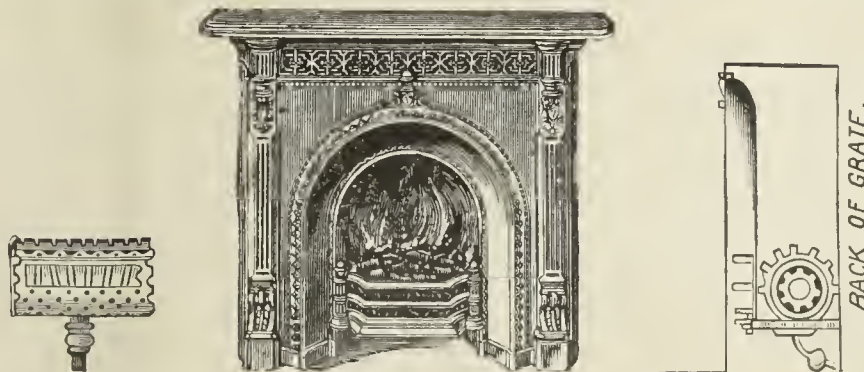

Circulars and Price Lists on Application.

MANUFACTORIES,

508 to 514 West Twenty-second St., N. Y.

Arch and Twenty-second St., Phila.

Nos. 244 & 246 North Wells Street, Chicago, Ill.

AGENCIES,

No. 177 Elm Street, Cincinnati, Ohio.

No. 222 Sutter Street, San Francisco, Cal.

No. 810 North Second Street, St. Louis, Mo.

GAS STOVE SHOW ROOMS, No 242 Sixth Avenue, New York City.

KIRKHAM, HULETT & CHANDLER, LIMITED.

PATENT "STANDARD" WASHER-SCRUBBERS
Erected and in course of construction at present date:

Capacity. Cubic feet per day.	Capacity. Cubic feet per day.	Capacity. Cubic feet per day.	Capacity. Cubic feet per day.
Altrincham..... 600,000	Dublin..... 3,000,000	LONDON—Continued.	Ober Schlesian..... 1,500,000
Adelaide..... 600,000	Dowlais..... 100,000	Shoreditch..... 2,500,000	Otto & Co.'s Coke Works..... 1,500,000
Aldershot..... 200,000	Donai..... 500,000	Pancras..... 1,500,000	Plymouth..... 2,000,000
Allegheny, U. S. A. 1,000,000	Denton..... 500,000	"..... 1,500,000	Parramatta, N. S. W..... 100,000
Ashou-under-Lyne..... 1,250,000	Derby, U.S.A. 350,000	Pimlico..... 2,000,000	Prescott..... 150,000
Amsterdam..... 1,500,000	Denver, " 500,000	Nine Elms..... 3,000,000	Providence, U.S.A. 750,000
"..... 1,500,000	"..... 1,000,000	"..... 3,000,000	"..... 750,000
Annaberg..... 200,000	Dusseldorf..... 750,000	South Metropolitan Co:—	Plauen..... 300,000
Areachon..... 100,000	"..... 500,000	Greenwich..... 3,000,000	"..... 300,000
Animal Charcoal Co..... 200,000	Dumfries..... 250,000	Woolwich..... 400,000	Portsmouth..... 2,500,000
Altoona, U.S.A. 350,000	Dunedin, N.Z..... 400,000	Vauxhall..... 3,000,000	"..... 2,500,000
Buxton..... 250,000	Darlington..... 1,250,000	"..... 3,000,000	Pittsburgh, U.S.A. 1,500,000
Bradford..... 1,000,000	Detroit, U.S.A. 750,000	Lea Bridge..... 300,000	Portland, " 500,000
"..... 1,250,000	Edinburgh..... 1,500,000	West Ham..... 1,500,000	Pawtucket, " 500,000
"..... 1,250,000	"..... 2,000,000	Leeds..... 2,000,000	Quebec 250,000
"..... 1,250,000	Eufield..... 300,000	"..... 3,000,000	Radeliffe..... 750,000
"..... 1,000,000	Essen..... 300,000	"..... 3,000,000	Rouen..... 250,000
"..... 1,000,000	Elbing..... 150,000	"..... 3,000,000	Ramsgate..... 1,000,000
"..... 3,000,000	Falmouth..... 150,000	"..... 3,000,000	Reigate..... 200,000
Bremen..... 150,000	Frankfort..... 300,000	"..... 3,000,000	Richmond, U.S.A. 250,000
Baltimore, U.S.A. 1,000,000	Farnworth..... 400,000	"..... 3,000,000	Roxbury, " 500,000
"..... 1,000,000	Fenton..... 400,000	"..... 3,000,000	Runcorn Soap Co..... 20,000
"..... 1,000,000	Friedenshutte..... 500,000	"..... 2,000,000	Rockhampton, N. S. W..... 125,000
Balmain, N.S.W..... 125,000	Furth..... 400,000	Leominster..... 150,000	Richmond..... 1,500,000
Bishops Stortford..... 150,000	Freiburg..... 200,000	Leiden..... 500,000	Reading..... 2,000,000
Blackpool..... 400,000	Goole..... 250,000	"..... 600,000	Reichenbach..... 200,000
Brussels..... 1,250,000	Glossop..... 300,000	Liverpool..... 2,000,000	Salford..... 1,750,000
"..... 1,250,000	Guildford..... 300,000	"..... 2,000,000	"..... 1,750,000
"..... 750,000	Gloucester..... 1,250,000	"..... 2,000,000	"..... 1,750,000
"..... 1,250,000	Gera..... 300,000	"..... 2,000,000	Smethwick..... 750,000
Banbury..... 250,000	Grafton, N.S.W..... 100,000	"..... 2,000,000	Sydney, N. S. W..... 1,000,000
Birmingham..... 5,000,000	Grieg..... 300,000	"..... 3,000,000	"..... 1,000,000
Birkenhead..... 2,500,000	Georgetown, U.S.A. 250,000	Lincoln..... 1,000,000	"..... 2,500,000
Blackburn..... 1,500,000	Gluckanf..... 200,000	"..... 600,000	"..... 50,000
Bochum..... 600,000	Heywood..... 600,000	Lowell, U. S. A. 1,000,000	"..... 50,000
Burntisland..... 250,000	Hollywood..... 125,000	Louisville " 1,500,000	Sunderland..... 1,500,000
Boston, U.S.A. 2,000,000	Huy..... 70,000	Long Eaton..... 500,000	St. Josephs, U.S.A. 250,000
Brisbaue..... 1,500,000	Harrow..... 250,000	Lilie..... 900,000	Spa..... 100,000
"..... 300,000	Harrogate..... 250,000	"..... 450,000	Sevenoaks..... 300,000
Burton-on-Trent..... 1,500,000	Halstead..... 150,000	"..... 750,000	St. Petersburg..... 2,000,000
Barcelona..... 350,000	Heilbronn..... 200,000	"..... 250,000	"..... 1,500,000
Barking..... 100,000	Havana, Cuba. 750,000	"..... 250,000	St. Louis, U.S.A. 2,000,000
Baerlien & Co..... 20,000	Hastings..... 1,500,000	Luckenwalde..... 330,000	"..... 2,000,000
"..... 20,000	Huddersfield..... 300,000	Liegwitz..... 300,000	"..... 1,000,000
Bombay..... 400,000	"..... 750,000	Lincoln, U. S. A. 250,000	Laclede 1,000,000
Buffalo, U.S.A., Mutual 750,000	"..... 1,500,000	Lawrence " 500,000	Silesian Coal Co..... 600,000
"..... Citizen. 500,000	Hof..... 200,000	Lynn " 300,000	San Francisco, U.S.A. 2,000,000
Brookline, U.S.A. 500,000	Hampton Wick..... 500,000	Lyons..... 1,500,000	"..... 2,000,000
Bergen..... 350,000	Heckmondwicke..... 500,000	Maidstone..... 1,000,000	Sheepbridge Coal Co..... 40,000
Berlin..... 1,250,000	Haverfordwest..... 100,000	Marseilles..... 1,500,000	Stettin..... 200,000
Bournemouth..... 1,000,000	Halifax, N.S. 350,000	"..... 1,500,000	Singapore..... 300,000
Bridgeport, U.S.A. 500,000	Hamm..... 200,000	Mons..... 500,000	Sutton..... 500,000
Brunswick..... 300,000	Halle..... 400,000	Malines..... 250,000	Tonbridge..... 150,000
Beck & Co., St. Louis 100,000	Heidelberg..... 300,000	Melbourne..... 1,500,000	Tiptou..... 400,000
Barmen Rittershausen..... 600,000	Hartford, U.S.A. 1,000,000	"..... 1,500,000	Tottenham..... 1,000,000
Bexhill..... 125,000	Ilkeston..... 300,000	"..... 1,500,000	Toledo, U.S.A. 750,000
Brooklyn, U.S.A. 1,000,000	Inverness..... 250,000	"..... 1,500,000	Toronto 1,000,000
"..... 1,000,000	Ikley..... 200,000	"..... 1,500,000	Uxbridge..... 300,000
"..... Nassau. 1,000,000	Ilford..... 100,000	Manchester..... 2,500,000	Valparaiso 500,000
Brunner, Mond & Co..... 400,000	Kingston-on-Hull..... 400,000	Middleton..... 400,000	West Bromwich..... 1,000,000
Cheltenham..... 2,000,000	Kidderminster..... 750,000	Manley, N. S. W..... 100,000	Willenhall..... 250,000
Cannes..... 200,000	Kidsgrove..... 100,000	Minneapolis, U. S. A. 750,000	Weston-super-Mare..... 500,000
Croydon..... 1,500,000	Konigberg..... 1,000,000	Magdeburg..... 300,000	Waltham..... 150,000
Copenhagen..... 200,000	King's Lynn..... 300,000	Memphis, U. S. A. 750,000	Wormwood Scrubs..... 300,000
Clevedon..... 200,000	LONDON:—	Nottingham..... 1,250,000	Williamsburg, U.S.A. 600,000
Columbus, U.S.A. 500,000	The Gaslight and Coke Co.:	"..... 2,500,000	"..... 600,000
Cincinnati, " 1,500,000	Beckton..... 1,250,000	"..... 2,500,000	Wellington..... 150,000
"..... 1,500,000	"..... 1,250,000	"..... 2,000,000	Warwick..... 300,000
Chicago 3,000,000	"..... 1,250,000	"..... 1,500,000	Wheeling, U.S.A. 500,000
"..... 1,000,000	"..... 1,250,000	Newport, U.S.A. 430,000	Walker..... 300,000
"..... 1,000,000	"..... 1,250,000	Newmarket..... 150,000	Westgate..... 100,000
Chemnitz..... 1,000,000	"..... 1,250,000	Newark, U.S.A. 680,000	Wilmington, U.S.A. 500,000
Crewe..... 1,250,000	"..... 1,250,000	Northfleet..... 200,000	Windsor, N. S. W..... 100,000
Colonial Gas Works Co..... 100,000	"..... 2,500,000	"..... 2,500,000	Wolverton..... 100,000
Cadiz..... 300,000	Silvertown..... 1,000,000	New York, U.S.A. 2,000,000	Wellington, N. Z..... 250,000
Charlotteburg..... 600,000	Bromley..... 2,000,000	Nice..... 600,000	Whitchurch..... 175,000
Dudley..... 750,000	"..... 1,500,000	Newcastle, N. S. W..... 200,000	Washington, U.S.A. 2,000,000
Driffild..... 100,000	"..... 1,500,000	Numea, "..... 100,000	Wallasey..... 750,000
Dukenfield..... 500,000	"..... 1,500,000	Namnr..... 250,000	Weimar..... 150,000
Dover..... 750,000	"..... 1,500,000	Newark..... 350,000	Wurzen..... 200,000
"..... 1,000,000	"..... 2,000,000	Oldbury..... 500,000	Worcester, U.S.A. 750,000
Deal..... 200,000	"..... 1,500,000	Otley..... 200,000	Yeaton..... 500,000
Derby 1,500,000	"..... 1,500,000	Oswestry..... 250,000	Yeovil..... 250,000

SOLE AGENT FOR WESTERN HEMISPHERE,

GEO. SHEPARD PAGE, 69 WALL STREET, NEW YORK.

THE UNITED GAS IMPROVEMENT CO.

Drexel Building,

CHESTNUT AND FIFTH STREETS,

PHILADELPHIA, PA.

OFFICERS:

WILLIAM W. GIBBS, President.

GEORGE PHILLER, Vice-President.

SAM'L T. BODINE, Gen'l Manager.

RANDAL MORGAN, Gen'l Counsel.

EDWARD C. LEE, Sec'y and Treas.

ALEX. C. HUMPHREYS, Gen'l Supt.

WALTON CLARK, Ass't Gen'l Supt.

H. H. EDGERTON, Chem. and Eng'r.

DIRECTORS:

GEORGE PHILLER,

THOMAS DOLAN,

HENRY C. GIBSON,

WM. T. CARTER,

WILLIAM G. WARDEN,

SAM'L T. BODINE.

BUILDERS, LESSEES AND PURCHASERS OF

✻ GAS WORKS. ✻

ROOTS' GAS AND BYE-PASS VALVES.

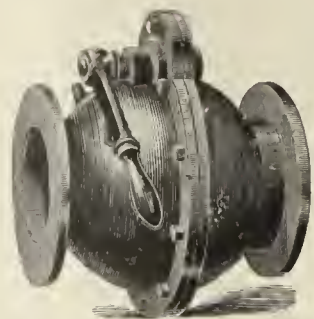

GAS VALVE

Quick Acting,
Simple,
Efficient, Durable.



BYE-PASS VALVE.

Automatic Action
Reliable
Simple, Durable.

Thousands now in use and giving perfect satisfaction. Write for Catalogue and Prices.

ROOTS' NEW GAS EXHAUSTER.

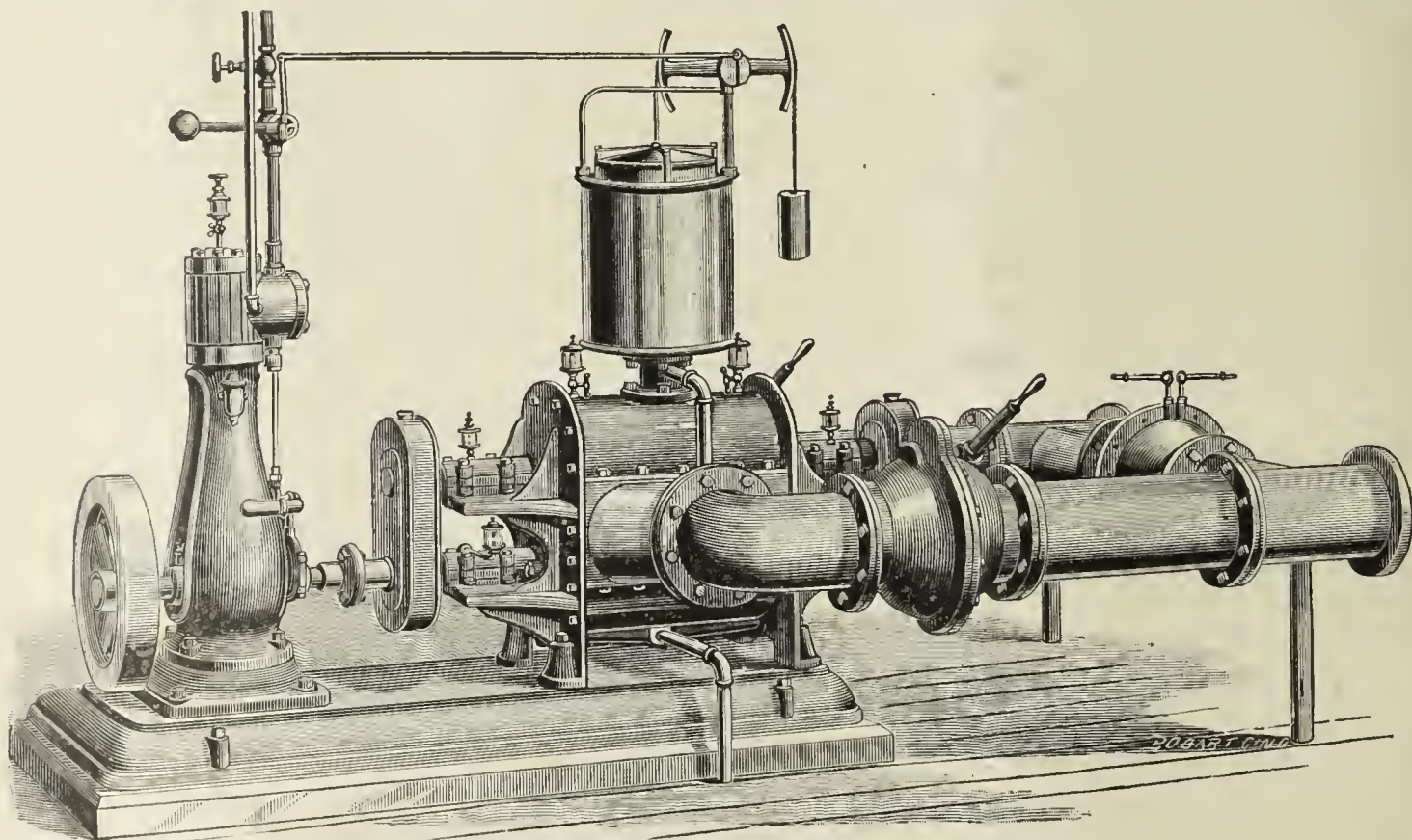

We will take pleasure in furnishing estimates on complete plants, including **GAS EXHAUSTER, ENGINE,** and **GAS GOVERNOR,** all connected, complete, on same bedplate. Also, estimates for **GAS VALVES, BYE-PASS VALVES,** and **PIPE FITTINGS,** arranged in any manner to suit the exhauster room or main connections.

All flanges of pipe and valve fittings faced off, with bolt holes drilled, all ready to go together.

S. S. TOWNSEND, General Agent, } 22 Cortlandt St., N. Y. P. H. & F. M. ROOTS CO., Connerville, Ind.
COOKE & CO., Selling Agents,

CONNELLY & CO.,

SOLE MANUFACTURERS OF THEIR PATENTED SPECIALTIES.

"IRON SPONGE." Saves money, saves labor, and is the most efficient purifying agent ever offered as a substitute for lime. Now used in every State in the Union, and purifying daily over thirty-five million cubic feet. Should be used in every gas works. Its own saving will pay for it many times over.

AUTOMATIC GOVERNOR. Has been on the market but three years, and in that time has been introduced more generally than any invention ever designed for use in gas works. Over two hundred of them now in use. Sensitive; reliable; perfectly automatic; reduces leakage; satisfies consumers, and gives great relief to the Manager. No gas works is complete without one of these machines.

STEAM JET EXHAUSTER. Designed particularly for small works. Combines Exhaust Tube, Steam Governor Gas Compensator, and Bye-Pass Valves in the most compact form possible; occupies but little space; uses very little steam; operated by ordinary workmen; saves formation of carbon in retorts; increases yield 10 to 15 per cent. Specially adapted for mixing air with oil gas. No works too small to use them profitably.

Prices given on all our specialties delivered at any point in the United States. Correspondence solicited.

CONNELLY & CO., No. 111 Broadway, New York City.

WILBRAHAM GAS EXHAUSTER

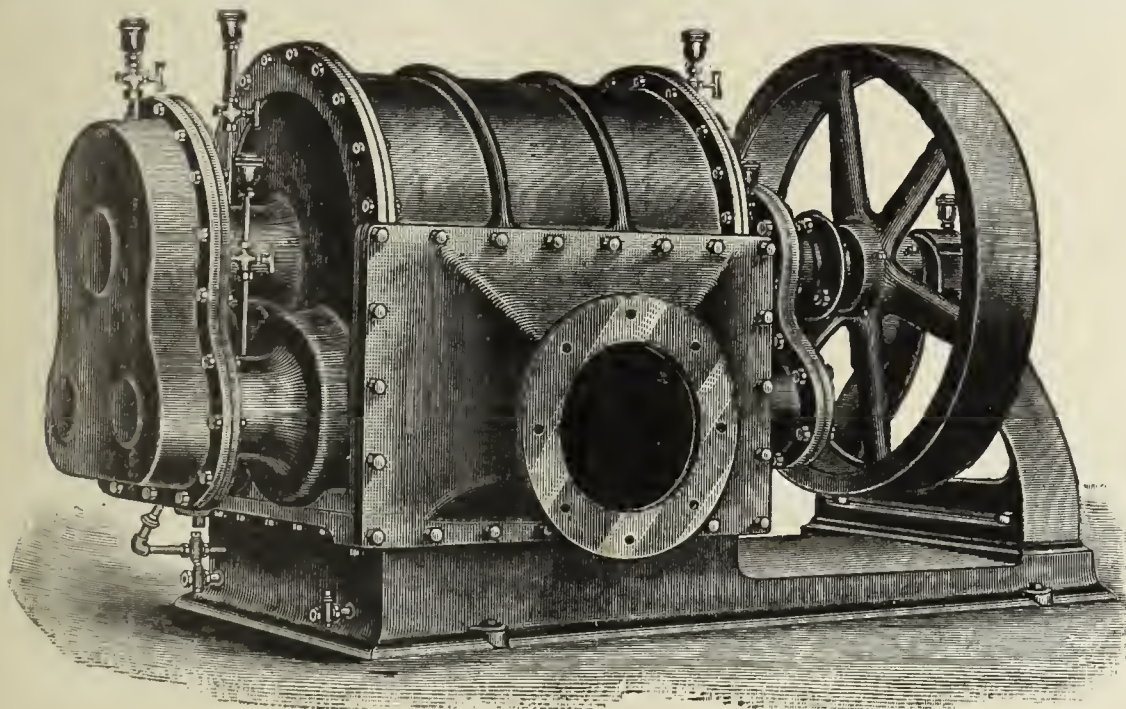

WILBRAHAM BROS.,
PHILADELPHIA, PA.

JARVIS ENGINEERING CO.,

61 Oliver St., Boston, Mass.

CONTRACTORS FOR ERECTING
COMPLETE STEAM OUTFITS FOR ELECTRIC LIGHTING STATIONS.

Steel Boilers set with Jarvis Pat. Boiler Setting

To burn **COKE SCREENINGS** for Fuel.

ARMINGTON & SIMS CO. ENGINES,

Belting direct to Dynamos, without using Shafting.

SEND FOR CIRCULARS.

REFERENCES.—Charlestown Gas & Electric Light Co., Charlestown, Mass.; Schenectady Gas & Electric Light Co., Schenectady N. Y.; Brookline Gas Co., Brookline, Mass.

Practical Electric Lighting

By A. BROMLEY HOLMES, A.M.I.C.E.

With 87 Illustrations. Third Edition. Price, \$1.00.

Electric Light Primer.

By CHARLES L. LEVEY.

A simple and comprehensive Digest of all the most important facts connected with the running of the Dynamo and Electric Lights, with Precautions for Safety, etc.

Price, 50 cents.

A. M. CALLENDER & CO., 42 Pine St., N. Y.

Gasholder Tanks & Gas Works Masonry Complete.

PLANS PREPARED AND ESTIMATES FURNISHED AT SHORT NOTICE.

J. P. WHITTIER, - - 499 Wythe Av., Brooklyn, N. Y.

1889 DIRECTORY 1889

OF THE GAS LIGHT COMPANIES of the UNITED STATES & CANADA.

Price, \$3.00.

A. M. CALLENDER & CO., No. 42 Pine Street, N. Y. City.



CHAPMAN VALVE MANUFACTURING CO.,

MANUFACTURERS OF

Valves and Gates for Gas, Ammonia, Water, Etc.

Also, Gate Fire Hydrants With and Without Independent Nozzle Valve. All Work Guaranteed.

WORKS & GEN'L OFFICE:
Indian Orchard, Mass.

TREASURER'S OFFICE:
72 Kilby & 112 Milk Sts, Boston, Mass.

LUDLOW VALVE MFG. CO.

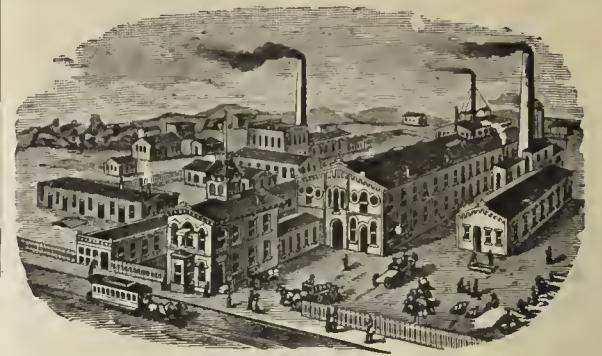

OFFICE AND WORKS,

938 to 954 River Street and 67 to 83 Vall Av.,
TROY, N. Y.

Hydraulic Main Dip Regulators, also
Check Valves, Foot Valves, Yard-
wash and Fire Hydrants.
Send for Circulars.

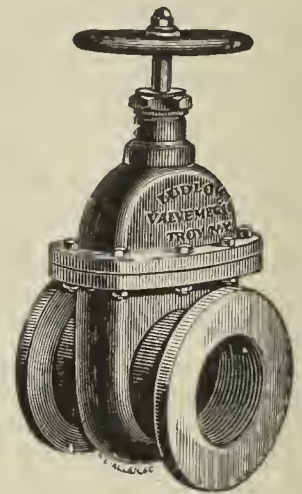

Valves.—Double and Single Gate, 1/2 in. to
48 in., outside and inside Screws. Indica-
tor, etc., for Gas, Water, Steam, and Oil.
Send for Circulars.

Parson's Steam Blower,

FOR IMPROVING BAD DRAUGHT IN BOILERS, AND FOR BURNING BREEZE OR OTHER WASTE MATERIAL.

PARSON'S TAR BURNER,

FOR UTILIZING COAL TAR AS FUEL.

PARSON'S AIR JET TUBE CLEANER,

FOR CLEANING BOILER TUBES.

These devices are all first-class. They will be sent to any responsible party for trial. No sale unless satisfactory. Manufactured by the WATERTOWN STEAM BLOWER COMPANY.

H. E. PARSON. Supt., 33 & 35 Liberty St., N. Y

MILLS' REVERSIBLE LIME TRAY,

AND

WOODWORK

Of Every Description

NEEDED BY GAS WORKS.

SEND FOR CIRCULAR AND PRICE LIST TO

BARTLETT, HAYWARD & CO.,

Pratt and Scott Streets, Baltimore, Md.

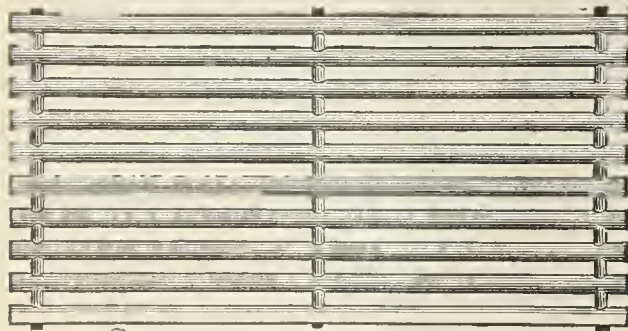

VAN DUZEN GAS & GASOLINE ENGINE

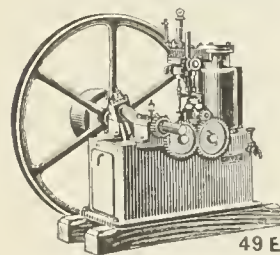

OPERATED with COAL and OTHER MANUFACTURED GASES AND GASOLINE.

RELIABLE AND ECONOMICAL.

Fully Warranted

VAN DUZEN

Gas & Gasoline Engine Co.

49 E. 2d St., Cincinnati, O.

A. MacKinnon Machine Co., Agts., 22 Warren St., N. Y.

The Management of Small Gas Works.

BY C. J. R. HUMPHREYS.

Price, \$1.

Orders to be sent to **A. M. CALLENDER & CO.,**

42 PINE STREET, NEW YORK.

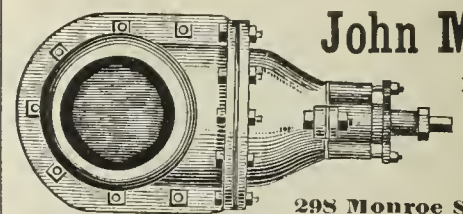

John McLean

Man'facturer

GAS VALVES.

298 Monroe Street, N. Y.

SPECIAL TRAYS FOR IRON SPONGE OR OXIDE OF IRON.

CHURCH'S TRAYS A SPECIALTY.

REVERSIBLE-STRONGEST-MOST DURABLE-MOST EASILY REPAIRED.

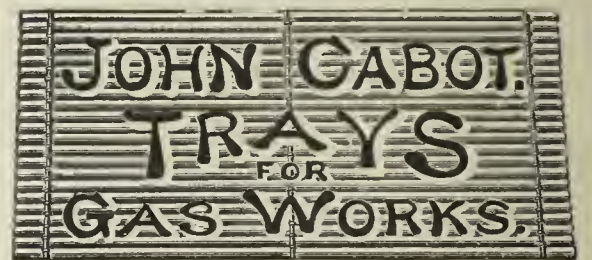

306-310 ELEVENTH AVENUE, NEW YORK.

WE ALSO MAKE THE CHEAPEST AND STRONGEST REVERSIBLE BOLTED TRAYS IN THE MARKET.

THE CLERK GAS ENGINE CO.,

Main Office, 1012, 1014, 1016, 1018 Filbert St., Philadelphia, Pa.

WM. W. GOODWIN, Prest.

E. STEIN, Sec.

S. LEWIS JONES, Asst. Sec.

A. J. DOTY, Supt.

The utility and convenience of the Gas Engine being no longer an open question, it only remains now for intending purchasers to select the BEST. We claim for the CLERK GAS ENGINE that it is equal to any other manufactured as regards steadiness in running, simplicity, and ease of keeping in repair, and that it gives the greatest amount of power for the least money (both in first cost and expense of running) of any engine made. In support of this claim we refer to the test of the Gas Engines made under the direction of the American Institute of New York, in December, 1885, and heretofore published in these columns. These engines are especially adapted for continuous running under heavy loads, and we can refer to Engines which have run 22 hours a day for months at a time.

Made in Sizes of 5 10 15 20, and 25 Horse Power. All Engines Guaranteed for One Year.

ENGINEERS.

GAS AND WATER PIPES.

GAS AND WATER PIPES.

P. D. WANNER, Chairman.
R. B. KINSEY, Secretary.

A. H. MELLERT, Managt. of Wks.
F. A. KNOPP, Treasurer.

SAM'L R. SHIPLEY, Pres.
HENRY B. CHEW, Tre.

JAS. P. MICHELON, Sec.
WM. SEXTON, Supt.

MELLERT FOUNDRY & MACHINE CO. Ltd.
and **READING FOUNDRY CO., Ltd.**
Reading, Pa.

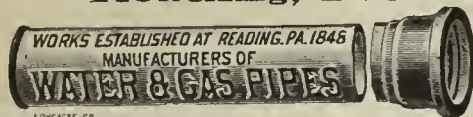

Specials—Flange Pipe, Valves and Hydrants
Lamp Posts, Retorts, etc.
General Foundry and Machine Work.
JOHN FOX, Selling Agent. 160 Broadway, N. Y.

THE OHIO PIPE COMPANY,

MANUFACTURERS OF

Cast Iron Gas & Water Pipe,

BRANCH AND SPECIAL CASTINGS.

Gas-House Bench Castings, Hydraulics, Lamp Posts, Flange Pipe
and Specials, Architectural Castings, Building Columns,
Joists, Cellar Grates, Sash Weights, etc.

GENERAL FOUNDERS AND MACHINISTS.

Columbus, Ohio.

M. J. DRUMMOND,



SPECIAL CASTINGS AND LAMP POSTS.
Office, Corbin Building, 192 Broadway, N. Y.

EMAUS PIPE FOUNDRY.

DONALDSON IRON COMPANY. EMAUS, PA.



MANUFACTURERS OF

CAST IRON PIPE AND SPECIAL CASTINGS
FOR WATER AND GAS.

JOS. R. THOMAS,

No. 42 Pine Street, N. Y. City.

CONSULTING AND CONSTRUCTING

Gas Engineer and Contractor.

PLANS, SPECIFICATIONS, AND ESTIMATES
FURNISHED.

Contracts taken for all Appliances
required at a Gas Works,
Either for New Works or Extensions to Old Plants.

WM. MOONEY

(Successor to WM. FARMER)

No. 94 Liberty St., N. Y. City.

GAS ENGINEER AND CONTRACTOR FOR THE ERECTION
OF GAS WORKS, OR APPARATUS OF ANY
CAPACITY.

Plans and Specifications Furnished.

WM. GARDNER,
Gas Engineer,

Lewis Block, Room 20, Pittsburgh, Pa.

Those who intend to make alterations in existing gas plants, or
who contemplate the erection of new works, will find it to their
interest to open correspondence with the above. Plans made
and estimates furnished.

GLOUCESTER IRON WORKS,
GLOUCESTER CITY, N. J.



Cast Iron Gas & Water Pipes, Stop Valves, Fire Hydrants, Gasholders. &c.

Office, Rooms 61 and 63 Bullitt Building, 131 S. 4th St., Phila., Pa.

WARREN FOUNDRY AND MACHINE CO.,

Established 1856. Works at Phillipsburgh, N. J.

New York Office, 160 Broadway.

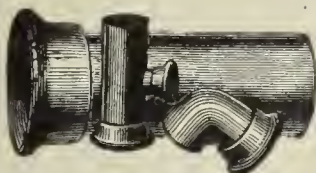

CAST IRON WATER AND GAS PIPE,

FROM TWO TO FORTY-EIGHT INCHES DIAMETER. ALSO, ALL SIZES OF

Flange Pipe for Sugar House and Mine Work. Branches, Bends, Retorts, etc., etc.

DENNIS LONG & COMPANY,

LOUISVILLE, KY.,



CAST IRON GAS & WATER PIPE & SPECIAL CASTINGS
OF ALL SIZES.

King's Treatise on Coal Gas.

A standard text-book for the Engineers and Managers of Gas Works, and for all who are concerned
or take an interest in the manufacture and distribution of Coal Gas, and in the utilization of the
Secondary Products resulting therefrom; treating also of the Gas Engine, and of Gas Cooking and
Heating Appliances

In 3 Vols. Price per Vol., \$10. Sold either by Volume or in Sets.

A. M. CALLENDER & CO., 42 Pine St., N. Y.

RETORTS AND FIRE BRICK.

J. H. GAUTIER & CO.,

CORNER OF
GREENE AND ESSEX STREETS,
JERSEY CITY, N. J.

MANUFACTURERS OF

**Clay Gas Retorts,
Gas House Tiles,
Fire Bricks, Etc. Etc.**

Ground Clay, Fire Brick and
Fire Sand in Barrels,

J. H. GAUTIER. C. E. GREGORY. C. E. GAUTIER.

BROOKLYN

Clay Retort & Fire Brick Works,
(EDWARD D. WHITE & CO.)

Manufacturers of Clay Retorts, Fire Brick,
Gas House and other Tile.

VAN DYKE, ELIZABETH, RICHARDS & PARTITION STS.
Office, 88 Van Dyke St., Brooklyn, N. Y.

RETORTS AND FIRE BRICK.

LACLEDE FIRE BRICK MFG. CO.,

MANUFACTURERS OF

Fire Brick, Gas Retorts,

AND

ST. LOUIS STANDARD SEWER PIPE.

Blast Furnace and Cupola Linings, every description of Fire
Clay Material, Fire Clay Flue Linings, Chimney Tops
Dry Milled and Crude Fire Clays, etc.

OFFICE AND DEPOT

901, 903, and 905 Pine Street,
ST. LOUIS, MO.

ESTABLISHED IN 1845.

B. KREISCHER & SONS,

OFFICE FOOT OF HOUSTON ST., E. R., N. Y.

Gas Retorts,

TILES, FIRE BRICK.

AND EVERYTHING IN THE FIRE CLAY LINE.

RETORTS AND FIRE BRICK.

MANHATTAN

FIRE BRICK & ENAMELLED CLAY

RETORT WORKS

ADAM WEBER.

**CLAY GAS RETORTS
AND RETORT SETTINGS
FIRE BRICKS, TILES, ETC.,**

Office and Works, 15th Street and Avenue C., N. Y.



Works,

LOCKPORT STATION, PA.

—ESTABLISHED 1864.—

JAMES GARDNER, JR.,

Successor to WILLIAM GARDNER & SON.

Fire Clay Goods for Gas Works.

H. A. NORTON, No. 4 CENTRAL STREET, BOSTON, MASS., Agent for the New England States.

Office, Rooms 19 & 20, Lewis Block,
PITTSBURGH, PA, P. O. Box 373.

GEO. C. HICKS,
Pres.

CHICAGO

CHAS. A. REED,
Sec. & Treas.

Retort and Fire Brick Co.,

MANUFACTURERS OF

Fire Clay Goods of all Kinds,

AND BEST QUALITY ONLY.

Regenerative Furnaces & Water Gas Goods.

45th St., Clark to La Salle, Chicago.

GEROULD'S IMPROVED RETORT CEMENT.

A Cement for patching retorts, putting on mouthpieces, and
making up all bench-work joints. This Cement is mixed ready
or use. Economic and thorough in its work. Fully warranted
o stick. For recommendations and price list address

C. L. GEROULD & CO.,

5 & 7 Skillman St., Brooklyn, N. Y.

Western Agent, H. T. GEROULD, Mendota, Ill.

**Parker-Russell
Mining and Mfg. Co.,**

CITY OFFICE,

Mermod-Jaccard Bldg., Rooms 307 & 308,
Broadway & Locust St., St. Louis. Mo.

PROPRIETORS OF THE

OAKHILL GAS RETORT & FIRE BRICK W'KS

Our immense establishment is now employed almost entirely in
the manufacture of

Materials for Gas Companies

We have studied and perfected three important points. Our re-
torts are made to stand changes of temperature, the strongest
heats of the furnace, and the abrasion of feeding and emptying.
We have the exclusive Agency for the West of the celebrated

**Kloenne-Bredel Full Depth and
Semi-Recuperator Benches,**

And also furnish and build

Our Own Styles Semi-Recuperator Furnaces
for the use of Coal or Coke as fuel.

THOS. SMITH, Prest. AUGUST LAMBLA, Vice-Prest. & Supt.

BALTIMORE

RETORT & FIRE BRICK CO.

MANUFACTORY AT

LOCUST POINT, BALTIMORE, MD.

Clay Retorts, Blocks & Tiles

**FIRE BRICK, FIRE CLAY,
AND FIRE CEMENT.**

Red and Buff Ornamental Tiles and Chim-
ney Tops. Drain and Sewer Pipe (from
2 to 30 inches). Baker Oven Tiles
12 x 12 x 2 and 10 x 10 x 2.

WALDO BROS., 88 WATER ST., BOSTON, MASS

Sole Agents the New England States.

Boston Fire Brick Works Manufacturers of **Gas Retorts and Settings**

Under the Personal Supervision of MR. GEO. C. HICKS late of Chicago.

Fire Clay Goods of all kinds. Akron Sewer Pipe, Lime, Cement, etc. Agts. for the Arc Gas Lamp & Governing Gas Burners.
Send for Circulars and Prices to

FISKE, COLEMAN & CO., Managers, No. 62 Congress Street, Boston, Mass.

HENRY MAURER & SON,
 (ESTABLISHED 1856.)
EXCELSIOR FIRE BRICK & CLAY
RETORT WORKS
 WORKS, Perth Amboy, N. J.
 OFFICE, 418 to 422 East 23d St., N. Y.
Clay Gas Retorts,
BENCH SETTINGS,
 Fire Brick, Tiles, Etc.

FLEMMING'S
Generator-Gas Furnace

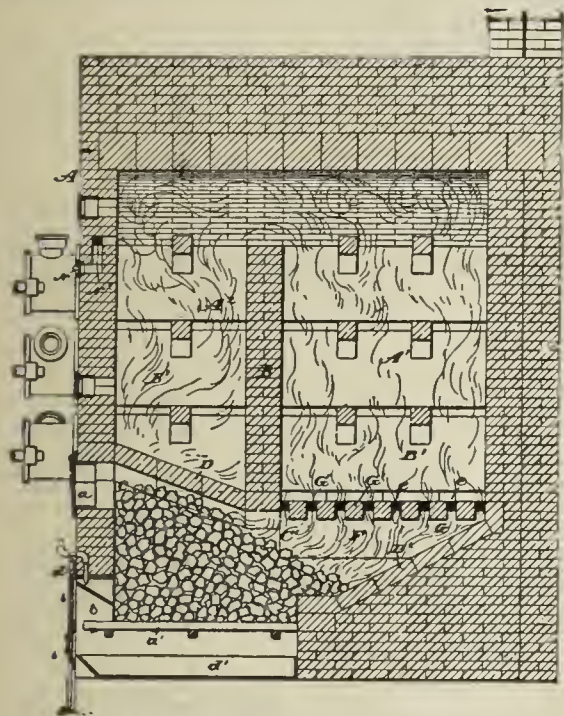

Materials furnished and Benches erected by

J. H. GAUTIER & CO., - Jersey City, N. J.

Address as above, or D. D. FLEMMING, Jersey City, N. J.

FRED. BREDEL,
 CONTRACTOR FOR THE COMPLETE
Erection and Equipment of Gas Works.
 SOLE PROPRIETOR OF THE
KLOENNE PATENTS
 FOR NORTH AMERICA.

REGENERATIVE FURNACES.
 (900 Retorts are now fired in America by the Kloenne-Bredel System.)

SELF-SEALING MOUTHPIECES.
 (Over 800 Now In Use.)

Standard Condensers. Washer-Scrubbers.

TAR WASHERS FOR WATER GAS PLANTS.
 (In use in the works of the Chicago Gas Lt. Co.)

GASHOLDERS.

Bredel's Automatic Gas Governor.

Refers, by permission, to Mr. Eugene Vanderpool, Newark, N. J.; Mr E. G. Cowdery, Milwaukee, Wis.; and Mr. Theo. Forstall, Chicago, Ills For further infomation, address

FRED. BREDEL,
No. 208 East Seventeenth Street, N. Y. City.

COMPOUND Condensing or Non-Condensing.
 16 SIZES, 5 to 500 H. P.
 Not yet equaled by any form of Engine for
HIGH FUEL DUTY AND SIMPLICITY.

STANDARD 13 Sizes in Stock.
 5 to 250 H. P.
 3000 in use in all parts of the Civilized World.

JUNIOR 6 Sizes in Stock,
 5 to 50 H. P.
 An Automatic Engine cheaper than a Slide Valve.
 WELL BUILT. ECONOMICAL. RELIABLE.
 Over 300 Sold the First Year.

All the above built strictly to Gauge with
 INTERCHANGEABLE PARTS.
 REPAIRS CARRIED IN STOCK.
 SEND FOR ILLUSTRATED CATALOGUES.

WESTINGHOUSE
ENGINES
 The Westinghouse Machine Co.
 PITTSBURGH, PA. U.S.A.

SELLING DEPARTMENT IN THE UNITED STATES.

New York, 17 Cortlandt St. } Westinghouse,
 Boston, Hathaway Building, } Church, Kerr
 Pittsburgh, Westinghouse Build'g, } & Co.
 Chicago, 156, 158 Lake St.
 Philadelphia, 608 Chestnut St. M. R. Muckle, Jr. & Co.

ST. LOUIS,
 511 NORTH FOURTH ST.,
 Westinghouse, Church, Kerr & Co.

Salt Lake City, 259 S. Main St. } Utah & Montana
 Butte, Mont. L. Granite St. } Machinery Co.
 San Francisco, 21, 23 Fremont Street, Parke & Lacy Co.
 Portland, Or. 33, 35 N. Front St. Parke & Lacy Mch. Co.
 Charlotte, N. C. 36 College St. } The D. A. Tompkins Co.
 Atlanta, Ga. 45 S. Prior St. }
 Dallas, Tex. Keating Imp. & Machine Co.
 Chattanooga, Tenn., C. E. James & Co.

Newbigging's Handbook for Gas Engineers and Managers.

The present (the fifth) edition marks an important advance on those that have gone before. Considerable additions have been made to the text, and much of it has been re-written and otherwise improved. It extends to 524 pages, and contains 193 illustrations. Price, Cloth, \$6.00.

A. M. CALLENDER & CO., - - - - No. 42 Pine Street, N. Y. City.

DAVIS & FARNUM MFG. CO.,

WALTHAM, MASS.

PRINCIPAL OFFICE AND WORKS, Waltham, Mass.

BOSTON OFFICE, Room 55, Mason Building, 70 Kilby Street.

SINGLE, DOUBLE,
AND
TRIPLE LIFT

Gas holders.

OF ANY CAPACITY.

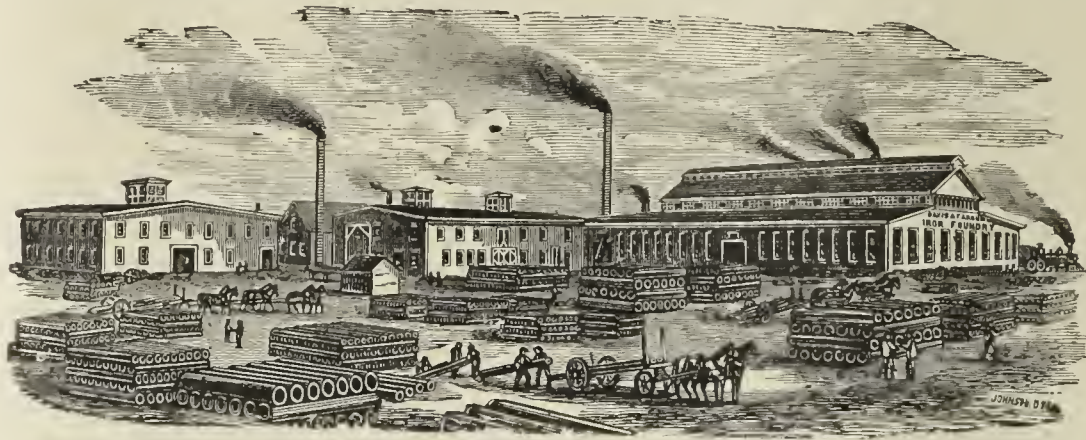

TUBULAR, PIPE,
AND
SINUOUS FRICTION

Condensers.

OF ALL SIZES.

IRON ROOF FRAMES AND FLOORS.

Purifying Boxes, Center Seal or Valve Connections, Bench Work.

Reversible Lime Trays.

SELF-SEALING AND PRESSED STEEL MOUTHPIECE LIDS.

Coke Barrows, Coal Wagons, and all Apparatus Requisite for a Complete Gas Plant.

— ALSO —

Gas and Water Pipe, Flanged Pipe,

Sugar House Work, and Special Castings of all Descriptions.

Established 1861.

Incorporated 1881.

KERR MURRAY MFG. CO.,

FORT WAYNE, IND.

Those who are in need of

Holdings or Gas Works Apparatus of any Description,

AND OF THE LATEST IMPROVEMENTS,

will find it to their interest to

GET AN ESTIMATE FROM US

before placing their order.

As we make a Specialty of this Class of Work, and are Practical Builders and Manufacturers of same,

with our long years of experience in the business,

WE CAN GUARANTEE YOU SATISFACTION.

Estimates, Plans and Specifications Furnished on Application.

BARTLETT, HAYWARD & CO.

Baltimore, Md.

Triple Double, & Single-Lift
GASHOLDERS.

Iron Holder Tanks.

ROOF FRAMES.

Cirders.

BEAMS.

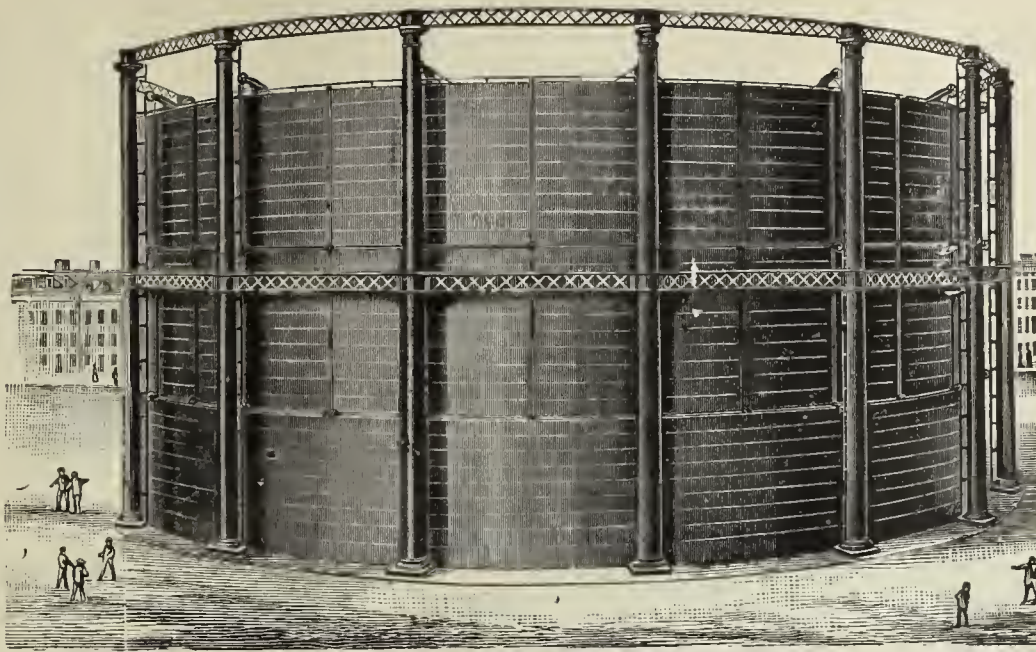

PURIFIERS.

CONDENSERS.

Scrubbers.

BENCH CASTINGS.

OIL STORAGE TANKS.

Boilers.

The Wilkinson Water Gas Process.

THIRTY-CANDLE, NON-CONDENSABLE, FIXED GAS. THE MOST SUCCESSFUL GAS PROCESS IN OPERATION.

Munich Regenerative Furnace, System Drs. Schilling & Bunte.

HAZELTON BOILERS.

Gas Works Designed and Constructed.

Pascal Iron Works. ESTABLISHED 1821. Delaware Iron Works.

MORRIS, TASKER & CO.,

INCORPORATED.

OFFICE, 224 SOUTH THIRD STREET, - - PHILADELPHIA, PA.

CONTRACTORS, BUILDERS, AND MANUFACTURERS OF

Gas, Water & Sugar Works

Bench Castings.

Condensers.

Scrubbers.

Purifiers.

Hyd. Carriages.

Iron Floors,

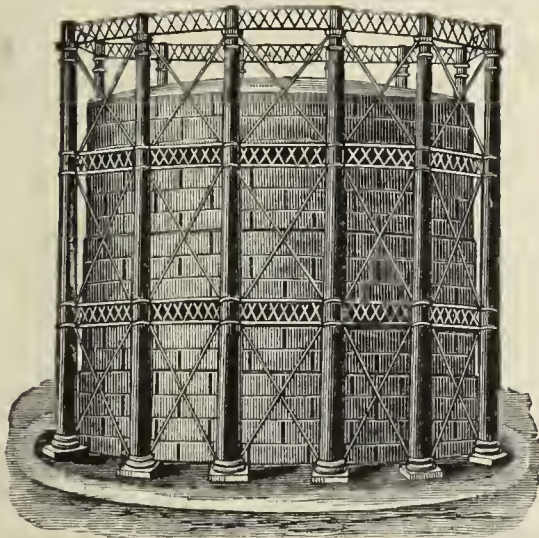

Iron Roofs.

Street Stops,

Valves, etc.

Stand-Pipes.

Water & Oil

Tanks, all Sizes.

Single, Double, and Triple-Lift Gas Holders.

SELF-SEALING RETORT LIDS. STAMPED STEEL RETORT LIDS.

Locomotive Water Columns, Filters, etc. Boiler Tubes, Wrought Iron Pipe & Fittings

Plans, Specifications and Estimates for all kinds of Machinery furnished on application.

Foundries & Works,
MILLVILLE, FLORENCE,
and CAMDEN, N. J.

R. D. WOOD & CO.,

Engineers,
Iron Founders,
and
Machinists.

400 Chestnut St., PHILADELPHIA, PA.

MANUFACTURERS OF

CAST IRON PIPE,

Gas Holders,

SINGLE, DOUBLE, AND TRIPLE LIFTS, WITH
OR WITHOUT WROUGHT IRON
OR STEEL TANKS.

PURIFIERS, CONDENSERS.

Scrubbers.

BENCH WORK.

Iron Floors and Roofs, Plate Girders.

Heavy Loam Castings.

HYDRAULIC WORK.

Lamp Posts, Valves, Etc.

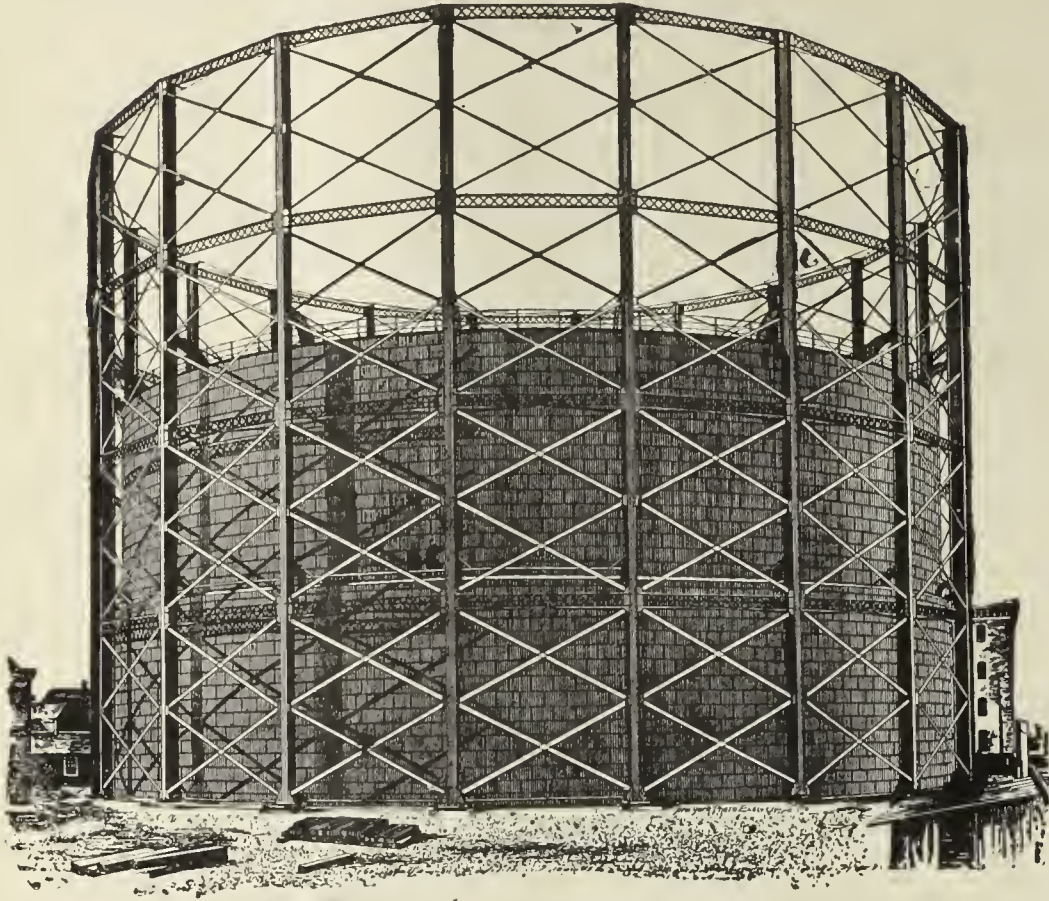

SMITH & SAYRE MFG. COMPANY,

G. G. PORTER, Pres't.

245 Broadway, N. Y.

CHAS. W. ISBELL, Sec'y.

Machinery & Apparatus for Gas Works

Drawings, Plans, and Estimates Furnished for the Improvement, Extension, or Alteration of Gas Works, or for the Construction of New Works.

Mackenzie's Patent Rotary and Steam Jet Gas Exhausters, Governors, Compensators, Condensers, Washers, Scrubbers. Isbell's Patent Automatic Street Pressure Governor, Gas and Water Valves, Hydraulic Main Dip Regulator, Bench Castings, etc. Purifying Boxes and "Standard" Scrubbers, Isbell's Patent Self-Sealing Retort Doors.

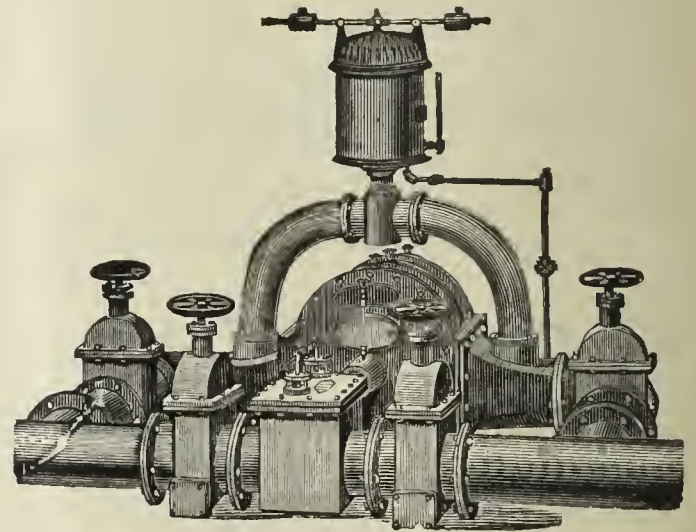

THE BRENNER SELF-SEALING RETORT DOOR.

Simple, Strong, and Durable.

CLOSES ABSOLUTELY TIGHT & IS LOCKED BY A CAM LEVER. ALL NECESSARY ADJUSTMENT FOR WEAR PROVIDED.

BUILT BY

SMITH & SAYRE MFG. CO.,

No. 245 Broadway, - - - New York City.

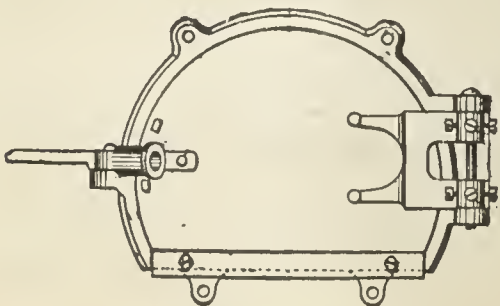

Brenner Self-Sealing Retort Door.

WILLIAM B. LUNDIE, Superintendent of the 42d Street Station of the Consolidated Gas Company, of New York, writes, under date of Jan. 4, 1889:

"We have 320 Brenner Self-Sealing Lids in use at this Station, built by the Smith & Sayre Mfg. Co. They require very little attention, and are the best of the kind that I have seen, giving entire satisfaction."

GAS WORKS APPARATUS AND CONSTRUCTION.

GAS WORKS APPARATUS AND CONSTRUCTION.

JAMES R. FLOYD & SONS,

(SUCCESSORS TO HERRING & FLOYD)

Oregon Iron Works,

W. 20th & 21st. Sts., bet. 10th & 11th Avs.,

NEW YORK CITY.

Engineers and Contractors

FOR THE

CONSTRUCTION OF GAS WORKS.

MANUFACTURERS OF

All Kinds of Castings and General Ironwork

FOR

GAS APPARATUS.

Bench Castings, Regenerative and Half Regenerative Furnace Castings.

Condensers, Scrubbers, Purifiers, Street Drips and Connections,

Valves,

Hydraulic Hoisting Purifier Carriage, Self-Sealing Retort Lids, Improved Valve Stand and Indicator,

Seller's Cement.

Plans, Specifications, and Estimates furnished for Construction of New or Alteration of Old Works.

CONTINENTAL IRON WORKS.

THOS. F. ROWLAND, Prest.

WARREN E. HILL and CHAS. H. CORBETT, V-Prests.

THOS. F. ROWLAND, JR., Sec. & Tr

P. O. Station G., BROOKLYN, N. Y.

ENGINEERS AND MANUFACTURERS OF

Gas Holders

CONDENSERS, SCRUBBERS, VALVES,

PURIFIERS, SELF-SEALING RETORT LIDS

Hydraulic Mains,

And all other articles connected with the manufacture and distribution of Gas.



H. RANSHAW, Prest. & Mangr.

WM. STACEY, Vice-Prest

T. H. BIRCH, Asst. Mangr.

R. J. TARVIN, Sec. & Treas.

STACEY MFG. CO.,

MANUFACTURERS OF

Single and Telescopic Gasholders,

IRON ROOFS, BRIDGES, LAMP POSTS,

Water and Oil Tanks, Coal Elevator Cars,

COKE CRUSHERS, BENCH CASTINGS,

And all kinds of Wrought and Cast Iron Work used in the erection of Coal and Oil Gas Works Rolling Mill Machinery and Heavy Castings a Specialty.

Foundry:

33, 35, 37 & 39 Mill Street.

Wrought Iron Works:

16, 18, 20, 22, 24 & 26 Ramsey Street:

Cincinnati, Ohio.

Bouton Foundry Co.,

FOUNDERS AND MACHINISTS,

CHICAGO, ILL.

Gas Works Apparatus,

PURIFIERS, CONDENSERS,

Bench Work

SPECIALS, LAMP POSTS,

SCRUBBERS,

Iron Roofs and Floors.

Plans and Estimates furnished for new works or extensions of old works.

1842. **DEILY & FOWLER,** 1890

Laurel Iron Works.

Address, No. 39 Laurel Street, Philadelphia, Pa.

BUILDERS OF

GASHOLDERS,

Single and Telescopic.

Holdings Built 1884 to 1888, Inclusive:

Newport, R. I.	Long Island City, N. Y.	Port Chester, N. Y.	Malden, Mass.	West Chester, Pa. (2d)
Portland, Oregon.	Macon, Ga.	New Rochelle, N. Y.	Paducah, Ky.	Lancaster, Pa. (3d)
Allegheny, Pa. (2d.)	York, Pa.	Salem, N. J. (3d)	Norwich, Conn.	Pac ny, Pa. (two)
Atlanta, Ga. (2d.)	Chester, Pa.	Omaha, Neb. (2d)	Seattle, W. T.	Mount Veruon, N. Y.
N.Y. City (Central Gas Co)	Hazleton, Pa. (2d.)	Lynn, Mass. (2d)	San Diego, Cal.	Binghamton, N. Y.
Lynchburg, Va. (2d.)	Staten Island, N. Y.	Little Rock, Ark.	Northern Gas Lt. Co., of	Concord, N. H.
Saylesville, R. I.	Saugerties, N. Y.	Irrington, N. Y.	New York, N. Y.	Dover, Del. (2d)
Rondout, N. Y.	Clinton, Mass. (Lan Mills)	South Boston, Mass.	Westerly, R. I.	Calais, Me.
Atlantic City, N. J.	Chattanooga, Tenn.	Rye, N. Y. (2)	Willimantic, Conn	New Loudon, Conn. (2d)
Augusta, Ga.	Galveston, Texas. (3d.)	Woodstock, Ont.	Montclair, N. J.	West Chester, N. Y.
Waltham, Mass. (2)	Omaha, Neb.	Malden, Mass.	Attleboro, Mass.	Bay Shore, L. I.
Mahanoy City, Pa.	Fort Plain, N. Y.	Staten Island, N. Y. (2d)	Santa Cruz, Cal.	Washington, D. C.
New Castle, Pa.	Brunswick, Ga.	Woodstock, Ont.	Erie, Pa. (2d)	

WM. HENRY WHITE,

No. 32 Pine Street, - - - New York City.

ENGINEER AND CONTRACTOR FOR THE

Erection and Extension of Gas, Water, and Electric Light Works.

SOLE REPRESENTATIVE OF THE

McILHENNY REGENERATOR FURNACE PATENTS

And the Martin Water Gas Process.

Edison Incandescent and American Arc Electric Light Plants Installed.

Correspondence with Gas Companies contemplating extending or improving their Plants respectfully invited. Plans and Estimates Furnished.

GAS COALS.

CANNEL COALS.

GAS ENRICHERS.

JAMES D. PERKINS. **PERKINS & CO.,** F. SEAVERN.
 228 & 229 Produce Exchange, New York.
 Cable Address, "PERKINS, NEW YORK." Post Office Box 3695, New York.

GENERAL SALES AGENTS FOR

The Youghiogeny River Coal Company's

OCEAN MINE YOUGHIOGHENY GAS COAL.

HON. W. L. SCOTT, Prest. M. H. TAYLOR, Vice-Prest.

This Colliery is located at SCOTT HAVEN, PA., in the center of the Youghiogeny Gas Coal District, and produces the **ONLY RELIABLE YOUGHIOGHENY COAL** for gas purposes. (See Map on p. 87 of this JOURNAL, Feb. 16, '85.)

POINTS OF SHIPMENT,

Locust Point, BALTIMORE. Pier No. 62, PHILADELPHIA.

Also, **SOLE AGENTS** for the**BRECKENRIDGE CANNEL,
OF KENTUCKY.**

Within the past two years we have delivered this Cannel to over **ONE HUNDRED COMPANIES IN THIRTY-THREE DIFFERENT STATES**, and it is now in use in some of the large Gas Works

On the Continent and in South America,

where it successfully competes with the Australian Shale. It is the **ONLY AMERICAN GAS CANNEL** of sufficiently high grade to warrant **EXPORTATION TO EUROPE AND SOUTH AMERICA**, and it is the only economical substitute for **OIL OR NAPHTHA**. **ONE GROSS TON** will produce

10,000 Cubic Feet of 75 Candle Gas,	} equal to {	750,000 Candle Feet of Gas, and 26 Bushels of merchantable Coke weighing 900 Pounds
or 12,500 " " 60 " "		
or 15,000 " " 50 " "		

This is the **ONLY GAS CANNEL** that will produce a **REALLY MERCHANTABLE COKE**. It can be delivered in parcels of one carload or more to any point in the United States or Canada. Cargo shipments of any size required can be made from **NEW YORK, PHILADELPHIA, BALTIMORE, or NEWPORT NEWS**. Samples will be sent and particulars of price, etc., forwarded upon application to above address.

**JAMES & WILLIAM WOOD,
Gas and Cannel Coal Contractors,**

No. 40 St. Enoch Sq., Glasgow. No. 2 Talbot Court, London.

Proprietors of the **BATHVILLE COLLIERIES** (which produce the celebrated **BOGHEAD CANNEL**), Shields, Shieldmuir, Drumpeller, and other Collieries. This Firm offer

STANDARD CANNELS,

Unequaled as Gas Enrichers.

Also, **WEST FAIRMONT GAS COAL, of W. Va.**

Analyses, prices, and all further information furnished on application to

Agency for U.S., Room 70 Nos. 2 & 4 Stone St., N.Y. City.

The Standard Oil Company,

REFINERS OF

NAPHTHA AND GASOLINES.

ALSO MANUFACTURERS OF

A Special Grade of Naptha for Gas Companies

FOR ENRICHING COAL GAS.

Correspondence solicited.

No. 43 Euclid Avenue, Cleveland, Ohio.

To Gas Companies.We make to order **CAP BURNERS** to burn any amount under a stated pressure. Send for samples.Also, **SERVICE CLEANERS, DRIP PUMPS, and STREET MAIN PROVING APPARATUS.****C. A. GEFROER,**

248 N 8th Street, Phila., Pa.

COKE CRUSHERS.

GAS COALS.

GAS COALS.

Newburgh Orrel Coal and Coke Co.

MINERS AND SHIPPERS OF

STEAM, SMITHING, AND GAS COALS,
Foundry and Crushed Coke.

Home Office, 33 S. Gay Street, Baltimore, Md.

J. HARRY LEE, President.

Shipping Wharves, Locust Point, Baltimore.

The Despard Gas Coal Co.,

MINERS AND SHIPPERS OF

DESPARD GAS COAL,

AND MANUFACTURERS OF

COKE.

MINES, Clarksburg, Harrison Co., W. Va.

WHARVES, Locust Point, Baltimore, Md.

OFFICE, 225 E. German St., " "

ROUSSEL & HICKS, } AGENTS. } BANGS & HORTON,
71 Broadway, N. Y. } 60 Congress St., Boston.

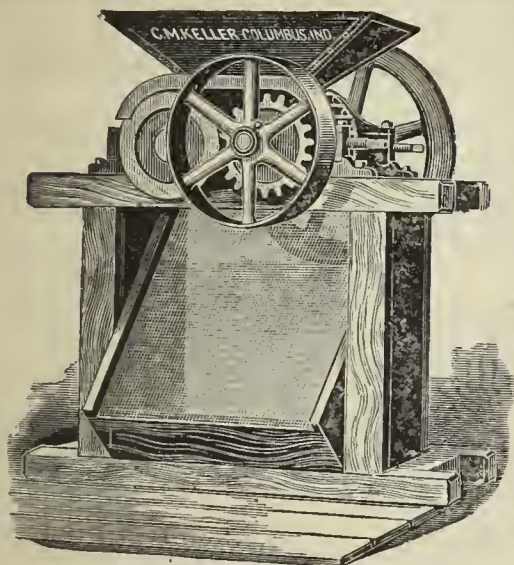

Keller's Adjustable Coke Crusher.

SIMPLE, STRONG, AND DURABLE.

C. M. Keller, Sec. & Supt. Gas Lt. & Coke Co. Columbus, Ind.

Correspondence Solicited.

King's Treatise on Coal Gas.

The most complete work on Coal Gas ever published.

Three Vols. Bound, \$30.

BOOKS.

DISTILLATION OF COAL TAR AND
AMMONIACAL LIQUOR.

By GEORGE LUNGE. Price \$12.50.

A TREATISE ON THE COMPARATIVE
COMMERCIAL VALUES OF GAS
COALS AND CANNELS.

By DAVID A. GRAHAM. 8vo., Cloth. Price \$3.

Orders for these books may be sent to this office.

A. M. CALLENDER & CO.,

42 PINE ST., N. Y. CITY

THE
PENN GAS COAL CO.

OFFER THEIR

Coal, Carefully Screened & Prepared for Gas Purposes.

Their Property is located in the Youghiogheny Coal Basin, near Irwin and Penn Stations on the Pennsylvania Railroad, and on the Youghiogheny River.

Principal Office:

209 SOUTH THIRD STREET, PHILA., PA.

Points of Shipment:

Pennsylvania Railroad Piers; Greenwich Wharves, Delaware River; Pier No. 1 (Lower Side), South Amboy, N. J.

Chesapeake & Ohio Railway Coal Agency,

FOR THE SALE OF THE

**Superior Kanawha Gas Coals, Cannelton Cannel,
Also, SPLINT AND STEAM COALS**

From the Kanawha and New River Regions, on the line of the Chesapeake & Ohio R'way.

C. B. ORCUTT, General Agent, - - No. 1 Broadway (Room 217) New York City.

FRANCIS H. JACKSON, Prest.

EDMUND H. MCCULLOUGH, V.-Prest.

CHAS. F. GODSHALL, Treas.

H. C. ADAMS, Sec.

THE WESTMORELAND COAL CO.

Chartered 1854.

Mines situated on the Pennsylvania and the Baltimore
and Ohio Railroads, in Westmoreland County, Penn.

POINTS OF SHIPMENT:

PHILADELPHIA, BALTIMORE, SOUTH AMBOY, N. J.,
WATKINS (SENECA LAKE), N. Y.

Since the commencement of operations by this Company its well-known Coal has been largely used by the Gas Companies of New England and the Middle States, and its character is established as having no superior in gas-giving qualities, and in freedom from sulphur and other impurities.

Principal Office, 224 South 3d St., Phila., Pa.

**The American Gas Engineer
and Superintendent's Handbook.**

By WILLIAM MOONEY.

Consisting of Rules, Reference Tables, and Original Matter
Pertaining to the Manufacture, Manipulation, and
Distribution of Illuminating Gas.

350 Pages, Full Gilt Morocco.

\$3.00.

A. M. CALLENDER & CO., 42 Pine St., N. Y.

JOHN J. GRIFFIN & CO.,

Nos. 1513, 1515, 1517 & 1519 Race Street, PHILADELPHIA.
52 Dey St., NEW YORK. 75 N. Clinton St., (FRED. R. PERSONS, Mangr.) CHICAGO.

MANUFACTURERS OF

METERS FOR MEASURING GAS

IN ANY VOLUME.

Provers, Gauges, Registers, Etc., Etc.

EXPERIMENTAL APPARATUS FOR QUANTITATIVE AND QUALITATIVE ANALYSIS.

Careful and Prompt Attention paid to Repairing of all kinds of Meters and Apparatus.

Estimates Cheerfully Furnished.

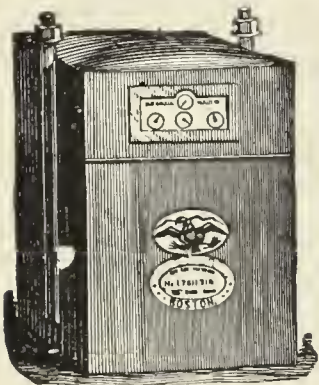

Dry Gas Meters.

With 40 years' experience and the best facilities for manufacturing, is enabled to furnish reliable work and answer orders promptly.

NATHANIEL TUFTS,

No. 153 Franklin Street, Boston, Mass.,

MANUFACTURER OF

DRY GAS METERS.

Station Meters of any Capacity.

Test and Experimental Meters, Pressure Registers, Pressure Gauges, Pressure and Vacuum Gauges.

METER PROVERS, PHOTOMETERS, STREET LANTERNS, ETC., ETC.

Patent Cluster Lanterns for Street Illumination.

HAROLD J. BELL.

BELL & JONES,

S. LEWIS JONES.

No. 12 North Ninth Street, Philadelphia, Pa. Works at Royersford, Pa.

MANUFACTURERS OF

GAS METERS, STATION AND EXPERIMENTAL METERS,
Meter Provers, Pressure Gauges, and All Other Gas Appliances in Our Line.

WE REPAIR ALL KINDS AND MAKES OF METERS, AND THE WORK GUARANTEED.

High Pressure Meters for Natural Gas, in Iron Cases, guaranteed to stand 300 lbs. Pressure.
Gas Cooking and Heating Stoves, Hot Plates, Cake Griddles, Waffle Bakers, Boiling Stoves, Laundry and Tailors' Iron Heaters. Hotel and Cafe Ranges a Specialty.

Correspondence Solicited.

Estimates Furnished.

A. HARRIS.

E. L. HARRIS.

J. A. HARRIS.

Established 1849.

HARRIS BROS. & CO.,

Twelfth and Brown Streets, Philadelphia.

Manufacturers of Wet and Dry Gas Meters,

STATION METERS, METER PROVERS,

EXPERIMENTAL METERS, SHOW OR GLAZED METERS,

Pressure and Vacuum Registers, Gauges, Photometers, Drip and Bell Pumps, Etc., Etc.

PROMPT ATTENTION GIVEN TO ALL ORDERS. METERS THOROUGHLY REPAIRED. ESTIMATES FURNISHED FOR STATION METERS OF ALL SIZES. CORRESPONDENCE SOLICITED.

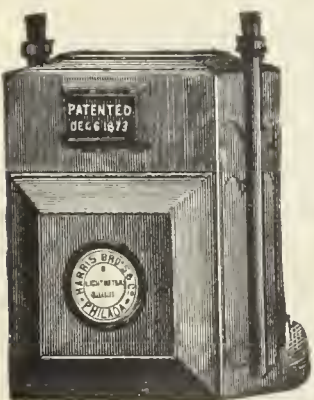

GAS METERS.

GAS METERS.

GAS METERS.

GEO. J. MCGOURKEY, Prest.

WM. H. MCFADDEN, Vice-Prest. (Phila.)

WM. N. MILSTED, Gen. Supt. and Treas. (New York).

WM. H. DOWN, Sec.

THE AMERICAN METER CO.

WET AND DRY GAS METERS.

PRESSURE REGISTERS.

METER PROVERS.

STATION METERS.

PRESSURE & VACUUM REGISTERS.

PORTABLE TEST METERS.

EXHAUSTER GOVERNORS.

PRESSURE & VACUUM GAUGES.

EXPERIMENTAL METERS.

DRY CENTER VALVES.

CRESSON GAS REGULATORS.

AMMONIA TEST METERS.

GOVERNORS FOR GAS WORKS

MARSLAND WATER METERS.

BAR & JET PHOTOMETERS.

Manufactories:

512 West 22d St., N. Y.

Arch & 22d Sts, Phila.

GAS STOVES.

SUGG'S "STANDARD" ARGAND BURNERS,

SUGG'S ILLUMINATING POWER METER,

Wet Meters, with Lizar's "Invariable Measuring" Drum.

Agencies:

177 Elm Street, Cincinnati.

244 & 246 N. Wells Street, Chicago.

510 North Second Street, St. Louis.

222 Sutter Street, San Francisco.

HELME & McILHENNY,

(Established 1848.)

CAS METER MANUFACTURERS,

Nos. 1339 to 1349 Cherry Street, Philadelphia, Pa.,

WET AND DRY GAS METERS, STATION METERS, EXPERIMENTAL METERS, METER PROVERS,

Center Seals, Pressure Registers, Governors, Indicators, Photometers, and all other kinds of Apparatus for use in Gas Works.

FOULIS' PATENT STATION AND DISTRICT GOVERNORS.

REPAIRING DEPARTMENT.—We employ a special force of skilled workmen repairing meters of all makers.

WM. WALLACE GOODWIN, President and Treasurer.

E. STEIN, Vice-President.

H. B. GOODWIN, Secretary and Superintendent.

THE GOODWIN GAS STOVE AND METER CO.,

Successors to W. W. GOODWIN & CO.

1012, 1014 and 1016 Filbert St., Phila., Pa.

142 Chambers St., New York City.

76 Dearborn, St., Chicago, Ills

WALDO BROTHERS, Agents, 88 Water Streets, Boston, Mass.

MANUFACTURERS OF

DRY AND WET GAS METERS,

Station Meters (square, cylindrical, or in staves), Glazed Meters, King's and Sugg's Experimental Meters, Lamp Post Meters, etc., etc. Meter

Provers (sizes 2, 5, and 10 feet), Pressure Gauges of all kinds, Pressure Registers, Pressure and Vacuum Registers, Pressure Indicators

(sizes 4, 6, and 9 inch), King's Pressure and Vacuum Gauges, Dry and Wet Center Seals, Dry and Wet Governors, Exhauster

Governors, Photometers of all descriptions. Letheby's Sulphur and Ammonia Test Apparatus complete. Also, Testing

and Chemical Apparatus of all kinds, and of the most perfect description, for all purposes relating to Gas.

Manufacturers of the "SUN DIAL" GAS STOVES, for Cooking and Heating.

Goodwin's Improved Lowe's Jet Photometer.

Agents for Bray's Patent Gas Burners and Lanterns.

Special attention to Repairs of Meters and all Apparatus connected with the business. All work guaranteed first-class in every particular. Orders filled promptly.

G. B. EDWARDS, Manager, New York.

S. S. STRATTON, Manager, Chicago.

D. McDONALD & CO.,

GAS METER MANUFACTURERS.

(Established 1854.)

51 Lancaster St., Albany, N. Y. 34 & 36 West Monroe St., Chicago, Ill.

STATION METERS, EXPERIMENTAL METERS, METER PROVERS, PRESSURE & VACUUM REGISTERS, PRESSURE GAUGES, ETC

Also STAR GAS STOVES, RANGES, and HEATING STOVES.

We use only the very best materials, and employ the most skilled labor, and by our long experience (32 years) and personal supervision of every detail, we feel justified in assuring the public that our goods will give perfect satisfaction. Every Meter emanating from our establishment will bear the State Inspector's BADGE, and will be fully warranted by us. Our Annual and Calendar will be sent to Gas Companies upon application.

GAS INTO POWER,

BY THE

OTTO GAS ENGINE.

GAS POWER.—A Source of Revenue to Gas Companies ready to engage in Electric Lighting, building of Water Works, Electric Street Railways, etc.

Coal for producing Gas is less in amount than that for producing Steam, both being measured on an equal amount of work performed. And, further, with Gas,

50 to 90 per Cent. of Value of Coal is Returned

by sale of Coke and Tar, according to the market value of these products.

Labor for handling fuel is reduced, by its becoming centralized and confined to the gas house, and frequently has not increased after the addition of a power station.

With Gas Power, cost of fuel is strictly limited to the time of use.

MANY VALUABLE
AND RECENT
IMPROVEMENTS.

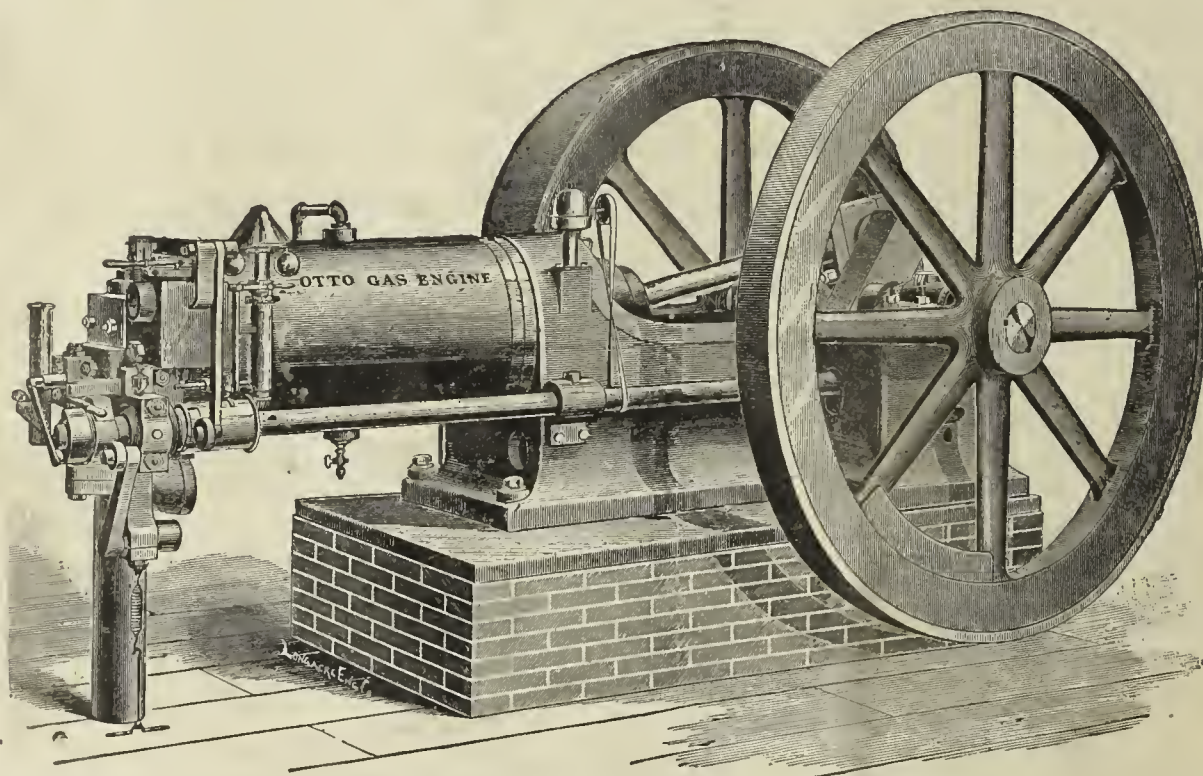

SIZES,
1-3 to 100
HORSE POWER.

Wherever Gas Companies tried Gas Power with Steam Power together in one Station, the use of Steam was subsequently abandoned or restricted, and Gas Power made to take its place.

Where Gas Companies adopt Gas Power for Electric Plants, Water Works, Sewerage, etc., they not only choose the most economical power for their use, but secure to themselves the numerous advantages of increased production, without increase of expense, and benefit thereby their entire manufacture. They induce consumers, by their example, to abandon Steam for Gas Power, and, by establishing special rates, make

**Gas Power the Leading Power of To-Day,
AND SOLVE AT ONCE THE QUESTION OF FUEL GAS.**

“Otto Gas Engine Works,”

SCHLEICHER, SCHUMM & CO.,

151 Monroe St. (Kent Building), Chicago.

33d & Walnut Sts., Phila.

NEW YORK AGENCY, 18 VESEY STREET.

THE AMERICAN

GAS LIGHT JOURNAL

REDMAN & KENNY, N.Y.

PUBLISHING OFFICE No. 42 PINE STREET

DEVOTED TO THE INTERESTS OF ILLUMINATION, VENTILATION, WATER SUPPLY AND DISTRIBUTION, & GENERAL SCIENCE.

VOLUME LII.—No. 17.
Whole No. 777.

NEW YORK, MONDAY, APRIL 28, 1890.

{ \$3 PER ANNUM,
IN ADVANCE.

A. M. CALLENDER & CO., Proprietors. C. E. SANDERSON, Manager.
JOS. R. THOMAS, C.E., Editor. T. J. CUNNINGHAM, Asst. Editor.

ENTERED AT THE POST OFFICE AT NEW YORK, N. Y.
AS SECOND CLASS MATTER.

Published on each Monday of the year, at No. 42 Pine Street, N.Y.

Terms of Subscription, Including Postage.—For the United States and Canada, \$3 per annum. European countries, \$4.50 (19 shillings—22½ francs). All payments to be made in advance. Single copies, 10 cents.

Remittances should be made either by post-office order, registered letter, or bank draft on New York, payable to the order of A. M. Callender & Co.

Collections are invariably made directly from this office, for subscriptions, advertisements, etc. We have agents to solicit the same, but they are not authorized to receipt for money.

Correspondence.—Wishing to make this JOURNAL a gazette of intelligent discussion to those of our readers who may wish to gain or give information on the subjects to which its columns are devoted, correspondence is solicited for publication from all who make the study of those subjects a pleasure or a profession.

The American News Company, Nos. 39 and 41 Chambers street, New York, are agents for this JOURNAL. Newsdealers will send orders to them.

Books.—We will forward by express, at publisher's lowest rates, any book—scientific or otherwise—to any address in the United States or Canada. No books will be sent C. O. D.

CONTENTS.

An Asterisk (*) denotes an illustrated article.

OFFICIAL NOTICE—

Western Gas Association..... 58

EDITORIALS—

Briefly Told..... 586

Another Instalment from the Western's Secretary—Public Lighting Award, New York City—Notes—Obituary Resolutions, Society of Gas Lighting: O. E. Cushing and Theo. Forstall.

The Market for Gas Securities..... 586

Some Facts Connected with the Manufacture of Water Gas, by Dr.

A. W. Wilkinson..... 587

A Method of Increasing the Consumption of Gas for Cooking and

Heating Purposes, by Mr. F. G. Dexter..... 592

*Cowell's Device for Carrying off Leakage from Gas Mains..... 593

Personal..... 593

Special English Correspondence..... 594

An Important Problem—The Gas Institute Meeting—The Profits of Electric Lighting—Oxygenated Oil Gas—Spontaneous Combustion of Coal.

ITEMS OF INTEREST FROM VARIOUS LOCALITIES..... 595

Reward for Detection of Offenders—New Gas Company—The Finish at New Bedford, Mass.—Stealing Gas—Changes in the Troy (N. Y.) Electric Light Company's Management—Electric Lighting for Belfast, Me.—The St. Paul Gas Company Entertains the Housewives—New Gas Company, Manchester, Va.—The Supreme Court Sustains the New Orleans Gas Company—Death of Jas. L. Vialle—Bridgeton's New Councilmanic Chairman—The Citizens Company, of Newark, N. J., to Make a Test Case—Annual Meeting, Flint, Mich.—Strike at the North Side Works, Chicago—Praying for a Receiver, Circleville, O.—A Discussion in the Rhode Island Senate—Hints from Helena, Mont.—The Council Bluffs Gas and Electric Light Company—And Many Other Items.

The Cheapest Light..... 597

[OFFICIAL NOTICE.]

Western Gas Association.

SECRETARY'S OFFICE, WESTERN GAS ASSOCIATION, }
QUINCY, ILLS., April 22d, 1890. }

The Thirteenth Annual Meeting of the Western Gas Association will be held at the Lindell Hotel, St. Louis, Mo., on the 21st, 22d and 23d days of May. The hall in which the business sessions of the Association will be conducted is within the hotel building, is very commodious, quiet, and in every way excellently well adapted to our requirements. The hotel management has granted on this occasion the following rates: For single room and board, \$2.75 per day; for room with bath, \$3.50 per day. These rates will apply to members in attendance, their families and visiting brethren. In this connection I am instructed by the Local Committee of Arrangements to give our members warning of the fact that in order to secure suitable accommodations, their rooms *must be engaged in advance*. Your Secretary has been in the habit of making an announcement to this effect with exceeding regularity from year to year, and just as regularly no one, or at least only very few, pays the slightest attention to the warning. The necessity of engaging quarters in advance, however, is in this instance very urgent. Now that the old Planters' House has been closed, the Southern and Lindell Hotels often have more business thrust upon them than they are capable of handling, and of late it has been no unusual occurrence for them to deny would-be guests admission, unless their rooms had been previously spoken for. But all of our members can be accommodated without the slightest jar or friction, if they will but take the trouble to address a line to the "Proprietor of the Lindell Hotel, St. Louis, Mo.," telling him the kind and price of room or rooms desired. This should be done at least one week in advance of the first day of the meeting.

In addition to the reduction in transportation rates granted by the Central Traffic Association, the Trunk Line Association has also joined in the movement. As the boundary of the latter Association extends as far east as the western border of the New England States, our Eastern friends will be enabled to avail themselves of the reduced fares.

I am authorized to state that Mr. R. D. Walsh, Chairman of the Local Committee of Arrangements, has kindly consented to take charge of all articles destined for the Gas Exhibit, and will cheerfully surrender a generous portion of his time to the interests of exhibitors. Communications, consignments of gas stoves, apparatus, burners—anything, in fact, intended for the Exhibit—may be directed to Mr. Walsh, in care of the Laclede Gas Light and Coke Company. Exhibitors can rest assured that not only will their wares receive careful handling and be displayed to the best possible advantage, but that they themselves will be accorded the most courteous treatment at the hands of Mr. Walsh and his efficient committee.

The "Paper List" for our Thirteenth Annual will be as follows:

"Relative Value of Gaseous Fuels," by B. E. Chollar.

"Effects of Natural Gas Competition," by James Somerville.

"An Argument in Favor of the Adoption of a Uniform System of Estimating the Cost of Gas in the Holder," by George G. Ramsdell.

"Impressions of British Gas Works," by George T. Thompson.

"Mixed Gases," by E. G. Cowdery.

"Wrought Iron, Cast Iron, or Steel—which is the Best Material for Street Mains?" by Eugene Printz.

"What Policy Should the Gas Interest Adopt in Connection with the Approaching World's Fair?" by Walton Clark.

"On the Abuse of the Patent System as Bearing on the Gas Industry, with a Remedy," by Frederic Egner.

The attention of the Board of Directors is called to the fact that Section I., of Article VII., of our By-Laws reads as follows: "The Board of Directors shall meet as such at least once in each year, on the day preceding the annual meeting of the Association, at which time they shall determine in regard to the propriety of the various papers, drawings, models, or other matters constituting the special order, being laid before the Association." The Board of Directors elected at our last meeting is composed of the following-named gentlemen, who are, therefore, particularly requested to assemble at the Association's headquarters on Tuesday morning, May 20, at 10 o'clock:

J. B. Howard, E. H. Jenkins, Z. T. F. Runner, John Gimper, C. W. Butterworth, E. G. Cowdery, J. S. Ambrose, J. W. Dunbar, and B. E. Chollar.

Application blanks, copies of our By-Laws, and any information not contained in these communications will be cheerfully furnished by

A. W. LITTLETON, Sec'y.

BRIEFLY TOLD.

ANOTHER INSTALMENT FROM THE WESTERN'S SECRETARY.—Secretary Littleton's current circular not only shows how rapidly everything is shaping for the coming convention of the Western Association, but also furnishes the best of proof as to what an entertaining time the members are to enjoy at their Thirteenth Annual. It certainly seems a trifle on the strange order that those who propose to visit St. Louis in mid-May should have to be urged, solely on the score of serving their own comfort, to secure their rooms in advance; but Mr. Littleton has not put this in any too forcible a way. On the contrary, he might have gone a trifle further in his advice, and yet have been within the pale of safety. We trust that his warning in respect to the closing of the "Planters' House" will be appreciated at its full meaning. It is also with pleasure that we note that the Trunk Line Association has joined the Central Traffic Association in a rate schedule, which will save many shekels to the Eastern delegation. So far, we can safely say that the proposed exhibition of gas apparatus will be a success, and Chairman Walsh is prepared to do his full duty in connection with the reception and arrangement of the goods consigned by intending exhibitors. The paper list reminds us that the Western is evidently a Gas Association, in that we fail to notice anything on the schedule which calls for an electric lighting discussion. Of course the Secretary's hint as to the time for the assembling of the Board of Directors will no doubt be all-sufficient.

PUBLIC LIGHTING AWARD, NEW YORK CITY.—The Gas Commission and the local electric lighting companies are still at wide divergence in the matter of rates to be paid and charged for the arc lighting of this city for the ensuing year, and it is not altogether improbable that the gas companies may be given opportunity during the twelvemonth of showing what can be done in the way of public illumination on a large scale by means of high candle power gas lamps and burners. There can be no doubt, however, that the electrical suppliers will not receive anything like the figures bid by them (the average rate might be put at 39½ cents per lamp per night), simply because the appropriation is not sufficiently elastic to admit of such a proceeding. So far the Commission has made but one award of any kind, and that is the allotment of about 3,600 lamps on the Equitable's lines, to be paid for at the rate of \$12 per annum each. The Mayor seems inclined to oblige the Standard Company (no bid was submitted by it) to stand by the provision of its charter, which says that "Said Company shall supply gas to the public lamps situated on the line or lines of the mains of said Company when required by the said city of New York, at a maximum rate of \$12.50 per annum for each lamp." This would not be a particular hardship were it not for the fact that it is further stipulated that that sum is to include payments on "gas lighting, extinguishing, and all maintenance and repairs." The Commission will in all probability settle the whole matter some time this week.

NOTES.—The proprietors of the Georgetown (D. C.) gas works are about to remodel their retort house, and after much investigation have decided to install 5 benches of sixes to be constructed and operated under the Flemming improved plan. Messrs. Gautier & Co. are to furnish

the fireclay materials, the iron work to be supplied by Messrs. Floyd & Sons. The same parties are under contract to erect four benches of 6's of the Flemming type at Elizabeth, N. J. The Flemming principle is meeting with deserved favor.—The plant of the Champaign and Urbana (Ills.) Gas Light and Coke Company was, on April 17th, sold at auction, for \$40,000, to satisfy a mortgage on the concern, held by Mr. Wm. Walter Phelps. The purchaser was Mr. Thomas R. White, of this city.—The Beaver Falls (Pa.) Gas Company will arrange to supply gas in the outlying districts of Barnardtown, College Hill, etc.—As previously intimated, Mr. Chas. F. Dieterich has been elected President, and Mr. Samuel Pray Secretary, of the Consolidated Indianapolis Gas Company.—The Laclede Gas Light Company has applied to Judge Valliant, of the Circuit Court, for an injunction restraining the city from carrying out the provisions of the 90-cent gas ordinance.—A gas plant is to be erected at Benton Harbor, Michigan.

OBITUARY RESOLUTIONS, SOCIETY OF GAS LIGHTING.—The following is from the records of the March meeting of the Society of Gas Lighting:

"The committee appointed to prepare a memorial of our late associate Oliver E. Cushing, respectfully submit the following: Oliver Edwards Cushing was born at Chelmsford, Mass., in March, 1829, and died in Lowell, Mass., January 17, 1890. He was one of the original members of the New England Association of Gas Engineers, and also one of the first Directors; but declined to accept the office of President. He was also one of the original members of the Guild of Gas Managers, of New England, and served as its President for two years. He was elected a non-resident member of the Society of Gas Lighting, of New York, in 1876. He was elected a member of the American Gas Light Association at its second annual meeting in 1874, and continued his membership in these several Associations up to the time of his death.

"He entered the service of the Lowell Gas Light Company, as Agent, in 1860, and continued with the Company until his death.

"Mr. Cushing's life work as a gas engineer was marked by success; and in all the various relations which he sustained to the business of gas manufacture, whether as a member of the several Associations, or as an officer of his Company, his course was always marked by a quiet dignity of manner, coupled with good practical judgment, which made him an agreeable associate and a wise and prudent counsellor. In his death we feel that this Society has lost one of its most valued and worthy members; and that his memory will always be cherished by the most kindly feelings of all his associates.

F. C. SHERMAN,
A. B. SLATER,
C. J. R. HUMPHREYS, } Committee.

"Whereas, The members of the Society of Gas Lighting being desirous of expressing their feelings upon the death of their fellow member, Theobald Forstall, at the meeting held March 27, 1890, it was

"Resolved, That in the death of our friend, the Society loses an energetic worker in the field to which we are devoted, the profession loses an able, conscientious and devoted engineer, and the gas interest one whose constant thought was centered not only on the development and advancement of the important interests which he directed, but also in the general application of theories and practices to the art of gas lighting.

"Resolved, That we extend every sympathy to his immediate family in their bereavement, and that we express by these resolutions our deep sense of the loss our Society sustains by his death.

"Resolved, That a copy of these resolutions be placed upon our minutes, and that a copy be sent to the family of deceased.

FRED. S. BENSON,
D. D. FLEMMING,
A. M. SMITH, } Committee."

The Market for Gas Securities.

The local stock market was noticeably strong yesterday and to day (Friday), and in common with the rest of the list, Consolidated moved up sharply. To-day opening transactions were made at 98½, which is an advance of 1½ points from the quotation of a week ago. We look for the par mark before many days. Equitable is in good demand at advancing figures, and Standard is also inquired after. Mutual may also furnish a good purchase, even at current rates. Chicago Trusts fluctuate somewhat, but the stock is cheap, and very cheap at anything below 50. We have no positive advices as to what was done at the meeting yesterday, but presume that the plan arranged for was put through. Consolidated, of Baltimore, is fairly strong, the upward movement evidently hingeing on the intrinsic merit of the shares. Laclede common is yet woefully weak. We repeat our advice to purchase Boston common at ruling figures.

Some Facts Connected with the Manufacture of Water Gas.

[A lecture delivered by Dr. A. W. Wilkinson, Chemist to the New York Mutual and Equitable Gas Companies, before the Society of Gas Lighting, and reported for the Society and the JOURNAL by Mr. Edmund T. Davis.]

I am a little surprised, gentlemen, that you should call upon me to address you, under the impression that I know anything about gas making, hence the best that I can do will be to give you a little of my experience in gas works. At one time I had to teach, in the City College, how to make gas; and for that purpose I had a diagram of a gas works plant, where I showed retorts, hydraulic mains, condensers, scrubbers, purifiers, etc., and I used to repeat that same old story every year. At that time I thought I knew something about making gas; but now I do not think that I know much about it. My little experience dates from the time when Messrs. Stern, Stevens & French brought to this country Tessie du Motay's new process for making oxygen and pure hydrogen gas, who proclaimed, in the city of New York, with a great flourish of trumpets, that they were going to make gas so cheap that the then existing gas companies would have either to adopt the process or go out of the business. A charter was procured in Buffalo, and the works were built—they had previously built small works in New York. Of course, we could not demonstrate that we could make oxygen very cheap in New York, for the simple reason that we made it in such small quantities, but we claimed that it would be made cheaper when we could make it in larger quantities. In Buffalo we had complete works for making oxygen, also complete works for making pure hydrogen, and it did not take long to demonstrate that we could not make oxygen cheap enough to make it a commercial article. The oxygen and hydrogen were to be used as we use oxygen and hydrogen for the calcium light; but instead of using lime we were going to use magnesia. Very soon we found that we could not make the light cheap enough, and that plan had to be abandoned.

The hydrogen was made in this way: We had a cupola for making water gas—there was nothing extraordinary about it. It was simply a vessel lined with firebrick, into which we introduced a quantity of coal, fired it, and, after it had reached a sufficiently high temperature, we passed through it steam, when the steam would be decomposed, making water gas. This was passed to the holder, and from the holder it was passed through retorts containing hydrate of lime, the object of that being to relieve the water gas of the carbonic oxide, thus making a pure hydrogen gas. This pure hydrogen gas was to be used with oxygen, as before stated. We used it hardly a dozen nights before we had to give it up—the expense was too great. Then the question arose "What can we do with the hydrogen?" It was suggested we should have a carbureter in every house, so as to render a portion of the hydrogen illuminating, and the balance of the hydrogen was to be used for heating purposes. You practical men will see the difficulty that would arise by attempting to cart around naphtha and placing a quantity in every house. Of course, that plan had to be abandoned almost as soon as it was tested. At that time I was called upon to advise what could be done with the works they then had on hand. It was suggested that the gas should be carbureted at the works. M. Tessie thought that if we carbureted the hydrogen there at a low temperature it would carry the naphtha without condensation; but if we made any quantity you will see the difficulty attending that plan. I suggested that the hydrogen should be passed through the carbureter, and then through a red-hot retort, thus making a fixed gas. From that point we succeeded in making a gas which was very satisfactory; but we found that the hydrogen was altogether too expensive; in fact it cost more to pass the hydrogen through the hydrate of lime in the retort than ordinary coal gas cost in the holder. Consequently we had to abandon that plan. We finally passed the water gas direct from the cupola to the holder, then through the carbureter, and then through the retort, and made gas in that way. But we found that it was difficult to get men to properly manage the works, whereupon the whole thing fell through.

That was my first experience in the making of what was known as water gas. Baron Jerzmanowski afterwards built works in Troy; but two or three years passed by before we made another attempt in New York to construct works for making illuminating water gas. Mr. Stern was a very active and persevering man, and forced every undertaking to success. He came to me one day and asked if I would meet some gentlemen who proposed putting money into water gas works. I told him I would give them all the information that I could. The first question asked was, "How cheap can you make gas?" I replied that we could make a high candle power gas at 50 cents per 1,000 feet; men who were posted thought that \$1 per 1,000 feet would be very satisfactory. He succeeded in getting the money and built the works. From that grew

up the process that is used at the Municipal, the Mutual and other works—the process being, first, by making water gas in a cupola, then passing it through a carbureter to give it a sufficient quantity of the vapor of naphtha for the candle power required, then passing it through the retort so as to break up the naphtha into a gaseous form, and then purifying it, after which it is ready for the holder. The process of Tessie du Motay which we started in with, proved a failure, but from it we developed the process which is now used by several companies.

About (or before) this time, Mr. Lowe had suggested a process for making water gas. He filled a cupola with coal, and fired it (passing the products of combustion down through loose brickwork) in a vessel called a superheater, and when the brick were very hot shut off the air and turned on steam, and on the top of the coal threw naphtha, which in going down through the hot brickwork would become more or less a fixed gas. You see the difficulty of making gas in that way. In our way of making gas you have a better control over the products which you obtain. Of course, you are all familiar with the Lowe process. You know that you start with more heat than you require, then you will have it just about right; but finally you have less heat than you require to decompose the naphtha. What we look for in our way of making gas is to make all the gas we can from the coal in the cupola. That is the first step. That, of course, is water gas. The next thing is to give that gas a sufficient amount of the vapor of naphtha to make the candle power we wish. The next thing is to fix that naphtha, or make gas of it.

If you will compare the two you will see that we have two distinct processes for making what is known to-day as water gas. Several modifications of Lowe's apparatus have been made, but in every case the principle has remained the same, and has been so decided by the highest courts, and his patents sustained.

We have made improvements in the different parts of the apparatus originally designed by us, but the principle upon which the gas was first made remains the same. I will now proceed to give in detail the process.

If we pass steam through red-hot carbon we will produce, in the first place, carbonic acid, CO_2 ; then, as the carbonic acid passes through the red-hot coal, we shall make carbonic oxide, or CO ; the hydrogen of the water, or from the decomposed steam, will be set free, and at the same time a little light carbureted hydrogen is formed, or compounds of carbon and hydrogen— CH_4 by the old formula. There is in the coal a little sulphur, which will go off as sulphureted hydrogen. There is no ammonia.

To repeat, as we decompose the steam by red-hot coal we will get carbonic acid, carbonic oxide, hydrogen, light carbureted and sulphureted hydrogen. All of these gases, with one exception, are combustible gases. If we examine illuminating gas we will find, first, a combustible gas; second, a gas capable of giving illumination. Either of these gases above named will answer the purpose, excepting carbonic acid. Of course hydrogen would be the best, everything considered; but pure hydrogen is too expensive to be thought of. Practically we have to take these three—carbonic oxide, hydrogen, and light carbureted hydrogen—as our carrying or combustible gas. Of these we need from 85 to 95 per cent. of all the gas we make for illuminating purposes. The gas that gives illumination is a compound of hydrogen and carbon, and when derived from naphtha it is in the proportion of 3 of carbon to 5 of hydrogen. We need this mixture for perfect combustion. You might ask, Why not leave out this 85 per cent. and make pure oil gas? You cannot get a burner that will burn that gas perfectly.

The important question is, "Where can you get these combustible gases cheapest?" You get them when you decompose soft coal; you get them when you decompose wood; or you can get them by passing steam through red-hot carbon. Thus the engineer has a choice. There may be places where it is cheaper to distil coal to get those gases; but there are other places where wood would serve a better purpose, and be cheaper; and there are still other places where hard coal would be a preferable substance to use.

The carbonic oxide has been the gas which has caused the most trouble in water gas. Carbonic oxide is a poison—a very virulent poison. We used to experiment with carbonic acid and with carbonic oxide by taking a pigeon and putting it in a jar of carbonic acid; it would die, but not very quickly—if we kept it for only a certain length of time and then let it out it would recover; but if we put the pigeon in a jar of carbonic oxide it would die very quickly—if there for a short time it would not recover. That has been the trouble with water gas—the carbonic oxide was so poisonous. But we do not make this to breathe; we make it to burn. And any engineer who would carry on his works so carelessly as to allow that gas to escape in quantities that would be dangerous to

life does not attend to his business. We make this gas to sell, to be burned; and when it is burned it is perfectly safe.

Now, how much gas can we make from coal? for that decides the whole thing. You will probably be surprised when I tell you that we can make from coal in the cupola (leaving out the steam) more pounds of these three gases than we have pounds of coal in the cupola. I have done it. That is, I have made more pounds of gas than I have had pounds of coal in the cupola. If I put 100 pounds of coal in the cupola and under the boiler, I can get out of it 75 per cent., or 75 pounds in the shape of gas. If we take the absolute amount of carbons in these two gases, we find we can actually send out one-half of the weight of the carbons that we use, in the shape of gas. I mention these facts for the reason that it has been suggested that we use gas for heating purposes. In doing that we shall have a leeway of one-half of the carbons. In other words, we can give you one-half of the carbons in the shape of a gas which will be ready for use. We have to use a certain amount of coal to produce the gas. You have to burn up a certain amount. Consequently we are pretty near the end of the route as regards the amount of gas that can be made. This is a suggestion to be considered in connection with the question of what we can do with water gas as a heating agent. Can we afford to use it in that way? Can we afford to sacrifice one-half of the carbon for the sake of the other half? And what prices can we charge? If a man can get a ton of coal for \$5, we must charge him more than double the amount for the ton of coal in the shape of gas.

These are facts that are now coming before the people. In the Western States where they do not have natural gas this is a question that they are thinking of very seriously: "Can we make this artificial gas cheap enough for them to use it for fuel purposes, instead of coal?" You can judge for yourselves whether or not you can do it here.

At the Mutual works we make water gas, purify it and measure it—that gives us an opportunity of knowing how many feet of gas we are making from a ton of coal; and I have seen made there as high as 65,000 feet per ton of coal in the cupola. If you figure up the weight of the gas you will find that it is very nearly the weight of the coal that you use. Where do we get the extra weight? We get it from the oxygen which comes from the steam. If we take the coal burned under the boilers and in the cupola, we can make 45,000 feet from a ton of coal. If we reckon the weight of 45,000 feet of gas we will find that it makes a good many pounds. It is working very close. It is working so close that we have but very little leeway out of a possible 100. Shall we manufacture this gas for heating purposes? I think it is coming to that. They say now that in the West you cannot hire a servant girl in a house where they do not use gas for cooking; they will not use coal; they have got to have gas, or they will not go into the house. The great convenience of it will undoubtedly force us ultimately to the making of water gas for domestic purposes, for heating our houses and for doing our cooking. The question will arise right away, how does this gas compare with natural gas for heating purposes? Take the composition of water gas as 5 per cent. of carbonic acid, 40 per cent. of carbonic oxide, something like 50 per cent. of hydrogen, and only about 5 per cent. of light carbureted hydrogen, and see how much oxygen they require. We find that there is only about two-thirds (hardly that) of the heating qualities in this water gas that there is in natural gas or in coal gas. Consequently we cannot say that pure water gas will do the same amount of heating that natural gas will. Some assume that a foot of gas ought to be the same in both cases. But it is not the same. All of you are familiar with the fact that you can drive an engine better with coal gas than you can with water gas, for the simple reason that it calls for more oxygen than this water gas does. But, if for any cause we are able to make that gas very cheap, it is possible it will become the future gas for heating purposes.

Now, leaving the heat out of the question, let us look and see what we can do with it for light. I have already told you that we can have in the cupola as high as 65,000 feet of gas from a ton of coal—taking the cupola and the boiler together we can average almost 45,000. Upon looking over the books I find that the average for the year was about that, so that it is not impossible to do it. I think we can take as the average 45,000 feet to the ton. That then gives you a basis upon which to figure your illuminating gas, and what you will use to give illumination. You can do this by using very rich cannel coal. If you pass this gas through a retort distilling cannel coal you will get a very pretty gas; but in this country, where we have petroleum in abundance, we can use that instead of cannel coal—if we use crude oil it will work just as well. I do not know but what we can make more with crude oil than we can with naphtha; it is heavier, has greater gravity. The naphtha boils at a very low temperature, and the crude oil boils at a much higher tem-

perature, consequently you require more heat to decompose the crude oil than you do the light naphtha. At one time engineers had the idea that naphtha did not add to the volume of gas. At the Mutual works we have a means of measuring the water gas, and we also measure it again after the naphtha gas has been added, and find that the increase is from 33 to 40 per cent. In other words, that instead of taking 1,000 feet of water gas we only required 650 feet of water gas, and the balance of the 1,000 is made up from naphtha. At the Mutual works we have averaged over 80 feet for every gallon of oil that we used in the works. Now, with 80 feet from every gallon you can easily figure the cost of your gas. We find that we can make a 30-candle gas with 4½ gallons of naphtha; we are doing it right along—it seldom ever reaches as high as 5 gallons. In the winter time we require more than we do in the summer. The average is 4½ gallons right straight through for the year. At first we thought we had to have retorts filled with all sorts of brickwork, so as to make the gas tumble about in all sorts of directions to break the naphtha into gas. Now, we know that if we have the retort perfectly polished and heated to the right kind of heat we can decompose it better.

We measure very carefully every bit of waste oil that we have at the works, and there is not one quarter of one per cent. of the oil that we use that comes back to us in the shape of waste products. We can use that under our beuches, or we can burn it in our lime kiln.

So much, then, for the decomposition of the naphtha. You might ask: "Why not pass the oil through the retort by itself?" If you do, you deposit lamp-black and make a heavy oil, and you will not get anything like the full value of the naphtha in that way. You possibly might make 40 or 55 feet of gas per gallon; but in the presence of hydrogen or of water gas you can decompose it so that you have almost a perfect decomposition. Those are the points that we are working for—to convert all of the oil into gas without any waste whatever; and it only requires a little care and attention to enable us to do it.

Now, as to the candle power. We find it is as easy to make 30 or 35 candle power as it is to make 16 candle power; and in fact, if we should get down to 16 or 20 candles it would look so poor that we would be ashamed of it. We have to make high candle power; and when you make that high candle power you do not necessarily have smoke. You can make it brilliant and white, as you all know; and there is no tendency to smoke when made in this way. The gas burns perfectly free; and we could easily carry the candle power up to 35 without smoke, if we take proper care in decomposing the oil.

As to purification. When we look over these gases we find that the carbonic acid is about the only one to be taken out. That will hurt the candle power, but not so much as it hurts the candle power of coal gas. At the Equitable works they carry as high as six per cent. of carbonic acid in their gas, and it costs them only half a gallon more of oil to make up the candle power. In other words, if we use lime to take that out we can use one-half gallon less of oil. Consequently, it is cheaper to let that gas go than it is to undertake to take it out.

Prof. Horsford at one time, in looking over an analysis of water gas, said that if there was nothing else to recommend this gas the purity should recommend it to every company. In water gas we should not get more than 3 to 5 grains of sulphur per 100 feet; and it seldom reaches as high as that—it must be very poor coal that will give us as much as 3 or 5 grains per 100 feet—and no ammonia. Consequently, when we burn the gas in a room, we have less impurities than any other gas. Compare this with coal gas, where we have from 20 to 40 grains of sulphur and from 5 to 7 grains of ammonia to the 100 feet.

When sulphur burns it burns into sulphurous and sulphuric acid and when ammonia burns it burns into nitrous and nitric acid; 40 grains of sulphur will make 88 grains of sulphuric acid and 5 grains of ammonia will make 18 grains of nitric acid. These acids are very unhealthy to breathe, and we need not wonder that our wives and children, who are confined in close, well-lighted rooms, look pale, have headaches, sore throats, and, finally, consumption. We send them to the country where they do not get the gas and they get better; we bring them home, light more gas to make it more cheerful, and poison them by slow poison, and, finally, when we carry them to their last home, we thank God we tried to make it cheerful, we burned all the gas we could, we have sacrificed those most near and dear to us to save some drunken "bum" who might, in his stupor, blow out the gas and die an hour sooner than he would with coal gas.

In a dry goods store, where the goods are piled on shelves, if you burn coal gas containing these impurities, you will find after a time that the burning of the gas will bleach the edges of the goods—this is done by the acid that is produced by burning sulphur and ammonia—but with the use of water gas we do not have it to anything like the same extent. They tell us they prefer to have water gas because it

does not bleach or fade their goods. Therefore, water gas has these qualities to recommend it.

A few words as regards the construction of the cupola to make this gas to the best advantage. Of course, we have to make a cupola from which we shall get the greatest amount of gas out of our material per man. I have made cupolas 5 feet in diameter, 6 feet in diameter, and 8 feet in diameter. The small cupolas will make slightly more gas per pound than the larger ones, but it takes just as much labor to handle the small cupola as it does the larger one, and, consequently, we have to make them just as large as we can in order to get satisfactory results. I have never made one larger than 8 feet in diameter. As to the depth of carbon in the cupola, if we only have a short column of coal for the steam to pass through we shall get more carbonic acid; the greater depth of coal we have in the cupola the more carbonic acid will be converted into carbonic oxide. That is what we work for. We want to get just as much carbonic oxide in the gas as we can. We want to get all the carbonic acid converted into carbonic oxide.

Lately we have been passing the steam through 8 feet of red-hot carbon, and for the last few weeks we have been running the carbonic acid down to 3 per cent. in the water gas; and in the commercial gas it would be about 2 per cent. You can let that amount go. Consequently we do not need the lime purification; but with gas made in this way there are always some traces of oil still sticking to the gas. We get some vapor of naphtha. We have to pass that through some sort of purifier. If iron oxide is cheap we pass it through it. If there is sulphureted hydrogen in it, the iron will take care of that. At the same time it will act as a filter—you will find that the iron will become moistened with whatever stray oil there is; and it is desirable to filter that out. There is not much of it. You can run a box for a month and still not have it very wet; but we cannot let that oil go through. If we do we will find a quantity of oil condensed in the mains. I do not care anything about purification—leave all the purification out, except the purification which we get by filtering it (we can filter the gas until we clean it completely of the stray oil), and then we have got an elegant gas. What it may lack in candle power from the presence of carbonic acid we can make up by using a little more oil.

As regards the effect of cold upon this gas. I have passed the gas through 60 feet of inch lead pipe covered with ice and salt, and have lost but a candle or two by doing so. We all know how well it will stand exposure to cold, the reason being that the gases that we make—those heavy hydrocarbon gases of the C_2H_2 type—at this very low temperature do not crystallize.

At the Mutual works I have never seen an ounce of naphthaline made. At the Baltimore works the men said that they did not know anything about naphthaline, and never had seen it. We do not make it for the simple reason that we do not carry the heat high enough to make those solid bodies. We carry heat just sufficient to make a gas, which, if reduced by cold, will still be a liquid.

With regard to the cost. You are all perfectly familiar with the handling of coal gas, and know just what you can do. In the making of gas in this way we, so to speak, make it by machinery—just as a great many articles are made by machinery—and thus save hand labor; and so this gas is made by machinery. The labor is very much less than that of handling ordinary coal gas. When we first started we drew the charges out of the cupolas once every day. We cleaned out generally once in 12 hours. Now we do not clean out the cupola once a week. We open the ashpit door, take out the ashes, rattle the coal down, and go on again; and we run for a week or 10 days without change. We find that that is a great saving. The men who wheel in the coal and dump it in the cupola do not have very hard work, nor is it skilled work. The men who handle the valves do not have very heavy work. You are all familiar with the fact that you can make some 15,000 or 25,000 feet of coal gas per man; but with this way of making gas our books show that every man engaged in the gas making—taking them all into consideration—can make from 100,000 to 110,000 feet. When we first started we thought that one man had all that he could attend to in attending to two cupolas. This year one man attends to four cupolas. All he has to do is to change the valves every 10 minutes. We find that he might just as well occupy his time in attending to four cupolas as in attending to two cupolas; and consequently we have made more gas per man by giving him more cupolas to attend.

Then, again, we find we have made more gas per retort for the amount of coal burned, because the setting has been better. At first we had a very heavy setting—such as would support 200 or 300 pounds of coal. Now we put in just a skeleton setting.

You may ask what our benches will do. We find we can run,

through a bench of six retorts, 400,000 to 450,000 feet of gas in a day. I was in Washington recently and found that there they were running 600,000 feet per bench per day, and were doing it just as easily as we were running 400,000 or 450,000. I believe that with a properly constructed regenerator furnace we might run 700,000 or 800,000 feet to the bench.

As regards fuel. When I first went to the Mutual works I was told it was impossible to heat the benches properly without coke, and that interfered with this way of making gas, because we always had to have coke for the benches. We tried all sorts of arrangements to burn hard coal, and they were more or less successful. Finally we came down to so simple a thing as just lengthening the stack. We put about 30 feet of pipe on the stack, and then we were able to burn hard coal better than we had burned coke, and the men would rather attend the fires with hard coal than they would with coke. So that we are out of the woods in that respect. We do not have to have coke, and we can use hard coal. In fact, we use nothing but hard coal all through the works—under our benches, in the cupolas, and in the boilers. We can use a very cheap variety of coal. We never use better than pea coal, we use up all our screenings, and have no waste.

There are a few things which I have learned practically in handling works of this kind. In the first place we want a boiler that will give high pressure steam, and as hot as you can make it. We want that boiler to be as close to the cupola as we can get it. A good many times the water gas process has been a failure because the steam had to be carried so far that when it got to the cupola it was not in a shape to do its work. Place the boilers as close to the cupolas as you can get them, so that the steam only has to travel 7 or 8 feet to get to the first cupola. We find that the first cupola will make more gas in proportion than the others that are further away.

Not only do we want hot steam, but we find that if we can dry that steam we are still better off. When M. Tessie first came out here with his cupola we then used about 40 pounds of steam. He thought that it was absolutely necessary to use superheated steam. Anybody who has had experience with superheated steam knows the difficulties in the way of its use. We do not superheat our steam now. We get hot steam at 100 pounds pressure, and get it into the cupola as soon as possible from the boiler. In that way we have had a great deal of success. Anyone who will undertake to run a boiler which is 200 or 300 feet from the cupola will have very poor success. You want to put them as close together as possible and get your steam as hot as you can.

We have made certain improvements in the making of water gas. One improvement is by introducing the steam a part of the time at the top of the cupola—in blowing up the cupola the top of the cupola soon becomes very hot; pretty soon the whole top of the cupola was red-hot, and, of course, the valves and covers would warp. I suggested the idea of putting the steam in at the top for half of the run instead of introducing all the steam at the bottom and driving the heat all to the top. I found that I could make about 5,000 feet more of gas per ton of coal by doing so, and at the same time did not burn out my cupolas. In fact the repairs of the cupolas are very slight indeed. We find that per 1,000 feet of gas the repairs to the cupolas are hardly worth mentioning.

Of course, you may get hold of coal which will clinker; but even with such coal, if you pass the steam both ways, a part of the time below and a part of the time above, it will break up the clinkering so that it will give but very little trouble.

Then, again, as regards the grate bars. We never burn them out. We have the same bars in now that were there at first. They are $1\frac{1}{2}$ -inch square iron bars.

When we first made the gas there was any quantity of trouble with the valves. We found that this red-hot gas coming in contact with the valves soon burned them out; but it did not take much thought to put these valves all under water, and we have had no trouble with them since. The gas is taken out red-hot, but it has to strike the water before it can touch the valve; consequently we have no more trouble with the valves.

In making this gas we do not require skilled workmen. The best men we have came there as common laborers. It does not seem to require any extraordinary knowledge to enable them to handle the valves. In making gas through the retort, a man learns to make it in a very short time, and without any trouble. Of course, if he is careless he can soon fill the standpipe full of carbon and the hydraulic main full of pitch; a little attention will save all this.

We can make high candle power, any candle power we want, just simply by opening or shutting the valve that lets in the naphtha; you can easily control that.

For vaporizing naphtha, we need a carbureter large enough, and well

supplied with steam, to vaporize the naphtha, so that when mixed with the gas it will decompose easily.

I have been making some experiments with crude oil and with the Lima oil, and I find that I can make gas just as well with that. Of course it requires more heat in the bench to do it, but it can be done; and if naphtha should go out of our reach to-day, and the crude oil remain, it would not interfere with us a single day. We should make gas just the same, and just as good.

As I have already said, it seems ridiculous for me to undertake to talk to you about gas making; I have told you about all that I know about the art. I know there are men here who have had years of experience, and are, therefore, better posted in every way than I am, and who can give us all the details. If there are any questions which you would like to ask, suggested by anything I have said, I shall be happy to answer you. Mr. Bradley can tell you many things that I have not thought of, and he ought to be made to talk.

Discussion.

Mr. Bradley—I think that you have covered the ground pretty well.

Mr. Benson—It might be of interest, now, if we could get Mr. Bradley to cross-examine the witness on the points suggested.

Mr. Bradley—I do not think I can add anything to what Dr. Wilkinson has said.

Mr. Benson—Of course it is understood beforehand that there shall be no questions asked the Doctor which would tend to criminate the witness.

Dr. Wilkinson—I have been in the position oftentimes in the college of not only having to ask questions, but also to answer them; and oftentimes some of these boys would ask very difficult questions, that I have had to get out of in some way.

Mr. Benson—You remarked that if naphtha should go out of your reach, and crude oil remain, you would still be able to make gas about as cheaply, and with as little difficulty. I would like to ask you if the residuals of crude oil would not be more difficult to take care of; and whether or not the present regulations of the Board of Health would not tend to embarrass you somewhat in the manipulation of the residuals.

Dr. Wilkinson—We have always worked on the principle of never allowing any waste; and if we should use crude oil to-day we would not make any more waste than we do now. With crude oil, as pumped out of the earth, of course there comes a lot of dust that will remain in the retort, and that will accumulate after you have made a good many thousand feet. We would have that to contend with. The oil that we now have is pretty clean, and consequently we have nothing in the way of sediment to dispose of, as we would have if we were using all crude oil. Otherwise than that, we would have no great waste, and there would be no more heavy oil, tar, or pitch than from gas made from naphtha. There is no necessity of making a particle of waste oil. If they only attend to the benches properly they need not make any heavy oil at all. We might filter a little out in the purifying boxes, and it is possible we might get a little from the street; but it would be so exceedingly small as to be of no account. We made a careful estimate a few winters ago of the actual amount of heavy oil that we made, and that coming in from the street—I had every particle of it collected—and I found that while we were using 15,000 gallons of oil per day we did not get 200 gallons of oil back. So that it is possible to work up almost every particle of it, with the exception that I have mentioned—that if you use heavy oil a little sediment will accumulate.

Mr. Thomas—I do not suppose there would be any particular objection to using the ordinary crude oil, but Lima oil might be objectionable.

Dr. Wilkinson—I will tell you what we have found. Within the last year or so we have been using naphtha that was not as good as the naphtha that we used to get; and the stuff made a smell in the gas that we could not take out with either iron or lime. We found that lime would work better than iron, but still an odor remained which was very much like the odor of a skunk. Now, as long as that gas burns it is all right. The odor is that of sulpho-hydrocarbon; the amount of the sulphur is exceedingly small. You might take a bushel of onions and you would not get a grain of sulphur out of them; and yet you know that a bushel of onions is capable of making a great deal of a stink. And so it is with this oil. The amount of sulphur in it is exceedingly small, but what there is there is in the shape of a very rich smelling body. When a servant girl lights the gas her usual way of proceeding is to turn the gas on and then hunt around for a match, and when she finds it she will light the gas; and in the meantime the gas has been escaping in the room. A gas with such a pungent odor in it does not take very

much of it in the room to be noticeable. That odor is probably owing to the naphtha made from the Lima oil. It is probable that we get in the light naphthas some of those very strong smelling bodies; but if we burn it all, it is all burned up, and the odor is not noticeable. It is only when the gas is allowed to escape that it gives trouble.

Mr. Thomas—As between the ordinary crude oil and the Lima oil, what would be the difference in the amount of lime that it would be necessary to use in purification, in order to eliminate all of the odor?

Dr. Wilkinson—It is not all in a shape that will combine with lime chemically. With ordinary sulphureted hydrogen, when we pass it through the hydrate of lime we form the sulphide of calcium; but this sulpho-hydrocarbon does not combine with lime, neither does it combine with the oxide of iron, and we cannot filter it out in that way because we cannot combine it. We purify as thoroughly as we can the water gas, so that we get rid of every trace of sulphureted hydrogen. After the naphtha gas is added it passes through lime. Mr. Kennedy gave orders to fill those boxes with lime instead of iron. We do not change the boxes because the gas gives a test of sulphureted hydrogen, but we changed because the oil began to accumulate there and make a back pressure. It did not seem to have the power of combining with this gas. It is not a pure, simple gas; if it were we could get rid of it easily. It is a compound gas, that will not combine with any ordinary substance which we use in purification.

Mr. Flemming—What is the temperature of the gas as it comes from the retorts?

Mr. Wilkinson—It is only a little above red heat. It hardly reaches a red heat until it has passed two thirds the length of the retort. As it goes off in the stand-pipe it is not hot enough to make a cherry red heat.

Mr. Flemming—Do you think that the whole body of gas as it passes the retort is acted upon and changed at all?

Mr. Wilkinson—Yes; I judge by the fact that if it was not we should have the oil condensed out.

Mr. Flemming—Why do you prefer naphtha to crude oil?

Mr. Wilkinson—Simply because one boils at less than 212° and the other at 600°.

Mr. Flemming—The cost of one is nearly double that of the other, is it not?

Mr. Wilkinson—Yes; but with one we should have to use more coal under the retort. In other words, instead of making between 400,000 and 500,000 feet to the bench we would not be able to make more than 300,000. We would have to use more coke. We cannot have the cake and the penny too. If we get light naphthas they will decompose easily; if we get a heavy oil we have to use more coal. So that although you can use this Lima oil at 2 cents as against 4½ cents for naphtha, still it is not all profit. You have got to burn more coal and you lose money there. The chances also are that your stand-pipes will stop; you will fill the hydraulic main, and you will give the man more work outside of the benches than you would in using naphtha. I have figured that up, and although the figures are in favor of using the heavy oil, they are only slightly in favor of it; yet I should prefer naphtha for the sake of keeping a less number of men busy about the works. One advantage that we claim for the process is that you can make a pure gas cheaply, and at the same time get rid of a good many men at the works. When you can make 100,000 feet to a man instead of 20,000, you get more work for your money; and the fewer men you have about the works the better off and the happier you are.

Mr. Nettleton—I understood you to say that practically there was no need of purifying this gas, and yet, as far as my information goes (I know nothing about it practically), it costs fully as much to purify water gas as it does to purify coal gas. Within the year I have heard the statement made that it costs *more* to purify water gas than it does to purify coal gas. Is there anything about your process which makes the gas freer from sulphur or sulphureted hydrogen than is the gas made by the ordinary process?

Mr. Wilkinson—If we take ordinary hard coal the amount of sulphur that there is in it is about one-half the amount we get in ordinary soft coal. Now, with ordinary soft coal, if you get 10,000 or 12,000 feet you will get about all the sulphur that there is in the coal in the 10,000 or 12,000 feet; but as we put the coal in the cupola and make 60,000 feet we divide the sulphur into so much smaller quantities per thousand feet that the amount of sulphur becomes unimportant. I have a very perfect apparatus for testing the quantity of sulphureted hydrogen contained in the gas, and I cannot get a sufficient rise in the tube to show one-tenth or one-twelfth of one per cent. of sulphureted hydrogen, and that quantity is so very small that it is not worth noticing. Then, again, as regards the carbonic acid. Where you make a very high candle power gas the carbonic acid does not have the deleterious

effect that it does with a gas of lower candle power. We reckon that one per cent. of carbonic acid in 16-candle gas would take off about one candle. At the Equitable works they run six per cent. of carbonic acid, and I know that it does not take off one-sixth or anything like it. The deleterious effect of carbonic acid on high candle power gas is not so marked as it is on low candle power gas. Then, again, you do not need to have carbonic acid as high as 5 per cent. You can run with much less than 5 per cent. If you burn a little more coal you need not make any. Keep your cupola hotter and you can run it almost without any carbonic acid. You are to put the cost of the coal in the cupola as against the cost of lime in your boxes. If we have no sulphur, no ammonia and no carbonic acid worthy of consideration, what is the use of purification?

Mr. Nettleton—I must have been misinformed; but I think it is the impression among coal gas men generally that you cannot purify more than 6,000 feet of water gas (made by the cupola process) from sulphurated hydrogen with a bushel of lime.

Mr. Flemming—My experience is 2,500.

Mr. Bradley—We purify more than 2,500, but not more than 6,000; and it will run nearer to 4,000.

Mr. Nettleton—Is it because of the trouble with carbonic acid?

Mr. Bradley—Yes. Dr. Wilkinson is right in the statement which he makes about the quantity of carbonic acid. I was running 4,000,000 feet per day for six weeks with less than one per cent. of carbonic acid; but I found that in doing so I was burning more coal than I was saving in lime. So I finally established the rule of about from 2 to 3½ per cent. of carbonic acid as being about the balance between the coal and the purification.

Dr. Wilkinson—When I said that we made 5 per cent. in the water gas from cupola I meant that we were running then just about two-thirds water gas and one-third gas made from oil. Of course, there is no carbonic acid coming from the oil; and, consequently, this amount would be reduced by adding one-third more gas to it.

Mr. Humphreys—I think you said you made about 45,000 feet per ton of coal. Did you include the use of coal under your retorts?

Dr. Wilkinson—No; when I said that I was speaking about gas as a heating agent—as heating gas—where you take the amount of coal under the boiler and the amount of coal in the cupola. Putting those two tons of coal together you can make from each ton 45,000 feet. That has been measured.

Mr. Thomas—It is carbureted afterwards?

Dr. Wilkinson—Yes.

Mr. Thomas—I understood you to say that in making this gas you tried to get as much carbonic oxide in it as possible. What was that for when you admit that the CO is a virulent poison?

Dr. Wilkinson—The people must learn to take care of themselves. We tell them that the gas is made to be burned and not to be breathed. I was speaking of how much more we can make. By making so much carbonic oxide we, of course, make less carbonic acid. Now, there is something in the burning of the gas. If you have a gas that is rich in carbonic oxide you have a gas that is whiter than it is when made without the carbonic oxide; and it is so for purely a physical reason—the carbonic oxide burns with a blue flame, and the two burning together have a tendency to produce a white light. If you have them properly proportioned they will produce a white light. That is one reason why we get a whiter light by having the carbonic oxide than we do when we do not have it.

Mr. Nettleton—You made the statement that the ammonia in the gas is transformed into nitric acid. Can you show the chemical formula on the board?

Dr. Wilkinson—Take the old formula, NH_4O ; now, when that burns you will see that the hydrogen will burn into water, and the nitrogen at this high temperature is bound to take on oxygen and become NO_2 and NO .

Mr. Nettleton—But that does not necessarily make nitric acid, does it?

Dr. Wilkinson—Yes; it will always make more nitric acid than the lower oxides.

Mr. Nettleton—Why does it not make nitrous oxide?

Dr. Wilkinson—Because the temperature is too high. The oxidation is so rapid at that point. You can show it very well if you burn it in a glass jar. You may see the red fumes of NO_2 .

Mr. Nettleton—How much nitric acid can you produce from 5 grains of ammonia per 100 feet of gas?

Dr. Wilkinson—Taking the chemical equivalents, nitrogen is 14 and oxygen is 8, and 14 grains of nitrogen combining with 40 grains of oxygen will make 54 grains. That will be the atomic weight of the nitric acid— NO_3 . Now, when you have the ammonia you have not got to add

oxygen to burn it, so that 5 grains of ammonia would nearly equal 18 grains of nitric acid. The oxygen you get from the air.

Mr. Thomas—Natural gas is credited with being chemically combined in the proper proportions for heating purposes; and, in fact, it is claimed that none of the manufactured gases equal it in that respect. Some crude experiments which have been made, by simply taking air and carbureting it through the aid of oil, have determined that there is the same heating quality in that gas that there is in the natural gas, with a larger quantity of nitrogen and oxygen in it. It is a surprise to me how that can be.

Dr. Wilkinson—The hydrogen, weight for weight, gives the greatest amount of heat of any body. Here we have a more condensed gas; we have two equivalents of hydrogen, and we have carbon added to it. That virtually would be the same as the natural gas—and really it has more heating power than almost any other gas that you can get; but it has not so much as gas distilled from coal.

Mr. Thomas—The experiments which I have referred to were made in a crude manner, by simply taking the gas under pressure and delivering it from the same pipe, so that under the circumstances it was as nearly equal as possible. As the thing seemed, better results were obtained from the carbureted air than the natural gas.

Dr. Wilkinson—We can determine that without making any experiments, for we know how much oxygen will combine with hydrogen. Every pound of hydrogen requires eight pounds of oxygen for combination, and the heat developed in every case is in proportion to the amount of oxygen required to burn it. Now, if you will give me a body and tell me how many pounds of oxygen are required to burn it, I will tell you how much heat you will get from it. It is a positive quantity, right straight through. Carbonic oxide does not require half as much oxygen to burn it as hydrogen does. All that you have to do is to add one equivalent of oxygen to carbonic oxide and it burns it; whereas this gas carbureted hydrogen requires 3 equivalents of oxygen—or thrice as much. Carbonic oxide is a very poor heating body as compared with light carbureted hydrogen.

Mr. Humphreys—You spoke of the necessity of using dry steam. How does wet steam act?

Dr. Wilkinson—It simply puts out your fire, that is all. It deadens your fire right down. To decompose wet steam you require a very high temperature in your coal. I have made several attempts to get at the temperature, but I cannot say how high it is. It is a bright white heat when you start. The minute you begin to deaden that coal and bring it down to anything like a red heat, it will not decompose the steam. You see in the books a statement of the temperature that you have to have in the coal in order to decompose steam, but I find that possibly it is much higher than is there stated. I suppose we could decompose steam into carbonic acid and hydrogen at a temperature not much above a cherry red heat; but if you want to make it into carbonic oxide and hydrogen you have to have a higher heat. If the steam is the least bit wet you will soon deaden your fires, and you will find that during the 10 minutes you are passing the steam you cannot make anything like the amount of gas that you can if you have the steam dry. You need not necessarily have the steam at high pressure. All that you need is to have it dry. You know that we can have steam red-hot, and yet without a pound of pressure on it. You can heat steam as you can heat anything else—without having it under pressure. Suppose you have a long pipe, and that you heat it red-hot; you pass steam through it; you leave the end of the pipe wide open; the steam will come out of that end of the pipe just as hot as the pipe itself is. That steam will decompose very readily. In all our works it is heat that we are after. In order to make gas we must have heat—and heat at high temperature. Now, in making gas through our retorts I do not care how much heat you get on the bench; you may give me all the heat you can possibly obtain by a regenerator furnace, and I can pass gas enough through that to keep the heat down. If Mr. Flemming will show how we can burn hard coal under regenerator benches, I know where there is a place for 10 benches. Heat is what we are working for.

Mr. Flemming—I think you will get more heat there than you want.

Mr. Humphreys—You spoke of 80 feet to the gallon of oil. What was the candle power of that gas?

Dr. Wilkinson—We cannot separate that. That 80 feet is made in the presence of the water gas going through the retort. You cannot take that same amount of oil and put it through the retort and get 80 feet out of it in a way that will enable you to test it. It will only make 80 feet in the presence of the water gas, or hydrogen.

Mr. Strecker—What influence has the water gas upon it?

Dr. Wilkinson—In the first place, it keeps the particles moving. You can imagine the particles of naphtha are broken up into fine globules.

Now, aside from splitting up those particles, we cannot make gas without dropping something, and that something is carbon. Naphtha is made of carbon and hydrogen. As we decompose the naphtha and make gas out of the liquid, we have to drop something, and that something will be carbon. Now, as pure hydrogen is there, that hydrogen will seize upon that carbon to form a combination with the carbon, forming light carbureted hydrogen. I know that to be a fact. It used to be stated that there would be no combination between the free hydrogen and the carbon—that the carbon would drop. But this is not so; the carbon will combine with that free hydrogen. It is a principle in chemistry with which you are all familiar that if you want to produce a combination of bodies, one or both must be in a nascent state. Now, the hydrogen has already been produced in a free state, but the carbon which would drop out from the naphtha is in a nascent state, and the hydrogen will seize upon it and form light carbureted hydrogen. So that we get more light carbureted hydrogen in our commercial gas than we ought to get, and we get less hydrogen than we ought to have.

On motion of Mr. Benson a vote of thanks was given to Dr. Wilkinson.

A Method of Increasing the Consumption of Gas for Cooking and Heating Purposes.

[A paper read by Mr. F. G. Dexter, of Wantage, at the last meeting of the Southwest of England District Gas Managers' Association.]

It seems to be the orthodox rule in assemblies of this kind for the author of a paper or address to occupy the first five minutes or so in lamenting his inability to properly perform the task in hand, and calling the attention of the meeting to the fact. I believe that the final impression of this kind of thing is that the author himself would be about the last individual to sincerely believe it. At any rate, if he failed to demonstrate forthwith the diametrically opposite fact, his audience might be safely left to arrive at that conclusion in a much shorter space of time; for the fact remains that the aforesaid five minutes are generally more profitably spent by the members in arranging chairs, making a liberal use of the pocket-handkerchief, and a few other kindred attentions. As a new member of the Association, I am particularly conscious of the honor conferred upon me in the invitation to present a paper. Without apology, therefore, I give you—not a theory or proposition, but the actual results brought about by the adoption of a scheme (hitherto untried, I believe) to effect the subject of this paper.

On taking charge of the Wantage Gas Works last August twelvemonth, I found a state of things calculated to gladden the heart of any manager. To enumerate the difficulties encountered would afford scope for a lengthy paper in itself; and therefore I will content myself with briefly mentioning those bearing more immediately on the subject in hand. The annual output was about 8 million cubic feet, with a leakage of 20 per cent. The mains and services were allowed to look after themselves, until their existence was demonstrated in a more or less unpleasant manner. No record had been kept either of the position or age of the mains and services, whether forming part of the works or of the distributing system. The ideal depth seemed to be 6 inches, with two large firms manufacturing traction and semi-portable engines wholesale, with free license to turn the "kittens" into the street at will. All stores were purchased (I might have "obtained," but I can guarantee that they were paid for) from local tradesmen, who were also entrusted with the required repairs at the works, as well as all meter fixing and service and main laying. Under these circumstances, my first winter's experiences were particularly agreeable. Complaints from consumers were rife on all sides, from defective mains, services, and interior fittings, although, of course, "the gas" was the scapegoat; and as this was sent out well purified, and of 17-candle average quality, it was hard to bear without the means of putting the actual defects right, except at great expense with insufficient workmen, and only at such times as might suit their employers' purposes.

By the close of October I had had enough, and at the next Board meeting (on Nov. 5) I introduced a report condemning the whole system; proving the indifferent and costly way in which fitting work and repairs, both for ourselves and the customers, was carried out, and advocating thorough reform, including—(1) Additions to the staff for stoking and yard work. (2) The engagement of a thorough mechanic and fitter. (3) Power to hold an exhibition of cooking, heating, and lighting apparatus in the Town Hall during the following summer. (4) Full license to hold the necessary stock and stores of apparatus and fittings, and to let cooking stoves out on hire. (5) To undertake gas-fitting in any shape or form which might appear advantageous. (6) To lower the price of gas used for cooking and heating purposes, ex-

cepting by the use of boiling-burners only, by 10d. per 1,000 cubic feet (from 4s. 2d. to 3s. 4d.). I will not attempt at this time to describe the meeting; suffice it to say that my report was adopted.

The exhibition was held from the 18th to the 21st of June (four days). This was, I suppose, of the usual character. At the head of the room a lady lecturer demonstrated twice daily on plain and fancy cooking; including on one evening the preparation complete of a five-course dinner for five or six persons. A test meter, facing the audience, was fixed to record the consumption of gas in the stove used; the cost being given at the close of the lecture. Opposite, at the bottom of the hall, eight different sizes of ranges were shown, both enamelled and plain; while on either side were arranged a variety of other apparatus—including fires, bath-heaters, boiling-burners, coffee-roasters, airers, washing machines, grillers, &c.—any of which could be instantly lighted up. Arranged round the walls on brackets were various types of lamps and burners, illustrating flat-flame, Argand, and regenerative lighting. Pamphlets and papers were widely distributed, and posters adorned the walls. Specimens of some of these are on the table for the inspection of any who may be interested. Admission was entirely by invitation ticket. I may here mention that the whole of the cooking and heating apparatus exhibited were Messrs. T. Fletcher & Co.'s, and that I have kept exclusively to that firm's manufactures.

To my mind it is of primary importance that a gas company's goods and work should be second to none. For this reason I will supply no other form of globe than the improved open bottom, and no other than the governor type of burner. The small galleries attached to brackets, etc., supplied from the manufacturers, are removed and thrown away. It is high time gas companies with fitting businesses combined to put pressure on manufacturers to stop, or at any rate to limit, the sale of these abominations. At present they are supplied with every bracket and chandelier manufactured as part cost; and customers naturally object to give up an article once paid for to incur the expense of a second.

The exhibition being held so late in June, little fixing of apparatus could be effected before the close of the quarter. From then, however, until now the work has rapidly proceeded; my fitter, until a few days ago, being on overtime until 8 and 9 at night. At the close of the exhibition, some 25 appliances were on order; while up to the present time upwards of 60 (omitting boiling burners, etc.) have been fixed. This record, out of some 200 consumers, speaks for itself. A great deal of ordinary fitting work has also come in; and I see no reason to doubt the continuance of public favor and confidence. The net effect has been to return to us the whole of the extra wages, while we have also effected all our own main and service laying, meter fixing, and tool and general repairs.

It is our practice to let out on hire cooking stoves only—the rental varying from 1s. per quarter for a stove suitable for four persons, to 3s. 3d. per quarter for one to cook for 15 or 20 persons, and the minimum term of hire being 12 months; but they are sold to consumers at a discount of 33½ per cent. Fires, bath heaters, and all other apparatus, are supplied at 25 per cent. discount.

In fixing gas appliances I charge cost price, and sometimes under, for those which affect the day consumption; and in all other cases allow for an ordinary profit. Every case of gas fitting I personally inspect beforehand; instruct my man respecting the work, if necessary, and inspect again both while in progress and after completion. Should any difficulty subsequently arise, it is always put right without further expense to the consumer. Every opportunity is also taken to instruct consumers in the proper use of any apparatus they may have. By this means satisfaction has ruled the day; and although it has necessarily entailed a great sacrifice of leisure time on my part, I feel that the results have well repaid the labor and risk.

In connection with my report to the Board I mentioned a reduction of 10d. per 1,000 cubic feet for gas used for cooking and heating purposes. With gas at 4s. 2d., and no immediate prospect of a reduction on ordinary ground, I felt that a secondary and lower rate was essential, in order to popularize the exhibition movement, and give a decided impetus to the consumption. You will the more readily understand this when bearing in mind that Wantage is supposed to be the oldest town in England, and now only numbers about 4,000 or 5,000 inhabitants; so that the prospect of the growth of the consumption of gas for lighting purposes by the influx of new consumers is not reassuring.

Some here may consider the drop of 10d. per 1,000 feet too great under the circumstances, or may, perhaps, entirely discountenance a secondary rate. I do not. What is more, I believe that, however good the results due to the exhibition movement in any town may be, that a lower rate for heating and cooking gas would pay better. A consumer seems naturally to expect a reduction. The use of gas for cooking and heating

purposes is very young compared with its primary function—lighting, and some incentive, some inducement to try it for other purposes should be offered. The very fact that gas is delivered at less cost to us should influence the question. Take a consumer adopting some apparatus; the consumption is always largely increased, and often doubled. What does that gas cost the distribution department? Nothing. You use the same main, the same service and the same meter. The leakage is unaltered, unless the pressure is augmented; but the bulk of such gas being used in the day affords little excuse for that. In my own case the works are the property of the town. No surplus profits are made; the selling price (4s. 2d. per 1,000 feet) being practically the cost of working and delivery to the consumer under our circumstances. Say, for argument's sake, our leakage is 10 per cent. It is known well enough that services cause the bulk of the loss from leakage; and each service presumably goes to a consumer. Therefore all extra gas delivered through such service, being free from leakage, costs us one-tenth less. It can be sold at 3s. 9d. per 1,000 feet apart from any question of increased economy in production at the works, which every manager knows must follow.

With a differential charge for gas, therefore, the question arose as to how the relative quantities used for heating and lighting respectively were to be determined. I was aware of the double-index meter system, and also that separate meters might be put in to take the cooking and heating consumption. But neither plan commended itself to my mind, on account of the expense involved, and the difficulty in the latter case of inducing consumers to face the outlay of the duplicate service. After careful consideration, I determined to try the following plan: In the great majority of cases the consumption of any individual consumer for lighting purposes remains fairly uniform from year to year; the consumption for any particular quarter comparing pretty closely with that for the corresponding period of the previous year. At any rate, should any fluctuations occur in the shape of an increase, they are not slow to require an explanation. Taking, therefore, the four quarters ending March 25, 1889, as the basis for lighting purposes, it was agreed that the adoption of any stove, fire, or other apparatus, would necessarily make the total consumption greater; and that whatever increase there might be in each quarter over and above the four quarters to March 25, 1889, should be chargeable at the lower rate. The effect of this is that a great many consumers have adopted some kind of appliance who would not have entertained the idea had a duplicate service and meter rent been necessary, to say nothing of the horror some have of the idea of the house being turned upside down "for those gas men." Again it is a direct incentive to a more liberal use of gas for lighting purposes; this extra consumption of course going in at the lower rate. In the case of an account heavier than usual—from late hours, inclement weather, or what not—it is useful to be able to point out how much heavier it might have been had not the consumer adopted some apparatus, and so become entitled to have all the increase charged at the lower scale. On the other hand, since no reduction is allowed except on an increase over the 1889 consumption, the works are protected from a diminution of income from these consumers, as far as it is possible to go; so that in the case of a consumer adopting, say, the albo-carbon light, the reduction on the lighting consumption has to be made good by a part of the heating consumption—the balance only coming in at the lower rate. But in other words, a consumer effecting economy in his lights gets the reduction on the consumption charged at the heating and lower rate first, and not until the whole extra consumption of a fire or stove has been wiped off, can the actual lighting rate be affected. Of course, this in some cases makes the cost of the fire or stove appear remarkably small. The consumer, however, in getting such conveniences so cheaply is well satisfied; and so am I. In the case of new consumers, duplicate meters and services are generally put in; but in some cases they prefer the account to be proportioned by us. In such instances, while dealing as fairly as possible, you may be sure my award does not unnecessarily prejudice the legitimate income of the works, nor make the cooking and heating figure appear too costly.

Such, then, is the plan adopted; and to complete this paper, and justify the steps taken, I have only to give you the result. Although the appliances were being fixed during the September quarter, and consequently had not developed the full effect we shall experience in the future, our registered consumption for that period is 30 per cent. higher. Appliances were being fixed at intervals through the Christmas quarter; and although it is with us by far the heaviest quarter for lighting purposes, yet the registered consumption was up 15 per cent. The total quantity of gas registered for heating and cooking apparatus in the Christmas quarter was 36 per cent. in advance of our September figure; and I therefore believe that another summer quarter will give us a 40 per cent. advance. I am sorry this meeting is being held a little too early

to enable me to give the exact figure for the present March quarter, which closes in a fortnight's time; but from my books I find the increased output well maintained, and expect that if any difference is found it will be still higher. I would add that the output is really greater than the figures given. Several new consumers have been obtained, and the public lighting greatly augmented by the adoption of Sugg lamps in the Square, and other improvements; but the figures given are purely the exhibition of results.

This, gentlemen, is all I have to say on this subject at present. The scheme of arranging the consumption is, I believe, a novel one. Whether or not it is applicable to large towns I leave to the judgment of those engaged in them. It is, I think, well enough adapted to small places with limited capital and stunted growth; while the excellence of the results can hardly be questioned. The paper is offered primarily to put heart into those managers who have not yet dared to move from the customs of bygone days, or "to brave the lion in his den" over that bone of contention, the "gas works fitter," and the little tit-bits of income one meets with. To those I would say that, if no opposition were offered, one could be sure there was little to be gained. Go and do likewise, is my advice. There are doubtless others who have long since successfully engaged in the work. If any such can find in this narrative food for reflection, or some stray new idea, so much the better. The best among you can at least leave with the pleasing reflection of how much better he has done.

Cowell's Device for Carrying off Leakage from Gas Mains.

On April 8th U. S. Letters Patent (No. 425,369) were granted to Hiram Cowell, of Zanesville, Ohio, for a device or system for carrying off leakage from gas mains. In the drawings Fig. 1 is a side elevation of a section of a gas main, showing the covering on the joints and the escape pipe for carrying off any gas that may leak out; and Fig. 2 is a longitudinal sectional view of one of the joints, showing the manner of adjusting the escape pipe.

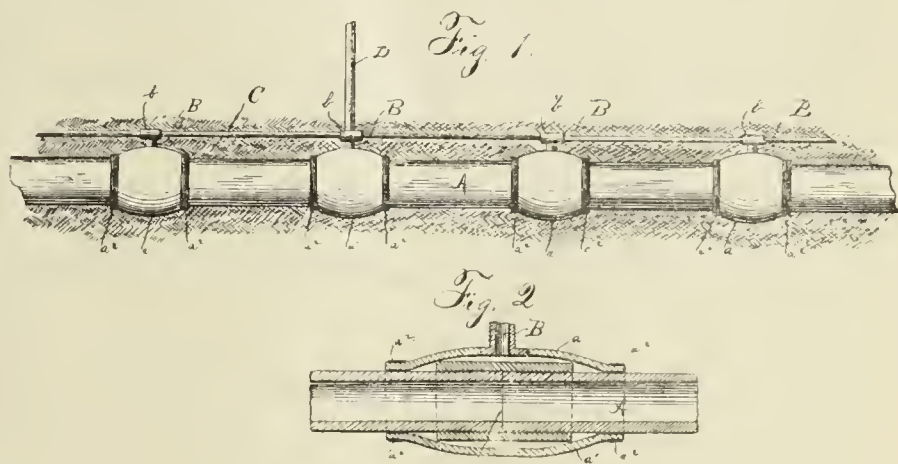

A designates a main such as is usually employed for conveying gas through the streets in cities. Around each of the joints *a* is placed a covering *a'*, which may be of any elastic material, but preferably of rubber. The covering may be made in the shape of common hose, in which case it would simply be slipped over the joints and cemented and held in place by means of a clamp, or by wrapping wire around it at each end, as shown in the drawings at *a''*. This would prevent the escape of gas at the ends, and cause it to escape through the pipe *B*, which extends through the covering and to within a short distance of the joint. To each of the pipes *B* is secured a T-joint *b*, into which is fitted a pipe *C*, which connects all of the escape pipes *B* all along the main. At long intervals in the length of the main are other escape pipes *D*, which allow the gas to pass out into the air.

In covering very large mains it will be found very difficult to obtain rubber tubing of sufficient diameter to slip over the mains. In that case sheet rubber may be used and the edges and ends cemented to prevent the gas escaping.

This device may be also applied to the smaller gas pipes in a house, and also to prevent the escape of sewer gas.

MR. DAVID MORRIS, formerly in charge of the works of the New Westminster (British Columbia) Gas Company, is engaged in the construction of the new water works at Moscow, Idaho, the franchise for which was secured by Mr. G. H. Sutherland, of Walla Walla, Wash. The works are to cost \$25,000, and are to be completed on or before July 1st.

SPECIAL ENGLISH CORRESPONDENCE.

COMMUNICATED BY NORTON H. HUMPHRYS.

SALISBURY, April 10, 1890.

An Important Problem.—The Gas Institute Meeting.—The Profits of Electric Lighting.—Oxygenated Oil Gas.—Spontaneous Combustion of Coal.

The question of the effect of a moderate dose of air, say not exceeding 2 per cent., admitted at the inlet of the purifiers, upon the illuminating power of the purified product, is one possessing great interest. There is no doubt as to its benefit in prolonging the active life of the charge of material, whether oxide or lime, and thus reducing the expense and the annoyance involved in a change of the contents of a purifier; but opinions seem to differ as to the effect upon the illuminating power. In my own practice, the proportion of sulphureted hydrogen remaining in the gas by the time the inlet of the purifier is reached, is reduced to about 5 grains per cubic foot by careful and thorough washing and scrubbing. About 1½ per cent. of air admitted at the inlet of the exhauster is sufficient to maintain the *in statu quo* of the oxide purifier, as it is assisted by the small proportion of oxygen already present in the crude gas, and the most searching experiments fail to show any effect, deleterious or otherwise, exercised by the air upon the illuminating power. Several other gas engineers, who also carefully measure in a small quantity of air, find their experience to agree with this; but there are some who insist that air cannot possibly be united with the gas without exercising a deteriorating effect similar to that observed when air and ordinary purified gas are united together.

That the use of the above small proportion of air admitted under the circumstances usually prevailing in a gas works, at some point anterior to the purifiers, may be resorted to without any injurious results, is therefore a proved fact, so far as some gas works are concerned, at any rate. But the explanation of this fact is a matter of conjecture only at present. The only observed data is that the air increases the temperature of the purifying material to the extent of a few degrees. A charge of purifying material certainly absorbs hydrocarbons from the gas. As much can easily be shown by experiment. And it is easy to imagine that, especially where the purifiers are exposed to a low temperature, that a few degrees of warmth may materially reduce such absorption. I question whether it is due to any special chemical property of the material. The effect of a sudden cooling is sufficient to account for it. We are always very careful to guard the gas against "shock" in the way of a sudden reduction in temperature while in the condensers. But if such gas, after being condensed and washed by appliances situated in a sheltered locality near to the retort house, is conveyed to a purifier house at some distance and in an exposed place, it may perhaps enter the purifier at a temperature of 10° or 20° higher than that of the material. The sudden and complete chilling that follows upon the intimate contact with a large surface of cold material would then produce those effects that have been so carefully guarded against in the condenser. Of the 1.5 per cent. of air, we know that the whole of the oxygen is absorbed and retained in the purifiers, leaving only 1.2 of nitrogen to pass on with the gas. It has recently been suggested that a portion of the nitrogen may also be retained. When alkalinized carbon at a high temperature is exposed to air and steam, some of the nitrogen is retained in the form of cyanides. A considerable quantity of cyanide accumulates in oxide of iron used for the purification of gas, and it is also possible that some of the nitrogen may remain as ammonia. If the nitrogen is retained in the purifier it cannot, of course, injure the gas in any way.

The reason for referring to this subject is because I notice, from the reports of American Gas Managers' Associations, that some of the members are experimentally inclined, and in these days when we are all perturbed at one time or another as to "what to write a paper about," a suggestion may not be unacceptable. Unfortunately there is no convenient method by which the percentage of nitrogen present in a gas can be directly and accurately determined. But as the specific gravity of nitrogen is more than twice that of coal gas, a few experiments with a delicate specific gravity apparatus, such as the Lux balance, would soon afford some information as to the quantity of nitrogen remaining in the gas. Other methods of proceeding will also be obvious to those who are interested in this question. The purifying materials, for instance, might be examined for nitrogenous products.

The arrangements for the June meeting of the Gas Institute, which is to be held at Ryde, Isle of Wight, are in a forward state. Seven papers have already been promised by gentlemen whose names are quite sufficient to show that the prestige of the Institute, as compared with its previous proceedings, will be fully maintained. A noticeable feature of the

programme, and one that will no doubt prove a great attraction, is that of the seven papers above named no less than four are devoted to new inventions of an important character. Mr. W. Gadd will describe the Northwich gasholder, as erected according to his patent system, without exterior guide-framing of any kind; Mr. Pease has something to say about his wire rope system of guiding gasholders; Mr. Coze, of Rheims, will treat of his well known setting of inclined retorts; and Mr. T. Duxbury will read a paper on the Dinsmore process. Looking at the activity that has lately prevailed in respect to oil and water gas, something on these subjects should also be forthcoming. In any case, however, there will be plenty of useful material for discussion. Mr. Geo. Garnett, of Ryde, is the President, and his name is a sufficient guarantee that the social and recreative part of the gathering will be efficiently provided for. Few people know how to arrange for the comfort of a party, whether of 600 or 2,000, better than Mr. Garnett.

The supply of electricity for lighting purposes is not yet a paying affair. The London Electric Supply Association have a plant that cost a round quarter of a million sterling. During the past year it was the means of earning them about £26,000 as gross rental. Of this nearly £20,000 was required to cover the cost of coal, oil, wages and repairs at the generating station. Coal cost £10,500, which is a much larger proportion of the revenue than obtains in the case of coal gas. That sum expended in gas coal would be the means of producing £50,000 or £60,000 worth of gas. Oil and waste cost £2,750, which shows that the machinery requires a tremendous lot of lubricating and cleaning. After paying distributing and other charges a balance of £1,250 remains as profit, which is equal to one-half per cent. on the capital. No wonder the electric light people show such a marked preference for dealing in sales of concessions and patents, or the supply of apparatus. I shan't buy any electric lighting shares at present. No, thank you. Six per cent. gas securities suit me better.

The supply of pure oxygen gas at low prices, now rendered practicable by Brin's Oxygen Company, has directed attention to the various methods in which it can be applied in practice. Amongst other things, it has probably been the means of originating the oxygenated oil gas scheme. Oxygen in quantity has a considerable depreciating effect on the luminosity of ordinary coal gas, but it is claimed that this objection diminishes as the quality of the gas increases. It should be understood that the oxygen is to be used in quantity considerably less than that necessary to form an explosive mixture. A rich oil gas, of 80 to 100 candle power, is very apt to smoke, even with every precaution in burning; but the addition of 20 per cent. of pure oxygen to such gas is claimed to be a means of overcoming this difficulty without at the same time lowering the illuminating value. The oxygenated oil gas thus formed is a sort of concentrated coal gas, yielding five or six times as much light. One thousand cubic feet of it is therefore equal in value to 5,000 or 6,000 cubic feet of coal gas, and the intrinsic value of it, taking the latter at 60 cents per 1,000 cubic feet, would be over \$3. At this price the mixture would afford a large profit, as, with the prices of oil and oxygen at present prevailing, it would not cost more than \$2 per 1,000 cubic feet. The scheme, however, appears to be applicable on the small rather than on the large scale. It may overcome the difficulty of burning rich oil gases, but it does not touch upon the difficulties connected with their distribution to any distance. Provided that the claims of the inventors can be realized in practice, something more will be heard of this scheme in connection with the supply of gas to lighthouses, gentlemen's country residences, or factories situated in districts where coal gas cannot be obtained at a moderate price.

A paper on the spontaneous combustion of coal was recently read before the Institution of Naval Architects, and it is worthy of careful study by all who are interested in the storage of large quantities of coal. The author is Prof. Vivian B. Lewes, who is known as being at present engaged upon an investigation of Van Steenberg's water gas. The principal cause of spontaneous combustion is defined in the following terms: "When the carbon of the coal absorbs oxygen (from the air), the compressed gas becomes very chemically active, and soon commences to combine with the carbon and hydrogen of the bituminous portions, converting them into carbonic acid and water vapor." The prevalent idea is that the presence or otherwise of pyrites or brasses is largely concerned in determining the liability to spontaneous combustion. But it is shown in the paper that the heat produced in this manner is far too small to raise the coal to igniting temperature, or anything near it. The igniting point has been carefully determined by the author, and found to range from 700° F. for cannel to 870° for anthracite. A fruitful cause of spontaneous combustion is the manner in which coal is treated previously to stacking, which usually leads to a large amount of disintegration and consequent formation of fresh surfaces for ex-

posure to the air. Coal loaded into trucks is frequently conveyed some hundreds of miles by rail, being exposed to a great deal of rough jolting during the act of shunting, etc. It is then shot violently down a slope into the hold of a ship. The large amount of slack and dust thus formed is usually the source of trouble, as it not only offers additional facility for the absorption of oxygen, but is a great hindrance to ventilation. If coal was stacked without all this rough treatment, in the same mechanical state in which it is taken from the pit, there would be no risk of firing. As an indication of rise of temperature in the stack of coal, the introduction of electrical alarm thermometers at suitable intervals throughout the mass is recommended. These could be set to ring a bell as soon as a certain temperature was reached, and the bell would continue to ring until the temperature was reduced below the limit. A safeguard against undue rise of temperature could be provided by the use of steel cylinders 1 foot long by 3 inches in diameter, containing carbonic acid compressed to several hundred atmospheres, and closed by a fusible plug melting at 200° F. As soon as the melting point of the plug was reached the carbonic acid would escape rapidly, and in the act of expanding would absorb a large quantity of heat. Prof. Lewes claims that one such cylinder to every 8 tons of coal would be an absolute preventative of undue rise of temperature. According to this, there need be no more trouble or loss on account of the spontaneous combustion of coal cargoes.

ITEMS OF INTEREST FROM VARIOUS LOCALITIES.

THE Walla Walla (Wash.) Gas and Electric Company's new buildings for the housing of its incandescent electric lighting system are well under way.

SUPERINTENDENT EDWARDS, of the San Jose (Cal.) Electrical Improvement Company, has, through frequent tampering by unknown parties with the Company's wires and lights, been compelled to offer a reward of \$250 for the arrest and conviction of the offenders.

THE Drain National Gas Company has been incorporated by Messrs. C. M. Idleman, M. C. George, F. A. E. Starr, R. L. Durham and Geo. B. Markle, with a capital stock of \$100,000. This place is in Douglass county, Oreg., at a point 229 miles north of Portland. It is on the line of the old Oregon and California Railroad.

"I SEND you the following resolutions that were recently adopted at a special meeting of the stockholders of the New Bedford (Mass.) Edison Electric Illuminating Company. This move puts Mr. Taber's Company in complete control of the artificial lighting supply of his city—perhaps I should have said the artificial lighting supply on a wholesale basis, for it is beyond question that a few candles and some quantities of 'oil' are still retailed in the celebrated old whaling port. The resolutions are: 1. That this corporation sell its real estate, licenses, privileges, rights and franchises, together with so much of its other property, machinery and material as will altogether amount to the sum of \$150,000, valued as the same stands upon the books of the company, and receive in payment therefor 1,275 shares of said New Bedford Gas Light Company, reserving, however, the corporate power to wind up and dispose of its assets not herein conveyed. 2. That the President and Treasurer be and are hereby authorized to execute, acknowledge and deliver in behalf of the corporation all deeds, papers and instruments necessary to carry out said sale. 3. That John W. Macomber and Chas. R. Price be appointed Trustees of the corporation and of its shareholders to receive from the New Bedford Gas Light Company the shares of stock to be paid by said New Bedford Gas Light Company as the consideration of the sale heretofore voted, and to distribute the same among the stockholders of this corporation in proportion to their respective interests, and to sell at public auction so many of said shares so received from the New Bedford Gas Light Company as may be necessary to an equitable distribution of the same. 4. That the Directors be authorized to take such action with reference to all assets and liabilities of the corporation as are not sold to the New Bedford Gas Light Company under the provisions of the vote heretofore passed, for the purpose of winding up the affairs of this corporation, and distributing the remaining property among its shareholders, as they shall deem best for the interests of said shareholders."—OBSERVER."

"SAN FRANCISCO, Cal., April 14th, 1890.

"Dear JOURNAL—The trial of the action brought by Simon Goldstein and Hernian Cohn against Messrs. Will & Finck to recover \$1,050 for an alleged theft of gas, was begun, on the 13th inst., before Judge Hunt and a jury. The complaint in the case sets forth that the defendants are doing business at 818 and 820 Market street, and the plaintiffs, in the ad-

joining shop, at 822 Market street, carry on their trade. It is charged that for 10 months past defendants secured the lighting of their stores free of expense by secretly attaching their pipes to the plaintiffs' meter, thus securing gas for 52 lights of the value of \$2 a night. The plaintiffs claim to have sustained \$1,000 actual damages, and also that they have expended \$50 in endeavoring to discover the unlawful connection. I have heard of gas being stolen from gas companies, and often burned off the same meter, but this market street instance strikes me as an entirely new sample of 'gas steal.' In that belief I venture to send the above facts.—RETORT."

THE first move in the shaping up of the future management of the Troy (N. Y.) Electric Light Company, since its acquisition by the Troy Gas Company, is the election of Mr. Charles E. Davenport, Secretary of the Gas Company, to succeed Trustee George H. Morrisson, of the Electric Company. Doubtless the next one of the new owners to assume a Trusteeship will be Mr. A. N. Brady, and in all probability he will replace Mr. Chas. P. Kimball.

MR. L. F. McDONALD, Mayor of Belfast, Me., notifies electric lighting contractors that the City Council will, until 6 P.M. of Monday next, receive bids for the public lighting of that place, under the following conditions: 40 incandescent electric lamps, of 64-candle power each, and 6 arcs of 1,200-candle power each, the lights to burn from sunset to midnight of each night in the year. Proposals are invited for a 1, 2, 3 or 5-years' contract, and also for a service based on all-night lighting. Again, proposals will be received for 20 arcs, to be burned from sunset to midnight throughout the year. The party to whom the contract is awarded must have the lights in duty 90 days after the contract is signed.

THE stockholders of the Randolph (Mo.) Coal and Gas Company have agreed to increase the capital stock to \$200,000 from \$75,000.

THE officials of the St. Paul (Minn.) Gas Company entertained at least 500 people at the premises No. 100 East Third street, that city, on the afternoon of the 16th inst. The entertainment was somewhat after the nature of a lesson in cooking, differing therefrom only in the fact that the edibles cooked were afterwards (at once would be better) consumed by the visitors in attendance. Of course, the cooking was done by gas in gas ranges, boilers, heaters, etc., and there can be no doubt about it that this object lesson will be worth at least \$5,000 in good, hard cash to the St. Paul Company, ere 1890 becomes 1891.

AT a meeting of the Board of Directors of the Charleston (W. Va.) Gas Company, held on the 16th inst., it was agreed that the Company should erect an electric light plant at once, and operate the same under the authority conferred by the Company's charter.

"I NOTE your reference to the possibility of Manchester, Va., having a gas works, and agree with you that the possibility is likely soon to become a certainty. In connection with this I send you the following from a local paper known as the *Leader*, dated the 12th inst.: 'Mr. John C. Robertson, on behalf of himself and others, presented a petition to the City Council last night asking for franchises to construct a gas plant in Manchester for the purpose of manufacturing illuminating and fuel gas. The petition came in the shape of an ordinance reported from the Committee on Light. The ordinance provides that mains shall be laid on the same streets now occupied by water pipes, and on such other streets as the Council may direct, certain conditions being complied with. It is provided that the city shall receive gas at not exceeding \$1 per 1,000 feet, and the citizens shall not be charged in excess of \$1.25 per 1,000: further, that when the price of gas in other cities east of the Alleghenies is less than \$1.25 a similar reduction shall be made here. The Company is to enjoy exclusive franchises for a period of 25 years. In the debate that followed Chairman O'Brien, of the Committee on Light, said he did not expect the ordinance to be adopted right away, and agreed with others that it should go over for a few days. Mr. Bradley thought the 25-year exclusive feature was too lengthy a concession, which view was shared in by Messrs. Perdue and Falconer. It also looked as though the sentiment of the Council was in favor of stipulating in the ordinance that the city should have the right to at any time purchase the plant.'—R."

THE new Collins Cove and Beverly Harbor plant of the Salem (Mass.) Gas Company, which is complete in every particular, is now in active operation, and is a success in every way you can ask the question.

SOME months ago we published an opinion of the District or Lower Court of New Orleans in the matter of the New Orleans Gas Light

Company vs. the Harmony Club, in which the basis of claim was that defendants resisted payment of a bill for meter rent, presented by the plaintiff. The latter had been using gas but subsequently changed to electricity, insisting nevertheless that defendant should not remove the gas meter, and that payment to the plaintiff should only be made for such gas as was passed through the meter when the electric light failed, etc. The decision of the inferior court was adverse to defendant, who thereupon applied to the Supreme Court for an appeal, with the following result—in view of the importance of the case we report it in full. The decision was rendered by Judge Fenner, the associates concurring: "*Harmony Club vs. New Orleans Gas Light Company*.—Appeal.—We are confronted with a challenge to our jurisdiction, *ratione materiae*, over this appeal which we are bound to determine. The facts are simple and undisputed. The Harmony Club had upon its premises, furnished by the Gas Company, what is called a 45-light meter, adequate to the supply and registry of all its gas burners. In common with many other gas consumers it adopted the system of electric lighting and its use of gas became only occasional and greatly reduced. The Gas Company adopted certain rules applicable to this class of customers, the meaning and effect of which are that it would only furnish meters proportioned by size to the amount of gas consumed. That a 45-light meter would only be supplied or continued when the monthly gas bill was at least \$8; or if less, upon the payment of an extra rental of \$4 per month. A copy of these rules was served upon the Club, and notice was given that unless complied with its meter would be removed and replaced by a smaller one. The Club being unwilling to comply and denying the right of the Gas Company to adopt or enforce such rules, instituted this suit for an injunction prohibiting the latter from removing or interfering with the meter then on its premises. The Gas Company responds, affirming its right to adopt and enforce the rules in question. This is the sole issue involved in the case. If it should be determined that the Gas Company has the right to adopt and enforce the rules, the injunction necessarily fails. If *per contra* it has no such right the injunction stands. What is the amount or pecuniary value involved in such a suit? It is not pretended that the Gas Company will interfere with the meter if the Club consumes gas to the amount of \$8 per month, or, if consuming less, it pays \$4 additional for the rent of the meter. It is not denied that the club is bound to pay for the amount of gas, large or small, actually consumed by it. Therefore, the only value possibly involved is the right of the Company, in a certain contingency, to charge \$4 per month for the use of its meter, or \$48 per annum. If this were a right *in perpetuus* it would be difficult to find an investor who would pay \$2,000 for the privilege of collecting \$48 per annum; but in point of fact, the Gas Company's charter expires in 35 years, and a simple calculation would show that if collected in that period the gross amount would not exceed \$1,700. Moreover, the Club is not the owner of the building, but a lessee, and is only interested during the term of its lease, the extent of which is not shown, but is presumably limited. We are not concerned with the damage which the Club might have suffered had its gas supply been cut off or diminished, as threatened. No such damages have accrued or will accrue. If the injunction herein be perpetuated that will prevent such injury. If it be dissolved the act of the Gas Company will be declared lawful and no such claim can arise. We have repeatedly held that the jurisdiction of this court must be tested in such cases by the pecuniary amount or value in dispute, according to the nature of the action as disclosed by the substantial allegations of the pleadings, and not by the mere jurisdictional allegations or affidavits of the parties—*Belding vs. Baldwin*, 38 Ann., 394; *State ex rel vs. Miscar*, 34 Ann., 834; *Wilkins vs. Gault*, 32 Ann., 929; *Cran Case*, 32 Ann., 1,191. Most of the cases quoted by appellant only concern the right to sue and enjoin, neither of which rights is controverted here. We decline to follow him into the records of the cases of *Callory vs. Water Works Company*, 35 Ann., 799; *Long vs. same*, 36 Ann., 942; and *Ernest vs. same*, 39 Ann., 551, in order to determine whether or not we had jurisdiction in these cases. The opinions show that no such question was raised or passed upon. Had it been we should have applied to them the same rules now stated. If inadvertently and in the absence of suggestion to that effect, we exercised jurisdiction which we should have declined (which we by no means admit), such error neither harms nor benefits the plaintiff here, whose right must be decided according to law. It is therefore ordered that this appeal be dismissed at appellant's cost."

THE deadlock over the election of a President for the Bridgeton (N. J.) City Council has been brought to a happy termination in the selection of Mr. Benjamin F. Harding, of the Bridgeton Gas Company. The mantle could not have been placed on worthier or stouter shoulders.

MR. JAMES LAMBERT VIALLE, one of the most popular collectors in the service of the Bay State Gas Light Company, of Boston, Mass., died at his home in that city, on the 16th inst. He was in his 62nd year, and was well liked by his employers.

THE betterments recently completed on the plant of the Danvers (Mass.) Gas Light Company have enabled it to distribute an excellent quality of gas. The last test made by Inspector Hinman gave it a candle power of 18.1, and the ammonia content was less than 2 grains per 100 cubic feet.

THE Waltham (Mass.) Gas Light Company is extending its mains, and the business of the Company keeps on increasing in most gratifying manner.

THE Citizens Gas Light Company, of Newark, N. J., is not averse to bringing on a lawsuit in respect to its right to remove gas meters from the premises of those who have changed from gas to incandescent electric lighting, but who insist on retaining their gas meters as an insurance against possible failure of the electric light. Early this month the Company did remove a meter from the barber shop of F. Beck, 9 New street, whose use of gas was confined to a quantity sufficient to maintain a cigar lighter. The barber agreed, however, to pay for a certain quantity of gas each month, and his meter was replaced. The Company, however, intends to have a test case of this right made, and, judging from the rulings in the Supreme Court of Louisiana, in respect to the complaint of the Harmony Club, there is small doubt that the right would be sustained.

MR. WM. BRUCE, of the Elmira (N. Y.) Gas Company, will visit Europe this summer. He expects to remain abroad for four months.

THE new gas rate at Rockford (Ills.) is \$1.80 per 1,000. The American Gas Company are to be congratulated on their having secured this property, which so long stood as a monument to the genius of the late Thomas Butterworth.

AT the annual meeting of the Flint (Mich.) Gas Light Company the following Directors were chosen: J. W. Begole, Ira H. Wilder, Wm. Hamilton, Wm. A. Atwood, J. C. Wilson, A. D. McColland and Robt. J. Whaley. The officers chosen were: President, J. W. Begole; Treasurer, Ira H. Wilder; Secretary, Giles N. Denham.

THE Poughkeepsie (N. Y.) *News Press* says: "The Electric Light Company are not furnishing good service in the government building here. They are obliged by the terms of their contract to pay for all gas used in the post office and in the revenue collector's office, in consequence of the incandescent lamps failing to give sufficient light. The gas bills on these accounts have been frequent and large of late. Further, the incandescent electric lights in the post office building do not come up to the standard of 16-candle power."

THE County Board of Equalization has reduced the assessment of the Kansas City (Mo.) Gas Light and Coke Company on personal property from \$160,000 to \$107,000, because it was shown that the Company returned its machinery—retorts, scrubbers, etc.—as personal property, while the Board had also assessed the same under the heads of buildings and contents.

THE attempted general strike at the North Side works of the Chicago Gas Light and Coke Company was a complete failure. Only 7 of the employees went out. The proposed strike was ostensibly based on the discharge by the Company of Richard Williams and Charles Peters, their confreres claiming that the men had been discharged without just cause; but the real cause for discontent is the desire of the men to have fewer hours of work.

DISPATCHES from Circleville, O., bring the news that Howard Jones, Henry Worthington, George C. Harrington, Fannie M. Moore and Samuel Moore have filed a petition in the Common Pleas Court praying that the Circleville Gas and Coke Company be put in the hands of a receiver and its affairs closed up. They alleged that the defendants, L. H. Sweetman, Jos. P. Smith, B. Hathe and L. Abt, owners of one-half of the Gas Company's stock, are also stockholders in the Circleville Edison Electric Company, and that they use the information so obtained to the injury of the Gas Company.

THE Legislative Committee appointed by the Kentucky Senate and House to investigate charges that the Louisville Gas Company had interfered in local elections, seems to make haste slowly. At any rate, they have named two dates on which to take testimony at the Galt

House, but the announcements were followed by postponements. Among the witnesses cited are: President Morris, Vice-President Barret, Treasurer Lee, Asst. Treasurer Porter, Directors Harry Bishop and J. M. Atherton, Gas Inspector Bate, Ex-Mayor Reed, Mayor Jacobs and other city officials.

LAST week we noted that the stockholders of the White Plains (N. Y.) Gas and Electric Light Companies had voted to consolidate their interests, and we are now able to say that the deal is a fixed fact. The officers chosen are: President, Samuel Conover; Treasurer, Edward R. Phelps; Secretary and Superintendent, Richmond E. Slade; Directors, S. Conover, Edward R. Phelps, Samuel R. Pullen, R. E. Slade and Wm. H. Albro. The corporation is hereafter to be known as the Citizens Gas and Electric Light Company, and it is capitalized in \$100,000.

THE City Council of Annapolis, Md., has adopted an order granting the right to the Annapolis Electric Light Company to lay gas mains through "the streets, lanes and alleys of Annapolis, for illuminating and other purposes, provided the same be laid so as not to obstruct the proper use of the streets," etc.

A DRAUGHT of the plans for the proposed new Smith avenue plant for the Troy (N. Y.) Gas Company has been completed.

WE understand that operations have been resumed on the plant of the Empire Gas and Electric Light Company, of Huntington, L. I., which work was temporarily suspended on account of certain financial difficulties in which its President (Mr. Claassen) became involved.

THE North Attleboro (Mass.) Gas Company wants to perform the public lighting of that town by means of Gordon lamps.

AT the session of the Rhode Island Senate, held April 18, Senator Pond called up the special order granting the Electric Power and Machine Company power to lay gas pipes in the city of Woonsocket. Senator Garvin asked for information in respect to the animus of the motion, and Senator Andrews said it was simply a local affair. He incidentally remarked that the "Woonsocket Gas Company was accidentally given the power to put in electric light last year, consequently it was only fair that the electric light company should be put in position to compete." To this Senator Garvin made the somewhat common-sense reply, "that it was a very different matter from competition between two gas companies. Because a mistake was made last year there was no reason for carrying it further." Continuing, he said: "There appeared to be only two objects for asking for these powers—either to allow the two companies to consolidate, or to have competition. If the first was carried and the Legislature passed this bill, it would become a party to the watering of stock, and thus help to increase the cost of gas to the citizens of Woonsocket. There was no argument in favor of having two companies, so far as the price of gas is concerned. In Fall River, Mass., the price of gas is \$1.57, while the average cost in cities of that State having but one gas company was \$1.49. Rhode Island should have a Gas Commission similar to that in Massachusetts, but in the absence of a Commission the State should adopt a positive policy in respect to the supply of gas and electricity, and that policy should be not to allow the placing of two gas companies in one city. The only argument in this Woonsocket case was that no one so far objected to the grant, and that the City Council favored it. The Legislature, however, did not know what the City Council might do; it was like giving a razor to a baby." Senator Pond sarcastically alluded to the last speaker by comparing him to the Spanish hero who went around fighting windmills. He went over the history of the two cases again. It was only the question of putting one company on the same footing as the other. There was nothing hidden in it, and if granted the City Council would treat it in a business way. There was scarcely a city of any importance on the face of the earth that did not have more than one gas company. Senator Garvin suggested that his colleague, Pond, would have been closer to Senatorial dignity had he, instead of indulging in personalities, attempted to show what benefit the people of Woonsocket would gain in the passage of this act. When the debate terminated a motion to adopt the act was agreed to by a vote of 15 to 6.

WE are indebted to a correspondent (who writes under date of 16th inst.) for the following interesting particulars regarding the artificial lighting supply of Helena, Montana:

"Yesterday the preliminaries were arranged for the consolidation of two of Helena's largest lighting plants, involving over \$250,000. The Helena Gas Light and Coke Company (C. W. Cannon, President) and

the Helena Steam Power and Lighting Company (H. M. Parchen, President) will be merged into one Company. At a meeting held yesterday the terms were agreed upon, and the perfection of the organization is soon to follow. The building now occupied by the Helena Steam Power and Lighting Company is to be vacated and the machinery removed to a new building 50 x 75 feet, to be built at once near the gas works. One of the stockholders of the new Company stated that it was the intention to expend about \$150,000 in improvements in enlarging the gas works and purchasing additional machinery, which will make the plant the finest in the West. The present works of the consolidated Company, together with the improvements agreed upon, will give the plant when completed and improved a cash valuation of over \$500,000. One important move will be the extension of gas mains to many of the rapidly filling suburbs. The consolidation makes a Company to which the costs of improvements are not a strain. The men interested have ample funds to further any enterprise in the way of spreading light which they may undertake. In the directory will probably be found some of Helena's most prominent names."

The Council Bluffs Gas and Electric Light Company has concluded to branch out, and will enlarge its works and better fit itself for the production of gas, in spite of the fact that the consumption of that article in the city does not run on the average above 30,000 feet per day. The coal gas plant will certainly be improved by the addition of a new boiler and other fixtures, and it is probable that a plant for the manufacture of water gas will be put in. This plan has been under consideration for a long time past, but has been regarded as something which could possibly be acquired now. But the members of the Company, after consulting together, have almost reached the conclusion that it will be a good thing in the long run to put the water gas plant in now, and it is probable that the contracts for the erection of the necessary buildings will be let within a few weeks; and when this has been done the work will be pushed as rapidly as possible. The new plant will cost, if erected, from \$25,000 to \$30,000.

MR. JOHN P. HARBISON, acting for the Hartford (Conn.) City Gas Company, has entered into a contract with the United Gas Improvement Company, under which the latter will install on the Hartford works a water and fuel gas plant, to have a capacity of 500,000 cubic feet. The plant will be completed in about three months.

The Cheapest Light.

At the session of the National Academy of Sciences, held in Washington, April 17, Professor Langley read a paper "On the Cheapest Light." In all artificial lights, he said, there is an enormous waste of energy. Thus, in heating a poker to incandescence at least 15-16ths of the amount of coal burned is required to raise the temperature sufficiently to emit light. It is as if we had to strike all the low notes of a piano before we could sound an upper one. If, while using such an instrument, we should hear the singing of a bird, we should realize that Nature had provided a far simpler apparatus.

We find an analogous case in the simplicity and economy of natural compared with artificial methods of producing light. The paper gives an account of observations on a firefly (*Pyrophorus noctilucus*), many specimens of which were secured from the West Indies, and the spectrum of light emitted by them was studied with the aid of the spectroscope, while the heat emitted was measured by Langley's bolometer.

The spectrum from light from this insect is very short, extending only from F to C, and culminating in green, so that the heat rays are entirely absent, not heat enough being emitted to raise the temperature of the bolometer 1-200,000 of a degree Centigrade in 10 seconds' exposure.

That the absence of heat rays is not caused by the faintness of the light is shown by comparing it with light from a candle reduced to the same amount, which is accompanied by two or three hundred times as much heat.

In all ordinary methods of illumination there is a loss of at least one hundred, probably several hundred times as much heat as is utilized, most of the energy being consumed in raising the temperature of flame to at least two thousand degrees.

The light of the firefly is not a vital, but a chemical process, in other words, combustion, as is proved by the fact that nitrogen quenches and oxygen enhances it, and that it is attended by the production of carbon dioxide; though, as respects heat, it is even more economical than sunlight. It seems that chemistry should find means to imitate this process, giving us a form of combustion wherein the energy of fuel is all converted into light instead of being mostly wasted in heat.



A. M. CALLENDER & CO.,
PROPRIETORS.

EDITOR—**Jos. R. Thomas, C.E.**
ASST. EDITOR—**T. J. Cunningham.**
MANAGER—**C. E. Sanderson.**

PUBLISHED ON EACH MONDAY OF THE YEAR AT
No. 42 Pine Street, New York.

This is a recognized official organ of
LIGHT, HEAT, STEAM, WATER SUPPLY,
VENTILATION, SANITARY IMPROVEMENT,
AND GENERAL SCIENCE

TERMS:

SUBSCRIPTION—Three Dollars per annum, in advance. Single copies, 10 cents.

AGENTS.

NEW YORK.—AMERICAN NEWS Co., 39 and 41 Chambers Street.
PHILADELPHIA.—PRATT & CO., Corner Ninth and Arch Streets.
Germany.—B. WESTERMANN & CO., of New York.

MONDAY, APRIL 28, 1890.

Gas Stocks.

Quotations by **Geo. W. Close, Broker and Dealer in Gas Stocks,**
16 WALL ST., NEW YORK CITY.

APRIL 28.

All communications will receive particular attention.
The following quotations are based on the par value of \$100 per share.

	Capital.	Par.	Bid	Asked
Consolidated.....	\$35,430,000	100	98 ³ / ₄	—
Central.....	500,000	50	85	95
“ Scrip.....	220,000	—	95	100
Equitable.....	4,000,000	100	117	119
“ Bonds.....	1,000,000	—	113	115
Harlem, Bonds.....	170,000	—	—	—
Metropolitan, Bonds....	658,000	—	115	120
Mutual.....	3,500,000	100	109	112
“ Bonds.....	1,500,000	—	100	102
Municipal, Bonds.....	750,000	—	—	—
Northern.....	—	50	—	—
“ Bonds.....	150,000	—	—	100
Standard Gas Co--				
Common Stock.....	5,000,000	100	—	45
Preferred.....	5,000,000	100	84	87
Yonkers.....	—	50	112	—
Richmond Co., S. I....	346,000	50	—	—
“ Bonds.....	20,000	—	—	—
Gas Co's of Brooklyn.				
Brooklyn.....	2,000,000	25	115	120
Citizens.....	1,200,000	20	68	70
“ S. F. Bonds..	320,000	1000	100	103
Fulton Municipal.....	3,000,000	100	125	130
“ Bonds....	300,000	—	100	105
Peoples.....	1,000,000	10	84	88
“ Bonds (5's).....	368,000	—	100	—
“ “ (6's).....	94,000	—	100	—
Metropolitan.....	1,000,000	100	100	104
Nassau.....	1,000,000	25	120	—
“ Cfs.....	700,000	1000	100	102
Williamsburgh.....	1,000,000	50	123	125
“ Bonds... ..	1,000,000	—	110	112

Out of Town Gas Companies.

Boston United Gas Co. —				
1st Series S. F. Trust	7,000,000	1000	93	93 ¹ / ₂
2d “ “ “	3,000,000	1000	71	72
Bay State Gas Co.—				
Stock.....	5,000,000	50	23 ¹ / ₂	25
Income Bonds.....	2,000,000	1000	—	—
Buffalo Mutual, N. Y...	750,000	100	90	95
“ Bonds... ..	200,000	1000	95	100
Citizens, Newark.....	1,000,000	50	155	160
“ “ Bonds.	45,000	—	—	—
Chicago Gas Trust.....	25,000,000	100	48 ⁷ / ₈	—
Chicago Gas Light & Coke Co.—				
G'd Gold Bonds	7,650,000	1000	95 ³ / ₄	—
Equitable Gas & Fuel Co., Chicago, Bonds	2,000,000	1000	94 ⁷ / ₈	95 ¹ / ₂
People's Gas and Coke Co., Chicago—				
1st Mortgage.....	2,100,000	1000	—	100
2d “	2,500,000	1000	96	100
Consumers Gas Light Co., Jersey City.....	2,000,000	100	20	—
Bonds.....	600,000	1000	80	—
Cincinnati G. & C. Co..	6,000,000	100	201	203
Consumers Toronto....	1,000,000	50	190	200
Central, S. F., Cal.....	—	—	80	90
Capital, Sacramento, Cal	—	—	58	—
Consolidated, Balt.....	11,000,000	100	49 ¹ / ₂	50
“ Bonds.....	6,400,000	—	107	107 ¹ / ₂
Citizens Gas Lt. Co., Rochester, N. Y.....	500,000	—	75	90
Bonds.....	250,000	—	—	—
Hartford, Conn.....	750,000	25	102	108
Jersey City.....	750,000	20	170	175
Laclede Gas Light Co., St. Louis, Mo.—				
Common Stock....	7,500,000	100	10	16
Preferred “	2,500,000	100	—	—
Bonds.....	9,034,400	1000	82	—
Louisville, Ky.....	2,570,000	50	125	130
Little Falls, N. Y.....	50,000	100	—	100
“ Bonds	25,000	—	100	103
Montreal, Canada.....	2,000,000	100	200	208
Memphis (Tenn.) Gas... ..	750,000	100	40	—
“ Bonds.	240,000	100	103	—
New Haven, Conn.....	—	25	200	—
Oakland, Cal.....	—	—	35	35 ¹ / ₂
Peoples, Jersey City... ..	—	—	60	61
“ “ Bonds..	—	—	—	—
Paterson, N. J.....	—	—	25	99
Rochester, N. Y.....	—	—	50	99
Syracuse, N. Y.....	500,000	25	—	—
San Francisco Gas Co.				
San Francisco, Cal... ..	10,000,000	100	55 ¹ / ₂	55 ³ / ₄
Washington, D. C.....	2,000,000	20	200	208
Wilmington, Del.. ..	—	—	50	88

Advertisers Index.

	Page
GAS ENGINEERS.	
Jos. R. Thomas, New York City	609
Wm. Henry White, New York City.....	615
Wm. Mooney, New York City.....	609
William Gardner, Pittsburgh, Pa.....	609
Fred. Bredel, N. Y. City.....	611
GAS WORKS APPARATUS AND CONSTRUCTION.	
James R. Floyd & Sons, New York City	615
Continental Iron Works, Greenpoint, L. I.....	615
Delly & Fowler, Phila., Pa.....	615
Kerr Murray Mfg. Co., Fort Wayne, Ind.....	612
Stacey Mfg. Co., Cincinnati, Ohio.....	615
Bartlett, Hayward & Co., Baltimore, Md.....	613
Morris, Tasker & Co., Limited, Phila., Pa.....	613
Davis & Farnum Mfg Co., Waltham, Mass.....	612
R. D. Wood & Co., Phila., Pa.....	614
Bouton Foundry Co., Chicago, Ills.....	615
Smith & Sayre Manufacturing Co., New York City.....	614
Fred. Bredel, N. Y. City.....	611
United Gas Improvement Co., Phila., Pa.....	605
National Gas Light and Fuel Co., Chicago, Ills.....	602
Simpkin & Hillyer, Richmond, Va.	599

GAS AND WATER PIPES.	
Gloucester Iron Works, Phila., Pa.....	609
Mellert Foundry and Machine Co., Reading, Pa. (John Fox, Selling Agent, N. Y.).....	609
Ohio Pipe Co., Columbus, Ohio.....	609
M. J. Drummond, New York City.....	609
R. D. Wood & Co., Phila., Pa.....	614
Warren Foundry & Machine Co., New York City.....	609
Donaldson Iron Co., Emaus, Pa.....	609
Dennis Long & Company, Louisville, Ky.....	609
PROCESSES.	
National Gas Light and Fuel Co., Chicago, Ills.....	602
Bartlett, Hayward & Co., Baltimore, Md.....	613
Wm. Henry White, N. Y. City.....	615
United Gas Improvement Co., Phila., Pa.....	605
The Fuel Gas and Light Improvement Co., N. Y. City.....	600
INCLINED RETORTS.	
Laclede Fire Brick Manuf'g Co., St. Louis, Mo.....	564
GASHOLDER TANKS.	
W. C. Whyte, New York City.....	602
J. P. Whittler, Brooklyn, N. Y.....	607
GASHOLDER PAINT.	
The Government Waterproof Paint Co., Boston, Mass.....	600
RETORTS AND FIREBRICK.	
J. H. Gautler & Co., Jersey City, N. J.....	610
B. Kreischer & Sons, New York City.....	610
Adam Weber, New York City.....	610
Laclede Fire Brick Manuf'g Co., St. Louis, Mo.....	610
Brooklyn Retort and Fire Brick Works, Brooklyn, N. Y.....	610
Borgner & O'Brien, Phila., Pa.....	610
James Gardner, Jr., Pittsburgh, Pa.....	610
Henry Maurer & Son, New York City.....	611
Chicago Retort and Fire Brick Co., Chicago, Ills.....	610
Baltimore Retort and Fire Brick Co., Baltimore.....	610
Oakhill Gas Retort and Fire Brick Co., St. Louis, Mo.....	610
Boston Fire Brick Works, Boston, Mass.....	610
SCRUBBERS AND CONDENSERS.	
G. Shepard Page, New York City.....	568
R. D. Wood & Co., Phila., Pa.....	614
REGENERATIVE FURNACES.	
Bartlett, Hayward & Co., Baltimore, Md.....	613
Fred. Bredel, New York City.....	611
Chicago Retort and Firebrick Co., Chicago, Ills.....	610
Wm. Henry White, N. Y. City.....	615
J. H. Gautler & Co., Jersey City, N. J.....	611
GAS GOVERNORS.	
Connelly & Co., New York City.....	607
Fred. Bredel, N. Y. City.....	611
Friedrich Lux, London, England.....	599
SELF-SEALING MOUTHPIECE DOORS.	
Smith & Sayre Mfg. Co., New York City.....	614
TAR AND CARBONIC ACID EXTRACTOR.	
Geo. Shepard Page, N. Y. City.....	604
CEMENTS.	
C. L. Gerould & Co., Brooklyn, N. Y.....	610
GAS ENRICHERS.	
Standard Oil Co., Cleveland, Ohio.....	616
GAS METERS.	
John J. Griffin & Co., Phila., Pa.....	618
American Meter Co., New York and Philadelphia.....	619
The Goodwin Gas Stove and Meter Co., Philadelphia, Pa.....	619
Heime & McIlhenny, Phila., Pa.....	619
D. McDonald & Co. Albany, N. Y.....	619
Nathaniel Tufts, Boston, Mass.....	618
Maryland Meter and Manufacturing Co., Baltimore, Md.....	600
Bell & Jones, Philadelphia, Pa.....	618
Harris Bros. & Co., Philadelphia, Pa.....	618
EXHAUSTERS.	
The P. H. & F. M. Roots Co., Connersville, Ind.....	606
Smith & Sayre Manufacturing Co., New York City.....	614
Willbraham Bros., Philadelphia, Pa.....	607
Connelly & Co., New York City.....	607
GAS COALS.	
Penn Gas Coal Co., Phila., Pa.....	617
Perkins & Co., New York City.....	616
Newburgh Orrel Coal Co., Baltimore Md.....	617
Despard Coal Co., Baltimore, Md.....	617
Chesapeake and Ohio R. R. Coal Agency, N. Y. City.....	617
Westmoreland Coal Company, Phila., Pa.....	617
J. & W. Wood, New York City.....	616
CANNEL COALS.	
Perkins & Co., New York City.....	616
J. & W. Wood, New York City.....	616
VALVES.	
Ludlow Valve Manufacturing Co., Troy, N. Y.....	608
John McLean, New York City.....	608
Chapman Valve Manufacturing Co., Boston, Mass.....	608
R. D. Wood & Co., Phila., Pa.....	614
The P. H. & F. M. Roots Co., Connersville, Ind.....	606

GAS ENGINES.

Schleicher, Schumm & Co., Phila., Pa. 584
 Clerk Gas Engine Co., Phila., Pa. 608
 Van Duzen Gas Engine Co., Cincinnati, Ohio. 608

ENGINES AND BOILERS.

Jarvis Engineering Co., Boston, Mass. 607
 Ball Engine Co., Erie, Pa. 600
 Westinghouse Machine Co., Pittsburgh, Pa. 611

STEAM PUMPS.

Van Duzen & Tift, Cincinnati, Ohio. 599

GAS LAMPS.

G. Shepard Page, New York City. 608
 Welsbach Incandescent Gas Light Co., Phila., Pa. 601
 The Siemens-Lungren Company, Philadelphia, Pa. 601
 Fiske, Coleman & Company, Boston, Mass. 610

PURIFIER SCREENS.

John Cahot, New York City. 608
 Bartlett, Hayward & Co., Baltimore, Md. 608

GAS STOVES.

American Meter Co., New York and Philadelphia. 603
 The Goodwin Gas Stove and Meter Co., Phila. Pa. 620
 George M. Clark & Company, Chicago, Ills. 601
 D. McDonald & Co., Albany, N. Y. 619
 Maryland Meter and Manufacturing Co., Baltimore, Md. 600
 Bell & Jones, Philadelphia, Pa. 618
 Chicago Gas Stove Company, Chicago, Ills. 600

STREET LAMPS.

J. G. Miner, Morrisania, New York City. 563
 Bartlett Street Lamp Man'g Co., New York City. 599

BURNERS.

C. A. Gefroerer, Phila., Pa. 616
 H. W. Rappleye, Philadelphia, Pa. 368

STEAM BLOWER FOR BURNING BREASE.

H. E. Parson, New York City. 572

PURIFYING MATERIAL.

Connelly & Co., New York City. 607
 Friedrich Lux, London, England. 599
 Edgewater Lime Works, Edgewater, N. J. 599

COKE CRUSHER.

C. M. Keller, Columbus, Ind. 617

ELECTRICAL APPARATUS.

Wm. Henry White, N. Y. City. 615

BOOKS, ETC.

Gerould's System Gas Bookkeeping. 600
 1889. Directory. 607
 King's Treatise. 609
 Scientific Books. 350
 Management of Small Gas Works. 608
 Gas vs. Electricity. 600
 Practical Electric Lighting. 607
 Electric Light Primer. 607
 American Gas Engineer and Superintendents' Handbook. 617
 Digest of Gas Law. 599
 Fuel and its Applications. 599
 Newhigging's Handbook. 611

Position Wanted

As Superintendent of Gas Works, or Gas, Electric Light, or Water Works.

Have been Superintendent of gas works for the past 17 years. Formerly acted as Superintendent of water works. Can give the best of references. DAN'L DOUGHERTY, Late Supt. Jeffersonville Gas Co., Jeffersonville, Ind. 777-2

WANTED,

By a New England Gas Company,

A Man to Repair Meters, take Meter Readings, etc.

776-5 Address "H. R.," care this Journal.

Position Wanted

As Superintendent of Works.

Elther Coal or Water Gas.

Address "B. W.,"

774-4 Care this Journal.

**FOR SALE,
 One Eight-Inch Steam Jet
 Exhauster.**

Kerr Murray make, and one of the best. Address
 J. B. HOWARD, Supt. Key City Gas Co.,
 776-tf Duhuque, Iowa.

FOR SALE,

The Ironwork for 11 Benches of 5's, viz.:
Cast Iron Hydraulic Mains, 17 inch diameter, inside.
Dip Pipes, Bridge Pipes, Stand Pipes.
Mouthpieces and Lids.
Four Purifiers, 10 by 16 ft., with 10-inch Connections and dry Center Seal.
Four Purifiers, 5½ by 10 ft., with 6-inch Connections and Wet Center Seal.
Valves, 6-inch, 8-inch, and 10-inch.

DAVID MOORE, Treas. Salem Gas Lt. Co.,
 770-tf Salem, Mass.

FOR SALE,

The Ironwork for Twelve Benches of 6's, viz.:
Cast Iron Hydraulic Main.
7-inch Dip-Pipes, Stand-Pipes, and Bridge-Pipes, complete.
Floyd Mouthpieces and Self-Sealing Lids, 15x26 in.
 Lids and Mouthpieces only in use over a year. Will be sold cheap.
 ISAAC C. BAXTER,
 772-tf Detroit (Mich.) Gas Lt. Co.

FOR SALE.

A Complete Water Gas Plant.
60,000 Cu. Ft. Daily Capacity.

Fully equipped; all the latest improvements; includes Generator, Purifiers, and Holder. Can be removed to any part of the country, and set up at small cost. For further information apply to BRADFORD GAS LT. & HEATING CO., Dunkirk, N. Y.

Fuel and Its Applications.

By E. J. MILLS, D.Sc. F.R.S., and F. J. ROWAN, C.E., assisted by others, including Mr. F. P. Dewey, of the Smithsonian Inst., Wash., D. C.

7 PLATES, AND 607 OTHER ILLUSTRATIONS. ROYAL OCTAVO, PAGES xx, 802. HANDSOME CLOTH, \$7.50.

A. M. CALLENDER & CO., 42 Pine St., N. Y.

Simpkin & Hillyer

RICHMOND, VA.

MANUFACTURERS OF

Gas Works Apparatus

BENCH CASTINGS, CONDENSERS,
Scrubbers, Purifiers, Dry Center Seals,
FOUR-WAY VALVES, GAS VALVES,
SULPHATE OF AMMONIA APPARATUS,
TANKS, ENGINES, BOILERS,
PUMPS, ETC., ETC.

Plans, Specifications and Estimates furnished for new works, or alteration of old works. Correspondence solicited. Works, Newport News, Va.

Bartlett Street Lamp Mfg. Co.

MANUFACTURERS OF

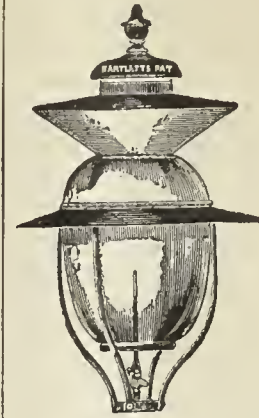

Globe Lamps,

FOR

Streets, Parks, Public Buildings, Railroad Stations, etc.

LAMP POSTS

A Specialty.

Office and Salesroom,

40 & 42 COLLEGE PLACE, - - N. Y. CITY.

Gas Companies and others intending to erect Lamps and Posts will do well to communicate with us.

**VAN DUZEN'S
 STEAM JET PUMP**

For MILLS, FACTORIES, SHOPS, ETC.
 For Elevating and Conveying Liquids.
 For Emptying Pits, Sinks, Cesspools, etc., and as a Fire Pump.
 10 Sizes. \$7 to \$75. Every Pump warranted.
 Write for Descriptive Book to VAN DUZEN & TIFT, 106 E. Second St., CINCINNATI, O.

FRIEDRICH LUX,

Ludwigshafen am Rhein and London.

**Lux Mass,
 GAS GOVERNORS,
 Gas Balance.**

EDGEWATER LIME WORKS

Chas. F. McKenna, Proprietor.

SHELL LIME.

Lime by the Cargo for Gas Purification.

EDGEWATER, BERGEN CO., N. J.

Write for Testimonials and Prices.

**GREENOUGH'S
 "DIGEST OF GAS LAW."**

Price, \$5.00.

This is a valuable and important work, a copy of which should be in the possession of every gas company in the country, whether large or small. As a book of reference it will be found invaluable. It is the only work of the kind which has ever been published in this country, and is most complete. Handsomely bound. Orders may be sent to

A. M. CALLENDER & CO.,

42 Pine Street, N. Y.

F. D. HARMON, Pres.

CHAS. C. ALLEN, Sec. and Treas.

P. W. MACKENZIE, Chief Engr.

THE FUEL GAS AND LIGHT IMPROVEMENT CO.

OF AMERICA.

Owner of the Mackenzie Patents of Dec. 31, 1889, and later dates.

For the United States, England, Russia, France, Germany, Austria, and Canada,

No. 32 Park Place, New York City.

This SYSTEM is an ABSOLUTELY NEW DEPARTURE IN THE MANUFACTURE OF FUEL AND ILLUMINATING GAS. The COST OF GAS IN THE HOLDER by our System is at least THIRTY PER CENT. LESS than that made by any other process of the day. The Gas contains neither SULPHUR nor other impurities, nor is there any resultant LAMPBLACK OR TAR RESIDUUM. The Gas is manufactured WHOLLY from LIQUID HYDROCARBONS, such as Lima, Penn. Crude, and Fuel Oils, Naphtha, etc. Neither PERISHABLE PIPES nor other RETORTS, NOR THEIR EQUIVALENTS, are used. Neither COAL, COKE, nor any other HARD CARBONS enter into the manufacture or composition of the Gas, thereby requiring LESS LABOR THAN ANY OTHER METHOD. The APPARATUS is extremely SIMPLE, SUBSTANTIAL, and DURABLE. Works under our system may be CONTINUOUS or ALTERNATING. If alternating, the Nitrogen present will be less than 4½ per cent. If continuous, the limited amount of Nitrogen present is neutralized by Carbon. One gallon of Lima oil by our process EQUALS ALL THE COAL required for making 1,000 feet of carbureted Water Gas.

CHARLES E. DICKEY.

JAMES B. SMALLWOOD.

CHARLES H. DICKEY.

THE MARYLAND METER AND MANUFACTURING CO.

Established 1866.

BALTIMORE, North & Saratoga Sts.

CHICAGO, 197 Michigan Street.

NEW YORK, 766 Broadway.

BOSTON, 4 Central Street.

ST. LOUIS, 1115 Olive Street.

SAN FRANCISCO, 330 Pine Street.

CONSUMERS' & STATION METERS, PRESSURE GAUGES, Etc., Etc.

"Success" and "Perfect" Gas Stoves.

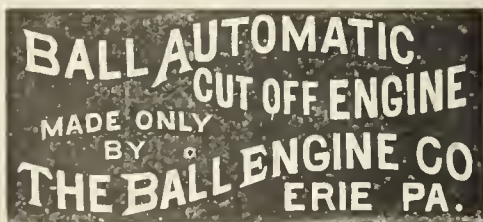

GASHOLDER PAINT.

Use Only

THE GOVERNMENT WATERPROOF PAINT.

Proof against Ammonia, and Absolutely Waterproof. Send for Prices and Particulars.

THE GOVERNMENT WATERPROOF PAINT CO., 122 Milk Street, Boston, Mass.

GEROULD'S System Gas Bookkeeping.

Approved and adopted by many of the prominent Gas Engineers of the Country.

Sample Sheets and Price-List furnished free on application to

L. P. GEROULD, - - Mendota, Ill.

GAS vs. ELECTRIC LIGHT.

We would invite attention to the able and exhaustive argument of General A. Hickenlooper, President of the Cincinnati Gas Light and Coke Company, contained in a handsome pamphlet of 96 pages, entitled

"EDISON'S INCANDESCENT ELECTRIC LIGHTS FOR STREET ILLUMINATION. REPORT OF AN ARGUMENT DELIVERED BY A. HICKENLOOPER BEFORE THE COMMITTEE ON LIGHT, MUNICIPAL COUNCIL, CITY OF CINCINNATI, JULY 22, 1886."

This is a subject of special interest to all Gas Light Companies.

Prices.

25 copies.....	\$7.50	100 copies.....	\$22.50
50 copies.....	12.50	250 copies.....	50.00

A sample copy will be sent by mail on receipt of 50 cts

A. M. CALLENDER, & CO., 42 PINE ST., N. Y. CITY

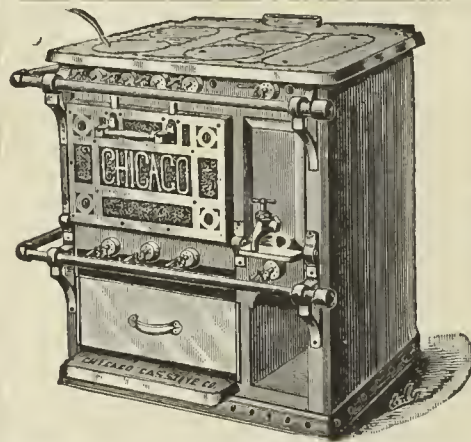

CHICAGO GAS STOVE CO.

MANUFACTURERS OF ALL KINDS OF

Gas Cooking and Heating APPLIANCES.

117-119 Lake St., CHICAGO.

Send for Catalogue.

PATENTS.

FRANKLIN H. HOUGH

Solicitor of American & Foreign Patents.

925 F. ST., WASHINGTON, D. C.

(NEAR U. S. PATENT OFFICE.)

Personal attention given to the preparation and prosecution of applications for Letters Patent. All business before the U. S. Patent Office attended to for moderate fees. **No Agency in the United States possesses superior facilities for obtaining Patents,** or for ascertaining the patentability of inventions. Copies of patents furnished for 25 cents each. Correspondence solicited.

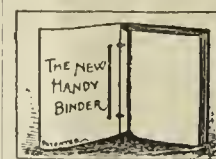

THE NEW HANDY BINDER.

This article may be described as elegant in appearance, strong, durable, and possessing many special qualities of its own. It allows the opening of the pages perfectly flat, whether one or several numbers are in the binder. Any number can be taken out and replaced without disturbing the others. The papers are not mutilated for subsequent binding in permanent form. The binder is supplied with gilt side title, and is an ornament to any desk or reading table. The JOURNAL, filed in the Handy Binder, becomes a volume of great value, always convenient for instant reference. **Handy Binder, Postage paid, \$1.00.**

A. M. CALLENDER & CO., 42 Pine St., N. Y.

The Gordon Portico Lamp.

A successful Competitor of the Arc Electric Light for lighting Store Fronts, Show Windows, Depots, Railway Sheds, etc., etc.

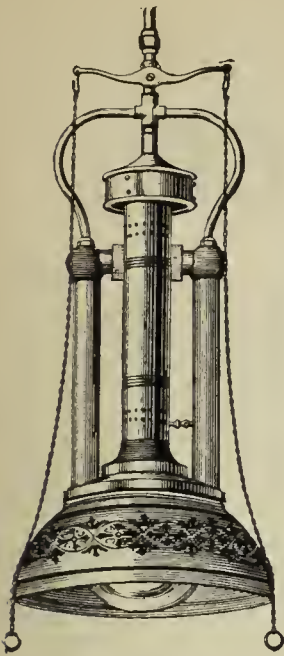

Gordon Portico Lamp.

The Gordon Street Lamp.

A Successful Competitor of the Arc Electric Light for lighting Streets, etc., etc.

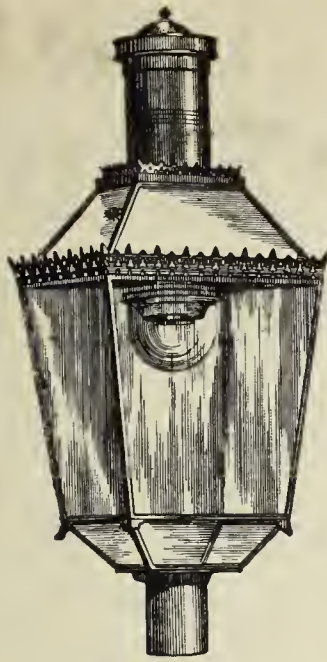

Gordon Street Lamp.

The Lungren Lamp.

A Successful Competitor of the Incandescent Electric Light for Interiors, etc. Is especially applicable for the lighting of Offices, Stores, Factories, Mills, Show Windows, Libraries, and all situations where an increased illumination is desired.

More than 25,000 Lungren Lamps are now in use. Testimonials, references, or any desired information will be cheerfully given.

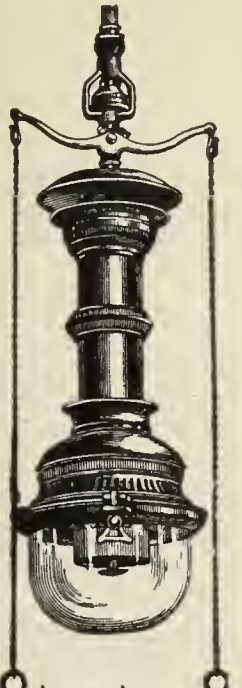

Lungren Lamp.

THE SIEMENS-LUNGREN CO., N.E. Cor. 21st St. & Washington Av., PHILADELPHIA.

WELSBACH SYSTEM OF Incandescent Gas Lighting.

OFFICE, DREXEL BUILDING, PHILA., PA.

At the Fall Session of the Board of Supervisors of Winnebago County, held at the County Court House, Oshkosh, Wis., Nov. 26, 1889, the report submitted by Mr. C. W. Cook, Chairman of the Committee on Public Buildings, recommending the use of the Welsbach Incandescent Gas Burner in the Buildings under their charge, was unanimously adopted, because of the extreme economy in the consumption of Gas and the superior character of the light obtained.

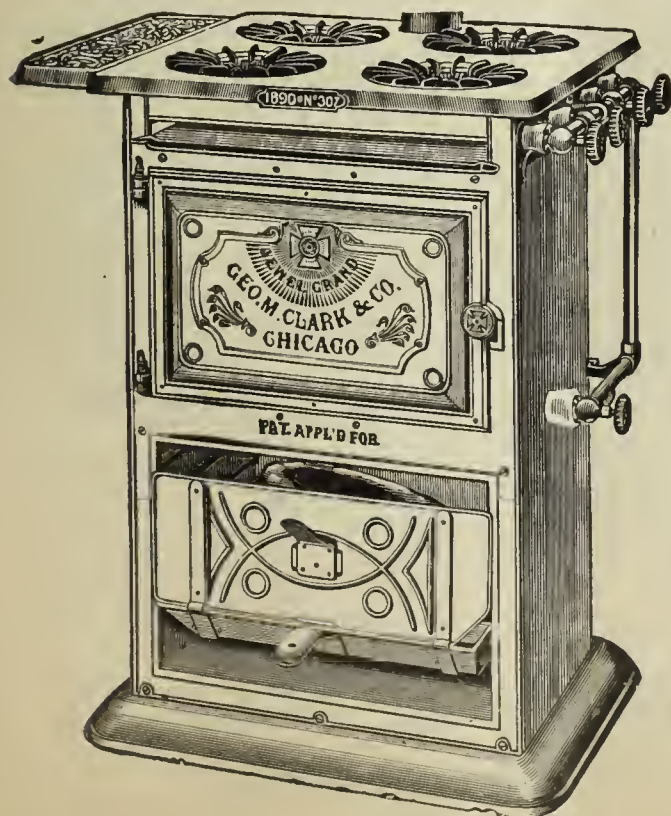

JEWEL GAS STOVES

MANUFACTURED BY

GEORGE M. CLARK & COMPANY,

Nos. 157 & 159 Superior Street, - - - Chicago, Ill.

EVERY CONCEIVABLE SIZE AND STYLE,

Ranging in Prices from \$1.50 to \$30.00.

WE USE NO GAS COCKS.

All Flames are Regulated by a Direct Needle Valve.

The JEWEL

IS THE

Only Well-Made Gas Stove on the Market.



Write for our 1890 Catalogue and see for yourself.

NATIONAL GAS LIGHT AND FUEL CO.,

218 La Salle Street, Chicago.

C. D. HAUK, Prest. & Gen'l Manager.

A. W. GREEN, Vice-Prest.

N. A. McCLARY, Sec. & Treas.

E. E. MORRELL, Engr.

GAS WORKS

Built, Remodeled, Leased, and Purchased.

71 Springer Cupolas have been installed in the U. S. during the past four years.

The total capacity of Springer Apparatus now in use is over 25,000,000 ft. daily.

THE SPRINGER CUPOLA SYSTEM

Has Proven Itself the most Economical and Satisfactory Method of Gas Manufacture ever brought to the attention of the Gas Fraternity.

GUARANTEED ESTIMATES of Cost of Gas Furnished on Application.

GASHOLDER TANK CONSTRUCTION, ETC.

Gas Companies and others about to erect Gasholders will find it profitable to consult W. C. Whyte, who for over 30 years has made a specialty of

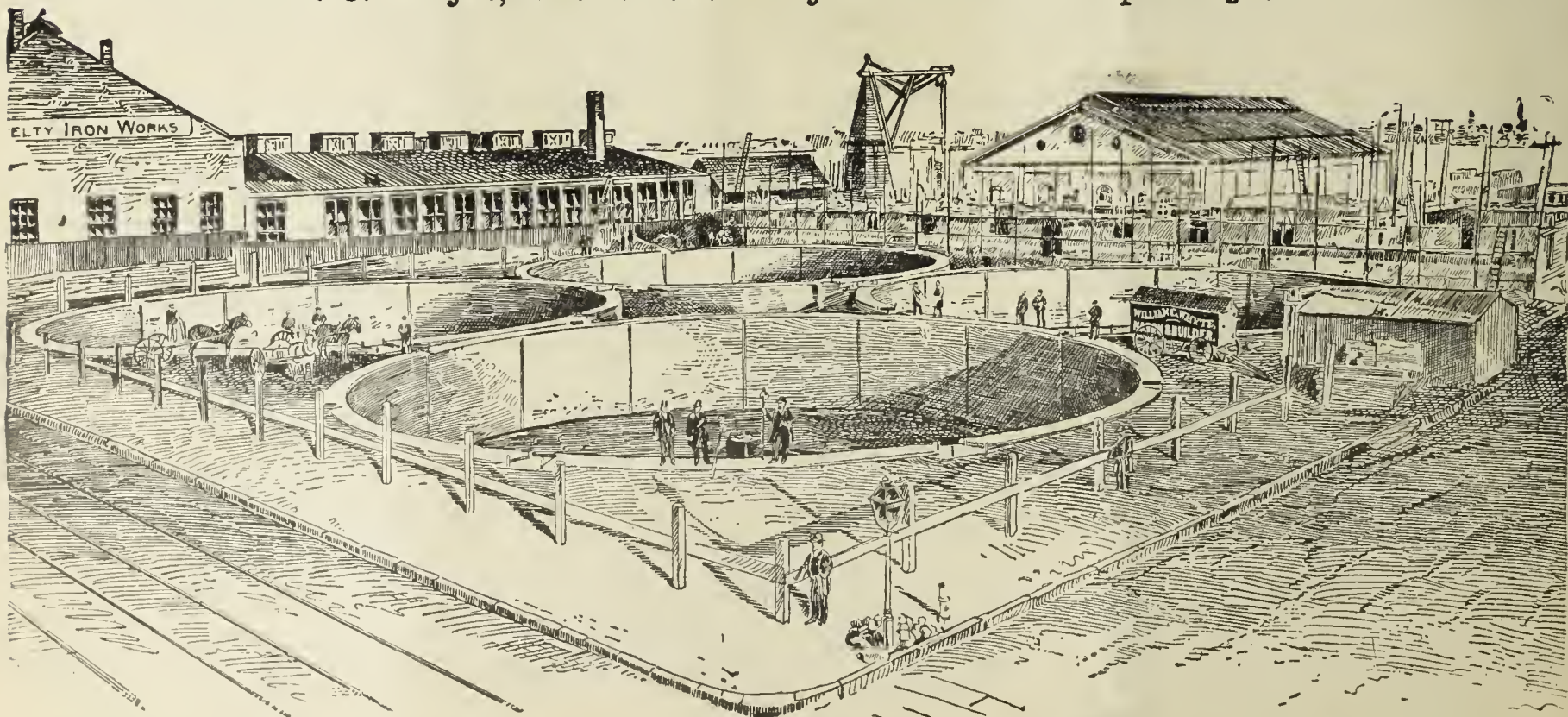

Tank Excavation and Mason Work.

Fifty Tanks now in operation show the sort of work done. Address

W. C. WHYTE, - No. 15 Cortlandt Street, N. Y. City

GAS STOVES.

GAS METERS.

GAS STOVES.

THE AMERICAN METER CO.,

MANUFACTURERS OF

GAS METERS, Station Meters,

METER PROVERS, PHOTOMETERS,

PRESSURE GAUGES OF ALL KINDS,



Standard 3 Diaphragm Dry Meter



Standard 2 Diaphragm Dry M r.

AND

Apparatus for Testing the Quantity and Quality of Gases.

GAS STOVES FOR HEATING AND COOKING

Sole Agents in the United States for

Verity's Patent Gas Fires.

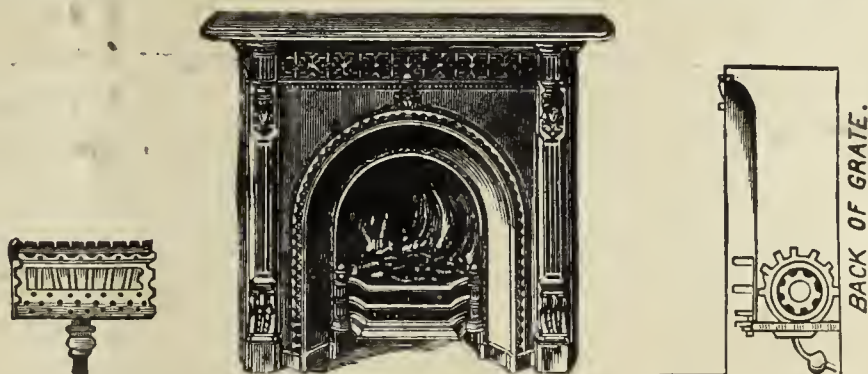

Circulars and Price Lists on Application.

MANUFACTORIES,

508 to 514 West Twenty-second St., N. Y.

Arch and Twenty-second St., Phila.

Nos. 244 & 246 North Wells Street, Chicago, Ill.

AGENCIES,

No. 177 Elm Street, Cincinnati, Ohio.

No. 222 Sutter Street, San Francisco, Cal.

No. 810 North Second Street, St. Louis, Mo.

GAS STOVE SHOW ROOMS, No 242 Sixth Avenue, New York City.

THE WALKER TAR AND CARBONIC ACID EXTRACTOR.

A very general demand exists, in both large and small Gas Works, for an apparatus that will be absolutely efficient in the removal of the tar which passes the hydraulic main and condenser. Many attempts have been made to accomplish this, but, I believe, without success, until the introduction, five years ago, in England, of the C. & W. Walker Patent Tar and Carbonic Acid Extractor. During these years this apparatus has been adopted by many of the most prominent Engineers, not only in England, but also on the Continent of Europe and in other parts of the world. It is only necessary to give here a partial list in order to convince any intelligent American Gas Engineer that this machine must have succeeded fully in accomplishing the desired results.

The following Engineers have personally given permission to refer to them:

G. C. Trewby, Esq., Engineer-in-Chief of the Gas Light and Coke Co., London. The manufacturing plant at Beckton is built in complete sections of 3,000,000 cubic feet capacity each. A Walker Tar Extractor has been fitted to each one of these sections. This was done after a long and thorough trial on one of its sections. The Tar Extractor has been supplied to other works of the Gas Light and Coke Co., including those of which John Methven, Engineer of the Gas Light and Coke Co. at the Nine Elms Station, is in charge. Also to G. E. Stevenson, Peterborough Gas Works; B. Green, Mitcham and Wimbledon Gas Works; W. H. Smith, Bedford Gas Works; F. Linging, Norwich Gas Works; J. T. Browning, Colchester Gas Works; S. B. Darwin, Portsmouth Gas Works; J. McCrae, Dundee Gas Works; W. J. Wells, Stamford Gas Works; J. M. Darwin, Longton Gas Works; J. Paterson, Warrington Gas Works; and J. Coulter, of the Dundalk Gas Works. All of the foregoing gas works are located in Great Britain.

Mr. Charles A. Gerdenier, Superintendent of the Bridgeport (Conn.) Gas Light Company, writes as follows, under date of Dec. 3, 1887:

"The C. & W. Walker Tar and Carbonic Acid Extractor has been in operation at these works for the past six weeks, and is an unqualified success. It removes every particle of Tar from the gas in once passing through the apparatus, and a large percentage of the Carbonic Acid. I also feel quite sure that it prevents the formation and deposit of Naphthaline, because since I started the Washer I have had no stoppages from this cause. These works have been seriously troubled with Tar for many years, and I have used several kinds of apparatus and every expedient which has come to my attention for dealing with the difficulty, but without success. The Walker apparatus occupies comparatively small space, is less expensive than other systems, and requires but little attention. I carry 2½-inch seal, and have an automatic tar delivery valve. This Tar Extractor is indispensable to gas makers."

I have taken the Agency for the United States for this apparatus, and am now prepared to make contracts to erect it on the premises of any Gas Company. It would be manufactured in the following sizes:

No. 1,	50,000 to	100,000	cu. ft. per 24 hrs.,	3	ft. square,	5	ft. deep.
No. 2,	" "	125,000	" " "	4	" " "	" "	" "
No. 3,	" "	250,000	" " "	5	" " "	" "	" "
No. 4,	" "	500,000	" " "	6	" " "	" "	" "
No. 5,	" "	750,000	" " "	7	" " "	" "	" "
No. 6,	" "	1,000,000	" " "	8	" " "	" "	" "
No. 7,	" "	1,250,000	" " "	9	" " "	" "	" "
No. 8,	" "	1,500,000	" " "	10	" " "	" "	" "
No. 9,	" "	2,000,000	" " "	12	" " "	" "	" "
No. 10,	" "	3,000,000	" " "	15	" " "	" "	" "

This Tar Extractor will perform its work with about one-fourth the usual back-pressure heretofore required. It is simple in construction, and can be supplied at a very reasonable price—less than any other ever before introduced. Satisfactory results will be guaranteed in every instance.

GEO. SHEPARD PAGE,

SOLE AGENT FOR THE UNITED STATES,

No. 69 Wall Street, - - - New York

THE UNITED GAS IMPROVEMENT CO.

Drexel Building,

CHESTNUT AND FIFTH STREETS,

PHILADELPHIA, PA.

OFFICERS:

WILLIAM W. GIBBS, President.

GEORGE PHILLER, Vice-President.

SAML T. BODINE, Gen'l Manager.

RANDAL MORGAN, Gen'l Counsel.

EDWARD C. LEE, Sec'y and Treas.

ALEX. C. HUMPHREYS, Gen'l Supt.

WALTON CLARK, Ass't Gen'l Supt.

H. H. EDGERTON, Chem. and Eng'r.

DIRECTORS:

GEORGE PHILLER,

THOMAS DOLAN,

HENRY C. GIBSON,

WM. T. CARTER,

WILLIAM G. WARDEN,

SAML T. BODINE.

BUILDERS, LESSEES AND PURCHASERS OF

✻ GAS WORKS. ✻

ROOTS' GAS AND BYE-PASS VALVES.

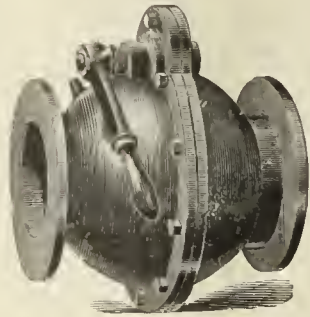

GAS VALVE

Quick Acting,
Simple,
Efficient, Durable.

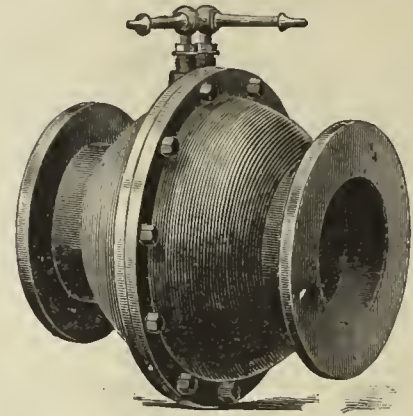

BYE-PASS VALVE.

Automatic Action
Reliable
Simple Durable.

Thousands now in use and giving perfect satisfaction. Write for Catalogue and Prices.

ROOTS' NEW GAS EXHAUSTER.

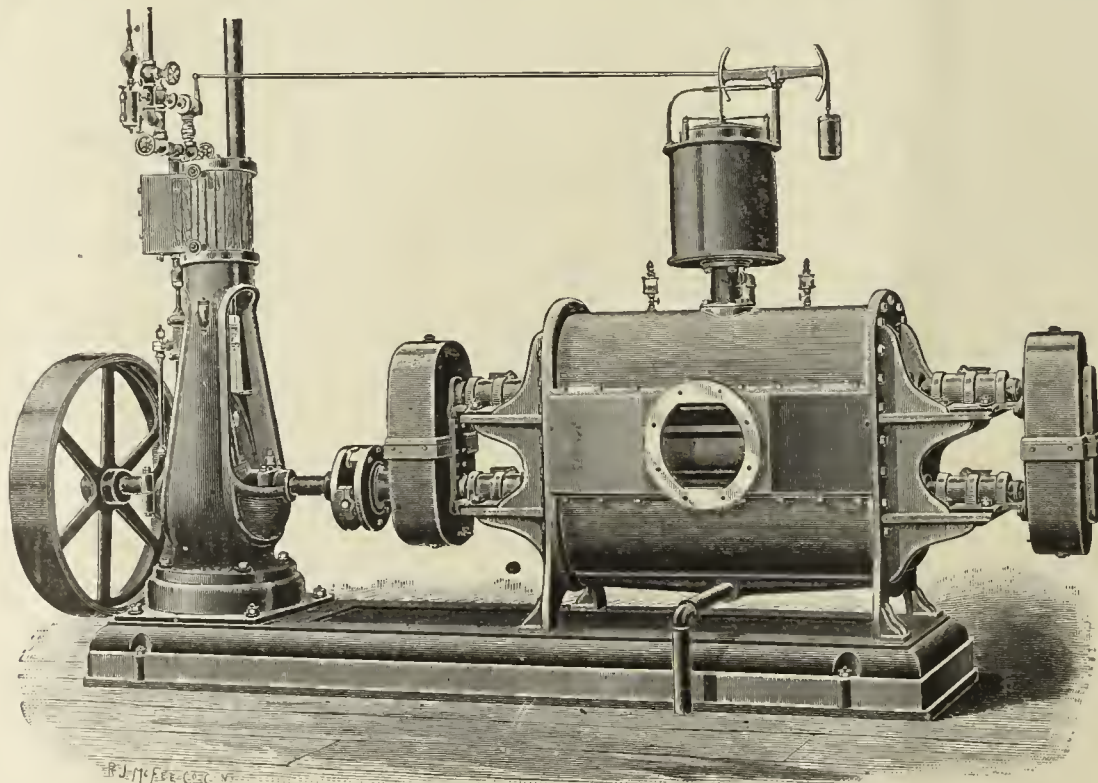

UNSURPASSED FOR

Neatness of Design, Durability, Simplicity, Efficiency, and Economy of Power.

THE ONLY EXHAUSTER MADE WHERE

The Parts Needing Attention are External, and Easily Accessible.

Send for Descriptive Catalogue and Price List.

THE P. H. & F. M. ROOTS CO., Patentees and Manufacturers, **CONNERSVILLE, IND.**

S. S. TOWNSEND, Gen. Agt., 22 Cortlandt St., N. Y.

COOKE & CO., Selling Agts., 22 Cortlandt St., N. Y.

CONNELLY & CO.,

SOLE MANUFACTURERS OF THEIR PATENTED SPECIALTIES.

"IRON SPONGE." Saves money, saves labor, and is the most efficient purifying agent ever offered as a substitute for lime. Now used in every State in the Union, and purifying daily over thirty-five million cubic feet. Should be used in every gas works. Its own saving will pay for it many times over.

AUTOMATIC GOVERNOR. Has been on the market but three years, and in that time has been introduced more generally than any invention ever designed for use in gas works. Over two hundred of them now in use. Sensitive; reliable; perfectly automatic; reduces leakage; satisfies consumers, and gives great relief to the Manager. No gas works is complete without one of these machines.

STEAM JET EXHAUSTER. Designed particularly for small works. Combines Exhaust Tube, Steam Governor Gas Compensator, and Bye-Pass Valves in the most compact form possible; occupies but little space; uses very little steam; operated by ordinary workmen; saves formation of carbon in retorts; increases yield 10 to 15 per cent. Specially adapted for mixing air with oil gas. No works too small to use them profitably.

Prices given on all our specialties delivered at any point in the United States. Correspondence solicited.

CONNELLY & CO., No. 111 Broadway, New York City.

WILBRAHAM GAS EXHAUSTER & ENGINE COMBINED.

WILBRAHAM BROS.,
PHILADELPHIA, PA.

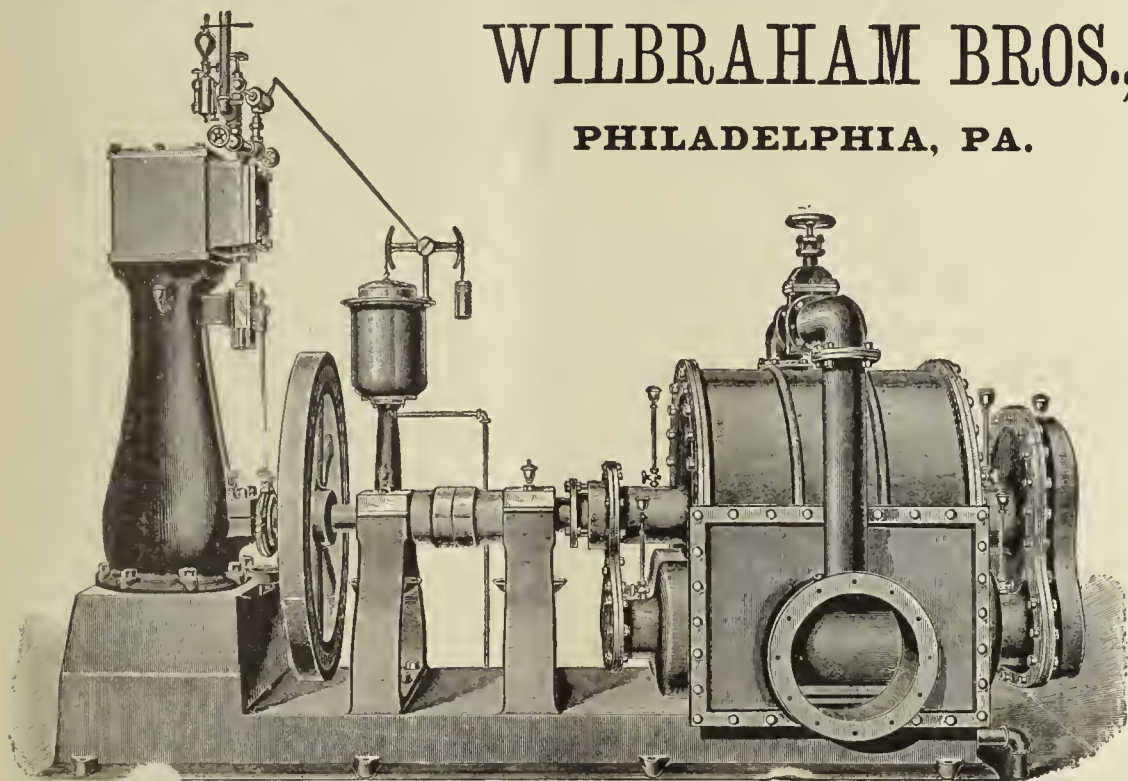

JARVIS ENGINEERING CO.,

61 Oliver St., Boston, Mass.

CONTRACTORS FOR ERECTING

COMPLETE STEAM OUTFITS FOR ELECTRIC LIGHTING STATIONS.

Steel Boilers set with Jarvis Pat. Boiler Setting

To burn **COKE SCREENINGS** for Fuel.

ARMINGTON & SIMS CO. ENGINES,

Belted direct to Dynamos, without using Shafting.

SEND FOR CIRCULARS.

REFERENCES.—Charlestown Gas & Electric Light Co., Charlestown, Mass.; Schenectady Gas & Electric Light Co., Schenectady N. Y.; Brookline Gas Co., Brookline, Mass.

Practical Electric Lighting

By A. BROMLEY HOLMES, A.M.I.C.E.

With 87 Illustrations. Third Edition. Price, \$1.00.

Electric Light Primer.

By CHARLES L. LEVEY.

A simple and comprehensive Digest of all the most important facts connected with the running of the Dynamo and Electric Lights, with Precautions for Safety, etc.

Price, 50 cents.

A. M. CALLENDER & CO., 42 Pine St., N. Y.

Gasholder Tanks & Gas Works Masonry Complete.

PLANS PREPARED AND ESTIMATES FURNISHED AT SHORT NOTICE.

J. P. WHITTIER, - - 499 Wythe Av., Brooklyn, N. Y.

1889 DIRECTORY 1889

OF THE GAS LIGHT COMPANIES of the UNITED STATES & CANADA.

Price, \$8.00.

A. M. CALLENDER & CO., No. 42 Pine Street, N. Y. City.



CHAPMAN VALVE MANUFACTURING CO.,

MANUFACTURERS OF

Valves and Gates for Gas, Ammonia, Water, Etc.

Also, Gate Fire Hydrants With and Without Independent Nozzle Valve. All Work Guaranteed.

WORKS & GEN'L OFFICE:
Indian Orchard, Mass.

TREASURER'S OFFICE:
72 Kilby & 112 Milk Sts, Boston, Mass.

LUDLOW VALVE MFG. CO.

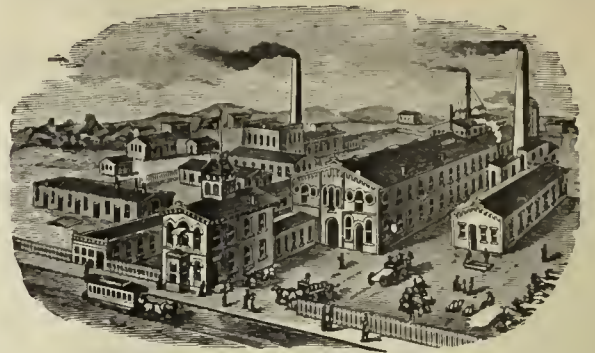

OFFICE AND WORKS,

938 to 954 River Street and 67 to 83 Vail Av.,
TROY, N. Y.

GEO. SHEPARD PAGE,

No. 69 Wall Street, N. Y. City.

REPRESENTING

THE BOWER GAS LAMP.

C. & W. Walker's Carbonic Acid & Tar Extracting Washer

B. DONKIN & CO.'S PAT. IMP. GAS VALVE.

Young & Beilby's Patents. Henry Aitkin's Patents.

R. P. SPICE, London, Eng. HENRY SIMON, Manchester, Eng.

MILLS' REVERSIBLE LIME TRAY,

AND

WOODWORK

Of Every Description

NEEDED BY GAS WORKS.

SEND FOR CIRCULAR AND PRICE LIST TO

BARTLETT, HAYWARD & CO.,

Pratt and Scott Streets, Baltimore, Md.

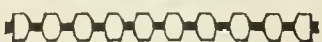
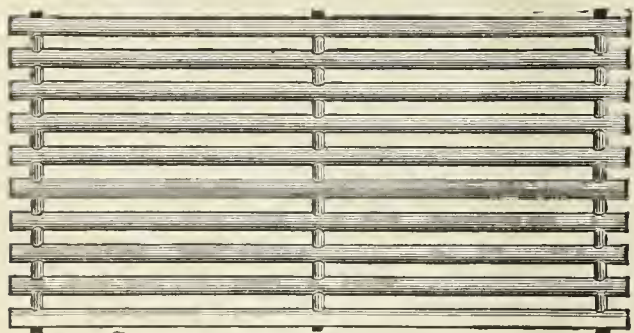

Hydraulic Main Dip Regulators, also
Check Valves, Foot Valves, Yard-
wash and Fire Hydrants.
Send for Circulars.

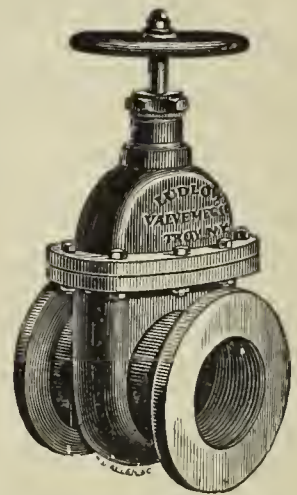

Valves.—Double and Single Gate, 1/2 in. to
48 in., outside and inside Screws. Indica-
tor, etc., for Gas, Water, Steam, and Oil.
Send for Circulars.

**VAN DUZEN
GAS & GASOLINE ENGINE**

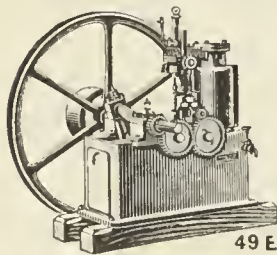

OPERATED with COAL
and OTHER MANUFAC-
TURED GASES AND
GASOLINE.

RELIABLE AND
ECONOMICAL.

Fully Warranted

VAN DUZEN
Gas & Gasoline Engine Co.
49 E. 2d St., Cincinnati, O.

A. MacKinnon Machine Co., Agts., 22 Warren St., N.Y.

**The Management of Small
Gas Works.**

BY C. J. R. HUMPHREYS.

Price, \$1.

Orders to be sent to **A. M. CALLENDER & CO.,**

42 PINE STREET, NEW YORK.

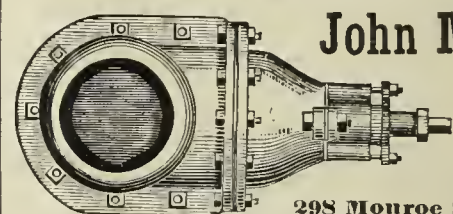

John McLean

Man'furer

**GAS
VALVES.**

298 Monroe Street, N. Y.

SPECIAL TRAYS FOR IRON SPONGE OR OXIDE OF IRON.
CHURCH'S TRAYS A SPECIALTY.

REVERSIBLE-STRONGEST-MOST DURABLE-MOST EASILY REPAIRED.

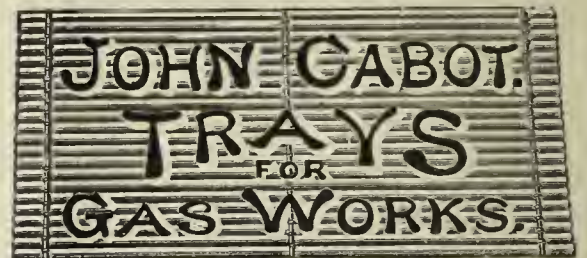

306-310 ELEVENTH AVENUE, NEW YORK.

WE ALSO MAKE THE CHEAPEST AND STRONGEST
REVERSIBLE BOLTED TRAYS IN THE MARKET.

THE CLERK GAS ENGINE CO.,
Main Office, 1012, 1014, 1016, 1018 Filbert St., Philadelphia, Pa.

WM. W. GOODWIN, Prest.

E. STEIN, Sec.

S. LEWIS JONES, Asst. Sec.

A. J. DOTY, Supt.

The utility and convenience of the Gas Engine being no longer an open question, it only remains now for intending purchasers to select the BEST. We claim for the CLERK GAS ENGINE that it is equal to any other manufactured as regards steadiness in running, simplicity, and ease of keeping in repair, and that it gives the greatest amount of power for the least money (both in first cost and expense of running) of any engine made. In support of this claim we refer to the test of the Gas Engines made under the direction of the American Institute of New York, in December, 1885, and heretofore published in these columns. These engines are especially adapted for continuous running under heavy loads, and we can refer to Engines which have run 22 hours a day for months at a time

Made in Sizes of 5, 10, 15, 20, and 25 Horse Power. All Engines Guaranteed for One Year.

ENGINEERS.

GAS AND WATER PIPES.

GAS AND WATER PIPES.

P. D. WANNER, Chairman. A. H. MELLERT, Mangr. of Wks.
R. B. KINSEY, Secretary. F. A. KNOPP, Treasurer.

SAM'L R. SHIPLEY, Pres.
HENRY B. CHEW, Tre

JAS. P. MICHELLON, Sec.
WM. SEXTON, Supt.

MELLERT FOUNDRY & MACHINE CO. Ltd.
and **READING FOUNDRY CO., Ltd.**
Reading, Pa.



Specials—Flange Pipe, Valves and Hydrants
Lamp Posts, Retorts, etc.
General Foundry and Machine Work.
JOHN FOX, Selling Agent. 160 Broadway, N.Y.

THE OHIO PIPE COMPANY,

MANUFACTURERS OF

Cast Iron Gas & Water Pipe,

BRANCH AND SPECIAL CASTINGS.

Gas-House Bench Castings, Hydraulics, Lamp Posts, Flange Pipe
and Specials, Architectural Castings, Building Columns,
Joists, Cellar Grates, Sash Weights, etc.

GENERAL FOUNDERS AND MACHINISTS.

Columbus, Ohio.

M. J. DRUMMOND,



SPECIAL CASTINGS AND LAMP POSTS.

Office, Corbin Building, 192 Broadway, N. Y.

EMAUS PIPE FOUNDRY.

DONALDSON IRON COMPANY. EMAUS, PA.



MANUFACTURERS OF

CAST IRON PIPE AND SPECIAL CASTINGS
FOR WATER AND GAS.

JOS. R. THOMAS,

No. 42 Pine Street, N.Y. City.

CONSULTING AND CONSTRUCTING

Gas Engineer and Contractor.

PLANS, SPECIFICATIONS, AND ESTIMATES
FURNISHED.

Contracts taken for all Appliances
required at a Gas Works,

Either for New Works or Extensions to Old Plants.

WM. MOONEY

(Successor to WM. FARMER)

No. 94 Liberty St., N Y. City.

GAS ENGINEER AND CONTRACTOR FOR THE ERECTION
OF GAS WORKS, OR APPARATUS OF ANY
CAPACITY.

Plans and Specifications Furnished.

WM. GARDNER,

Gas Engineer,

Lewis Block, Room 20, Pittsburgh, Pa.

Those who intend to make alterations in existing gas plants, or
who contemplate the erection of new works, will find it to their
interest to open correspondence with the above. Plans mad
and estimates furnished.

GLOUCESTER IRON WORKS,
GLOUCESTER CITY, N. J.



Cast Iron Gas & Water Pipes, Stop Valves, Fire Hydrants, Gasholders. &c.

Office, Rooms 61 and 63 Bullitt Building, 131 S. 4th St., Phila., Pa.

WARREN FOUNDRY AND MACHINE CO.,

Established 1856.

Works at Phillipsburgh, N. J.

New York Office, 160 Broadway.

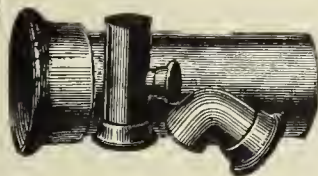

CAST IRON WATER AND GAS PIPE,

FROM TWO TO FORTY-EIGHT INCHES DIAMETER. ALSO, ALL SIZES OF

Flange Pipe for Sugar House and Mine Work. Branches, Bends, Retorts, etc., etc.

DENNIS LONG & COMPANY,

LOUISVILLE, KY.,



Manufacture Exclusively

CAST IRON GAS & WATER PIPE & SPECIAL CASTINGS
OF ALL SIZES.

King's Treatise on Coal Gas.

A standard text-book for the Engineers and Managers of Gas Works, and for all who are concerned
or take an interest in the manufacture and distribution of Coal Gas, and in the utilization of the
Secondary Products resulting therefrom; treating also of the Gas Engine, and of Gas Cooking and
Heating Appliances

In 3 Vols. Price per Vol., \$10. Sold either by Volume or in Sets.

A M. CALLENDER & CO., 42 Pine St., N. Y.

RETORTS AND FIRE BRICK.

RETORTS AND FIRE BRICK.

RETORTS AND FIRE BRICK.

J. H. GAUTIER & CO.,

CORNER OF

GREENE AND ESSEX STREETS,

JERSEY CITY, N. J.

MANUFACTURERS OF

**Clay Gas Retorts,
Gas House Tiles,
Fire Bricks, Etc. Etc.**

Ground Clay, Fire Brick and
Fire Sand in Barrels,

J. H. GAUTIER. C. E. GREGORY. C. E. GAUTIER.

BROOKLYN**Clay Retort & Fire Brick Works,**

(EDWARD D. WHITE & CO.)

Manufacturers of Clay Retorts, Fire Brick,
Gas House and other Tile.

VAN DYKE, ELIZABETH, RICHARDS & PARTITION STS.

Office, 88 Van Dyke St., Brooklyn, N. Y.

LACLEDE FIRE BRICK MFG. CO.,

MANUFACTURERS OF

Fire Brick, Gas Retorts,

AND

ST. LOUIS STANDARD SEWER PIPE.Blast Furnace and Cupola Linings, every description of Fire
Clay Material, Fire Clay Flue Linings, Chimney Tops
Dry Milled and Crude Fire Clays, etc.

OFFICE AND DEPOT

901, 903, and 905 Pine Street,

ST. LOUIS, MO.

ESTABLISHED IN 1845.

B. KREISCHER & SONS,

OFFICE FOOT OF HOUSTON ST., E. R., N. Y.

Gas Retorts,**TILES, FIRE BRICK.**

AND EVERYTHING IN THE FIRE CLAY LINE.

MANHATTAN

FIRE BRICK & ENAMELLED CLAY

RETORT WORKS**ADAM WEBER.**

**CLAY GAS RETORTS
AND RETORT SETTINGS
FIRE BRICKS, TILES, ETC.,**

Office and Works, 15th Street and Avenue C., N. Y.

Works,
LOCKPORT STATION, PA.

—ESTABLISHED 1864.—

JAMES GARDNER, JR.,

Successor to WILLIAM GARDNER & SON.

Fire Clay Goods for Gas Works.

H. A. NORTON, No. 4 CENTRAL STREET, BOSTON, MASS., Agent for the New England States.

GEO. C. HICKS,
Pres.**CHICAGO**CHAS. A. REED,
Sec. & Treas.**Retort and Fire Brick Co.,**

MANUFACTURERS OF

Fire Clay Goods of all Kinds,

AND BEST QUALITY ONLY.

Regenerative Furnaces & Water Gas Goods.

45th St., Clark to La Salle, Chicago.

GEROULD'S IMPROVED RETORT CEMENT.A Cement for patching retorts, putting on mouthpieces, and
making up all bench-work joints. This Cement is mixed ready
or use. Economic and thorough in its work. Fully warranted
o stick. For recommendations and price list address**C. L. GEROULD & CO.,**

5 & 7 Skillman St., Brooklyn, N. Y.

Western Agent, H. T. GEROULD, Mendota, Ill.

**Parker-Russell
Mining and Mfg. Co.,**

CITY OFFICE,

Mermod-Jaccard Bldg., Rooms 307 & 308,
Broadway & Locust St., St. Louis, Mo.

PROPRIETORS OF THE

OAKHILL GAS RETORT & FIRE BRICK W'KSOur immense establishment is now employed almost entirely in
the manufacture of**Materials for Gas Companies**We have studied and perfected three important points. Our re-
torts are made to stand changes of temperature, the strongest
heats of the furnace, and the abrasion of feeding and emptying.
We have the exclusive Agency for the West of the celebrated**Kloenne-Bredel Full Depth and
Semi-Recuperator Benches,**

And also furnish and build

Our Own Styles Semi-Recuperator Furnaces
for the use of Coal or Coke as fuel.

THOS. SMITH, Prest.

AUGUST LAMBLA, Vice-Prest. & Supt.

BALTIMORE**RETORT & FIRE BRICK CO.**

MANUFACTORY AT

LOCUST POINT, BALTIMORE, MD.

Clay Retorts, Blocks & Tiles

**FIRE BRICK, FIRE CLAY,
AND FIRE CEMENT.**

Red and Buff Ornamental Tiles and Chim-
ney Tops. Drain and Sewer Pipe (from
2 to 30 inches). Baker Oven Tiles
12 x 12 x 2 and 10 x 10 x 2.

WALDO BROS., 88 WATER ST., BOSTON, MASS

Sole Agents the New England States.

Boston Fire Brick Works Manufacturers of **Gas Retorts and Settings**

Under the Personal Supervision of MR. GEO. C. HICKS late of Chicago.

Fire Clay Goods of all kinds. Akron Sewer Pipe, Lime, Cement, etc. Agts. for the Arc Gas Lamp & Governing Gas Burners.

Send for Circulars and Prices to

FISKE, COLEMAN & CO., Managers, No. 62 Congress Street, Boston, Mass.

HENRY MAURER & SON,

(ESTABLISHED 1856.)

EXCELSIOR FIRE BRICK & CLAY RETORT WORKS

WORKS, Perth Amboy, N. J.

OFFICE, 418 to 422 East 23d St., N. Y.

**Clay Gas Retorts,
BENCH SETTINGS,
Fire Brick, Tiles, Etc.**

FLEMMING'S

Generator-Gas Furnace

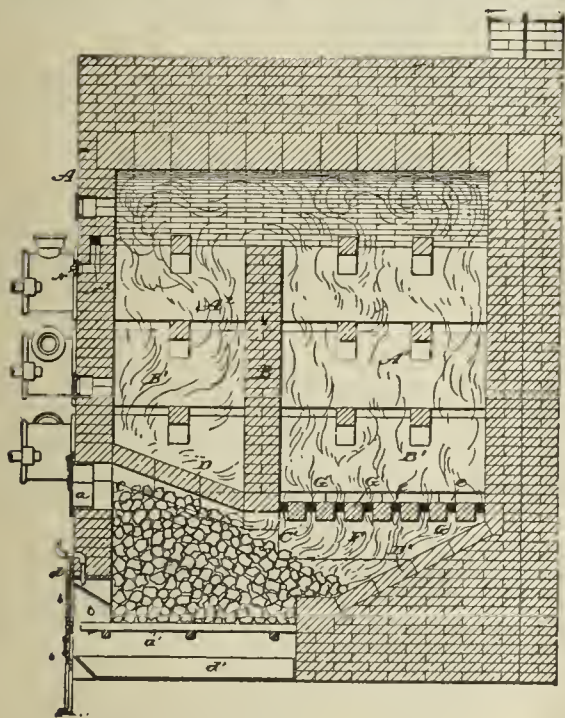

Materials furnished and Benches erected by

J. H. GAUTIER & CO., - Jersey City, N. J.

Address as above, or D. D. FLEMMING, Jersey City, N. J.

FRED. BREDEL,

CONTRACTOR FOR THE COMPLETE

Erection and Equipment of Gas Works.

SOLE PROPRIETOR OF THE

KLOENNE PATENTS

FOR NORTH AMERICA.

REGENERATIVE FURNACES.

(900 Retorts are now fired in America by the Kloenne-Bredel System.)

SELF-SEALING MOUTHPIECES.

(Over 800 Now in Use.)

Standard Condensers. Washer-Scrubbers.

TAR WASHERS FOR WATER GAS PLANTS.

(In use in the works of the Chicago Gas Lt. Co.)

GASHOLDERS.

Bredel's Automatic Gas Governor.

Refers, by permission, to Mr. Eugene Vanderpool, Newark, N. J.; Mr E. G. Cowdery, Milwaukee, Wis.; and Mr. Theo. Forstall, Chicago, Ills For further infomation, address

FRED. BREDEL,

No. 208 East Seventeenth Street, N. Y. City.

COMPOUND Condensing or Non-Condensing.
16 SIZES, 5 to 500 H. P.

Not yet equaled by any form of Engine for
HIGH FUEL DUTY AND SIMPLICITY.

STANDARD 13 Sizes in Stock.
5 to 250 H. P.
3000 in use in all parts of the Civilized World.

JUNIOR 6 Sizes in Stock,
5 to 50 H. P.
An Automatic Engine cheaper than a Slide Valve.
WELL BUILT. ECONOMICAL. RELIABLE.
Over 300 Sold the First Year.

All the above built strictly to Gauge with
INTERCHANGEABLE PARTS.
REPAIRS CARRIED IN STOCK.
SEND FOR ILLUSTRATED CATALOGUES.

**WESTINGHOUSE
ENGINES**
The Westinghouse Machine Co.
PITTSBURGH, PA. U.S.A.

SELLING DEPARTMENT IN THE UNITED STATES.

New York, 17 Cortlandt St. }
Boston, Hathaway Building, } Westinghouse,
Pittsburgh, Westinghouse Build'g, } Church, Kerr
Chicago, 156, 158 Lake St. } & Co.
Philadelphia, 608 Chestnut St. M. R. Muckle, Jr. & Co.

ST. LOUIS,

511 NORTH FOURTH ST.,

Westinghouse, Church, Kerr & Co.

Salt Lake City, 259 S. Main St. } Utah & Montana
Butte, Mont. L. Granite St. } Machinery Co.
San Francisco, 21, 23 Fremont Street, Parke & Lacy Co.
Portland, Or. 33, 35 N. Front St. Parke & Lacy Mch. Co.
Charlotte, N. C. 36 College St. } The D. A. Tompkins Co.
Atlanta, Ga. 45 S. Prior St. }
Dallas, Tex. Keating Imp. & Machine Co.
Chattanooga, Tenn., C. E. James & Co.

Newbigging's Handbook for Gas Engineers and Managers.

The present (the fifth) edition marks an important advance on those that have gone before. Considerable additions have been made to the text, and much of it has been re-written and otherwise improved. It extends to 524 pages, and contains 193 illustrations. Price, Cloth, \$6.00.

A. M. CALLENDER & CO., - - - - No. 42 Pine Street, N. Y. City.

DAVIS & FARNUM MFG. CO.,

WALTHAM, MASS.

PRINCIPAL OFFICE AND WORKS, Waltham, Mass.

BOSTON OFFICE, Room 55, Mason Building, 70 Kilby Street.

SINGLE, DOUBLE,
AND
TRIPLE LIFT

Gas holders.

OF ANY CAPACITY.

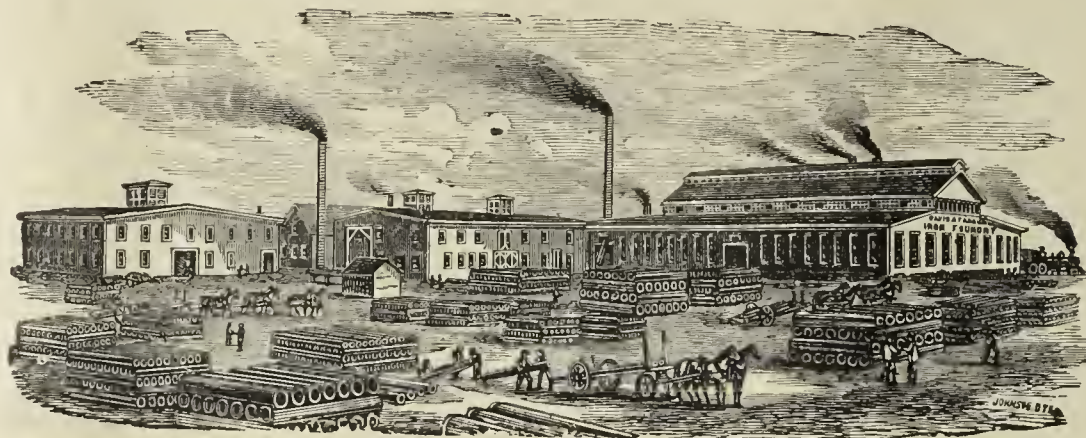

TUBULAR, PIPE,
AND
SINUOUS FRICTION

Condensers.

OF ALL SIZES.

IRON ROOF FRAMES AND FLOORS.

Purifying Boxes, Center Seal or Valve Connections, Bench Work.

Reversible Lime Trays.

SELF-SEALING AND PRESSED STEEL MOUTHPIECE LIDS.

Coke Barrows, Coal Wagons, and all Apparatus Requisite for a Complete Gas Plant.

— ALSO —

Gas and Water Pipe, Flanged Pipe,

Sugar House Work, and Special Castings of all Descriptions.

Established 1861.

Incorporated 1881.

KERR MURRAY MFG. CO.,

FORT WAYNE, IND.

Those who are in need of

Holdings or Gas Works Apparatus of any Description,

AND OF THE LATEST IMPROVEMENTS,

will find it to their interest to

GET AN ESTIMATE FROM US

before placing their order.

As we make a Specialty of this Class of Work, and are Practical Builders and Manufacturers of same,

with our long years of experience in the business,

WE CAN GUARANTEE YOU SATISFACTION.

Estimates, Plans and Specifications Furnished on Application.

BARTLETT, HAYWARD & CO.

Baltimore, Md.

Triple Double, & Single-Lift
GASHOLDERS.

Iron Holder Tanks.

ROOF FRAMES.

Cirders.

BEAMS.

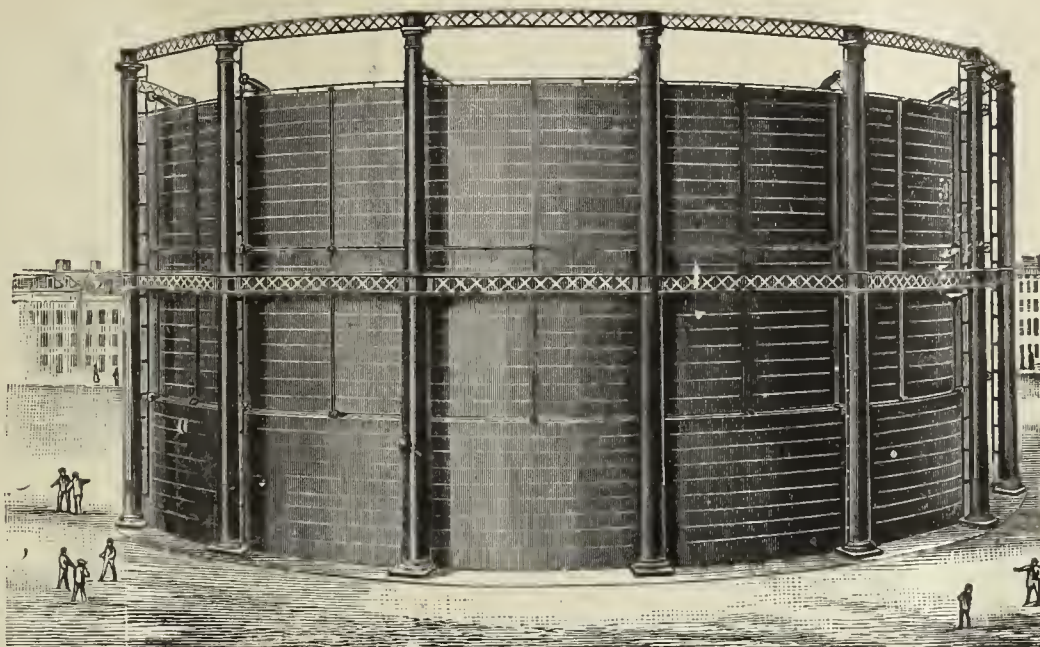

PURIFIERS.

CONDENSERS.

Scrubbers.

BENCH CASTINGS.

OIL STORAGE TANKS.

Boilers.

The Wilkinson Water Gas Process.

THIRTY-CANDLE, NON-CONDENSABLE, FIXED GAS. THE MOST SUCCESSFUL GAS PROCESS IN OPERATION.

Munich Regenerative Furnace, System Drs. Schilling & Bunte.

HAZELTON BOILERS.

Gas Works Designed and Constructed.

Pascal Iron Works. ESTABLISHED 1821. Delaware Iron Works.

MORRIS, TASKER & CO.,

INCORPORATED.

OFFICE, 224 SOUTH THIRD STREET, - - PHILADELPHIA, PA.

CONTRACTORS, BUILDERS, AND MANUFACTURERS OF

Gas, Water & Sugar Works

Bench Castings.

Condensers.

Scrubbers.

Purifiers.

Hyd. Carriages.

Iron Floors,

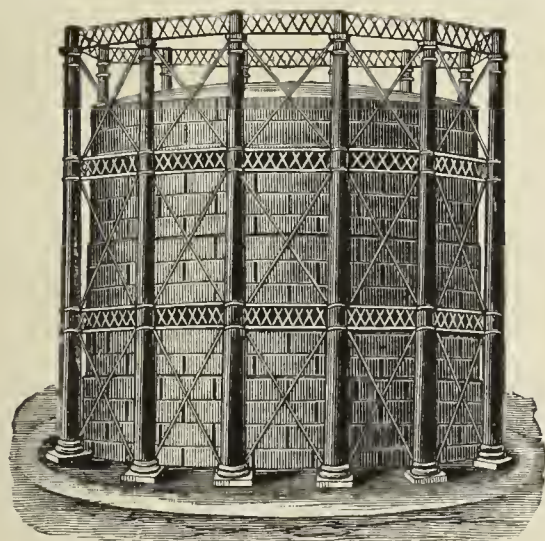

Iron Roofs.

Street Stops,

Valves, etc.

Stand-Pipes.

Water & Oil

Tanks, all Sizes.

Single, Double, and Triple-Lift Gas Holders.

SELF-SEALING RETORT LIDS. STAMPED STEEL RETORT LIDS.

Locomotive Water Columns, Filters, etc. Boiler Tubes, Wrought Iron Pipe & Fittings

Plans, Specifications and Estimates for all kinds of Machinery furnished on application.

Foundries & Works,
MILLVILLE, FLORENCE,
and CAMDEN, N. J.

R. D. WOOD & CO.,

Engineers,
Iron Founders,
and
Machinists.

400 Chestnut St., PHILADELPHIA, PA.

MANUFACTURERS OF

CAST IRON PIPE,

Gas Holders,

SINGLE, DOUBLE, AND TRIPLE LIFTS, WITH
OR WITHOUT WROUGHT IRON
OR STEEL TANKS.

PURIFIERS, CONDENSERS.

Scrubbers.

BENCH WORK.

Iron Floors and Roofs, Plate Girders.

Heavy Loam Castings.

HYDRAULIC WORK.

Lamp Posts, Valves, Etc.

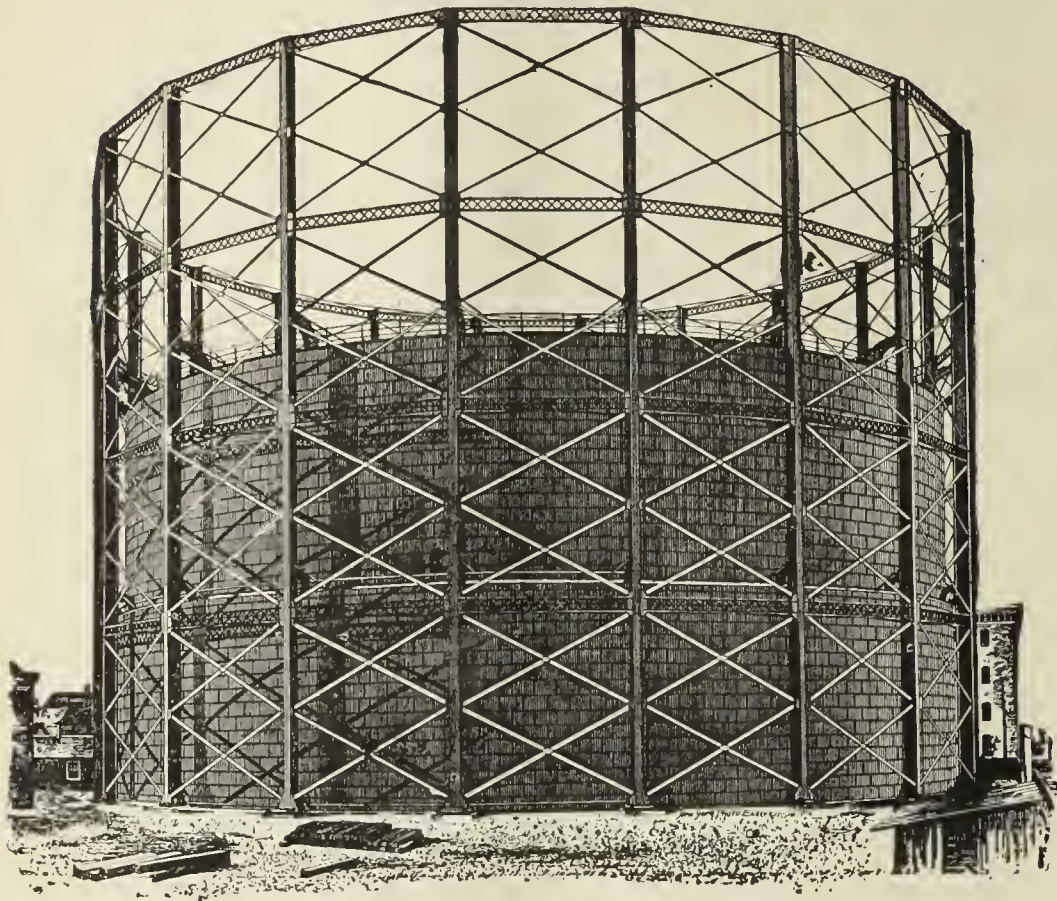

SMITH & SAYRE MFG. COMPANY,

G. G. PORTER, Prest.

245 Broadway, N. Y.

CHAS. W. ISBELL, Sec'y.

Machinery & Apparatus for Gas Works

Drawings, Plans, and Estimates Furnished for the Improvement, Extension, or Alteration of Gas Works, or for the Construction of New Works.

Mackenzie's Patent Rotary and Steam Jet Gas Exhausters, Governors, Compensators, Condensers, Washers, Scrubbers. Isbell's Patent Automatic Street Pressure Governor, Gas and Water Valves, Hydraulic Main Dip Regulator, Bench Castings, etc. Purifying Boxes and "Standard" Scrubbers. Isbell's Patent Self-Sealing Retort Doors.

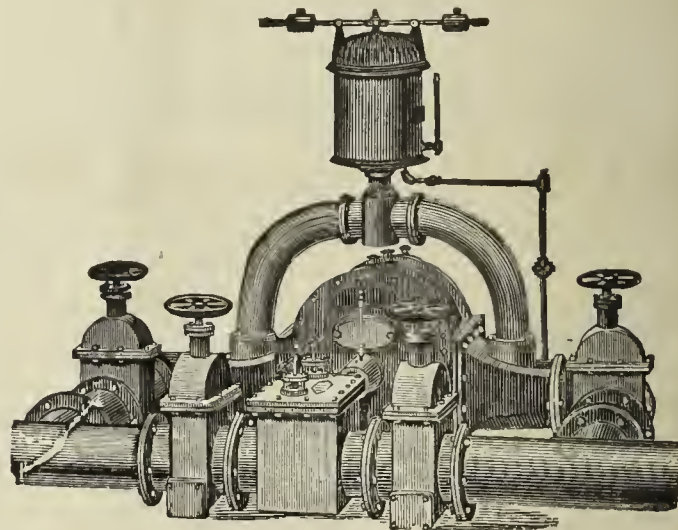

THE BRENNER SELF-SEALING RETORT DOOR.

Simple, Strong, and Durable.

CLOSES ABSOLUTELY TIGHT & IS LOCKED BY A CAM LEVER. ALL NECESSARY ADJUSTMENT FOR WEAR PROVIDED.

BUILT BY

SMITH & SAYRE MFG. CO.,

No. 245 Broadway, - - - New York City.

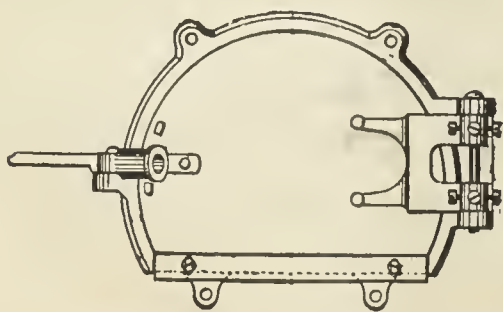

Brenner Self-Sealing Retort Door.

WILLIAM B. LUNDIE, Superintendent of the 42d Street Station of the Consolidated Gas Company, of New York, writes, under date of Jan. 4, 1889:

"We have 320 Brenner Self-Sealing Lids in use at this Station, built by the Smith & Sayre Mfg. Co. They require very little attention, and are the best of the kind that I have seen, giving entire satisfaction."

GAS WORKS APPARATUS AND CONSTRUCTION.

GAS WORKS APPARATUS AND CONSTRUCTION.

JAMES R. FLOYD & SONS,

(SUCCESSORS TO HERRING & FLOYD)

Oregon Iron Works,

W. 20th & 21st. Sts., bet. 10th & 11th Aves.,

NEW YORK CITY.

Engineers and Contractors

FOR THE

CONSTRUCTION OF GAS WORKS.

MANUFACTURERS OF

All Kinds of Castings and General Ironwork

FOR

GAS APPARATUS.

Bench Castings, Regenerative and Half Regenerative Furnace Castings.

Condensers, Scrubbers, Purifiers, Street Drips and Connections,

Valves,

Hydraulic Hoisting Purifier Carriage, Self-Sealing Retort Lids, Improved Valve Stand and Indicator,

Seller's Cement.

Plans, Specifications, and Estimates furnished for Construction of New or Alteration of Old Works.

CONTINENTAL IRON WORKS.

THOS. F. ROWLAND, Prest.

WARREN E. HILL and CHAS. H. CORBETT, V-Prests.

THOS. F. ROWLAND, JR., Sec. & Tr

P. O. Station G., BROOKLYN, N. Y.

ENGINEERS AND MANUFACTURERS OF

Gas Holders

CONDENSERS, SCRUBBERS, VALVES,

PURIFIERS, SELF-SEALING RETORT LIDS

Hydraulic Mains,

And all other articles connected with the manufacture and distribution of Gas.

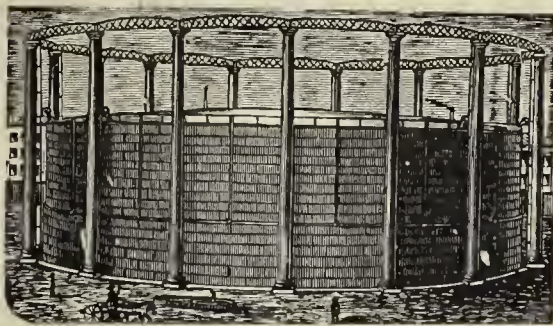

H. RANSHAW, Prest. & Mangr.

WM. STACEY, Vice-Prest.

T. H. BIRCH, Asst. Mangr.

R. J. TARVIN, Sec. & Treas.

STACEY MFG. CO.,

MANUFACTURERS OF

Single and Telescopic Gasholders,

IRON ROOFS, BRIDGES, LAMP POSTS,

Water and Oil Tanks, Coal Elevator Cars,

COKE CRUSHERS, BENCH CASTINGS,

And all kinds of Wrought and Cast Iron Work used in the erection of Coal and Oil Gas Works Rolling Mill Machinery and Heavy Castings a Specialty.

Foundry:

33, 35, 37 & 39 Mill Street.

Wrought Iron Works:

16, 18, 20, 22, 24 & 26 Ramsey Street:

Cincinnati, Ohio.

Bouton Foundry Co.,

FOUNDERS AND MACHINISTS,

CHICAGO, ILL.

Gas Works Apparatus,

PURIFIERS, CONDENSERS,

Bench Work

SPECIALS, LAMP POSTS,

SCRUBBERS,

Iron Roofs and Floors.

Plans and Estimates furnished for new works or extensions of old works.

1842. **DEILY & FOWLER,** 1890.

Laurel Iron Works.

Address, No. 39 Laurel Street, Philadelphia, Pa.

BUILDERS OF

GASHOLDERS,

Single and Telescopic.

HOLDERS BUILT 1884 TO 1888, INCLUSIVE:

- | | | | | |
|----------------------------|-----------------------------|---------------------------|--------------------------|------------------------|
| Newport, R. I. | Long Island City, N. Y | Port Chester, N. Y. | Malden, Mass. | West Chester, Pa. (2d) |
| Portland, Oregon. | Mac on, Ga. | New Rochelle, N. Y. | Paducah, Ky. | Lancaster, Pa. (3d) |
| Allegheny, Pa. (2d.) | York, Pa. | Salem, N. J. (3d) | Norwich, Conn. | Fac ny, Pa. (two) |
| Atlanta, Ga. (2d.) | Chester, Pa. | Omaha, Neb. (2d) | Seattle, W. T. | Mount Vernon, N. Y. |
| N.Y. City (Central Gas Co) | Hazleton, Pa. (2d.) | Lynn, Mass. (2d) | San Diego, Cal. | Binghamton, N. Y. |
| Lynchburg, Va. (2d.) | State Island, N. Y. | Little Rock, Ark. | Northern Gas Lt. Co., of | Concord, N. H. |
| Saylesville, R. I. | Saugerties, N. Y. | Irrington, N. Y. | New York N. Y. | Dover, Del. (2d) |
| Rondout, N. Y. | Clinton, Mass. (Lan. Mills) | South Boston, Mass. | Westerly, R. I. | Calais, Me |
| Atlantic City, N. J. | Chattanooga, Tenn. | Rye, N. Y. (2) | Willimantic, Conn | New Loudon, Conn. (3d) |
| Augusta, Ga. | Galveston, Texas. (3d.) | Woodstock, Ont. | Montclair, N. J. | West Chester, N. Y. |
| Waltham, Mass. (2) | Omaha, Neb. | Malden, Mass. | Attleboro, Mass. | Bay Shore, L. I. |
| Mahanoy City, Pa. | Fort Plain, N. Y. | Staten Island, N. Y. (2d) | Santa Cruz, Cal. | Washington, D. C. |
| New Castle, Pa. | Brunswick, Ga. | Woodstock, Ont. | Erie, Pa. (2d) | |

WM. HENRY WHITE,

No. 32 Pine Street, - - - New York City.

ENGINEER AND CONTRACTOR FOR THE

Erection and Extension of Gas, Water, and Electric Light Works.

SOLE REPRESENTATIVE OF THE

McILHENNY REGENERATOR FURNACE PATENTS

And the Martin Water Gas Process.

Edison Incandescent and American Arc Electric Light Plants Installed.

Correspondence with Gas Companies contemplating extending or improving their Plants respectfully invited. Plans and Estimates Furnished.

GAS COALS.

CANNEL COALS.

GAS ENRICHERS.

JAMES D. PERKINS. **PERKINS & CO.,** F. SEAVERN.
 228 & 229 Produce Exchange, New York.
 Cable Address, "PERKINS, NEW YORK." Post Office Box 3695, New York.

GENERAL SALES AGENTS FOR

The Youghiogeny River Coal Company's
OCEAN MINE YOUGHIOGHENY GAS COAL.

HON. W. L. SCOTT, Prest. M. H. TAYLOR, Vice-Prest.

This Colliery is located at SCOTT HAVEN, PA., in the center of the Youghiogeny Gas Coal District, and produces the ONLY RELIABLE YOUGHIOGHENY COAL for gas purposes. (See Map on p. 87 of this JOURNAL, Feb. 16, '85.)

POINTS OF SHIPMENT,

Locust Point, BALTIMORE. Pier No. 62, PHILADELPHIA.

Also, SOLE AGENTS for the

BRECKENRIDGE CANNEL,
OF KENTUCKY.

Within the past two years we have delivered this Cannel to over ONE HUNDRED COMPANIES IN THIRTY-THREE DIFFERENT STATES, and it is now in use in some of the large Gas Works

On the Continent and in South America,

where it successfully competes with the Australian Shale. It is the ONLY AMERICAN GAS CANNEL of sufficiently high grade to warrant EXPORTATION TO EUROPE AND SOUTH AMERICA, and it is the only economical substitute for OIL OR NAPHTHA. ONE GROSS TON will produce

10,000 Cubic Feet of 75 Candle Gas,	} equal to {	750,000 Candle Feet of Gas, and 26 Bushels of merchantable Coke weighing 900 Pounds
or 12,500 " " 60 " "		
or 15,000 " " 50 " "		

This is the ONLY GAS CANNEL that will produce a REALLY MERCHANTABLE COKE. It can be delivered in parcels of one carload or more to any point in the United States or Canada. Cargo shipments of any size required can be made from NEW YORK, PHILADELPHIA, BALTIMORE, or NEWPORT NEWS. Samples will be sent and particulars of price, etc., forwarded upon application to above address.

JAMES & WILLIAM WOOD,
Gas and Cannel Coal Contractors,

No. 40 St. Enoch Sq., Glasgow. No. 2 Talbot Court, London.

Proprietors of the BATHVILLE COLLIERIES (which produce the celebrated BOGHEAD CANNEL), Shields, Shieldmuir, Drumpeller, and other Collieries. This Firm offer

STANDARD CANNELS,

Unequaled as Gas Enrichers.

Also, WEST FAIRMONT GAS COAL, of W. Va.

Analyses, prices, and all further information furnished on application to
 Agency for U. S., Room 70 Nos. 2 & 4 Stone St., N.Y. City.

The Standard Oil Company,

REFINERS OF

NAPHTHA AND GASOLINES.

ALSO MANUFACTURERS OF

A Special Grade of Naptha for
 Gas Companies

FOR ENRICHING COAL GAS.

Correspondence solicited.

No. 43 Euclid Avenue, Cleveland, Ohio.

To Gas Companies.

We make to order CAP BURNERS to burn any amount under a stated pressure. Send for samples.

Also, SERVICE CLEANERS, DRIP PUMPS, and STREET MAIN PROVING APPARATUS.

C. A. GEFROER,

248 N 5th Street, Phila., Pa.

COKE CRUSHERS.

Newburgh Orrel Coal and Coke Co.

MINERS AND SHIPPERS OF

STEAM, SMITHING, AND GAS COALS,
Foundry and Crushed Coke.

Home Office, 33 S. Gay Street, Baltimore, Md.

J. HARRY LEE, President.

Shipping Wharves, Locust Point, Baltimore.

The Despard Gas Coal Co.,

MINERS AND SHIPPERS OF

DESPARD GAS COAL,

AND MANUFACTURERS OF

COKE.

MINES, Clarksburg, Harrison Co., W. Va.

WHARVES, Locust Point, Baltimore, Md.

OFFICE, 225 E. German St., " "

ROUSSEL & HICKS, } AGENTS. } BANGS & HORTON,
71 Broadway, N. Y. } 60 Congress St., Boston.

GAS COALS.

GAS COALS.

THE

PENN GAS COAL CO.

OFFER THEIR

Coal, Carefully Screened & Prepared for Gas Purposes.

Their Property is located in the Youghiogheny Coal Basin, near Irwin and Penn Stations on the Pennsylvania Railroad, and on the Youghiogheny River.

Principal Office:

209 SOUTH THIRD STREET, PHILA., PA.

Points of Shipment:

Pennsylvania Railroad Piers; Greenwich Wharves, Delaware River; Pier No. 1 (Lower Side), South Amboy, N. J.

Chesapeake & Ohio Railway Coal Agency,

FOR THE SALE OF THE

Superior Kanawha Gas Coals, Cannelton Cannel,
Also, SPLINT AND STEAM COALS,

From the Kanawha and New River Regions, on the line of the Chesapeake & Ohio R'way.

C. B. ORCUTT, General Agent, - - No. 1 Broadway (Room 217) New York City.

FRANCIS H. JACKSON, Prest. EDMUND H. MCCULLOUGH, V.-Prest. CHAS. F. GODSHALL, Treas. H. C. ADAMS, Sec.

THE WESTMORELAND COAL CO.

Chartered 1854.

Mines situated on the Pennsylvania and the Baltimore and Ohio Railroads, in Westmoreland County, Penn.

POINTS OF SHIPMENT:

PHILADELPHIA, BALTIMORE, SOUTH AMBOY, N. J.,
WATKINS (SENECA LAKE), N. Y.

Since the commencement of operations by this Company its well-known Coal has been largely used by the Gas Companies of New England and the Middle States, and its character is established as having no superior in gas-giving qualities, and in freedom from sulphur and other impurities.

Principal Office, 224 South 3d St., Phila., Pa.

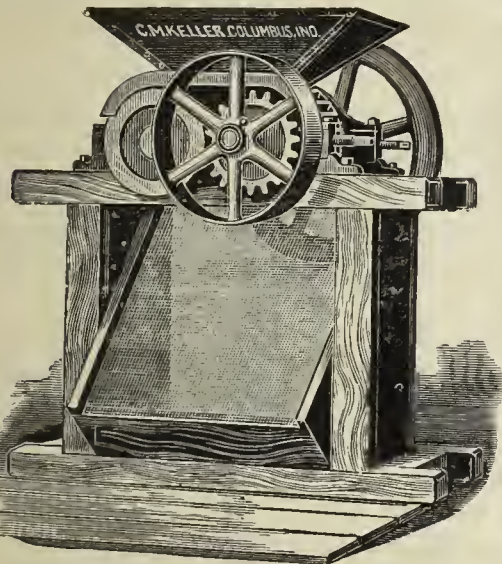

Keller's Adjustable Coke Crusher.

SIMPLE, STRONG, AND DURABLE.

C. M. Keller, Sec. & Supt. Gas Lt. & Coke Co. Columbus, Ind.

Correspondence Solicited.

King's Treatise on Coal Gas.

The most complete work on Coal Gas ever published.

Three Vols. Bound, \$30.

BOOKS.

DISTILLATION OF COAL TAR AND AMMONIACAL LIQUOR.

By GEORGE LUNGE. Price \$12.50.

A TREATISE ON THE COMPARATIVE COMMERCIAL VALUES OF GAS COALS AND CANNELS.

By DAVID A. GRAHAM. 8vo., Cloth. Price \$3.

Orders for these books may be sent to this office.

A. M. CALLENDER & CO.,

42 PINE ST., N. Y. CITY

The American Gas Engineer and Superintendent's Handbook.

By WILLIAM MOONEY.

Consisting of Rules, Reference Tables, and Original Matter Pertaining to the Manufacture, Manipulation, and Distribution of Illuminating Gas.

350 Pages, Full Gilt Morocco.

\$3.00.

A. M. CALLENDER & CO., 42 Pine St., N. Y.

JOHN J. GRIFFIN & CO.,

Nos. 1513, 1515, 1517 & 1519 Race Street, PHILADELPHIA.
52 Dey St., NEW YORK. 75 N. Clinton St., (FRED. R. PERSONS, Mangr.) CHICAGO.

MANUFACTURERS OF

METERS FOR MEASURING GAS

IN ANY VOLUME.

Provers, Gauges, Registers, Etc., Etc

EXPERIMENTAL APPARATUS FOR QUANTITATIVE AND QUALITATIVE ANALYSIS.

Careful and Prompt Attention paid to Repairing of all kinds of Meters and Apparatus.

Estimates Cheerfully Furnished.



Dry Gas Meters.

With 40 years' experience and the best facilities for manufacturing, is enabled to furnish reliable work and answer orders promptly.

NATHANIEL TUFTS,

No. 153 Franklin Street, Boston, Mass.,

MANUFACTURER OF

DRY GAS METERS.

Station Meters of any Capacity.

Test and Experimental Meters, Pressure Registers, Pressure Gauges, Pressure and Vacuum Gauges.

METER PROVERS, PHOTOMETERS, STREET LANTERNS, ETC., ETC.

Patent Cluster Lanterns for Street Illumination.

HAROLD J. BELL.

BELL & JONES,

S. LEWIS JONES.

No. 12 North Ninth Street, Philadelphia, Pa. Works at Royersford, Pa.

MANUFACTURERS OF

GAS METERS, STATION AND EXPERIMENTAL METERS,
Meter Provers, Pressure Gauges, and All Other Gas Appliances in Our Line.

WE REPAIR ALL KINDS AND MAKES OF METERS, AND THE WORK GUARANTEED.

High Pressure Meters for Natural Gas, in Iron Cases, guaranteed to stand 300 lbs. Pressure.
Gas Cooking and Heating Stoves, Hot Plates, Cake Griddles, Waffle Bakers, Boiling Stoves, Laundry and Tailors' Iron Heaters. Hotel and Cafe Ranges a Specialty.

Correspondence Solicited.

Estimates Furnished.

A. HARRIS.

E. L. HARRIS.

J. A. HARRIS.

Established 1849.

HARRIS BROS. & CO.,

Twelfth and Brown Streets, Philadelphia.

Manufacturers of Wet and Dry Gas Meters,

STATION METERS, METER PROVERS,

EXPERIMENTAL METERS, SHOW OR GLAZED METERS,

Pressure and Vacuum Registers, Gauges, Photometers, Drip and Bell Pumps, Etc., Etc.

PROMPT ATTENTION GIVEN TO ALL ORDERS. METERS THOROUGHLY REPAIRED. ESTIMATES FURNISHED FOR STATION METERS OF ALL SIZES. CORRESPONDENCE SOLICITED.

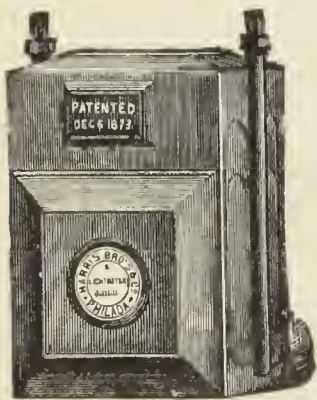

GAS METERS.

GAS METERS.

GAS METERS.

GEO. J. MCGOURKEY, Prest.

WM. H. MCFADDEN, Vice-Prest. (Phila.)

WM. N. MILSTED, Gen. Supt. and Treas. (New York).

WM. H. DOWN, Sec.

THE AMERICAN METER CO.

WET AND DRY GAS METERS.

PRESSURE REGISTERS.

METER PROVERS.

STATION METERS.

PRESSURE & VACUUM REGISTERS.

PORTABLE TEST METERS.

EXHAUSTER GOVERNORS.

PRESSURE & VACUUM GAUGES.

EXPERIMENTAL METERS.

DRY CENTER VALVES.

CRESSON GAS REGULATORS.

AMMONIA TEST METERS.

GOVERNORS FOR GAS WORKS

MARSLAND WATER METERS.

BAR & JET PHOTOMETERS.

Manufactories:

512 West 22d St., N. Y.

Arch & 22d Sts., Phila.

GAS STOVES.

SUGG'S "STANDARD" ARGAND BURNERS,

SUGG'S ILLUMINATING POWER METER,

Wet Meters, with Lizar's "Invariable Measuring" Drum.

Agencies:

177 Elm Street, Cincinnati.

244 & 246 N. Wells Street, Chicago.

310 North Second Street, St. Louis.

222 Sutter Street, San Francisco.

HELME & McILHENNY,

(Established 1848.)

GAS METER MANUFACTURERS,

Nos. 1339 to 1349 Cherry Street, Philadelphia, Pa.,

WET AND DRY GAS METERS, STATION METERS, EXPERIMENTAL METERS, METER PROVERS,

Center Seals, Pressure Registers, Governors, Indicators, Photometers, and all other kinds of Apparatus for use in Gas Works.

FOULIS' PATENT STATION AND DISTRICT GOVERNORS.

REPAIRING DEPARTMENT.—We employ a special force of skilled workmen repairing meters of all makers.

WM. WALLACE GOODWIN, President and Treasurer.

E. STEIN, Vice-President.

H. B. GOODWIN, Secretary and Superintendent.

THE GOODWIN GAS STOVE AND METER CO.,

Successors to W. W. GOODWIN & CO.

1012, 1014 and 1016 Filbert St., Phila., Pa.

142 Chambers St., New York City.

76 Dearborn, St., Chicago, Ills.

WALDO BROTHERS, Agents, 88 Water Streets, Boston, Mass.

MANUFACTURERS OF

DRY AND WET GAS METERS,

Station Meters (square, cylindrical, or in staves), Glazed Meters, King's and Sugg's Experimental Meters, Lamp Post Meters, etc., etc. Meter Provers (sizes 2, 5, and 10 feet), Pressure Gauges of all kinds, Pressure Registers, Pressure and Vacuum Registers, Pressure Indicators (sizes 4, 6, and 9 inch), King's Pressure and Vacuum Gauges, Dry and Wet Center Seals, Dry and Wet Governors, Exhauster Governors, Photometers of all descriptions. Letheby's Sulphur and Ammonia Test Apparatus complete. Also, Testing and Chemical Apparatus of all kinds, and of the most perfect description, for all purposes relating to Gas.

Manufacturers of the "SUN DIAL" GAS STOVES, for Cooking and Heating.

Goodwin's Improved Lowe's Jet Photometer.

Agents for Bray's Patent Gas Burners and Lanterns.

Special attention to Repairs of Meters and all Apparatus connected with the business. All work guaranteed first-class in every particular. Orders filled promptly.

G. B. EDWARDS, Manager, New York.

S. S. STRATTON, Manager, Chicago.

D. McDONALD & CO.,

GAS METER MANUFACTURERS.

(Established 1854.)

51 Lancaster St., Albany, N. Y. 34 & 36 West Monroe St., Chicago, Ill.

STATION METERS, EXPERIMENTAL METERS, METER PROVERS, PRESSURE & VACUUM REGISTERS, PRESSURE GAUGES, ETC.

Also STAR GAS STOVES, RANGES, and HEATING STOVES.

We use only the very best materials, and employ the most skilled labor, and by our long experience (36 years) and personal supervision of every detail, we feel justified in assuring the public that our goods will give perfect satisfaction. Every Meter emanating from our establishment will bear the State Inspector's BADGE, and will be fully warranted by us. Our Annual and Calendar will be sent to Gas Companies upon application.

WM. WALLACE GOODWIN, President. E. STEIN, Vice-President. H. B. GOODWIN, Sec. & Supt. G. B. EDWARDS, Mang'r, New York. S. S. STRATTON, Mang'r, Chicago.

THE GOODWIN GAS STOVE AND METER CO.,

1012-18 Filbert St., Phila., 142 Chambers St., N. Y., 76 Dearborn St., Chicago.

Agents, WALDO BROTHERS, 88 Water Street, Boston.

SOLE MANUFACTURERS OF THE

"SUN DIAL" GAS STOVES,

The Most Economical, Efficient, and Durable Gas Stove Made.

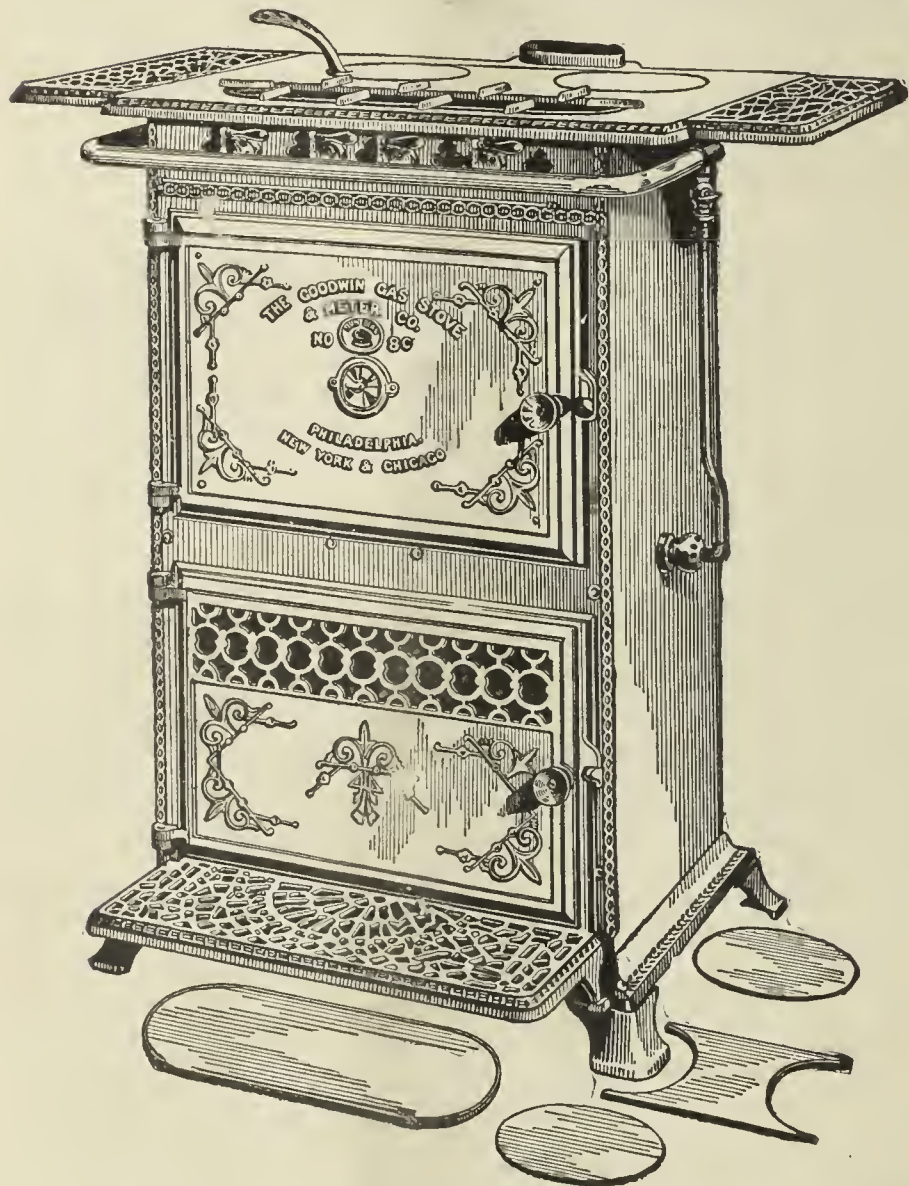

GAS COOKING STOVE, No. 8 C.

SIZE.

Stove.	Oven.	Roaster.	Top.	Length over Extension Shelves,
37 in. high.	12 in. high.	12 in. high.	24 in. long.	36 in.
20 in. wide.	17½ in. wide.	18 in. wide.	21 in. wide.	
	12 in. deep.	13 in. deep.		

This Stove has four burners on top, and double oven burner. Consumption of gas with all burners in use, 42 feet per hour, at 1 inch pressure. The top is made in sections, so that a greater variety of cooking utensils may be used. By lifting out the covers and crosspieces and putting in a suitable forked ring, which is sent with each stove, a wash boiler or other large utensil may be set over two burners. Our No. 87 GRIDDLE also fits in the same position. The roasting oven is provided with a cast-iron door.

All Fittings are Nickel-Plated.



GAS COOKING STOVE, No. 7 B.

SIZE.

Stove.	Oven.	Roaster.	Top.	Length over Extension Shelves,
31 in. high.	9½ in. high.	10 in. high.	21 in. long.	32 in.
17 in. wide.	14½ in. wide.	15 in. wide.	16 in. wide.	
	12 in. deep.	13 in. deep.		

This Stove has three boiling burners in the Top or Hot Plate, and one single oven burner.

This cut represents our New Style Cooking Stove. As will be seen, it has an ornamented cast-iron Base and Front, and extension shelves. The Oven Burner, which is atmospheric (unless otherwise ordered), is of an entirely new and improved pattern (patent). The ovens are of greater capacity than those of the old style. The Top, in conjunction with the Outlet Pipe, is designed to carry off all the products of combustion, if desired, but they are also supplied with a loose ring which converts it into an ordinary open top stove.

The consumption of this Stove is 35 cubic feet per hour at 1 inch pressure, with all Burners in use.

All Fittings are Nickel-Plated.

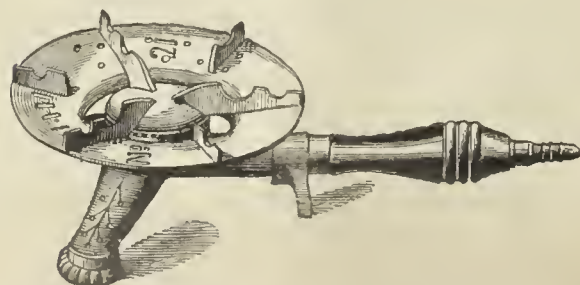

"RADIANT" BOILING STOVE, WITH REGENERATIVE BURNER.

Size, 6½ inches diameter, 3 inches high. Consumption, 6 feet per hour at 1 in. pressure.

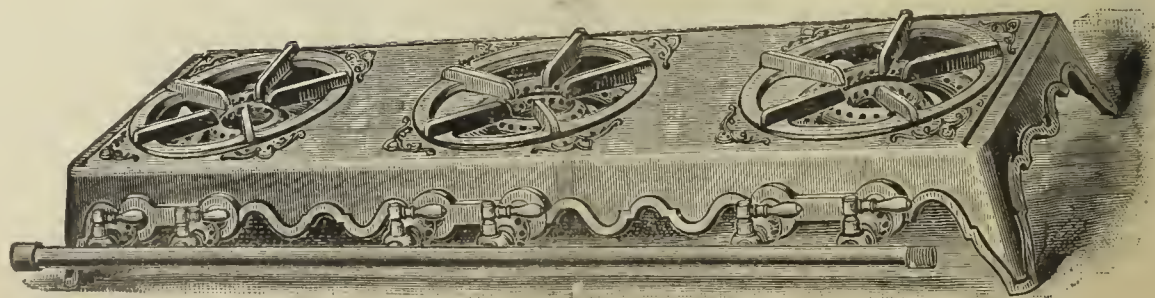

HOT PLATE, No. 111.

Size, 36 in. long, 12 in. wide, with three double burners, 6 taps. Consumption, with all burners in use, 36 cubic feet per hour, with 1 in. pressure. ½ in. supply pipe should be used where the pressure is 1 in. or over.

THE AMERICAN

GAS LIGHT JOURNAL

REDMAN & KENNY, N. Y.

PUBLISHING OFFICE No. 42 PINE STREET

DEVOTED TO THE INTERESTS OF ILLUMINATION, VENTILATION, WATER SUPPLY AND DISTRIBUTION, & GENERAL SCIENCE.

VOLUME LII.—No. 18.
Whole No. 778.

NEW YORK, MONDAY, MAY 5, 1890.

{ \$3 PER ANNUM,
IN ADVANCE.

A. M. CALLENDER & CO., Proprietors. C. E. SANDERSON, Manager.
JOS. R. THOMAS, C.E., Editor. T. J. CUNNINGHAM, Asst. Editor.

ENTERED AT THE POST OFFICE AT NEW YORK, N. Y.
AS SECOND CLASS MATTER.

Published on each Monday of the year, at No. 42 Pine Street, N. Y.

Terms of Subscription, Including Postage.—For the United States and Canada, \$3 per annum. European countries, \$4.50 (19 shillings—22½ francs). All payments to be made in advance. Single copies, 10 cents.

Remittances should be made either by post-office order, registered letter, or bank draft on New York, payable to the order of A. M. Callender & Co.

Collections are invariably made directly from this office, for subscriptions, advertisements, etc. We have agents to solicit the same, but they are not authorized to receipt for money.

Correspondence.—Wishing to make this JOURNAL a gazette of intelligent discussion to those of our readers who may wish to gain or give information on the subjects to which its columns are devoted, correspondence is solicited for publication from all who make the study of those subjects a pleasure or a profession.

The American News Company, Nos. 39 and 41 Chambers street, New York, are agents for this JOURNAL. Newsdealers will send orders to them.

Books.—We will forward by express, at publisher's lowest rates, any book—scientific or otherwise—to any address in the United States or Canada. No books will be sent C. O. D.

CONTENTS.

An Asterisk (*) denotes an illustrated article.

OFFICIAL NOTICE—

Western Gas Association..... 621

EDITORIALS—

Briefly Told..... 622

The Paper List for the St. Louis Convention—The Gas Apparatus Exhibition at St. Louis—A Correction—Notes.

The Market for Gas Securities..... 622

Labor-Saving Appliances for the Manufacture of Coal Gas, by Wm. Mooney, C. E..... 623

*Jones' Safety Device for Gas or Air Pipes..... 624

Profit Sharing..... 625

The Waste of Raw Material in Gas Manufacture..... 627

Life and Efficiency of Electric Arc Light Carbons, by L. B. Marks. 628

Notes on the Action of Lubricants..... 629

ITEMS OF INTEREST FROM VARIOUS LOCALITIES..... 630

Cheaper Gas for Sioux City, Ia.—Sale of the Decatur (Ala.) Company—Strike at Elizabethtown, N. J.—Suit for Damages—Cheaper Gas for Van Wert, O.—Orders on the Books of the Davis & Farnum Company—Annual Meeting, Chicago Gas Trust—Removing the Meters, Newark, N. J.—New Gas Company—Public Lighting, Paducah, Ky.—Heating and Cooking by Gas, East Saginaw, Mich.—Annual Meeting, Ottawa, Canada—The Charleston, S. C., Company to Take up Electric Lighting—Gas Company for Fort Benton, Mich.—Cheaper Gas for Joplin, Mo.—In Favor of Defendant—The Louisville Company to Take up Electric Lighting—The Committee on Manufactures Reports Adversely—The Laclede Company and the Cheap Gas Ordinance—Cheaper Gas for Lynn, Mass.—The Projected Opposition for Marlboro, Mass.—And Many Other Items.

Steel-Melting by Water Gas..... 633

Discharge of Steam through Orifices..... 633

An Ingenious Device for Lighting the Bottom of the Sea..... 633

[OFFICIAL NOTICE.]

Western Gas Association.

SECRETARY'S OFFICE, WESTERN GAS ASSOCIATION, }
QUINCY, ILLS., April 28, 1890. }

The Thirteenth Annual Meeting of the Western Gas Association will be held at the Lindell Hotel, St. Louis, Mo., on the 21st, 22d and 23d days of May. The hall in which the business sessions of the Association will be conducted is within the hotel building, is very commodious, quiet, and in every way excellently well adapted to our requirements. The hotel management has granted on this occasion the following rates: For single room and board, \$2.75 per day; for room with bath, \$3.25 per day. These rates will apply to members in attendance, their families and visiting brethren. In this connection I am instructed by the Local Committee of Arrangements to give our members warning of the fact that in order to secure suitable accommodations, their rooms *must be engaged in advance*. Your Secretary has been in the habit of making an announcement to this effect with exceeding regularity from year to year, and just as regularly no one, or at least only very few, pays the slightest attention to the warning. The necessity of engaging quarters in advance, however, is in this instance very urgent. Now that the old Planters' House has been closed, the Southern and Lindell Hotels often have more business thrust upon them than they are capable of handling, and of late it has been no unusual occurrence for them to deny would-be guests admission, unless their rooms had been previously spoken for. But all of our members can be accommodated without the slightest jar or friction, if they will but take the trouble to address a line to the "Proprietor of the Lindell Hotel, St. Louis, Mo.," telling him the kind and price of room or rooms desired. This should be done at least one week in advance of the first day of the meeting.

In addition to the reduction in transportation rates granted by the Central Traffic Association, the Trunk Line Association has also joined in the movement. As the boundary of the latter Association extends as far east as the western border of the New England States, our Eastern friends will be enabled to avail themselves of the reduced fares.

I am authorized to state that Mr. R. D. Walsh, Chairman of the Local Committee of Arrangements, has kindly consented to take charge of all articles destined for the Gas Exhibit, and will cheerfully surrender a generous portion of his time to the interests of exhibitors. Communications, consignments of gas stoves, apparatus, burners—anything, in fact, intended for the Exhibit—may be directed to Mr. Walsh, in care of the Laclede Gas Light and Coke Company. Exhibitors can rest assured that not only will their wares receive careful handling and be displayed to the best possible advantage, but that they themselves will be accorded the most courteous treatment at the hands of Mr. Walsh and his efficient committee.

The "Paper List" for our Thirteenth Annual will be as follows:

- "Relative Value of Gaseous Fuels," by B. E. Chollar.
- "Effects of Natural Gas Competition," by James Somerville.
- "An Argument in Favor of the Adoption of a Uniform System of Estimating the Cost of Gas in the Holder," by George G. Ramsdell.
- "Impressions of British Gas Works," by George T. Thompson.
- "Mixed Gases," by E. G. Cowdery.

"Wrought Iron, Cast Iron, or Steel—which is the Best Material for Street Mains?" by Eugene Printz.

"What Policy Should the Gas Interest Adopt in Connection with the Approaching World's Fair?" by Walton Clark.

"On the Abuse of the Patent System as Bearing on the Gas Industry, with a Remedy," by Frederic Egner.

"The By-Products of Experience," by Allen R. Foote.

The attention of the Board of Directors is called to the fact that Section I., of Article VII., of our By-Laws reads as follows: "The Board of Directors shall meet as such at least once in each year, on the day preceding the annual meeting of the Association, at which time they shall determine in regard to the propriety of the various papers, drawings, models, or other matters constituting the special order, being laid before the Association." The Board of Directors elected at our last meeting is composed of the following-named gentlemen, who are, therefore, particularly requested to assemble at the Association's headquarters on Tuesday morning, May 20, at 10 o'clock:

J. B. Howard, E. H. Jenkins, Z. T. F. Runner, John Gimper, C. W. Butterworth, E. G. Cowdery, J. S. Ambrose, J. W. Dunbar, and B. E. Chollar.

Application blanks, copies of our By-Laws, and any information not contained in these communications will be cheerfully furnished by
A. W. LITTLETON, Sec'y.

BRIEFLY TOLD.

THE PAPER LIST FOR THE ST. LOUIS CONVENTION.—A glance over the list of papers that are to be presented at the meeting of the Western Gas Association is all that is necessary to force the conviction that the literary part of the proceedings will be more than ordinarily interesting, which is high praise when one bears in mind the always excellent contributions that the Western has been favored with. First on the list comes Mr. Chollar's name, who proposes to deal with the "Relative Value of Gaseous Fuels." Now, it must be admitted that Chollar has a peculiarly attractive method in his penciling, and when the fruit from the latter has been turned out of the basket it cannot be charged with the taint of unsoundness. His subject is one that is in full accord with the thought of to-day, and as he has neither a process to sell nor a pet theory to propel, we can safely count on true independence of opinion from him. Mr. Jas. Somerville will also be welcomed again with heartiness to the arena of disquisition, the records of which bear ample testimony to his carefulness and thoroughness. Next we have Geo. G. Ramsdell, who has in other days—and not so long ago, either—proved his value in the field of argument. His subject, too, is one that bears the charm of novelty. We hoped some time ago that Mr. Thompson would have, through the columns of the JOURNAL, given our readers the benefit of his "Impressions," but, it is without any symptoms whatever of jealousy, that we congratulate the Western on being the first to have an itemized account of the Thompson tour through Europe. If we mistake not, this is Mr. Cowdery's "first appearance" as a paper contributor, and as he is well grounded in his subject, through careful, prolonged and extensive practice at Milwaukee, we confidently look forward to an excellent paper from him. Mr. Eugene Printz will beyond doubt show to good advantage in the matter of determining which is the best iron material for use in street mains, and Mr. Clark will, we imagine, have something original to suggest in his remarks on the correct attitude to be assumed by the gas interest in respect to its connection with the World's Fair. Mr. Egner's name is so familiar to our readers, that no doubt they are at one with us in the knowledge that he could not write uninterestingly, even did he try to so do. Mr. Foote closes, and with seeming appropriateness, a list that is headed by a C(h)ollar. Take it in any light, one cannot avoid the conclusion that the meeting at St. Louis is to be enlivened by an excellent lot of papers on subjects well outside the usual scope, that are to be prepared by authors of unexceptional capacity.

THE GAS APPARATUS EXHIBIT AT ST. LOUIS.—Messrs. Walsh and Egner of St. Louis, are devoting much attention to the matter of arranging for the exhibition of gas appliances that is to form a prominent feature of the Western's meeting. We can only repeat our hope formerly expressed that every one of our advertisers will be represented in the display; and to give the matter as wide publicity as possible, we herewith reprint a circular, dated from the Engineer's office of the Laclede Gas Light Company, on April 29th. The circular reads:

"To Manufacturers of Gas Appliances.—It is the intention of the local Committee of Arrangements of the Western Gas Association to have, in connection with the annual meeting, an exhibition of gas appliances.

Mr. Emerson McMillin, President of the Laclede Gas Light Company, has kindly given the use of the third floor of the large new office building of that Company to the Committee for an exhibition hall. The same is supplied with freight and passenger elevators, gas, water and closets. Exhibitors will be under no expense whatever, except that of sending and removing their exhibits. It is not necessary to remove exhibits as soon as the convention is over. On the contrary, exhibitors may continue to show their goods at the hall to the public or customers, or sell them from the hall, or use the exhibits as samples merely, for an indefinite time, and remove whatever they desire to take away at their leisure and convenience. The hall is located in the center of the business districts of the city of St. Louis—a city of over one-half million of inhabitants; a city as large as New York city of 30 years ago; a city which is the visiting point annually of many thousands of people from Mexico to the Canadas, the Pacific coast and the Gulf. It is not the unimportant border town that many Eastern people who have never been here seem to imagine. This opportunity to exhibit during the convention, and more or less permanently after that time, should not be neglected by manufacturers. Those not represented may regret it when too late. Such as wish to exhibit should address, without delay, the undersigned, and send on their goods, so as to be sure and have them in place on May 20th, next.—Very respectfully, FREDERIC EGNER."

A CORRECTION.—In Mr. B. E. Chollar's paper in the JOURNAL (April 7, p. 485), entitled "Doubts versus Dogmatism," some inexcusable typographical errors occur; and as the admission is made that they are inexcusable, we have but to point them out and correct them. In the eighth paragraph, which is chiefly devoted to an explanation of the diagram accompanying the paper, the words "wave point" occur four times. In each instance these should read "wave front."

NOTES.—We are in receipt of telegraphic advices from Providence, R. I., which are to the effect that the Wakefield Manufacturing Company's "little bill" has been indefinitely postponed by the Rhode Island Senate, and we are glad of it.—There can be little doubt that important changes will soon be perfected in the capitalization and scope of the United Gas Improvement Company. As we understand it the capital is to be increased to \$50,000,000, about 50 per cent. of which is to be held in England. The Company will largely extend its business.—The municipal gas works for Hamilton, Ohio, are virtually completed.—Important plant betterments are being made at the gas and electric lighting stations of the Neenah and Menasha (Wis.) Gas and Electric Light Company.—The Pratt and Ryan Water Gas Construction Company, with a capital of \$100,000, has been incorporated with place of business at Chicago. That is a reconstruction of the old firm of Henry C. Pratt and Co.—The Fresno Republican, of Fresno, Cal., is making a great howl over the imperfect burners maintained in the public lamps, and thinks the Gas Company ought to change them. Why should the authorities not attend to it? It is their duty to do so.—The strike at the Elizabeth (N. J.) gas works was a complete failure. The men were "out" 3 days, and were glad to get back on the old terms.—Mr. Frank Seaverns, of Perkins & Co., will sail for Paris on the 10th inst. No pleasure trip for Frank this time.—The proprietors of the Watkins (N. Y.) Gas Company have reduced the selling rate to \$2.25 per 1,000. Former price, \$2.75.—The San Diego (Cal.) Gas and Electric Light Company has adopted a novel plan to head off competition. Briefly stated the scheme is this: the Company agrees to reduce the price of gas to \$2.50 from \$3.50 per 1,000, provided the consumer will sign a contract to take gas from no other Company for the period of 5 years. The agreement also provides that if during the five years the City Council shall pass, and the Gas Company accept any ordinance by virtue of which the price of gas to all private consumers is reduced below the price named in the agreement, then consumers shall not be required to pay any price in excess of that named in the ordinance, but shall have the benefit of any general reduction in price which may be made.

The Market for Gas Securities.

Consolidated sold above 99½ during the week, and to-day (noon, Friday) is bid for at 99. Prudent observers of the market and careful investors look for 105 before July 1st. Of course, dividend time is approaching, and the shares are carrying the earnings virtually for the old months. Other city shares show no marked change. Brooklyn shares are strong, the highest figures for years being now recorded in one or two of them. Chicago Trusts are up to 51½-52, and Chicago gas, the successor to the Trust, ought to sell at 60 before July 1st. The general market presents no feature of interest, other than that a good demand for shares is certain.

[A Paper read before the Society of Gas Lighting.]

Labor-Saving Appliances for the Manufacture of Coal Gas.

By MR. WM. MOONEY, C. E.

Assuming at the outset that coal will be used for the manufacture of illuminating and fuel gas for many years to come, and that the present methods of purification will also continue in use for some time yet, I venture in this paper to call attention to the use of labor-saving appliances in the handling of the coal, coke and purifying materials.

I am aware of the fact that one not actually engaged in gas making is apt to suggest improvements, so-called, that the practical engineer at first thought may not think of much value; but these notes may encourage thought in the direction, now so earnestly sought, of cheapening the cost of manufacture, and thereby reducing the cost of gas to the consumer, and encouraging him to use it for other purposes than illumination.

The subject treated of in this paper might properly be called the substitution of machinery for hand labor in the manufacture of gas; and the subject may be divided into the following parts:

- 1st.—Handling and storage of coal.
- 2d.—Delivery of the same in the retort house.
- 3d.—Charging and drawing the retorts.
- 4th.—Handling and storage of coke.
- 5th.—Handling of purifying materials—lime and oxide of iron.

That the methods of manufacture used in the manufacture of coal gas are a fit subject for improvement nobody can deny, some of the methods being as old as the business itself.

Improvements, it is true, have been made on certain lines and the cost of manufacture reduced; but these improvements only show more plainly the need of radical changes. For obvious reasons the changes suggested here can apply only to large or medium-sized works.

Handling and Storage of Coal.—Economy in this line has always been a study by engineers and others, and while considerable progress has been made in economical handling and storing, yet there is still room for improvement.

Works that have been badly located, without much thought as to the coal supply, or future growth, thus putting a tax on the manufacture for all time, and saving possibly a trifle in the first cost of the land, can do but little towards economy in the direction indicated above; but improvements, to some extent, can be made almost anywhere.

The inventions of Mr. C. W. Hunt, in apparatus for the handling of coal, have simplified to a wonderful extent the old methods, and the increased amount of coal delivered per man has been as ten to one, with less strain on the laboring man.

The cable system adopted some years ago by the Manhattan Gas Light Company, of New York, and still in use for out-door storage, seems to be simple in its working and a great saving over the old systems.

The only suggestions to be made for improved methods under this heading are the use of link belt elevators and conveyers, which are used with great success in handling anthracite coal. It is probable that gas coals will in time be unloaded from vessels and carried horizontally to the storage piles by means of bucket elevators and conveyers as grain is handled at present.

Delivery of Coal to the Retort House.—This subject is more or less closely allied to the previous one, and in many cases is a part of the same system. At the works of the Newark Gas Light Company the coal is hoisted from the vessel, by the Hunt system, to an elevated hopper, from which it is delivered into cars, from which it is dumped either into bins inside of the retort house, or delivered into the coal sheds through openings in the roof. A platform elevator raises the cars when coal is to be carried from the coal shed to the retort house. Where charging machines are used the coal is also raised in cars on platform elevators. It is possible that, where the coal shed and retort house are properly located, the platform elevator will in time be superseded by the bucket elevator, and the cars will give way to the horizontal conveyer.

Charging and Drawing Retorts.—In this branch of the manufacture of coal gas the whole system is at fault. The horizontal retort is substantially the same as it was at the inception of the business. Whether the lately introduced inclined retort will be a success remains for the future to decide.

The carbonization of coal by the cupola system has never had a fair and thorough test. The many patents covering this system all seem to lie dormant, and perhaps, when some of them have expired, some further experiments may be made in this direction. There are no really formidable obstacles in the way that may not be overcome by patient experiment combined with a liberal expenditure of money.

When coal can be carbonized in cupolas by a continuous process coal gas can be made cheaper than by the intermittent water gas processes. At the same time, the coal gas can be enriched by naphtha or oil without any special apparatus. However, as horizontal retorts are likely to be used for an indefinite time, improvements in the manner of drawing and charging them are still in order.

The stoking machines invented by Capt. A. Q. Ross have taken the lead, in this country at least, and are without doubt, since recent improvements, as perfect machines for the purpose as can be devised. It is hoped that some simple machine may yet be devised which can be made cheap enough to warrant its use by small companies. No suggestions for improvements in this department are made, and probably no changes will be made, except the radical change to the cupola system, as noted above. The many improvements due to the introduction of so-called regenerative furnaces do not properly come within the scope of this paper.

Handling and Storage of Coke.—Much attention has of late been paid to the proper treatment of this valuable by-product, and the sales to private consumers have been increased by proper crushing and screening. The care of the salable coke is of great importance, and there is room for improvement in this direction. The quenching of coke in barrows, while accomplished in one place, is unsuccessful in others, the barrows being most of the time in the repair shop.

Different places seem to require different treatment of coke to make it salable. In one place it must be crushed and screened, while in another it is simply screened by the screening shovels.

At the Milwaukee (Wis.) gas works a system of coke handling has been introduced which seems to be a step in the right direction. The entire product of coke is removed from the retort house cellar entirely by machinery.

The coke falls from the mouthpieces, through the usual apertures in the floor, into conveyers, which travel at a short distance below the iron floor. At the end of the range the coke drops into conveyers of larger size, which carry the coke to the outside of the building, where it is quenched by water from a perforated pipe extending over the conveyer.

By means of a bucket elevator the coke is then elevated and piled, and the only men employed are the engineer who runs the engine, and one man who attends the swivel spout at the top of elevator.

A horizontal conveyer running under the coke pile conveys the coke to another elevator which delivers it to a series of fixed screens, which deliver the different sizes into pockets, from which it is drawn, as wanted, into the delivery carts.

Where four different sizes of coke can be sold or used a revolving screen is found to work well; the coke being crushed in the usual crusher, and the different sizes, viz., broken, screened, pea and breeze, delivered from the screen into separate pockets ready for delivery into carts.

The whole of the coke handling machinery at Milwaukee is moved by a 50-horse engine.

Handling of Purifying Material, Lime and Iron.—Having lately designed a purifying house for a works where they proposed using all means possible for the economical handling of material, a brief description of the same will be given. As a preliminary to making the drawings, a visit was made to one of the most extensive and complete breweries in the city of New York—not, however, for bibulous purposes, but to inspect the manner of handling automatically the materials used in that special business.

It was found that the entire moving of the grain and malt both before and after using was done by machinery. All upward and downward movements are performed by bucket elevators and shoots, and all lateral movements are, with one exception, made with screw conveyers—the exception noted being the spreading of grain on floors to dry, which is done by means of iron buckets travelling on an overhead railway.

It is but natural to suppose that if the materials used in gas works had to be moved to as great a height as the brewers' materials are we should have adopted their methods long ago.

In the purifying house alluded to it was proposed to place the four boxes (which were 24 by 30 by 5 feet deep) in a square in the usual manner, although they were to be operated by a valve system, which would have worked them to advantage placed in line. Directly over the center of each pair of boxes an iron lattice girder was placed, at the proper height to clear the carriages. To the centers of each of these girders were attached the wheels carrying the elevators, which worked inside of an iron enclosure between floor and girder, and a brick enclosure in cellar. The fresh oxide was received at the top into a hopper, and carried to the boxes on each side by screw-conveyers. These conveyers terminated over the center of each box with swivel pipes, by which the material could be spread over the outside surface of box.

The conveyers, which were continuous steel screws, about 12 in. in diameter, were driven by suitable shafting and gearing secured to the girders, and driven by an engine in an adjoining building. The elevator was kept supplied by barrows emptying the revived material into the boot or hopper at bottom. The foul oxide was dropped into the basement, through suitable openings in the bottom of boxes, which were secured by lids with cotter bars and screws, closing them gas tight.

It was proposed to spread the material over the concrete floor of basement by manual labor, using the basement for a revivifying room.

At the East End station of the Cincinnati Gas Light and Coke Company the revivifying floor is located at the end of the purifying room, and the floor is about one foot higher than the top of the boxes. A platform on wheels, running on tracks laid on the floor of purifying room, extends over each box, by means of which the material is brought in barrows and placed in any part of the box.

The foul material is dumped through openings in the bottom of boxes, and is taken up to the revivifying room by platform elevators.

The following suggestions for improved methods may or may not be practicable, but are here given for what value they may have:

The purifying house to have a high and well ventilated and lighted basement, with room for clear passage under the connecting pipes. Directly under each purifier are hoppers to receive the foul material, which is carried by conveyers to belt elevators against the side walls, and thence to the revivifying room, which will be located directly over the purifiers. This room might be suspended from the roof trusses or supported on columns and girders. It would have large openings on all sides filled with louvres, and the roof will have large ventilators. The belt elevator will deliver the foul material into hoppers, from which it can be spread on the floor, by swivel spouts or by manual labor. In the floor of the room there will be openings directly over the center of each purifier, through which the material can be delivered by swivel pipes to all parts of the boxes.

This arrangement may look, at first sight, more extensive and complicated than it really is, and there is no reason why the purifying material cannot be as easily and cheaply handled as brewer's grains.

Another partial improvement, where the basement under the purifiers is used for a revivifying room, and the fresh material raised by platform elevators, may be suggested as follows:

The trays, instead of being supported on bearing bars, to rest on spindles at the corners with dowels and corresponding holes in the trays; the trays to be made smaller than usual. In emptying the box, after breaking down and opening the doors in the bottom, which would be a little larger than usual, the whole contents of the box—oxide, trays and spindles—would be dumped into the room below, the trays and spindles, after cleaning, to be brought up in barrows on the platform elevators.

Bucket elevators and screw conveyers are no new things, both being found in the most ancient grist mills, the primitive screw conveyers being made with wooden pins inserted into a wooden shaft.

The whole outfit of link-belt elevators, horizontal conveyers of different kinds, swivel pipes, and, in fact, the whole apparatus for moving or raising any material, can be obtained and their erection contracted for by well-known establishments, eager to introduce their systems into any new industry.

If any of the suggestions contained in this paper appear to be too radical, it must be remembered that the radical is generally the pioneer or leader (sometimes too far ahead of the times, at which period he is called a crank), but generally not far in advance of the practical man who reaps the crop, the seed of which was sown by his radical predecessor.

Jones' Safety Device for Gas or Air Pipes.

U. S. Letters Patent (No. 424,305) were granted, on March 25, to Edward C. Jones, of Boston, Mass., for "new and useful improvements in safety devices for gas and air pipes." Reproducing the language of the specification, the inventor says:

This invention relates to improvements in safety devices for gas or air pipes; and its object is to prevent explosions of illuminating, producer or heating gases when accidentally mixed with atmospheric air while being conveyed from the gas works to the holder or consumer.

Producer gas for heating purposes, when mixed with a small quantity of atmospheric air, forms a very explosive compound when brought in contact with a light or fire, and when a leak occurs in the pipe a very dangerous accident may happen, causing injury to the pipes or their surroundings if the escaping gas is ignited.

The invention, although particularly designed for preventing explo-

sions in producer gas pipes, is also very well adapted for blast pipes of water gas generators for the purpose of preventing the gas from the generator from backing into the blast air-pipe and exploding the compound gas.

In fact the invention is useful for any and all purposes where there is any danger of explosions from illuminating or heating gases being mixed with atmospheric air in the right proportion for causing an explosion when brought in contact with a fire.

The invention is constructed as follows, reference being had to the accompanying drawings, where—

Fig. 1 represents a vertical section of a valve provided with my improved safety device. Fig. 2 represents an end view of the same, parts of which are shown in section. Fig. 3 represents a modification of the device, showing, in connection with the safety-plug, a cut-off or slide arranged at a right angle to said plug for the purpose of allowing the safety-plug to be cleaned or repaired without shutting off the gas supply from the pipes. Fig. 4 represents a horizontal section on the line XX (shown in Fig. 3). Fig. 5 represents an end view and partial section of a modification, showing a pair of safety plugs arranged side by side within the valve chest for the purpose of substituting one plug for the other in case the plug in use should become foul or clogged up; and Fig. 6 represents a cross section on the line Y Y in Fig. 5.

Similar letters refer to similar parts wherever they occur on the different parts of the drawings.

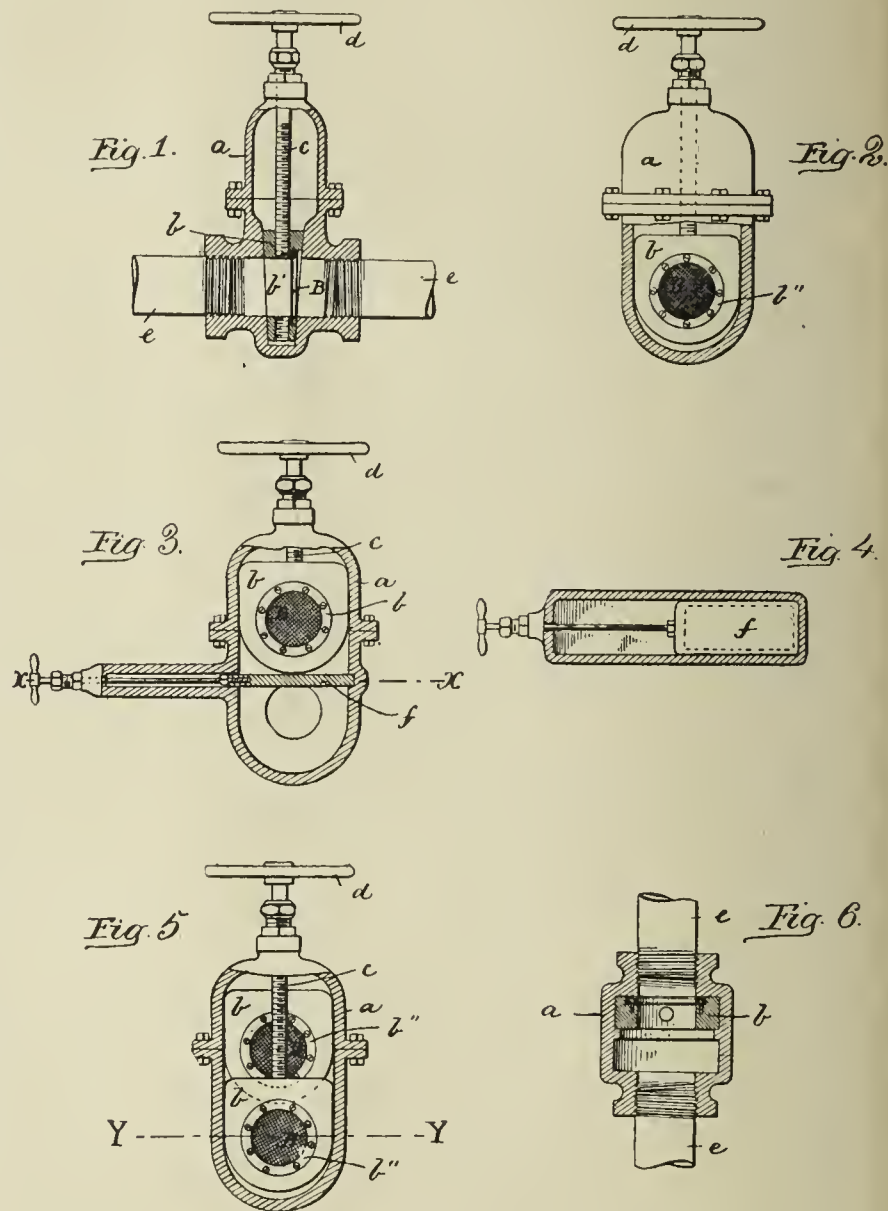

a represents a valve-shell of any well-known form or construction, having on its interior seats against which a vertically sliding plug b is adapted to be lowered by means of a screw shaft c and hand wheel d, and which is also adapted to be raised out of the way, for a purpose hereinafter specified. I do not, however, limit myself to any particular means for lowering and raising the valve, as it will be obvious that other means may be employed. e e represent the gas-supply pipes as usual connected in a suitable manner to the ends or flanges of the valve shell. The plug b has a transverse perforation b', of a size about equal to the interior bore of the pipes e, which perforation coincides with the pipes e e when the plug b is closed against its seat, as shown in Figs. 1 and 2. The said perforation is covered by a fine wire gauze or netting B, which is preferably secured to said plug by means of a ring b'' and suitable fastening screws, as shown in Fig. 2; but this is not essential, as said wire gauze or netting may be secured

to the plug for the purpose of covering its perforations in any other suitable or equivalent manner.

It is well known that wire gauze or netting serves as a means to prevent explosion of gases from passing by such wire screen, and thus it will be seen by the arrangement, as shown and described, an explosion of gas taking place from any cause on one side of the valve and its wire gauze or netting will be prevented from going beyond the latter, thus preventing accidents and damage. Should the wire gauze or netting become foul or clogged with impurities, all that is necessary to do is to raise the plug *b*, so as to establish a free passage for the gas through the valve shell until such time when it may be convenient to shut off the gas pressure for the purpose of cleaning the plug screen or replacing it with a fresh one, as the case may demand.

The modification shown in Figs. 5 and 6 is substantially like the one shown in Figs. 1 and 2, with the difference that in the said Figs. 5 and 6 I have shown the valve shell provided with two plugs of the kind described, instead of one only, as shown in Figs. 1 and 2, each of said plugs being operated independent of the other to enable one to be used at a time, the other one being raised out of position, as shown.

When one plug becomes foul or clogged the other one is forced against its seat and the first one raised out of position, thus enabling the safety device to be used a longer time as compared with the device shown in Figs. 1 and 2, where only one plug and netting is shown.

In Figs. 3 and 4 the device is substantially like that shown in Figs. 1 and 2, with the addition of a solid gate or cut-off *f*, arranged at a right angle to the perforated plug *b*, so as to permit the latter to be raised, when foul or clogged, to the position shown in Fig. 3, after which the horizontal gate *f* is closed, as shown, enabling the operator to remove the top of the valve-shell above the gate *f*, as well as the plug *b*, for the purpose of cleaning the wire gauze or netting *B* without the need of shutting off the gas supply from the pipes *e e*.

Profit Sharing.

In view of the impending labor troubles in this country we are of the opinion that the following, from a paper read by Mr. G. P. Norton before the Liverpool Chartered Accountants' Association, will be read with interest:

Profit sharing will ultimately stand or fall by its own merits, whatever may be our attitude toward it. Amongst the many theories propounded to solve the great labor problem it bids fair at an early date to take a prominent place. The "bonus scheme" of Mr. Livesey at the South Metropolitan gas works has forced it to the front as a prime factor in the controversy. The example of the great London dock strike, combined with the general revival of trade, has awakened the old cry for less work and more wages into such clamorous and persistent energy that just at present more than ordinary efforts are required either to stifle or satisfy. The time-worn dispute seems to be at length resolving itself into a question to what degree it is possible to lessen work and increase wages. Very pertinently Mr. Ruskin's question to the discontented workers comes in: "Do you think the time will ever come for everybody to have *no* work and *all* wages?" It is evident there must be a halting place, and a method of adjustment must be discovered. The problem is undoubtedly one of enormous difficulty, but the time seems ripe for the introduction of any just and effectual scheme.

The rapid progress of the co-operative movement indicates one of the most likely directions in which a permanent settlement will eventually be found; but co-operation leaves the employer out of its plans altogether. For this reason it is not likely to become universal. Account must be taken of the "provision in nature which has made the few strong, wise, and able, and the many weak, foolish, and incompetent." It is desirable, moreover, that those endowed with such superior qualities should have full power to exercise them. The tendency of the English form of co-operation is to reduce all to a dead level—an endeavor after an impossible equality. On the other hand, the employing class has to a large extent forgotten its duties. Instead of regarding trade as a calling, a life's work, what many "want and mean is to make money as fast as possible out of their businesses, and then clear out and turn (so-called) gentlemen." I am afraid this spirit is not altogether absent from the members of our own profession, and the feverish haste to grow rich, at all hazards, has not in a few instances spoiled a promising career and brought about ruin and disgrace.

The co-operative movement could only partially solve the labor problem. Profit sharing between the employer and the employed is closely allied to the principle of co-operation, and in course of time will probably be adopted generally as one of its methods. At present co-operation is an effort of the worker to solve the labor problem in his own way, and chiefly for his own benefit. Profit sharing may become a parallel movement by which the employer will seek to retain the privileges due to mastership, and at the same time secure the goodwill of his work-

people. There is undoubtedly a vast field for the application of profit sharing, providing that it can be shown to be feasible, and an improvement on existing methods. Should it be generally adopted, and there are clear indications of a movement in that direction, the assistance of chartered accountants will be required in a variety of ways. Fortunately a large amount of reliable evidence is available in regard to the experiments already made, which will enable us to judge as to the merits of the various methods under which profit sharing has been worked. It is by no means of modern theory, but rather the outcome of the ancient practice of *product* sharing. In agriculture we find an illustration in the well-known *metayer* system. In the fisheries the "catch," whether good or bad—in many places—has long formed the basis upon which the crew has been paid. In trading ships the sailors have shared the profits of the voyage. In fact, the principle, in different forms, can be traced everywhere, and has been applied to almost every class of undertaking. In course of the development of trade product sharing has, for the most part, fallen into disuse. The division of labor, the difficulty of exchanging the products of labor, and the convenience of payment by a recognized medium of exchange, combined with other causes, have led to the general substitution of the existing wages system. The chief attraction to the worker of payment by wages is that it provides a fixed and certain income, without risk of loss. For this consideration he has forgone his right to participation in profit; and any modification of the system is not likely to succeed, unless this feature is retained. Payment by wages has, however, been tried and found largely wanting, while its particular failings are all absent from the old method of product or profit sharing. In the haste to provide for the exigencies of rapid change and development, the virtue of the old order of things has been lost sight of. Carlyle observes that "The world has been rushing on with such fiery animation to get work, and ever more work, done, it has had no time to think of dividing the wages, and has merely left them to be scrambled for." It is no uncommon thing, however, for old customs to be revived in new shapes, in order to set right prevailing systems which have grown unendurable.

The chief defects of the wages system are that it takes too small account of degree of industry and skill, and it does not offer sufficient inducement for individual effort. "The ordinary employer pays the least he can for labor; and labor, for the most part, gives the least it can in return." Payment by time wages fails notoriously in producing the *quantity* of work of which labor is capable, and the piecework system was introduced to remedy this defect. The remedy, however, produced another evil, for while the quantity was increased the *quality* deteriorated, because of the workers' undue haste and want of care. Quality prizes have been offered and fines for bad work have been imposed, but the difficulty remains; and the expense of supervision is everywhere a subject of complaint. Again, neither piecework nor time wages offers any adequate motive for care and economy in dealing with materials, implements, and machinery. Besides the objections just mentioned, the wages system, as a whole, involves the constant antagonism between employer and employed which finds vent in lockouts and strikes.

Many attempts have been made to perform the work of adjustment with less friction. The sliding scale has been applied, as an automatic regulator, to collieries and mines; but the practical difficulties in the way of working the scale have rendered it, to a large extent, ineffective. Arbitration and the intervention of disinterested parties have done much to make peace, but these remedies ought not to be required. The desideratum, then, it would appear, is a system which will not only remove the antagonism between the employer and the employed, but will make their interests mutual; and so distinctly mutual that the employee shall be able to appreciate the fruits of his extra zeal, skill, carefulness, and economy. The advocates of profit sharing, appealing to the past, as well as to the success of modern experiments, claim that their system answers all requirements. It rewards the worker for his extra exertions, and it gives him a share in the savings effected by his own economy and ingenuity. It is a sliding scale in itself, easily and accurately adjusting the division of fluctuating profits. The claim to these advantages will doubtless be readily allowed, but the manner in which the participation is to be carried out, so as to satisfy both the employer and the employed, requires much consideration.

In the first place, the importance attached by the worker to a fixed and certain payment in wages has already been mentioned; and it is generally agreed that under existing conditions the wages paid should not be less than the regular market rate, the profit sharing being in addition. The next step is to satisfy the employer that his income will not be decreased in order to provide the workers' share of the profits. Now, the strongest argument in favor of profit sharing (assuming that it can be maintained) is that it *creates* the fund which it proposes to distribute,

Mr. Sedley Taylor, in his work on "Profit Sharing," remarks that "the system, far from being a scheme for enriching workmen out of the pockets of the employers, has at its command potential energies capable of opening an entirely new source of profit." That is to say, the zeal of the workmen is aroused, and he puts forth his utmost efforts. There is less waste of time and, therefore, increased production. The cost of superintendence is diminished; for each worker has not only a personal interest in doing his best, but his conduct is under the immediate scrutiny of his fellow-workers, who will lose by his indiligence. The solidarity of interests caused by profit sharing promotes amongst the workers themselves a general surveillance more vigilant and effective than could be obtained from the highest paid overlooker. There is more thrift, more care exercised, and the awakened ingenuity of the worker is brought into full play. Thus, partly earned and partly saved, a fund is raised over and above the ordinary profits, and it is this fund which the worker shares.

An employer contemplating the adoption of the system might be deterred for fear lest, having launched upon a scheme of which he has had no previous experience, he should find it difficult to retrace his steps, if necessary. He may also be reluctant to grant a privilege entailing the possibility of his employees contending for it as a right. The entire control of the whole scheme may, however, be expressly reserved to the employer, with full power either to modify or to discontinue it. The workers' claim to a share in the profits need not receive any legal recognition, and misconduct, or leaving the firm of his own free will, may be made conditions under which his share is wholly forfeited.

The dislike and danger of publicity is another difficulty, but this has been overcome in a very simple manner. The employer privately determines a minimum of profits, after exceeding which he agrees that participation shall commence. This minimum, called a "reserve limit," is revealed to a chartered accountant, who vouches the workers' share. The participation may be regulated by varying percentages (for instance, on the first £1,000 above the "reserved limit" the workers may have, say, 33 per cent., and on the second £1,000, 25 per cent., and so on). It will be necessary for the accountant to have a very clear understanding at the outset, not only of the details of the scheme, but as to the manner of dealing with items in regard to which differences of opinion might be held, as to whether they are chargeable against revenue or capital. The rate chargeable for depreciation, the charge (if any) to be made for proprietor's management, the interest payable upon capital and loans, and the limits within which profits are to be placed to a reserve fund, should especially be settled. In fact every point upon which a conflict of opinion could arise should be guarded by express written instructions. Otherwise it is conceivable, especially where profits are liable to considerable fluctuation, that the accountant's position might often be one of extreme difficulty.

The success of experiments in profit sharing thus far has varied according to the degree of intelligence of the workers. For this and other reasons a partial application and subsequent gradual extension of the principle is often preferable to a full adoption of the system all at once. A nucleus of managers, overlookers, and the *elite* of the workmen being first admitted to participation, the privilege may be extended according to personal merit, length of service, or other qualifications. The *noyau* or nucleus of the *Maison Leclair* has been an important element in the development of that establishment, and the principle wherever adopted has had an educational and moral influence on the remainder of the workers, which has largely contributed to the success of the system.

Another important factor, applicable to joint-stock concerns, is the gradual acquisition by the employees of a portion of the capital of the business. In many establishments a part of the employees' bonus is retained to be applied in the purchase of shares. The celebrated *Familis-tère* of Guise, France, the establishment of M. Godin, retains the whole bonus for this purpose, and further provides that the older workmen shall release their shares to the younger, so that the ownership may remain always in the hands of the actual workers. Where it is possible, shares thus acquired should be inalienable and not subject to be charged for debt, voluntary or otherwise.

The schemes upon which the profits are shared vary widely. Some of the French establishments have most elaborate methods of division; such as would, probably, be wholly unsuited to the ordinary English mind. Only a plain scheme, easily comprehended, even though less effective, would be likely to find ready acceptance in England. The methods of participation may be classified under three general heads. (1) Immediate participation; (2) Deferred participation; (3) Mixed participation. In immediate participation the workers' share is paid in cash.

In deferred participation the share is retained, and either applied towards the purchase of shares in the capital or passed to the credit of a provident, mutual or pension fund. In mixed participation a part of the workers' share is paid in cash, and the remainder is treated as in deferred participation. The basis upon which the profits are divided is determined by the particular circumstances of each case. Important considerations, such as the relative amount of wages paid compared with the volume of trade done, and the degree in which labor is able to exert its influence on the production, render it impossible to conform to any strict rule. After providing for the reserve fund and a fixed rate of interest on capital, the remaining profits are, in the majority of cases, divided in defined proportions between capital, management and labor. The proportion due to each individual worker is usually based on his wages, but the division in some cases is quite arbitrary; the employer allocating the shares according to his own ideas of merit.

The general introduction of profit sharing into Great Britain has undoubtedly been retarded by the abandonment of the experiments made by Messrs. Briggs & Co., at Whitwood Collieries, Normanton, and by Messrs. Fox, Head & Co., at the Newport Ironworks, Middlesborough. The time at my disposal prohibits the narration of the circumstances which led to the adoption and ultimate abandonment of the system by these firms, but their history has been fully dealt with by Mr. Sedley Taylor, Mr. Gilman, and others. Suffice it to say that both attempts were made at times of bitter antagonism between masters and men, and amongst a class of operatives of low average intelligence. Nevertheless, while the system was in force decided advantages were obtained both by the employers and the employed. The scheme was adopted as an antidote to trade unionism, and it failed because of its being placed in deliberate and unwise opposition to labor organizations. The evidence of these cases is rather in favor of the principle of profit sharing than against it, but the fact of the abandonment has certainly produced a distinctly adverse impression. After a long interval the system appears to have received fresh impulse, and during the past few years, and especially in the past few months, several British firms have announced their intention of admitting their employees to participation. A noteworthy example is that of Wm. Thomson & Sons, Limited, woollen manufacturers, Huddersfield. Mr. Geo. Thomson is a disciple of Mr. Ruskin and an enthusiastic supporter of co-operation. He converted his business in 1886 into an industrial partnership, under which, after charging 5 per cent. upon capital and placing 10 per cent. of the profits to a reserve fund until the fund amounts to 10 per cent. of the capital, the employees are entitled to five-ninths of the net profits. The remaining four-ninths may be applied as the Committee of the Society directs, and have actually been distributed to co-operative societies dealing with the concern, by way of bonus on purchases. The workers' bonus is retained and applied in the purchase of shares in the capital of the business. Mr. Thomson has informed me that "the general result has been most satisfactory upon the work and workers, and that a sense of real fraternity pervades the mills." Messrs. Thos. Bushill & Sons, printers and stationers, of Coventry, who are very active in the support of the system, have introduced profit sharing into their business, which is still carried on under a private partnership. A "reserved limit" has been communicated to a chartered accountant, who certifies the sum due to the workpeople in respect of bonus. The amount of profit made by the firm is thus kept secret. Cassell & Co., Limited, the great publishing house, have introduced a system of deferred participation, as well as methods by which their employees may become shareholders in the capital of the Company. Amongst the remaining British profit sharing firms may be mentioned Blundell, Spence & Co., Limited, color and varnish manufacturers, of Hull, and Tangyes, Limited, engineers, Birmingham.

While the instances of successful profit sharing are sufficient to show that it is a practical scheme, and one under which large fortunes can be accumulated, it is only fair to point out that the most marked successes have been achieved by men of exceptional business capacity. Their prosperity has not depended on profit sharing. Nevertheless it is satisfactory to know that men of distinguished ability have chosen this method of attaining their ends. That they have grown rich under the system is a complete answer to the objection that a man who can make a business wants to make it for himself.

Profit sharing does not, like co-operation, tend to cramp individuality. It secures to the industrial "captain" his place as leader, and the rights and emoluments which should accompany that position. The employer may be satisfied under its operation, while the worker, who has always resented his exclusion from the prizes of industry, may be contented also. And again, it can be so worked as to give effect to the principle of "permanent contract," instead of "temporary," between master and man. In removing the causes of discontent it should also do much to

check the impracticable, and often mischievous, scheming of socialists. Profit sharing is not a visionary scheme, it is one of those slow evolutionary processes having its beginning far back in the history of mankind, and it is admitted on all hands to be right in principle. If, however, it effects any practical improvement in the relations between the employer and the employed, it must have a fair chance. The scheme must be employed in cases where the elements of success are present, and not as a last resource to retrieve failing fortunes. To promote its adoption in Great Britain, the example of a few leading commercial men is required—men whose business is not likely to fail, and whose income is such that they can well afford to be generous if need be. To them all the compensating advantages of the system are assured, and from the experience of others there is every reason to expect that from a pecuniary point of view the venture will not prove impolitic. The system should commence amongst the more enlightened of both masters and men, and be allowed to win its way gradually. The employer should be thoroughly informed on profit sharing generally, and his particular plan should be well thought out in all its bearings. Every opportunity and every convenient agency should be utilized for explaining the benefits of the scheme to his employees; and it need hardly be remarked that no occasion is more suitable for enforcing such counsels than when they are accompanied by the tangible illustration of a bonus at the period of stock-taking. If higher motives fail, it is not improbable that the extreme irritation and worry caused by a strike and the fear of its repetition, or the desire to be remembered as a prime mover in a great industrial reform, will bring one of our prominent traders into the field, and we shall then have the scheme thoroughly tested. There is no doubt that numbers would follow a really good start. Amongst our great English traders there are many whose generous spirit has not been entirely buried in the competitive rush of the times. These will readily take up the scheme, provided they are satisfied they will not make fools of themselves, and that its general adoption will be a national benefit. The desire to be masters in the true sense, so admirably described by Mr. Ruskin, will, to all thoughtful and right-minded men, prove more potent than the vain ambition to become members of an unpopular and purposeless plutocracy.

The Waste of Raw Material in Gas Manufacture.

The *London Journal*, in an article on this subject, says that an interesting question arises out of the recent reports that have appeared concerning the working of the various oil and water gas schemes now before the public. It is with regard to the duty rendered from the raw material by different methods of gasifying solid and liquid hydrocarbons; and it will be impossible to treat the present discussions and explanations of these systems as exhaustive unless this question of their respective duty is cleared up by satisfactorily scientific handling on the part of some competent authority. What we mean by the duty of a gasification method is precisely the same as is meant by the same term when used in connection with steam power plant. And, though there is no such absolute datum in gas making as Joule's equivalent supplies to the mechanical engineer, whereby an accurate balance sheet of engine performance with relation to fuel consumption may be prepared, yet it is possible to prosecute analytical investigations of gas making systems on nearly the same lines, and with precisely the same object—to determine the loss by exchange. We know that nature does not give change without charging for the accommodation. When a known weight of coal is put into a steam boiler furnace, which is intended to convert the heating power of the fuel into the mechanical power of the engine, there is a heavy percentage of the potentiality of the coal lost in the process of transformation. Similarly, when a ton of coal is carbonized in gas making retorts, the product is a redistribution of the original atoms in the three states of solid, liquid, and gas, which, if they could all be put into the balance against the coal from which they were derived, would "kick the beam." Theoretically, the arrangement should not entail any loss of weight; but practically there is a loss, although not a very considerable one. In the manufacture of coal gas, a little apparent deficiency (say) in the weight of gas obtained may generally be ascribed to a change in the relative proportions of the other products; but, except within narrow limits, there is no room for increasing the weight of the gas at the expense of any other product. In brief, the amount of preventible waste in practical gas making is not serious, because what does not appear as gas is mostly to be found as coke, tar, and water. The most obvious waste is the carbon deposited in the retorts and hot ascension pipes, which the gas maker usually begrudges as being not only troublesome in itself, but as eminently an example of "matter in the wrong place."

We do not, at the moment of writing, recall any attempt on the part of chemist or gas engineer to determine the exact proportion of waste of the raw material which is capable of being represented as carbon deposited in retorts and pipes. It would not be an easy thing to do with any respectable degree of accuracy, even if the result were worth the labor. There is a certain interest attaching to this question of the proportion of the lost carbon in coal carbonization, however; because it rises into great prominence in connection with the carbonization of oil, which is the next raw material to coal for the manufacture of illuminating gas. All who have ever tried to carbonize oil for gas making in closed retorts, as coal is carbonized, have been confronted sooner or later with the difficulty of the wasted carbon. If oil, whether mineral or vegetable, is run into a retort and gasified, the hot surfaces on and in contact with which the process is effected are speedily coated with a deposit of carbon, which becomes graphitic if the heat is sufficient, and not only represents a serious loss of weight of material, but also prevents the satisfactory continuance of the manufacturing operations. A mineral oil which in a clean, hot retort will commence by yielding (say) 110 cubic feet of 70-candle gas per gallon will, if the process is attempted to be carried on continuously, drop in a very short time to a yield of not more than 60 or 70 per cent. of the first production, while the furnace will fail to keep the retort hot enough to prevent even worse results. If persisted in, the process would eventuate in a retort full of carbon, ranging all the way from graphite where it touched the walls, to loose, greasy soot in the centre. Gasification would have meanwhile altered to the vaporization of a constantly diminishing proportion of the raw oil, until even this would cease. The technical history of oil gas manufacture is a record of attempts to rectify this trouble, which is done in the production of Pintsch's gas by carbonizing the oil in the first stage in a metal tray placed loosely in the retort, and therefore easy to remove and clean. Notwithstanding this device, which is necessary in order that gasification may be conducted continuously in the same plant, the initial loss from deposited carbon, is, of course, constant, and averages nearly one-half of the weight of the raw material. There is a little tar produced when oil is carbonized; but this is the only true residual. The carbon thrown down in the retort is, of course, pure waste; and this waste is so great in the ordinary way of working, notwithstanding all the care that may be used to keep the retorts as clean as possible, that, as already remarked, the gas obtained scarcely weighs half as much as the oil consumed in its production.

Yet, with all its wastefulness, this was the only system of making illuminating gas from common mineral oil before the modern development of water gas was brought to a success by Lowe and his rivals and imitators. This development consists, as everybody knows, in the gasification of oil in immediate contact with the incandescent fuel of a water gas generator, or in a current of the hot gases immediately after these leave the generator. The combination is called illuminating water gas, or more shortly water gas, with the qualification of luminosity left to be understood. Let us, for the purpose of this article, however, regard the resultant gaseous mixture as an oil gas, with its illuminating power diluted, and its bulk correspondingly increased, by the addition of a non-luminous but inflammable cheap diluent. The change of standpoint will give us some fresh ideas on the general subject. From this point of view, then, we see the generator as a means of gasifying mineral oil. If preferred, the water gas can be made in a generator, and afterwards used to dilute oil gas produced in a retort. This was, indeed, the earliest system of water gas working, and the employment of a combustile diluent was a great advance on the crude practice of letting down an unmanageably rich oil gas by an admixture of air. It was evidently a further improvement when the retort was abolished, and the oil gasified upon the same glowing mass of fuel from which the diluent was obtained. If nothing else was gained by the change, the consumption of fuel for heating the retorts and the prime cost of maintenance of this portion of the old plant were saved. Were there any other advantages, however? Was the production of gas from the oil consumed improved in quantity or in quality when the operation of gasification was shifted from the closed retort to the live fuel and hot current of gas from the generator? In other words, does the modern water gas generator return a higher duty, regarded as a mass of gasifying mineral oil, than a Pintsch's retort? This is a point not fully cleared up.

The question possesses practical importance, more particularly in connection with the future of the system of utilizing oil gas in which Mr. E. Tatham (whose process was described in the *Journal* a fortnight ago) is a pioneer. For it will be observed that, although Mr. Tatham proposes to burn his rich oil gas by the aid of oxygen, instead of diluting it with water gas or anything else detrimental to the illuminating

power, he requires to make his gas first. If it is produced in the closed retort, he must submit to the loss incidental to that method of manufacture; but what if the oil is gasified on a bed of live coke? There is no necessity for the simultaneous production of a great bulk of water gas with the oil gas, but only for making just so much as may be required to prevent the oil from being burnt up in the glowing mass of fuel with such stray oxygen as may linger from the blowing up operation. It is quite possible that the duty of a generator used in this way may not be much higher than a closed retort—a suspicion that gains colors from an examination of water gas data. It appears, for example, that 3 gallons of petroleum, weighing about 25 pounds, go to the production of 1,000 cubic feet of 22 candle gas. Now, if this oil were well carbonized in a clean retort, it would make 300 cubic feet of gas rated at about 70-candle power. Increasing the bulk of gas in this way therefore brings down the luminous value pretty much the same as would be the case if the lighting gas and the diluent were separately prepared. It would be satisfactory if Professor Lewes could clear up the doubt surrounding this question, by showing authoritatively how much of the weight of 1,000 cubic feet of Steenberg water gas, as prepared under his supervision for illuminating purposes comes from the oil, which would give the ratio of loss, and how much from the coke, which would also indicate the proportion of fuel lost during the operation of "blowing up," on making producer gas. This would, in short, settle the point, now doubtful, of the comparative efficiency of retort and cupola for gasifying oil.

If it should appear, upon examination, that the wastefulness of a generator for oil is at all commensurate with that of a closed retort, it will go far to establish the deduction that the quickness with which the fluid form of hydrocarbon may be fractionally gasified, has to be paid for by an inevitable waste of carbon, which renders this form less desirable economically than the solid form, although the latter is not so tractable. It would be noteworthy if it should be shown that coal is, after all, the least wasteful form in which a gas making material is obtainable; and, from what can be learned at present, such a conclusion is distinctly probable. Oil may be so low priced in some localities that the unavoidable loss of half its weight in the process of gasification may be commercially insignificant; but the idea would nevertheless remain to irritate engineers, and perhaps to inspire inventors with vain hopes of the possibility of more economical methods.

Life and Efficiency of Electric Arc Light Carbons.

By L. B. MARKS, in *The Crank*.

Ten years ago the electric arc lighting industry in this country was of little commercial importance; but a decade has seen its transformation into one of enormous proportions.

The engineer has devoted himself with assiduity to the perfection of almost every part of the electric light plant: the engine, the dynamo, the lamp mechanism—these have been experimented upon under a variety of conditions, until to-day it may be reasonably doubted that an increase in their efficiency can be more than trivial.

But there is one factor in the system which, as far as the literature on the subject goes, seems to have been relegated to a secondary position, although its prime importance in the production of a perfect light cannot be overestimated. The publication of facts concerning the laws of life and efficiency of arc light carbons has been very limited in extent, and it is the purpose of this article to briefly set forth the results of investigations made in this direction in the laboratory of Cornell University.

The conclusion has been drawn from a multitude of experiments that when the current and difference of potential between the terminals of a lamp are kept constant, with carbons of the same manufacture and type, the *life* of the carbon varies directly as its diameter and inversely as the resistance of the pencil.*

On the other hand, it has been determined† that "the *efficiency* of the carbon varies inversely as the diameter." Hence we see that invariably large efficiency is attained only at a sacrifice of life and vice versa.

Now it is found that carbons which are admirably adapted to one system of electric lighting are very inefficient when burned in another. Those systems which are operated by a small current and a long arc, as the Brush, are technically called *high tension* systems, while those which make use of a large current and a short arc, as the Weston, are known as *low tension* systems.

Recent experiments prove that, generally speaking, a *molded* carbon

is superior for high tension and a *forced* for low. Forced carbons are made by pressing the crude mass through a die of given size, after the fashion of "squirting" lead pipe. But by whatever process of manufacture a carbon pencil is produced, its adaptability to a system depends mainly upon the molecular structure and conductivity of the rod.

Practice shows that "the requirement of the low tension system seems to be a carbon that is hard, and a good conductor, the latter being the more important."* In the high tension system, hardness and low resistances are undesirable. There is a tendency to burn unsteadily and "go out" when a hard pencil is used in this system, and a soft one becomes necessary.

A microscopical examination of the various types of carbons was made, in order to ascertain what relation, if any, exists between the structure of the rod and its efficiency. Transverse sections of the carbons were cut, mounted on glass slides, and viewed through a microscope having a magnifying power of 50 diameters. In each case the enlarged image of the carbon surface was photographed. A complete set of microphotographs was thus obtained, covering the principal types of forced and molded carbons now used in this country.

The study of these photos leads to the assumption that every change in the molecular structure of the carbon is accompanied by a change in the efficiency of the latter. In accordance with this statement a high tension carbon having a more compact structure than another will have a different efficiency. Similarly a low tension pencil in which the particles are symmetrically grouped in parallel ranges, differs in efficiency from one in which the striations are absent. In fact, from the relation found to exist between the structure of a pencil and its action when burned in an arc lamp, it is in many cases possible, by a simple microscopical examination, to *predict* with some degree of accuracy the efficiency of a forced or molded carbon.

The interdependence of efficiency and molecular structure is a subject about which little or nothing has been published. For the present the facts stated above must be taken for granted, as no exact law has yet been formulated. In general, however, it may be said that high efficiency with a low tension carbon is secured by a dense structure, while a loose arrangement of the particles is preferable for a high tension carbon.

It will be seen that because of the more compact structure of the forced pencil its electrical resistance is less than that of the molded rod, and hence, as was stated before, the former is better suited to a low tension system. Yet the manufacture of molded carbon for low tension plants has been and is now carried on to a large extent. Low resistance of the pencil for this purpose is absolutely essential, and although this factor is not attained by virtue of the structure, an approach to the same end is secured by thickly copper-plating the carbons.

On the other hand, in one of the manufactories of this country an attempt is made to decrease the resistance of a molded pencil by submitting the latter to great pressure in the molds. By applying a stress of 6,000 pounds per square inch the requisite density of structure is obtained.

Altering the amount of pitch in the carbon is still another method which is used for regulating the resistance of the pencil.

Summarizing we find that the difference between a high and a low tension carbon may be the result of one or more of four variations in the method of manufacture.

1st.—Variation in the direction of application of stress; e. g. "forcing" and molding.

2d.—Variation in the amount of pressure applied.

3d.—Variation in the "mix" or composition of the pencil.

4th.—Variation in the thickness of the copper coating.

Thus it appears that there is a diversity of means to the same end. The discussion of the methods employed in the manufacture of high and low tension pencils respectively can be found elsewhere.†

We have seen from the microscopical examination of the pencils and the results of actual tests that a slight difference in the molecular structure of the carbon may make a difference of several per cent. in the efficiency.

Hence, though we may fail to find a substance better suited to the purpose than the carbon point, there remains sufficient room for improvement in the manufacture of the latter.

In the foregoing remarks the direction in which this improvement must take place has been pointed out. And it is confidently hoped that in the near future the application of methods to increase the life and efficiency of the carbon will advance the electric arc light one step further towards the attainment of a perfect source of artificial illumination.

* For numerical examples see article "Arc Light Carbon," *The Crank*, p. 9, June, 1889.

† H. Nakano: "Efficiency of the Arc Lamp," *Transactions Am. Inst. Elec. Eng.*, Vol. VI., p. 308.

* G. W. Parker: *Proceedings National Electric Light Association*, Pittsburg Convention, Feb., 1888, p. 455.

† Thesis: "Arc Light Carbons"—L. B. Marks, Manuscript in Cornell University Library.

Notes on the Action of Lubricants.

Prof. J. E. Denton, in the April issue of the *Stevens Indicator*, calls attention to the action of lubricants, as observed by him :

If we "feed" oil to a journal with an ordinary cup, which has its rate of feeding restricted so that the amount of oil supplied to the journal is no greater than is common—say, on a locomotive crank-pin, or in lubricating fast-running shafting, the resistance to rotation produced by friction will be from 3 to 20 per cent. of the force or load to which the rubbing surfaces are subjected. If the rubbing surfaces are in a very smooth condition the 3 per cent. limit is realized, but in proportion as the surfaces are less smooth the friction approximates to the greater limit. The average engine bearing, which is smoothed by natural wear unattended with considerable "end play," may be assumed to create a frictional resistance equal to from 5 to 10 per cent. of the total load on the bearings—that is, the "coefficient of friction" is from 0.05 to 0.10. The idea is somewhat prevalent that modern experiments with oil-testing machines have demonstrated that a journal wears *itself*, if run for a long time without mishap, to such a condition that a coefficient of friction of a fraction of 1 per cent. is finally secured. As a matter of fact the journals of testing machines which have given such a low coefficient have been nursed by long running, under a flood of oil, to an exceptional state of smoothness, attainable only by maintaining a constant "end-play," or reciprocating motion of the brasses over a considerable fraction of the length of the journal. If such bearings are supplied with a restricted amount of oil, and the end-play motion stopped, the coefficient of friction immediately increases from the fraction of 1 per cent. to 3 or 4 per cent. In the case of railroad car bearings there is a natural realization of the low coefficients, because the supply of oil is superabundant, and there is an "end play" motion which gives to the journal and brass a highly polished surface practically unattainable on engine bearings.

Writers on lubrication for a number of years past have apparently assumed that the coefficients of friction of car service were attainable on all journals, and amongst other results of this error has been a general condemnation of the laws of friction given by the eminent scientist of the last half century, General Morin, whose work from a practical standpoint is still worthy of all respect.

Morin experimented* with shafting from about 1½ to 2½ inches in diameter, weighted with heavy pulleys or discs, so as to produce pressure up to about 200 pounds per square inch. The bearing surfaces were of cast iron, the speed about 100 revolutions per minute. The friction was measured with his well-known form of recording dynamometer. Lard oil was used and the method of feeding was made to conform to that used in practical service.

His conclusions were as follows :

Friction during motion is—1st, proportional to pressure; 2d, independent of the area of the surface of contact; 3d, independent of the velocity of motion.

It is the object of this article to show that these simple laws are still realized as nearly as is necessary for the estimation of the friction of practical machinery.

The modern theory of the action of lubricants conceives the frictional resistance to be made up of two parts—viz., a part representing the friction due to metallic contact of infinitesimal irregularities of the bearing surfaces, and a part representing the force to overcome the viscosity or fluid friction of the lubricant itself. The first part is believed to vary in direct proportion to the pressure or load on the bearings. The second part increases very slowly with the pressure. Hence the total friction, which is the sum of the two parts, may increase rapidly with the pressure if the film of lubricant is so thin as to permit considerable metallic contact, or slowly with the pressure, if the supply of lubricant is so superabundant as to practically destroy metallic contact by causing a thicker film of oil to maintain itself between the rubbing surfaces, and thereby make the principal resistance to rubbing simply the force necessary to agitate the particles of oil—i. e., the force due to the viscosity of the oil.

The following tables show experimental results for these two cases. The same figures hold for any oil of about the same viscosity as lard oil. The apparatus used was a small Thurston oil testing machine with a journal 1½ inches in diameter and 1½ inches long. The same brasses were used with both the journals of Table I., but the area of bearing differed slightly.

The results of Table II. apply to both journals of Table I. The rate of feed for Table I. was determined as follows: An ordinary oil cup

having a screwed needle or spindle to adjust the rate of feeding was restricted in its rate of feeding, so that when tightly closed against the atmosphere no oil would run out by gravity, but the slight suction produced by pressing the outlet against the hand and quickly withdrawing it would draw out a drop of oil.

TABLE I.—Friction with Restricted Supply of Lard Oil.

PART I.—Hardened Steel Journal-Composition Brasses.					PART II.—Soft Steel Journal-Composition Brasses.				
Pressures in Pounds		Coefficients of Friction.		Temp. Fahr. Degrees.	Pressures in Pounds.		Coefficients of Friction.		Temp. Fahr. Deg.
Per sq. in.	Total on Bearings.	300 Revs. per Min.	900 Revs. per Min.		Per sq. in.	Total on Bearings.	300 Revs. per Min.	900 Revs. per Min.	
40	88	0.050	0.047	102	13	26	0.070	0.10	100
65	136	0.055	0.050	102	50	100	0.056	0.076	100
115	236	0.054	0.055	102	100	200	0.058	0.075	100
215	436	0.051	0.063	102	200	400	0.060	0.075	100

TABLE II.—Friction with Superabundant Supply of Lard Oil.

Pressures in lbs. Total on Bearings.	Coefficients of Friction.—300 Revs. per Minute.	900 Revs. per Minute.	Temp. Fahr., Degrees.
13	0.060	0.100	100
50	0.038	0.053	100
100	0.032	0.027	100
200	0.045	0.024	100

When the cup was screwed into the upper brass of the machine, the suction,* due to the revolution of the testing journal, would draw out sufficient oil to satisfactorily lubricate the bearings. To produce the superabundant feed for Table II., the adjusting needle was removed from the cups and the latter left open at the top to the atmosphere. Thereby the oil was free to flow to the journal through a hole ¼-inch diameter under two inches of head. The rate of consumption under these circumstances was about a pint per hour. The consumption in the case of Table I. could not be discerned in less than several days' usage. From the inspection of Table I., it is evident that the friction practically follows the laws of Morin, the coefficient being constant for pressures above about 40 pounds per square inch, and so nearly independent of the speed that exceptions to this rule are ascribable to differences of condition of bearing surfaces, and the margin of error in the determinations—about 10 per cent.

A study of Table II., shows. 1st: that while the friction at the light pressures approximates to that given in Table I., for pressures above 40 pounds per square inch, it is considerably less for the superabundant supply; and, 2d, that the friction does not increase proportionally to the pressure, but follows an irregular law evidently depending upon the speed.

Thus, for 300 revolutions the coefficient first decreases and then increases as the pressure changes from 100 to 200 pounds, whereas, at 900 revolutions there is a continued decrease of coefficient. The apparent irregularity is, however, interestingly in accordance with the theory of friction outlined above. Thus, at 13 pounds pressure the coefficient of friction is 50 per cent. greater at 900 revolutions than at 300, because at both speeds sufficient thickness of film is maintained to make the portion of the friction due to viscosity preponderate very largely over that due to metallic contact. The same conditions also apply to the figures at 50 pounds pressure.

But at 100 and 200 pounds pressure, the difference in the suction effect of the two speeds in drawing oil between the rubbing surfaces, evidently makes so much difference in the thickness of the film of oil, that the decrease in friction due to the less degree of metallic contact at high speed, preponderates over the increase of friction due to viscosity. Hence, increase of speed produces exactly the opposite effect upon the coefficient of friction at the higher pressures that it does at the lower pressures. The absolute value of the pressure at which this change of effect takes place would, of course, differ with such variations of proportions and arrangement of journals and feeding orifices as would modify the suction effect due to velocity of rotation.

In practical service the only bearings which receive a supply of oil approximating to that used for Table II., are car journals when freshly supplied with oil and dynamo bearings for which the oil is filtered and repeatedly reapplied.

Steam engine and general machinery lubrication realizes the conditions of Table I.

* This method of adjusting the rate of feeding is common in lubricating shafting and locomotives, etc. The oil is thereby consumed at as slow a rate as is grease, and affords excellent lubrication.

In a succeeding article it will be shown that Morin's laws, if applied to the calculation of the friction of steam engines, afford results in satisfactory agreement with prony brake determinations of this friction.

ITEMS OF INTEREST FROM VARIOUS LOCALITIES.

THE Sioux City (Ia.) Gas Light Company's amended rate schedule became operative on the 1st inst., and cannot fail to produce a marked effect on the sendout. The prices now in force are :

Monthly Consumption.	Net Rate per 1,000.
Under 5,000 cu. ft.	\$1.90
5,000 to 10,000 cu. ft.	1.80
10,000 to 25,000 cu. ft.	1.70

On all gas used for purposes other than illumination, to be registered on a separate meter, the net rate is \$1.50 per 1,000, but all gas bills unpaid 10 days from date of presentation will thereafter be reckoned on the basis of a charge of \$2 per 1,000.

THE franchises and plant of the Decatur (Ala.) Gas Light Company have been sold by the New York Contract Company to Decatur capitalists. The latter have determined to extend the main system to North Decatur.

IN mid-April the employees of the Elizabethtown (N. J.) Gas Light Company notified Superintendent Engel that unless an increase in pay (it figured out something like a 12½ per cent. raise all round) was granted them by April 23d, a strike would be ordered. Manager Kean refused—and properly so—to accede to the modest (?) demands of his force, whereupon the men "went out." The Company had no difficulty in securing the necessary substitutes.

THE Hon. Wilbur F. Lunt, as attorney for the Biddeford and Saco (Me.) Gas Company, has commenced an action against the city authorities of Biddeford to recover \$5,000 damages for injuries to mains and wastage of gas, traceable to the careless operations of the city's street department.

THE following common-sense circular has been issued by the proprietors of the Van Wert (O.) Gas Light Company to the residents of that city :

"Ten years ago gas was first turned into the mains of this Company. During that time there has not been a single night that gas has not been furnished to our patrons. Occasionally the service has not been as perfect as we could desire, but these occasions have been rare, and the causes thereof have been removed, so that we now feel safe in assuring our consumers that the liability for suspended or defective service has been reduced to the minimum. Our business has had a continuous and healthy growth and has never been on a more satisfactory basis than the present time. In view of this fact we have adopted a new discount schedule which will materially reduce the net price of gas on monthly bills of over 1,000 cubic feet. The gross rate of \$2 per 1,000 will be maintained, and all discounts will strictly depend on the prompt payment of bills. All gas passing through any one meter, after May 1st, 1890, will be subject to the following discounts :

Monthly Consumption	Discount, per Ct.	Net Price.
1,000 cu. ft. or less.	10.	\$1.80
1,000 to 3,000 cu. ft.	15.	1.70
3,000 to 5,000 "	20.	1.60
5,000 to 10,000 "	25.	1.50
10,000 and upwards.	(Special.)	

In dealing with several hundred customers it is impossible to make repeated calls in collections. One call will be made at the place of business or residence of each consumer. Bills not then paid must be sent to our office on or before the 10th of the month succeeding the month of consumption, otherwise the gross price will be collected. We urge consumers to frequently read their meters, minute instructions for which are printed on the reverse side of monthly bills. We shall at all times be glad to give any other explanation or information. The meter is the *arbiter* between the Company and the consumer. It is constructed on scientific principles, and is supposed to measure correctly. It is as much the standard of measurement as the merchant's scales ; it is owned by the Gas Company, and is on the premises of the consumer ; neither could tamper with it if he would. Using the best methods and material known to modern gas making, we cannot but feel that we are furnishing a superior article. Should there be any cases of defective service the cause will be found to be local, and we shall desire to be informed of such cases and to be consulted towards proper remedies. We thank our customers for past patronage and assure them of our desire to con-

tinue to serve them well and faithfully. By good service, square dealing, courteous attention and prompt response to complaints, we hope to merit and obtain a large increase of business."

THE Easton (Pa.) Gas Company will soon be out with an announcement of cheaper rates.

THE Davis & Farnum Manufacturing Company have quite a number of contracts on their ledgers, and the probability is that several other plums are about to come their way. Among the list we note the following : An iron roof and ten benches of 6's (complete) for the new retort house of the Lowell (Mass.) Gas Light Company ; a double-lift holder (capacity 200,000 cubic feet) to be put up in Malden for the Malden and Melrose (Mass.) Gas Light Company ; a single-lift holder (capacity 100,000 cu. ft.) for the Gloucester (Mass.) Gas Company ; a tank (35 ft. by 19 ft.) for the Providence (R. I.) Company ; and alterations to the benchwork of the Nassau (Brooklyn, N. Y.) Gas Company. These items, together with their general run of work on water works and sugar houses, including flanged pipe, gas and water pipe, specials, etc., ought to keep Treasurer Farnum and Traveler Davis on the go this summer.

THE following is the summary of the results of the annual meeting of the Chicago Gas Trust Company, held at the Company's office, 101 Lake street, on the afternoon of April 24th. Among the prominent out-of-town stockholders present were Vice-President Benedict, of this city, Chas. F. Dietrich, E. J. Jerzmanowski, P. A. B. Widener and W. L. Elkins ; 206,325 shares out of the 250,000 were represented. Perfect unanimity of thought and expression prevailed, and each vote was unanimous. The supplementary deed of trust transferring the stock of the four Companies in the Trust to the Fidelity Insurance Trust and Safety Deposit Company, of Philadelphia, by the Board of Directors, was ratified, as was also a proposition to change the name of the corporation to that of the Chicago Gas Company. The Directors chosen were : Messrs. W. H. Gebhard, E. C. Benedict, R. M. C. Graham, H. J. Davison, Chas. F. Dieterich, John Sloane, E. J. Jerzmanowski, C. R. Cummings, S. A. Kent, N. K. Fairbank, W. L. Elkins, P. A. B. Widener and C. K. G. Billings. The officers chosen were : President, C. K. G. Billings ; First Vice-President, E. C. Benedict ; Second Vice-President, E. J. Jerzmanowski ; Secretary, T. B. Wells ; Assistant Secretary, C. K. Wooster.

As was intimated in the last issue of the JOURNAL, the Citizens Gas Light Company, of Newark, N. J., has notified its meter setters to remove all meters from stores and residences where the electric light has superseded gas. A general howl along the line is the result ; but it is quite certain that the parties affected will either have to agree to burn a certain quantity of gas per month, or else pay a meter rental.

THE Girard (Kansas) Gas and Electric Company has been incorporated by O. T. Boaz, J. A. Bendure, J. T. Leonard, S. P. Christian and Austin Hawley. It is capitalized in \$25,000. This place is the capital of Crawford county, Kansas, and is on the Missouri River, Fort Scott & Gulf Railroad, at a point 26 miles south by west of Fort Scott. It is also connected by rail with Joplin, Mo. Coal of fairly good quality is mined there. Population, about 6,200.

THE American Gas and Ventilating Machine Company, with principal offices at Auburn, Me., has been incorporated with a capital of \$500,000. The business to be prosecuted is the manufacture of machines for compressing air and generating gas. Its officers are : President, Geo. H. Barrows, of Somerville, Mass. ; Treasurer, Wm. P. Hammond, Charlestown, Mass.

ON and after May 1st the offices of the St. Paul (Minn.) Gas Light Company will be in the handsome building of the New York Life Insurance Company, corner 6th and Minnesota streets, that city.

THERE was a lively contest this year at Paducah, Ky., for the public lighting of that city, which is not to be wondered at when it is remembered that the successful bidder would have the work until 1894. The bidders included the Thomson-Houston Electric Arc and Incandescent Company, the Excelsior Electric Company (arc), the Ohio Gasoline Street Lighting Company, and the Paducah Gas Light and Coke Company. Mr. H. W. Meyers, Superintendent of the latter Company, seems to have convinced the Council that gas was not only the light of the present, but was to remain the light of the future—for four years at any rate—for his Company was awarded the contract to maintain 300 gas lamps (5-ft. burners), moon schedule, on the basis of a gas rate of \$1.25 per 1,000 cubic feet. Twelve of the City Fathers were present, and 11

of them voted for gas. The Paducah Company's rates are : For public uses, \$1.25 per 1,000 ; for illuminating (private) purposes, \$1.75 ; for cooking, heating, and power uses, \$1.50. Supt. Meyers will put down 3 miles of new street mains this season. He is a good one.

WE are in receipt of a handsomely printed circular sheet containing the names of no less than 112 housekeepers of East Saginaw, Mich., who are using either gas stoves, ranges, fires, etc., furnished by the Gas Company of that city. This of itself would look "numerous enough" to fully testify to the fact that gas as a cooking and heating agent is away above par in the locality noted. Supt. G. A. Hyde, Jr., however, to whom we suppose the credit of compiling such an effective advertising method is due, clinches this testimony in the remark that the list is but a partial one. Well, he ought to have success ; for it took some courage to put the cooking and heating gas rate in a place like East Saginaw at \$1 per 1,000. He is a son of his father, and no mistake.

SOME days ago the Wabash Railway Company entertained by invitation a select party, for the purpose of showing its guests how well the Pintsch system of compressed gas lighting answered for the ordinary illumination of a swiftly moving train. The trial train was made up of 5 coaches, and the trial trip covered 50 miles. The affair was most successful.

AT the annual meeting of the Ottawa (Can.) Gas Company the financial reports rendered were indorsed as satisfactory by the shareholders. The officers chosen were : Directors, Robt. Blackburn, Senator Clemow, S. Howell, Thos. Patterson, Jas. McLaren, and Allan Gilmour. President, Robt. Blackburn ; Managing Director, Senator Clemow ; Secretary and Treasurer, Alex. Spittall.

AT a meeting of the Board of Directors of the Charleston (W. Va.) Gas Light Company, it was ordered that the President (Mr. Frank Woodman) of the Company be authorized and directed to take immediate steps to erect an electric light plant, for arc and incandescent lighting, under the authority conferred by the charter of the Company, of such capacity as he may upon investigation approve ; and to advertise for bids for same.

SOME time ago we noted the formation of a gas company for Fort Benton, Mich., to which we may add that the concern bears the title of the Excelsior Gas Company. The proprietors have determined to install a water gas plant, which will be completed and put in operation as soon as possible.

MRS. ANNIE RILEY, through Messrs. Doherty & Doherty, has taken an action, *in forma pauperis*, for \$5,000 damages against the Montreal Gas Company. The declaration states that plaintiff's husband, John Riley, who was a stoker in defendant's employ, when coming out of the workshops, at an early hour in the morning, fell into an excavation in the yard and sustained injuries that eventuated in his death.

THE people of Windsor, Ont., are to vote on a proposition empowering the local authorities to invest \$15,000 in an electric lighting plant, to be operated on municipal account.

MR. JNO. CABOT'S specialtes in trays for gas works still hold the market. The Church grooved slat tray for iron oxide is a great success.

THE proprietors of the Joplin (Mo.) Gas and Coke Company are out with an announcement of cheaper gas, the concession to affect all gas consumed from first inst. Under its terms the gross rate is cut from \$2.50 to \$2 per 1,000, and prompt payment—*i. e.*, accounts must be settled 8 days from presentation—secures the following rebates :

Monthly Consumption.	Discount per Cent.	Net per 1,000.
Under 5,000 cu. ft.	5 "	\$1.90.
5,000 to 7,500 cu. ft.	10 "	1.80.
7,500 to 10,000 cu. ft.	15 "	1.70.
10,000 and over	20 "	1.60.

Where a separate meter is placed for the registration of fuel gas, a net rate of \$1.50 per 1,000, irrespective of monthly consumption quantity, is operative ; but a meter rental of 25 cents per month is charged. This latter item seems to us to be in line with imperfect policy, and we hold to the opinion that the consumers would be better satisfied were they called on to pay the \$1.60 per 1,000, without the rental feature. The company maintains a handsome assortment of cooking and heating appliances, which it disposes of at net cost. One excellent feature of the Joplin cheap gas announcement is, that it is made to take up about one-quarter page of one of the local dailies ; and it is printed in such

a bold manner that one is led to exclaim, "Well, the Joplinite who cannot read that while in motion, must be a very swift runner."

THE case of Roland H. Smith *vs.* the Pittsburgh Gas Company, was decided about a fortnight ago, in an opinion filed by Judge Acheson, who upholds defendant. In general terms the suit was for infringement of letters patent (granted November 17, 1885, to Smith,) for a process of producing illuminating gas. Judge Acheson's opinion, which is a very lengthy one, goes into the merits of the case with great minuteness, and the summing up is as follows : "I do not see how it can be denied that the process practiced at Beaver Falls was the same as that described in the Smith patent, and was an anticipation. What more does the patent disclose than was there known and prosecuted? As to the proper proportions in the admixture of the natural gas and the fluid hydrocarbon the patent is silent. It gives no instance whereby the excessive employment of the enriching agent may be avoided. Nor can the transaction at Beaver Falls be deemed an unsuccessful and abandoned experiment within the meaning of the patent law. An illuminating compressed gas was there actually produced, and for a long time was extensively used. The cessation of the use was not because the product was impracticable, but by reason of the unsatisfactory nature of the product, in that the compressed gas burned with a smoky flame. And here it must be observed that there is testimony in the case tending very strongly to show that smokiness is a defect inherent in gas produced by combining natural gas and petroleum gas, for the reason that natural gas is deficient in hydrogen. I will not, however, discuss that subject. It is enough here to say that in my opinion the defence of anticipation has been made out."

THE Kentucky State Senate has granted the Louisville Gas Company the right to manufacture and distribute electrical currents for lighting and power purposes. We might also note that the Senate Committee, appointed to investigate the charges of corrupt interference by the Company in municipal and State elections, was, upon request of its Chairman, Senator Poyntz, discharged from further service in that direction. Thus ends the investigation farce, which termination might lead one to exclaim : "What were they (the Committee) born for, when they were so soon done for?"

THE proprietors of the Inter-State (St. Louis, Mo.) Gas and Water Works Company have agreed to include the "erection, management and maintenance of electric light plants" in the objects for which the Company was originally chartered to uphold.

THE Village Trustees of Glens Falls, N. Y., have awarded a 3-year contract for the public lighting of that place to the Glens Falls Electric Light and Power Company, at its bid rate of 26 cents per arc per night, on an all-night schedule. Much dissatisfaction exists over this determination, because another and lower bid for the service, from the Glens Falls Gas Light Company, was entirely disregarded. The contract for the naphtha lighting was awarded to the New York and New Jersey Globe Gas Light Company at its bid of 7 cents per lamp per night.

THE Committee on Manufactures, of the Massachusetts Legislature, have presented a report in the matter of their investigations at Alexandria and Richmond, Va., and Philadelphia, as to the operation of gas and electric lighting plants by municipalities. The Committee considered it inadvisable to recommend the adoption of municipal control of gas and electric light works in the cities and towns of Massachusetts. In Richmond, they say, it is evident that a limited number of citizens are paying a high price for gas without corresponding advantages to the city. As to Philadelphia, they say, if the offer of \$1,200,000 rental and 17,000 street lights free had been accepted, the city would certainly get its gas as cheaply as it does now, and instead of an actual loss of \$104,145, would have an actual profit of \$1,851,000.

It is said that the Fahneltjelm Incandescent Gas Light Company will attempt to secure a fuel gas charter for Rockford, Ills.

THE sales of gas at Atlantic City, N. J., during the month of March amounted to 3,000,000 cubic feet, which is an increase of about 25 per cent. over the quantity consumed in March, 1889.

MR. ALEX. L. MCKAIG, of the Fuel Gas and Electric Engineering Company, of Pittsburgh, Pa., is to be married to a Miss Rogers, of London, England. The ceremony will take place in June.

MR. H. P. TALMAGE, of Netherwood, a suburb of Plainfield, N. J., has been lighting his mansion on Belvidere avenue with gas produced

from some type or another of an automatic gas machine. He will probably resort to other means of obtaining artificial illumination, as the apparatus "exploded, with a loud report," on the evening of Sunday, April 20.

SUPT. EVANS, of the Spencer (Mass.) Gas Company, is using Lima crude oil for enriching purposes.

IN a recent issue of a St. Louis newspaper we find the following: "Gas bills to private consumers for the month of April," said Mr. J. D. Thompson, Vice-President of the Laclede Gas Light Company, "will be made out at \$1.25 per 1,000 cubic feet. It will be time enough to reduce the rate to 90 cents when the court of last resort decides that we must do so. The Carondelet Company will probably charge what it has been charging right along, \$2 per 1,000. The Carondelet Company is not a large one, and the bulk of its business, probably, is in the supply of gas to the public lamps."

IN respect to the petition of the Laclede Company for an injunction restraining the city of St. Louis from attempting to enforce the provisions of the 90 cent gas ordinance, we have the following advices: The Laclede Gas Light Company has anticipated the city in the litigation to test the validity of the new gas ordinance fixing the price of gas at 90 cents per 1,000 cubic feet, and which went into effect on March 10 last, by commencing an injunction suit in the Circuit Court to restrain the city from enforcing the new ordinance. The Gas Company, with Gibson, Bond & Gibson, Boyle, Adams & McKeighan, and Lubke & Muench as attorneys, filed a petition in the Circuit Court about a fortnight ago, asking the court to declare the ordinance invalid and of no effect, so far as the Laclede Company is concerned, and to enjoin the city from attempting to enforce it. The petition sets out the incorporation of the Laclede Gas Light Company by the General Assembly of the State of Missouri, by an Act approved March 2, 1857, and an amendatory Act approved March 26, 1868; that the Company under the grants thus given it has laid 135 miles of pipe, has a large and valuable plant, and has been supplying gas to consumers, and that this right is in no manner dependent upon or subject either in respect to the right of vending gas or the price at which it shall be vended, or in the manner of collecting its bills for gas consumed, to any control, legislation, supervision or dictation on the part of the city or any of its officers, agencies or instrumentalities.

It is then stated that on January 1 last there was existing in St. Louis a corporation known as the St. Louis Gas Light Company, the incorporation of which is set out in detail, which corporation expired by limitation on the date last named; that said Company had a contract with the city to supply gas to consumers at not less than \$3.25 per 1,000 cubic feet, and to light public lamps, etc.; that on January 30, 1886, while said contract was in force, the city desiring a modification thereof to the extent of a reduction in the price of gas, after certain negotiations, adopted an ordinance, which was approved by the Mayor reducing the price of gas to \$1.25 per 1,000 cubic feet to consumers, and a reduction in the price to public lamps, and extending the franchise of the St. Louis Gas Company for 30 years from Jan. 1, 1890, which ordinance the St. Louis Gas Company duly accepted, and executed a bond in the sum of \$100,000 to the city, as required by its provisions, to abide by its conditions, which conditions caused the Company to surrender \$1,574,244 in the form of reductions to consumers, and \$116,000 by way of rebate for public lamps, between the time of the extended franchise and January 1, 1890. The sale of the St. Louis Gas Company to the Laclede Gas Company on December 24, 1889, is then set out. It is then asserted that in purchasing said Company the Laclede Company succeeded in all the rights, privileges and franchises of the St. Louis Gas Company, including the conditions in the ordinance extending the franchise of the St. Louis Gas Company; and the city was obligated in like good faith to perform all the obligations of the ordinance.

It is then alleged that the city is attempting to evade the obligation of this ordinance, and in February last passed an ordinance attempting to fix the price of gas to consumers at 90 cents per 1,000 cubic feet for illuminating gas, and 45 cents per 1,000 cubic feet for fuel and power purposes; that in passing said ordinance the Municipal Assembly did not hear evidence or investigate or consider judicially the question of the reasonableness of the price of gas, but determined the same arbitrarily and finally without notice to the plaintiff; that this notice is in effect an attempt to deprive plaintiff of its franchise and property without due process of law, and that the attempt to impose a fine of \$250 for violating the provisions of the ordinance is a violation of article 8 of the Consti-

tion of the United States, and article 2 of the Constitution of the State of Missouri.

The matter was presented to Judge Valliant, who granted a temporary injunction restraining the city until the 29th inst., at 2 o'clock P. M., from interfering with the Gas Company or its property in any manner. At that date, if the pleadings are perfected, the case will probably be heard upon its merits. The case, succinctly stated, is nothing more than a modified revival of the old tripartite contract litigation so disastrous to the city in times past. The ordinance granting an extension of the franchise of the St. Louis Gas Light Company was nothing more than a modification of that contract.

THE Providence (R. I.) Gas Company will maintain 15 additional public lamp posts in the village of Auburn.

MR. SHELTON, of the United Gas Improvement Company, Philadelphia, is designing a plan for an auxiliary water gas plant for the Pittsfield (Mass.) Gas Company. The capacity desired is 150,000 cubic feet per diem.

ON and after July 1st the price of gas in Lynn, Mass., is to rule at \$1.60 per 1,000 cubic feet. The present rate is \$1.80. That the Company is progressive is shown in the following table of rate reductions for the last decade:

Date.	Rates.
Jan. 1, 1881, from.....	\$3.00 to \$2.50
July 1, 1884, "	2.50 to 2.00
Oct. 1, 1886, "	2.00 to 1.80
July 1, 1890, "	1.80 to 1.60

AT an adjourned Council hearing in the matter of the petition of certain parties who seek the right to operate the Citizens Gas Company, in the town of Marlboro, Mass., much interesting testimony was volunteered. We give the following summary of the proceedings:

Messrs. E. L. Bigelow, W. N. Davenport, and C. F. Morse appeared for the petitioners. J. W. McDonald, Esq., in behalf of the Marlboro Gas Light Company, remonstrated against granting. The petitioners gave as their reasons for the request that they wanted cheaper gas, and also wanted the present gas works removed so far away that they would not be offensive to the denizens of Main street. Mr. Bigelow stated they had made inquiries where water gas had been used, and found it worked well both for heating and illuminating purposes. He said it could be furnished for from \$1 to \$1.50 per thousand, which would be quite a saving from the present price charged in town. Mr. Bigelow said that on pure business principles he wished to procure gas at a less price, and also furnish it to others at less cost. Mr. McDonald asked if the Company had been chartered. Answer, yes. Mr. Davenport exhibited the charter, which had ten signatures, with a capital stock of \$50,000. In answer to the question if the stock had been paid in, he replied no; no money had been paid out except the expense of procuring the charter. The reply to the question if the Company had a certificate for doing business was that permission had not been granted yet by the Gas Commissioners. Mr. McDonald asked what processes they proposed to adopt in making gas. If the old Company would furnish it as cheaply, would the new Company still insist on their petition? Would the new Company be satisfied if the old Company removed their plant farther from the Main street? Do you propose laying mains in the same streets occupied by the old Company and compete for the same patronage? Don't you think with so many pipes in the ground, and sewage soon to be put in, that it would make too many? The answer to the first was that substantially the same processes would be adopted as the old, though the manufacture of water gas might be introduced if feasible. Several places were cited where it had been used with good results. The second and third questions were answered by Mr. Morse that they should still insist on their petition. The fourth question was answered in the affirmative. The answer to the fifth query was in the negative. The petitioners stated one thing contemplated was the furnishing of fuel gas. The petitioners said they would furnish same guarantee as the old Company. They thought competition would give cheaper gas and not give so much chance for a corporation to monopolize the price as with one company. Mr. McDonald asked what the petitioners knew about the manufacture of gas and the expense, from a practical standpoint, and their reply showed little knowledge in that respect, only what they had gained by talking with individuals. The petitioners said they would produce a man thoroughly acquainted with the manufacture of water gas if the Board desired. By request of Mr. McDonald the hearing was adjourned.

Steel-Melting by Water Gas.

A contemporary states that under the auspices of the British Water Gas Syndicate, Limited, experiments in steel melting by water gas were conducted at the Leeds Forge recently, in presence of a number of gentlemen interested in steel melting. The object of the experiment was to prove the utility in the way of economy of time required to melt an ordinary charge of pig iron into Siemens steel by means of water gas mixed with producer gas, as against the older practice of using merely producer or Siemens gas; and also in the economy of fuel required for the purpose. It was stated that under the old-fashioned system the Leeds Forge had only been able by one furnace to produce from 9 to 11 charges per week, with a consumption of fuel of about 10 cwt. to the ton of ingots produced. Experiments have been going on for some time; and on March 20, for instance, work was conducted at a speed of from 20 to 22 charges per week, with a consumption of less than 5 cwt. of fuel per ton of ingots produced, and similar or even better results were expected from the experiments on March 21. At this establishment similar apparatus to that here employed is being made for several firms in different parts of England. The system is said to have been adopted with success on the continent. For instance, the Hørde Steel Works Company, in Westphalia, are converting all their steel by means of water gas, and are also heating large armor plates with it, and puddling iron in six puddling furnaces. They are also said to be melting pot steel in large furnaces, where 48 crucibles of steel are operated upon with water gas at the same time. The largely increased output of puddling iron may be gathered from the fact that whereas under the old system the output per man per shift was 14 cwt. in England, at Hørde, where water gas is used almost exclusively, the quantity turned out per man per shift is 40 cwt. Besides, the product is said to be superior, owing to the high melting point at which water gas does its work. The practical men present at the experiments were afforded every opportunity for obtaining samples of the gases going into and issuing from the furnace, and of the materials used in the charge, and of the charge at the various periods of its conversion into steel; so that by analysis they might be able to form their independent judgment as to the improved action which takes place under the influence of water gas. The charge, consisting of 9 tons 6 cwt., was completely converted into mild steel within the space of 5 hours 4 minutes, and when tapped it was to all appearances in a more fluid and better condition than that usually obtained under ordinary producer gas. The gentlemen present were satisfied at this practical demonstration both as to facts and figures on a large scale of the application of water gas for this special purpose.

With regard to the above described experiments a correspondent to the *Iron and Steel Trades Review* writes as follows:

From the notices of the experiments made at the Leeds Forge, in melting steel with water gas, which have appeared in last week's technical journals, it may be inferred that the steel was made on the open hearth of a Siemens furnace (with four regenerators), and that the fuel employed was a mixture of producer and water gas. A charge was made, it appears, in 5 hours with a consumption of fuel equivalent to 5 cwt. per ton of steel produced.

These figures are very interesting to steel makers, but it would be well if they could be supplemented by information on the following points, viz.: whether the water gas employed was mixed with gas from a Siemens producer, or with the gas sometimes called producer gas, which is made in the water gas apparatus; also whether the consumption given as five cwt., represents the fuel consumed in the production of water gas, or of producer gas, or of both combined.

No one will doubt that gas made in the Siemens producer may be enriched by the addition of water gas (hydrogen and carbonic oxide free from nitrogen), and that by using such enriched gas in the Siemens furnace a higher temperature may be obtained than by using producer gas alone; but it may be questioned whether this can be done profitably, both as regards cost of fuel and wear and tear of furnaces.

With regard to the melting of a charge in five hours at the Leeds Forge, in the Siemens crucible steel melting furnace, which was introduced about 1867, five to six charges have always been made per 24 hours in regular work; and if similar materials, viz., pig iron and puddled bar or scrap, be used in an open-hearth furnace, steel should be melted as quickly in one case as in the other, and this, indeed, has been reported from the Continent. If the puddled bar is charged red hot, the working should be even more rapid, as in pot furnaces cold materials are exclusively employed. The notices concerning the use of water gas at the Leeds Forge refer to the fusion of pig iron and scrap, and it follows from what has been said that there is no evidence of improvement by the use of water gas, as, of course, the melting of steel in crucibles, and on the open hearth, to which reference has been made, is effected with gas from the ordinary Siemens producers.

The statement that the normal production of puddled iron in an

ordinary puddling furnace is as low as 14 cwt. per shift can only be looked upon as a clerical error, inasmuch as 32 cwt. per shift is the usual figure for a forge mixture, and the consumption of fuel 25 cwt. per ton of puddled bar, as may be found in the standard works on iron and steel of Percy or Bauermann. A return which I have seen from the Pather Works, Glasgow, of the day and night shifts on the 24th of last month confirm these figures, the production of bar iron from an ordinary puddling furnace being given as 32 cwt. per shift, and the consumption of fuel 23 cwt. per ton of puddled bar. At the same works a double Siemens furnace of the new type has lately been set on work for puddling iron, and the production is returned as 34 tons of puddled bar per shift, which is fully equal to the ordinary furnace, while the consumption of fuel is reduced to 1 cwt. per ton for puddled iron. It would be interesting to learn the consumption of fuel in puddling with water gas.

Discharge of Steam through Orifices.

The *Engineering Record* says that while the question of steam discharge through orifices has been ably investigated from a theoretical standpoint, there is a lamentable deficiency of experimental data on the subject. The following table, calculated for steam pressures ranging from 10 to 150 pounds per square inch above the atmosphere, will therefore prove valuable. It has been calculated by means of a formula given in a Report on Safety Valves in the Transactions of the Institution of Engineers and Shipbuilders in Scotland, and stated to agree with the results of experiments for pressures not lower than 10 pounds per square inch with a surprising degree of exactness:

Velocity of Efflux of Steam into the Atmosphere.

Gauge Pressure.	Velocity of Discharge in Feet per Second.	Pounds of Steam Discharged per Minute per Sq. In. of Opening.	Gauge Pressure.	Velocity of Discharge in Feet per Second.	Pounds of Steam Discharged per Minute per Sq. In. of Opening.
10	861	22.2	70	894	73.5
15	867	26.6	75	895	77.6
20	871	30.9	80	896	81.9
25	874	35.3	85	898	86.0
30	877	39.5	90	899	90.3
35	880	43.8	95	900	94.4
40	882	48.0	100	902	98.6
45	884	52.3	110	904	106.9
50	886	56.5	120	906	115.2
55	888	60.7	130	908	123.5
60	890	65.0	140	910	131.9
65	892	69.3	150	912	140.2

For obvious reasons no table can be calculated for the flow of steam through pipes since the element of pipe length there must be considered, and no two cases in practice would have the same length of pipe. In Robert Briggs' "American Practice in Warming Buildings by Steam," however, extensive tables are given for different conditions, to which it may be interesting to refer.

An Ingenious Device for Lighting the Bottom of the Sea.

In the investigations that were undertaken by the Prince of Monaco in deep sea soundings, an ingenious method was adopted to obtain specimens of the living creatures existing at the bottom of the ocean. The apparatus used was shown at the Paris exhibition. The cage in which the submarine animals were caught, according to *Le Genie Civil*, consisted of a cylinder of wire having three conical entrances, like those of a lobster pot, and weighted for submersion with detachable weights. It was, however, very unlikely that at these immense depths, where the darkness is practically total, any fish would voluntarily find their way into the trap, and steps were taken to attract them by a light placed inside it. Obviously, no light was available but an electric light, but to get an electric light to burn a mile or two under water was not easy.

The only resource was to supply the incandescent wire from a battery in the trap. Here, however, another difficulty occurred. It was necessary to enclose the battery, which had to be of considerable power, in a box of some kind, and as the hydrostatic pressure at such depths was six or seven hundred pounds to the square inch, it was found impossible to make a box which was not crushed before it reached its destination. At last, however, this trouble was overcome by the curious device of connecting the box with a balloon. The balloon was made of cloth dipped in indiarubber, and so arranged that the air in it was in communication with that in the battery box.

On sinking the apparatus, the hydrostatic pressure, being virtually uniform all round the balloon, compressed it equally on all sides, forcing the air out of it into the battery box, until the pressure inside the box and balloon exactly balanced the pressure outside. This process went on to any extent, so that at the bottom of the sea, although the balloon was reduced by the enormous force exerted on it to a small fraction of its original size, it still kept the internal and external pressure equal. On raising the apparatus again it expanded as the pressure diminished, and brought the battery box to the surface uninjured. So successful was this device that, not content with capturing deep-sea fish, the prince and his assistants propose on their next expedition to send down a photographic apparatus and bring back negatives of the bottom of the ocean, as seen by the electric light.



A. M. CALLENDER & CO., PROPRIETORS.

EDITOR—Jos. R. Thomas, C.E. ASST. EDITOR—T. J. Cunningham. MANAGER—C. E. Sanderson.

PUBLISHED ON EACH MONDAY OF THE YEAR AT No. 42 Pine Street, New York.

This is a recognized official organ of LIGHT, HEAT, STEAM, WATER SUPPLY, VENTILATION, SANITARY IMPROVEMENT, AND GENERAL SCIENCE

TERMS: SUBSCRIPTION—Three Dollars per annum, in advance. Single copies, 10 cents.

AGENTS. NEW YORK.—AMERICAN NEWS CO., 39 and 41 Chambers Street. PHILADELPHIA.—PRATT & CO., Corner Ninth and Arch Streets. Germany.—B. WESTERMANN & CO., of New York.

MONDAY, MAY 5, 1890.

Gas Stocks.

Quotations by Geo. W. Close, Broker and Dealer in Gas Stocks.

16 WALL ST., NEW YORK CITY.

MAY 5.

All communications will receive particular attention. The following quotations are based on the par value of \$100 per share.

Table of Gas Stocks with columns for Company Name, Capital, Par, Bid, and Asked prices.

Out of Town Gas Companies.

Table listing various gas companies and their financial details, including Boston United Gas Co., Bay State Gas Co., Buffalo Mutual, etc.

Advertisers Index.

Table listing advertisers and their page numbers, categorized by Gas Engineers, Gas Works Apparatus and Construction, Gas and Water Pipes, Processes, Inclined Retorts, etc.

GASHOLDER TANKS.

Table listing gas holder tanks and their locations, such as W. C. Whyte, New York City.

GASHOLDER PAINT.

Table listing gas holder paint products, such as The Government Waterproof Paint Co.

RETORTS AND FIREBRICK.

Table listing retorts and firebrick products and manufacturers, such as J. H. Gautier & Co., Jersey City.

SCRUBBERS AND CONDENSERS.

Table listing scrubbers and condensers, such as G. Shepard Page, New York City.

REGENERATIVE FURNACES.

Table listing regenerative furnaces, such as Bartlett, Hayward & Co., Baltimore, Md.

GAS GOVERNORS.

Table listing gas governors, such as Connelly & Co., New York City.

SELF-SEALING MOUTHPIECE DOORS.

Table listing self-sealing mouthpiece doors, such as Smith & Sayre Mfg. Co., New York City.

TAR AND CARBONIC ACID EXTRACTOR.

Table listing tar and carbonic acid extractors, such as Geo. Shepard Page, N. Y. City.

CEMENTS.

Table listing cements, such as C. L. Gerould & Co., Brooklyn, N. Y.

GAS ENRICHERS.

Table listing gas enrichers, such as Standard Oil Co., Cleveland, Ohio.

GAS METERS.

Table listing gas meters and manufacturers, such as John J. Griffin & Co., Phila., Pa.

EXHAUSTERS.

Table listing exhausters, such as The P. H. & F. M. Roots Co., Connersville, Ind.

GAS COALS.

Table listing gas coals and suppliers, such as Penn Gas Coal Co., Phila., Pa.

CANNEL COALS.

Table listing cannel coals, such as Perkins & Co., New York City.

VALVES.

Table listing valves and manufacturers, such as Ludlow Valve Manufacturing Co., Troy, N. Y.

GAS ENGINES.

Table listing gas engines, such as Schleichler, Schumm & Co., Phila., Pa.

ENGINES AND BOILERS.

Table listing engines and boilers, such as Jarvis Engineering Co., Boston, Mass.

STEAM PUMPS.

Table listing steam pumps, such as Van Duzen & Tift, Cincinnati, Ohio.

GAS LAMPS.

Table listing gas lamps and manufacturers, such as Welsbach Incandescent Gas Light Co., Phila., Pa.

PURIFIER SCREENS.

John Cabot, New York City..... 644
Bartlett, Hayward & Co., Baltimore. Md..... 644

GAS STOVES.

American Meter Co., New York and Philadelphia..... 639
The Goodwin Gas Stove and Meter Co., Phila. Pa 620
George M. Clark & Company, Chicago, Ills..... 637
D. McDonald & Co., Albany, N. Y..... 655
Maryland Meter and Manufacturing Co., Baltimore, Md.... 600
Bell & Jones, Philadelphia, Pa..... 654
Chicago Gas Stove Company, Chicago, Ills..... 636

STREET LAMPS.

J. G. Miner, Morrisania, New York City..... 635
Bartlett Street Lamp Man'g Co., New York City..... 635

BURNERS.

C. A. Gefrorer, Phila., Pa..... 652
H. W. Rappleye, Philadelphia, Pa..... 368

STEAM BLOWER FOR BURNING BREESE.

H. E. Parson, New York City..... 644

PURIFYING MATERIAL.

Connelly & Co., New York City..... 643
Friedrich Lux, London, England..... 635
Edgewater Lime Works, Edgewater, N. J..... 636

COKE CRUSHER.

C. M. Keller, Columbus, Ind..... 653

ELECTRICAL APPARATUS.

Wm. Henry White, N. Y. City..... 651

POSITION WANTED

As Superintendent of Gas Works.

Eleven years' experience in the manufacture of coal gas. Best of references given.

778-8

W. L. CARVER, Supt.,
Carthage, Mo.

WANTED,

By middle-aged man,

The Management of Gas Works.

Many years' experience in the management of both small and large works. Best of references from last Company. Address

778-1

"M. A.," care this Journal.

Position Wanted

As Superintendent of Gas Works, or Gas, Electric Light, or Water Works.

Have been Superintendent of gas works for the past 17 years. Formerly acted as Superintendent of water works. Can give the best of references. DAN'L DOUGHERTY,

777-2

Late Supt. Jeffersonville Gas Co.,
Jeffersonville, Ind

WANTED,

By a New England Gas Company,

A Man to Repair Meters, take Meter Readings, etc.

776-5

Address "H. R.," care this Journal.

FOR SALE,

The Ironwork for Twelve Benches of 6's, vis.: Cast Iron Hydraulic Main.

7-inch Dip-Pipes, Stand-Pipes, and Bridge-Pipes, complete.

Floyd Mouthpieces and Self-Sealing Lids, 15x26 in.

Lids and Mouthpieces only in use over a year. Will be sold cheap.

772-1f

ISAAC C. BAXTER,
Detroit (Mich.) Gas Lt. Co

FOR SALE.

A Complete Water Gas Plant.

60,000 Cu. Ft. Daily Capacity.

Fully equipped; all the latest improvements; includes Generator, Purifiers, and Holder. Can be removed to any part of the country, and set up at small cost. For further information apply to BRADFORD GAS LT. & HEATING CO., Dunkirk, N. Y

**FOR SALE,
One Eight-Inch Steam Jet
Exhauster.**

Kerr Murray make, and one of the best. Address
J. B. HOWARD, Supt. Key City Gas Co.,
776-1f Duhuque, Iowa.

**GEROULD'S
System Gas Bookkeeping.**

Approved and adopted by many of the prominent Gas Engineers of the Country.

Sample Sheets and Price-List furnished free on application to

L. P. GEROULD, - - Mendota, Ill.

FRIEDRICH LUX,

Ludwigshafen am Rhein and London.

Lux Mass,
GAS GOVERNORS,
Gas Balance.

Simpkin & Hillyer

RICHMOND, VA.

MANUFACTURERS OF

Gas Works Apparatus

BENCH CASTINGS, CONDENSERS,

Scrubbers, Purifiers, Dry Center Seals,

FOUR-WAY VALVES, GAS VALVES,

SULPHATE OF AMMONIA APPARATUS,
TANKS, ENGINES, BOILERS,
PUMPS, ETC., ETC.

Plans, Specifications and Estimates furnished for new works, or alteration of old works. Correspondence solicited. Works New port News, Va.

Bartlett Street Lamp Mfg. Co.

MANUFACTURERS OF

Globe Lamps,

FOR

Streets, Parks, Public Buildings, Railroad Stations, etc.

LAMP POSTS

A Specialty.



Office and Salesroom,

40 & 42 COLLEGE PLACE, - - N. Y. CITY.

Gas Companies and others intending to erect Lamps and Posts will do well to communicate with us.

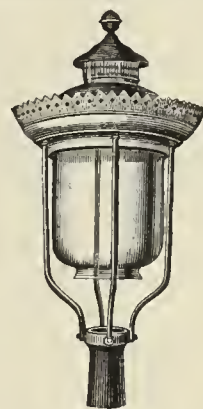
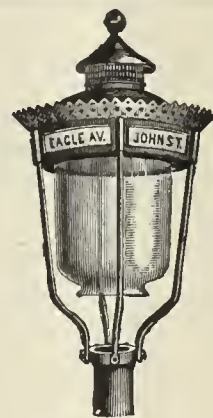

The Miner Street Lamps.

Jacob G. Miner,

No. 823 Eagle Ave., New York, N. Y.

**VAN DUZEN'S
STEAMJET PUMP**

For Water Supply Tanks.
For Fire Pump on Yard or Switch Engines.
For Round House General Work.
For Draining Ponds, Pits, Coffin Dams, etc.
10 Sizes. \$7 to \$75. Thousands in use.
Write for Descriptive Book to VAN DUZEN & TIFT, 106 E. Second St., CINCINNATI, O.

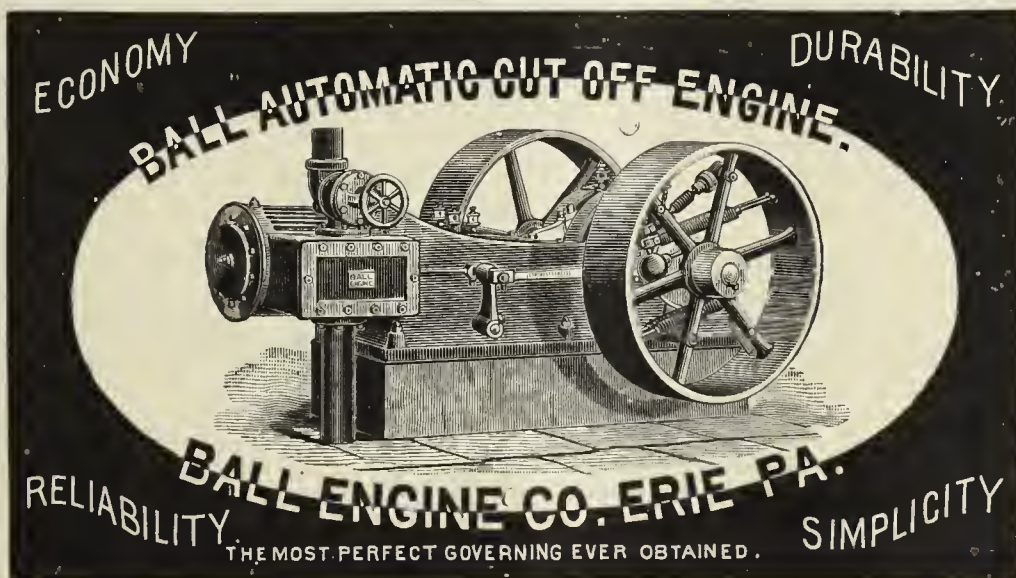

GASHOLDER PAINT.

Use Only

THE GOVERNMENT WATERPROOF PAINT.

Proof against Ammonia, and Absolutely Waterproof. Send for Prices and Particulars.

THE GOVERNMENT WATERPROOF PAINT CO., 122 Milk Street, Boston, Mass.

F. D. HARMON, Pres.

CHAS. C. ALLEN, Sec. and Treas.

P. W. MACKENZIE, Chief Engr.

THE FUEL GAS AND LIGHT IMPROVEMENT CO.

OF AMERICA.

Owner of the Mackenzie Patents of Dec. 31, 1889, and later dates.

For the United States, England, Russia, France, Germany, Austria, and Canada,

No. 32 Park Place, New York City.

This SYSTEM is an ABSOLUTELY NEW DEPARTURE IN THE MANUFACTURE OF FUEL AND ILLUMINATING GAS. The COST OF GAS IN THE HOLDER by our System is at least THIRTY PER CENT. LESS than that made by any other process of the day. The Gas contains neither SULPHUR nor other impurities, nor is there any resultant LAMPBLACK OR TAR RESIDUUM. The Gas is manufactured WHOLLY from LIQUID HYDROCARBONS, such as Lima, Penn. Crude, and Fuel Oils, Naphtha, etc. Neither PERISHABLE PIPES nor other RETORTS, NOR THEIR EQUIVALENTS, are used. Neither COAL, COKE, nor any other HARD CARBONS enter into the manufacture or composition of the Gas, thereby requiring LESS LABOR THAN ANY OTHER METHOD. The APPARATUS is extremely SIMPLE, SUBSTANTIAL, and DURABLE. Works under our system may be CONTINUOUS or ALTERNATING. If alternating, the Nitrogen present will be less than 4½ per cent. If continuous, the limited amount of Nitrogen present is neutralized by Carbon. One gallon of Lima oil by our process EQUALS ALL THE COAL required for making 1,000 feet of carbureted Water Gas.

LACLEDE FIRE BRICK MANUFACTURING COMPANY,

ST. LOUIS, MO.

Exclusive Agents in the United States

FOR THE

**Coze System of
Inclined Retorts.**

IT IS THE COMING BENCH
FOR MAKING COAL GAS.

*It will Save from 50 to
60 per ct. in Labor.*

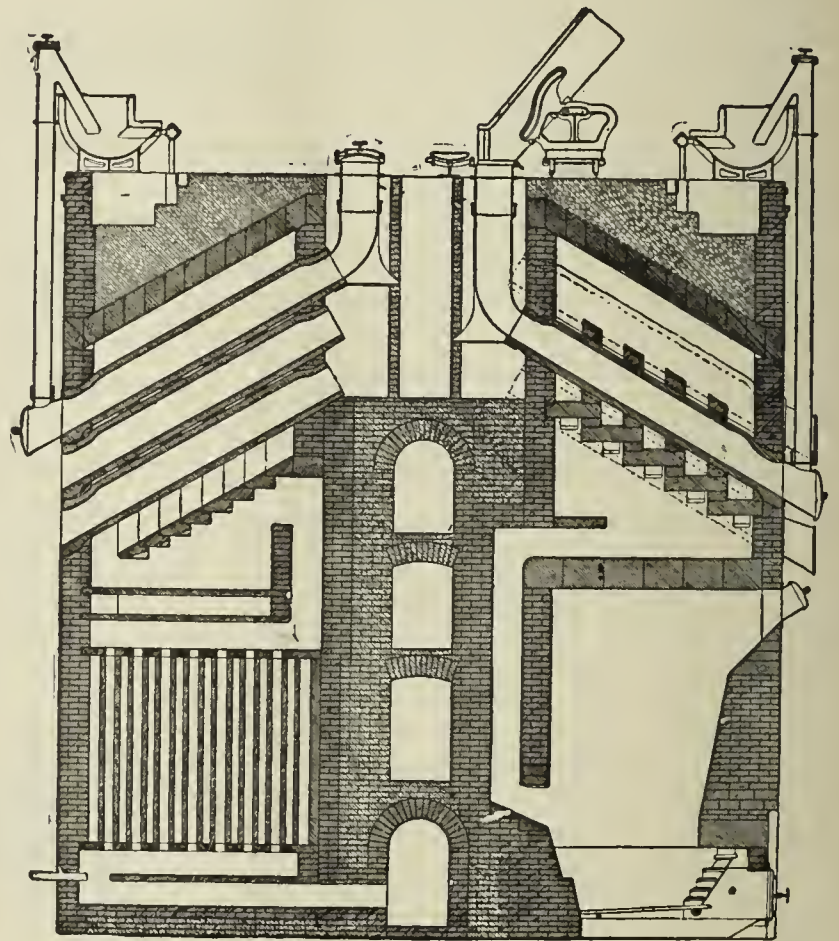
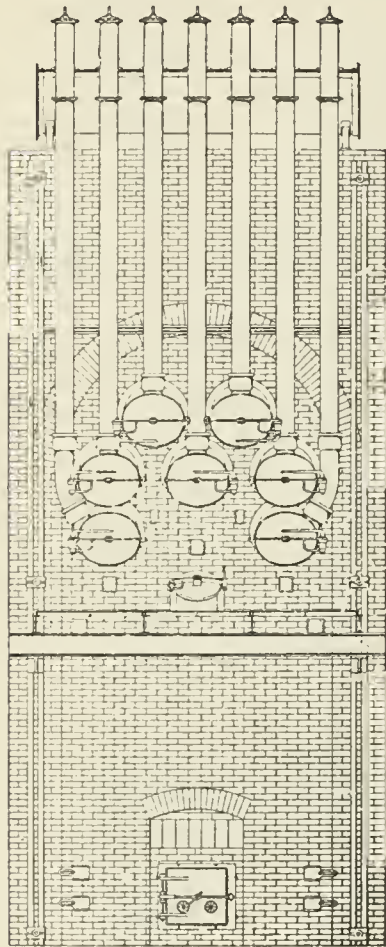

ESTIMATES AND PLANS FURNISHED BY THE

LACLEDE FIRE BRICK MFG. CO., ST. LOUIS, MO.

EDGEWATER LIME WORKS

Chas. F. McKenna, Proprietor.

SHELL LIME.

Lime by the Cargo for Gas Purification.

EDGEWATER, BERGEN CO., N. J.

Write for Testimonials and Prices.

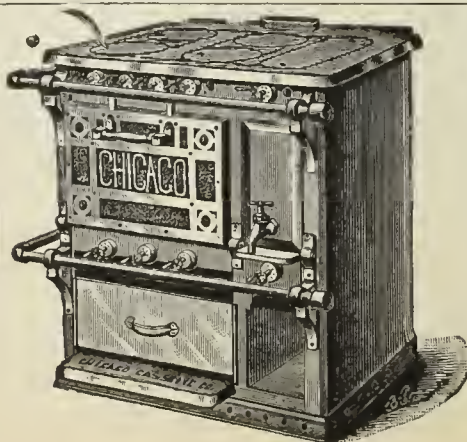

CHICAGO GAS STOVE CO.

MANUFACTURERS OF ALL KINDS OF

Gas Cooking and Heating APPLIANCES.

117-119 Lake St., CHICAGO.

Send for Catalogue.

The Gordon Portico Lamp.

A successful Competitor of the Arc Electric Light for lighting Store Fronts, Show Windows, Depots, Railway Sheds, etc., etc.

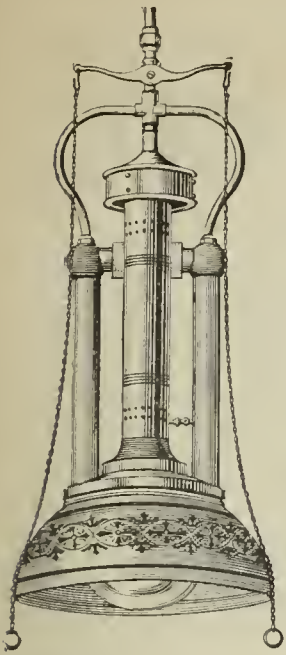

Gordon Portico Lamp.

The Gordon Street Lamp.

A Successful Competitor of the Arc Electric Light for lighting Streets, etc., etc.

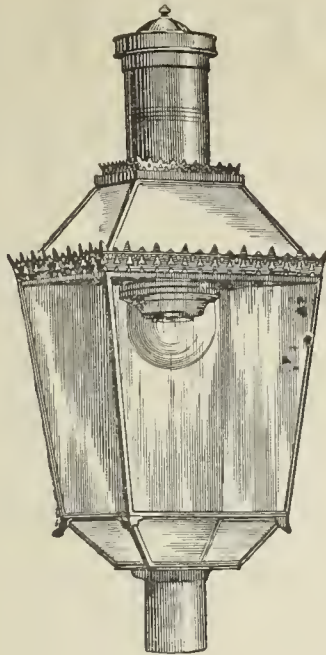

Gordon Street Lamp.

The Lungren Lamp.

A Successful Competitor of the Incandescent Electric Light for Interiors, etc. Is especially applicable for the lighting of Offices, Stores, Factories, Mills, Show Windows, Libraries, and all situations where an increased illumination is desired.

More than 25,000 Lungren Lamps are now in use. Testimonials, references, or any desired information will be cheerfully given.

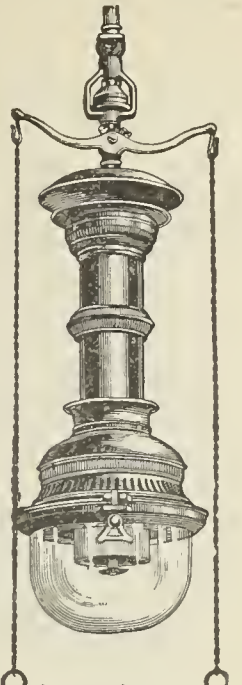

Lungren Lamp.

THE SIEMENS-LUNGREN CO., N.E. Cor. 21st St. & Washington Av., PHILADELPHIA.

WELSBACH SYSTEM OF Incandescent Gas Lighting.

OFFICE, DREXEL BUILDING, PHILA., PA.

At the Fall Session of the Board of Supervisors of Winnebago County, held at the County Court House, Oshkosh, Wis., Nov. 26, 1889, the report submitted by Mr. C. W. Cook, Chairman of the Committee on Public Buildings, recommending the use of the Welsbach Incandescent Gas Burner in the Buildings under their charge, was unanimously adopted, because of the extreme economy in the consumption of Gas and the superior character of the light obtained.

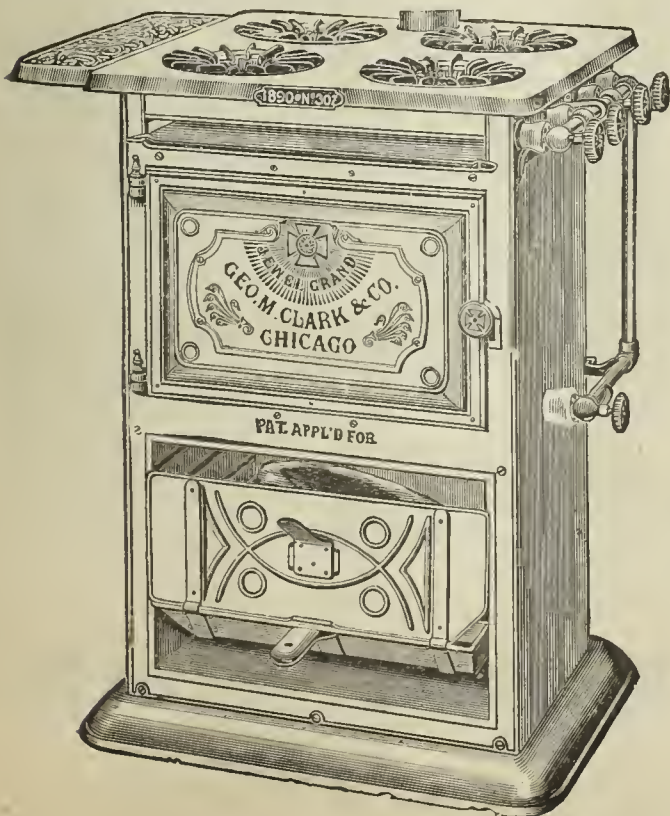

JEWEL GAS STOVES

MANUFACTURED BY

GEORGE M. CLARK & COMPANY,

Nos. 157 & 159 Superior Street, - - - Chicago, Ill.

EVERY CONCEIVABLE SIZE AND STYLE,

Ranging in Prices from \$1.50 to \$30.00.

WE USE NO GAS COCKS.

All Flames are Regulated by a Direct Needle Valve.

The JEWEL

IS THE

Only Well-Made Gas Stove on the Market.

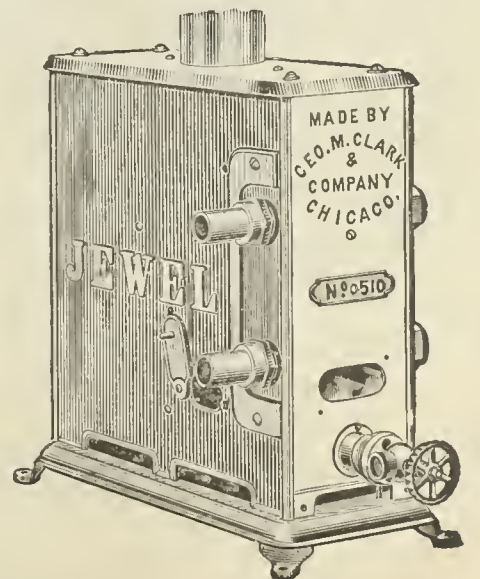

Write for our 1890 Catalogue and see for yourself.

NATIONAL GAS LIGHT AND FUEL CO.,

218 La Salle Street, Chicago.

C. D. HAUKE, Prest. & Gen'l Manager.

A. W. GREEN, Vice-Prest.

N. A. McCLARY, Sec. & Treas.

E. E. MORRELL, Engr.

GAS WORKS

Built, Remodeled, Leased, and Purchased.

71 Springer Cupolas
have been installed
in the U. S. during
the past four years.

The total capacity of
Springer Apparatus
now in use is over
25,000,000 ft. daily.

THE SPRINGER CUPOLA SYSTEM

Has Proven Itself the most Economical and Satisfactory Method of Gas Manufacture ever brought to the attention of the Gas Fraternity.

GUARANTEED ESTIMATES of Cost of Gas Furnished on Application.

GASHOLDER TANK CONSTRUCTION, ETC.

Gas Companies and others about to erect Gasholders will find it profitable to consult W. C. Whyte, who for over 30 years has made a specialty of

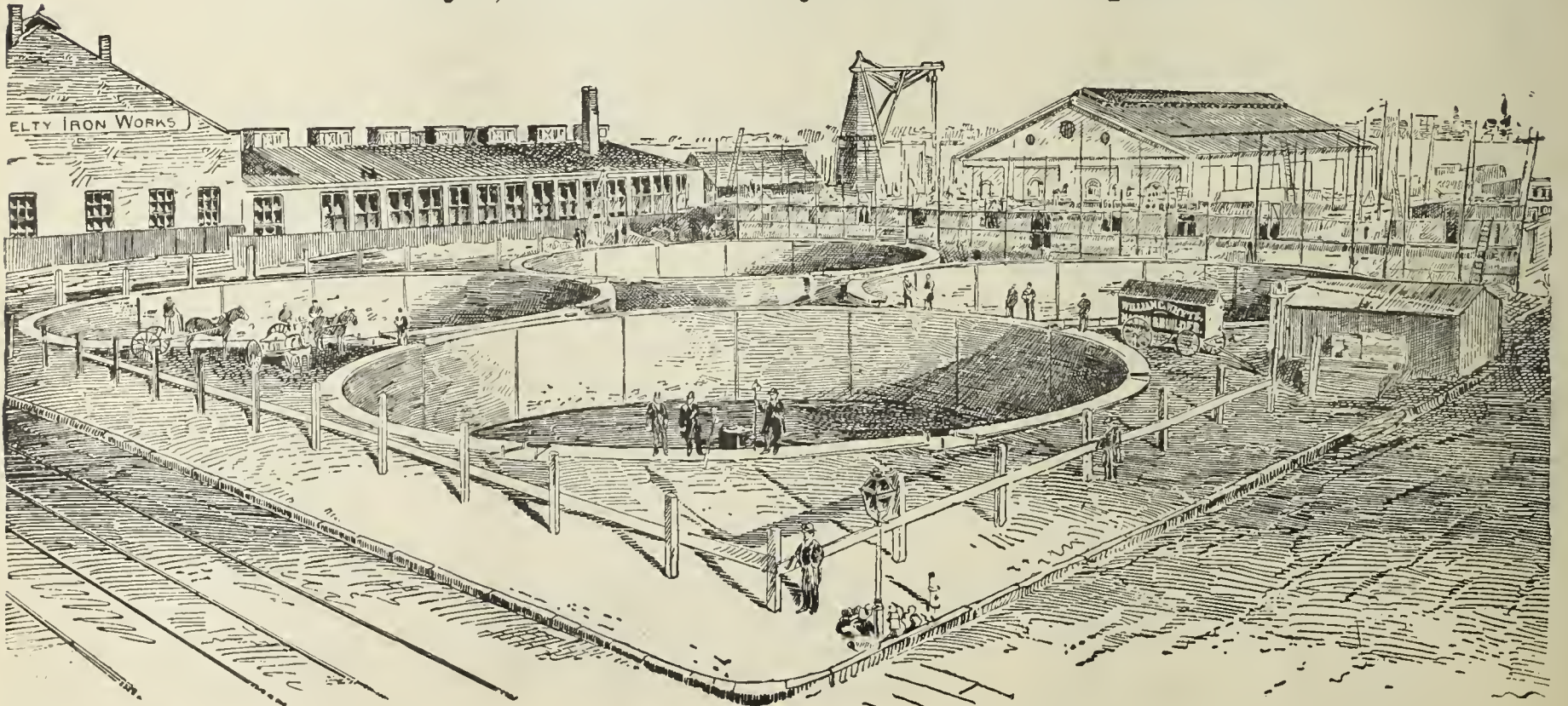

Tank Excavation and Mason Work.

Fifty Tanks now in operation show the sort of work done. Address

W. C. WHYTE, - No. 15 Cortlandt Street, N. Y. City

GAS STOVES.

GAS METERS.

GAS STOVES.

THE AMERICAN METER CO.,

MANUFACTURERS OF

GAS METERS, Station Meters,

METER PROVERS, PHOTOMETERS,

PRESSURE GAUGES OF ALL KINDS,

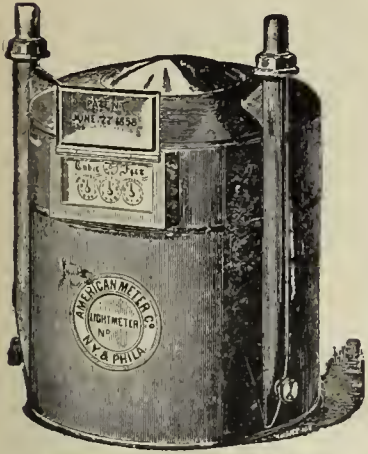

Standard 3 Diaphragm Dry Meter

AND



Standard 2 Diaphragm Dry M r.

Apparatus for Testing the Quantity and Quality of Gases.

GAS STOVES FOR HEATING AND COOKING

Sole Agents in the United States for

Verity's Patent Gas Fires.

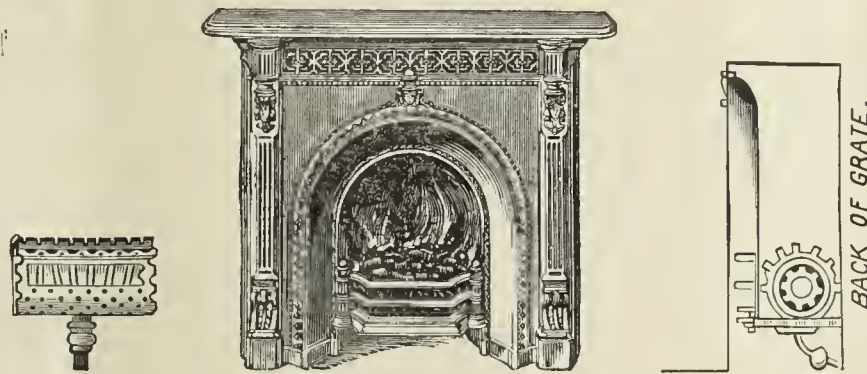

Circulars and Price Lists on Application.

MANUFACTORIES,

508 to 514 West Twenty-second St., N. Y.

Arch and Twenty-second St., Phila.

Nos. 244 & 246 North Wells Street, Chicago, Ill.

AGENCIES,

No. 177 Elm Street, Cincinnati, Ohio.

No. 222 Sutter Street, San Francisco, Cal.

No. 810 North Second Street, St. Louis, Mo.

GAS STOVE SHOW ROOMS, No 242 Sixth Avenue, New York City.

KIRKHAM, HULETT & CHANDLER, LIMITED.

PATENT "STANDARD" WASHER-SCRUBBERS

Erected and in course of construction at present date:

Capacity. Cubic feet per day.	Capacity. Cubic feet per day.	Capacity. Cubic feet per day.	Capacity. Cubic feet per day.
Altrincham..... 600,000	Dublin..... 3,000,000	LONDON—Continued.	Ober Schlesian..... 1,500,000
Adelaide..... 600,000	Dowlais..... 100,000	Shoreditch..... 2,500,000	Otto & Co.'s Coke Works..... 1,500,000
Aldershot..... 200,000	Donai..... 500,000	Pancras..... 1,500,000	Plymouth..... 2,000,000
Allegheny, U. S. A. 1,000,000	Denton..... 500,000	"..... 1,500,000	Parramatta, N. S. W..... 100,000
Ashton-under-Lyne..... 1,250,000	Derby, U.S.A. 350,000	Pimlico..... 2,000,000	Prescott..... 150,000
Amsterdam..... 1,500,000	Deuver, " 500,000	Nine Elms..... 3,000,000	Providence, U.S.A. 750,000
"..... 1,500,000	"..... 1,000,000	"..... 3,000,000	"..... 750,000
Annaberg..... 200,000	Dusseldorf..... 750,000	South Metropolitan Co:—	Plauen..... 300,000
Aracon..... 100,000	"..... 500,000	Greenwich..... 3,000,000	"..... 300,000
Animal Charcoal Co..... 200,000	"..... 500,000	Woolwich..... 400,000	Portsmouth..... 2,500,000
Altoona, U.S.A. 350,000	Dumfries..... 250,000	Vauxhall..... 3,000,000	"..... 2,500,000
Buxton..... 250,000	Dunedin, N.Z..... 400,000	"..... 3,000,000	Pittsburgh, U.S.A. 1,500,000
Bradford..... 1,000,000	Darlington..... 1,250,000	Lea Bridge..... 300,000	Portland, "..... 560,000
"..... 1,250,000	Detroit, U.S.A. 750,000	West Ham..... 1,500,000	Pawtucket, " 500,000
"..... 1,250,000	Edinburgh..... 1,500,000	Leeds..... 2,000,000	Quebec 250,000
"..... 1,250,000	"..... 2,000,000	"..... 3,000,000	Radcliffe..... 750,000
"..... 1,000,000	Enfield..... 300,000	"..... 3,000,000	Ronen..... 250,000
"..... 1,000,000	Essen..... 300,000	"..... 3,000,000	Ramsgate..... 1,000,000
"..... 3,000,000	Elbing..... 150,000	"..... 3,000,000	Reigate..... 200,000
Bremen..... 150,000	Falmouth..... 150,000	"..... 3,000,000	Richmond, U.S.A. 250,000
Baltimore, U.S.A. 1,000,000	Frankfort..... 300,000	"..... 3,000,000	Roxbury, " 500,000
"..... 1,000,000	Farnworth..... 400,000	"..... 3,000,000	Runcorn Soap Co..... 20,000
"..... 1,000,000	Fenton..... 400,000	"..... 2,000,000	Rockhampton, N. S. W..... 125,000
Belmain, N.S.W..... 125,000	Friedenshutte..... 500,000	Leominster..... 150,000	Richmond..... 1,500,000
Bishops Stortford..... 150,000	Furth..... 400,000	Leiden..... 560,000	Reading..... 2,000,000
Blackpool..... 400,000	Freiburg..... 200,000	"..... 600,000	Reichenbach..... 200,000
Brussels..... 1,250,000	Freiburg..... 250,000	Liverpool..... 2,000,000	Salford..... 1,750,000
"..... 1,250,000	Glossop..... 300,000	"..... 2,000,000	"..... 1,750,000
"..... 750,000	Guilford..... 300,000	"..... 2,000,000	"..... 1,750,000
"..... 1,250,000	Gloucester..... 1,250,000	"..... 2,000,000	Smethwick..... 750,000
Banbury..... 250,000	Gera..... 300,000	"..... 2,000,000	Sydney, N. S. W..... 1,000,000
Birmingham..... 5,000,000	Grafton, N.S.W..... 100,000	"..... 3,000,000	"..... 1,000,000
Birkenhead..... 2,500,000	Grieg..... 300,000	"..... 3,000,000	"..... 2,500,000
Blackburn..... 1,500,000	Georgetown, U.S.A. 250,000	Lincoln..... 1,000,000	"..... 50,000
Bochum..... 600,000	Gluckauf..... 200,000	"..... 600,000	"..... 50,000
Burntisland..... 250,000	Heywood..... 600,000	Lowell, U. S. A. 1,000,000	Sunderland..... 1,500,000
Boston, U.S.A. 2,000,000	Hollywood..... 125,000	Louisville 1,500,000	St. Josephs, U.S.A. 250,000
Brisbane..... 1,500,000	Huy..... 70,000	Long Eaton..... 500,000	Spa..... 100,000
"..... 300,000	Harrow..... 250,000	Lilie..... 450,000	Sevenoaks..... 300,000
Burton-on-Trent..... 1,500,000	Harrogate..... 250,000	"..... 750,000	St. Petersburg..... 2,000,000
Barcelona..... 350,000	Halstead..... 150,000	"..... 250,000	"..... 1,500,000
Barking..... 100,000	Heilbronn..... 200,000	"..... 250,000	St. Louis, U.S.A. 2,000,000
Baerlien & Co..... 20,000	Havana, Cuba. 750,000	"..... 250,000	"..... 1,000,000
"..... 20,000	Hastings..... 1,500,000	Luckenwalde..... 330,000	Laclede 1,000,000
Bombay..... 400,000	Huddersfield..... 300,000	Liegwitz..... 300,000	Silesian Coal Co..... 600,000
Buffalo, U.S.A., Mutual 750,000	"..... 750,000	Lincoln, U. S. A. 250,000	San Francisco, U.S.A. 2,000,000
"..... Citizen 500,000	"..... 1,500,000	Lawrence 500,000	"..... 2,000,000
Brookline, U.S.A. 500,000	Hof..... 200,000	Lynn 300,000	Sheepbridge Coal Co..... 40,000
Bergen..... 350,000	Hampton Wick..... 500,000	Lyons..... 1,500,000	Stettin..... 200,000
Berlin..... 1,250,000	Heckmondwicke..... 500,000	Maidstone..... 1,000,000	Singapore..... 300,000
Bournemouth..... 1,000,000	Haverford west..... 100,000	Marseilles..... 1,500,000	Sutton..... 500,000
Bridgeport, U.S.A. 500,000	Haliifax, N.S. 350,000	"..... 1,500,000	Tonbridge..... 150,000
Brunswick..... 300,000	Hamm..... 200,000	Mons..... 500,000	Tipton..... 400,000
Beck & Co., St. Louis 100,000	Halle..... 400,000	Malines..... 250,000	Tottenham..... 1,000,000
Barmen Rittershausen..... 600,000	Heidelberg..... 300,000	Melbourne..... 1,500,000	Toledo, U.S.A. 750,000
Bexhill..... 125,000	Hartford, U.S.A. 1,000,000	"..... 1,500,000	Toronto 1,000,000
Brooklyn, U.S.A. 1,000,000	Ilkeston..... 300,000	"..... 1,500,000	Uxbridge..... 300,000
"..... Nassau 1,000,000	Inverness..... 250,000	Manchester..... 2,500,000	Valparaiso 500,000
Brunner, Mond & Co..... 400,000	Ilkley..... 200,000	Middleton..... 400,000	West Bromwich..... 1,000,000
Cheltenham..... 2,000,000	Ilford..... 100,000	Manley, N. S. W..... 100,000	Willenhall..... 250,000
Cannes..... 200,000	Kingston-on-Hull..... 400,000	Minneapolis, U. S. A. 750,000	Weston-super-Mare..... 500,000
Croydon..... 1,500,000	Kidderminster..... 750,000	Magdeburg..... 300,000	Waltham..... 150,000
Copenhagen..... 200,000	Kidsgrove..... 100,000	Memphis, U. S. A. 750,000	Wormwood Scrubs..... 300,000
Clevedon..... 200,000	Konigberg..... 1,000,000	Nottingham..... 1,250,000	Williamsburg, U.S.A. 600,000
Columbus, U.S.A. 500,000	King's Lynn..... 300,000	"..... 2,500,000	"..... 600,000
Cincinnati, "..... 1,500,000	LONDON:—	"..... 2,500,000	Wellington..... 150,000
"..... 1,500,000	The Gaslight and Coke Co.:	"..... 2,000,000	Warwick..... 300,000
Chicago "..... 3,000,000	Beekton..... 1,250,000	"..... 1,500,000	Wheeling, U.S.A. 500,000
"..... 1,000,000	"..... 1,250,000	"..... 2,000,000	Walker..... 300,000
"..... 1,000,000	"..... 1,250,000	Newport, U.S.A. 430,000	Westgate..... 100,000
Chemnitz..... 1,000,000	"..... 1,250,000	Newmarket..... 150,000	Wilmington, U.S.A. 500,000
Crewe..... 1,250,000	"..... 1,250,000	Newark, U.S.A. 680,000	Windsor, N. S. W..... 100,000
Colonial Gas Works Co..... 100,000	"..... 1,250,000	Northfleet..... 200,000	Wolverton..... 100,000
Cadiz..... 300,000	"..... 2,500,000	New York, U.S.A. 2,000,000	Wellington, N. Z..... 250,000
Charlottenburg..... 600,000	"..... 2,500,000	Nice..... 600,000	Whitechurch..... 175,000
Dudley..... 750,000	Silvertown..... 1,000,000	Newcastle, N. S. W..... 200,000	Washington, U.S.A. 2,000,000
Driffield..... 100,000	Bromley..... 2,000,000	Numea, "..... 100,000	Wallasey..... 750,000
Dukenfield..... 500,000	"..... 1,500,000	Namur..... 250,000	Weimar..... 150,000
Dover..... 750,000	"..... 1,500,000	Newark..... 350,000	Wurzen..... 200,000
"..... 1,000,000	"..... 1,500,000	Oldbury..... 500,000	Worcester, U.S.A. 750,000
Deal..... 200,000	"..... 2,000,000	Otley..... 200,000	Yeadon..... 500,000
Earby 1,500,000	"..... 1,500,000	Oswestry..... 250,000	Yeovil..... 250,000

SOLE AGENT FOR WESTERN HEMISPHERE,

GEO. SHEPARD PAGE, 69 WALL STREET, NEW YORK

THE UNITED GAS IMPROVEMENT CO.

Drexel Building,

CHESTNUT AND FIFTH STREETS,

PHILADELPHIA, PA.

OFFICERS:

WILLIAM W. GIBBS, President.

GEORGE PHILLER, Vice-President.

SAM'L T. BODINE, Gen'l Manager.

RANDAL MORGAN, Gen'l Counsel.

EDWARD C. LEE, Sec'y and Treas.

ALEX. C. HUMPHREYS, Gen'l Supt.

WALTON CLARK, Ass't Gen'l Supt.

H. H. EDGERTON, Chem. and Eng'r.

DIRECTORS:

GEORGE PHILLER,

THOMAS DOLAN,

HENRY C. GIBSON,

WM. T. CARTER,

WILLIAM G. WARDEN,

SAM'L T. BODINE.

BUILDERS, LESSEES AND PURCHASERS OF

➤ GAS WORKS. ➤

ROOTS' GAS AND BYE-PASS VALVES.

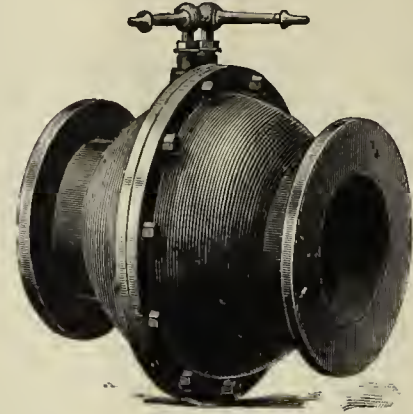
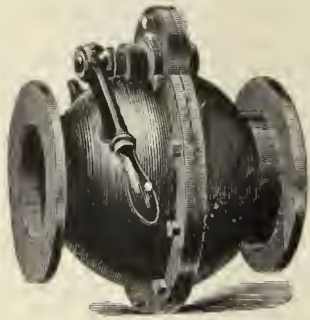

GAS VALVE BYE-PASS VALVE.

Quick Acting,
Simple,
Efficient, Durable.

Automatic Action
Reliable
Simple Durable.

Thousands now in use and giving perfect satisfaction. Write for Catalogue and Prices.

ROOTS' NEW GAS EXHAUSTER.

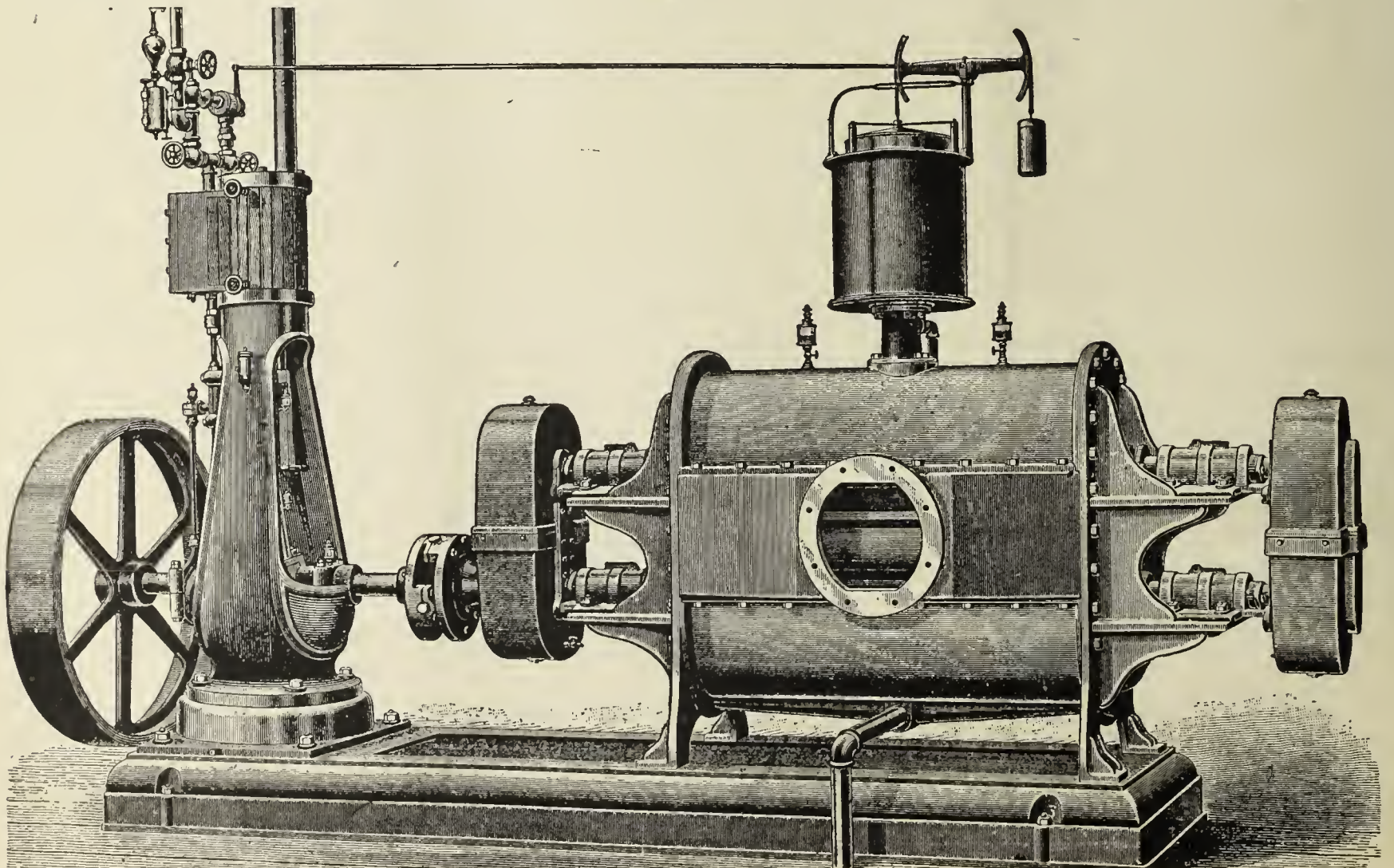

THE P. H. & F. M. ROOTS CO., - - CONNERSVILLE, IND.

S. S. TOWNSEND, Gen. Agt., 22 Cortlandt St., N. Y.

COOKE & CO., Selling Agts., 22 Cortlandt St., N. Y.

CONNELLY & CO.,

SOLE MANUFACTURERS OF THEIR PATENTED SPECIALTIES.

"IRON SPONGE." Saves money, saves labor, and is the most efficient purifying agent ever offered as a substitute for lime. Now used in every State in the Union, and purifying daily over thirty-five million cubic feet. Should be used in every gas works. Its own saving will pay for it many times over.

AUTOMATIC GOVERNOR. Has been on the market but three years, and in that time has been introduced more generally than any invention ever designed for use in gas works. Over two hundred of them now in use. Sensitive; reliable; perfectly automatic; reduces leakage; satisfies consumers, and gives great relief to the Manager. No gas works is complete without one of these machines.

STEAM JET EXHAUSTER. Designed particularly for small works. Combines Exhaust Tube, Steam Governor Gas Compensator, and Bye-Pass Valves in the most compact form possible; occupies but little space; uses very little steam; operated by ordinary workmen; saves formation of carbon in retorts; increases yield 10 to 15 per cent. Specially adapted for mixing air with oil gas. No works too small to use them profitably.

Prices given on all our specialties delivered at any point in the United States. Correspondence solicited.

CONNELLY & CO., No. 111 Broadway, New York City.

WILBRAHAM GAS EXHAUSTER

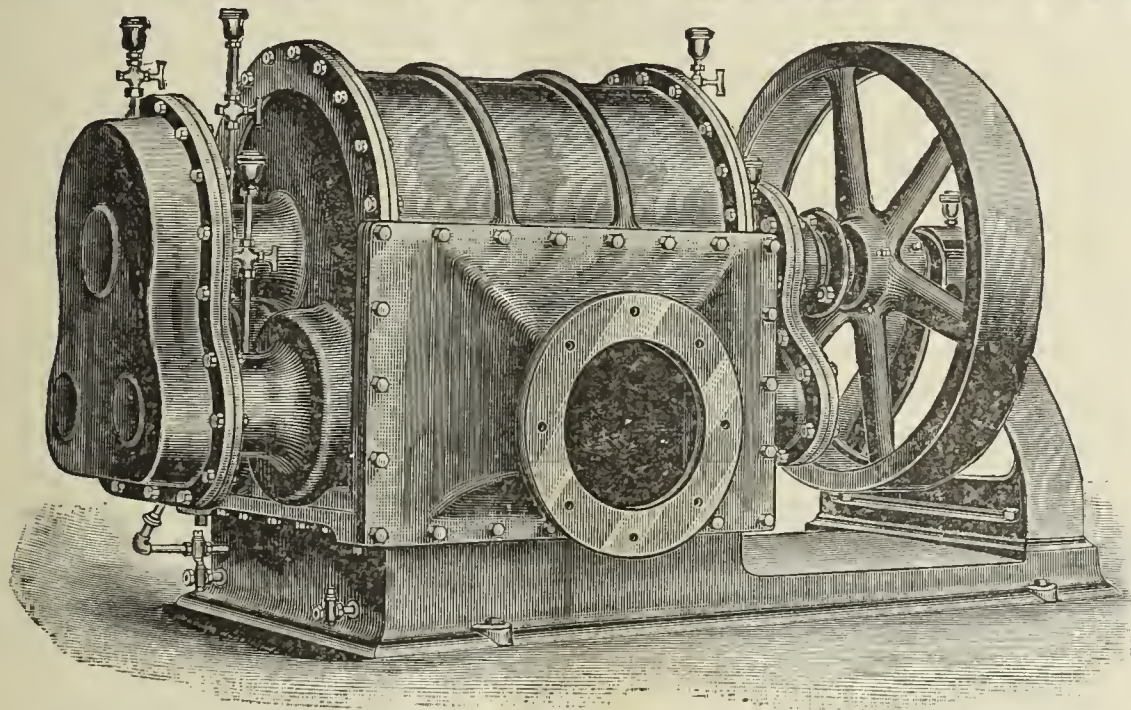

WILBRAHAM BROS.,
PHILADELPHIA, PA.

JARVIS ENGINEERING CO.,

61 Oliver St., Boston, Mass.

CONTRACTORS FOR ERECTING

COMPLETE STEAM OUTFITS FOR ELECTRIC LIGHTING STATIONS.

Steel Boilers set with Jarvis Pat. Boiler Setting

To burn **COKE SCREENINGS** for Fuel.

ARMINGTON & SIMS CO. ENGINES,

Belting direct to Dynamos, without using Shafting.

SEND FOR CIRCULARS.

REFERENCES.—Charlestown Gas & Electric Light Co., Charlestown, Mass.; Schenectady Gas & Electric Light Co., Schenectady N. Y.; Brookline Gas Co., Brookline, Mass.

Practical Electric Lighting

By A. BROMLEY HOLMES, A.M.I.C.E.

With 87 Illustrations. Third Edition. Price, \$1.00.

Electric Light Primer.

By CHARLES L. LEVEY.

A simple and comprehensive Digest of all the most important facts connected with the running of the Dynamo and Electric Lights, with Precautions for Safety, etc.

Price, 50 cents.

A. M. CALLENDER & CO., 42 Pine St., N. Y.

Gasholder Tanks & Gas Works Masonry Complete.

PLANS PREPARED AND ESTIMATES FURNISHED AT SHORT NOTICE.

J. P. WHITTIER, - - 499 Wythe Av., Brooklyn, N. Y.

1889 DIRECTORY 1889

OF THE GAS LIGHT COMPANIES of the UNITED STATES & CANADA.

Price, \$3.00.

A. M. CALLENDER & CO., No. 42 Pine Street, N. Y. City.



CHAPMAN VALVE MANUFACTURING CO.,

MANUFACTURERS OF

Valves and Gates for Gas, Ammonia, Water, Etc.

Also, Gate Fire Hydrants With and Without Independent Nozzle Valve. All Work Guaranteed.

WORKS & GEN'L OFFICE:
Indian Orchard, Mass.

TREASURER'S OFFICE:
72 Kilby & 112 Milk Sts, Boston, Mass.

LUDLOW VALVE MFG. CO.

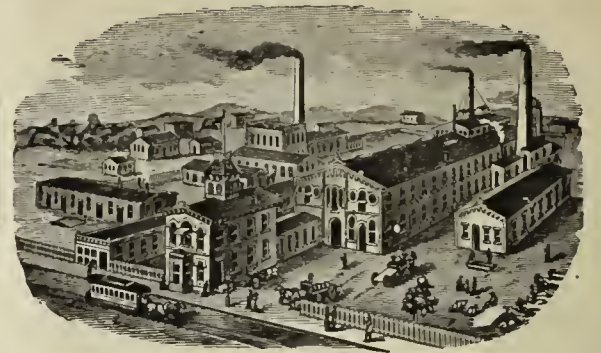

OFFICE AND WORKS,

938 to 954 River Street and 67 to 83 Vail Av.,
TROY, N. Y.

Parson's Steam Blower,

FOR IMPROVING BAD DRAUGHT IN BOILERS, AND FOR BURNING BREEZE OR OTHER WASTE MATERIAL.

PARSON'S TAR BURNER,

FOR UTILIZING COAL TAR AS FUEL.

PARSON'S AIR JET TUBE CLEANER,

FOR CLEANING BOILER TUBES.

These devices are all first-class. They will be sent to any responsible party for trial. No sale unless satisfactory. Manufactured by the WATERTOWN STEAM BLOWER COMPANY.

H. E. PARSON. Supt., 33 & 35 Liberty St., N.Y.

MILLS' REVERSIBLE LIME TRAY,

AND

WOODWORK

Of Every Description

NEEDED BY GAS WORKS.

SEND FOR CIRCULAR AND PRICE LIST TO

BARTLETT, HAYWARD & CO.,

Pratt and Scott Streets, Baltimore, Md.

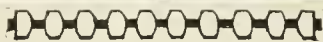
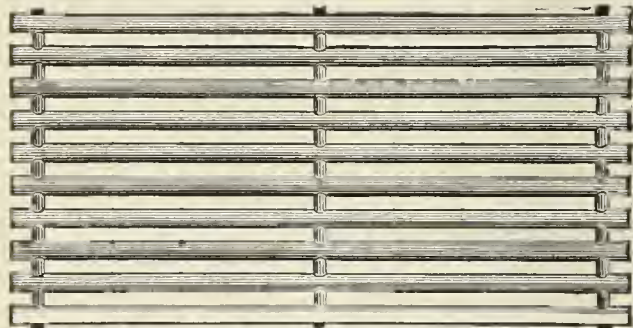

Hydraulic Main Dip Regulators, also Check Valves, Foot Valves, Yard-wash and Fire Hydrants. Send for Circulars.

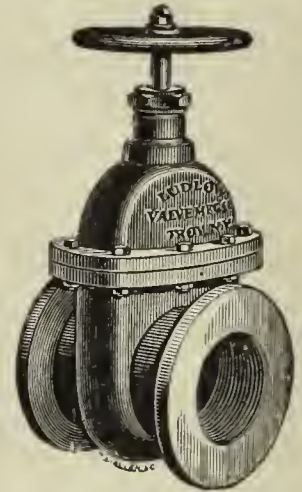

Valves.—Double and Single Gate, 1/2 in. to 48 in., outside and inside Screws. Indicator, etc., for Gas, Water, Steam, and Oil. Send for Circulars.

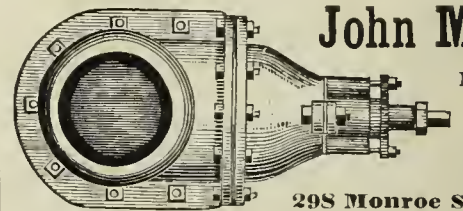

John McLean

Manufacturer

GAS VALVES.

298 Monroe Street, N. Y.

SPECIAL TRAYS FOR IRON SPONGE OR OXIDE OF IRON.

CHURCH'S TRAYS A SPECIALTY.

REVERSIBLE-STRONGEST-MOST DURABLE-MOST EASILY REPAIRED.

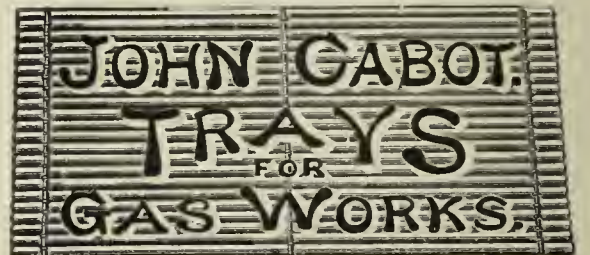

306-310 ELEVENTH AVENUE, NEW YORK.

WE ALSO MAKE THE CHEAPEST AND STRONGEST REVERSIBLE BOLTED TRAYS IN THE MARKET.

VAN DUZEN GAS & GASOLINE ENGINE

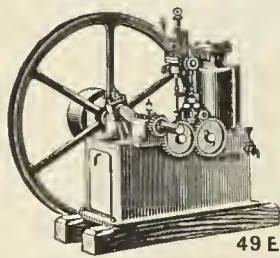

OPERATED with COAL and OTHER MANUFACTURED GASES AND GASOLINE.

RELIABLE AND ECONOMICAL. Fully Warranted

VAN DUZEN Gas & Gasoline Engine Co. 49 E. 2d St., Cincinnati, O.

A. MacKinnon Machine Co., Agts., 22 Warren St., N.Y.

The Management of Small Gas Works.

BY C. J. R. HUMPHREYS.

Price, \$1.

Orders to be sent to A. M. CALLENDER & CO.,

42 PINE STREET, NEW YORK.

THE CLERK GAS ENGINE CO.,

Main Office, 1012, 1014, 1016, 1018 Filbert St., Philadelphia, Pa.

WM. W. GOODWIN, Prest.

E. STEIN, Sec.

S. LEWIS JONES, Asst. Sec.

A. J. DOTY, Supt.

The utility and convenience of the Gas Engine being no longer an open question, it only remains now for intending purchasers to select the BEST. We claim for the CLERK GAS ENGINE that it is equal to any other manufactured as regards steadiness in running, simplicity, and ease of keeping in repair, and that it gives the greatest amount of power for the least money (both in first cost and expense of running) of any engine made. In support of this claim we refer to the test of the Gas Engines made under the direction of the American Institute of New York, in December, 1885, and heretofore published in these columns. These engines are especially adapted for continuous running under heavy loads, and we can refer to Engines which have run 22 hours a day for months at a time.

Made in Sizes of 5 10 15 20, and 25 Horse Power. All Engines Guaranteed for One Year.

ENGINEERS.

GAS AND WATER PIPES.

GAS AND WATER PIPES.

P. D. WANNER, Chairman. A. H. MELLERT, Mangr. of Wks.
R. B. KINSEY, Secretary. F. A. KNOPP, Treasurer.

MELLERT FOUNDRY & MACHINE CO. Ltd.
and **READING FOUNDRY CO., Ltd.**
Reading, Pa.



Specials—Flange Pipe, Valves and Hydrants
Lamp Posts, Retorts, etc.
General Foundry and Machine Work.
JOHN FOX, Selling Agent. 160 Broadway. N. Y.

THE OHIO PIPE COMPANY,

MANUFACTURERS OF

Cast Iron Gas & Water Pipe,

BRANCH AND SPECIAL CASTINGS.

Gas-House Bench Castings, Hydraulics, Lamp Posts, Flange Pipe
and Specials, Architectural Castings, Building Columns,
Joists, Cellar Grates, Sash Weights, etc.

GENERAL FOUNDERS AND MACHINISTS.

Columbus, Ohio.

M. J. DRUMMOND,



SPECIAL CASTINGS AND LAMP POSTS.
Office, Corbin Building, 192 Broadway, N. Y.

EMAUS PIPE FOUNDRY.

DONALDSON IRON COMPANY. EMAUS, PA.



MANUFACTURERS OF

CAST IRON PIPE AND SPECIAL CASTINGS
FOR WATER AND GAS.

JOS. R. THOMAS,

No. 42 Pine Street, N. Y. City.

CONSULTING AND CONSTRUCTING

Gas Engineer and Contractor.

PLANS, SPECIFICATIONS, AND ESTIMATES
FURNISHED.

Contracts taken for all Appliances
required at a Gas Works,

Either for New Works or Extensions to Old Plants.

WM. MOONEY

(Successor to WM. FARMER)

No. 94 Liberty St., N. Y. City.

GAS ENGINEER AND CONTRACTOR FOR THE ERECTION
OF GAS WORKS, OR APPARATUS OF ANY
CAPACITY.

Plans and Specifications Furnished.

WM. GARDNER,

Gas Engineer,

Lewis Block, Room 20, Pittsburgh, Pa.

Those who intend to make alterations in existing gas plants, or
who contemplate the erection of new works, will find it to their
interest to open correspondence with the above. Plans made
and estimates furnished.

SAM'L R. SHIPLEY, Pres.
HENRY B. CHEW, Tre

JAS. P. MICHELLON, Sec.
WM. SEXTON, Supt.

GLOUCESTER IRON WORKS,
GLOUCESTER CITY, N. J.



Cast Iron Gas & Water Pipes, Stop Valves, Fire Hydrants, Gasholders. &c.

Office, Rooms 61 and 63 Bullitt Building, 131 S. 4th St., Phila., Pa.

WARREN FOUNDRY AND MACHINE CO.,

Established 1856. Works at Phillipsburgh, N. J.

New York Office, 160 Broadway.

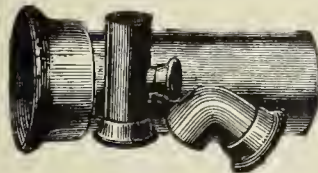

CAST IRON WATER AND GAS PIPE,

FROM TWO TO FORTY-EIGHT INCHES DIAMETER. ALSO, ALL SIZES OF

Flange Pipe for Sugar House and Mine Work. Branches, Bends, Retorts, etc., etc.

DENNIS LONG & COMPANY,

LOUISVILLE, KY.,



CAST IRON GAS & WATER PIPE & SPECIAL CASTINGS
OF ALL SIZES.

King's Treatise on Coal Gas.

A standard text-book for the Engineers and Managers of Gas Works, and for all who are concerned
or take an interest in the manufacture and distribution of Coal Gas, and in the utilization of the
Secondary Products resulting therefrom; treating also of the Gas Engine, and of Gas Cooking and
Heating Appliances.

In 3 Vols. Price per Vol., \$10. Sold either by Volume or in Sets.

A. M. CALLENDER & CO., 42 Pine St., N. Y.

RETORTS AND FIRE BRICK.

J. H. CAUTIER & CO.,

CORNER OF

GREENE AND ESSEX STREETS,

JERSEY CITY, N. J.

MANUFACTURERS OF

Clay Gas Retorts,**Gas House Tiles,****Fire Bricks, Etc. Etc.****Ground Clay, Fire Brick and****Fire Sand in Barrels,**

J. H. GAUTIER. C. E. GREGORY. C. E. GAUTIER.

BROOKLYN**Clay Retort & Fire Brick Works,**

(EDWARD D. WHITE & CO.)

Manufacturers of Clay Retorts, Fire Brick,**Gas House and other Tile.**

VAN DYKE, ELIZABETH, RICHARDS & PARTITION STS.

Office, 88 Van Dyke St., Brooklyn, N. Y.

RETORTS AND FIRE BRICK.

LACLEDE FIRE BRICK MFG. CO.,

MANUFACTURERS OF

Fire Brick, Gas Retorts,

AND

ST. LOUIS STANDARD SEWER PIPE.

Blast Furnace and Cupola Linings, every description of Fire Clay Material, Fire Clay Flue Linings, Chimney Tops Dry Milled and Crude Fire Clays, etc.

OFFICE AND DEPOT

901, 903, and 905 Pine Street,

ST. LOUIS, MO.

ESTABLISHED IN 1845.

B. KREISCHER & SONS,

OFFICE FOOT OF HOUSTON ST., E.R., N.Y.

Gas Retorts,**TILES, FIRE BRICK.**

AND EVERYTHING IN THE FIRE CLAY LINE.

RETORTS AND FIRE BRICK.

MANHATTAN

FIRE BRICK & ENAMELLED CLAY

RETORT WORKS**ADAM WEBER.****CLAY GAS RETORTS**

AND RETORT SETTINGS

FIRE BRICKS, TILES, ETC.,

Office and Works, 15th Street and Avenue C., N. Y.

Works,
LOCKPORT STATION, PA.

—ESTABLISHED 1864.—

JAMES GARDNER, JR.,

Successor to WILLIAM GARDNER & SON.

Office, Rooms 19 & 20, Lewis Block,
PITTSBURGH, PA, P. O. Box 373.**Fire Clay Goods for Gas Works.**

H. A. NORTON, No. 4 CENTRAL STREET, BOSTON, MASS., Agent for the New England States.

GEO. C. HICKS, Prest. CHICAGO CHAS. A. REED, Sec. & Treas.

Retort and Fire Brick Co.,

MANUFACTURERS OF

Fire Clay Goods of all Kinds,

AND BEST QUALITY ONLY.

Regenerative Furnaces & Water Gas Goods.

45th St., Clark to La Salle, Chicago.

GEROULD'S IMPROVED RETORT CEMENT.

A Cement for patching retorts, putting on mouthpieces, and making up all bench-work joints. This Cement is mixed ready or use. Economic and thorough in its work. Fully warranted o stiek. For recommendations and price list address

C. L. GEROULD & CO.,

5 & 7 Skillman St., Brooklyn, N. Y.

Western Agent, H. T. GEROULD, Mendota, Ill.

**Parker-Russell
Mining and Mfg. Co.,**

CITY OFFICE,

Mermod-Jaccard Bldg., Rooms 307 & 308,
Broadway & Locust St., St. Louis. Mo.

PROPRIETORS OF THE

OAKHILL GAS RETORT & FIRE BRICK W'KS

Our immense establishment is now employed almost entirely in the manufacture of

Materials for Gas Companies

We have studied and perfected three important points. Our retorts are made to stand changes of temperature, the strongest heats of the furnace, and the abrasion of feeding and emptying. We have the exclusive Agency for the West of the celebrated

Kloenne-Bredel Full Depth and Semi-Recuperator Benches,

And also furnish and build

Our Own Styles Semi-Recuperator Furnaces for the use of Coal or Coke as fuel.

THOS. SMITH, Prest. AUGUST LAMBLA, Vice-Prest. & Supt.

BALTIMORE**RETORT & FIRE BRICK CO.**

MANUFACTORY AT

LOCUST POINT, BALTIMORE, MD.

Clay Retorts, Blocks & Tiles**FIRE BRICK, FIRE CLAY,
AND FIRE CEMENT.****Red and Buff Ornamental Tiles and Chimney Tops. Drain and Sewer Pipe (from 2 to 30 inches). Baker Oven Tiles 12 x 12 x 2 and 10 x 10 x 2.**

WALDO BROS., 88 WATER ST., BOSTON, MASS

Sole Agents the New England States.

Boston Fire Brick Works Manufacturers of **Gas Retorts and Settings**

Under the Personal Supervision of MR. GEO. C. HICKS late of Chicago.

Fire Clay Goods of all kinds. Akron Sewer Pipe, Lime, Cement, etc. Agts. for the Arc Gas Lamp & Governing Gas Burners.

Send for Circulars and Prices to

FISKE, COLEMAN & CO., Managers, No. 62 Congress Street, Boston, Mass.

HENRY MAURER & SON,
 (ESTABLISHED 1856.)
EXCELSIOR FIRE BRICK & CLAY
RETORT WORKS
 WORKS, Perth Amboy, N. J.
 OFFICE, 418 to 422 East 23d St., N. Y.
Clay Gas Retorts,
BENCH SETTINGS,
 Fire Brick, Tiles, Etc.

FLEMMING'S
Generator-Gas Furnace

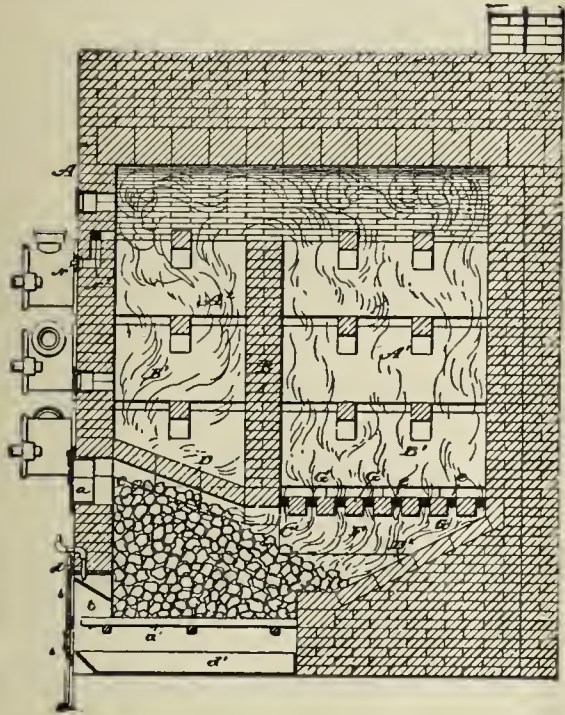

Materials furnished and Benches erected by

J. H. GAUTIER & CO., - Jersey City, N. J.
 Address as above, or D. D. FLEMMING, Jersey City, N. J.

FRED. BREDEL,
 CONTRACTOR FOR THE COMPLETE
Erection and Equipment of Gas Works.
 SOLE PROPRIETOR OF THE
KLOENNE PATENTS
 FOR NORTH AMERICA.
REGENERATIVE FURNACES.

(900 Retorts are now fired in America by the Kloenne-Bredel System.)

SELF-SEALING MOUTHPIECES.

(Over 800 Now in Use.)

Standard Condensers. Washer-Scrubbers.

TAR WASHERS FOR WATER GAS PLANTS.

(In use in the works of the Chicago Gas Lt. Co.)

GASHOLDERS.

Bredel's Automatic Gas Governor.

Refers, by permission, to Mr. Eugene Vanderpool, Newark, N. J.; Mr. E. G. Cowdery, Milwaukee, Wis.; and Mr. Theo. Forstall, Chicago, Ills. For further information, address

FRED. BREDEL,
No. 208 East Seventeenth Street, N. Y. City.

SCIENTIFIC BOOKS.

- | | | |
|---|---|---|
| <p>KING'S TREATISE ON THE MANUFACTURE OF COAL GAS. Three vols.; \$10 per vol.</p> <p>GAS MANUFACTURE, by WILLIAM RICHARDS. 4to., with numerous Engravings and Plates, in Cloth binding. \$12.</p> <p>TECHNICAL GAS ANALYSIS. \$2.80.</p> <p>GAS CONSUMER'S GUIDE. \$1.</p> <p>A GUIDE TO GAS LIGHTING. 40 cents.</p> <p>GAS MEASUREMENT AND GAS METER TESTING, by F. W. HARTLEY. \$1.60</p> <p>GAS CONSUMER'S HANDBOOK, by WILLIAM RICHARDS, C.E.; 18mo., Sewed. 20 cents.</p> <p>A PRACTICAL TREATISE ON GAS AND VENTILATION with Special Relation to Illuminating, Heating, and Cooking Gas, by E. E. PERKINS. \$1.25.</p> <p>PRACTICAL TREATISE ON HEAT, by THOMAS BOX. Second edition. \$5.</p> | <p>GAS WORKS—THEIR ARRANGEMENT, CONSTRUCTION, PLANT, AND MACHINERY. \$8.</p> <p>COAL; ITS HISTORY AND USE, by PROF. THORPE. \$3.50.</p> <p>THE GAS WORKS OF LONDON, by COLBURN. 60 cents.</p> <p>THE GAS FITTER'S GUIDE, Showing the Principles and Practice of Lighting with Coal Gas, by JOHN ELDRIDGE. 40 cents.</p> <p>GAS WORKS, AND MANUFACTURING COAL GAS, HUGHES. \$2.20.</p> <p>THE MANAGEMENT OF SMALL GAS WORKS, by C. J. R. HUMPHREYS. \$1.</p> <p>MANUAL FOR GAS ENGINEERING STUDENTS, by D. LEE, 40 cents.</p> <p>HOW TO MANAGE GAS, by F. WILKINS. Paper. 20 cents.</p> <p>THE DOMESTIC USES OF COAL GAS, AS APPLIED TO LIGHTING, by W. SUGG. \$1.40.</p> <p>DIGEST OF GAS LAW. \$5.</p> | <p>DISTILLATION OF COAL TAR AND AMMONIACAL LIQUOR, by GEO. LUNGE. New Edition. \$12.50.</p> <p>A TREATISE ON THE COMPARATIVE COMMERCIAL VALUES OF GAS COALS AND CANNELS, by D. A. GRAHAM 8vo., Cloth. \$3.</p> <p>GAS COMPANIES DIRECTORY. \$3.</p> <p>GAS VERSUS ELECTRIC LIGHT. 50 cents.</p> <p>THE AMERICAN GAS ENGINEER AND SUPERINTENDENT'S HANDBOOK, by WM. MOONEY. \$3.</p> <p>GAS ENGINE INDICATOR DIAGRAM, by W. E. AYRTON. Paper. 20 cents.</p> <p>ILLUMINATING AND HEATING GAS, by W. BURNS. \$1.50.</p> <p>TESTING PIPES AND PIPE JOINTS, by M. M. PATERSON. 80 cents.</p> <p>DESIGNING WROUGHT AND CAST IRON WORK, by H. ADAMS. Paper. Three parts, 60 cents each.</p> <p>NOTES IN MECHANICAL ENGINEERING, by H. ADAMS. \$1.</p> <p>STRAINS IN IRONWORK, by H. ADAMS. With plates. \$1.75</p> |
|---|---|---|

The above will be forwarded by express, upon receipt of price. If sent by mail, postage must be added to above prices. We take especial pains in securing and forwarding any other Works that may be desired, upon receipt of order. All remittances should be made by check, draft, or post office money order.

A. M. CALLENDER & CO., 42 Pine Street, New York.

Newbigging's Handbook for Gas Engineers and Managers.

The present (the fifth) edition marks an important advance on those that have gone before. Considerable additions have been made to the text, and much of it has been re-written and otherwise improved. It extends to 524 pages, and contains 193 illustrations. **Price, Cloth, \$6.00.**

A. M. CALLENDER & CO., - - - No. 42 Pine Street, N. Y. City.

DAVIS & FARNUM MFG. CO.,

WALTHAM, MASS.

PRINCIPAL OFFICE AND WORKS, Waltham, Mass.

BOSTON OFFICE, Room 55, Mason Building, 70 Kilby Street.

SINGLE, DOUBLE,
AND
TRIPLE LIFT

Gas holders.

OF ANY CAPACITY.

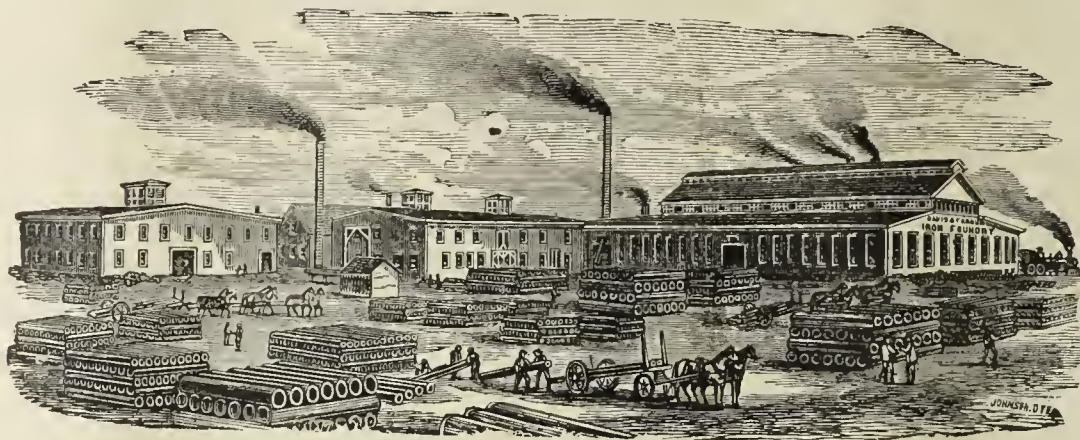

TUBULAR, PIPE,
AND
SINUOUS FRICTION

Condensers.

OF ALL SIZES.

IRON ROOF FRAMES AND FLOORS.

Purifying Boxes, Center Seal or Valve Connections, Bench Work.

Reversible Lime Trays.

SELF-SEALING AND PRESSED STEEL MOUTHPIECE LIDS.

Coke Barrows, Coal Wagons, and all Apparatus Requisite for a Complete Gas Plant.

— ALSO —

Gas and Water Pipe, Flanged Pipe,

Sugar House Work, and Special Castings of all Descriptions.

Established 1861.

Incorporated 1881.

KERR MURRAY MFG. CO.,

FORT WAYNE, IND.

Those who are in need of

Holdings of Gas Works Apparatus of any Description,

AND OF THE LATEST IMPROVEMENTS,

will find it to their interest to

GET AN ESTIMATE FROM US

before placing their order.

As we make a Specialty of this Class of Work, and are Practical Builders and Manufacturers of same,

with our long years of experience in the business,

WE CAN GUARANTEE YOU SATISFACTION.

Estimates, Plans and Specifications Furnished on Application.

BARTLETT, HAYWARD & CO.

Baltimore, Md.

Triple Double, & Single-Lift
GASHOLDERS.

Iron Holder Tanks.

ROOF FRAMES.

Cirders.

BEAMS.

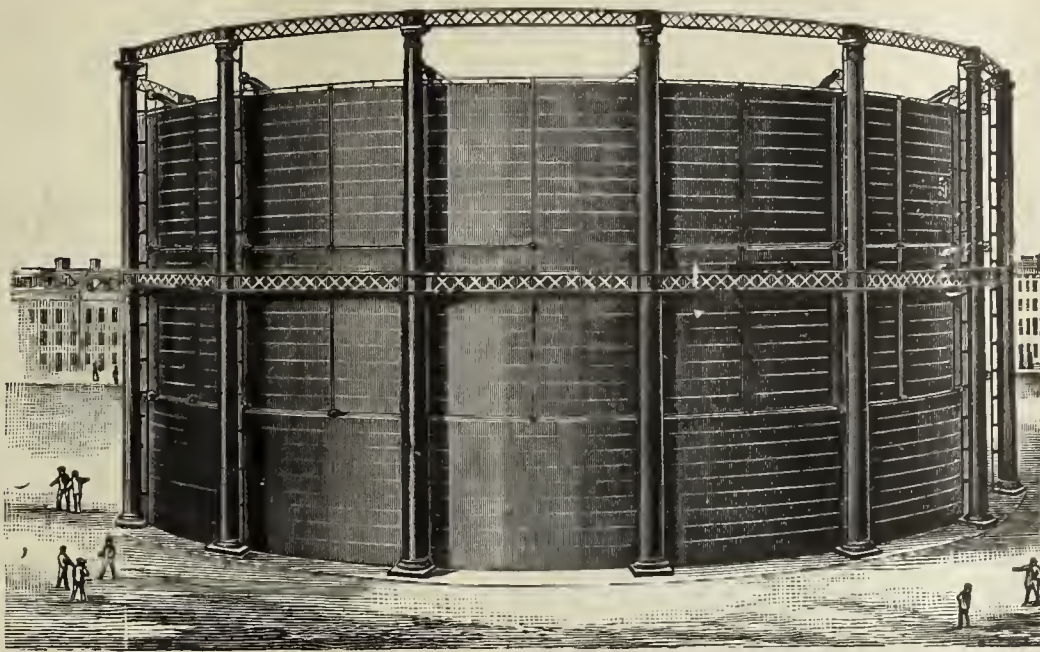

PURIFIERS.

CONDENSERS.

Scrubbers.

BENCH CASTINGS.

OIL STORAGE TANKS.

Boilers.

The Wilkinson Water Gas Process.

THIRTY-CANDLE, NON-CONDENSABLE, FIXED GAS. THE MOST SUCCESSFUL GAS PROCESS IN OPERATION.

Munich Regenerative Furnace, System Drs. Schilling & Bunte.

HAZELTON BOILERS.

Gas Works Designed and Constructed.

Pascal Iron Works. ESTABLISHED 1821. Delaware Iron Works.

MORRIS, TASKER & CO.,

INCORPORATED.

OFFICE, 224 SOUTH THIRD STREET, - - PHILADELPHIA, PA.

CONTRACTORS, BUILDERS, AND MANUFACTURERS OF

Gas, Water & Sugar Works

Bench Castings.

Condensers.

Scrubbers.

Purifiers.

Hyd. Carriages.

Iron Floors,

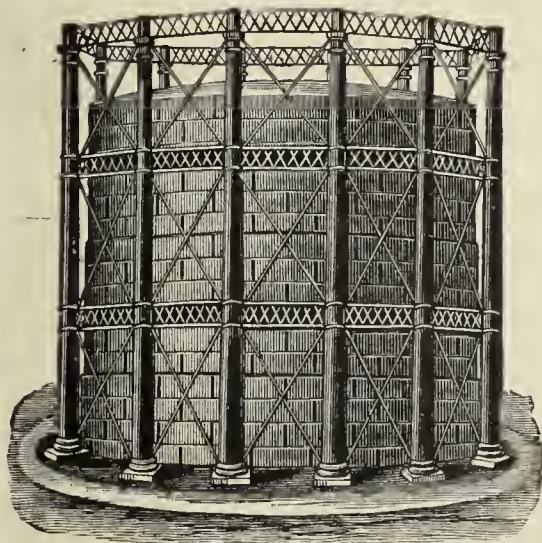

Iron Roofs.

Street Stops,

Valves, etc.

Stand-Pipes.

Water & Oil

Tanks, all Sizes.

Single, Double, and Triple-Lift Gas Holders.

SELF-SEALING RETORT LIDS. STAMPED STEEL RETORT LIDS.

Locomotive Water Columns, Filters, etc. Boiler Tubes, Wrought Iron Pipe & Fittings

Plans, Specifications and Estimates for all kinds of Machinery furnished on application.

Foundries & Works,
MILLVILLE, FLORENCE,
and CAMDEN, N. J.

R. D. WOOD & CO.,

Engineers,
Iron Founders,
and
Machinists.

400 Chestnut St., PHILADELPHIA, PA.

MANUFACTURERS OF

CAST IRON PIPE,

Gas Holders,

SINGLE, DOUBLE, AND TRIPLE LIFTS, WITH
OR WITHOUT WROUGHT IRON
OR STEEL TANKS.

PURIFIERS, CONDENSERS.

Scrubbers.

BENCH WORK.

Iron Floors and Roofs, Plate Girders.

Heavy Loam Castings

HYDRAULIC WORK.

Lamp Posts, Valves, Etc.

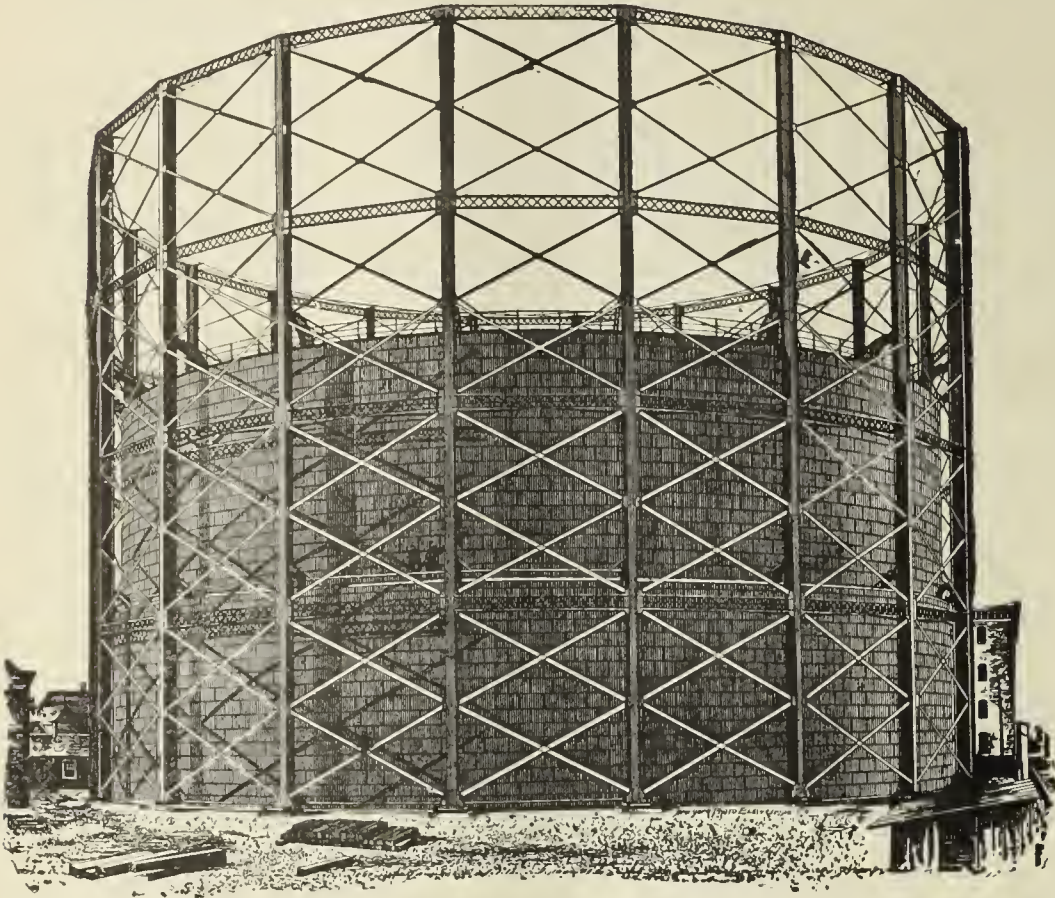

SMITH & SAYRE MFG. COMPANY,

G. G. PORTER, Prest.

245 Broadway, N. Y.

CHAS. W. ISBELL, Sec'y.

Machinery & Apparatus for Gas Works

Drawings, Plans, and Estimates Furnished for the Improvement, Extension, or Alteration of Gas Works, or for the Construction of New Works.

Mackenzie's Patent Rotary and Steam Jet Gas Exhausters, Governors, Compensators, Condensers, Washers, Scrubbers. Isbell's Patent Automatic Street Pressure Governor, Gas and Water Valves, Hydraulic Main Dip Regulator, Bench Castings, etc. Purifying Boxes and "Standard" Scrubbers. Isbell's Patent Self-Sealing Retort Doors

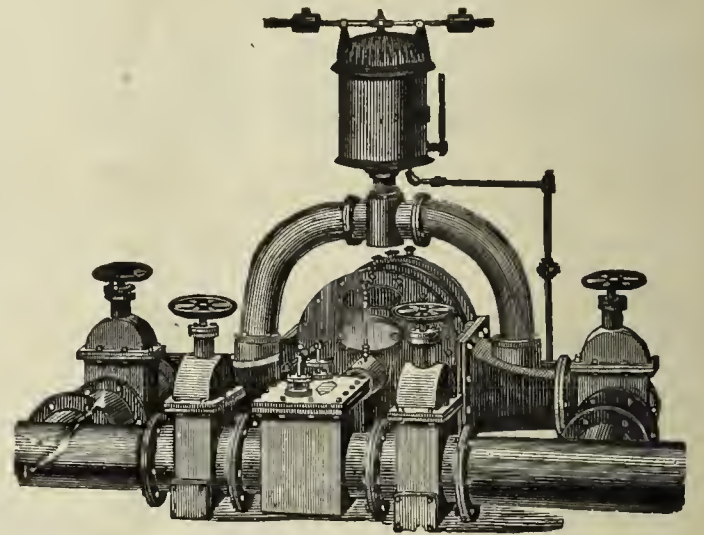

THE BRENNER SELF-SEALING RETORT DOOR.

Simple, Strong, and Durable.

CLOSES ABSOLUTELY TIGHT & IS LOCKED BY A CAM LEVER. ALL NECESSARY ADJUSTMENT FOR WEAR PROVIDED.

BUILT BY

SMITH & SAYRE MFG. CO.,

No. 245 Broadway, - - - New York City.

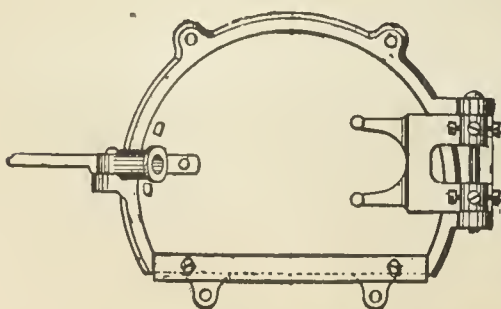

Brenner Self-Sealing Retort Door.

WILLIAM B. LUNDIE, Superintendent of the 42d Street Station of the Consolidated Gas Company, of New York, writes, under date of Jan. 4, 1889:

"We have 320 Brenner Self-Sealing Lids in use at this Station, built by the Smith & Sayre Mfg. Co. They require very little attention, and are the best of the kind that I have seen, giving entire satisfaction."

GAS WORKS APPARATUS AND CONSTRUCTION.

GAS WORKS APPARATUS AND CONSTRUCTION.

JAMES R. FLOYD & SONS,

(SUCCESSORS TO HERRING & FLOYD)

Oregon Iron Works,

W. 20th & 21st. Sts., bet. 10th & 11th Avs.,

NEW YORK CITY.

Engineers and Contractors

FOR THE

CONSTRUCTION OF GAS WORKS.

MANUFACTURERS OF

All Kinds of Castings and General Ironwork

FOR

GAS APPARATUS.

Bench Castings, Regenerative and Half Regenerative Furnace Castings.

Condensers, Scrubbers, Purifiers, Street Drips and Connections,

Valves,

Hydraulic Hoisting Purifier Carriage, Self-Sealing Retort Lids, Improved

Valve Stand and Indicator,

Seller's Cement.

Plans, Specifications, and Estimates furnished for Construction of New or Alteration of Old Works.

CONTINENTAL IRON WORKS.

THOS. F. ROWLAND, Prest.

WARREN E. HILL and CHAS. H. CORBETT, V-Prests.

THOS. F. ROWLAND, JR., Sec. & Tr

P. O. Station G., BROOKLYN, N. Y.

ENGINEERS AND MANUFACTURERS OF

Gas Holders

CONDENSERS, SCRUBBERS, VALVES,

PURIFIERS, SELF-SEALING RETORT LIDS

Hydraulic Mains,

And all other articles connected with the manufacture and distribution of Gas.

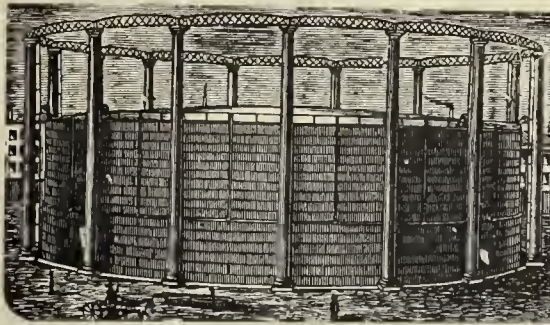

H. RANSHAW, Prest. & Mangr.

WM. STACEY, Vice-Prest.

T. H. BIRCH, Asst. Mangr.

R. J. TARVIN, Sec. & Treas.

STACEY MFG. CO.,

MANUFACTURERS OF

Single and Telescopic Gasholders,

IRON ROOFS, BRIDGES, LAMP POSTS,

Water and Oil Tanks, Coal Elevator Cars,

COKE CRUSHERS, BENCH CASTINGS,

And all kinds of Wrought and Cast Iron Work used in the erection of Coal and Oil Gas Works Rolling Mill Machinery and Heavy Castings a Specialty.

Foundry:

33, 35, 37 & 39 Mill Street.

Wrought Iron Works:

16, 18, 20, 22, 24 & 26 Ramsey Street:

Cincinnati, Ohio.

Bouton Foundry Co.,

FOUNDERS AND MACHINISTS,

CHICAGO, ILL.

Gas Works Apparatus,

PURIFIERS, CONDENSERS,

Bench Work

SPECIALS, LAMP POSTS,

SCRUBBERS,

Iron Roofs and Floors.

Plans and Estimates furnished for new works or extensions of old works.

1842. **DEILY & FOWLER,** 1890.
Laurel Iron Works.

Address, No. 39 Laurel Street, Philadelphia, Pa.

BUILDERS OF

GASHOLDERS,

Single and Telescopic.

HOLDERS BUILT 1884 TO 1888, INCLUSIVE:

- | | | | | |
|----------------------------|-----------------------------|---------------------------|--------------------------|------------------------|
| Newport, R. I. | Long Island City, N. Y. | Port Chester, N. Y. | Malden, Mass. | West Chester, Pa. (2d) |
| Portland, Oregon. | Macon, Ga. | New Rochelle, N. Y. | Paducah, Ky. | Lancaster, Pa. (3d) |
| Allegheny, Pa. (2d.) | York, Pa. | Salem, N. J. (3d) | Norwich, Conn. | Facony, Pa. (two) |
| Atlanta, Ga. (2d.) | Chester, Pa. | Omaha, Neb. (2d) | Seattle, W. T. | Mount Vernon, N. Y. |
| N.Y. City (Central Gas Co) | Hazleton, Pa. (2d.) | Lynn, Mass. (2d) | San Diego, Cal. | Binghamton, N. Y. |
| Lynchburg, Va. (2d.) | Staten Island, N. Y. | Little Rock, Ark. | Northern Gas Lt. Co., of | Concord, N. H. |
| Saylesville, R. I. | Saugerties, N. Y. | Irvington, N. Y. | New York, N. Y. | Dover, Del. (2d) |
| Rondout, N. Y. | Clinton, Mass. (Lan. Mills) | South Boston, Mass. | Westerly, R. I. | Calais, Me. |
| Atlantic City, N. J. | Chattanooga, Tenn. | Rye, N. Y. (2) | Willimantic, Conn | New London, Conn. (3d) |
| Augusta, Ga. | Galveston, Texas. (3d.) | Woodstock, Ont. | Montclair, N. J. | West Chester, N. Y. |
| Waltham, Mass. (2) | Omaha, Neb. | Malden, Mass. | Attleboro, Mass. | Bay Shore, L. I. |
| Mahanoy City, Pa. | Fort Plain, N. Y. | Staten Island, N. Y. (2d) | Santa Cruz, Cal. | Washington, D. C. |
| New Castle, Pa. | Brunswick, Ga. | Woodstock, Ont. | Erie, Pa. (2d) | |

WM. HENRY WHITE,

No. 32 Pine Street, - - - New York City.

ENGINEER AND CONTRACTOR FOR THE

Erection and Extension of Gas, Water, and Electric Light Works.

SOLE REPRESENTATIVE OF THE

MARTIN WATER GAS PROCESS.

Edison Incandescent and American Arc Electric Light Plants Installed.

Correspondence with Gas Companies contemplating extending or improving their Plants respectfully invited Plans and Estimates Furnished.

GAS COALS.

CANNEL COALS.

GAS ENRICHERS.

JAMES D. PERKINS. **PERKINS & CO.,** F. SEAVERN.
 228 & 229 Produce Exchange, New York.
 Cable Address, "PERKINS, NEW YORK." Post Office Box 3695, New York.

GENERAL SALES AGENTS FOR

The Youghioghenny River Coal Company's

OCEAN MINE YOUGHIOGHENY GAS COAL.

HON. W. L. SCOTT, Prest. M. H. TAYLOR, Vice-Prest.

This Colliery is located at SCOTT HAVEN, PA., in the center of the Youghioghenny Gas Coal District, and produces the ONLY RELIABLE YOUGHIOGHENY COAL for gas purposes. (See Map on p. 87 of this JOURNAL, Feb. 16, '85.)

POINTS OF SHIPMENT,

Locust Point, BALTIMORE. Pier No. 62, PHILADELPHIA.

Also, SOLE AGENTS for the

BRECKENRIDGE CANNEL,

OF KENTUCKY.

Within the past two years we have delivered this Cannel to over ONE HUNDRED COMPANIES IN THIRTY, THREE DIFFERENT STATES, and it is now in use in some of the large Gas Works

On the Continent and in South America,

where it successfully competes with the Australian Shale. It is the ONLY AMERICAN GAS CANNEL of sufficiently high grade to warrant EXPORTATION TO EUROPE AND SOUTH AMERICA, and it is the only economical substitute for OIL OR NAPHTHA. ONE GROSS TON will produce

10,000 Cubic Feet of 75 Candle Gas,	} equal to {	750,000 Candle Feet of Gas, and 26 Bushels of merchantable Coke weighing 900 Pounds
or 12,500 " " 60 " "		
or 15,000 " " 50 " "		

This is the ONLY GAS CANNEL that will produce a REALLY MERCHANTABLE COKE. It can be delivered in parcels of one carload or more to any point in the United States or Canada. Cargo shipments of any size required can be made from NEW YORK, PHILADELPHIA, BALTIMORE, or NEWPORT NEWS. Samples will be sent and particulars of price, etc., forwarded upon application to above address.

JAMES & WILLIAM WOOD,

Gas and Cannel Coal Contractors,

No. 40 St. Enoch Sq., Glasgow. No. 2 Talbot Court, London.

Proprietors of the BATHVILLE COLLIERIES (which produce the celebrated BOGHEAD CANNEL), Shields, Shieldmuir, Drumpeller, and other Collieries. This Firm offer

STANDARD CANNELS,

Unequaled as Gas Enrichers.

Also, WEST FAIRMONT GAS COAL, of W. Va.

Analyses, prices, and all further information furnished on application to

Agency for U.S., Room 70 Nos. 2 & 4 Stone St., N.Y. City.

The Standard Oil Company,

REFINERS OF

NAPHTHA AND GASOLINES.

ALSO MANUFACTURERS OF

A Special Grade of Naptha for Gas Companies

FOR ENRICHING COAL GAS.

Correspondence solicited.

No. 43 Euclid Avenue, Cleveland, Ohio.

To Gas Companies.

We make to order CAP BURNERS to burn any amount under a stated pressure. Send for samples.

Also, SERVICE CLEANERS, DRIP PUMPS, and STREET MAIN PROVING APPARATUS.

O. A. GEFRORER,

248 N 8th Street, Phila., Pa.

COKE CRUSHERS.

GAS COALS.

GAS COALS.

Newburgh Orrel Coal and Coke Co.

MINERS AND SHIPPERS OF

STEAM, SMITHING, AND GAS COALS,
Foundry and Crushed Coke.

Home Office, 33 S. Gay Street, Baltimore, Md.

J. HARRY LEE, President.

Shipping Wharves, Locust Point, Baltimore.

The Despard Gas Coal Co.,

MINERS AND SHIPPERS OF

DESPARD GAS COAL,

AND MANUFACTURERS OF

COKE.

MINES, Clarksburg, Harrison Co., W. Va.

WHARVES, Locust Point, Baltimore, Md.

OFFICE, 225 E. German St., " "

ROUSSEL & HICKS, } AGENTS. } BANGS & HORTON,
71 Broadway, N. Y. } 60 Congress St., Boston.

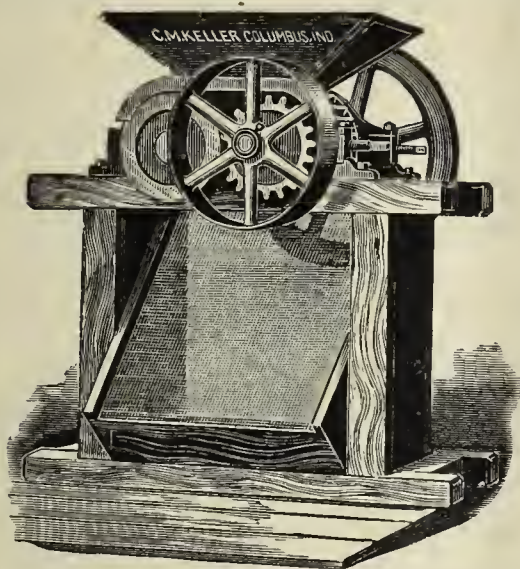

Keller's Adjustable Coke Crusher.

SIMPLE, STRONG, AND DURABLE.

O. M. Keller, Sec. & Supt. Gas Lt. & Coke Co. Columbus, Ind.

Correspondence Solicited.

King's Treatise on Coal Gas.

The most complete work on Coal Gas ever published.

Three Vols. Bound, \$30.

BOOKS.

DISTILLATION OF COAL TAR AND AMMONIACAL LIQUOR.

By GEORGE LUNGE. Price \$12.50.

A TREATISE ON THE COMPARATIVE COMMERCIAL VALUES OF GAS COALS AND CANNELS.

By DAVID A. GRAHAM. 8vo., Cloth. Price \$3.

Orders for these books may be sent to this office.

A. M. CALLENDER & CO.,

42 PINE ST., N. Y. CITY

THE PENN GAS COAL CO.

OFFER THEIR

Coal, Carefully Screened & Prepared for Gas Purposes.

Their Property is located in the Youghiogheny Coal Basin, near Irwin and Penn Stations on the Pennsylvania Railroad, and on the Youghiogheny River.

Principal Office:

209 SOUTH THIRD STREET, PHILA., PA.

Points of Shipment:

Pennsylvania Railroad Piers; Greenwich Wharves, Delaware River; Pier No. 1 (Lower Side), South Amboy, N. J.

Chesapeake & Ohio Railway Coal Agency,

FOR THE SALE OF THE

Superior Kanawha Gas Coals, Cannelton Cannel, Also, SPLINT AND STEAM COALS,

From the Kanawha and New River Regions, on the line of the Chesapeake & Ohio R'way.

C. B. ORCUTT, General Agent, - - No. 1 Broadway (Room 217) New York City.

FRANCIS H. JACKSON, Prest.

EDMUND H. MCCULLOUGH, V.-Prest.

CHAS. F. GODSHALL, Treas

H. C. ADAMS, Sec.

THE WESTMORELAND COAL CO.

Chartered 1854.

Mines situated on the Pennsylvania and the Baltimore and Ohio Railroads, in Westmoreland County, Penn.

POINTS OF SHIPMENT:

PHILADELPHIA, BALTIMORE, SOUTH AMBOY, N. J., WATKINS (SENECA LAKE), N. Y.

Since the commencement of operations by this Company its well-known Coal has been largely used by the Gas Companies of New England and the Middle States, and its character is established as having no superior in gas-giving qualities, and in freedom from sulphur and other impurities.

Principal Office, 224 South 3d St., Phila., Pa.

The American Gas Engineer and Superintendent's Handbook.

By WILLIAM MOONEY.

Consisting of Rules, Reference Tables, and Original Matter Pertaining to the Manufacture, Manipulation, and Distribution of Illuminating Gas.

350 Pages, Full Gilt Morocco.

\$3.00.

A. M. CALLENDER & CO., 42 Pine St., N. Y.

JOHN J. GRIFFIN & CO.,

Nos. 1513, 1515, 1517 & 1519 Race Street, PHILADELPHIA.
52 Dey St., NEW YORK. 75 N. Clinton St., (FRED. R. PERSONS, Mangr.) CHICAGO.

MANUFACTURERS OF

METERS FOR MEASURING GAS

IN ANY VOLUME.

Provers, Gauges, Registers, Etc., Etc.

EXPERIMENTAL APPARATUS FOR QUANTITATIVE AND QUALITATIVE ANALYSIS.

Careful and Prompt Attention paid to Repairing of all kinds of Meters and Apparatus.

Estimates Cheerfully Furnished.

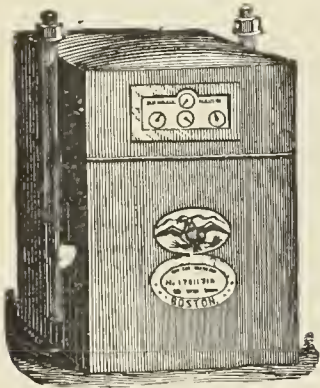

Dry Gas Meters.

With 40 years' experience and the best facilities for manufacturing, is enabled to furnish reliable work and answer orders promptly.

NATHANIEL TUFTS,

No. 153 Franklin Street, Boston, Mass.,

MANUFACTURER OF

DRY GAS METERS.

Station Meters of any Capacity.

Test and Experimental Meters, Pressure Registers, Pressure Gauges, Pressure and Vacuum Gauges.

METER PROVERS, PHOTOMETERS, STREET LANTERNS, ETC., ETC.

Patent Cluster Lanterns for Street Illumination.

HAROLD J. BELL.

BELL & JONES,

S. LEWIS JONES.

No. 12 North Ninth Street, Philadelphia, Pa. Works at Royersford, Pa.

MANUFACTURERS OF

GAS METERS, STATION AND EXPERIMENTAL METERS,
Meter Provers, Pressure Gauges, and All Other Gas Appliances in Our Line.

WE REPAIR ALL KINDS AND MAKES OF METERS, AND THE WORK GUARANTEED.

High Pressure Meters for Natural Gas, in Iron Cases, guaranteed to stand 300 lbs. Pressure.
Gas Cooking and Heating Stoves, Hot Plates, Cake Griddles, Waffle Bakers, Boiling Stoves, Laundry and Tailors' Iron Heaters. Hotel and Cafe Ranges a Specialty.

Correspondence Solicited.

Estimates Furnished.

A. HARRIS.

E. L. HARRIS.

J. A. HARRIS.

Established 1849.

HARRIS BROS. & CO.,

Twelfth and Brown Streets, Philadelphia.

Manufacturers of Wet and Dry Gas Meters,

STATION METERS, METER PROVERS,

EXPERIMENTAL METERS, SHOW OR GLAZED METERS,

Pressure and Vacuum Registers, Gauges, Photometers, Drip and Bell Pumps, Etc., Etc.

PROMPT ATTENTION GIVEN TO ALL ORDERS. METERS THOROUGHLY REPAIRED. ESTIMATES FURNISHED FOR STATION METERS OF ALL SIZES. CORRESPONDENCE SOLICITED.

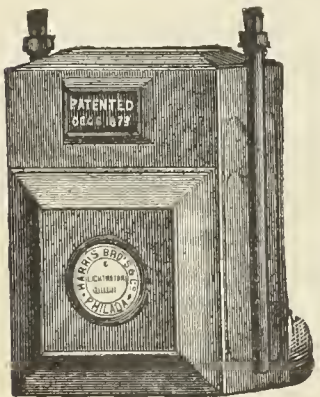

GAS METERS.

GAS METERS.

GAS METERS.

GEO. J. MCGOURKEY, Prest.

WM. H. MCFADDEN, Vice-Prest. (Phila.)

WM. N. MILSTED, Gen. Supt. and Treas. (New York).

WM. H. DOWN, Sec.

THE AMERICAN METER CO.

WET AND DRY GAS METERS.

PRESSURE REGISTERS.

METER PROVERS.

STATION METERS.

PRESSURE & VACUUM REGISTERS.

PORTABLE TEST METERS.

EXHAUSTER GOVERNORS.

PRESSURE & VACUUM GAUGES.

EXPERIMENTAL METERS.

DRY CENTER VALVES.

CRESSON GAS REGULATORS.

AMMONIA TEST METERS.

GOVERNORS FOR GAS WORKS.

MARSLAND WATER METERS.

BAR & JET PHOTOMETERS.

Manufactories:
512 West 22d St., N. Y.
Arch & 22d Sts., Phila.

GAS STOVES.
SUGG'S "STANDARD" ARGAND BURNERS,
SUGG'S ILLUMINATING POWER METER,
Wet Meters, with Lizar's "Invariable Measuring" Drum.

Agencies:
177 Elm Street, Cincinnati.
244 & 246 N. Wells Street, Chicago.
810 North Second Street, St. Louis.
222 Sutter Street, San Francisco.

HELME & McILHENNY,

(Established 1848.)

GAS METER MANUFACTURERS,

Nos. 1339 to 1349 Cherry Street, Philadelphia, Pa.,

WET AND DRY GAS METERS, STATION METERS, EXPERIMENTAL METERS, METER PROVERS,

Center Seals, Pressure Registers, Governors, Indicators, Photometers, and all other kinds of Apparatus for use in Gas Works.

FOULIS' PATENT STATION AND DISTRICT GOVERNORS.

REPAIRING DEPARTMENT.—We employ a special force of skilled workmen repairing meters of all makers.

WM. WALLACE GOODWIN, President and Treasurer.

E. STEIN, Vice-President.

H. B. GOODWIN, Secretary and Superintendent.

THE GOODWIN GAS STOVE AND METER CO.,

Successors to W. W. GOODWIN & CO.

1012, 1014 and 1016 Filbert St., Phila., Pa.

142 Chambers St., New York City.

76 Dearborn, St., Chicago, Ills

WALDO BROTHERS, Agents, 88 Water Streets, Boston, Mass.

MANUFACTURERS OF

DRY AND WET GAS METERS,

Station Meters (square, cylindrical, or in staves), Glazed Meters, King's and Sugg's Experimental Meters, Lamp Post Meters, etc., etc. Meter Provers (sizes 2, 5, and 10 feet), Pressure Gauges of all kinds, Pressure Registers, Pressure and Vacuum Registers, Pressure Indicators (sizes 4, 6, and 9 inch), King's Pressure and Vacuum Gauges, Dry and Wet Center Seals, Dry and Wet Governors, Exhauster Governors, Photometers of all descriptions. Letheby's Sulphur and Ammonia Test Apparatus complete. Also, Testing and Chemical Apparatus of all kinds, and of the most perfect description, for all purposes relating to Gas.

Manufacturers of the "SUN DIAL" GAS STOVES, for Cooking and Heating.

Goodwin's Improved Lowe's Jet Photometer.

Agents for Bray's Patent Gas Burners and Lanterns.

Special attention to Repairs of Meters and all Apparatus connected with the business. All work guaranteed first-class in every particular. Orders filled promptly.

G. B. EDWARDS, Manager, New York.

S. S. STRATTON, Manager, Chicago.

D. McDONALD & CO.,

GAS METER MANUFACTURERS.

(Established 1854.)

51 Lancaster St., Albany, N. Y.

34 & 36 West Monroe St., Chicago, Ill.

STATION METERS, EXPERIMENTAL METERS, METER PROVERS, PRESSURE & VACUUM REGISTERS, PRESSURE GAUGES, ETC.

Also STAR GAS STOVES, RANGES, and HEATING STOVES.

We use only the very best materials, and employ the most skilled labor, and by our long experience (36 years) and personal supervision of every detail we feel justified in assuring the public that our goods will give perfect satisfaction. Every Meter emanating from our establishment will bear the State Inspector's BADGE, and will be fully warranted by us. Our Annual and Calendar will be sent to Gas Companies upon application.

GAS INTO POWER,

BY THE

OTTO GAS ENGINE.

GAS POWER.—A Source of Revenue to Gas Companies ready to engage in Electric Lighting, building of Water Works, Electric Street Railways, etc.

Coal for producing Gas is less in amount than that for producing Steam, both being measured on an equal amount of work performed. And, further, with Gas,

50 to 90 per Cent. of Value of Coal is Returned

by sale of Coke and Tar, according to the market value of these products.

Labor for handling fuel is reduced, by its becoming centralized and confined to the gas house, and frequently has not increased after the addition of a power station.

With Gas Power, cost of fuel is strictly limited to the time of use.

MANY VALUABLE
AND RECENT
IMPROVEMENTS.

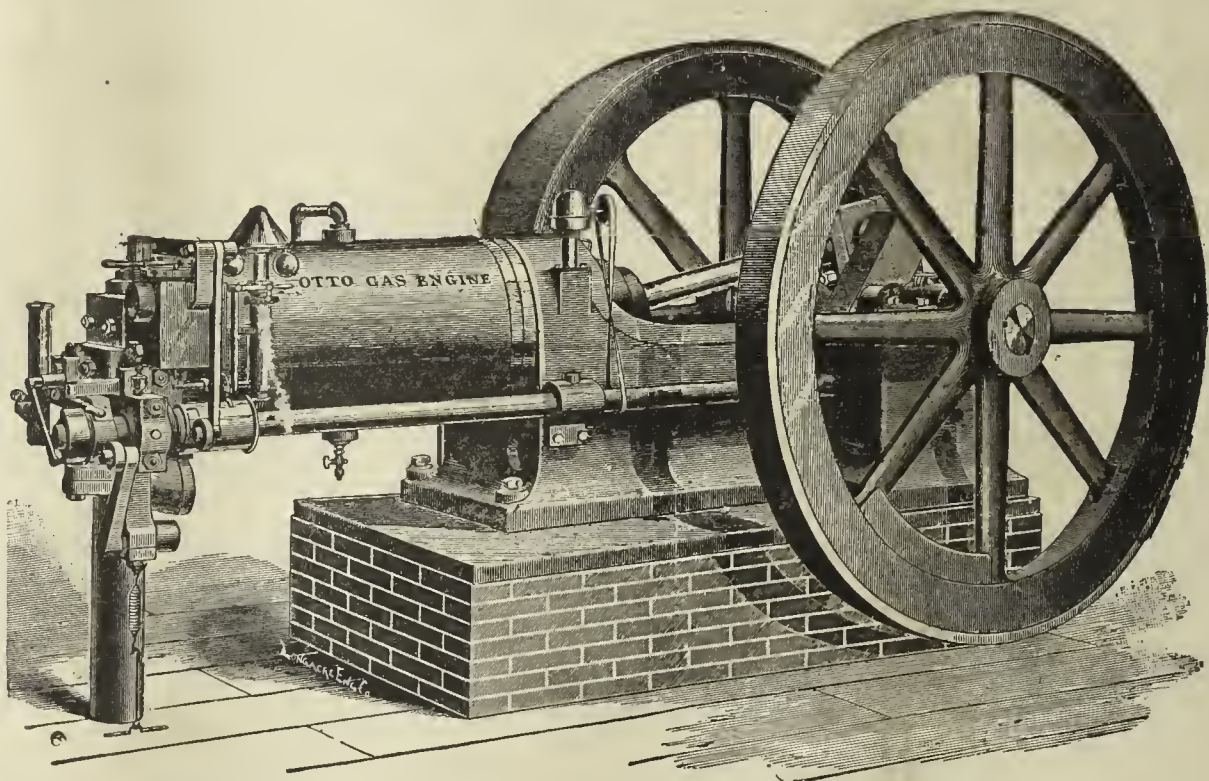

SIZES,
1-3 to 100
HORSE POWER.

Wherever Gas Companies tried Gas Power with Steam Power together in one Station, the use of Steam was subsequently abandoned or restricted, and Gas Power made to take its place.

Where Gas Companies adopt Gas Power for Electric Plants, Water Works, Sewerage, etc., they not only choose the most economical power for their use, but secure to themselves the numerous advantages of increased production, without increase of expense, and benefit thereby their entire manufacture. They induce consumers, by their example, to abandon Steam for Gas Power, and, by establishing special rates, make

Gas Power the Leading Power of To-Day,
AND SOLVE AT ONCE THE QUESTION OF FUEL GAS.

“Otto Gas Engine Works,”

SCHLEICHER, SCHUMM & CO.,

151 Monroe St. (Kent Building), Chicago.

33d & Walnut Sts., Phila.

NEW YORK AGENCY, 18 VESEY STREET.

THE AMERICAN

GAS LIGHT JOURNAL

REDMAN & KENNY, N. Y.

PUBLISHING OFFICE No. 42 PINE STREET

DEVOTED TO THE INTERESTS OF ILLUMINATION, VENTILATION, WATER SUPPLY AND DISTRIBUTION, & GENERAL SCIENCE.

VOLUME LII.—No. 19.
Whole No. 779.

NEW YORK, MONDAY, MAY 12, 1890.

\$3 PER ANNUM,
IN ADVANCE.

A. M. CALLENDER & CO., Proprietors. C. E. SANDERSON, Manager.
JOS. R. THOMAS, C. E., Editor. T. J. CUNNINGHAM, Asst. Editor.

ENTERED AT THE POST OFFICE AT NEW YORK, N. Y.
AS SECOND CLASS MATTER.

Published on each Monday of the year, at No. 42 Pine Street, N. Y.

Terms of Subscription, Including Postage.—For the United States and Canada, \$3 per annum. European countries, \$4.50 (19 shillings—22½ francs). All payments to be made in advance. Single copies, 10 cents.

Remittances should be made either by post-office order, registered letter, or bank draft on New York, payable to the order of A. M. Callender & Co.

Collections are invariably made directly from this office, for subscriptions, advertisements, etc. We have agents to solicit the same, but they are not authorized to receipt for money.

CONTENTS.

An Asterisk (*) denotes an illustrated article.

OFFICIAL NOTICE—

Western Gas Association..... 657

EDITORIALS—

Briefly Told..... 658

The Entertainment Programme for the St. Louis Meeting—Exit the Wakefield Manufacturing Company—Mr. Todd's Policy—Notes.

The Market for Gas Securities..... 658

Fields for Scientific Research..... 659

Gas Works for Yankton..... 659

*Leisner's Apparatus for Manufacturing Gas..... 660

*Terrace's Parallel Motion for Gasholder Guiding..... 662

Notes on Some Coals in Western Canada..... 662

On Testing Materials, by Paul Kreutpointner..... 663

The Construction of Gasholder Tanks..... 664

Coal Fields of the State of Washington..... 635

Preservation of Wood by Chemical Means..... 666

ITEMS OF INTEREST FROM VARIOUS LOCALITIES..... 667

Mr. Smedberg in Charge at Hamilton, O.—The Knapp-Campbell Gas Company—Improvements at Vineland, N. J.—The East River Gas Company—Killed by the Electric Current—The Council Agreed—Public Lighting, Columbus, O.—Mortgaging the Birmingham (Ala.) Plant—Cheaper Gas for Marquette, Mich.—Annual Meeting, Cumberland, Md.—To Fix Gas Rates at Toledo, O.—Electric Light is not a Manufactured Article—Public Lighting, Revere, Mass.—Public Lighting, New York City—Death of Mr. John Fullagar—Cities may not Manufacture Gas or Electricity—A Fraud in Cleveland, O.—Annual Meeting, Wilmington, N. C.—And Many Other Items.

CORRESPONDENCE—

Electric Lighting at St. Louis..... 669

[OFFICIAL NOTICE.]

Western Gas Association.

SECRETARY'S OFFICE, WESTERN GAS ASSOCIATION, }
QUINCY, ILLS., May 7, 1890. }

The Thirteenth Annual Meeting of the Western Gas Association will be held at the Lindell Hotel, St. Louis, Mo., on the 21st, 22d and 23d days of May. The hall in which the business sessions of the Association will be conducted is within the hotel building, is very commodious, quiet, and in every way excellently well adapted to our requirements. The hotel management has granted on this occasion the following rates:

For single room and board, \$2.75 per day; for room with bath, \$3.25 per day. These rates will apply to members in attendance, their families and visiting brethren. In this connection I am instructed by the Local Committee of Arrangements to give our members warning of the fact that in order to secure suitable accommodations, their rooms *must be engaged in advance*. Your Secretary has been in the habit of making an announcement to this effect with exceeding regularity from year to year, and just as regularly no one, or at least only very few, pays the slightest attention to the warning. The necessity of engaging quarters in advance, however, is in this instance very urgent. Now that the old Planters' House has been closed, the Southern and Lindell Hotels often have more business thrust upon them than they are capable of handling, and of late it has been no unusual occurrence for them to deny would-be guests admission, unless their rooms had been previously spoken for. But all of our members can be accommodated without the slightest jar or friction, if they will but take the trouble to address a line to the "Proprietor of the Lindell Hotel, St. Louis, Mo.," telling him the kind and price of room or rooms desired. This should be done at least one week in advance of the first day of the meeting.

In addition to the reduction in transportation rates granted by the Central Traffic Association, the Trunk Line Association has also joined in the movement. As the boundary of the latter Association extends as far east as the western border of the New England States, our Eastern friends will be enabled to avail themselves of the reduced fares.

I am authorized to state that Mr. R. D. Walsh, Chairman of the Local Committee of Arrangements, has kindly consented to take charge of all articles destined for the Gas Exhibit, and will cheerfully surrender a generous portion of his time to the interests of exhibitors. Communications, consignments of gas stoves, apparatus, burners—anything, in fact, intended for the Exhibit—may be directed to Mr. Walsh, in care of the Laclede Gas Light and Coke Company. Exhibitors can rest assured that not only will their wares receive careful handling and be displayed to the best possible advantage, but that they themselves will be accorded the most courteous treatment at the hands of Mr. Walsh and his efficient committee.

The "Paper List" for our Thirteenth Annual will be as follows:

- "Relative Value of Gaseous Fuels," by B. E. Chollar.
- "Effects of Natural Gas Competition," by James Somerville.
- "An Argument in Favor of the Adoption of a Uniform System of Estimating the Cost of Gas in the Holder," by George G. Ramsdell.
- "Impressions of British Gas Works," by George T. Thompson.
- "Mixed Gases," by E. G. Cowdery.
- "Wrought Iron, Cast Iron, or Steel—which is the Best Material for Street Mains?" by Eugene Printz.
- "What Policy Should the Gas Interest Adopt in Connection with the Approaching World's Fair?" by Walton Clark.
- "On the Abuse of the Patent System as Bearing on the Gas Industry, with a Remedy," by Frederic Egner.
- "The By-Products of Experience," by Allen R. Foote.

The attention of the Board of Directors is called to the fact that Section I., of Article VII., of our By-Laws reads as follows: "The Board of Directors shall meet as such at least once in each year, on the day preceding the annual meeting of the Association, at which time they

shall determine in regard to the propriety of the various papers, drawings, models, or other matters constituting the special order, being laid before the Association." The Board of Directors elected at our last meeting is composed of the following-named gentlemen, who are, therefore, particularly requested to assemble at the Association's headquarters on Tuesday morning, May 20, at 10 o'clock:

J. B. Howard, E. H. Jenkins, Z. T. F. Runner, John Gimper, C. W. Butterworth, E. G. Cowdery, J. S. Ambrose, J. W. Dunbar, and B. E. Chollar.

The social features of the Thirteenth Annual, as provided by the Entertainment Committee, will be as follows:

On Thursday evening there will be a grand moonlight excursion and supper on the Mississippi, the handsome steamer *Oliver Bierne* having been engaged for the occasion. A trip will be made up the river as far as the Chain of Rocks, giving a view of the new water works now in process of construction, and also of the recently completed Merchants' Bridge. On returning, the steamer will run down below Carondelet, affording a beautiful twilight view of the full 16 miles of the city's front along the Mississippi. Supper will be served, and there will also be music and dancing, the boat returning to the wharf at 10 o'clock.

On Friday, at 10:30 A.M., carriages will be in readiness at the hotel for delegates and their guests. A drive will be taken through the western portion of the city as far as the Fair Grounds, where a luncheon will be served at the Jockey Club House. After a series of entertainments, beginning at 2 o'clock P.M., which have been generously tendered by the Board of Directors of the Fair Grounds, parties wishing to take a drive through the parks may do so at their pleasure, in carriages provided by the committee.

Ladies accompanying delegates can obtain carriages at any time during Wednesday and Thursday for such purposes as they may desire.

From the above it will be seen that the time-honored custom of serving a banquet on the second night of our reunion will be departed from. This is an innovation which the committee feels assured will receive a hearty welcome from the "Toast-Responders;" and possibly from many others for the mere sake of a change, if for no other reason.

Application blanks, copies of our By-Laws, and any information not contained in these communications will be cheerfully furnished by

A. W. LITTLETON, Sec'y.

(Since writing the foregoing, your Secretary has received word that the lines operated by the Southern Passenger Association will grant the same rates as those which will be given by the Central Traffic and Trunk Line Associations, viz., one fare and one third for the round trip. These fares can be obtained on the certificate plan. Any railroad ticket agent within the territories of these three passenger associations will take pleasure in informing a member as to the steps that are required for securing these reduced fares. It is hoped that every delegate who can do so will avail himself of the reduction.)

BRIEFLY TOLD.

THE ENTERTAINMENT PROGRAMME FOR THE ST. LOUIS MEETING.—Secretary Littleton's current circular foreshadows with great distinctness the round of pleasure that is to be the portion of the Western's members and guests at the meeting to be held next week in St. Louis, and it will also be noted that the programme this year differs considerably from any that has so far been carried out. The time-honored banquet in formal state on the evening of the second day will not be held this year, and we are inclined to the view that the change, especially when we know that a most charming river trip is to be the enjoyable substitute, will be heartily indorsed by all. But one fear as to complete success can be entertained, and that fear is connected with the nature of the weather on the night of the 22d inst. Given good atmospheric conditions, and the outing on the Mississippi is bound to be a grand success. The balance of the programme for entertainment conjures up great expectations and reflects great credit on the originality and cleverness of those who have the preliminaries in charge. Another very satisfying announcement is found in the determination of the Southern Passenger Association to join in the offering of a reduced rate for passenger transportation. It gives us great satisfaction to be able to add that in every shape and manner the promise of a most successful meeting is assured.

EXIT THE WAKEFIELD MANUFACTURING COMPANY.—Following up our brief note of a week ago in respect to the defeat in the Rhode Island Senate of the scheme proposed by Mr. Addicks for the incorporation of the Wakefield Manufacturing Company, we may say that the matter came up on April 30th in the shape of a report from the committee

which had the matter under consideration, to indefinitely postpone the proposed grant. The Senate concurred in this, and a motion for reconsideration of that action was adopted. While this does not completely "kill the bill," in that it may be resuscitated before the next Senate, it may be looked on as extremely improbable that the measure, in its present framing, will ever be again considered. In the meantime the greed of the "Wakefield Company" schemers may actually deprive them of the "free assistance" that they so earnestly invoke in the nature of English capital. Without this latter sinew the paths of certain speculators or traffickers in "good gas situations in America" might have been much harder than they now are, and some of the "good gas situations" might still be in control of those who worked the situations up from poor to good ones. In any event, the leader in the April 22d issue of the *London Journal of Gas Lighting*, which is based on the Wakefield Manufacturing Company's application to the Rhode Island Legislature, sounds an alarm that tends to show that English capital, or rather its controllers, can make the separation between piracy and honest business practice.

MR. TODD'S POLICY.—When Mr. J. R. Todd resigned from the management of the Natick (Mass.) Gas Company to take charge of the gas plant at Middletown, N. Y., every one who knew that gentleman was certain that his success at Natick would be duplicated, at least, in his new field. And so it has been, not only duplicated, but excelled. This pleasant announcement is incited through our receipt of a circular which carries the intimation that the Middletown Gas and Electric Light Company, through Mr. Todd, had arranged for a repetition of the exhibition of gas cooking and heating stoves, similar to the display that was held by the Company in 1888 and 1889. Hearing is impressive, but illustration is the real way of making the picture. The Company hired a suitable apartment in the Dill Building, in Middletown, fitted up a complete exhibit of gas cooking, etc., stoves, and for one week (the display closed last Saturday) showed the beauties and value of cooking by gas to Middletown's housewives. Of course, we do not offer this as anything markedly out of the way, for many such exhibitions have been given in other places; but it takes courage to carry out plans of this kind in a locality like that of Middletown, for the "Managing Director" is apt to veto these on the ground that they cost too much. In any event, Mr. Todd must have all the credit for the results achieved in this direction in his present location, for when he took charge there the Middletown Company had *one* heating stove on its lines, and not a single cooker. Now, however, the lines carry gas to over 100 stoves, with the prospect that before the summer season of 1890 is ended that number will be returned at not less than 150. Again, as an evidence of Mr. Todd's careful guidance, from July 1st to December 31st, 1888, the increase in the Company's gas accounted for was 25 per cent. over the corresponding 6 months in 1887, and a further gain of 15 per cent. is shown in the same respect in the 6 months of 1889 over 1888. Surely this is the kind of management that ought to be appreciated by the proprietors of the property.

NOTES.—The stockholders of the Randolph Gas and Coal Company have assented to an increase in its capital stock of \$125,000. The present capitalization is \$200,000.—Manager Tracy, of the Poughkeepsie, (N. Y.) Gas Company, is availing himself largely of printer's ink for the popularizing of gas for purposes other than illumination. For instance, we are in possession of a recent issue of the *Evening Enterprise*, in which one and one-half columns are devoted to argument, figures and testimonials respecting the utility and convenience of gas cookers.—Manager L. C. Grapuer, of the Red Bluff (Cal.) Gas and Electric Light Company, is expending between \$4,000 and \$5,000 on betterments to the retort house plant. The electric light apparatus will not be added to.

The Market for Gas Securities.

The event of the week in city gas shares was the rise to par of Consolidated, which was bid for at noon to-day (Friday) at 100½. The figures thus given prove the position taken by us in respect to it. It will go higher, and not a better stock for investment purposes is at present on the market. Other city shares are strong and higher, too. Old Brooklyn gas sold on Wednesday of this week, at auction, at 116. Other Brooklyn shares are also in demand. The feature in out-of-town shares is the continued rise in Chicago gas, which is bid for at 58¾. Laclede common is at 24¾ to 25, and Bay State gas also moved up sharply. We have hitherto been quoting this stock on the basis of \$50—the stock is half stock—per share, when it should have been quoted, in accordance with our practice, on the \$100 basis. It is bid for at 79. The market in general is strong.

Fields for Scientific Research.

At the annual meeting of the Liverpool Physical Society perhaps the most striking feature of an extraordinarily good meeting was the address of the President, Prof. Lodge, who referred at length to the fields of greatest promise for scientific exploration. An abstract of the address is appended.

Running over some of these open paths we come across a fruitful field in the study of the effects of light on a great number of things. That light affected chemical combinations has long been known, and it is the foundation of photography, but we now find there is scarcely anything which light does not affect. It affects selenium enormously, bringing down its electrical resistance to half or one-third what it is in the dark; it may affect other bodies in a similar way. It affects metals, charging them electrically in a curious way, especially such metals as zinc. It seems to disintegrate or evaporate surfaces long exposed to it. It affects the electric field, causing a short spark to occur much more easily in ultra-violet light than in the dark. And quite recently, by Shelford Bidwell, it has been found to affect the magnetism of an iron rod in a sensitive condition. Of none of these phenomena has the investigation more than begun. Then, in the region of photography, there is a good deal to be done, not only in understanding the photographic process itself, but in photographing rays hitherto intractable. The photography of ultra-red rays a good way below the visible spectrum is, so far as I know, in the hands of Capt. Abney, who discovered how to do it. But others should now take it up and develop it. Celestial photography, with plates sensitive to obscure rays, might reveal a number of unsuspected and invisible semi cool worlds. The electric spark has lately been a favorite subject for photography, and much good work may be done by obtaining judicious photographs of lightning on fixed and on moving plates. A double-nozzled camera, with two plates, one fixed, the other spinning rapidly on an axis perpendicular to its plane (kept spinning at an approximately slow speed, say, clockwork), so that the same flash it depicted on both plates simultaneously, would give much valuable information. For some flashes a very moderate speed of rotation, or even a wiggling camera, suffices, but for others a speed of 30 revolutions a second gives an image apparently the same as if the plate were still. What is known as the Hall effect in various substances has not yet been exhaustively observed or measured. It has not even been observed as yet in insulators, though it ought, one would think, to be there; nor has its connection with the Faraday effect, the rotation of the plane of polarization of light by magnetism, been at all satisfactorily or finally made out; while its discrimination from, or assimilation to, certain known thermo-electric facts is at present hanging in suspense. Perhaps, however, these matters are rather too complex to be suitable for mention under present circumstances.

A simpler and more qualitative research is the effect of magnetism on a number of things. For instance, on living organisms. A person in a magnetic field is not known to feel anything. Reichenbach thought he had found people who were optically sensitive to a magnet, so that they could see whether an electro-magnet is excited or not. It may be so, but subsequent observation has not gone to confirm it. But, even if all persons are insensitive (by no means a likely conclusion without experimental proof), other animals may not be. Phosphorescent things—a glow-worm, or some of the luminous sea beasts of Dr. Herdman—may be fit subjects for experiment. How, again, does a gymnotus or electric eel behave in a powerful magnetic field?

I can imagine a fine field for a physicist to encamp on Puffin Island, under the auspices of the Biological Society, and bully some of the microscopic and other animals with electric and magnetic and optical appliances. Even if they declined to take any notice, the fact ought to be ascertained; but if any of them were properly sensitive, development of the fact might be surprising. Then, again, plants; sensitive and other muscular plants are well known to set up electric currents and to be under electric control; magnetism might be applied to plants also; and about their electric phenomena there is much more to work out. Heaps of experiments on plants and on germinating seeds could be made by an ingenious physical experimenter, and, though they might be more sluggish in their response than animals, some remarkable developments might ensue. A change of physical surroundings in the course of a few generations might bring about noteworthy changes of structure. Seeds growing under inverted circumstances as regards light have, I suppose, already been experimented on. I do not know. I am not familiar with the subject, and the biological suggestions I throw out are therefore vague. But this I feel, that so long as the origin of life is wrapped in mystery, experiments on the simplest form of protoplasm—subjecting it to a variety of kinds of circumstances,

electrical, magnetic, optical, thermal, mechanical, and chemical—may any day, though not perhaps for a few centuries yet, result in an astounding discovery, which will throw our present idea of evolution into the shade.

A number of experiments and observations can also be made on crystals and crystal formations by those who have suitable opportunities. The accidental formation of twin crystals, and the beautiful optical phenomena which develop themselves at the twinning surface, are matters of quite recent discovery, or, at least, of recent attention. So also is the perfectly astounding fact that a crystal, such as Iceland spar, for instance, can be mechanically twinned or pushed over into its perverted form by the pressure of a knife judiciously applied. Effects of magnetism on chemical action have now been discovered, and it is known that a piece of magnetized iron is less easily attacked by an acid than ordinary iron, provided, at least, the iron is pointed so that its lines of force are very diverging, or its field rapidly varying. But many other facts remain to be ascertained in connection with these subjects. The electrical properties of flame are only partially worked out, and their power of discharging static electrification has had fresh light thrown on it quite lately by some experiments of Worthington. The study of phosphorescent substances is yet in its infancy. Why should not a phosphorescent substance give out a really useful amount of light? Why is the process by which the glowworm maintains so brilliant a speck of illumination?

Many amateurs possess an induction coil, having, indeed, often made it themselves. Approximately the same number of amateurs do not know what to do with it when made. They use it to illuminate vacuum tubes, which they buy at a shop, nicely colored. Well, don't buy them, but make them, and omit the colors. Read the researches of Mr. Crookes, and other more recent investigations on the subject by Schuster, and Moulton, and Wiedemann and others, and you will find in the electrical phenomena of high vacuum an unlimited field for profitable experiment. More than this: A whole continent of practically unexplored territory has just been opened by the discovery of Hertz that electro-magnetic waves in air can be easily produced and detected. Some may know and some may not know of these brilliant investigations into the propagation of electro-magnetic waves. But any one with an induction coil, an empty room, and some bits of metal can repeat many of them. Any repetition of known experiments is the natural prelude to the discovery of new ones.

The Hertzian receiver is a microscopic spark gap. This serves, but it is by no means necessarily the best, as it is certainly not the most metrical method. Gregory has tried a kind of metallic thermometer with some success. In Germany, I hear, a kind of bolometer or wire resistance thermometer has been successfully used. Quite lately Fitzgerald writes me that a galvanometer in circuit with a simple wire makes these waves apparent. This will simplify their investigation very much. That is always the way. Once a thing has been done, hundreds of ways of doing it turn up. For instance, the telephone. The transmission of speech by electricity seemed a mighty achievement, and so it was; but now, almost anything will transmit speech—a flower pot full of cinders has been made to talk. The great electro-magnetic waves excited by any kind of electric discharge are now under easy control, and they can be reflected by mirrors, refracted by prisms, concentrated by lenses. They can be polarized and analyzed. Diffraction and interference effect can be detected in them. Everything optical has its counterpart in this new region, for they are to all intents and purposes light, as Clerk Maxwell predicted nearly a quarter of a century ago, from refined and abstract mathematical investigation.

The whole of this great field now lies open to the explorer, and only a few have entered it. Here and there a mathematician, here and there an experimentalist, is at work upon it, but there is plenty of room, and every fact is of interest. These electric waves have been obtained as long as 2,000 miles and as short as a foot; they can easily be lengthened, they cannot so easily be shortened. If shortened to the 10,000th of an inch they would affect the retina and be visible. At present they belong to the region of the infra-red. Whether they affect the human frame at all is unknown. Apparently they do not, but further experience may show that they do.

WESTERN capitalists are negotiating with the authorities of Yankton, Dakota, for the right to operate a gas works there. This place is on the left bank of the Missouri river at a point 61 miles west-northwest of Sioux City, and 140 miles north-northwest of Omaha. It is beautifully located on a level plateau, at elevation of 1,200 feet from sea level. The river is navigable for steamboats, and it is also reached by the Southern Dakota Railroad. Population, about 9,000.

Leisner's Apparatus for Manufacturing Gas.

On April 29th U. S. Letters Patent (No. 426,823) were granted to George Leisner, of Philadelphia, Pa., for an improved gas making apparatus, the rights for which were subsequently assigned to the United Gas Improvement Company, of the same city. The Leisner specification is as follows:

My invention relates to apparatus for generating water gas, and has for its object to provide a generator of improved construction whereby the gas may be driven off from the coal with which the generator is fed and saved more effectually and with better economical results than has heretofore been the case in apparatus with which I am familiar.

The novel features of my invention will be best understood as described in connection with the drawings in which they are illustrated, and in which Fig. 1 is an elevation in section of a water gas apparatus embodying my improvement; Fig. 2 is a section through the generator and the parts superimposed upon it on the line $x x$ of F. 1; and Fig. 3 is an enlarged view of the valve used to close the conduits $e e'$.

A is the generator, provided with the usual grate a to support the fuel, an air-blast conduit a' , leading into its lower part, a steam conduit a^2 , also leading into its lower part, a door a^3 at its bottom to per-

operative purposes the generation of gases in the retort and in the generator were totally independent of each other.

By referring again to the drawings, b^2 is a movable grate arranged, as shown, to extend across the retort b and afford a support for the coal inserted in it, and having a handle b^1 , by which it can be withdrawn in part or in whole, so as to let the fuel supported by it fall in part or altogether into the generator A .

b^3 is a valve extending across the retort b beneath the grate b^2 , and provided with a handle b^3 , by which it can be withdrawn in whole or in part at will. Its function is to close the communication between the generator and the retort. The use of the movable grate and valve enables me to entirely close the retort chamber b with respect to the generator when fuel gas is being generated therein, such gases passing through pipe C' into the chamber C , surrounding the retort, and escaping through the conduit D , while the gases generated from the coal in the retort b escape through the conduit E , and can be saved from and without admixture with fuel gas, while at the same time as soon as the generator begins to manufacture water gas by merely withdrawing the valve b^3 such water gas will pass up into the retort b , mingling with the gases driven off from the coal and passing with such gases through conduit E to such point of storage, use, or further treatment as may be de-

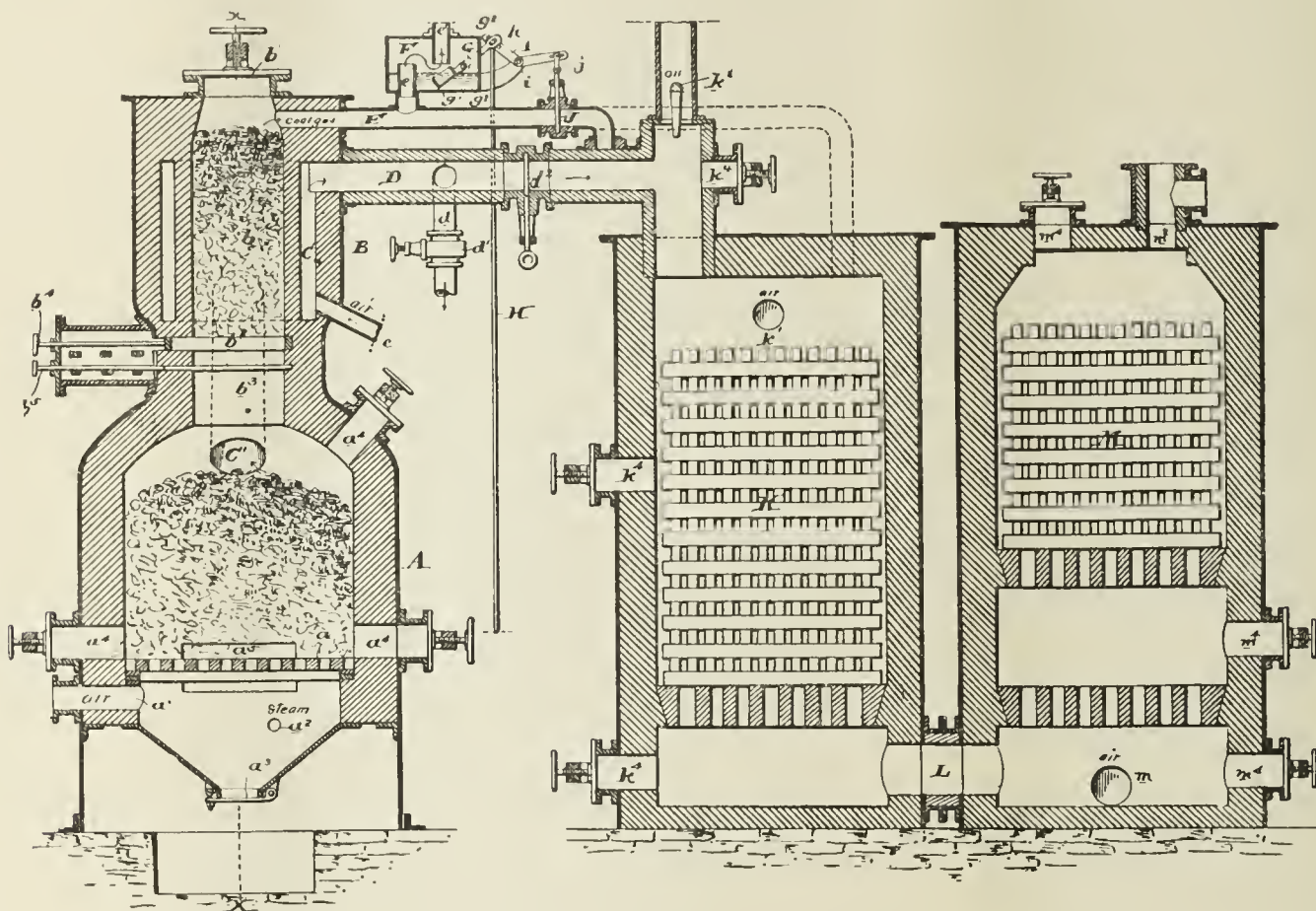

Fig. 1.

mit the exit of ash from time to time, man-holes a^4 conveniently arranged, and stoking-hole a^5 . Upon the top of the generator is supported the structure B , containing a substantially vertical retort b , situated immediately above and in free communication with the generator. This retort is provided at its top with an opening, closed by lid b^1 or in any convenient way, through which fuel can be introduced from time to time. A chamber C is also formed in the structure B , so as to surround the vertical retort b , and this chamber C is placed in communication with the generator in any convenient way, as by a conduit or pipe C' . A conduit D leads off from chamber C to a system of regenerative superheaters or fixing chambers (indicated in the drawings at K and N), and a conduit E also leads off from the retort chamber b .

All of the above-mentioned parts of the apparatus are substantially shown in various patents, publications, and structures with which I am familiar; but in all such older structures the fuel inserted in the vertical retort is supported by and forms a continuous body with the fuel in the generator, and no provision is made for passing water gas through the vertical retort, or for saving all of the gases driven off from the coal. I am aware, also, that coal has been fed through vertical retorts externally heated, with closed bottom and gas passages leading from them, and that such retorts have been arranged in convenient proximity to generators, so that the coke formed in them could be from time to time withdrawn and fed into the generator; but in such cases, also, no provision was made for passing water gas through the retort, and for all

sired. Preferably I provide a valve c' in the passage leading from the generator to the chamber C , so that during the generation of water gas the passage may be closed to compel all the gases to pass through the retort b , or partly closed, so that the greater part of the gas will pass through said retort chamber and a small portion into the chamber C . I prefer also to lead an air-blast pipe c , Fig. 1, into the chamber C , so that the gases passing into it may be ignited and combustion kept up around the retort b . Where it is desired to maintain combustion in the chamber C during the generation of water gas, as well as during the generation of fuel gas, I provide escape pipe d in conduit D , and a valve d^2 to close said conduit, so that the products of combustion can be led off through the passage or escape d . A valve d' should be inserted in the conduit d , so that it can be closed whenever the main conduit D is open.

My invention is intended for use in connection with the ordinary system of regenerative fixing chambers by which water gas, together with other rich carbonaceous gases or vapors, are converted into a fixed gas. When so used, the conduits D and E both lead into the fixing chambers, as shown in the drawings. The conduit E may lead directly into the fixing chambers, as is shown by the dotted continuation of said conduit, or it may lead into the conduit D , as is shown by the full lines. In this combination I provide a conduit $e e'$, leading from conduit E , and valves to control this passage and to control the conduit E on the farther side of this passage. As shown in the drawings, the pipe e leads into the bottom of box F , through the top of which the continuation e'

of the conduit, consisting of pipes $e e'$, also leads. A lever G is secured to the end of a shaft g , which passes through the wall of the box F , and has secured to it on the inside of the box an arm g^3 , holding a cup g' , the said cup arranged directly beneath the open end of the pipe e' . The lower part of box F is filled with tar or some material of like nature, so that when the lever G is thrown up and the cup g' down it will fill itself with tar, which, when the lever is pulled down and the cup pulled up, as shown in Fig. 3, will make a seal on the bottom of the pipe e' . On the outer end of the lever G a slot g^2 is formed, through which and a similar slot in a pivoted lever I a pin h , attached to a rod H , passes. The lever I is pivoted at i , and attached, as shown in Fig. 1, to a link j , extending from a sliding valve J , situated in the conduit E . The above described arrangement is such that the valve's conduit $e e'$ and conduit

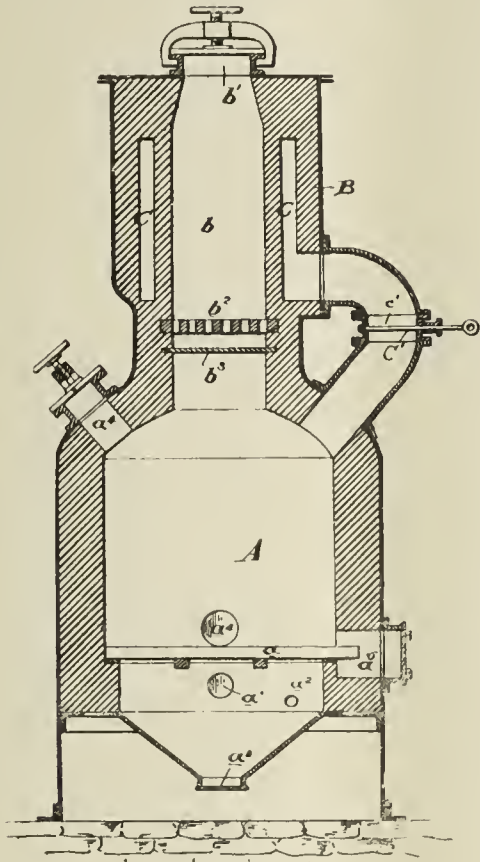

Fig. 2.

E are simultaneously actuated in opposite directions—that is, so as to either open the conduit $e e'$ and close the conduit E , or to open the conduit E and close the conduit $e e'$.

The regenerative fixing chambers or superheaters (shown to the right of Fig. 1) are of the common character in water gas apparatus, and need not be particularly described. The gases pass from the generator into the top of the superheater K , where they mingle in the combustion chamber at the top thereof with air introduced through the gas passage k' , the burned gases passing down through the brickwork and out from the bottom of the chamber through passage L into a combustion chamber at the bottom of the superheater M , where more air is introduced through the gas pipe m' , and the burning gases pass upward through the brickwork and out at the passage m^2 , from which connection is made to any convenient stack which will carry off the products

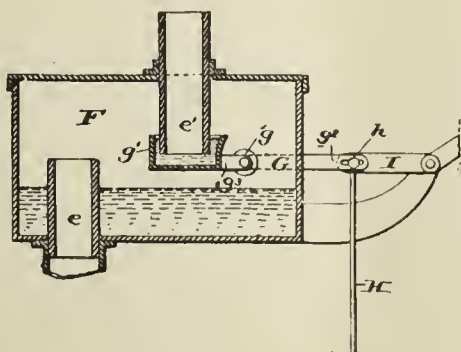

Fig. 3.

of combustion. When the generator is sufficiently ignited and the superheater sufficiently hot, steam is passed into the bottom of the generator and the water gas resulting introduced into the superheaters in the same way as the fuel gas previously introduced. Air, however, is of course shut off from the superheaters, and in general, oil is introduced, as by pipe k^2 , to be vaporized and combined into a fixed gas with the water gas by the action of the superheaters, the gases being drawn off fin-

ally through m^2 and conveyed to a point of storage or use. The parts marked k^1 and m^1 in the drawings are manholes to permit convenient access to different parts of the superheaters.

My preferred mode of operating the improved apparatus is, after having properly charged the generator with fuel, to thrust the grate b^2 across the lower portion of the retort b and close the valve b^3 . I then charge a quantity of coal into the retort b and close the charging orifice at the top. The air blast is then or previously, if desired, turned on in the generator, and the fuel gases pass through the conduit C' , the valve c' of which is open, into the chamber C , into which chamber, also, air is introduced through the blast pipe c , so that combustion shall ensue around the retort b . The air introduced at this point, however, need be but small in quantity, as it is not desired to consume any large proportion of the gases in the chamber C , which, together with the retort b , can be heated to a considerable and essential degree even without combustion in chamber. The gases leave the chamber C through the conduit D , and are delivered by it into the regenerative chambers K and M , in which they are completely burned, in order to heat the chambers for subsequent operations. While this is going on the conduit consisting of the pipes $e e'$, leading from pipe E , is opened and the pipe E closed in advance thereof, as shown in Fig. 1, so that all gases distilled from the coal in the retort b pass through the pipes $e e'$, which convey them to a convenient receiver. (Not shown in the drawings.) This operation is continued until the fuel in the generator is thoroughly ignited and the superheating chambers heated to a high degree. The air blast is then shut off from the generator and steam introduced, the valve b^3 opened, the conduit $e e'$ closed, and the valve J in the conduit E opened. The water gas generated in generator A can then pass upward through the retort b , and out of said retort it passes, together with coal gases driven off from the coal, into conduit E , whence it is delivered, either directly or by means of a connection with conduit D , into the regenerative fixing chambers or superheaters, through which it passes and is finally delivered to a receiver (not shown), oil, if desired, being injected to enrich the gases. Preferably I also close the valve c' when making water gas, so that no gases will pass from the generator into the chamber C . If desired, however, the valve c' can be adjusted so that a small portion of the water gas will pass from the generator into chamber C , and, the air blast through c being continued, combustion will ensue, or, rather, be maintained, around the retort b . Where this is done it is necessary, in order to prevent admixture of products of combustion with the gases passing into the fixing chamber, to provide a take-off pipe d in conduit D , and a valve d^2 by which the conduit can be closed on the farther side of the take-off. A valve d' is of course provided in the take off pipe d , so that it can be closed when the valve d^2 is opened.

If desired, a portion of the water gas may be passed through the conduit C' , chamber C , and conduit D , while another portion is passing through the retort b , as already described. All that is necessary is then to cut off the air blast through c , so that no combustion will take place in chamber C .

The inventor makes the following claims for originality of design :

1. In a gas generating apparatus, a water gas generator A , in combination with a substantially vertical retort situated above it and opening freely therein, a feed opening at the top of the retort, a movable grate b^2 , arranged in the retort to sustain the coal, a valve b^3 , arranged in the retort to control the communication between it and the generator, a conduit leading from the retort, a chamber C , communicating with the generator and surrounding the retort, and a conduit leading from the chamber C .

2. In a gas generating apparatus, a water gas generator A , in combination with a substantially vertical retort situated above it and opening freely therein, a feed-opening at the top of the retort, a movable grate b^2 , arranged in the retort to sustain the coal, a valve b^3 , arranged in the retort to control the communication between it and the generator, a conduit leading from the retort, a chamber C , communicating with the generator and surrounding the retort, an air supply pipe c , leading into chamber C , and a conduit leading from the chamber C .

3. In a gas generating apparatus, a water gas generator A , in combination with a substantially vertical retort situated above it and opening freely therein, a feed-opening at the top of the retort, a movable grate b^2 , arranged in the retort to sustain the coal, a valve b^3 , arranged in the retort to control the communication between it and the generator, a conduit leading from the retort, a chamber C , communicating with the generator and surrounding the retort, a valve controlling the communication between chamber C and the generator, an air supply pipe c , leading into chamber C , and a conduit leading from the chamber C .

4. In a gas generating apparatus, the combination of a water gas generator A , a substantially vertical retort b , situated above the generator,

having a feed-opening at its top, and opening into the generator at its bottom, a movable grate b^2 to sustain the fuel in retort b , a valve b^3 , to regulate the communication between the generator and retort, a chamber C , surrounding the retort b and connected with generator A , a valve arranged to close and regulate the connection between the chamber C and generator A , a conduit D , leading from chamber C to regenerative fixing chambers, a conduit E , leading from retort b to said fixing chambers, a passage e , leading from conduit E , a valve controlling passage e , a valve controlling conduit E on the further side of passage e , and one or more regenerative fixing chambers connected to conduits D and E .

5. In a gas generating apparatus, the combination of a water gas generator A , a substantially vertical retort b , situated above the generator, having a feed opening at its top, and opening into the generator at its bottom, a movable grate b^2 , to sustain the fuel in retort b , a valve b^3 , to regulate the communication between the generator and retort, a chamber C , surrounding the retort b and connected with generator A , an air supply pipe c , leading into chamber C , a valve arranged to close and regulate the connection between the chamber C and generator A , a conduit D , leading from chamber C to regenerative fixing chambers, a conduit E , leading from retort b to said fixing chambers, a passage e , leading from conduit E , a valve controlling passage e , a valve controlling conduit E on the further side of passage e , and one or more regenerative fixing chambers connected to conduits D and E .

Terrace's Parallel Motion for Gasholder Guiding.

In returning to the subject of gasholder guiding the *London Journal* says:

In the *Journal* for Jan. 8 of last year an illustrated description was given of an arrangement devised by Mr. James B. Terrace, of Brechin, N. B., for guiding gasholders by means of sets of spur wheels keyed

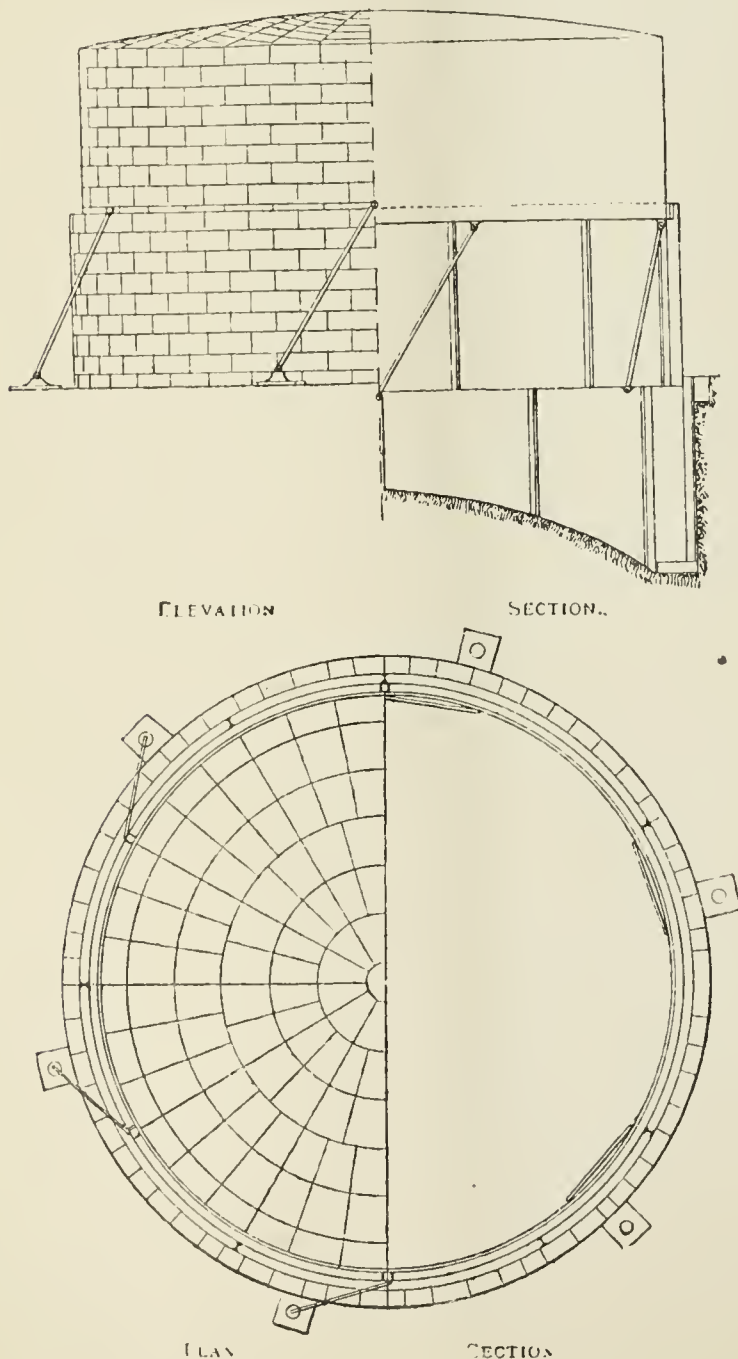

upon spindles long enough to reach the distance at which the guide columns are ordinarily placed round the tank of a gasholder. Mr. Terrace now sends to us for publication a drawing representing a double-lift gasholder, 60 feet diameter (the inner lift 58 feet), each lift being 18 feet

deep, the working movement of which is controlled by means of a number of long connecting links situated at regular intervals round the tank, instead of the ordinary guide-framing. A model of the arrangement has, it is said, been made—2 feet in diameter, with each lift 8 inches deep—and is found to work very satisfactorily indeed.

One-half of the drawing is in section, showing the inner lift connecting links *inside* the holder. One end of each link works into a bearing fixed on the bottom curb of the inner lift, the other end working into a bearing fixed on the bottom curb of the outer lift of the gasholder. These links, six in number, control the action of the inner lift only; and when the holder is being filled one end of each link rises from the horizontal to an angle of 60° , and remains at this angle as long as the two lifts are cupped. The other part of the drawing is not in section, and shows the outer lift connecting links *outside* the holder. One end of these links works into bearings fixed on the bed plates anchored on the ground outside the stone coping of the tank. The other ends work into bearings fixed on the top curb of the outer lift. These links—also six in number—control the action of the outer lift; and when the holder is being filled one end of the links rises from the horizontal to an angle of 60° , when it is filled to its utmost capacity.

In addition to the ordinary working of the gasholder, the links cause a rotary or side-way motion to take place. All the bearings to which the links are connected, therefore, require to be on the double-joint or ball-joint principle. With this side-way motion of the holder, the bottom curb guide rollers could, however, be dispensed with, as the points of contact deviate in the circuitous path along the upright guides.

The controlling links may be placed otherwise than described above; and in the case of a three-lift holder, two tiers could control the three lifts—one set being used for the inner lift only, and the other set for the second and outer lift. The links for the latter two lifts would be connected to bearings fixed on the top curb of the second lift, the other ends working into bearings fixed on bed plates or columns anchored on the ground outside the stone coping of the tank.

Mr. Terrace claims that, when these controlling links are placed outside the holder, they not only keep it in proper equilibrium during its working movements, but act as strong supports. While some of them are in tension, the others are in compression; and so they relieve the bottom curb of the holder of a large amount of the strain which, in the case of some recent inventions, it is called upon to bear.

Notes on Some Coals in Western Canada.

[Abstracted from a paper read by Mr. Wm. Hamilton, F.G.S., at the Ottawa meeting of the Am. Inst. M. E.]

With the exception of the Vancouver Island coal, all the Western coal fields owe their present development to the completion, in the autumn of 1886, of the Canadian Pacific Railroad. While it could not be expected that a very great deal could have been accomplished in three years, enough has been done to pretty thoroughly establish the coal bearing areas and their correspondence with those which have been developed to the south of the boundary along the lines of the transatlantic railroads in the United States.

This summer I visited some of the important developments in the coal areas of Washington Territory, largely with the object of being better able to appreciate the corresponding coal bearing areas in British Columbia to the north.

In Western Canada, coal bearing rocks have been found in three zones.

1. In the plains to the east of the Rocky Mountains and in the eastern flanking ranges, the coal occurs in the Cretaceous formation (including the Laramie).

2. In the interior plateau of British Columbia, the coal is found in the Tertiary formation.

3. On the coast of British Columbia, Cretaceous and Tertiary rocks are found carrying coal, and on the Island of Vancouver the well-known Nanaimo coal has been worked for years in the first-named formation.

In all of these zones the coals vary from lignites up to higher grades, the factor determining quality being the amount of pressure to which they have been subjected. The intensity of this pressure is generally shown by the disturbance which the coals exhibit, and, in many cases, is almost directly in proportion to the distance of the deposits from mountain ranges. This seems to be also the opinion expressed by Mr. Bailey Willis in connection with his census report on the coals of Washington. It has been elsewhere stated that super-imposed strata has been thought to have been an important factor in these changes; but my observations for several years in all these areas lead me to the conclusion that it is

pressure alone from distortion and upheaval that has altered these Western coals into the many varying grades in which they are found to exist.

In the first zone an enormous amount of coal occurs in the territory between the western borders of Manitoba and the Rocky Mountains. I shall merely note some of the seams, which are reached by rail, as examples of the character of the coals in the area mentioned. In the plains they are all lignites, changing to a high grade lignite at the Galt mines (which are reached from the Canadian Pacific Railroad by a branch railroad 110 miles long), into a bituminous coking coal at the Bow River mines (where a 7-foot seam cuts across the main line of the Canadian Pacific Railroad), and finally the maximum result of the metamorphic influence is reached in the Cascade Valley, where the pressure of the mountains, on both sides of the Cretaceous trough, has altered the coal which it contains into an anthracite.

The following analyses, passing from east to west, convey some idea of the types of these coals :

TABLE A.
Eastern Zone.

	a.	b.	c.	d.	e.
Water.....	20.54	10.35	6.50	4.41	0.71
Volatile combustible matter.....	33.26	34.40	38.04	40.32	10.71
Fixed carbon.....	41.15	39.61	47.91	48.27	80.93
Ash.....	5.05	15.64	7.55	7.00	7.57
Total.....	100.00	100.00	100.00	100.00	100.00
Coke.....	None.	None.	None.	Good.	None.
Approximate distance from mountains, miles	234	128	36	28	0
a.—Medicine Hat, lignite (Geological Survey), fair coking.					
b.—Crawfoot, “ “ “ “					
c.—Galt, “ “ “ “					
d.—Bow River mines, bituminous, “ “					
e.—Cascade Valley, anthracite, “ “					

In the interior plateau of British Columbia lignite and coal have as yet been found in only a few places. The following are the only occurrences yet discovered worthy of notice :

At Princeton or Allison's some 20 feet of alternating lignite and shale seams occur, lying at a gentle dip. The lignite can be obtained of a workable thickness, but the greater part of the bed is too much mixed with shale. The character of the lignite, as indicated by the analysis, is that of an inferior coal.

The lignite found at Marble Canyon, Hat Creek, is of a better description, as shown by the analysis. It is said to be of very considerable thickness. I did not think the quality sufficiently good to justify a visit to the place, which has been described in the Reports of the Geological Survey.

At Kamloops, close to the Canadian Pacific Railroad, coal of a very fair bituminous character has been found; but as yet, seams of only about a foot in thickness have been opened up. The vicinity is being tested by a shaft.

In the Nicola Valley, some 40 miles from the railroad, a seam of bituminous coal, about 5 feet in thickness, has been exposed. This coal has been subjected to a greater amount of metamorphic influence than any yet discovered in this zone. It lies adjacent to a mountain, which is probably a result of the disturbance that has altered it into a good coking bituminous coal.

TABLE B.
Interior Zone.

	a.	b.	c.	d.
Water....	15.75	8.60	6.26	36.065
Volatile combustible matter	35.40	35.51	39.97	
Fixed carbon.....	41.45	46.84	48.22	
Ash.....	7.40	9.05	5.55	
Total.....	100.00	100.00	100.00	100.000
Coke.....	None.	None.	Fair.	Very good.
a.—Allison's lignite.				
b.—Hat Creek lignite (Geological Survey).				
c.—Kamloops, bituminous.				
d.—Nicola, bituminous (Geological Survey).				

On the Pacific coast zone, on the main shore, there has as yet been located a very small amount of coal and lignite, in the districts which correspond to the large areas developed along the Puget Sound to the south of the international boundary. And, as has been ascertained to the south of the line, the coal which has been found near the coast is merely a lignite, but that which occurs inland, near the Cascade Range, has

been altered into a bituminous coal. A sample of the latter type is found in a 2-foot, somewhat dirty bed of coal, which has been opened on the slope of Sumas Mountain. Still further inland, the cretaceous conglomerates occur near Chillawack, but all the coal which they have so far been found to contain consists of a few small masses forming part of the conglomerate, and some very thin strings of a coaly matter. The analysis from the above-mentioned Sumas Mountain seam is as follows:

Analysis of Sumas Mountain Coal.

Water.....	4.62
Volatile combustible matter.....	35.68
Fixed carbon.....	42.00
Ash.....	17.70
Total.....	100.00
Coke.....	Fair.

On Testing Materials.

Mr. Paul Kreutpointer, of Altoona, Pa., writing in a contemporary, considers that the financial benefits of testing materials manifest themselves in the decrease of supplies required for a given purpose. But it performs also an educational mission of considerable magnitude by forcing the consumer as well as the producers to acquire and exercise thought, skill, knowledge, care and attention. Testing of materials has become a special branch of science and a profession on account of its importance as an economic factor in the industrial world. No engineer can claim thoroughness in his profession who does not possess at least a fair knowledge of the properties of metals and the principles of testing them. Engineers have frequent occasion, in the absence of time or proper appliances, or both, to make what may be called emergency or field tests. Knowledge of the structure of metals and the effects of heat and work on the same are prime requisites to success in testing, handling and working metals. A designer may be a genius in mathematics, yet his work will be deficient in value at times if a text book is the only source of his metallurgical wisdom.

Quality of Metal.—Since materials like iron and steel are apt to vary in quality chemically and physically, testing serves two objects; it must be descriptive as well as comparative. By descriptive testing is meant to obtain, by a simple tensile, bending transverse or other test, a brief description of those qualities of a metal which are supposed to indicate its fitness for a given purpose in everyday service. For instance, the result of a tensile test made on a bar of iron taken at random from a lot of, say, two tons, will give us a sufficient description of the qualities of this particular lot of iron to enable us to consider that iron fit for use in car work. We are not the least concerned in this case how this iron compares in quality with link, stay-bolt or chain iron. As soon as we push our inquiry to the point, how does this metal compare with some similar metal as to quality or usefulness, then testing becomes comparative in intent and purpose? Comparative testing is essentially the basis of calculations of safe stresses and the designing of structures.

What is Quality?—The work of investigating and testing materials would be simple if conclusions could be drawn from one quality as to all the other qualities and properties of a metal. Unfortunately this cannot be done, as our present knowledge of the properties of metals is still too limited in that direction. Hence, we are confined in our investigations to the slow and often expensive work of comparative testing whenever the question as to the better quality of a metal is raised. The qualities and properties of metals are determined by their chemical composition and the manner and extent of mechanical treatment.

The farther a metal has been removed from its original raw state, the more numerous the manipulations it underwent through heating and cooling, hammering and rolling, the more complex has the nature of this metal become. To ascertain the respective qualities and properties thus imparted or acquired, chemical analysis or physical testing is resorted to. The latter may include tensile torsion, bending, transverse, crushing, shearing, drop hammer, nicking or fatigue test, including also etching and microscopic examination. Before making use, however, of any or all of these means to ascertain the quality and properties of a given material, it is well to determine beforehand whether the result obtained shall be merely for the purpose of general information, or whether it is to be applied to any definite purpose, and thus the work done be of relative value. The quality or quantities so obtained are the relative qualities of materials, since those qualities bear a close relation to the work we expect the metal to perform. On the contrary, if the object of testing is merely to gain general information, without its application to useful work, we ascertain the absolute quality of a metal and nothing more. In other words, we learn that a given piece of metal

can carry a load of so many thousand pounds or stretches so many per cent. in a given length before rupture takes place. This then is the absolute quality of a material.

How to Test and What to Test.—Next in importance to the understanding of the import of testing is the knowledge how to test and what to test. To inquire into the tensile strength of metal when we ought to know its torsional resistance or transverse deflection under a given load is obviously erroneous, and if the result is applied to practical purpose, may result in disaster. Or again, an elaborate tensile test is made where a cheap and quick bending test would answer all the purposes of a test. In this or similar cases no harm may result, but testing thus becomes a very expensive luxury. An example of the misapplication of the principle of testing as a guide to quality in the absolute groove or marine test section still prescribed by the Treasury Department as a measure of quality for boiler steel on river steamers. Only thorough knowledge of the properties of metals and of the effects of the form of test section on the result will prevent a misapplication of the economic principle of testing or the retention of antiquated usages and specifications. Wherever testing is carried on as a routine work on a large scale there will necessarily also be done a considerable amount of special and comparative testing. Under such circumstances the question of what to test assumes considerable importance on account of the cost of preparation of test-pieces, help, wear and tear of machinery and possible delays to the service. It would be a mistake to test, therefore, material which may be subject to no strain, perhaps has to carry its own weight only, and might even serve its purpose better if the material did not stand specification, because it would then be too hard. Zeal or desire to appear scientific, want of confidence in the ability or judgment of subordinates or a natural tendency to express everything in mathematical formulas and figures will often be the cause of what might be called "surplus" testing. In all such cases of unnecessary testing the result of the work done is equal to ascertaining the absolute quality of a material—a result which, as explained before, has no practical value.

Value of Testing.—In dealing with so complicated a subject as metallurgy and the products of metallurgical processes, it is essential to success that we look at the question of the value of testing not only in its scientific aspect, but also consider it in the light of purely a business transaction. The aim must be to make money through the medium of testing by saving waste with the least expenditure of money. The employment of cheap and incompetent labor or antiquated, unreliable machinery and appliances, will not do it, however. To try and apply a hard and fast rule, or, in other words, fit the conditions of the service and the qualities of materials to the specifications, is equally erroneous. Like the merchant who watches the quotations of the market, so the one in charge of specifications must watch the changes in methods of producing metals, in a general way at least. Division of labor, for instance, and specialization of product are as powerful factors to success nowadays in a steel mill as in a machine shop. As a natural consequence the product of a mill for a given grade, be that grade high or low, is remarkably uniform during long periods of time. Division of labor makes the furnaceman as much an adept in selecting and handling raw materials as the machinist in turning or planing certain shapes. On that account a manager hesitates to change men from one furnace to another. This fact can be made use of to reduce the cost of testing since it permits the reduction of the number of test pieces. If six test pieces represent the qualities of a heat or a day's work as well as five times that number it is certainly money in one's pocket not to test more than six pieces. There are other reasons besides which strengthen the position here taken. Some of the highest authorities on testing have long since argued that, as the elastic limit of material is its true measure of value in regard to its ability to do useful work, therefore the testing of metals to their ultimate strength and elongation is of no particular value, because no engineer ever expects to see the structures break which he designed. The only merit of the present method of testing up to ultimate strength and elongation is the simplicity of performing such tests.

On the other hand, the argument is advanced, and with good reason, that the amount of "commercial" testing to be done daily in the test department of a large concern, be it a steel mill, railroad, shipyard or bridge works, prevents the introduction of the method of taking the elastic limit as a routine work. A way out of this difficulty might be found in the fact alluded to above, that specialization tends to uniformity of product. Sometimes it also tends to deterioration of quality of product, but with this question we are not now concerned, except to say that in this case also the above fact holds good, for it has been found that material deteriorated in quality is equally uniformly bad. Consequently it would be quite safe to dispense with a large percentage of

"commercial" testing in favor of taking the elastic limit as a routine work. The time gained by dispensing with three-fourths of the work now done could thus be utilized to great advantage. Moreover, if the elastic limit were provided for us in specifications it would often be found that metals from different makers, which test alike as far as ultimate strength and elongation are concerned, would differ in their elastic limit. In other words, one metal would be found less fit to do useful work and therefore be inferior in quality, which inferiority, however, was not revealed with the prevailing method of testing. There can be no doubt of the importance and value of this additional advantage gained by the suggested change in method. Thus it will be seen that routine testing would become at once descriptive and comparative; descriptive as to quality for every day use and comparative as to quality of materials from different makers or different classes of materials.

What has been said will indicate the value and usefulness of systematic and scientific testing and the knowledge of the qualities and properties of metals. Indeed, the diffusion of such knowledge should receive very much attention in colleges, trade and industrial schools and shops. Alexander Holley, whose correctness of views and knowledge on metallurgical subjects no one questioned, used to say that our factor of safety was a factor of ignorance.

Professor Ledebur expresses the same sentiment when he says, in one of his recent works: "The question whether every one who makes use of iron (and steel) for his purposes possesses also the requisite knowledge of its qualities and properties must still be answered in the negative. This may seem paradox in the face of the fact that metals have been so extensively used for a thousand years. The reason, however, is that, first, changes in our industries have taken place during the last 30 years which necessitated the production of certain kinds of metals which were entirely unknown before. Second, because iron (and steel) is now used for many purposes where formerly only wood or stone was used; and, third, because only quite recently science has undertaken a thorough study of the mechanical properties of metals and the raw materials of which they are made."

Of the correctness of these statements there is ample evidence. The time-honored nursery tale of the recrystallization of iron under shocks and vibrations is still rehashed with evident satisfaction as a bit of traditional unscientific knowledge. Some even assert that steel also is possessed of this wonderful property of crystallizing while in a cold and solid state.

The penalty for the want of this indispensable, thorough knowledge of the chemical and physical properties of metals in this age of iron and steel, and the apparent indifference to acquire or diffuse such knowledge, is a heavy tax on our industries and the community at large, in the shape of wanton waste of our resources through excessive wear and tear of materials and their improper treatment. Since metals form the basis of our national industries and prosperity, we cannot afford with impunity to neglect the study of their properties, practically as well as scientifically.

The Construction of Gasholder Tanks.

The *London Journal* asserts that while a marked accession of interest has been imparted to the subject of gasholder design by recent suggested reforms of the established ideas of engineers relating to the conditions of gasholder stability, it is to be noticed that the construction of tanks has not been discussed with a view to any alteration of method for several years past. True, Mr. V. Wyatt not long ago offered a suggestion with regard to the building of gasholder tank walls in sections instead of in vertically-placed rings, as the common practice is, and claimed some economy for the method; but there is no sign of his plan being adopted anywhere. The exception in favor of Mr. Wyatt's as yet abortive suggestion only goes to prove the force of the remark that for many years—ever since, in fact, concrete was successfully taken into the service for tank building—nothing has been attempted by way of fundamentally improving, cheapening, or expediting the construction of gasholder tanks. The position of the gas engineer now contemplating the addition of another holder to his storage room therefore remains as it has been any time for the last 20 years. The first thing that occupies his thoughts is the tank—where it is to go, and of what it is to be made. In connection with all but the smallest works the tank is the care of one season and the holder of the next; and in some very large establishments the ground must be broken three and even four seasons before the prospective holder will be ready for work. Few engineers are so favorably circumstanced that the questions arising out of the situation and construction of a tank give no trouble. In the majority of instances the need for a tank brings the engineer face to face with an aggravating

array of contrary conditions. He may have settled in his mind for some years the site, dimensions and construction of his next tank, only to discover at the instant of taking the work definitely in hand some insuperable obstacle to the realization of his ideal. He may have reluctantly to confess that he wants an altogether bigger holder than he had vaguely promised himself; or experiences of a disturbing kind may have upset his half-formed plans. If he is a conscientious man, he desires to obtain the largest accommodation for his outlay; and perhaps he has little knowledge of any but local customs in building. Locality largely helps to settle the character of the work; but with all regard to this consideration, it remains true that the skill of the engineer is the most important factor in determining the cost.

Some men who undertake the designing of work of this order have very little notion of comparing cost with result; hence we see examples of tanks of equal capacities constructed for widely different sums in similar situations. One engineer thinks of nothing but making what he calls "a good job," and is utterly oblivious of the blame attached to the designer who wastes material. Another will have brickwork in a stone country, or *vice versa*; and will carry clay for miles, because he is afraid of cement rendering at half the cost of puddle. Another man is so nervous of water that he buys a costly wrought iron tank, merely because the last holder in the same place was so provided; and all the time cheap fuel and powerful pumps would enable him to get down a masonry tank at considerably less expense. There is nothing that tests the knowledge and judgment of a gas engineer like the making of a large tank in a given place. To do the work satisfactorily he needs to know how all the tanks in the neighborhood were built, and what they cost. He must be equally familiar with examples of the cheapest and dearest tanks in the country, in order to decide what of the former he may follow or even improve upon, and what of the latter can be avoided.

"Penny wise and pound foolish" ways must both be known and guarded against. The extravagance of material which is not conducive to strength, because lavished in the wrong place, is as abhorrent to the true engineer as weakness where substance of material is required at any cost. All possible materials and methods of construction must be weighed and compared, and the great question of "to pump, or not to pump," intelligently solved. It is hardly to be wondered at that so many tanks up and down the country fail, or when good, cost very much more than they ought, seeing the number of factors that go to the satisfactory selection of a design, to say nothing of the after troubles that may, and very often do, arise in connection with the nature of the subsoil or the character of the contractor. It seems a hard condition to lay down, that no engineer is justified in breaking ground for a tank unless he is humanly certain that his plan of construction is the best and most economical that could be arrived at in view of all the circumstances, and that in the event of unforeseen difficulties arising with the ground or the contractor he could take hold of the job and finish it for his employers. Yet short of this competence, there is no safety. In tank construction, above all enterprises, it is necessary to be prepared for the worst; so that unless a gas manager feels honestly capable of standing the test here laid down, he had far better confine his cares to the ordinary duties of his office and advise his directors or committee to put the extra work in the hands of a consultant.

The question may well be asked whether the conditions of tank construction, and more particularly for large works of the kind, have been altered of late by the introduction of mechanical improvements in excavating, building, etc. The sinking of foundations for great modern works, such as the Forth Bridge, the Eiffel Tower, and less notorious structures has brought out a number of devices unknown to the last generation of engineers, some of which are undoubtedly available for gasholder tank construction. One reads of and sees appliances for sinking shafts vertically and for cutting tunnels horizontally; and it would be gratifying if the excavation of ground for tanks could be effected by more expeditious and cheaper means than by the navvy and his timberings. Probably something could be done by way of pneumatic or mechanical sinking in the case of metallic tanks of large size; but no suggestion has been offered for reducing the labor of excavating the trench for a brickwork or concrete circular wall. Hoists and steam trollies for removing the soil, mechanical puddlers and concrete mixers, stone breakers, rock drills, and a variety of appliances of a like supplementary character will reduce the cost of digging out and walling a gasholder tank, as of a dock or railway cutting; but there is nothing specially to aid the tank constructor. The indispensable navvy is still the great agent in this class of work.

The capabilities of cement concrete as a material for the construction of gasholder tank walls are gaining acceptance every day, although not by any means so easily as might be supposed by those who have long

learnt its value. Puddling a tank to make it water-tight is so immemorial a device, however, that were it a less admirable one than it really is in suitable localities, it would long persist in spite of modern innovations. Far be it from any engineer to speak disrespectfully of puddle where it can be had as cheap as anything else; for a good puddled tank will remain sound until the end of time. Cases have actually been heard of where cement renderings, and even worse—cement sandwiched between inner and outer brick walls—have been used in tanks dug in solid clay that would have been as tight as a bottle almost without any puddling; but only the richest gas companies can afford to support the national manufactures in this lavish fashion. It is exceptional, however, for good clay to be met with throughout the whole depth of a large tank excavation; and where there is any doubt about the puddle, cement is fortunately a ready substitute. A concrete tank can be made out of almost any kind of "hard core;" and as it can be backed up against the solid earth of the cutting—must, indeed, be so built—there is a saving of excavation attendant upon its use.

The necessary thickness of a concrete tank wall is not to be hastily settled; but it is probable that the thickness may be reduced in a remarkable degree if plenty of iron is built into the wall. This latter is a most important—indeed it is the most important—element in the making of a staunch concrete tank wall. Stout bars of flat iron, curved to the radius for which they are required, and with their ends simply hooked together to form complete rings, laid on edge in the thickness of the wall, are the great safeguard for the structure. It may be said to be a point for consideration whether the weight of iron or of concrete shall preponderate in any particular example; but if this way of putting the question is regarded as open to the charge of exaggeration, it is better to incur this reproach than to run the risk of confusion of ideas between the weight of iron bars desirable to reinforce a slight concrete wall and the thin iron hoops commonly used to bond brickwork. Experiments made in the small way in forming concrete tanks for a variety of manufacturing purposes, have demonstrated the advantage of this mixed iron and concrete construction when the iron has been used more liberally and the concrete kept lighter than has ever been attempted for gasholder tanks. The fact that the expansion or contraction of iron for changes of temperature is practically the same as that of cement concrete removes the fear of fractures from this cause even in regard to structures of the combined material subjected to greater variations of temperature than are met with in gasholder tanks.

The modification of the guide-framing of gasholders, from heavy cast iron columns, concentrating their weight upon even heavier piers forming part of the tank wall, to the lighter standards required for the lattice framing lately in vogue, is a great relief to the tank builder. The idea was held that the piers helped the wall; but this service could only have been performed against the bursting pressure of the water, and not against the crushing force of the earth when the tank was empty, which was the greater danger. As against this problematical assistance, the piers (by unequal settlements) frequently pulled the tank walls out of the perpendicular, giving serious trouble to the gasholder maker. Now that guide columns are spoken of as likely to be dispensed with altogether, tanks should be easier as well as cheaper to make. In concluding this brief review of the conditions of modern gasholder tank construction, it should be remarked that several large examples of this class of work will be commenced during the present season in different parts of the country, full particulars of the most important of which will be given in the *Journal* in due time. From these it will appear whether any new procedure has been introduced into this branch of engineering since the latest designs already published were carried out.

Coal Fields of the State of Washington.

By W. J. WOOD, C. E.

The coal fields of the State of Washington, or, I might say more correctly, the coal measures of the Puget Sound basin, consist of alternating beds of sandstones and shales, interstratified with many beds of carbonaceous shales and coal, showing that the period or age is of tertiary formation.

It is found that they lie in a wide trough between the Cascade and Olympic ranges, and east of the Cascade mountains are found also extensive coal basins of older formations. The lignites of this country, however, are found in the central part of the trough lying west of the Cascade mountains and north of Green river, and stratigraphically in the upper series, while south of the above mentioned places and lower down in the measures will be found the true coals, or those resembling them. It is the prevailing theory that the tertiary rocks rest uncon-

ormably on the cretaceous—that is to say, that they were separated from each other by a lapse of time, during which the folding of the older coals and elevation of the mountains took place, and that probably after the development of the latter formations there was a general submergence, depositing the tertiary strata, which follows the cretaceous, and I have found in my examinations hints of the latter formations in various positions. But it is not improbable that in some places there may be a more or less complete strata of passage beds between the cretaceous and tertiary, as we find by comparison on the eastern slope of the Rocky mountains, where I observed hints of it three years ago in Colorado, Wyoming and Montana coal fields. I might add that it is quite possible that there may be two unconformable series of tertiary rocks. However, much of the disturbed strata observed by volcanic flues, recent drifts and a dense forest is not so materially affected or altered by geological changes as one might suppose, while undoubtedly many changes and faults have taken place which, as a matter of course, is a natural consequence in a volcanic and mountainous country. But, on the other hand, we find it adds greater advantage for mining purposes, as also in qualities, to find the measures more or less influenced by geological manœuvres, making them practically available for commercial value and rendering the same easy to mine, while, at the same time, we also find the measures in which the veins are described tilted about suitably in various degrees of angles, from 20° to 85°, as seen in the Wilkinson, Green river and Raging river coal fields, and east of the mountains, so as not to interfere with the working of the coal beds, providing proper mining methods are used. I have seen many mines where a suggestion would result in the mining of the coal in better shape for marketable use. The region over which this deposition occurred has since been the scene of mountain making and upheavals of stupendous volcanic eruptions and enormous erosions. Thus we see that the diversities and changes in coal measures which have occurred in the form of anticlinal axis, etc., are preferable in schemes of the working mines to the ordinary flat-vein coal fields, as natural ventilation can be had. The lifting of coal, also water, can all be done at a small cost, if the field to be operated is studied in advance.

Another feature which is to be added to the Washington coal fields, and one which is important, is the timber resources, which exist in vast quantities and in places very heavy, and are composed of fir, cedar, hemlock, spruce and maple. The same can be used for timbering in mines, where large sticks are required for props, etc. The timber resources in this State invariably accompany the coal measures, the latter being without exception overlaid with good standing timber, while in many other States the contrary is the rule, as in the Montana and Wyoming coal fields, where the timber is very light and sparse.

The definition of the boundaries and extent of the Washington coal fields, although a great many areas have been given, is correspondingly difficult, and in some locations and directions is an impossible task, although a description of the boundaries and approximate area will not be amiss, and will be near enough for exactness. The coal fields or the carboniferous area extend from beyond the British boundary south almost to the Columbia river, and from the Pacific ocean eastward to the foot hills of the Cascade ranges, and east of the Cascade ranges, beginning at the foot hills, 25 miles to a point or line running north and south parallel with the ranges, varying from 800 to 5,000 ft. in altitude above the sea level, but buried, on the one hand, beneath recent gravel beds and overflowed, on the other, by eruptive masses; within the boundaries of the above described lines of 8,000,000 to 10,000,000 acres of mineral lands there are probably from 600 to 700 square miles of coal lands, of which a slight portion only is yet developed. The coal ranges in quality from a semi-anthracite up through the other qualities of coals, such as bituminous blacksmithing, lignites, gas and coking coal, and is in inexhaustible quantities. The best sections are those of the Wilkinson and Green river fields, where large amounts are shipped yearly, as also from the Franklin mines, Roslyn and Cle-Elum coal fields and a great number of other successful operating mines which could be mentioned, some of them turning out from 50,000 to 200,000 tons annually. There are over 20 mines in operation, with the prospect of the opening of three new coal fields this year.

While there are many varieties and qualities of coal, there are also many different analyses, but an analysis of one is approximately that of all. In this case it is a bituminous coal having upward of 59 per cent. of fixed carbon and, in some cases, as high as 66 per cent.; volatile matter, 28 per cent.; ash, less than 5 per cent.; sulphur, none. With the lignite we have excellent grades and qualities, which surpass the lignite seen in many other sections of the country. Where I have observed, the quality and grade of the lignites in these sections is probably due to action of a volcanic nature influencing the character of

the coal, thus producing a hard, brilliant coal of moderate heating power. It finds a ready market in all cases where the demand for cleanliness and cheerfulness overrules the economy of the greater heating power of the more highly bituminous coal.

On the semi-anthracite of the Natchez and Cowlitz Pass coal fields extensive measures and croppings of large veins of coal have been discovered, the strike and pitch of which extend for several miles, forming anti and monoclinax axes in basins of unknown area, and showing good analysis of the strongest indication for the best uses and purposes of coke making. This section of the country lies dormant in one of the most secluded and remote parts of the mountains. A railroad has been talked of to open up these fields of coal, as it is deemed desirable to tap these fields, owing to the coking and bituminous qualities thus recommended. The coal in this region is probably the result of volcanic rocks running in contact with the coal measures, as faults and as intrusive dikes. They have modified the character of the coal from its original state by pressure and heat, and the influence of a superficial flow would in both these respects be less than that of molten rock before extrusion. Thus the beds of coal have been altered to semi-anthracite of a brilliant luster and an anthracite fracture, and in some places the change is sufficient to produce a bituminous or coking coal.

Here we have reviewed the several kinds of coal, qualities and probable area. In conclusion, I would add that, while at present the Washington coal is generally used for steam and domestic purposes, the general quality of other coals so far discovered in this State is found to be adapted more particularly for making gas and cooking purposes. In either case the coal is very desirable and valuable.

Preservation of Wood by Chemical Means.

Probably the best preserved wood in the world which has been used by man is that found in ancient Egyptian temples at least 4,000 years old. The wood appears to be tamarisk or chittin-wood, and is found as dowel-pins connecting stone work. In removing the old London Bridge, in 1829, piles driven 800 years before were found in good condition. Most of the wooden parts of the roof of Westminster Hall were in good preservation after an equally long period. But if wood may be thus long preserved by accidents of nature, surely chemistry, whose resources are nearly as wide as those of nature herself, can reproduce the accidental conditions, if they are thoroughly understood. It would be difficult to mention any cheap chemical agent which has not, at some time, been proposed as a wood preservative. No less than 57 patents have been taken out in England on various methods of timber preservation. Of these, however, it is well to remark that many were patents on minor detail of the same processes, and also that most of the methods were impracticable.

A solution of corrosive sublimate was used in France early in the 18th century for impregnating wood for protection against insects and decay. It was tried by the Dutch Government in 1730 for protecting its ships against the teredo worm. Owing to the solubility of the sublimate in water, especially in sea water, the process was a failure for wet situations. Mr. J. H. Kyan obtained a patent in England in 1832 for a method employing a solution of one part corrosive sublimate in 50 parts water, and for a long time kyanising was quite popular. It has met with considerable success for timber to be placed in comparatively dry situations. The disadvantages of corrosive sublimate are its inefficiency on account of solubility in water, and its poisonous effect on workmen handling lumber impregnated with it. It is also very expensive, and therefore not practical in many instances.

Mr. J. J. Lloyd Margary in 1837 introduced and patented in England the substitution of copper sulphate (blue stone) for corrosive sublimate. It had the advantage of cheapness, and was regarded as one of the most successful of all metallic salts as an antiseptic for timber. This method is still used in France. The objection of solubility applies here also. Mr. Chas. Payne sought to avoid this by first impregnating the timber with iron sulphate, and then with some salt like calcium chloride or sodium carbonate, which reacting with the iron sulphate would give an insoluble precipitate within the cells of the wood. The process is of historical interest only, as it was an utter failure, probably by reaction taking place before the second solution had penetrated the wood, thus preventing its own entrance any deeper, and the resulting timber being protected only quite near its surface. Dr. Boucherie, in 1837, in France, proposed zinc chloride, which is a powerful antiseptic, but extremely soluble in water. The process is known as burnettising, since it was introduced in England by Sir Wm. Burnett. For dry situations, owing to its cheapness and efficiency, it is more largely used than any of the foregoing methods—principally in Holland, Germany and this country.

The way the metallic salts effect the desired end is by forming a chemical compound with the fermentable constituents of the wood—that is, by coagulating the albumen, etc., or, according to the more recent theory of putrefaction, their preservative powers depend on their being poisonous to the bacteria, thus acting as germicides. As early as 1756 attempts were made both in England and America to impregnate woods with vegetable tars or portions of such tars. Coal tar was probably first proposed by Franz Moll, who took out a patent in 1836. He recommended the use of oils both lighter and heavier than water. This was never carried out, as it was obviously wasteful to inject the lighter oils which would soon evaporate.

Various modifications have been continuously made from time to time—mainly in the composition of the creosote used and in the machinery for impregnation. Of course, every creosoting company has its own particularities as regards details, but in general the timber is placed in iron cylinders, sufficient melted creosote added to cover the timber, a partial vacuum produced by an air pump, the whole kept at a temperature of about 110 to 120° F. for several hours, when the air pump is stopped and the pressure pump put on till a pressure of 6 to 16 atmospheres is made in the cylinders, the heat still continuing, and the process being completed in from 12 to 48 hours, depending on the size of the timber. The advantage of the vacuum at beginning of process lies in that water and all liquids boil at a lower temperature under decreased pressure, and consequently the little moisture in the wood is evaporated at a temperature too low to injure the wood. The timber being thus more thoroughly dried, the tar enters more readily and penetrates deeper.

Another quite common plan is merely boiling the wood in coal tar tanks. This is not so good, since nothing like the 10 or 15 pounds of tar per cubic foot forced into the wood under pressure can be obtained by the open tank process. Still another method—and a poor one, too—is painting the wood with boiling tar. To ensure perfect preservation the proper kind of tar should be disseminated all through the wood. As to what is the proper kind of tar, authorities differ, some favoring the lighter tar oils, since these contain a higher proportion of tar acids—carbolic, cresylic, etc.—which they claim prevent decay by killing the germs of putrescence, or by coagulating the albumen, etc., of the wood. Others say that it cannot be these acids which effect the preservation of the wood, since they are volatile and soluble in water, and therefore do not remain in the wood, but that the wood is preserved by some constituent of the heavier oils. This last view seems to be the correct one, since actual experiment has proven the heavy oils equally as good, if not better, than the lighter oils containing 10 or 12 per cent. of the tar acids. The best authorities now believe the active principle in creosote wood preservation to be acridine—found in the heavier oils only. Now, acridine is a deadly germicide, and it coagulates the albumen. The oily body of the tar prevents the entrance of germs and of moisture into the interior of the wood, and this must play no unimportant part in the success of the creosote method.

ITEMS OF INTEREST FROM VARIOUS LOCALITIES.

GAS was turned on to the mains of the Hamilton, Ohio, municipal gas works on the evening of the third inst.

WE can also say that Mr. Jas. R. Smedberg, under whose supervision the Hamilton works remained from their inception, has been appointed Superintendent of the plant.

ARTICLES have been filed with the Secretary of State of New Jersey, incorporating the Knapp-Campbell Gas Company. It is capitalized in \$2,000,000. The officers chosen to serve in the first year are: Directors, A. Blumenthal, G. Blumenthal and F. B. Spooner, of this city, H. D. Campbell, of Brooklyn, N. Y., J. L. Berg, of East Orange, N. J., and Reed Campbell and D. H. Knapp, of Norwich, N. Y. President, Albert Blumenthal; Vice-President, David H. Knapp; Treasurer, Gustave Blumenthal; Secretary, James L. Berg. We presume this Company is formed for the purpose of exploiting the Knapp gas making apparatus, a description of which will be found in our issue for December 9, 1889, p. 823.

THE proprietors of the Vineland (N. J.) Gas Light Company, which corporation can now be said to be freed from the financial entanglements that so sorely emmeshed it a year or two ago, have completed a most systematic and thorough overhauling of the main system, carried out under the intelligent direction of Mr. A. W. Tarbell, of Waltham, Mass. The betterments also included the placing of a street governor,

and general repairs to carbonizing apparatus. To show that Mr. Tarbell's plan of main overhauling answered his expectations and the desires of the Company may best be proved by the following. The final meter tests by sections of mains showed a total leakage (on the 5 miles comprising the system) of 34 feet per hour. This means, on comparing the result with that proved before the work of repair was undertaken, to the Vineland Company an annual saving of 700,800 cubic feet of gas, or a reduction in the leakage account of from 25.33 per cent. in 1889, to about 7 per cent. in 1890, without mentioning anything in the saving sure to result from checking the day pressure almost 50 per cent. Money may be made in the carbonizing house, but it is surely lost in the street department, if the service of the latter is imperfect. Look to your street mains.

MR. E. T. ROWELL, of the Massachusetts Gas Commission, has been elected President of the Railroad National Bank, of Lowell, succeeding Mr. Jacob Rogers, who will spend the summer in Europe.

THE East River Gas Company has filed a certificate of incorporation. It is capitalized in \$1,000,000, and will manufacture and sell gas in Long Island City and Newtown, Queens county, L. I. The Trustees returned for the first year are: Philip Burkhard, L. I. City, Isaac L. Egbert, Clinton Tabor and Franklin Everhard, of New York, and A. D. Ballard, of Yonkers, N. Y. Quite likely this Company is a corporation that either has taken or will take over the franchises and rights of the present Company doing business in the localities named.

CORRESPONDENCE from Indianapolis, Ind., dated May 2d, is to the following effect: "The power of electricity as a death-dealing agent was demonstrated at the works of the Brush Electric Light and Power Company, here, at midnight last night, when James Clark, an employee, was instantly killed by a shock. Clark had charge of two dynamos, and also assisted in operating the switchboard. The engine operating one of the city circuits had been running 'hot' all evening, and the night engineer gave Clark orders to change the city circuit to one of the commercial engines. A circuit is changed by shifting the wires on the switchboard. Attached to the end of each wire is a wooden handle through which the insulated wire passes. This handle fits into a brass neck and ring with which the wire is hooked on to the switchboard. In shifting the current Clark unhooked the city wire with his left hand and the commercial with his right. As he did so one of his fingers accidentally came in contact with the metal at the end of the wooden handle on the commercial wire. The current, 4,000 volts, threw him backward a distance of 20 feet. Death was instantaneous."

QUITE a rumpus was raised by certain citizens of Memphis, Tenn., in respect to a petition that had been submitted to Council by the Equitable Gas Light Company for the right to cross Horn Lake road in front of its works by means of a railroad track of standard gauge. The Company, however, was enabled to show beyond doubt that less inconvenience and danger would be occasioned to residents of the vicinity under the proposed practice (in the matter of transport of materials) than was the case under the existing methods, whereupon Council acquiesced in the petition.

THE Columbus (O.) Gas Light and Fuel Company has, in response to an invitation from the authorities, submitted a bid for the public lighting, and suggests therein the possibility of the city using gas to better advantage than could be the case with electricity. The agents by which this could be accomplished are named as the Gordon lamp and an "open burner" of the ordinary type, to consume 8 cubic feet of gas per hour. The letter to the Board of Public Works, which is signed by General Manager Irvin Butterworth, for the Gas Company, then goes on to say: "If granted a 10-year contract, this Company would agree to furnish as many of the above lamps, of either or both kinds, as your Board should see fit to order (the number, once ordered, not to be decreased during that time), and maintain, clean, light, extinguish and furnish gas to them, all at the rate of \$45.75 per year for Gordon lamps, and \$21.40 for the 8-foot open burners, if lighted during all dark hours—that is to say, 2,500 hours per year; or at the rate of \$57.80 for the Gordon lamps and \$26.20 for the open burners, if lighted all night and every night during the year. Herewith submitted is a map of the city, upon which are marked the locations of the various kinds of lamps—electric, Gordon, open burner and gasoline—for the purpose of illustrating the saving which may be effected in the street lighting of the city. It will be observed that the electric lights remain upon all the street car lines, and that the gasoline lamps are necessarily marked upon the outlying portions of the city, and in other places not at present supplied by the

Company's mains. It is likely that if we should be given a 10-years' contract we would be warranted in making liberal extensions to our present system of mains, if your Board should desire that we light a larger area than is now covered by them. Upon the plan illustrated upon the map there would be: 152 electric lights at \$80 per year, \$12,160; 145 Gordon lamps, at \$45.75 per year, \$6,633.75; 544 open burners, at \$21.40 per year, \$11,641.60; and 1,100 oil lamps, at \$15.75 per year, \$17,325, making the total cost for lighting per year \$47,760.35; present cost, \$76,000; saving per year \$28,239.65. Of course, your Board could modify the above number or arrangement of the lights in any manner that you might find would conduce to a better result, and the total cost would be affected in accordance with the foregoing prices, and could easily be calculated. The price herein named for gasoline lamps we are authorized to quote by Jones & Underhill, of this city. We believe that the above, or some similar arrangement of the lamps, would light the city better than most cities in the country are lighted. The lighting would be more thoroughly distributed, and there would be no dark alleys and corners. We believe it would give the people fully as good satisfaction as the present lighting. You will bear in mind that our proposal contemplates the assumption on our part of the first cost of the lamps, the expense of their maintenance and care, and the cost of lighting and extinguishing, the city being at no expense, except for the lamp posts, of which it already possesses a large number not at present in use. Furthermore, the 'all dark hours' lighting would be a total of 2,500 hours per year, whereas, ordinarily, the lighting under the new light schedule is calculated at 2,100 to 2,200 hours per year. In the case of the open burner gas lamps, as heretofore mentioned, they will be made to consume 8 cubic feet of gas per hour. Such lamps in other cities never consume more than 4 to 6 feet, as you will see by the chart which accompanies this map. In fact, an examination of this chart will show you that our proposed charge for the open burner lights is far the most liberal of any charge made in the cities therein reported, and the gas consumed by the Gordon lamps is not only to be charged for at the same rate per 1,000 feet, but the gas consumed by them gives a great deal more light per foot consumed than the open burners. A comparison of the cost of street lighting in Columbus with what is paid in other cities, shows that our streets are being extravagantly lighted. The cost in Columbus is equivalent to 76 cents per capita per annum, whereas, for example, it is 60.5 cents in Grand Rapids, 59 cents in Mansfield, 48 cents in Detroit, 40 cents in Cincinnati, 35 cents in Indianapolis, and 22 cents in Allegheny. We would guarantee to save the city 25 per cent. of what the streets could be lighted for by electricity." The proposal was referred to a committee.

A MEETING of the shareholders of the Birmingham (Ala.) Gas, Electric Light and Power Company is to be held in that city on the 2d prox., to determine whether or not a mortgage of \$300,000 shall be put on the property, and to consider the advisability of "selling its electric light plant and privileges, easement, and franchises appurtenant thereto."

MESSRS. WHITE AND CALL, acting for the proprietors of the Marquette (Mich.) Gas Light Company, have published the following circular: "The price of gas has been reduced from \$2 to \$1.50 per 1,000 cubic feet, and gas bills will hereafter be rendered at the latter rate. This price, we believe, is lower than in any city in the West or Northwest, where the population and the rate of gas consumption are not greater than in Marquette. We are now making an excellent quality of gas, and with proposed additions and improvements to be presently made to our plant we expect to offer gas to our customers for cooking and heating purposes, and believe many of the housekeepers of the city will be glad to avail themselves of its use, and will be pleased with its cleanliness, convenience, and economy." Gas at \$1.50 per 1,000 would be reasonable almost anywhere; hence it is more than reasonable at Marquette.

AT the annual meeting of the Cumberland (Md.) Gas Light Company the following result was reached: Directors, Messrs. E. T. Shriver, John McIlhenny, Robt. Shriver, Harrison Swartzwelder, and James Gardner; President, E. T. Shriver; Secretary and Treasurer, Webster Bruce; Superintendent, J. F. Seamon.

THE title of the Grand Rapids (Mich.) Gas Light Company has been changed to that of the Grand Rapids Gas Company.

THE ordinance by which the price of gas was fixed at \$1.25 per 1,000 to the city and \$1.35 to the public of Toledo (with 10 cents per 1,000 off for prompt payment) expires on Oct. 8, 1890, and the Mayor suggests that the "Common Council and the Gas Committee should be prepared, before

the 1st of October, with a new ordinance establishing the price of illuminating gas for a period of 3 or 5 years." He urges this early attention because in his opinion the proper determination of that question will require considerable study and investigation. And a lot of gammon, too, Mr. Mayor, on the part of the city.

A SPECIAL from Harrisburg, Pa., dated April 30th, says: "Judge Simonton to-day handed down two opinions in the Commonwealth's cases against the Philadelphia Electric Lighting Company and the Brush Electric Light Company, of Philadelphia. Both of these Companies claim to be manufacturing companies, and, as such, exempt from taxation under the recent act removing the tax from manufacturing companies. The opinions discuss at great length the means by which electricity and electric light are produced, and quote extensively from the testimony of Professor Henry Morton, President of the Stevens Institute of Technology, whose testimony as an electrical expert was taken in these cases. But Judge Simonton adheres to his opinion promulgated in a somewhat similar case about one year ago, that producing electric light is not a species of manufacture. He held that neither electricity nor electric light was a material substance, and that there could be no manufacture unless some material substance was produced. It is expected that these cases will all be argued in the Supreme Court, on appeal, at its meeting here next month."

THE authorities of Revere, Mass., have granted a contract to the North Shore Electric Light Company under which the latter will, for a period of 3 years, maintain 175 incandescent lamps (26-candle power) at a rate not to exceed \$16 per annum each, on an all-night table; also, 15 arcs, of 1,200-candle power each, to burn from sundown to 12:30 A.M., at the rate of \$72 per annum each.

THE public lighting by gas of New York city, for a year from 1st inst., has thus been allotted by the Gas Commission:

Company.	No. Lamps.	Price per Lamp.
Consolidated.....	17,150	\$17.50
Mutual.....	280	17.50
Equitable.....	3,600	12.00
Central.....	2,675	27.00
Northern.....	2,200	28.00
Yonkers.....	557	28.00

WE presume that the enthusiastic supporters of the movement for municipal control of electric lighting stations and gas works will find little food for consolation—it might set them thinking, however—in the fact that the Bay City (Mich.) Common Council has about decided to sell out the municipal electric lighting station now owned and operated by the city.

THE West Arlington Improvement Company will probably construct a gas works at West Arlington, Md. D. MacIneston, of New York, is President of the Improvement Company.

THE new Methodist Church building at Downingtown, Pa., is to be lighted by gas. There was quite a contest between the local Gas and Electric Light Companies over the contract.

THROUGH the courtesy of Mr. T. R. Parker, of San Jose, Cal., we are informed of the death in that city, on April 27th, of Mr. John Fullagar, formerly Superintendent of the Cincinnati (Ohio) Gas Light and Coke Company. The cause of death was heart failure. In his brief note to us on the sad affair Mr. Parker wrote: "Thus ends the life of an energetic man, a kind father, a firm friend and a congenial gentleman." We hope in due time to give to our readers some account of Mr. Fullagar's life.

IN a suit brought in the United States Circuit Court, Boston, Mass., before Judge Colt, the Electric Gas Lighting Company sued Charles E. Fuller, the action being a bill in equity brought for infringement of letters patent, No. 225,071, granted to Henry F. Packard, and No. 232,304, granted to C. N. Sanford for improvements in electric gas lighting apparatus. The patents relate to that form of electric gas lighting where the burner is operated by hand, and which does away with the use of matches. The Sanford device is substantially like the Packard. The apparatus covering both of the patents is called the Packard-Sanford burner, and it appears to have been the first burner of this class which obtained any large degree of commercial success. The defence mainly relied upon is that there was no invention in what Packard did, in view of the state of the art at the time. Judge Colt says: "The Court finds in none of the prior devices the combinations referred to in the third and fourth claims of the Packard patent, and

recognizing the prior state of the art. I think it called for the exercise of the inventive faculty as distinguished from mere mechanical skill to produce the Packard device. Upon the question of infringement I have no doubt."

WE understand that the Selectmen of Marlboro, Mass., have granted the promoters of the Citizens Gas Light Company a franchise.

GOVERNOR BRACKETT having signed the bill repealing what is known as the carbonic oxide law of Massachusetts, water gas can be made in that State without any restriction whatsoever.

ADVICES from Boston are to the effect that on the morning of the 2d inst. Attorney General Waterman forwarded to the House of Representatives, in reply to its order, an opinion that cities and towns have no right to make and sell gas for private use, nor to make it for their own use. He examined the status of cities and towns separately. As to towns he says: "I can find no law or statute by which towns have been authorized to enter into business of a commercial or private nature, such as requires an investment of capital and the employment or particular application of skilled labor or scientific knowledge therein. And I am of the opinion, for the reasons above stated, that under existing statutes towns have no authority to construct and maintain within their own limits and for their own use systems of lighting by gas or electricity; nor can they in connection with such systems sell gas or electricity for private use in such towns." Regarding cities he also gives his reasons and concludes that "cities as well as towns have no authority to construct and maintain either gas or electric light works."

THE Duluth (Minn.) Gas and Water Company has ordered 500 tons of gas and water mains from the West Superior pipe works.

THE May term Grand Jury of Chicago, has found an indictment against Charles V. Henkel, on a charge of embezzling \$2,000 from the Globe Light and Fuel Company of 195 Michigan street, that city.

THE proprietors of the Westfield (Mass.) Gas Light Company have voted to reduce the gross price of gas, to consumers of 20,000 cubic feet per month, to \$2.37 per 1,000, and to consumers of less than that quantity to \$2.50, prompt payment to entitle the consumer to a rebate of 10 cents per 1,000.

WE were recently in receipt of the following circular, copies of which have been extensively distributed throughout the central West. We cheerfully give to Messrs. Hayes & Co. this free advertisement, in the full knowledge that it will curtail their receipts. The circular reads: "Do you burn gas? Do you desire to save 25 to 40 per cent. on your monthly bill?—If so, send 50 cents either in stamps or by postal note to the undersigned, and by return mail receive a simple device which has proved this result can be achieved in any business place, hotel or residence in this country. The device and manner of applying it is very simple. It is neat, safe and clean, saving your ceilings from being disfigured by smoke. Once attached, they last the lifetime of the fixtures. The information imparted to you with this device will enable you to change all the burners you may control at a mere nominal cost and the time it will take to adjust them. The question has been asked, Have the public any rights which the gas companies are bound to respect? We answer, Yes. With our device you will only receive what you pay for, and pay for what you receive, and the company will have no way to doctor the meter to produce other results. The thousands already in use justify the above statement. If you personally have no need of this information, please hand this to some friend who may desire to avail himself of this privilege, and greatly oblige C. H. Hayes & Co., 1615 Hough avenue, Cleveland, O. In writing us, give full post office address, which will lessen the chances of delay and miscarriage." Naturally, wishing to keep up with the best practice of the day in the matter of how to burn gas properly or to the best advantage, we at once applied by letter to Mr. G. A. Hyde, of the Cleveland Gas Light and Coke Company, for information respecting the Hayes device, and received from that gentleman the following response: "Replying to yours of the 3d inst., we had received a similar circular and inquiry from another party recently, and sent a person to purchase the device advertised. It proved to be nothing more nor less than the stuffing of a burner with cotton to accomplish the desired result." Perhaps Hayes & Co. will not be grateful for this advertisement.

MR. E. A. VAN HORNE has handed in his resignation to the proprietors of the Utica Gas Company, in order that he may accept the position of Superintendent of the Syracuse (N. Y.) street railway system.

MR. WM. LAWLOR, Superintendent of the Lincoln (Neb.) gas works, was badly burned about the face and shoulders while making an inspection of some repairs that had been made to a boiler in the generating room of the works. The accident occurred on the morning of April 28th.

AN attachment for \$136,063.53 has been sued out in the Circuit Court of Chicago by Robert Fulton Cutting against Nicholas C. Miller, who is plaintiff in the suit to set aside his sale of the Lake Gas Company to the syndicate headed by C. R. Cummings. Mr. Fulton's claim is based on a judgment recovered by him against Miller in the Supreme Court, this city, on March 11.

THE annual meeting of the Wilmington (N. C.) Gas Light Company was held on the morning of April 29th, Mr. D. G. Worth acting as Chairman, Mr. J. C. Chase acting as Secretary. The election for Directors resulted in the following choice: Capt. John F. Devine, Dr. A. J. De Rossett, and Messrs. E. S. Martin, Donald MacRae, Geo. W. Kidder, G. H. Smith and Geo. R. French. The Directors subsequently effected the following permanent organization: President, E. S. Martin; Secretary and Treasurer, R. J. Jones; Superintendent, J. W. Reilly. The Company enjoys a most prosperous business.

THE formal transfer of a majority of the shares in the Troy (N. Y.) Electric Light Company to the Troy Gas Company was made on the afternoon of April 29. It is possible that Joseph A. Powers will be retained as Manager.

THE Waukegan (Ills.) Light, Heat and Power Company has been incorporated, with a capital of \$60,000, by Messrs. William Stubbs, De Witt Stearns and W. L. Duston.

ACCORDING to the city's books, Rochester, N. Y., maintains 2,719 public lights of all classes. Of these 846 are ordinary gas lamps, paid for at the rate of \$18.25 each per annum; 1,083 are of the arc electric type, and which cost 28½ cents each per night; and 790 are of the incandescent electric type (20-candle power), charged for at 4½ cents each per night.

THE proprietors of the Chattanooga (Tenn.) Gas Light Company, in order to encourage the use of gas for cooking, heating and power, have agreed to allow, from the first inst., a discount of 40 cents per 1,000 on bills for gas used in stoves and gas engines. This is equivalent to a net rate of \$1.30 per 1,000.

THE cases of the Laclede and Carondelet Gas Light Companies against the city of St. Louis to enjoin the latter from enforcing the ordinance reducing the price of gas to 90 cents per 1,000 cubic feet, have been ordered continued in Judge Valliant's court until the 20th inst. The court granted a restraining order against the city. In the meantime City Counsellor Bell has filed three petitions in the Supreme Court asking for a writ of mandamus against the Gas Companies to show cause why they continue to disobey the ordinance.

Correspondence

[The JOURNAL is not responsible for the opinions expressed by correspondents.]

Electric Lighting at St. Louis.

ST. LOUIS, MO., May 4, 1890.

To the Editor AMERICAN GAS LIGHT JOURNAL:

On May first St. Louis was lighted for the first time with electric lights; arc lights being used on the streets and incandescent lamps in the alleys. It is safe to assert that never before was St. Louis so brilliantly lighted as it has been since the advent of electricity. When the city was lighted with gas a moonlight schedule was followed. That is to say, when the moon was shining brightly the gas was not turned on. During the past few evenings we have had a clear sky with a bright moon, with all the electric lights going and all the gas lamps lighted to help them. The moon can't continue much longer to aid the electric light, and must retire from business for a time, of course; but the gas lamps are kept burning by order of the Mayor until the electric lights shall have burned satisfactorily for at least 5 nights. To date they have not done so. The city was to be fully lighted by electricity, January 1st. Then the contractors obtained an extension of time until May first, when they claimed to be ready, after a number of trials with the light, the result of which is thus briefly told. There seems to be, after all, a good deal of uncertainty and not a little humbug connected with the electric light. If gas lighting were as dangerous to human life and property as electric lighting has proved to be the daily newspapers would protest all over the land; but, strange to say, the newspapers have nothing to say now. The electric light is probably a newspaper pet, the same as the gas company and the plumber are its old-time chestnuts for bad jokes and abuse, at times when other matter is "short."

MOUND CITY.



A. M. CALLENDER & CO.,
PROPRIETORS.

EDITOR—Jos. R. Thomas, C.E.
ASST. EDITOR—T. J. Cunningham.
MANAGER—C. E. Sanderson.

PUBLISHED ON EACH MONDAY OF THE YEAR AT
No. 42 Pine Street, New York.

This is a recognized official organ of
LIGHT, HEAT, STEAM, WATER SUPPLY,
VENTILATION, SANITARY IMPROVEMENT,
AND GENERAL SCIENCE

TERMS:

SUBSCRIPTION—Three Dollars per annum, in advance. Single copies, 10 cents.

AGENTS.

NEW YORK.—AMERICAN NEWS CO., 39 and 41 Chambers Street.
PHILADELPHIA.—PRATT & CO., Corner Ninth and Arch Streets.
Germany.—B. WESTERMANN & CO., of New York.

MONDAY, MAY 12, 1890.

Gas Stocks.

Quotations by Geo. W. Close, Broker and
Dealer in Gas Stocks,
16 WALL ST., NEW YORK CITY.

MAY 12.

All communications will receive particular attention.
The following quotations are based on the par value of \$100 per share.

	Capital.	Par.	Bid	Asked
Consolidated.....	\$35,430,000	100	100 $\frac{1}{8}$	—
Central.....	500,000	50	85	95
“ Scrip.....	220,000	—	95	100
Equitable.....	4,000,000	100	118	122
“ Bonds.....	1,000,000	—	113	115
Harlem, Bonds.....	170,000	—	—	—
Metropolitan, Bonds....	658,000	—	115	120
Mutual.....	3,500,000	100	110	—
“ Bonds.....	1,500,000	—	100	102
Municipal, Bonds.....	750,000	—	—	—
Northern.....	—	50	—	—
“ Bonds.....	150,000	—	—	100
Standard Gas Co--				
Common Stock.....	5,000,000	100	—	45
Preferred.....	5,000,000	100	84	87
Yonkers.....	—	50	112	—
Richmond Co., S. I.	346,000	50	—	—
“ Bonds.....	20,000	—	—	—
Gas Co's of Brooklyn.				
Brooklyn.....	2,000,000	25	114	117
Citizens.....	1,200,000	20	70	72
“ S. F. Bonds... ..	320,000	1000	100	103
Fulton Municipal.....	3,000,000	100	127	130
“ Bonds....	300,000	—	100	105
Peoples.....	1,000,000	10	86	88
“ Bonds (5's).....	368,000	—	100	—
“ “ (6's).....	94,000	—	100	—
Metropolitan.....	1,000,000	100	102	—
Nassau.....	1,000,000	25	120	—
“ Cfts.....	700,000	1000	100	102
Williamsburgh.....	1,000,000	50	125	—
“ Bonds... ..	1,000,000	—	110	112

Out of Town Gas Companies.

Boston United Gas Co.—				
1st Series S.F. Trust	7,000,000	1000	93	93 $\frac{1}{2}$
2d “ “ “	3,000,000	1000	71	72
Bay State Gas Co.—				
Stock.....	5,000,000	50	79	80
Income Bonds.....	2,000,000	1000	—	—
Buffalo Mutual, N. Y....	750,000	100	90	95
“ Bonds...	200,000	1000	95	100
Citizens, Newark.....	1,000,000	50	155	160
“ “ Bonds.	45,000	—	—	—
Chicago Gas Trust.....	25,000,000	100	58 $\frac{3}{4}$	—
Chicago Gas Light. & Coke Co.—				
G't'd Gold Bonds	7,650,000	1000	97 $\frac{1}{2}$	98 $\frac{1}{4}$
Equitable Gas & Fuel Co., Chicago, Bonds	2,000,000	1000	94 $\frac{7}{8}$	95 $\frac{1}{2}$
People's Gas and Coke Co., Chicago—				
1st Mortgage.....	2,100,000	1000	—	100
2d “	2,500,000	1000	96	100
Consumers Gas Light Co., Jersey City.....	2,000,000	100	20	—
Bonds.....	600,000	1000	80	—
Cincinnati G. & C. Co..	6,000,000	100	201	203
Consumers Toronto....	1,000,000	50	190	200
Central, S. F., Cal.....	—	—	80	90
Capital, Sacramento, Cal	—	—	58	—
Consolidated, Balt.....	11,000,000	100	49 $\frac{1}{4}$	49 $\frac{1}{2}$
“ Bonds.....	6,400,000	—	107	107 $\frac{1}{2}$
Citizens Gas Lt. Co., Rochester, N. Y.....	500,000	—	75	90
Bonds.....	250,000	—	—	—
Hartford, Conn.....	750,000	25	102	108
Jersey City.....	750,000	20	170	175
Laclede Gas Light Co., St. Louis, Mo.—				
Common Stock....	7,500,000	100	24 $\frac{3}{4}$	25
Preferred “	2,500,000	100	—	—
Bonds.....	9,034,400	1000	84	85
Louisville, Ky.....	2,570,000	50	125	130
Little Falls, N. Y.....	50,000	100	—	100
“ Bonds	25,000	—	100	103
Montreal, Canada.....	2,000,000	100	200	208
Memphis (Tenn.) Gas... ..	750,000	100	40	—
“ Bonds.	240,000	100	103	—
New Haven, Conn.....	—	25	200	—
Oakland, Cal.....	—	—	35	35 $\frac{1}{2}$
Peoples, Jersey City... ..	—	—	60	61
“ “ Bonds..	—	—	—	—
Paterson, N. J.....	—	25	99	102
Rochester, N. Y.....	—	50	99	100
Syracuse, N. Y.....	500,000	25	—	—
San Francisco Gas Co.				
San Francisco, Cal....	10,000,000	100	55 $\frac{1}{2}$	55 $\frac{3}{4}$
Washington, D. C.....	2,000,000	20	200	208
Wilmington, Del.,	—	50	88	90

Advertisers Index.

GAS ENGINEERS.

	Page
Jos. R. Thomas, New York City	681
Wm. Henry White, New York City	687
Wm. Mooney, New York City.....	681
William Gardner, Pittsburgh, Pa.....	681
Fred. Bredel, N. Y. City.....	683

GAS WORKS APPARATUS AND CONSTRUCTION.

James R. Floyd & Sons, New York City	687
Continental Iron Works, Greenpoint, L. I	687
Delly & Fowler, Phila., Pa	687
Kerr Murray Mfg. Co., Fort Wayne, Ind	681
Stacey Mfg. Co., Cincinnati, Ohio	687
Bartlett, Hayward & Co., Baltimore, Md.....	685
Morris, Tasker & Co., Limited, Phila., Pa.....	685
Davis & Farnum Mfg Co., Waltham, Mass.....	684
R. D. Wood & Co., Phila., Pa.....	686
Bouton Foundry Co., Chicago, Ills	687
Smith & Sayre Manufacturing Co., New York City.....	686
Fred. Bredel, N. Y. City.....	683
United Gas Improvement Co., Phila., Pa.....	677
National Gas Light and Fuel Co., Chicago, Ills.....	674
Stimpkin & Hillyer, Richmond, Va.....	671

GAS AND WATER PIPES.

Gloucester Iron Works, Phila., Pa.....	681
Mellert Foundry and Machine Co., Reading, Pa. (John Fox, Selling Agent, N. Y.).....	681
Ohio Pipe Co., Columbus, Ohio.....	681
M. J. Drummond, New York City.....	681
R. D. Wood & Co., Phila., Pa.....	686
Warren Foundry & Machine Co., New York City.....	681
Donaldson Iron Co., Emaus, Pa.....	681
Dennis Long & Company, Louisville, Ky.....	681

PROCESSES.

National Gas Light and Fuel Co., Chicago, Ills.....	674
Bartlett, Hayward & Co., Baltimore, Md.....	685
Wm. Henry White, N. Y. City.....	687
United Gas Improvement Co., Phila., Pa.....	677
The Fuel Gas and Light Improvement Co., N. Y. City.....	672

INCLINED RETORTS.

Laclede Fire Brick Manuf'g Co., St. Louis, Mo.....	636
--	-----

GASHOLDER TANKS.

W. C. Whyte, New York City.....	674
J. P. Whittier, Brooklyn, N. Y.....	679

GASHOLDER PAINT.

The Government Waterproof Paint Co., Boston, Mass.....	672
--	-----

RETORTS AND FIREBRICK.

J. H. Gautier & Co., Jersey City, N. J.	682
B. Kreischer & Sons, New York City.....	682
Adam Weher, New York City.....	682
Laclede Fire Brick Manuf'g Co., St. Louis, Mo.....	682
Brooklyn Retort and Fire Brick Works, Brooklyn, N. Y.....	682
Borgner & O'Brien, Phila., Pa.....	682
James Gardner, Jr., Pittsburgh, Pa.....	682
Henry Maurer & Son, New York City.....	683
Chicago Retort and Fire Brick Co., Chicago, Ills.....	682
Baltimore Retort and Fire Brick Co., Baltimore.....	682
Oakhill Gas Retort and Fire Brick Co., St. Louis, Mo.....	682
Boston Fire Brick Works, Boston, Mass.....	682

SCRUBBERS AND CONDENSERS.

G. Shepard Page, New York City.....	640
R. D. Wood & Co., Phila., Pa.....	686

REGENERATIVE FURNACES.

Bartlett, Hayward & Co., Baltimore, Md.....	685
Fred. Bredel, New York City	683
Chicago Retort and Firebrick Co., Chicago, Ills.....	682
J. H. Gautier & Co., Jersey City, N. J.....	683

GAS GOVERNORS.

Connelly & Co., New York City.....	679
Fred. Bredel, N. Y. City.....	683
Friedrich Lux, London, England.....	671

SELF-SEALING MOUTHPIECE DOORS.

Smith & Sayre Mfg. Co., New York City.....	686
--	-----

TAR AND CARBONIC ACID EXTRACTOR.

Geo. Shepard Page, N. Y. City.....	676
------------------------------------	-----

CEMENTS.

C. L. Gerould & Co., Brooklyn, N. Y.....	682
--	-----

GAS ENRICHERS.

Standard Oil Co., Cleveland, Ohio.....	688
--	-----

GAS METERS.

John J. Griffin & Co., Phila., Pa.....	690
American Meter Co., New York and Philadelphia.....	691
The Goodwin Gas Stove and Meter Co., Philadelphia, Pa.....	691
Helme & McIlhenny, Phila., Pa.....	691
D. McDonald & Co., Albany, N. Y.....	691
Nathaniel Tufts, Boston, Mass.....	690
Maryland Meter and Manufacturing Co., Baltimore, Md.....	672
Bell & Jones, Philadelphia, Pa.....	690
Harris Bros. & Co., Philadelphia, Pa.....	690

EXHAUSTERS.

The P. H. & F. M. Roots Co., Connersville, Ind.....	678
Smith & Sayre Manufacturing Co., New York City.....	686
Wilbraham Bros., Philadelphia, Pa.....	679
Connelly & Co., New York City.....	679

GAS COALS.

Penn Gas Coal Co., Phila., Pa.....	689
Perkins & Co., New York City.....	688
Newburgh Orrel Coal Co., Baltimore Md.....	689
Despard Coal Co., Baltimore, Md.....	689
Chesapeake and Ohio R. R. Coal Agency, N. Y. City.....	689
Westmoreland Coal Company, Phila., Pa.....	689
J. & W. Wood, New York City.....	688

CANNEL COALS.

Perkins & Co., New York City..... 688
 J. & W. Wood, New York City..... 688

VALVES.

Ludlow Valve Manufacturing Co., Troy, N. Y..... 680
 John McLean, New York City..... 680
 Chapman Valve Manufacturing Co., Boston, Mass..... 680
 R. D. Wood & Co., Phila., Pa..... 686
 The P. H. & F. M. Roots Co., Connersville, Ind..... 678

GAS ENGINES.

Schleicher, Schumm & Co., Phila., Pa..... 656
 Clerk Gas Engine Co., Phila., Pa..... 680
 Van Duzen Gas Engine Co., Cincinnati, Ohio..... 680

ENGINES AND BOILERS.

Jarvis Engineering Co., Boston, Mass..... 679
 Ball Engine Co., Erie, Pa..... 672

STEAM PUMPS.

Van Duzen & Tift, Cincinnati, Ohio..... 671

GAS LAMPS.

Welsbach Incandescent Gas Light Co., Phila., Pa..... 673
 The Siemens-Lungren Company, Philadelphia, Pa..... 673
 Fiske, Coleman & Company, Boston, Mass..... 682

PURIFIER SCREENS.

John Cahot, New York City..... 680
 Bartlett, Hayward & Co., Baltimore, Md..... 680

GAS STOVES.

American Meter Co., New York and Philadelphia..... 675
 The Goodwin Gas Stove and Meter Co., Phila. Pa..... 692
 George M. Clark & Company, Chicago, Ills..... 673
 D. McDonald & Co., Aihany, N. Y..... 691
 Maryland Meter and Manufacturing Co., Baltimore, Md..... 672
 Bell & Jones, Philadelphia, Pa..... 690
 Chicago Gas Stove Company, Chicago, Ills..... 672

STREET LAMPS.

J. G. Miner, Morrisania, New York City..... 635
 Bartlett Street Lamp Man'fg Co., New York City..... 671

BURNERS.

C. A. Gefroerer, Phila., Pa..... 683
 H. W. Rappleye, Philadelphia, Pa..... 368

STEAM BLOWER FOR BURNING BREESE.
 H. E. Parson, New York City..... 680

PURIFYING MATERIAL.

Connelly & Co., New York City..... 679
 Friedrich Lux, London, England..... 671
 Edgewater Lime Works, Edgewater, N. J..... 671

COKE CRUSHER.

C. M. Keifer, Columbus, Ind..... 689

ELECTRICAL APPARATUS.

Wm. Henry White, N. Y. City..... 687

BOOKS, ETC.

Gerould's System Gas Bookkeeping..... 672
 1889. Directory. 1889..... 676
 King's Treatise..... 681
 Scientific Books..... 683
 Management of Small Gas Works..... 680
 Gas vs. Electricity..... 672
 Practical Electric Lighting..... 676
 Electric Light Primer..... 676
 American Gas Engineer and Superintendents' Handbook... 689
 Digest of Gas Law..... 671
 Fuel and its Applications..... 671
 Newbigging's Handbook..... 683

Position Wanted

As Superintendent or Assistant of a Gas Works,
 By a man who can give the best of references. Thoroughly
 understands the manufacture and distribution of gas and the
 construction of works. Address
 779-5 "M.," care this Journal.

POSITION WANTED

As Superintendent of Gas Works.

Eleven years' experience in the manufacture of coal gas. Best
 of references given.
 W. L. CARVER, Supt.,
 Carthage, Mo.
 778-8

WANTED,

By a New England Gas Company,

**A Man to Repair Meters, take
 Meter Readings, etc.**

776-5 Address "H. R.," care this Journal.

FOR SALE,

**The Ironwork for Twelve Benches of 6's, vis.:
 Cast Iron Hydraulic Main.**

**7-inch Dip-Pipes, Stand-Pipes, and Bridge-
 Pipes, complete.**

Floyd Mouthpieces and Self-Sealing Lids, 15x26 in.

Lids and Mouthpieces only in use over a year. Will be sold
 cheap. ISAAC C. BAXTER,
 772-tf Detroit (Mich.) Gas Lt. Co.

FOR SALE.

A Complete Water Gas Plant.

60,000 Cu. Ft. Daily Capacity.

Fully equipped; all the latest improvements; includes Gener-
 ator, Purifiers, and Holder. Can be removed to any part of the
 country, and set up at small cost. For further information ap-
 ply to BRADFORD GAS LT. & HEATING CO., Dunkirk, N. Y

FOR SALE,

**One Eight-Inch Steam Jet
 Exhauster.**

Kerr Murray make, and one of the best. Address
 J. B. HOWARD, Supt. Key City Gas Co.,
 776-tf Dubuque, Iowa.

Fuel and Its Applications.

By E. J. MILLS, D.Sc. F.R.S., and F. J. ROWAN, C.E., assisted
 by others, including Mr. F. P. Dewey, of the
 Smithsonian Inst, Wash., D. C.

7 PLATES, AND 607 OTHER ILLUSTRATIONS. ROYAL
 OCTAVO, PAGES XX, 802. HANDSOME CLOTH, \$7.50.

A. M. CALLENDER & CO., 42 Pine St., N. Y.

Simpkin & Hillyer

RICHMOND, VA.

MANUFACTURERS OF

Gas Works Apparatus

BENCH CASTINGS, CONDENSERS,

Scrubbers, Purifiers, Dry Center Seals,

FOUR-WAY VALVES, GAS VALVES,

**SULPHATE OF AMMONIA APPARATUS,
 TANKS, ENGINES, BOILERS,
 PUMPS, ETC., ETC.**

Plans, Specifications and Estimates furnished for new works,
 or alteration of old works. Correspondence solicited. Works,
 Newport News, Va.

Bartlett Street Lamp Mfg. Co.

MANUFACTURERS OF

Globe Lamps,

FOR

Streets, Parks, Public
 Buildings, Railroad
 Stations, etc.

LAMP POSTS

A Specialty.



Office and Salesroom,

40 & 42 COLLEGE PLACE, - - N. Y. CITY.

Gas Companies and others intending to erect Lamps
 and Posts will do well to communicate with us.

**VAN DUZEN'S
 STEAM JET PUMP**

For MILLS, FACTORIES, SHOPS, ETC.
 For Elevating and Conveying Liquids.
 For Emptying Pits, Sinks, Cesspools, etc.,
 and as a Fire Pump.
 10 Sizes. \$7 to \$75. Every Pump warranted.
 Write for Descriptive Book to VAN DUZEN
 & TIFT, 106 E. Second St., CINCINNATI, O.

FRIEDRICH LUX,

Ludwigshafen am Rhein and London.

Lux Mass,

GAS GOVERNORS,

Gas Balance.

EDGEWATER LIME WORKS

Chas. F. McKenna, Proprietor.

SHELL LIME.

Lime by the Cargo for Gas Purification.

EDGEWATER, BERGEN CO., N. J.

Write for Testimonials and Prices.

**GREENOUGH'S
 "DIGEST OF GAS LAW."**

Price, \$5.00.

This is a valuable and important work, a copy
 of which should be in the possession of every gas
 company in the country, whether large or small.
 As a book of reference it will be found invaluable.
 It is the only work of the kind which has ever
 been published in this country, and is most com-
 plete. Handsomely bound. Orders may be sent to

A. M. CALLENDER & CO.,

42 Pine Street, N. Y.

F. D. HARMON, PRES.

CHAS. C. ALLEN, SEC. AND TREAS.

P. W. MACKENZIE, CHIEF ENGR.

THE FUEL GAS AND LIGHT IMPROVEMENT CO.

OF AMERICA.

Owner of the Mackenzie Patents of Dec. 31, 1889, and later dates.

For the United States, England, Russia, France, Germany, Austria, and Canada,

No. 32 Park Place, New York City.

This SYSTEM is an ABSOLUTELY NEW DEPARTURE IN THE MANUFACTURE OF FUEL AND ILLUMINATING GAS. The COST OF GAS IN THE HOLDER by our System is at least THIRTY PER CENT. LESS than that made by any other process of the day. The Gas contains neither SULPHUR nor other impurities, nor is there any resultant LAMPBLACK OR TAR RESIDUUM. The Gas is manufactured WHOLLY from LIQUID HYDROCARBONS, such as Lima, Penn. Crude, and Fuel Oils, Naphtha, etc. Neither PERISHABLE PIPES nor other RETORTS, NOR THEIR EQUIVALENTS, are used.

Neither COAL, COKE, nor any other HARD CARBONS enter into the manufacture or composition of the Gas, thereby requiring LESS LABOR THAN ANY OTHER METHOD. The APPARATUS is extremely SIMPLE, SUBSTANTIAL, and DURABLE.

Works under our system may be CONTINUOUS or ALTERNATING. If alternating, the Nitrogen present will be less than 4½ per cent. If continuous, the limited amount of Nitrogen present is neutralized by Carbon.

One gallon of Lima oil by our process EQUALS ALL THE COAL required for making 1,000 feet of carbureted Water Gas.

CHARLES E. DICKEY.

JAMES B. SMALLWOOD.

CHARLES H. DICKEY.

THE MARYLAND METER AND MANUFACTURING CO.

Established 1866.

BALTIMORE, North & Saratoga Sts.

CHICAGO, 197 Michigan Street.

NEW YORK, 766 Broadway.

BOSTON, 4 Central Street.

ST. LOUIS, 1115 Olive Street.

SAN FRANCISCO, 330 Pine Street.

CONSUMERS' & STATION METERS, PRESSURE GAUGES, Etc., Etc.

"Success" and "Perfect" Gas Stoves.

BALL AUTOMATIC CUT OFF ENGINE
MADE ONLY BY THE BALL ENGINE CO. ERIE PA.

GEROULD'S

System Gas Bookkeeping.

Approved and adopted by many of the prominent Gas Engineers of the Country.

Sample Sheets and Price-List furnished free on application to

L. P. GEROULD, - - Mendota, Ill.

GAS vs. ELECTRIC LIGHT.

We would invite attention to the able and exhaustive argument of General A. Hickenlooper, President of the Cincinnati Gas Light and Coke Company, contained in a handsome pamphlet of 96 pages, entitled

"EDISON'S INCANDESCENT ELECTRIC LIGHTS FOR STREET ILLUMINATION. REPORT OF AN ARGUMENT DELIVERED BY A. HICKENLOOPER BEFORE THE COMMITTEE ON LIGHT, MUNICIPAL COUNCIL, CITY OF CINCINNATI, JULY 22, 1886."

This is a subject of special interest to all Gas Light Companies.

Prices.

25 copies.....	\$7.50	100 copies.....	\$22.50
50 copies.....	12.50	250 copies.....	50.00

A sample copy will be sent by mail on receipt of 50 cts.

A. M. CALLENDER, & CO., 42 PINE ST., N. Y. CITY

GASHOLDER PAINT.

Use Only

THE GOVERNMENT WATERPROOF PAINT.

Proof against Ammonia, and Absolutely Waterproof. Send for Prices and Particulars.

THE GOVERNMENT WATERPROOF PAINT CO., 122 Milk Street, Boston, Mass.



CHICAGO GAS STOVE CO.

MANUFACTURERS OF ALL KINDS OF

Gas Cooking and Heating APPLIANCES.

117-119 Lake St., CHICAGO.

Send for Catalogue.

PATENTS.

FRANKLIN H. HOUGH

Solicitor of American & Foreign Patents.

925 F. ST., WASHINGTON, D. C.

(NEAR U. S. PATENT OFFICE.)

Personal attention given to the preparation and prosecution of applications for Letters Patent. All business before the U. S. Patent Office attended to for moderate fees. **No Agency in the United States possesses superior facilities for obtaining Patents**, or for ascertaining the patentability of inventions. Copies of patents furnished for 25 cents each. Correspondence solicited.



THE NEW HANDY BINDER.

This article may be described as elegant in appearance, strong, durable, and possessing many special qualities of its own. It allows the opening of the pages perfectly flat, whether one or several numbers are in the binder. Any number can be taken out and replaced without disturbing the others. The papers are not mutilated for subsequent binding in permanent form. The binder is supplied with gilt side title, and is an ornament to any desk or reading table. The JOURNAL, filed in the Handy Binder, becomes a volume of great value, always convenient for instant reference. **Handy Binder, Postage paid, \$1.00.**

A. M. CALLENDER & CO., 42 Pine St., N. Y.

The Gordon Portico Lamp.

A successful Competitor of the Arc Electric Light for lighting Store Fronts, Show Windows, Depots, Railway Sheds, etc., etc.

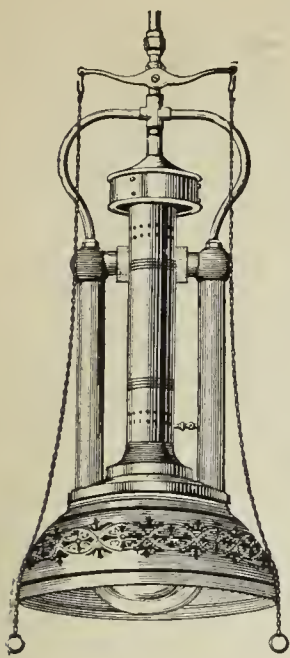

Gordon Portico Lamp.

The Gordon Street Lamp.

A Successful Competitor of the Arc Electric Light for lighting Streets, etc., etc.

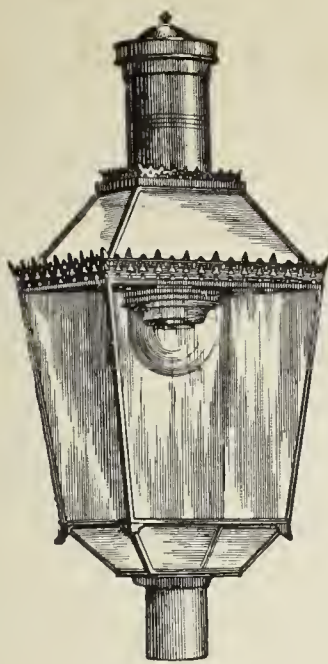

Gordon Street Lamp.

The Lungren Lamp.

A Successful Competitor of the Incandescent Electric Light for Interiors, etc. Is especially applicable for the lighting of Offices, Stores, Factories, Mills, Show Windows, Libraries, and all situations where an increased illumination is desired.

More than 25,000 Lungren Lamps are now in use. Testimonials, references, or any desired information will be cheerfully given.

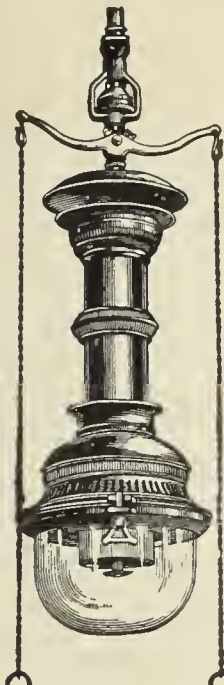

Lungren Lamp.

THE SIEMENS-LUNGREN CO., N.E. Cor. 21st St. & Washington Av., PHILADELPHIA.

WELSBACH SYSTEM OF Incandescent Gas Lighting.

OFFICE, DREXEL BUILDING, PHILA., PA.

At the Fall Session of the Board of Supervisors of Winnebago County, held at the County Court House, Oshkosh, Wis., Nov. 26, 1889, the report submitted by Mr. C. W. Cook, Chairman of the Committee on Public Buildings, recommending the use of the Welsbach Incandescent Gas Burner in the Buildings under their charge, was unanimously adopted, because of the extreme economy in the consumption of Gas and the superior character of the light obtained.

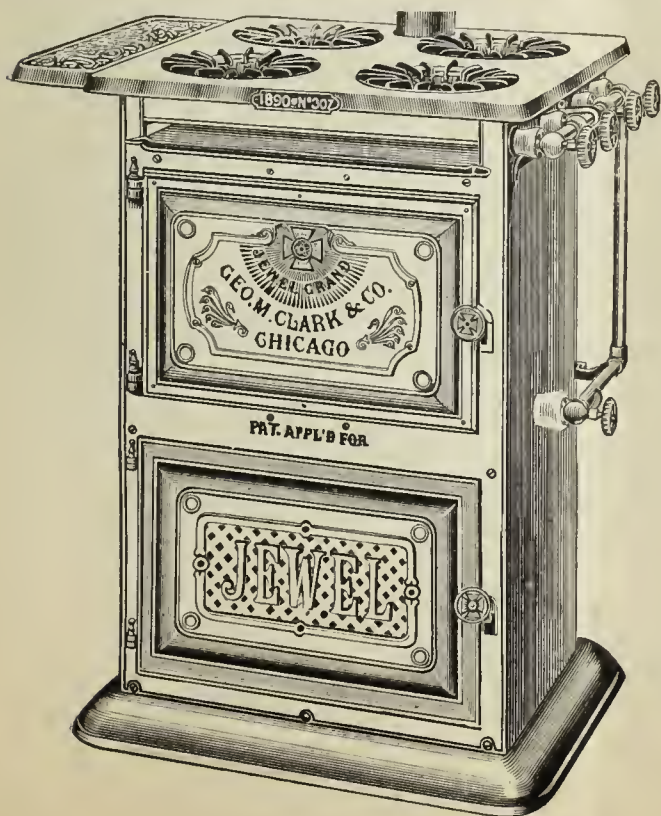

JEWEL GAS STOVES

MANUFACTURED BY

GEORGE M. CLARK & COMPANY,

Nos. 157 & 159 Superior Street, - - - Chicago, Ill.

EVERY CONCEIVABLE SIZE AND STYLE,

Ranging in Prices from \$1.50 to \$30.00.

WE USE NO GAS COCKS.

All Flames are Regulated by a Direct Needle Valve.

The JEWEL

IS THE

Only Well-Made Gas Stove on the Market.

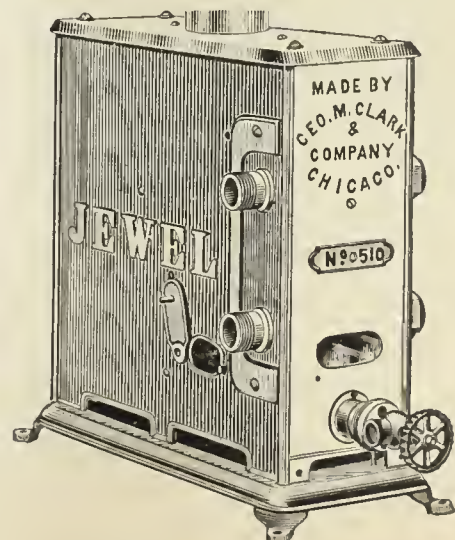

Jewel Circulating Water Heater.

Write for our 1890 Catalogue and see for yourself.

NATIONAL GAS LIGHT AND FUEL CO.,

218 La Salle Street, Chicago.

C. D. HAUK, Prest. & Gen'l Manager. A. W. GREEN, Vice-Prest. N. A. McCLARY, Sec. & Treas. E. E. MORRELL, Engr.

GAS WORKS

Built, Remodeled, Leased, and Purchased.

71 Springer Cupolas have been installed in the U. S. during the past four years.

The total capacity of Springer Apparatus now in use is over 25,000,000 ft. daily.

THE SPRINCER CUPOLA SYSTEM

Has Proven Itself the most Economical and Satisfactory Method of Gas Manufacture ever brought to the attention of the Gas Fraternity.

GUARANTEED ESTIMATES of Cost of Gas Furnished on Application.

GASHOLDER TANK CONSTRUCTION, ETC.

Gas Companies and others about to erect Gasholders will find it profitable to consult W. C. Whyte, who for over 30 years has made a specialty of

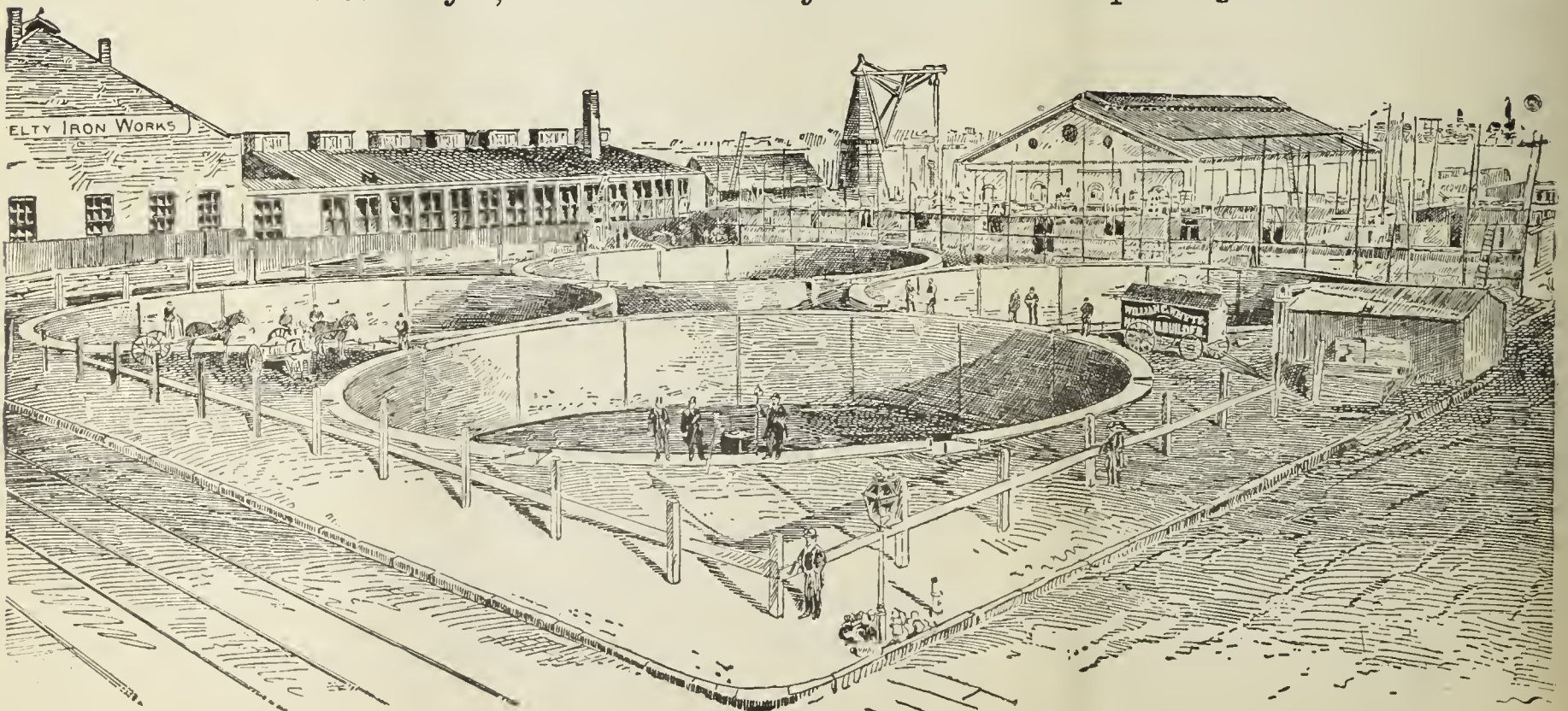

Tank Excavation and Mason Work.

Fifty Tanks now in operation show the sort of work done. Address

W. C. WHYTE. - No. 15 Cortlandt Street, N. Y. City.

GAS STOVES.

GAS METERS.

GAS STOVES.

THE AMERICAN METER CO.,

Established 1834.

Incorporated 1863.

MANUFACTURERS OF

GAS METERS, Station Meters,

METER PROVERS, PHOTOMETERS,

PRESSURE GAUGES OF ALL KINDS,



Standard 3 Diaphragm Dry Meter



Standard 2 Diaphragm Dry M

AND

Apparatus for Testing the Quantity and Quality of Gases.

GAS STOVES FOR HEATING AND COOKING

Sole Agents in the United States for

Verity's Patent Gas Fires.

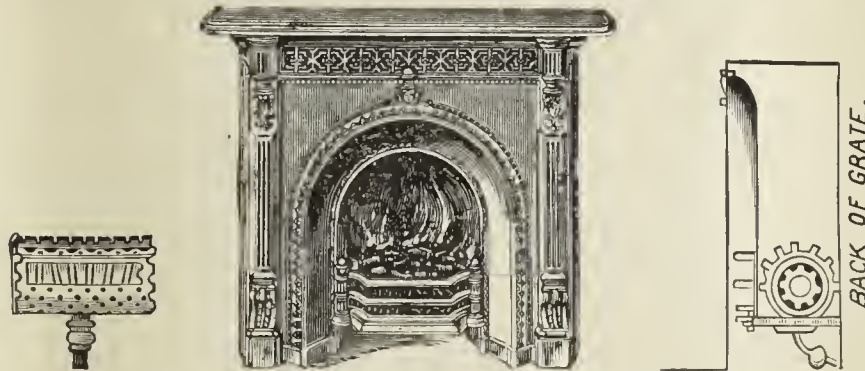

Circulars and Price Lists on Application.

MANUFACTORIES,

508 to 514 West Twenty-second St., N. Y.

Arch and Twenty-second St., Phila.

Nos. 244 & 246 North Wells Street, Chicago, Ill.

AGENCIES,

No. 177 Elm Street, Cincinnati, Ohio.

No. 222 Sutter Street, San Francisco, Cal.

No. 810 North Second Street, St. Louis, Mo.

GAS STOVE SHOW ROOMS, No 242 Sixth Avenue, New York City.

THE WALKER TAR AND CARBONIC ACID EXTRACTOR.

A very general demand exists, in both large and small Gas Works, for an apparatus that will be absolutely efficient in the removal of the tar which passes the hydraulic main and condenser. Many attempts have been made to accomplish this, but, I believe, without success, until the introduction, five years ago, in England, of the C. & W. Walker Patent Tar and Carbonic Acid Extractor. During these years this apparatus has been adopted by many of the most prominent Engineers, not only in England, but also on the Continent of Europe and in other parts of the world. It is only necessary to give here a partial list in order to convince any intelligent American Gas Engineer that this machine must have succeeded fully in accomplishing the desired results.

The following Engineers have personally given permission to refer to them:

G. C. Trewby, Esq., Engineer-in-Chief of the Gas Light and Coke Co., London. The manufacturing plant at Beckton is built in complete sections of 3,000,000 cubic feet capacity each. A Walker Tar Extractor has been fitted to each one of these sections. This was done after a long and thorough trial on one of its sections. The Tar Extractor has been supplied to other works of the Gas Light and Coke Co., including those of which John Methven, Engineer of the Gas Light and Coke Co. at the Nine Elms Station, is in charge. Also to G. E. Stevenson, Peterborough Gas Works; B. Green, Mitcham and Wimbledon Gas Works; W. H. Smith, Bedford Gas Works; F. Linging, Norwich Gas Works; J. T. Browning, Colchester Gas Works; S. B. Darwin, Portsmouth Gas Works; J. McCrae, Dundee Gas Works; W. J. Wells, Stamford Gas Works; J. M. Darwin, Longton Gas Works; J. Paterson, Warrington Gas Works; and J. Coulter, of the Dundalk Gas Works. All of the foregoing gas works are located in Great Britain.

Mr. Charles A. Gerdenier, Superintendent of the Bridgeport (Conn.) Gas Light Company, writes as follows, under date of Dec. 3, 1887:

"The C. & W. Walker Tar and Carbonic Acid Extractor has been in operation at these works for the past six weeks, and is an unqualified success. It removes every particle of Tar from the gas in once passing through the apparatus, and a large percentage of the Carbonic Acid. I also feel quite sure that it prevents the formation and deposit of Naphthaline, because since I started the Washer I have had no stoppages from this cause. These works have been seriously troubled with Tar for many years, and I have used several kinds of apparatus and every expedient which has come to my attention for dealing with the difficulty, but without success. The Walker apparatus occupies comparatively small space, is less expensive than other systems, and requires but little attention. I carry 2½-inch seal, and have an automatic tar delivery valve. This Tar Extractor is indispensable to gas makers."

I have taken the Agency for the United States for this apparatus, and am now prepared to make contracts to erect it on the premises of any Gas Company. It would be manufactured in the following sizes:

No. 1,	50,000 to	100,000	cu. ft. per 24 hrs.,	3 ft. square,	5 ft. deep.
No. 2,	" "	125,000	" " "	4 " " "	" "
No. 3,	" "	250,000	" " "	5 " " "	" "
No. 4,	" "	500,000	" " "	6 " " "	" "
No. 5,	" "	750,000	" " "	7 " " "	" "
No. 6,	" "	1,000,000	" " "	8 " " "	" "
No. 7,	" "	1,250,000	" " "	9 " " "	" "
No. 8,	" "	1,500,000	" " "	10 " " "	" "
No. 9,	" "	2,000,000	" " "	12 " " "	" "
No. 10,	" "	3,000,000	" " "	15 " " "	" "

This Tar Extractor will perform its work with about one-fourth the usual back-pressure heretofore required. It is simple in construction, and can be supplied at a very reasonable price—less than any other ever before introduced. Satisfactory results will be guaranteed in every instance.

GEO. SHEPARD PAGE,

SOLE AGENT FOR THE UNITED STATES,

No. 69 Wall Street, - - - New York,

THE UNITED GAS IMPROVEMENT CO.

Drexel Building,

CHESTNUT AND FIFTH STREETS,

PHILADELPHIA, PA.

OFFICERS:

WILLIAM W. GIBBS, President.

GEORGE PHILLER, Vice-President.

SAM'L T. BODINE, Gen'l Manager.

RANDAL MORGAN, Gen'l Counsel.

EDWARD C. LEE, Sec'y and Treas.

ALEX. C. HUMPHREYS, Gen'l Supt.

WALTON CLARK, Ass't Gen'l Supt.

H. H. EDGERTON, Chem. and Eng'r.

DIRECTORS:

GEORGE PHILLER,

THOMAS DOLAN,

HENRY C. GIBSON,

WM. T. CARTER,

WILLIAM G. WARDEN,

SAM'L T. BODINE.

BUILDERS, LESSEES AND PURCHASERS OF

➤ GAS WORKS. ➤

ROOTS' GAS AND BYE-PASS VALVES.

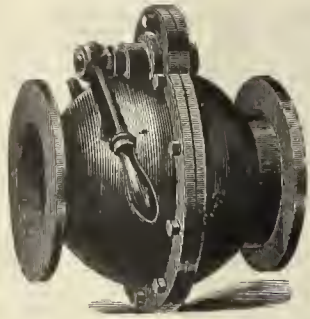

GAS VALVE

Quick Acting,
Simple,
Efficient, Durable.



BYE-PASS VALVE.

Automatic Action
Reliable
Simple Durable.

Thousands now in use and giving perfect satisfaction. Write for Catalogue and Prices.

ROOTS' NEW GAS EXHAUSTER.

Unsurpassed
for Neatness
of Design,
Durability,
Simplicity,
Efficiency,
and Economy
of Power.

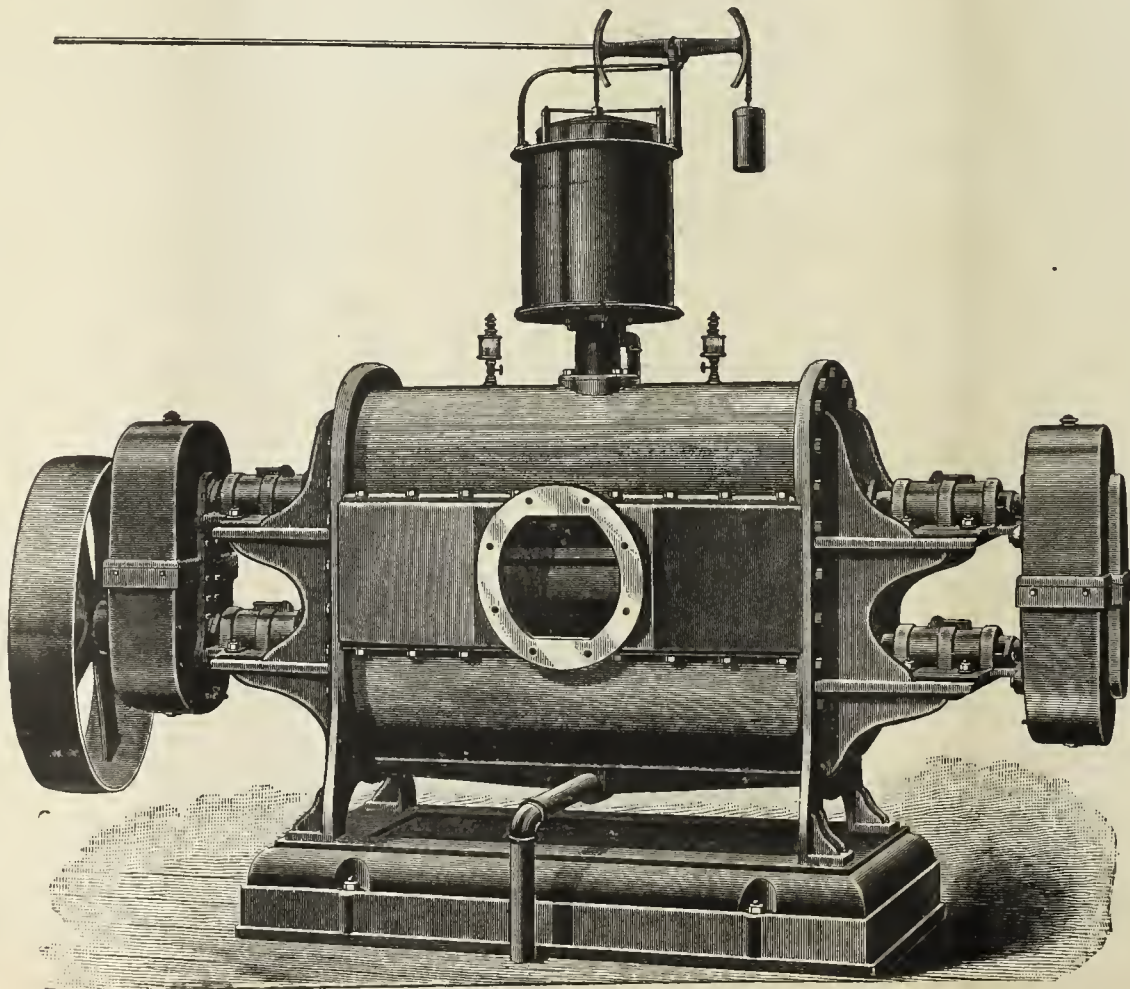

All Parts
Requiring
Attention
are External
and Easily
Accessible
at all Times.

Send for Descriptive Catalogue and Price List.

THE P. H. & F. M. ROOTS CO., Patentees and Manufacturers, **CONNERSVILLE, IND.**

S. S. TOWNSEND, Gen. Agt., 22 Cortlandt St., N. Y. COOKE & CO., Selling Agts., 22 Cortlandt St., N. Y.

CONNELLY & CO.,

SOLE MANUFACTURERS OF THEIR PATENTED SPECIALTIES.

"IRON SPONGE."

Saves money, saves labor, and is the most efficient purifying agent ever offered as a substitute for lime. Now used in every State in the Union, and purifying daily over thirty-five million cubic feet. Should be used in every gas works. Its own saving will pay for it many times over.

AUTOMATIC GOVERNOR.

Has been on the market but three years, and in that time has been introduced more generally than any invention ever designed for use in gas works. Over two hundred of them now in use. Sensitive; reliable; perfectly automatic; reduces leakage; satisfies consumers, and gives great relief to the Manager. No gas works is complete without one of these machines.

STEAM JET EXHAUSTER.

Designed particularly for small works. Combines Exhaust Tube, Steam Governor Gas Compensator, and Bye-Pass Valves in the most compact form possible; occupies but little space; uses very little steam; operated by ordinary workmen; saves formation of carbon in retorts; increases yield 10 to 15 per cent. Specially adapted for mixing air with oil gas. No works too small to use them profitably.

Prices given on all our specialties delivered at any point in the United States. Correspondence solicited.

CONNELLY & CO., No. 111 Broadway, New York City.

WILBRAHAM GAS EXHAUSTER & ENGINE COMBINED.

WILBRAHAM BROS.,
PHILADELPHIA, PA.

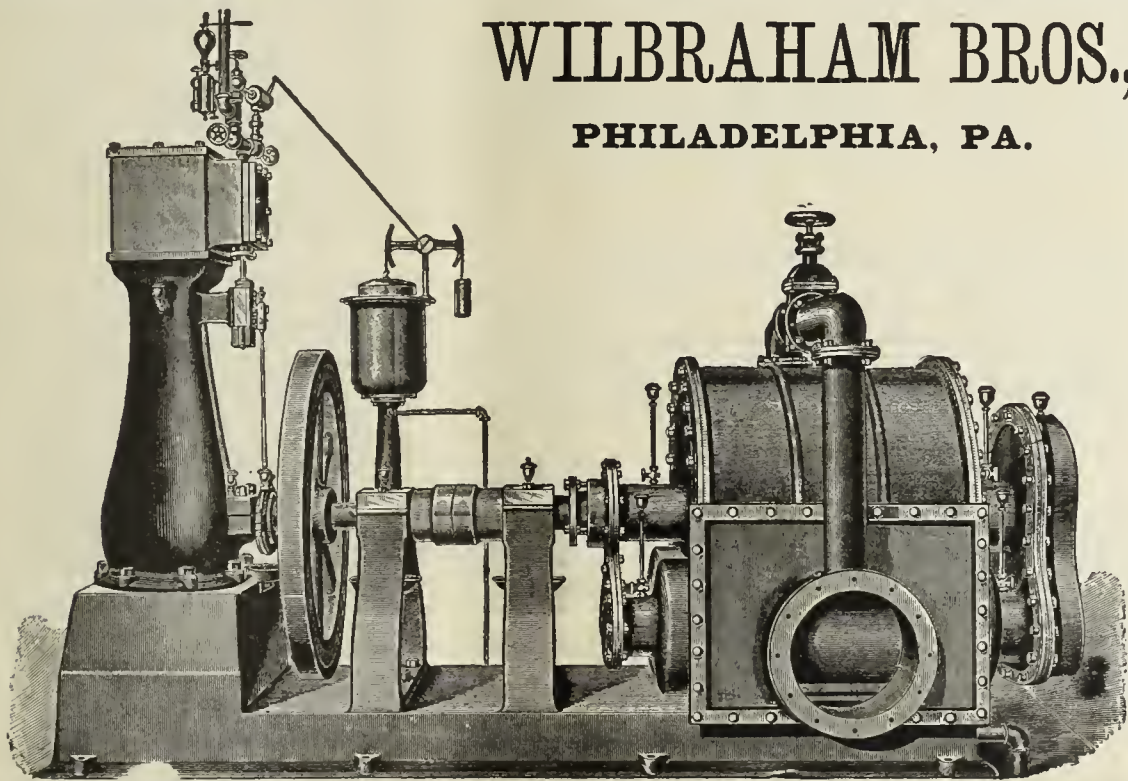

JARVIS ENGINEERING CO.,

61 Oliver St., Boston, Mass.

CONTRACTORS FOR ERECTING

COMPLETE STEAM OUTFITS FOR ELECTRIC LIGHTING STATIONS.

Steel Boilers set with Jarvis Pat. Boiler Setting

To burn COKE SCREENINGS for Fuel.

ARMINGTON & SIMS CO. ENGINES,

Belting direct to Dynamos, without using Shafting.

SEND FOR CIRCULARS.

REFERENCES.—Charlestown Gas & Electric Light Co., Charlestown, Mass.; Schenectady Gas & Electric Light Co., Schenectady N. Y.; Brookline Gas Co., Brookline, Mass.

Practical Electric Lighting

By A. BROMLEY HOLMES, A.M.I.C.E.

With 87 Illustrations. Third Edition. Price, \$1.00.

Electric Light Primer.

By CHARLES L. LEVEY.

A simple and comprehensive Digest of all the most important facts connected with the running of the Dynamo and Electric Lights, with Precautions for Safety, etc.

Price, 50 cents.

A. M. CALLENDER & CO., 42 Pine St., N. Y.

Gasholder Tanks & Gas Works Masonry Complete.

PLANS PREPARED AND ESTIMATES FURNISHED AT SHORT NOTICE.

J. P. WHITTIER, - - 499 Wythe Av., Brooklyn, N. Y.

1889 DIRECTORY 1889

OF THE GAS LIGHT COMPANIES of the UNITED STATES & CANADA.

Price, \$8.00.

A. M. CALLENDER & CO., No. 42 Pine Street, N. Y. City.



CHAPMAN VALVE MANUFACTURING CO.,

MANUFACTURERS OF

Valves and Gates for Gas, Ammonia, Water, Etc.

Also, Gate Fire Hydrants With and Without Independent Nozzle Valve. All Work Guaranteed.

WORKS & GEN'L OFFICE:
Indian Orchard, Mass.

TREASURER'S OFFICE:
72 Kilby & 112 Milk Sts, Boston, Mass.

Parson's Steam Blower,

FOR IMPROVING BAD DRAUGHT IN BOILERS, AND FOR BURNING BREEZE OR OTHER WASTE MATERIAL.

PARSON'S TAR BURNER,

FOR UTILIZING COAL TAR AS FUEL.

PARSON'S AIR JET TUBE CLEANER,

FOR CLEANING BOILER TUBES.

These devices are all first-class. They will be sent to any responsible party for trial. No sale unless satisfactory. Manufactured by the WATERTOWN STEAM BLOWER COMPANY.

H. E. PARSON. Supt., 33 & 35 Liberty St., N.Y

MILLS' REVERSIBLE LIME TRAY,

AND

WOODWORK

Of Every Description

NEEDED BY GAS WORKS.

SEND FOR CIRCULAR AND PRICE LIST TO

BARTLETT, HAYWARD & CO.,

Pratt and Scott Streets, Baltimore, Md.

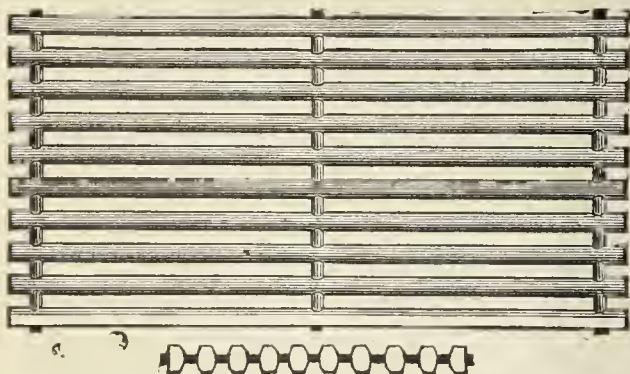

VAN DUZEN GAS & GASOLINE ENGINE

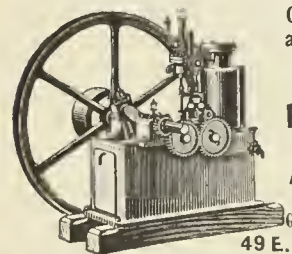

OPERATED with COAL and OTHER MANUFACTURED GASES AND GASOLINE.

RELIABLE AND ECONOMICAL.

Fully Warranted

VAN DUZEN Gas & Gasoline Engine Co. 49 E. 2d St., Cincinnati, O.

A. MacKinnon Machine Co., Agts., 22 Warren St., N.Y.

The Management of Small Gas Works.

BY C. J. R. HUMPHREYS.

Price, \$1.

Orders to be sent to A. M. CALLENDER & CO.,

42 PINE STREET, NEW YORK.

LUDLOW VALVE MFG. CO.

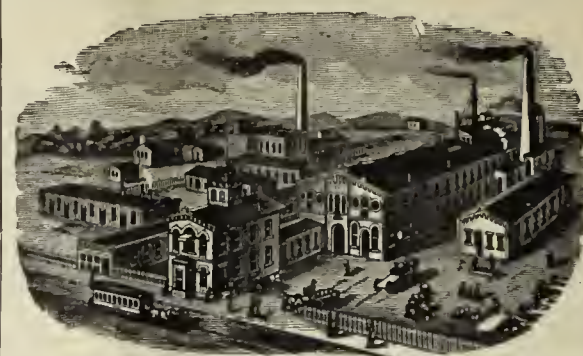

OFFICE AND WORKS,

938 to 954 River Street and 67 to 83 Vall Av., TROY, N. Y.

Hydraulic Main Dip Regulators, also Check Valves, Foot Valves, Yard-wash and Fire Hydrants. Send for Circulars.

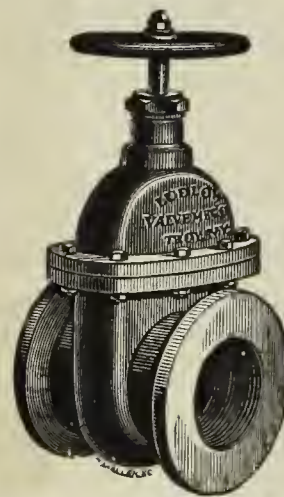

Valves.—Double and Single Gate, 1/2 in. to 48 in., outside and inside Screws. Indicator, etc., for Gas, Water, Steam, and Oil. Send for Circulars.

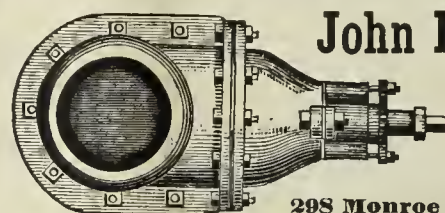

John McLean

Man'facturer

GAS VALVES.

298 Monroe Street, N. Y.

SPECIAL TRAYS FOR IRON SPONGE OR OXIDE OF IRON.

CHURCH'S TRAYS A SPECIALTY.

REVERSIBLE—STRONGEST—MOST DURABLE—MOST EASILY REPAIRED.

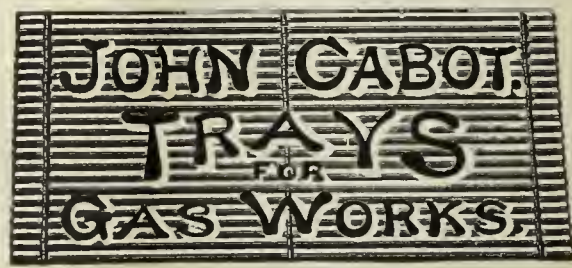

306-310 ELEVENTH AVENUE, NEW YORK.

WE ALSO MAKE THE CHEAPEST AND STRONGEST REVERSIBLE BOLTED TRAYS IN THE MARKET.

THE CLERK GAS ENGINE CO.,

Main Office, 1012, 1014, 1016, 1018 Filbert St., Philadelphia, Pa.

WM. W. GOODWIN, Prest.

E. STEIN, Sec.

S. LEWIS JONES, Asst. Sec.

A. J. DOTY, Supt.

The utility and convenience of the Gas Engine being no longer an open question, it only remains now for intending purchasers to select the BEST. We claim for the CLERK GAS ENGINE that it is equal to any other manufactured as regards steadiness in running, simplicity, and ease of keeping in repair, and that it gives the greatest amount of power for the least money (both in first cost and expense of running) of any engine made. In support of this claim we refer to the test of the Gas Engines made under the direction of the American Institute of New York, in December, 1885, and heretofore published in these columns. These engines are especially adapted for continuous running under heavy loads, and we can refer to Engines which have run 22 hours a day for months at a time!

Made in Sizes of 5, 10, 15, 20, and 25 Horse Power. All Engines Guaranteed for One Year.

ENGINEERS.

P. D. WANNER, Chairman. A. H. MELLERT, Mangr. of Wks.
R. B. KINSEY, Secretary. F. A. KNOPP, Treasurer.

MELLERT FOUNDRY & MACHINE CO. Ltd.
and **READING FOUNDRY CO., Ltd.**
Reading, Pa.



Specials—Flange Pipe, Valves and Hydrants
Lamp Posts, Retorts, etc.
General Foundry and Machine Work.
JOHN FOX, Selling Agent. 160 Broadway, N.Y.

THE OHIO PIPE COMPANY,

MANUFACTURERS OF

Cast Iron Gas & Water Pipe,
BRANCH AND SPECIAL CASTINGS.

Gas-House Bench Castings, Hydraulics, Lamp Posts, Flange Pipe
and Specials, Architectural Castings, Building Columns,
Joists, Cellar Grates, Sash Weights, etc.

GENERAL FOUNDERS AND MACHINISTS.
Columbus, Ohio.

M. J. DRUMMOND,



SPECIAL CASTINGS AND LAMP POSTS.
Office, Corbin Building, 192 Broadway, N. Y.

EMAUS PIPE FOUNDRY.

DONALDSON IRON COMPANY. EMAUS, PA.



MANUFACTURERS OF

CAST IRON PIPE AND SPECIAL CASTINGS
FOR WATER AND GAS.

JOS. R. THOMAS,

No. 42 Pine Street, N.Y. City.

CONSULTING AND CONSTRUCTING
Gas Engineer and Contractor.

PLANS, SPECIFICATIONS, AND ESTIMATES
FURNISHED.

Contracts taken for all Appliances
required at a Gas Works,
Either for New Works or Extensions to Old Plants.

WM. MOONEY

(Successor to WM. FARMER)

No. 94 Liberty St., N Y. City.

GAS ENGINEER AND CONTRACTOR FOR THE ERECTION
OF GAS WORKS, OR APPARATUS OF ANY
CAPACITY.

Plans and Specifications Furnished.

WM. GARDNER,
Gas Engineer,

Lewis Block, Room 20, Pittsburgh, Pa.

Those who intend to make alterations in existing gas plants, or
who contemplate the erection of new works, will find it to their
interest to open correspondence with the above. Plans mad
and estimates furnished.

GAS AND WATER PIPES.

SAM'L R. SHIPLEY, Pres.
HENRY B. CHEW, Tre

GLOUCESTER IRON WORKS,
GLOUCESTER CITY, N. J.



JAS. P. MICHELLON, Sec.
WM. SEXTON, Supt.

Cast Iron Gas & Water Pipes, Stop Valves, Fire Hydrants, Gasholders. &c.

Office, Rooms 61 and 63 Bullitt Building, 131 S. 4th St., Phila., Pa.

WARREN FOUNDRY AND MACHINE CO.,

Established 1856. Works at Phillipsburgh, N. J.

New York Office, 160 Broadway.

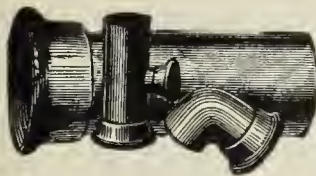

CAST IRON WATER AND GAS PIPE,

FROM TWO TO FORTY-EIGHT INCHES DIAMETER. ALSO, ALL SIZES OF

Flange Pipe for Sugar House and Mine Work. Branches, Bends, Retorts, etc., etc.

DENNIS LONG & COMPANY,

LOUISVILLE, KY.,

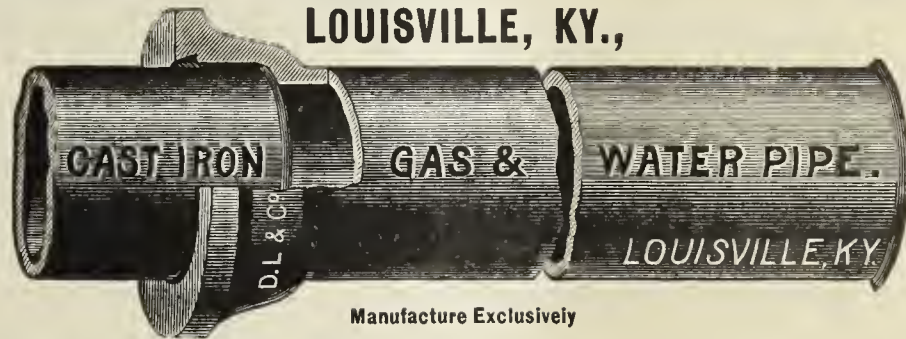

CAST IRON GAS & WATER PIPE & SPECIAL CASTINGS
OF ALL SIZES.

King's Treatise on Coal Gas.

A stand ard text-book for the Engineers and Managers of Gas Works, and for all who are concerned
or take an interest in the manufacture and distribution of Coal Gas, and in the utilization of the
Secondary Products resulting therefrom; treating also of the Gas Engine, and of Gas Cooking and
Heating Appliances.

In 3 Vols. Price per Vol., \$10. Sold either by Volume or in Sets.

A M. CALLENDER & CO., 42 Pine St., N. Y.

RETORTS AND FIRE BRICK.

J. H. GAUTIER & CO.,

CORNER OF
GREENE AND ESSEX STREETS,
JERSEY CITY, N. J.

MANUFACTURERS OF

**Clay Gas Retorts,
Gas House Tiles,
Fire Bricks, Etc. Etc.**

Ground Clay, Fire Brick and
Fire Sand in Barrels,

J. H. GAUTIER. C. E. GREGORY. C. E. GAUTIER.

BROOKLYN

Clay Retort & Fire Brick Works,
(EDWARD D. WHITE & CO.)

Manufacturers of Clay Retorts, Fire Brick,
Gas House and other Tile.VAN DYKE, ELIZABETH, RICHARDS & PARTITION STS.
Office, 88 Van Dyke St., Brooklyn, N. Y.

RETORTS AND FIRE BRICK.

LACLEDE FIRE BRICK MFG. CO.,

MANUFACTURERS OF

Fire Brick, Gas Retorts,

AND

ST. LOUIS STANDARD SEWER PIPE.Blast Furnace and Cupola Linings, every description of Fire
Clay Material, Fire Clay Flue Linings, Chimney Tops
Dry Milled and Crude Fire Clays, etc.

OFFICE AND DEPOT

901, 903, and 905 Pine Street,
ST. LOUIS, MO.

ESTABLISHED IN 1845.

B. KREISCHER & SONS,

OFFICE FOOT OF HOUSTON ST., E. R., N. Y.

Gas Retorts,**TILES, FIRE BRICK.**

AND EVERYTHING IN THE FIRE CLAY LINE.

RETORTS AND FIRE BRICK.

MANHATTAN

FIRE BRICK & ENAMELLED CLAY

RETORT WORKS**ADAM WEBER.****CLAY GAS RETORTS**

AND RETORT SETTINGS

FIRE BRICKS, TILES, ETC.,

Office and Works, 15th Street and Avenue C., N. Y.

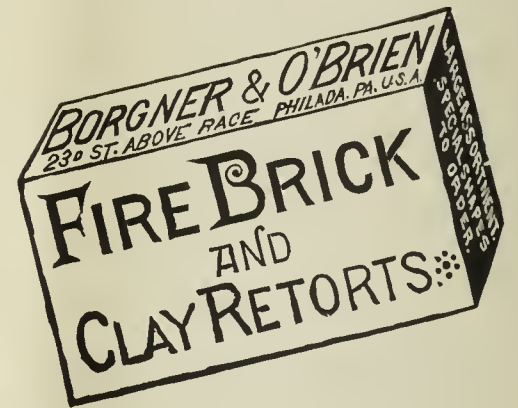

Works,

LOCKPORT STATION, PA.

—ESTABLISHED 1864.—

JAMES GARDNER, JR.,

Successor to WILLIAM GARDNER & SON.

Fire Clay Goods for Gas Works.

H. A. NORTON, No. 4 CENTRAL STREET, BOSTON, MASS., Agent for the New England States.

GEO. C. HICKS,
Prest.**CHICAGO**CHAS. A. REED,
Sec. & Treas.**Retort and Fire Brick Co.,**

MANUFACTURERS OF

Fire Clay Goods of all Kinds,

AND BEST QUALITY ONLY.

Regenerative Furnaces & Water Gas Goods.

45th St., Clark to La Salle, Chicago.

GEROULD'S IMPROVED RETORT CEMENT.A Cement for patching retorts, putting on mouthpieces, and
making up all bench-work joints. This Cement is mixed ready
or use. Economic and thorough in its work. Fully warranted
o stick. For recommendations and price list address**C. L. GEROULD & CO.,**

5 & 7 Skillman St., Brooklyn, N. Y.

Western Agent, H. T. GEROULD, Mendota, Ill.

**Parker-Russell
Mining and Mfg. Co.,**

CITY OFFICE,

Mermod-Jaccard Bldg., Rooms 307 & 308,
Broadway & Locust St., St. Louis, Mo.

PROPRIETORS OF THE

OAKHILL GAS RETORT & FIRE BRICK W'KSOur immense establishment is now employed almost entirely in
the manufacture of**Materials for Gas Companies**We have studied and perfected three important points. Our re-
torts are made to stand changes of temperature, the strongest
heats of the furnace, and the abrasion of feeding and emptying.
We have the exclusive Agency for the West of the celebrated**Kloenne-Bredel Full Depth and
Semi-Recuperator Benches,**

And also furnish and build

Our Own Styles Semi-Recuperator Furnaces
for the use of Coal or Coke as fuel.

THOS. SMITH, Prest.

AUGUST LAMBLA, Vice-Prest. & Supt.

BALTIMORE**RETORT & FIRE BRICK CO.**

MANUFACTORY AT

LOCUST POINT, BALTIMORE, MD.

Clay Retorts, Blocks & Tiles**FIRE BRICK, FIRE CLAY,
AND FIRE CEMENT.**Red and Buff Ornamental Tiles and Chim-
ney Tops. Drain and Sewer Pipe (from
2 to 30 inches). Baker Oven Tiles
12x12x2 and 10x10x2.

WALDO BROS., 88 WATER ST., BOSTON, MASS

Sole Agents the New England States.

Boston Fire Brick Works Manufacturers of **Gas Retorts and Settings**

Under the Personal Supervision of MR. GEO. C. HICKS late of Chicago.

Fire Clay Goods of all kinds. Akron Sewer Pipe, Lime, Cement, etc. Agts. for the Arc Gas Lamp & Governing Gas Burners.

Send for Circulars and Prices to

FISKE, COLEMAN & CO., Managers, No. 62 Congress Street, Boston, Mass.

HENRY MAURER & SON,

(ESTABLISHED 1856.)

**EXCELSIOR FIRE BRICK & CLAY
RETORT WORKS**

WORKS, Perth Amboy, N. J.
OFFICE, 418 to 422 East 23d St., N. Y.

**Clay Gas Retorts,
BENCH SETTINGS,
Fire Brick, Tiles, Etc.**

**FLEMMING'S
Generator-Gas Furnace**

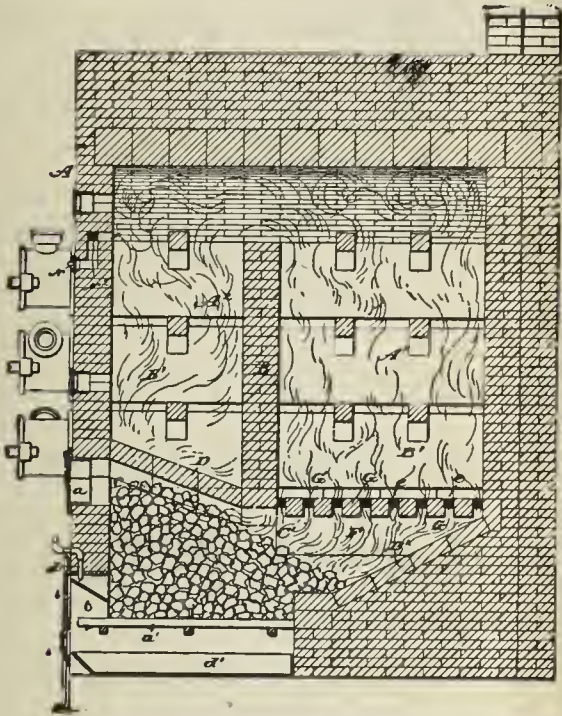

Materials furnished and Benches erected by

J. H. GAUTIER & CO., - Jersey City, N. J.

Address as above, or D. D. FLEMMING, Jersey City, N. J.

FRED. BREDEL,

CONTRACTOR FOR THE COMPLETE

Erection and Equipment of Gas Works.

SOLE PROPRIETOR OF THE

KLOENNE PATENTS

FOR NORTH AMERICA.

REGENERATIVE FURNACES.

(900 Retorts are now fired in America by the Kloenne-Bredel System.)

SELF-SEALING MOUTHPIECES.

(Over 800 Now in Use.)

Standard Condensers. Washer-Scrubbers.

TAR WASHERS FOR WATER GAS PLANTS.

(In use in the works of the Chicago Gas Lt. Co.)

GASHOLDERS.

Bredel's Automatic Gas Governor.

Refers, by permission, to Mr. Eugene Vanderpool, Newark, N. J.; Mr E. G. Cowdery, Milwaukee, Wis.; and Mr. Theo. Forstall, Chicago, Ills. For further information, address

FRED. BREDEL,

No. 208 East Seventeenth Street, N. Y. City.

SCIENTIFIC BOOKS.

KING'S TREATISE ON THE MANUFACTURE OF COAL GAS. Three vols.; \$10 per vol.

GAS MANUFACTURE, by WILLIAM RICHARDS. 4to., with numerous Engravings and Plates, in Cloth binding. \$12.

TECHNICAL GAS ANALYSIS. \$2.80.

GAS CONSUMER'S GUIDE. \$1.

A GUIDE TO GAS LIGHTING. 40 cents.

GAS MEASUREMENT AND GAS METER TESTING, by F. W. HARTLEY. \$1.60

GAS CONSUMER'S HANDBOOK, by WILLIAM RICHARDS, C.E.; 18mo., Sewed. 20 cents.

A PRACTICAL TREATISE ON GAS AND VENTILATION with Special Relation to Illuminating, Heating, and Cooking Gas, by E. E. PERKINS. \$1.25.

PRACTICAL TREATISE ON HEAT, by THOMAS BOX. Second edition. \$5.

GAS WORKS—THEIR ARRANGEMENT, CONSTRUCTION, PLANT, AND MACHINERY. \$8.

COAL; ITS HISTORY AND USE, by PROF. THORPE. \$3.50.

THE GAS WORKS OF LONDON, by COLBURN. 60 cents.

THE GAS FITTER'S GUIDE, Showing the Principles and Practice of Lighting with Coal Gas, by JOHN ELDREDGE. 40 cents.

GAS WORKS, AND MANUFACTURING COAL GAS, HUGHES. \$2.20.

THE MANAGEMENT OF SMALL GAS WORKS, by C. J. R. BUMPHREYS. \$1.

MANUAL FOR GAS ENGINEERING STUDENTS, by D. LEE, 40 cents.

HOW TO MANAGE GAS, by F. WILKINS. Paper. 20 cents.

THE DOMESTIC USES OF COAL GAS, AS APPLIED TO LIGHTING, by W. SUGG. \$1.40.

DIGEST OF GAS LAW. \$5.

DISTILLATION OF COAL TAR AND AMMONIACAL LIQUOR. by GEO. LUNGE. New Edition. \$12.50.

A TREATISE ON THE COMPARATIVE COMMERCIAL VALUES OF GAS COALS AND CANNELS, by D. A. GRAHAM 8vo., Cloth. \$3.

GAS COMPANIES DIRECTORY. \$3.

GAS VERSUS ELECTRIC LIGHT. 50 cents.

THE AMERICAN GAS ENGINEER AND SUPERINTENDENT'S HANDBOOK, by WM. MOONEY. \$3.

GAS ENGINE INDICATOR DIAGRAM, by W. E. AYRTON. Paper. 20 cents.

ILLUMINATING AND HEATING GAS, by W. BURNS. \$1.50.

TESTING PIPES AND PIPE JOINTS, by M. M. PATERSON. 80 cents.

DESIGNING WROUGHT AND CAST IRON WORK, by H. ADAMS. Paper. Three parts, 60 cents each.

NOTES IN MECHANICAL ENGINEERING, by H. ADAMS. \$1.

STRAINS IN IRONWORK, by H. ADAMS. With plates. \$1.75

The above will be forwarded by express, upon receipt of price. If sent by mail, postage must be added to above prices. We take especial pains in securing and forwarding any other Works that may be desired, upon receipt of order. All remittances should be made by check, draft, or post office money order.

A. M. CALLENDER & CO., 42 Pine Street, New York.

Newbigging's Handbook for Gas Engineers and Managers.

The present (the fifth) edition marks an important advance on those that have gone before. Considerable additions have been made to the text, and much of it has been re-written and otherwise improved. It extends to 524 pages, and contains 193 illustrations. Price, Cloth, \$6.00.

A. M. CALLENDER & CO., - - - No. 42 Pine Street, N. Y. City.

DAVIS & FARNUM MFG. CO.,

WALTHAM, MASS.

PRINCIPAL OFFICE AND WORKS, Waltham, Mass.

BOSTON OFFICE, Room 55, Mason Building, 70 Kilby Street.

SINGLE, DOUBLE,
AND
TRIPLE LIFT

Gas holders.

OF ANY CAPACITY.

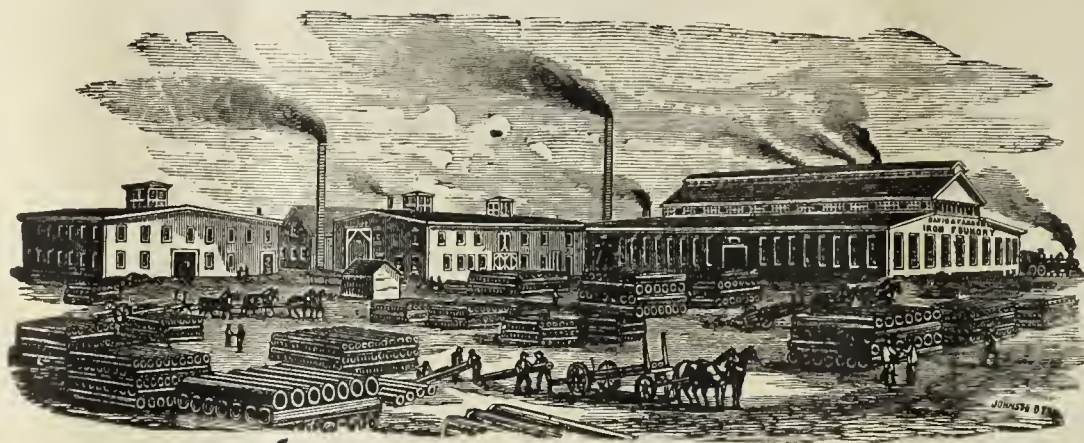

TUBULAR, PIPE,
AND
SINUOUS FRICTION

Condensers.

OF ALL SIZES.

IRON ROOF FRAMES AND FLOORS.

Purifying Boxes, Center Seal or Valve Connections, Bench Work.

Reversible Lime Trays.

SELF-SEALING AND PRESSED STEEL MOUTHPIECE LIDS.

Coke Barrows, Coal Wagons, and all Apparatus Requisite for a Complete Gas Plant.

— ALSO —

Gas and Water Pipe, Flanged Pipe,

Sugar House Work, and Special Castings of all Descriptions.

Established 1861.

Incorporated 1881.

KERR MURRAY MFG. CO.,

FORT WAYNE, IND.

Those who are in need of

Holdings of Gas Works Apparatus of any Description,

AND OF THE LATEST IMPROVEMENTS,

will find it to their interest to

GET AN ESTIMATE FROM US

before placing their order.

As we make a Specialty of this Class of Work, and are Practical Builders and Manufacturers of same,

with our long years of experience in the business,

WE CAN GUARANTEE YOU SATISFACTION.

Estimates, Plans and Specifications Furnished on Application.

BARTLETT, HAYWARD & CO.

Baltimore, Md.

Triple Double, & Single-Lift
GASHOLDERS.

Iron Holder Tanks.

ROOF FRAMES.

Cirders.

BEAMS.

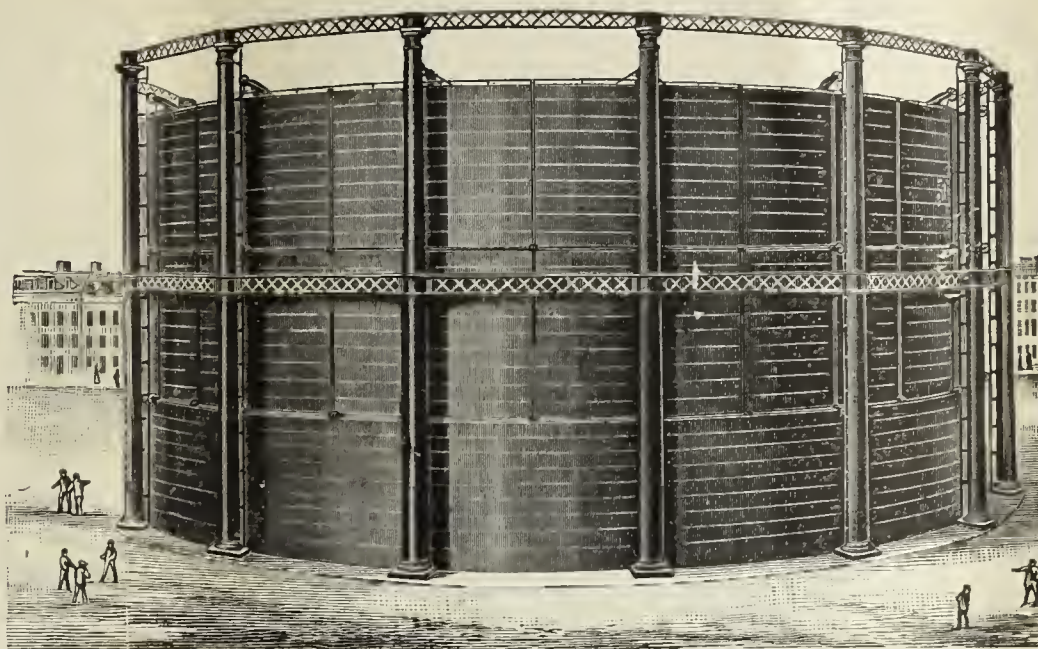

PURIFIERS.

CONDENSERS.

Scrubbers.

BENCH CASTINGS.

OIL STORAGE TANKS.

Boilers.

The Wilkinson Water Gas Process.

THIRTY-CANDLE, NON-CONDENSABLE, FIXED GAS. THE MOST SUCCESSFUL GAS PROCESS IN OPERATION.

Munich Regenerative Furnace, System Drs. Schilling & Bunte.

HAZELTON BOILERS.

Gas Works Designed and Constructed.

Pascal Iron Works. ESTABLISHED 1821. Delaware Iron Works.

MORRIS, TASKER & CO.,

INCORPORATED.

OFFICE, 224 SOUTH THIRD STREET, - - PHILADELPHIA, PA.

CONTRACTORS, BUILDERS, AND MANUFACTURERS OF

Gas, Water & Sugar Works

Bench Castings.

Condensers.

Scrubbers.

Purifiers.

Hyd. Carriages.

Iron Floors,

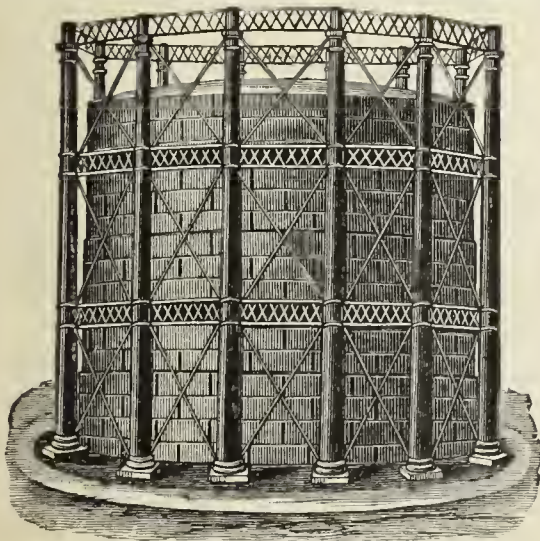

Iron Roofs.

Street Stops,

Valves, etc.

Stand-Pipes.

Water & Oil

Tanks, all Sizes.

Single, Double, and Triple-Lift Gas Holders.

SELF-SEALING RETORT LIDS. STAMPED STEEL RETORT LIDS.

Locomotive Water Columns, Filters, etc. Boiler Tubes, Wrought Iron Pipe & Fittings

Plans, Specifications and Estimates for all kinds of Machinery furnished on application.

Foundries & Works,
MILLVILLE, FLORENCE,
and CAMDEN, N. J.

R. D. WOOD & CO.,

Engineers,
Iron Founders,
and
Machinists.

400 Chestnut St., PHILADELPHIA, PA.

MANUFACTURERS OF

CAST IRON PIPE,

Gas Holders,

SINGLE, DOUBLE, AND TRIPLE LIFTS, WITH
OR WITHOUT WROUGHT IRON
OR STEEL TANKS.

PURIFIERS, CONDENSERS.

Scrubbers.

BENCH WORK.

Iron Floors and Roofs, Plate Girders.

Heavy Loam Castings.

HYDRAULIC WORK.

Lamp Posts, Valves, Etc.

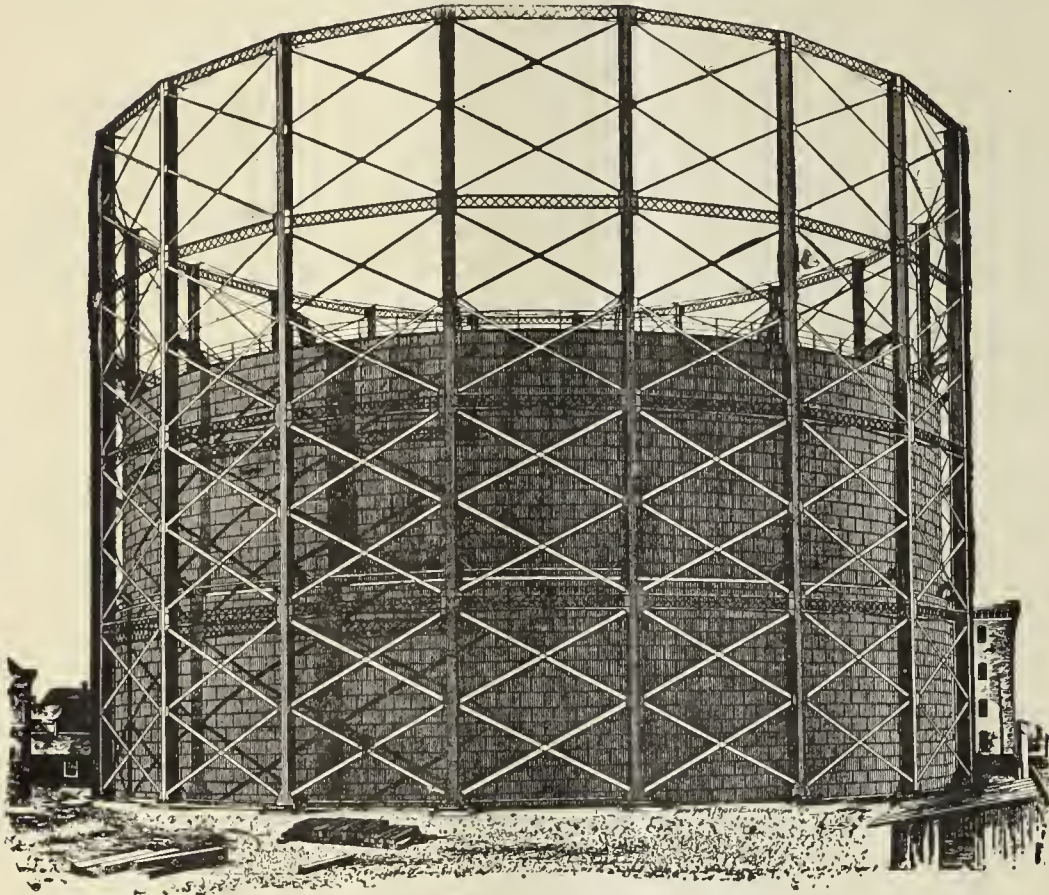

SMITH & SAYRE MFG. COMPANY,

G. G. PORTER, Prest.

245 Broadway, N. Y.

CHAS. W. ISBELL, Sec'y.

Machinery & Apparatus for Gas Works

Drawings, Plans, and Estimates Furnished for the Improvement, Extension, or Alteration of Gas Works, or for the Construction of New Works.

Mackenzie's Patent Rotary and Steam Jet Gas Exhausters, Governors, Compensators, Condensers, Washers, Scrubbers. Isbell's Patent Automatic Street Pressure Governor, Gas and Water Valves, Hydraulic Main Dip Regulator, Bench Castings, etc. Purifying Boxes and "Standard" Scrubbers, Isbell's Patent Self-Sealing Retort Doors.

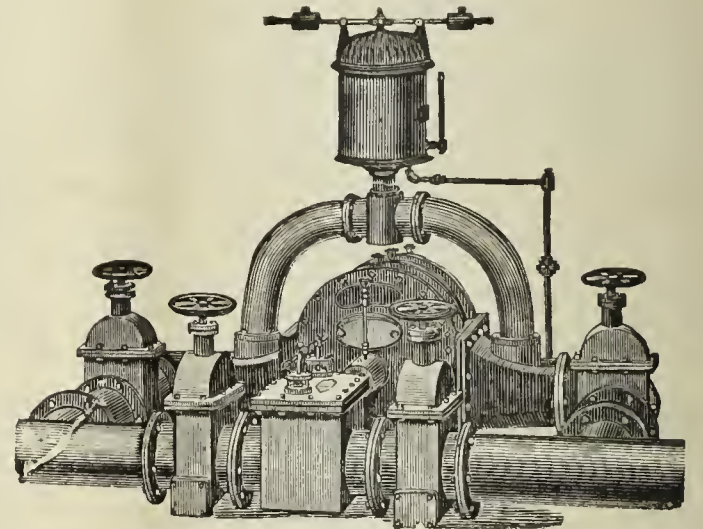

THE BRENNER SELF-SEALING RETORT DOOR.

Simple, Strong, and Durable.

CLOSES ABSOLUTELY TIGHT & IS LOCKED BY A CAM LEVER. ALL NECESSARY ADJUSTMENT FOR WEAR PROVIDED.

BUILT BY

SMITH & SAYRE MFG. CO.,

No. 245 Broadway, - - - New York City.

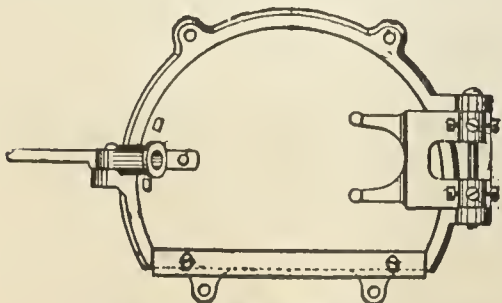

Brenner Self-Sealing Retort Door.

WILLIAM B. LUNDIE, Superintendent of the 42d Street Station of the Consolidated Gas Company, of New York, writes, under date of Jan. 4, 1889:

"We have 320 Brenner Self-Sealing Lids in use at this Station, built by the Smith & Sayre Mfg. Co. They require very little attention, and are the best of the kind that I have seen, giving entire satisfaction."

GAS WORKS APPARATUS AND CONSTRUCTION.

GAS WORKS APPARATUS AND CONSTRUCTION.

JAMES R. FLOYD & SONS,

(SUCCESSORS TO HERRING & FLOYD)

Oregon Iron Works,

W. 20th & 21st Sts., bet. 10th & 11th Avs.,

NEW YORK CITY.

Engineers and Contractors

FOR THE

CONSTRUCTION OF GAS WORKS.

MANUFACTURERS OF

All Kinds of Castings and General Ironwork

FOR

GAS APPARATUS.

Bench Castings, Regenerative and Half Regenerative Furnace Castings.

Condensers, Scrubbers, Purifiers, Street Drips and Connections,

Valves,

Hydraulic Hoisting Purifier Carriage, Self-Sealing Retort Lids, Improved

Valve Stand and Indicator, Seller's Cement.

Plans, Specifications, and Estimates furnished for Construction of New or Alteration of Old Works.

CONTINENTAL IRON WORKS.

THOS. F. ROWLAND, Prest.

WARREN E. HILL and CHAS. H. CORBETT, V-Prests.

THOS. F. ROWLAND, JR., Sec. & Tr

P. O. Station G., BROOKLYN, N. Y.

ENGINEERS AND MANUFACTURERS OF

Gas Holders

CONDENSERS, SCRUBBERS, VALVES,

PURIFIERS, SELF-SEALING RETORT LIDS'

Hydraulic Mains,

And all other articles connected with the manufacture and distribution of Gas.

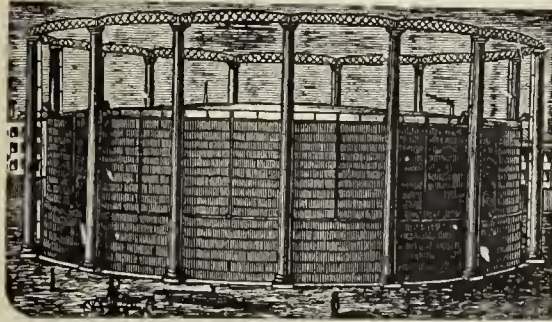

H. RANSHAW, Prest. & Mangr.

WM. STACEY, Vice-Prest.

T. H. BIRCH, Asst. Mangr.

R. J. TARVIN, Sec. & Treas.

STACEY MFG. CO.,

MANUFACTURERS OF

Single and Telescopic Gasholders,

IRON ROOFS, BRIDGES, LAMP POSTS,

Water and Oil Tanks, Coal Elevator Cars,

COKE CRUSHERS, BENCH CASTINGS,

And all kinds of Wrought and Cast Iron Work used in the erection of Coal and Oil Gas Works Rolling Mill Machinery and Heavy Castings a Specialty.

Foundry:

33, 35, 37 & 39 Mill Street.

Wrought Iron Works:

16, 18, 20, 22, 24 & 26 Ramsey Street:

Cincinnati, Ohio.

Bouton Foundry Co.,

FOUNDERS AND MACHINISTS,

CHICAGO, ILL.

Gas Works Apparatus,

PURIFIERS, CONDENSERS,

Bench Work

SPECIALS, LAMP POSTS,

SCRUBBERS,

Iron Roofs and Floors.

Plans and Estimates furnished for new works or extensions of old works.

1842. **DEILY & FOWLER,** 1890.

Laurel Iron Works.

Address, No. 39 Laurel Street, Philadelphia, Pa.

BUILDERS OF

GASHOLDERS,

Single and Telescopic.

HOLDERS BUILT 1884 to 1888, Inclusive:

Newport, R. I.	Long Island City, N. Y.	Port Chester, N. Y.	Malden, Mass.	West Chester, Pa. (2d)
Portland, Oregon.	Macon, Ga.	New Rochelle, N. Y.	Paducah, Ky.	Lancaster, Pa. (3d)
Allegheny, Pa. (2d.)	York, Pa.	Salem, N. J. (3d)	Norwich, Conn.	Facony, Pa. (two)
Atlanta, Ga. (2d.)	Chester, Pa.	Omaha, Neb. (2d)	Seattle, W. T.	Mount Vernon, N. Y.
N.Y. City (Central Gas Co)	Hazleton, Pa. (2d.)	Lynn, Mass. (2d)	San Diego, Cal.	Binghamton, N. Y.
Lynchburg, Va. (2d.)	Staten Island, N. Y.	Little Rock, Ark.	Northern Gas Lt. Co., of	Concord, N. H.
Saylesville, R. I.	Saugerties, N. Y.	Irvington, N. Y.	New York, N. Y.	Dover, Del. (2d)
Rondout, N. Y.	Clinton, Mass. (Lan. Mills)	South Boston, Mass.	Westerly, R. I.	Calais, Me.
Atlantic City, N. J.	Chattanooga, Tenn.	Rye, N. Y. (2)	Willimantic, Conn	New London, Conn. (2d)
Augusta, Ga.	Galveston, Texas. (3d.)	Woodstock, Ont.	Montclair, N. J.	West Chester, N. Y.
Waltham, Mass. (2)	Omaha, Neb.	Malden, Mass.	Attleboro, Mass.	Bay Shore, L. I.
Mahanoy City, Pa.	Fort Plain, N. Y.	Staten Island, N. Y. (2d)	Santa Cruz, Cal.	Washington, D. C.
New Castle, Pa.	Brunswick, Ga.	Woodstock, Ont.	Erie, Pa. (2d)	

WM. HENRY WHITE,

No. 32 Pine Street, - - - New York City.

ENGINEER AND CONTRACTOR FOR THE

ERECTION AND EXTENSION OF

GAS, WATER, AND ELECTRIC LIGHT WORKS,

Correspondence with Gas Companies contemplating extending or improving their Plants respectfully invited Plans and Estimates Furnished.

GAS COALS.

CANNEL COALS.

GAS ENRICHERS.

JAMES D. PERKINS. **PERKINS & CO.,** F. SEAVERNES.
 228 & 229 Produce Exchange, New York.
 Cable Address, "PERKINS, NEW YORK." Post Office Box 3695, New York.

GENERAL SALES AGENTS FOR

The Youghioghenny River Coal Company's

OCEAN MINE YOUGHIOGHENY GAS COAL.

HON. W. L. SCOTT, Prest. M. H. TAYLOR, Vice-Prest.

This Colliery is located at SCOTT HAVEN, PA., in the center of the Youghioghenny Gas Coal District, and produces the ONLY RELIABLE YOUGHIOGHENY COAL for gas purposes. (See Map on p. 87 of this JOURNAL, Feb. 16, '85.)

POINTS OF SHIPMENT,

Locust Point, BALTIMORE. Pier No. 62, PHILADELPHIA.

Also, SOLE AGENTS for the

BRECKENRIDGE CANNEL,

OF KENTUCKY.

Within the past two years we have delivered this Cannel to over ONE HUNDRED COMPANIES IN THIRTY-THREE DIFFERENT STATES, and it is now in use in some of the large Gas Works

On the Continent and in South America,

where it successfully competes with the Australian Shale. It is the ONLY AMERICAN GAS CANNEL of sufficiently high grade to warrant EXPORTATION TO EUROPE AND SOUTH AMERICA, and it is the only economical substitute for OIL OR NAPHTHA. ONE GROSS TON will produce

10,000 Cubic Feet of 75 Candle Gas,	} equal to {	750,000 Candle Feet of Gas, and 26 Bushels of merchantable Coke weighing 900 Pounds
or 12,500 " " 60 " "		
or 15,000 " " 50 " "		

This is the ONLY GAS CANNEL that will produce a REALLY MERCHANTABLE COKE. It can be delivered in parcels of one carload or more to any point in the United States or Canada. Cargo shipments of any size required can be made from NEW YORK, PHILADELPHIA, BALTIMORE, or NEWPORT NEWS. Samples will be sent and particulars of price, etc., forwarded upon application to above address.

JAMES & WILLIAM WOOD,

Gas and Cannel Coal Contractors,

No. 40 St. Enoch Sq., Glasgow. No. 2 Talbot Court, London.

Proprietors of the BATHVILLE COLLIERIES (which produce the celebrated BOGHEAD CANNEL), Shields, Shieldmuir, Drumpeller, and other Collieries. This Firm offer

STANDARD CANNELS,

Unequaled as Gas Enrichers.

Also, WEST FAIRMONT GAS COAL, of W. Va.

Analyses, prices, and all further information furnished on application to

Agency for U. S., Room 70 Nos. 2 & 4 Stone St., N. Y. City.

The Standard Oil Company,

REFINERS OF

NAPHTHA AND GASOLINES.

ALSO MANUFACTURERS OF

A Special Grade of Naptha for Gas Companies

FOR ENRICHING COAL GAS.

Correspondence solicited.

No. 43 Euclid Avenue, Cleveland, Ohio.

To Gas Companies.

We make to order CAP BURNERS to burn any amount under a stated pressure. Send for samples.

Also, SERVICE CLEANERS, DRIP PUMPS, and STREET MAIN PROVING APPARATUS.

O. A. GEFROER,

248 N 8th Street, Phila., Pa.

COKE CRUSHERS.

GAS COALS.

GAS COALS.

Newburgh Orrel Coal and Coke Co.

MINERS AND SHIPPERS OF

STEAM, SMITHING, AND GAS COALS,
Foundry and Crushed Coke.

Home Office, 33 S. Gay Street, Baltimore, Md.

J. HARRY LEE, President.

Shipping Wharves, Locust Point, Baltimore.

The Despard Gas Coal Co.,

MINERS AND SHIPPERS OF

DESPARD GAS COAL,

AND MANUFACTURERS OF

COKE.

MINES, Clarksburg, Harrison Co., W. Va.

WHARVES, Locust Point, Baltimore, Md.

OFFICE, 225 E. German St., " "

ROUSSEL & HICKS, } AGENTS. } BANGS & HORTON,
71 Broadway, N. Y. } 60 Congress St., Boston.

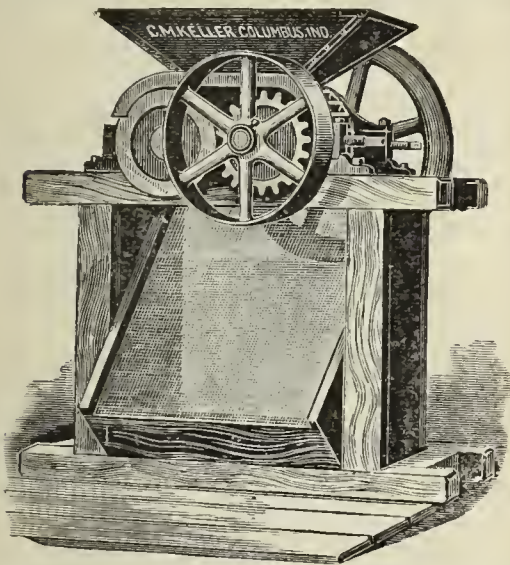

Keller's Adjustable Coke Crusher.

SIMPLE, STRONG, AND DURABLE.

C. M. Keller, Sec. & Supt. Gas Lt. & Coke Co. Columbus, Ind.

Correspondence Solicited.

King's Treatise on Coal Gas.

The most complete work on Coal Gas ever published

Three Vols. Bound, \$30.

BOOKS.

DISTILLATION OF COAL TAR AND
AMMONIACAL LIQUOR.

By GEORGE LUNGE. Price \$12.50.

A TREATISE ON THE COMPARATIVE
COMMERCIAL VALUES OF GAS
COALS AND CANNELS.

By DAVID A. GRAHAM. 8vo., Cloth. Price \$3.

Orders for these books may be sent to this office.

A. M. CALLENDER & CO.,

42 PINE ST., N. Y. CITY

**THE
PENN GAS COAL CO.**

OFFER THEIR

Coal, Carefully Screened & Prepared for Gas Purposes.

Their Property is located in the Youghiogheny Coal Basin, near Irwin and Penn Stations on the Pennsylvania Railroad, and on the Youghiogheny River.

Principal Office:

209 SOUTH THIRD STREET, PHILA., PA.

Points of Shipment:

Pennsylvania Railroad Piers; Greenwich Wharves, Delaware River; Pier No. 1 (Lower Side), South Amboy, N. J.

Chesapeake & Ohio Railway Coal Agency,

FOR THE SALE OF THE

Superior Kanawha Gas Coals, Cannelton Cannel,
Also, SPLINT AND STEAM COALS,

From the Kanawha and New River Regions, on the line of the Chesapeake & Ohio R'way.

C. B. ORCUTT, General Agent, - - No. 1 Broadway (Room 217) New York City.

FRANCIS H. JACKSON, Prest. EDMUND H. MCCULLOUGH, V.-Prest. CHAS. F. GODSHALL, Treas. H. C. ADAMS, Sec.

THE WESTMORELAND COAL CO.

Chartered 1854.

Mines situated on the Pennsylvania and the Baltimore and Ohio Railroads, in Westmoreland County, Penn.

POINTS OF SHIPMENT:

PHILADELPHIA, BALTIMORE, SOUTH AMBOY, N. J.,
WATKINS (SENECA LAKE), N. Y.

Since the commencement of operations by this Company its well-known Coal has been largely used by the Gas Companies of New England and the Middle States, and its character is established as having no superior in gas-giving qualities, and in freedom from sulphur and other impurities.

Principal Office, 224 South 3d St., Phila., Pa.

**The American Gas Engineer
and Superintendent's Handbook.**

BY WILLIAM MOONEY.

Consisting of Rules, Reference Tables, and Original Matter
Pertaining to the Manufacture, Manipulation, and
Distribution of Illuminating Gas.

350 Pages, Full Gilt Morocco.

\$3.00.

A. M. CALLENDER & CO., 42 Pine St., N. Y.

JOHN J. GRIFFIN & CO.,

Nos. 1513, 1515, 1517 & 1519 Race Street, PHILADELPHIA.
52 Dey St., NEW YORK. 75 N. Clinton St., (FRED. R. PERSONS, Mangr.) CHICAGO.

MANUFACTURERS OF

METERS FOR MEASURING GAS

IN ANY VOLUME.

Provers, Gauges, Registers, Etc., Etc

EXPERIMENTAL APPARATUS FOR QUANTITATIVE AND QUALITATIVE ANALYSIS.

Careful and Prompt Attention paid to Repairing of all kinds of Meters and Apparatus.

Estimates Cheerfully Furnished.



NATHANIEL TUFTS,

No. 153 Franklin Street, Boston, Mass.,

MANUFACTURER OF

DRY GAS METERS.

Station Meters of any Capacity.

Test and Experimental Meters, Pressure Registers, Pressure Gauges,
Pressure and Vacuum Gauges.

METER PROVERS, PHOTOMETERS, STREET LANTERNS, ETC., ETC.

Patent Cluster Lanterns for Street Illumination.

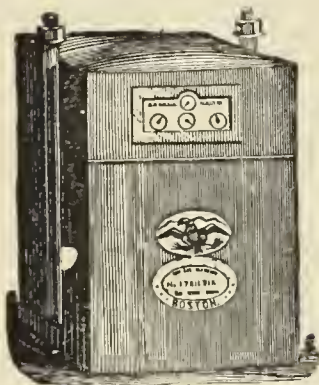

Dry Gas Meters.

With 40 years' experience and the best facilities for manufacturing, is enabled to furnish reliable work and answer orders promptly.

HAROLD J. BELL.

BELL & JONES,

S. LEWIS JONES.

No. 12 North Ninth Street, Philadelphia, Pa. Works at Royersford, Pa.

MANUFACTURERS OF

GAS METERS, STATION AND EXPERIMENTAL METERS,

Meter Provers, Pressure Gauges, and All Other Gas Appliances in Our Line.

WE REPAIR ALL KINDS AND MAKES OF METERS, AND THE WORK GUARANTEED.

High Pressure Meters for Natural Gas, in Iron Cases, guaranteed to stand 300 lbs. Pressure.

Gas Cooking and Heating Stoves, Hot Plates, Cake Griddles, Waffle Bakers, Boiling Stoves, Laundry and Tailors' Iron Heaters. Hotel and Cafe Ranges a Specialty.

Correspondence Solicited.

Estimates Furnished.

A. HARRIS.

E. L. HARRIS.

J. A. HARRIS.

Established 1849.

HARRIS BROS. & CO.,

Twelfth and Brown Streets, Philadelphia.

Manufacturers of Wet and Dry Gas Meters,

STATION METERS, METER PROVERS,

EXPERIMENTAL METERS, SHOW OR GLAZED METERS,

Pressure and Vacuum Registers, Gauges, Photometers, Drip and Bell Pumps, Etc., Etc.

PROMPT ATTENTION GIVEN TO ALL ORDERS. METERS THOROUGHLY REPAIRED. ESTIMATES FURNISHED FOR STATION METERS OF ALL SIZES. CORRESPONDENCE SOLICITED.

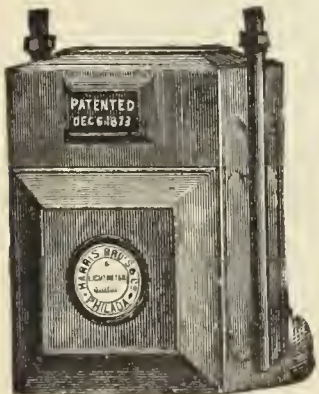

GAS METERS.

GAS METERS.

GAS METERS.

GEO. J. MCGOURKEY, Prest.

WM. H. MCFADDEN, Vice-Prest. (Phila.)

WM. N. MILSTED, Gen. Supt. and Treas. (New York).

WM. H. DOWN, Sec.

THE AMERICAN METER CO.

Established 1834.

Incorporated 1863.

WET AND DRY GAS METERS.

PRESSURE REGISTERS.

METER PROVERS.

STATION METERS.

PRESSURE & VACUUM REGISTERS.

PORTABLE TEST METERS.

EXHAUSTER GOVERNORS.

PRESSURE & VACUUM GAUGES.

EXPERIMENTAL METERS.

DRY CENTER VALVES.

CRESSON GAS REGULATORS.

AMMONIA TEST METERS.

GOVERNORS FOR GAS WORKS.

MARSLAND WATER METERS.

BAR & JET PHOTOMETERS.

Manufactories:

512 West 22d St., N. Y.

Arch & 22d Sts., Phila.

GAS STOVES.

SUGG'S "STANDARD" ARGAND BURNERS,

SUGG'S ILLUMINATING POWER METER,

Wet Meters, with Lizar's "Invariable Measuring" Drum.

Agencies:

177 Elm Street, Cincinnati.

211 & 216 N. Wells Street, Chicago.

810 North Second Street, St. Louis.

222 Sutter Street, San Francisco.

HELME & McILHENNY,

(Established 1848.)

CAS METER MANUFACTURERS,

Nos. 1339 to 1349 Cherry Street, Philadelphia, Pa.,

WET AND DRY GAS METERS. STATION METERS, EXPERIMENTAL METERS, METER PROVERS,

Center Seals, Pressure Registers, Governors, Indicators, Photometers, and all other kinds of Apparatus for use in Gas Works.

FOULIS' PATENT STATION AND DISTRICT GOVERNORS.

REPAIRING DEPARTMENT.—We employ a special force of skilled workmen repairing meters of all makers.

WM. WALLACE GOODWIN, President and Treasurer.

E. STEIN, Vice-President.

H. B. GOODWIN, Secretary and Superintendent.

THE GOODWIN GAS STOVE AND METER CO.,

Successors to W. W. GOODWIN & CO.

1012, 1014 and 1016 Filbert St., Phila., Pa.

142 Chambers St., New York City.

76 Dearborn, St., Chicago, Ills.

WALDO BROTHERS, Agents, 88 Water Streets, Boston, Mass.

MANUFACTURERS OF

DRY AND WET GAS METERS,

Station Meters (square, cylindrical, or in staves), Glazed Meters, King's and Sugg's Experimental Meters, Lamp Post Meters, etc., etc. Meter Provers (sizes 2, 5, and 10 feet), Pressure Gauges of all kinds, Pressure Registers, Pressure and Vacuum Registers, Pressure Indicators (sizes 4, 6, and 9 inch), King's Pressure and Vacuum Gauges, Dry and Wet Center Seals, Dry and Wet Governors, Exhauster Governors, Photometers of all descriptions. Letheby's Sulphur and Ammonia Test Apparatus complete. Also, Testing and Chemical Apparatus of all kinds, and of the most perfect description, for all purposes relating to Gas.

Manufacturers of the "SUN DIAL" GAS STOVES, for Cooking and Heating.

Goodwin's Improved Lowe's Jet Photometer.

Agents for Bray's Patent Gas Burners and Lanterns.

Special attention to Repairs of Meters and all Apparatus connected with the business. All work guaranteed first-class in every particular. Orders filled promptly.

G. B. EDWARDS, Manager, New York.

S. S. STRATTON, Manager, Chicago.

D. McDONALD & CO.,

GAS METER MANUFACTURERS.

(Established 1854.)

51 Lancaster St., Albany, N. Y.

34 & 36 West Monroe St., Chicago, Ill.

STATION METERS, EXPERIMENTAL METERS, METER PROVERS, PRESSURE & VACUUM REGISTERS, PRESSURE GAUGES, ETC.

Also STAR GAS STOVES, RANGES, and HEATING STOVES.

We use only the very best materials, and employ the most skilled labor, and by our long experience (36 years) and personal supervision of every detail, we feel justified in assuring the public that our goods will give perfect satisfaction. Every Meter emanating from our establishment will bear the State Inspector's BADGE, and will be fully warranted by us. Our Annual and Calendar will be sent to Gas Companies upon application.

WM. WALLACE GOODWIN, President. E. STEIN, Vice-President. H. B. GOODWIN, Sec. & Supt. G. B. EDWARDS, Mang'r, New York. S. S. STRATTON, Mang'r, Chicago.

THE GOODWIN GAS STOVE AND METER CO.,

1012-18 Filbert St., Phila., 142 Chambers St., N. Y., 76 Dearborn St., Chicago.

Agents, WALDO BROTHERS, 88 Water Street, Boston.

SOLE MANUFACTURERS OF THE

"SUN DIAL" GAS STOVES,

The Most Economical, Efficient, and Durable Gas Stove Made.

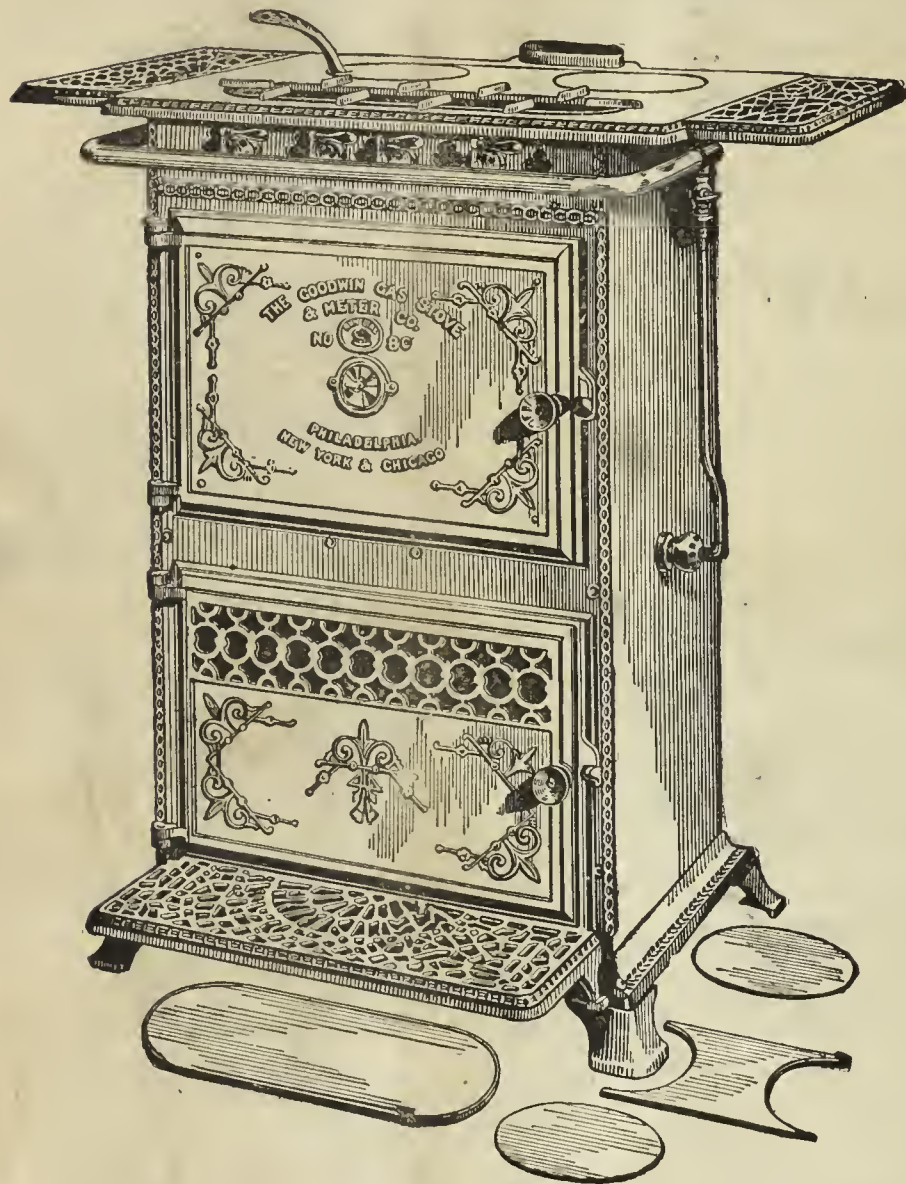

GAS COOKING STOVE, No. 8 C.

SIZE.

Stove.	Oven.	Roaster.	Top.	Length over Extension Shelves,
37 in. high. 20 in. wide.	12 in. high. 17½ in. wide. 12 in. deep.	12 in. high. 18 in. wide. 13 in. deep.	24 in. long. 21 in. wide.	36 in.

This stove has four burners on top, and double oven burner. Consumption of gas with all burners in use, 12 feet per hour, at 1 inch pressure. The top is made in sections, so that a greater variety of cooking utensils may be used. By lifting out the covers and crosspieces and putting in a suitable forked ring, which is sent with each stove, a wash boiler or other large utensil may be set over two burners. Our No. 87 GRIDDLE also fits in the same position. The roasting oven is provided with a cast-iron door.

All Fittings are Nickel-Plated.



GAS COOKING STOVE, No. 7 B.

SIZE.

Stove.	Oven.	Roaster.	Top.	Length over Extension Shelves,
31 in. high. 17 in. wide.	9½ in. high. 14½ in. wide. 12 in. deep.	10 in. high. 15 in. wide. 13 in. deep.	21 in. long. 16 in. wide.	32 in.

This Stove has three boiling burners in the Top or Hot Plate, and one single oven burner.

This cut represents our New Style Cooking Stove. As will be seen, it has an ornamented cast-iron Base and Front, and extension shelves. The Oven Burner, which is atmospheric (unless otherwise ordered), is of an entirely new and improved pattern (patent). The ovens are of greater capacity than those of the old style. The Top, in conjunction with the Outlet Pipe, is designed to carry off all the products of combustion, if desired, but they are also supplied with a loose ring which converts it into an ordinary open top stove.

The consumption of this Stove is 35 cubic feet per hour at 1 inch pressure, with all Burners in use.

All Fittings are Nickel-Plated.

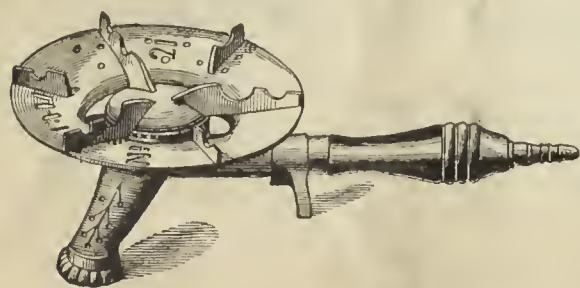

"RADIANT" BOILING STOVE, WITH REGENERATIVE BURNER.

Size, 6½ inches diameter, 8 inches high. Consumption, 6 feet per hour at 1 in. pressure.

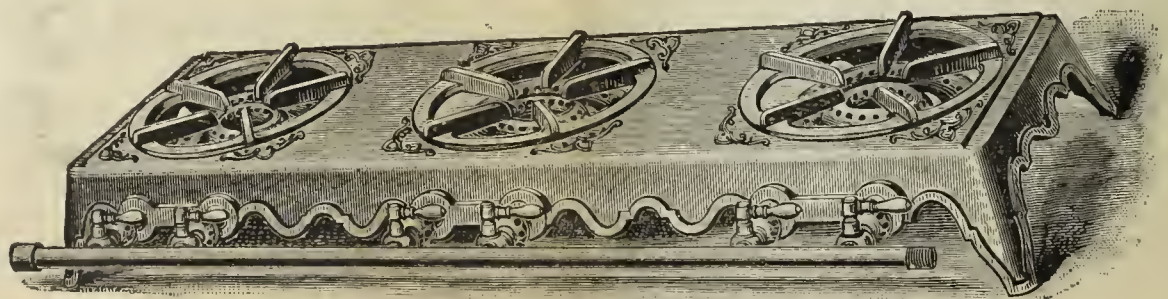

HOT PLATE, No. 111.

Size, 36 in. long, 12 in. wide, with three double burners, 6 taps. Consumption, with all burners in use, 36 cubic feet per hour, with 1 in. pressure. ½ in. supply pipe should be used where the pressure is 1 in. or over.

THE AMERICAN

GAS LIGHT JOURNAL

REDMAN & KENNY, N. Y.

PUBLISHING OFFICE NO. 42 PINE STREET

DEVOTED TO THE INTERESTS OF ILLUMINATION, VENTILATION, WATER SUPPLY AND DISTRIBUTION, & GENERAL SCIENCE.

VOLUME LII.—No. 20.
Whole No. 780.

NEW YORK, MONDAY, MAY 19, 1890.

{ \$3 PER ANNUM,
IN ADVANCE.

A. M. CALLENDER & CO., Proprietors. C. E. SANDERSON, Manager.
JOS. R. THOMAS, C.E., Editor. T. J. CUNNINGHAM, Asst. Editor.

ENTERED AT THE POST OFFICE AT NEW YORK, N. Y.
AS SECOND CLASS MATTER.

Published on each Monday of the year, at No. 42 Pine Street, N. Y.

Terms of Subscription, Including Postage.—For the United States and Canada, \$3 per annum. European countries, \$4.50 (19 shillings—22½ francs). All payments to be made in advance. Single copies, 10 cents.

Remittances should be made either by post-office order, registered letter, or bank draft on New York, payable to the order of A. M. Callender & Co.

Collections are invariably made directly from this office, for subscriptions, advertisements, etc. We have agents to solicit the same, but they are not authorized to receipt for money.

Correspondence.—Wishing to make this JOURNAL a gazette of intelligent discussion to those of our readers who may wish to gain or give information on the subjects to which its columns are devoted, correspondence is solicited for publication from all who make the study of those subjects a pleasure or a profession.

The American News Company, Nos. 39 and 41 Chambers street, New York, are agents for this JOURNAL. Newsdealers will send orders to them.

Books.—We will forward by express, at publisher's lowest rates, any book—scientific or otherwise—to any address in the United States or Canada. No book will be sent C. O. D.

CONTENTS.

An Asterisk (*) denotes an illustrated article.

OFFICIAL NOTICE—

Western Gas Association..... 693

EDITORIALS—

Briefly Told..... 694

The Day is at Hand—The Gas Statistics Branch of the Eleventh Census—Notes.

The Market for Gas Securities..... 694

Did Dr. Wilkinson Confine Himself to Facts? by Mr. Jas. Somerville..... 695

An Odd Experience in a Purifying Room, by Mr. Irvin Butterworth 695

Notes upon Distributory Plant, by Mr. W. J. Warner..... 695

Gas Engines with Electrical Ignition..... 697

*Dye's Apparatus for Washing Gas..... 698

Progress of the Electric Light in Australia..... 699

The Identity of Light and Electric Radiation..... 700

Spontaneous Combustion of Coal in Ships..... 700

ITEMS OF INTEREST FROM VARIOUS LOCALITIES..... 702

Improvements at Rome, N. Y.—Annual Meeting, South Side Company, Plattsburgh, Pa.—Glass Mains for Vapors and Liquids—Opposition at Burlington, Ia.—All Right at Ironton, O.—Annual Meeting, Perth Amboy, N. J.—Personal—Annual Meeting, Metropolitan Company, Elizabeth, N. J.—Capital Stock Increased—Annual Meeting, Altoona, Pa.—Cheaper Gas for Syracuse, N. Y.—Strike at Peoples Works, Manchester, N. H.—Death of Chas. Monson—Annual Meeting, Bangor, Me.—An Accident—Tinkering the Meter Inspection Laws, Canada—Improvements at North Adams, Mass.—More about the Strike at Manchester, N. H.—Manager McMillan's Plan at La Crosse, Wis.—Gas Company for Summit, N. J.—And Many Other Items.

Ingenious Expedient in Hydraulic Engineering..... 705

Useful Memoranda and Information for Engineers..... 705

CORRESPONDENCE—

Gas Companies Should Control the Introduction of Gas Stoves... 705

[OFFICIAL NOTICE.]

Western Gas Association.

SECRETARY'S OFFICE, WESTERN GAS ASSOCIATION, }
QUINCY, ILLS., May 14, 1890. }

The Thirteenth Annual Meeting of the Western Gas Association will be held at the Lindell Hotel, St. Louis, Mo., on the 21st, 22d and 23d days of May. The hall in which the business sessions of the Association will be conducted is within the hotel building, is very commodious, quiet, and in every way excellently well adapted to our requirements. The hotel management has granted on this occasion the following rates: For single room and board, \$2.75 per day; for room with bath, \$3.25 per day. These rates will apply to members in attendance, their families and visiting brethren. In this connection I am instructed by the Local Committee of Arrangements to give our members warning of the fact that in order to secure suitable accommodations, their rooms *must be engaged in advance*. Your Secretary has been in the habit of making an announcement to this effect with exceeding regularity from year to year, and just as regularly no one, or at least only very few, pays the slightest attention to the warning. The necessity of engaging quarters in advance, however, is in this instance very urgent. Now that the old Planters' House has been closed, the Southern and Lindell Hotels often have more business thrust upon them than they are capable of handling, and of late it has been no unusual occurrence for them to deny would-be guests admission, unless their rooms had been previously spoken for. But all of our members can be accommodated without the slightest jar or friction, if they will but take the trouble to address a line to the "Proprietor of the Lindell Hotel, St. Louis, Mo.," telling him the kind and price of room or rooms desired. This should be done at least one week in advance of the first day of the meeting.

In addition to the reduction in transportation rates granted by the Central Traffic Association, the Trunk Line Association has also joined in the movement. As the boundary of the latter Association extends as far east as the western border of the New England States, our Eastern friends will be enabled to avail themselves of the reduced fares.

I am authorized to state that Mr. R. D. Walsh, Chairman of the Local Committee of Arrangements, has kindly consented to take charge of all articles destined for the Gas Exhibit, and will cheerfully surrender a generous portion of his time to the interests of exhibitors. Communications, consignments of gas stoves, apparatus, burners—anything, in fact, intended for the Exhibit—may be directed to Mr. Walsh, in care of the Laclede Gas Light and Coke Company. Exhibitors can rest assured that not only will their wares receive careful handling and be displayed to the best possible advantage, but that they themselves will be accorded the most courteous treatment at the hands of Mr. Walsh and his efficient committee.

The "Paper List" for our Thirteenth Annual will be as follows:

"Relative Value of Gaseous Fuels," by B. E. Chollar.

"Effects of Natural Gas Competition," by James Somerville.

"An Argument in Favor of the Adoption of a Uniform System of Estimating the Cost of Gas in the Holder," by George G. Ramsdell.

"Impressions of British Gas Works," by George T. Thompson.

"Mixed Gases," by E. G. Cowdery.

"Wrought Iron, Cast Iron, or Steel—which is the Best Material for Street Mains?" by Eugene Printz.

"What Policy Should the Gas Interest Adopt in Connection with the Approaching World's Fair?" by Walton Clark.

"On the Abuse of the Patent System as Bearing on the Gas Industry, with a Remedy," by Frederic Egner.

"The By-Products of Experience," by Allen R. Foote.

The attention of the Board of Directors is called to the fact that Section I., of Article VII., of our By-Laws reads as follows: "The Board of Directors shall meet as such at least once in each year, on the day preceding the annual meeting of the Association, at which time they shall determine in regard to the propriety of the various papers, drawings, models, or other matters constituting the special order, being laid before the Association." The Board of Directors elected at our last meeting is composed of the following-named gentlemen, who are, therefore, particularly requested to assemble at the Association's headquarters on Tuesday morning, May 20, at 10 o'clock:

J. B. Howard, E. H. Jenkins, Z. T. F. Runner, John Gimper, C. W. Butterworth, E. G. Cowdery, J. S. Ambrose, J. W. Dunbar, and B. E. Chollar.

The social features of the Thirteenth Annual, as provided by the Entertainment Committee, will be as follows:

On Thursday evening there will be a grand moonlight excursion and supper on the Mississippi, the handsome steamer *Oliver Bierne* having been engaged for the occasion. A trip will be made up the river as far as the Chain of Rocks, giving a view of the new water works now in process of construction, and also of the recently completed Merchants' Bridge. On returning, the steamer will run down below Carondelet, affording a beautiful twilight view of the full 16 miles of the city's front along the Mississippi. Supper will be served, and there will also be music and dancing, the boat returning to the wharf at 10 o'clock.

On Friday, at 10:30 A.M., carriages will be in readiness at the hotel for delegates and their guests. A drive will be taken through the western portion of the city as far as the Fair Grounds, where a luncheon will be served at the Jockey Club House. After a series of entertainments, beginning at 2 o'clock P.M., which have been generously tendered by the Board of Directors of the Fair Grounds, parties wishing to take a drive through the parks may do so at their pleasure, in carriages provided by the committee.

Ladies accompanying delegates can obtain carriages at any time during Wednesday and Thursday for such purposes as they may desire.

From the above it will be seen that the time-honored custom of serving a banquet on the second night of our reunion will be departed from. This is an innovation which the committee feels assured will receive a hearty welcome from the "Toast-Responders," and possibly from many others for the mere sake of a change, if for no other reason.

Application blanks, copies of our By-Laws, and any information not contained in these communications will be cheerfully furnished by

A. W. LITTLETON, Sec'y.

(Since writing the foregoing, your Secretary has received word that the lines operated by the Southern Passenger Association will grant the same rates as those which will be given by the Central Traffic and Trunk Line Associations, viz., one fare and one-third for the round trip. These fares can be obtained on the certificate plan. Any railroad ticket agent within the territories of these three passenger associations will take pleasure in informing a member as to the steps that are required for securing these reduced fares. It is hoped that every delegate who can do so will avail himself of the reduction.)

BRIEFLY TOLD.

THE DAY IS AT HAND.—Before this number of the JOURNAL shall have been completely distributed the Thirteenth Annual of the Western will be over and its record a part of history. Look at it as we may, at the time of writing, however, we are in the full knowledge that the session is to be a memorable one. Every arrangement for the mental and social side of the occasion has been made, and made with thoroughness and cleverness. The Eastern delegation will be on hand in greater numbers than ever before, and they go in the certainty that a royally fraternal time is to be their portion.

THE GAS STATISTICS BRANCH OF THE ELEVENTH CENSUS.—The following, from Superintendent of the Census explains itself. We hope that the proprietors of gas works will see to it that the returns respecting the gas industry are as full and complete as it will be possible to have them. The compilation cannot fail to benefit all, and that benefit will

be in exact proportion to the completeness of the figures submitted. Supt. Porter's letter is as follows:

"DEPARTMENT OF THE INTERIOR, CENSUS OFFICE, }
WASHINGTON, D. C., May 14, 1890. }

Census of Manufactures.—On the 2d day of June the work of collecting statistics of manufactures for the report of the Eleventh Census will be inaugurated throughout the entire country. The value of this report must depend wholly upon the accuracy and thoroughness with which manufacturers answer the questions propounded. The personal interests of every manufacturer are involved in the character of the report on Manufactures. It will be quoted for the next ten years as the official announcement of the *exact* industrial condition of the country, and will be the basis for any future legislation that may be enacted in regard to the wants of our people, whether engaged in agricultural or mechanical pursuits. Therefore it is of vital importance to each manufacturer that an accurate report shall be made. The Superintendent of census has taken every possible precaution in the preliminary work to make this census complete and satisfactory, and the earnest co-operation of those engaged in productive industry is all that is now necessary to secure valuable results. Every manufacturer should bear in mind that his answers to the questions relating to his business are held strictly confidential, are not disclosed to any competitor or to other persons, and are not used by the Government as predicate for the purposes of taxation or license, or in any way adversely to affect his individual business. This assurance is printed on each schedule over the signature of the Superintendent of Census. The expert Special Agent in charge of this branch of census work, Mr. Frank R. Williams, has personally visited the principal manufacturing centers and consulted representative manufacturers, the publishers of trade journals, and practical business men generally, for the purpose of ascertaining the proper scope of the inquiry for each branch of manufacture. The questions contained in the census schedules are those suggested by the manufacturers and other persons most interested in the progress of the country, and cover ground absolutely essential to the proper presentation of its industrial conditions and resources.—ROBT. P. PORTER, Supt. of Census."

NOTES.—In a letter to the publishers, dated Alton, Ills., May 12, Secretary Tracy, of the Alton Gas and Electric Light Company, writes: "Alton at this time is experiencing quite a boom. We are building a \$30,000 opera house, an I. O. O. F. temple, and a public library. In fact you can hardly visit any part of the city without witnessing some evidence of growth in the shape of new residence buildings, etc. With all this bright outlook the Gas Company shares its part. I will lay about one-half mile of 3-inch main as soon as I can get the pipe. I will also put in a hot tar scrubber and substitute iron sponge for lime. A comparison of April 1889 and 1890 shows an increase in gas sales to private consumers of 29 per cent., and from appearances at this time, next April will show an increase of at least 50 per cent. over the April just closed." The light of the present seems to hold its own.—At the annual meeting of the Easton (Pa.) Gas Company the following Directors were elected to serve for 3 years: Samuel Boileau, Robt. I. Jone and Wm. A. Seitz. At the Directors' meeting the following officers were elected: President, S. Boileau; Treasurer, Edward Hilliard; Secretary, W. G. Stewart; Supt., W. H. Ward.—The furnaces of the Pennsylvania Tube Works, Pittsburgh, will be remodeled to burn producer instead of natural gas. The cost involved in fitting the works for the change will not be less than \$120,000.—A gas company for Norwich, N. Y., has been incorporated by Messrs. Dudley Farlin, J. White Sprong and E. F. Murray. It is capitalized in \$50,000.—Mr. Lucius D. Rhodes, Superintendent of the Holyoke (Mass.) Water Power Company's gas works, died at his home in that city on the 7th inst. He came to Holyoke in 1863, from the works of the Hartford (Conn.) Gas Company, and his record in the former place speaks for itself. He was in his 61st year.

The Market for Gas Securities.

The upward movement in Consolidated gas continued through the week, and the stock is bid for to-day (Friday) at 105 $\frac{1}{4}$. We would advise caution now in the matter of its purchase; that is, in respect to purchase on speculative account. For investment purposes it is worth at least 110. Mutual gas is very strong, the bid figure being 115 with no shares offering. Brooklyn stocks are steady. The event of the week, perhaps, was the rise in Chicago Trusts, which sold up to 67 $\frac{1}{2}$. To-day the stock is bid for at 63 $\frac{1}{4}$. We would not advise purchase at anything above 60, for the present at least. Bay State is up to 84, and will soon be in the dividend list. Laclède common is up to 27 $\frac{1}{4}$, and the preferred, at 64 to 70, looks to be a purchase.

Did Dr. Wilkinson Confine Himself to Facts?

By MR. JAMES SOMERVILLE.

Dr. Wilkinson, in his lecture on "Some Facts Connected with the Manufacture of Water Gas," as published in your issue of April 28th, makes a statement regarding coal gas which appears to me, coming from such a source, ought not to remain any longer uncontradicted. In speaking of the purity of water gas, he says, "Compare this with coal gas, where we have from 20 to 40 grains of sulphur, and from 5 to 7 grains of ammonia to the 100 feet."

If he had said seven-tenths of a grain of ammonia, and from 8 to 10 grains of sulphur per 100 feet, he would have been much nearer the truth. Ammonia is too valuable a product to allow any of it to be retained in the gas. There is no sulphureted hydrogen, and the amounts of sulphur compounds that may escape the action of the lime and oxide are so small that the resultant sulphurous and sulphuric acid from the combustion of the gas is practically harmless to health.

The bleaching of the goods to which he refers is not due to the impurity of the gas, but to the stratum of highly heated air to which they are constantly exposed. The same result has been observed in houses in which gas was never used. As for those poor people whom he so pathetically describes as dying of slow poison, this distressing condition is not due to impure gas, but to the want of oxygen or fresh air, and it seems to me it would have been more in keeping with his profession if, instead of decrying the use of gas, he had insisted upon a proper system of ventilation.

Our friends, the enemy, are not slow to pick up such statements and use them to the disadvantage of our industry.

An Odd Experience in a Purifying Room.

By IRVIN BUTTERWORTH.

Last fall this Company (the Columbus, O., Gas Light and Coke Company) purchased a lot of new oxide, two car loads of the Connelly sponge and three of Prof. Douglas's ferric oxide, from Michigan. The material was put into use in the usual way, the two oxides soon becoming thoroughly mixed together until the material was homogeneous. We endeavored to revive the spent material by blowing air through it in the "off" boxes, by means of a rotary blower operated by a gas engine. The cover was not removed, and the air was blown into the inlet, passing up through the oxide in the same manner as the gas passes, and escaping through the small cap-hole in the cover.

This plan of revivification worked successfully for some time, and we did not have any trouble whatever from the heating of the oxide, though we had to empty and refill boxes occasionally, on account of back pressure caused by the caking of the material.

But the oxide soon began to apparently lose its efficiency, and after being revived in the above manner would soon pass the sulphureted hydrogen, necessitating two or three changes daily, and the almost constant running of the blower. Our material, we noticed, had begun to assume a dark, greenish appearance, and that which we would remove from the boxes and expose to the air would not go through the chemical heat of revivification, nor change its color from the dark green to the characteristic brown of properly revived oxide. In fact, it did not seem to reoxidize a particle. And yet, by frequently changing boxes and keeping our blower in operation almost night and day, we have been able to purify our gas.

I should mention, as having a possible bearing upon our ability to do this, that during about 16 or 18 hours out of every 24 we scrub our gas through hydraulic main liquor, of about 2 ounces strength; and we also constantly introduce into our gas at the exhauster about 1 per cent. of air.

About three weeks ago, as an experiment, we discontinued the running of the blower, and tried the effect of throwing the material out of the boxes and exposing it to the air in the old way, with the effect of increasing, slightly, the length of time that the boxes would run without changing, but not tending, to any perceptible degree, to bring the dark green material back to the proper color, nor promoting its revivification to any very noticeable extent.

An analysis of our purifying material (which has been lightened by the admixture of about one-third its bulk of sawdust) shows that it now contains over 10 per cent. of sulphates of iron. This, of course, accounts for its dark green color. Just how much iron it contains in other forms, and what the total percentage of sulphur is, we do not as yet know; but an analysis is about to be made to determine these points.

In the meantime, we are able to purify our gas by making two or three changes daily.

Three or four questions present themselves, viz.:

1st—As our material does not show any of the evidences of revivification on being removed from the boxes when foul, how, or by what agent, is our gas being purified?

2d—If it is sesquioxide of iron in our material that is performing this work, why does the material not show some of the usual evidences of revivification?

3d—Have any gas companies who revive their oxide by blowing air through it had any experience similar to ours?

4th—Has the blowing of air through our oxide been the cause of our trouble, and if so, how could this plan have a different effect in this respect from that of exposing the material to the air?

Notes upon Distributory Plant.

[Read by Mr. W. J. Warner, of South Shields, before the North of England Gas Managers' Association. Reprinted from the London Journal.]

I very much regret not having been in a position to comply with the request of your Committee to contribute on the present occasion a paper to this Association. Though not in possession of matter of sufficient importance for a paper, I had a few notes which I thought might interest you, and draw forth some expression of opinion, which, backed by observation and experience, might be of value at a time when an attempt is being made by the users of steam rollers to remove from themselves the responsibility attached to such use.

In a paper on the subsidence of gas mains, by Mr. Drewry, of Cleethorpes, read at the recent meeting of the Eastern Counties Association, the writer gives his experience with mains laid in loose soil subjected to tidal influences and disturbed by sewerage works—resulting in a considerable subsidence of the main and its ultimate fracture. Reference was made in the discussion of the paper to the general disturbance of gas mains by "the necessities of domestic civilization," so termed by Mr. C. E. Jones, of Chesterfield—viz., the "water-carriage system, sewers, the multiplicity of telegraph, telephone, and electric lighting poles, and electric lighting mains." It will be observed that reference here is only made to the disturbance of the ground from these operations—the actual doing of the work. Beyond these disturbances within, if they may be so termed—the cutting of the trenches, inadequate shoring, improper filling in, and the disturbance of the joints by such operations—there is the disturbance from without, or from the surface of the ground—the road making operations, the general traffic over the ground, and the passing of heavy loads over the surface of the road.

Having a record, extending over some years, of the defects found in mains and pipes other than those of an ordinary character, I have arranged them in a tabulated form. Though this scarcely covers the whole of the ground, yet it may be of some value as a contribution to the subject. These entries of the whole are divided into five divisions, with the number of breakages in each, and the percentages, the sizes of the smallest and largest pipes, and the mean diameters, as follows:

No.	Cause.	No. of Breakages.	Percentage of Whole.	Sizes of Pipes.		
				Max. Inch.	Min. Inch.	Mean. Inch.
1.	Bad castings	7	6.48	12	1½	3.79
2.	Drainage operations	51	47.22	6	¾	2.29
3.	Heavy weights passing over roads . . .	16	14.82	12	2	3.62
4.	Steam roller passing over roads	17	15.74	6	¾	2.40
5.	Unknown	17	15.74	8	1	3.00

Two of the latest reports are as follows: "March 11, 1890.—Jarrow district: Escape in a ¾-inch service; connecting piece drawn from main by pressure of steam roller; the pipe end quite bright; pipe bedded in soft clay." "April 2, 1890.—Shields district: Escape up lamp pillar; opened out the service, and found it extended from the end of the main; a connecting piece drawn from the socket; the end of pipe was as bright as silver; steam roller was there a few days prior to escape being reported; pipe laid in clay." I am told there have been other cases in these districts; but until that reported on March 11, when the pipe was taken out of the ground "quite bright," attention was not directed to the matter as the cases were only considered as ordinary disturbances of service pipes. But these cases of brightly burnished pipes attracted attention and were reported to me shortly after the other case was found. One of the pipes I have here on the table; the other, unfortunately, has been mislaid.

The general experience of an excessively heavy weight passing over mains and pipes is drawn joints and fractured pipes, caused through the pipes being laid in a yielding soil, or in one of varying densities, or over an unequal rocky surface. It is not, I believe, an uncommon opinion that the disturbance of the mains and pipes is confined to the direct downward pressure of the weight—that is to say, that a heavy casting, or traction engine, or a heavy steam roller passing over mains and pipes will affect only those immediately under the weight. But may there not be other disturbances from the same cause not so obvious, being further removed, but still directly traceable to this downward pressure? There must of necessity be a lateral disturbance of the subsoil. In a case under my own observation there were yards of guttering, curb, and concrete pavement forced up along a line parallel with the track of a steam roller about two yards away from the nearest edge of the roller; thus proving, if proof were necessary, in the clearest manner, that there are other disturbing movements than those of the direct downward pressure of the moving weight. The injury then may be more remote, and the cause of a more complex character than is generally assigned to such disturbing influences.

The ultimate effect may be a general and permanent settlement of the plant till a further disturbance of the ground takes place; but there may be (and it is to this that we should direct attention) such an elasticity in the ground and plant, or in the plant alone, that a prejudicial action may be maintained by the ordinary traffic over the road, and so affect the joints of the pipes. In other words, the compression of the ground in which the pipes are laid may not only cause an immediate disturbance of the joints and breakage of the pipes, but may throw such strains upon the plant that there may be a deteriorating action continued, accompanied by a constantly increasing quantity of gas unaccounted for—an increase which might baffle every attempt to discover the cause of the loss, but which may be accounted for by a general deterioration of plant from the vibratory action of a steam roller. If the pipe shown may be taken as a true indication of the otherwise unseen action upon the mains and pipes, the fractured pipes and the drawn joints of mains, though more dangerous, are of little consequence when compared with this action, as they will soon tell their own tale and get repaired. But the other necessitates a constant, careful watchfulness and expense, which, I may say in passing, is not dreamed of by the promoters of electric lighting. Whether such deterioration is going on, and whether it will be continuous, must be a matter of observation. Doubtless, with the repeated rolling of the ground it will become more consolidated, and therefore better able to resist undue action and excessive pressure when so consolidated. A general inspection, repairing, and testing of the plant may again reduce the unaccounted-for gas to a moderate percentage of the make.

Though, in the percentages given, the steam roller injuries are lower than the drainage operations, yet the roller may have helped to swell the latter. However, this fact stands plainly out—that nearly 70 per cent. of the injuries to the distributory plant of a gas undertaking arise from the operations of local authorities; and if there be a still further general deterioration it behoves such authorities to carry on their work with much greater watchfulness than has been sometimes done—to shore, and fill in their drainage trenches with more care; and to use the roller over the ground in the forming of new roads before the pipes are laid, thus avoiding any greater settlement than there must of necessity be. I would also suggest that, in the carriage of excessive heavy weights over the roads—such as a casting drawn by a team of 25 horses—there should be a previous notice given to the local authorities, and the route to be taken decided on and registered. Such a course is justified by the fact that about 16 per cent. of the injuries recorded were caused by this work; and we may fairly assume that a portion of the percentage of “unknown” was from the same cause.

Now what is the remedy—that to which I directed attention some years since, viz., districting and sub-districting a town, as far as it can practically be done, and isolating and testing the mains. Since my paper was read I believe much has been done in this direction. Papers have been read upon the subject abroad; and the latest patent is that of the combination syphon test-box for this purpose, by Mr. Lyon, of Colsham. In the meantime closer attention should be given to the syphons than I believe is generally done. They should be sounded at regular intervals, and the depth of water found entered in a book and compared. Thus the syphons may become indicators of the condition of the mains; and through them the leakage traced to its source. This will not, however, be equally serviceable in all soils. Then there is that beautiful, sensitive and serviceable machine—the governor, which may be made to do excellent service in this work if closely observed, as it will give a very good indication of an increased flow of gas into a district; and for

such work I believe that form which is manipulated by counterbalance weights is the best.

Discussion.

Mr. W. Ford (Stockton) said he was afraid that what little information he could contribute was almost all contained in the paper which Mr. Warner had so carefully prepared. Mr. Warner made no remark as to whether, since steam rollers had come into vogue, he had adopted the ordinary method of laying service pipes and mains deeper. Some years ago they had very great trouble with the steam roller in Stockton; and it necessitated considerable relaying of their pipes. Since then they had had very little trouble. Mr. Warner said that something more than downward pressure was to be attributed to the steam roller. It was natural that the surface might be a movable subject; but still the underground might be quite firm, and the service pipe or main would receive no damage from the steam roller. If ordinary care was exercised in the laying of mains a great amount of trouble and anxiety to gas companies and corporations would be avoided. He was, however, only stating his own experience of the last 14 or 15 years. In consequence of the precautions they had taken in the deepening of their mains and service pipes the leakage, which, before the era of the steam roller (some 16 to 21 years ago), was 24 per cent., had been reduced to an average of 5 per cent. for the last few years. So that he thought, with care, where steam rollers were in existence, gas managers might reduce the leakage, independently of the action of the local authorities.

Mr. Pettigrew, Gas Engineer to the North-Eastern Railway Company, said he found that his services were often pulled out but seldom drawn. The weight actually dragged them out, and broke the mains at the place where they were connected. He had found pipes, 6, 8, 12, 14 and 20 inches in diameter, drawn sufficiently for his hand to be passed between the two; but this was caused by subsidence of the soil. He had constantly to be cutting out and putting pieces into the mains, but not into the services. Their services were laid in pitch boxes, not deep; and they always discovered, where a weight went across a pipe, it was downward action that took place—the pipe was broken, but never drawn.

The President said he was sure they were very much obliged to Mr. Warner for his paper. Four or five years ago he had some experience of the action of the steam roller. Some time previously a new sewer had been laid in the street, below the gas and water mains; and evidently a subsidence took place below these, or rather on one side of them. When the roller was put to work there, it broke first the water and then the gas pipe. The water pipe was 3 inches in diameter, and the gas pipe 2 inches. The water carried the gas down into the sewer below. It was a street something like 500 yards in length, and the gas entered the cottages on one side of the street through the drains. They did not observe the escape in the street; and when they became aware of its existence they could not find it. They had to cut the street at both ends and isolate it, and follow the main until they found the leakage. This was caused by the subsidence of the subsoil, and the steam roller running over the top. The result might have been disastrous; but happily they discovered it before very serious consequences took place. He did not understand Mr. Warner to say that the service was drawn asunder, but that there was a motion, an actual draw, by the passage of the roller over them—a sort of lateral motion. He himself had seen the curb of a street puff up by the passage of a steam roller 3 or 4 feet from it; and in that case there must have been a lateral motion of the soil underneath the surface. He had a 2-foot main laid some little time ago, and the trench was filled up during wet weather. No portion of it was less than 4 feet deep; and yet the pressure of the steam roller lifted the pavement 5 feet away. This must have been a lateral motion. Gas pipes should be laid very carefully. He thought Mr. Warner's paper would be worth perusal, and they would no doubt profit by it.

Mr. Pettigrew said that at the last meeting of the Association he put before the members a pipe modelled to prevent drawing, and he thought it would be a very good thing to design a pipe which, when it moved in a lateral direction would tighten itself.

Mr. Warner showed a service pipe which had been drawn from the socket and burnished by the action it had undergone. He thought the burnishing must have been done by moving backwards and forwards. He exhibited it, he said, just as it was removed from the ground; and it was proof positive that there must have been vibration upon it. This was not the only case. He had one similar to it; and on looking through some pipes on the previous day he saw there were others. It was not simply a breakage; but a breakage first and then a vibration upon it. Alluding to Mr. Ford's remarks, he said it would be almost a matter of impossibility to take up 60, 80 or 100 miles of mains and relay them. But, of course, as mains were relaid, or new ones were being laid, precautions could be taken to place them at a greater depth. As, however,

their President had remarked, this would not meet their case entirely. Though he went down 4 feet, yet there were deeper trenches—sometimes three times that depth—for sewage pipes. It would not avail them to go further down, unless care were taken in filling in the trenches. The nature of the ground had something to do with it, undoubtedly. A surveyor of a Tyne district told him a short time since that he knew of a case where a steam roller sank to below the axle. If this were to happen how could their pipes escape damage? He congratulated Mr. Ford upon his being able to bring his unaccounted-for gas so low. He did not know that it was a general experience; but he himself nearly approached 5 per cent. a few years ago. He, however, found the leakage had been growing year after year since the steam roller began to be used. With reference to this percentage, though it was scarcely the matter under consideration, he might remark that it depended entirely upon how they dealt with it—upon what, for instance, they considered the amount consumed in public lighting. Until they obtained fixed figures for this, he thought they were not able to deal with the percentage except upon broad grounds.

Mr. Ford observed that his decrease had been accomplished under similar conditions to those under which he had 24 per cent. of leakage.

Mr. Warner remarked that there was still the question of whether the quantity had increased or decreased as well as the percentage. He was not altogether clear with regard to Mr. Pettigrew's observations. He thought he showed first that he did not know of any drawing of the joints of pipes.

Mr. Pettigrew said that his remark was that it was the weight—the vertical pressure—which caused a pipe to loosen, not the drawing pressure; that the pressure bent the pipe downwards and generally broke it.

Mr. Warner did not see that, as a rule, the pipes should be broken. It was the joint which gave way. The President's remarks were, of course, above criticism; but he might say that they bore out entirely his own experience in these matters. He thanked the members for their reception of his paper.

Mr. Hall (West Pelton) said he wished to add that he found an efficient method of preventing the drawing of service pipes to be to place (after the connection was made, and the trench filled in to the level of the pipe) several stones alongside the connection, and then when a subsidence took place the pressure came upon the stones, and not upon the pipe. If the place were opened years afterwards there would be a cavity but no fracture. He had found this in numbers of cases. The subsidence did not take place in the solid ground, but where the connection was made.

Gas Engines With Electrical Ignition.

In the report made to the Franklin Institute, by its special delegate to the Paris Exhibition (Mr. Carl Hering) on the electrical exhibits at that exhibition, we find the following respecting gas engines on display that are started by means of electrical ignition:

The ignition of the gases in gas and petroleum engines by an electric spark appears to be coming into use more generally, judging from the large proportion of engines exhibited in which this way is preferred to the gas flame ignition. There were exhibited twenty-one different systems of gas and petroleum engines, counting the various different exhibitors of the Otto engine as one exhibit. Of these, thirteen (or sixty-two per cent.) used electrical ignition, and only eight (or thirty-eight per cent.) used the gas flame ignition.

Historical.—The following abstract regarding the history of electrical ignition is taken from a paper of Mr. Delamère-Deboutteville, read before the Institution of Mechanical Engineers, July 3, 1889. In 1844, John Reynolds used a platinum wire heated by means of a battery. A mechanical contact maker and breaker started and stopped the current at the proper moment. In 1850, Shepherd used an electro-magnetic generator in place of a battery. In 1857, Barsanti and Mattenni used a Bunsen battery, with a de la Rive multiplier, the sparks from which were used. In 1860, Lenoir replaced the de la Rive multiplier by a Rhumkorff induction coil. The primary current passed continually, and the secondary was closed when the spark was required. There was difficulty in timing the spark exactly.

General.—The heated platinum wire is apt to become cooled at the moment of the passage of the gases, and it cannot be timed sharply, besides requiring considerable battery power. It therefore seems to be abandoned. All the engines exhibited used the spark. The chief advantages of the spark over the gas flame, appear to be, its very high temperature, which is of importance, especially when poor gases are used; it is independent of cold or moist air; it reduces the temperature of the valve chest and parts, and thereby facilitates lubrication of those

parts and does away with incrustations there; in some of the systems it can be very definitely timed, which is claimed to be very important as there is said to be a considerable difference in the power if the time of ignition varies one-twentieth of a second. The disadvantages of using electricity in place of the gas flame depend upon the particular system used; in general it introduces something with which the ordinary mechanic is not familiar.

The systems exhibited are here divided for convenience into four classes. All in common use this ignition only, having no means for gas ignition, showing that they can rely entirely on the spark. In all but one, the spark is made to pass in the cylinder, in the other it is in a special chamber. The insulation of the parts entering the cylinder are variously of porcelain, plaster of paris, or asbestos, in order to stand the heat and the mechanical pressure of the explosions.

First System.—In the first system, a battery, generally two or three large Bunsen or bichromate cells, is used with an ordinary Rhumkorff induction coil having a simple hammer vibrator; the vibrator acts all the time while the engine is running, and the spark of the secondary coil is operated by various means. In all of these the spark passes between two *fixed* points in the cylinder. The advantages of this system over some of the others are that there are no moving parts entering the cylinder; that there are numerous sparks generated instead of a single one, as in some of the others; and that the spark can be well timed. The disadvantage is that the vibrator acts all the time, which is bad for the contacts of the vibrator, and consumes battery power continually.

Details.—In the Engine exhibited by E. Rogers (French Section) the secondary circuit is normally open at a sort of switch outside of the cylinder, which is operated by the moving parts of the engine, and is closed the instant the spark is required for the explosion. When the switch is closed the only break in the secondary circuit is in the cylinder, where the sparks are therefore produced. It is evident that no premature explosions can take place.

In the engines of Louis Charon and those of Solomon Freres and Tenting (French Section) the secondary circuit is continually short circuited outside of the cylinder, except the instant when the spark is required. Premature explosions cannot take place unless this short circuiting switch is exceedingly dirty. They used two large cells.

Those of Thomas Powell (French Section) differ essentially from the others, in that the spark passes continually in a spark chamber, which is closed by the slide valve. When ignition is to take place, a port in the slide valve makes this spark chamber communicate with the cylinder, thus igniting the gases. The length of the spark is 1.5 mm., or about one-sixteenth inch. They claim that the instant of ignition can be more accurately and definitely timed by these ports in the slide valve. There is probably more possibility of premature explosions, as in the flame ignition engines, causing it to "sneeze." They use only one cell of two carbon plates in bichromate solution, the zinc being in sulphuric acid in a porous cup.

Second System.—In the second system a battery and induction coil are used as before, but the primary circuit, instead of the secondary, is closed when the spark is required. The vibrator, therefore, acts only while the primary circuit is closed, thus economizing battery power. It has the same advantages as the first system, except that the spark is not so definitely timed, and is not so sure, as it is necessary that the vibrator starts itself and responds promptly; to do this it must be well adjusted, and its contact must be very clean; it is difficult, if at all possible, to clean it while running.

To this class belong the engines of the Societe des Moteurs a Gaz Francais, A. F. Noel (French Section), and of the Societe Anonyme des Moteurs Inexplosibles au Petrole et au Gaz (Belgian Section). In these the primary circuit is operated by a contact piece on the shaft or other moving part, and a brush sliding thereon, usually made adjustable in order to time the spark. The one exhibited by Rouart Freres and Cie (French Section), was a double-cylinder engine, and in addition to the above there was a second contact piece on the revolving shaft connected to the secondary circuit, and having two brushes, the object of which was to switch this secondary circuit alternately to each of the two cylinders. They used only two large one gallon bichromate cells. The frame of the engine was used as a ground return circuit for both the primary and the secondary currents.

Third System.—In the third system a magneto machine is used to generate the spark without an induction coil. The armature of the magneto, usually a simple Siemens H armature, is kept from revolving by a strong spiral spring. For each explosion it is revolved on its shaft through 90° against this spring and allowed to snap back into its normal position, during which rapid return motion it generates a momentary current. An instant after the armature is released, and at the moment

when its current is a maximum, the circuit is broken in the cylinder, producing there a single bright spark. The advantages are that no battery is required, there is no coil with a vibrator to keep in order, and it is always ready to start; as the high rate of rotation necessary to generate the current is produced by a snap movement, no great speed of the engine is required at starting, as would be the case if a dynamo was used in place of a magneto. A disadvantage is that only one spark is produced in place of a number of them as in the other systems, but as it is a much more powerful spark, and quite positive, it does not appear to be an objection. In this system there must be moving parts entering the cylinder to break the circuit there.

The engines of Gotendorf and Cie, and of E. Delahaye (French Section) were of this class. In the latter, the exact time of the spark may be adjusted by a cam movement. The engine of W. C. Horne (British Section) also belongs to this class, it differs from the other two in that the H armature is normally in the stable position into which the magnets would pull it, the spring assisting it to return to the position, while in the other two the normal position is the unstable position, in which it is held against the magnetic pull by the spring, which must, therefore, necessarily be much stronger. The spark is produced between two steel springs in the cylinder, operated by means of a rod passing through a stuffing box. This rod has a rotary motion instead of a longitudinal one, thereby facilitating the construction of the fire-proof stuffing box.

Fourth System.—In the fourth system a dynamo or magneto is turning all the time, generating the current which is broken in the cylinder directly without a Rhumkorff coil. The disadvantages of this system are that in starting the engine, sufficient speed must be produced by hand before the dynamo will generate sufficient current to produce a spark.

In the engine of E. Durand (French Section), a small simple magneto is used generating an alternating current. Both wires are insulated, that is, the frame of the engine is not in circuit. The circuit is broken in the cylinder by a revolving rod, as in the engine of Horne. No self induction coil is used.

In the Baldwin Gas Engine (United States Section) the current is generated by a small shunt-wound dynamo of about one-eighth horse power. It is driven directly from the fly-wheel by a friction pulley, the pressure being produced by its own weight. There are two friction pulleys of different sizes, the smaller one, for high speed, is used only for starting. There is a self induction or spark coil in circuit, and the circuit is closed except when the spark is required. The breaking of the circuit is operated by an insulated pin passing into the cylinder and having a longitudinal motion. It is difficult in this arrangement to keep the contacts in the cylinder clean, especially as the tendency of this particular construction is to destroy its own contact.

Dye's Apparatus for Washing Gas.

On January 28th U. S. Letters Patent (No. 420,378) were granted to Nathaniel C. Dye, of Rutland, Vt., for an improved method and device for washing gas. In his specification the inventor says :

My invention consists of an improved method and a novel apparatus for washing, scrubbing and cooling gas, as will be hereinafter described and specifically claimed.

In the accompanying drawings, Fig. 1 is a vertical central section of

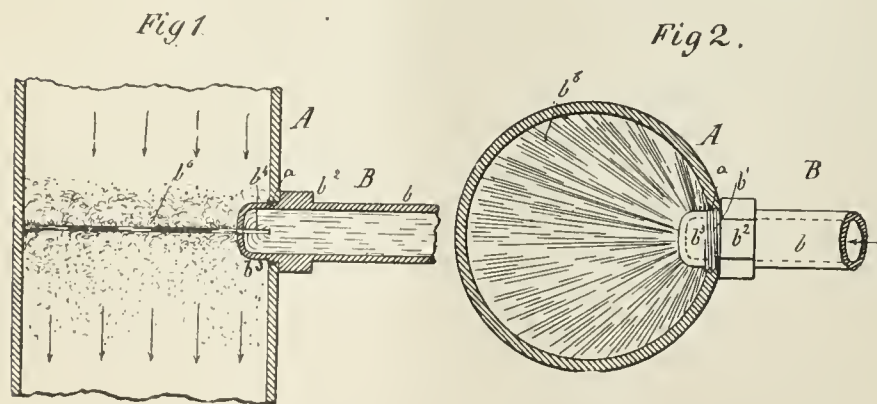

a main gas pipe provided with the improved gas washer, scrubber and cooler; Fig. 2 is a horizontal section of the same; and Figs. 3 and 4 are diagrams of two types of gas generators and purifiers having a main pipe provided with the improved gas washing, scrubbing and cooling apparatus.

The letter A in the drawings represents a main pipe of a gas genera-

tor; B, a gas washer and cooler; G, a gas generator, and C, a gas purifier.

Between the gas generator G and purifier C of a gas works the main pipe A is placed, and it conducts the gas from the former to the latter. Into this pipe A the nozzle portion b of the gas washer and cooler B is secured by means of a screw-thread b' on the said nozzle portion and a corresponding screw-thread a in the pipe A. A prismatic formation b³ on said nozzle portion serves to facilitate the use of a wrench for fastening or unfastening the nozzle portion. The nozzle b³ extends into and slightly beyond the inner surface of the pipe A, and is there provided with a longitudinal slot b⁴, forming a narrow flat orifice, which

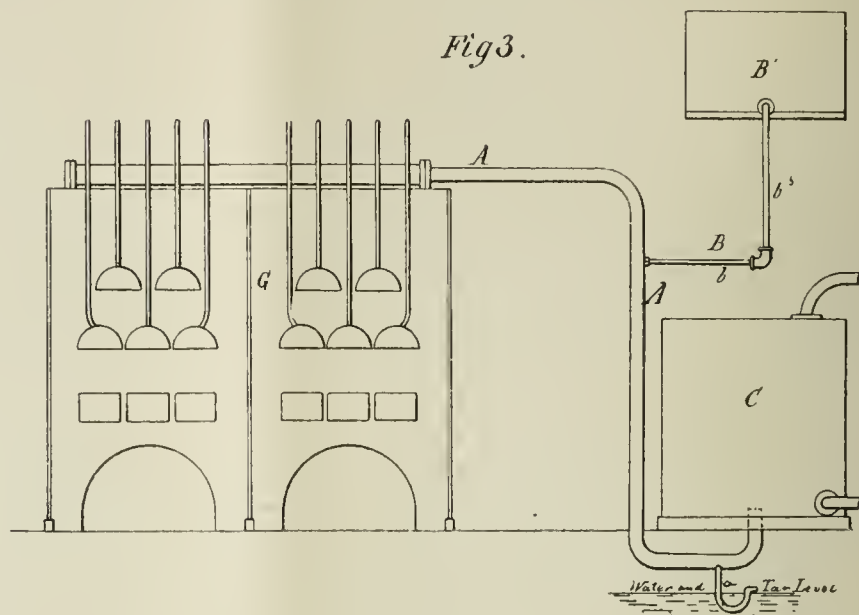

terminates at the inner surface of the pipe A. This nozzle portion b is connected by means of pipe or conduit b⁵ with an elevated reservoir B', from which the water is conducted under pressure through said pipe or conduit b⁵ into the nozzle portion b and through the slot b⁴ into the pipe A, and thus a transverse diaphragm or unbroken sheet b⁶ of water is produced, which strikes the whole inner surface of pipe A, and, rebounding, is dashed into spray in the manner described. Through this diaphragm or water-sheet b⁶ and the spray thereof the gas from the generator is forced, and being thus thoroughly mixed with the same is freed by the current and the spray of such impurities as readily unite with water, and it is at the same time cooled down to such a degree that the remaining tar and nearly all the other impurities are precipitated or concentrated, and thereby separated from the gas.

In connection with the invention it is proposed to use lime as a purifier, the slaked lime being placed in trays or sieves within purifier boxes, and the gas, after having been washed, scrubbed and cooled, as herein described, is passed through the lime on its way from the generator to the gasometer.

The pressure necessary for producing a powerful current of water may be secured from a highly elevated reservoir, a force pump, or other suitable means, and this pressure may be varied to suit circumstances. A pressure of about 65 pounds to the square inch has been found to work very satisfactorily. While the pressure at the head or source of the water is 65 pounds to the square inch, there is very little pressure comparatively in the thin sheet of water which stands across the main gas pipe,

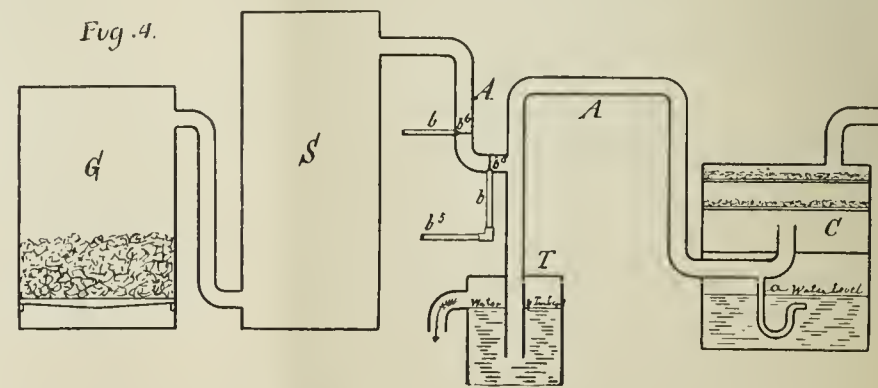

and through which the gas passes from the generator to the purifier, for when the water leaves the end of the nozzle it is in a body of only about one-eighth of an inch thick, as seen in the drawings, and runs off as rapidly as the pressure in the nozzle will cause it to flow, and it is immediately carried away with the condensation of the gas vapor through the siphon at the bottom of the pipe, and thus the gas pipe is always free

from water—accumulated water, which would be liable to retard the flow of gas and cause a back pressure. The resistance of the thin sheet of water is not more than sufficient to keep the sheet in a diaphragm form and in slight contact with the inner surface of the pipe, and thus insure the subjection of the entire volume of gas to the washing, scrubbing and cooling action of the cool water.

If desirable, several nozzles *b* may be employed at suitable distances apart, so that the water will flow through several transverse water sheets *b*⁶ in succession, and thus be subjected to a more effective treatment of cleansing and cooling.

In practice it is often found necessary to run in water gas works about 6,000 feet of gas in 20 to 25 minutes through an 8-inch pipe, and the gas leaves the superheater while it is red-hot, or oftentimes at a white heat. The gas in this condition strikes the diaphragm of water, about 5 feet from the superheater, and hence I generally employ two or more, but sometimes only one, diaphragms of water. This depends upon how fast gas is generated in a given sized generator and under a given amount of heat. When the gas strikes the first diaphragm of water, the water strikes every particle of gas vapor, or nearly every particle. Should there be any vapor that has not come in contact with the first diaphragm and spray from it, the second one would take up what escaped from the first, and so on, according to the number of spaced water diaphragms within and along the pipe between the generator and purifier. The solid sheet or sheets of water completely fill the circular space across the pipe to the extent of the thickness of the sheet or sheets, leaving no space for the gas to pass except it passes through the diaphragm or diaphragms of solid water. This operation is different from that of spraying or jetting water upon gas in the pipe, because the gas in the sprinkling method has freedom, in part, to pass between the jets of water, and thus it is not all subjected to the action of the water in its passage to the purifier.

In the water mains of Rutland, where I have introduced my invention, 65 pounds pressure to the square inch being used, I have found one nozzle sufficient; but where the pressure of the water in the water mains is but 25 pounds to the square inch, two or more nozzles might be necessary. All depends, as above stated, upon the amount of gas generated. It is a very convenient arrangement to apply, as I have shown, one or two nozzles immediately between the gas generator and purifier, as the gas can be washed, scrubbed and cooled, and then at once passed directly into the purifier.

It is obvious that if the gas mains be made of squared or any other appropriate form than cylindrical, the same result of forming a complete diaphragm of water across the pipe would be produced if the slit in the end of the nozzle is extended entirely across the nozzle from the inner surface of the pipe on both sides of the nozzle.

Before entering the purifier the gas is relieved of water and tar by means of an escape or drip pipe *a*, provided in the pipe *A*, which for that purpose enters the purifier from below. This drip cup may be in the form of an inverted siphon, forming a gas trap, which allows only tar and water to escape in the manner illustrated. In Fig. 4 I have shown a construction which I have successfully employed. It consists of a generator *G*, superheater *S*, sealing tank *T*, and lime purifier *C*, supplied with water nozzles *b*, between the superheater and sealing tank. It will be readily seen that the sealing tank serves the same purpose as the above-described inverted siphon drip pipe *a*. Before entering the purifier the gas is again relieved of any water and tar precipitated during its passage beyond the bottom of the purifier by means of an inverted siphon drip pipe *a*, as above described. In this apparatus I may also employ one or more nozzles *b* in the pipe *A* between the generator and superheater, and provide in the lowest portion of the pipe a drip pipe *a* as described.

Progress of the Electric Light in Australia.

Mr. E. J. Erskine, writing on this subject in the London *Electrician*, says the first introduction of the electric light into New South Wales was in 1881, when Mr. H. H. Kingsbury, who two years previously had introduced the telephone into this Colony, carried out an installation of arc lamps at the Redfern railway station for the government. At the present time there are upward of 5,000 incandescent and 500 arcs in the colony. In 1883 the Legislative Assembly was lighted by the same firm with incandescent lamps; Edison machines were used with great success, but lately it has been deemed necessary to increase the light, and new machines of the Manchester type have been installed. But it was really in 1887 that the advantages of the electric light were properly recognized. In this year Her Majesty's Theater Company decided to adopt this system of illumination for their new building, and a plant

for 900 lamps was installed, Manchester machines being used. In 1888 Messrs. Harrison and Whiffen appeared in the field as agents for Crompton & Co., and secured the contract for lighting the town of Tamworth, where they installed a plant on the continuous current system, which has given satisfaction in the town. In 1888, also, an impetus was given to the electric lighting business through the opening of a number of skating rinks in which the proprietors desired to have the electric light; but as these installations were nearly all of a temporary nature, the work was not of a character to be encouraged, switches, cut-outs, ampere or voltmeters being conspicuous by their absence. It would be more satisfactory to all parties concerned if the fire underwriters' rules were more stringently enforced; as, although we have so far been very fortunate in Australia, having had no accidents that could be attributed to the electric light, it is more by good luck than by good management; and now that the number of installations is increasing, it is most necessary that every precaution possible to prevent accidents should be taken.

Last year was a busy year in electrical circles in all the Colonies; in Melbourne, on account of the extensions of central stations, and in New South Wales, on account of the number of country boroughs which called for tenders; but perhaps the most important event of the year was the introduction into New South Wales of the first alternating current transformer plant installed by Messrs. Kingsbury & Co. in Young. This plant is on the Thomson-Houston system, and the success has been such that the firm has received the contracts for Penrith and Lambton. It should, however, be mentioned that although this is the first introduction of the alternating current in New South Wales, both the Thomson-Houston and Ganz & Co. have been working the system in Melbourne for some time with great success.

So far as motive power is concerned there appears to be a general leaning towards engines of the semi-portable type, and it is an exception when a plant is erected with separate boilers and engines. The standard of work done by firms in Sydney has been gradually improving during the last few years, and now it has reached a creditable pitch; the installations at the office of the *Daily Telegraph*, and that in the new hotel in Bent street—being the latest addition in Sydney—are in every respect highly satisfactory; also the temporary lighting of the Centennial Hall with arc lamps reflects great credit on the contractors. Perhaps the first thing that would strike an electrician coming here and going round the different installations would be the deplorable lack of ventilation and space in the engine and dynamo room, with one or two exceptions—a state of things highly detrimental to efficient working of the plant. Architects might be forgiven for not knowing that ventilation is a great advantage in a dynamo room from a commercial standpoint; but they should not lose sight of the fact that the attendant requires air to make it possible for him to look after his machinery. In one case the attendant is nearly suffocated by the fumes from some accumulators. It seems to be the general impression that any hole is good enough for electrical machinery.

Up to the present there is no central station lighting in Sydney; whereas in Melbourne there is a considerable amount of lighting done from the stations in operation, and there are other stations in contemplation. The reason for this difference in progress between the two largest cities in the Southern hemisphere may perhaps be accounted for by the fact that in Sydney the Gas Company has a monopoly of the lighting; and although two bills have at different times been introduced to enable companies to erect central stations and supply light and power, they have never got beyond the first stages, and have then been allowed to lapse. In Brisbane there has lately been a considerable movement toward the electric light; and central stations will, I think, shortly be an accomplished fact in the Northern Colony. If so, Sydney will have been left behind by all her neighbors, as at present there are no rumors of a central station here. However, the New South Wales country municipalities are, to a certain extent, making up for the indifference shown by the metropolis, as at the present time there are two of the interior towns lighted; in three others the work is in progress, and seven others are either considering or calling for tenders. Under these circumstances it must be admitted that the outlook is very promising.

So far as traction is concerned, very little has been done in any of the colonies. Some time ago a trial was made of a car on the Julien principle, but, although the trial was successful, nothing more was heard of it. At the present moment an electric tramway is talked of for Balmain, a suburb of Sydney, and I believe it is to be on the Sprague system. Victoria once more takes the lead in the matter of electrical tramways, having one at Box Hill which is giving satisfaction, although I hear the rails through which the return is made are not all that could be desired, the joints being very primitive, and therefore the resistance very great.

There is one matter that is doing a considerable amount of damage to the electrical industry. I refer to the exaggerated reports that appear from time to time in the daily papers, copied from home papers, of the dangers of electric lighting in general, and of overhead wires in particular. Many persons in the country districts reading these articles immediately imagine that the introduction of the electric light is nothing more or less than the introduction of a new kind of plague.

The subject perhaps most under consideration here at present in the country municipalities is whether arc or incandescent lighting should be adopted for street lighting. The great argument relied on by the advocates of arc lighting is, that whereas it requires 500-horse power to obtain 100,000-candle power with incandescent lamps, the same number of candle power would be obtained with 50-horse power with arc lamps. Of course this is absurd; but they will not understand that the two systems cannot be compared by their nominal candle power. So far the five municipalities who have decided on the electric light have adopted the incandescent with good results, and it certainly hardly seems necessary in towns of 6,000 inhabitants to go to an enormous expense of lighting the town with arc lamps, the night traffic being quite insignificant.

In Victoria the railway authorities are turning their attention to lighting their trains by electricity, and once more the younger Colony will be ahead of New South Wales, as the system now in vogue here is an elaborate system of gas illumination, the installing of which involved a large outlay; and it is, therefore, not probable that the authorities will, for some time, at any rate, consider the question of electric lighting, which would necessarily entail another large expenditure.

The prospects of electric lighting in the other Colonies, viz., New Zealand and Tasmania, should be very good, the abundance of water power which is at the disposal of engineers giving every opportunity for the electric light to compete with any other system of illumination.

The Identity of Light and Electric Radiation.

According to the *Gas World*, during the past couple of years a very remarkable series of investigations has been carried on by Prof. Hertz, of Berlin, on the above subject. The phenomena of induction—an object at a distance becoming electrified across the intervening space through the influence of a charged body—are very well known, and are, indeed, quite familiar; and Clerk Maxwell showed, 25 years ago, that this action is not, as gravitation appears to be, instantaneously propagated throughout space, but travels with a definite velocity; and he went on to measure this velocity by methods with which we need not concern ourselves here, but which brought out the startling result that the velocity of propagation of electric induction is the same, at least within one per cent. or so, as the velocity of light. On the other hand, it is known that heat, light, and the ultra-violet radiation present us with a series of ether waves, the length of which ranges from $\frac{1}{1000000}$ to $\frac{1}{100000000}$ inch. But there ought to be circumstances under which less frequent waves than these—waves of greater length—would be formed; and if they were formed they would obey the same wave-motion laws as are followed in the phenomena of light, radiant light, and actinic radiation. Up to Hertz's researches, however, these longer ether-waves had not been observed, though Clerk Maxwell's result afforded a very emphatic hint in what direction to look for them. Hertz has found them; and by so doing he has added another to the links which bind the various parts of physical science into one general science of matter and energy. Lecturing lately in Berlin, Hertz gave an account of some of his experiments; and we propose to give our readers a short sketch of the interesting results at which he has arrived.

After overcoming some considerable preliminary difficulties in realizing the results which he foresaw, Hertz succeeded in arranging two conductors so that a continuous spark jumped across the 0.12-inch space between them, and in producing, in a similar gap between two wires, a spark due to induction. This secondary spark was sometimes increased by putting a reflecting wall of metal or other conducting material behind the primary spark; but it was sometimes diminished and brought to naught; and the maximum spark was produced when the reflecting wall was at about 6.6 or 19.8 inches behind, the minimum when it was at about 13.2 inches; whence it followed that the phenomena of wave interference were in play, and the wave length was about 26.4 inches. By the use of a zinc mirror, of parabolic form and large size, with the primary spark at its focus, the reflection was rendered more manifest; and by means of such a mirror and an opposite reflecting metallic plate, as many as four model points can be obtained in the axis of the mirror. At each of these there is no effect on the secondary wires when there placed, and midway between them the spark-inducing action is at its maximum. The wave length being 26.4 inches, the number of com-

plete waves must be (taking the velocity to be the same as that of light) $\frac{1}{2}$ thousand millions per second—very much less frequent than the slowest heat wave yet observed (20 million millions per second). In wires the wave length appears to be only 23.2 inches; somewhat less than in air. These phenomena only occurred in the axis of the mirror, just as with light, and Hertz felt justified in speaking of electric radiation.

But then, having got so far, he proceeded to see whether this electric radiation was subject to the ordinary well known optical laws.

He first tried to produce shadows, and found that with a metallic screen of zinc, tinfoil, or even gilt paper, the radiation could be obstructed; but that it traversed insulators, such as a wooden door, which are therefore transparent to it. There were phenomena pointing towards diffraction; there was no sharp shadow; indeed, there could not have been, any more than sound waves of the same length (about B in the treble clef) could produce a sharp shadow on a small screen.

The next step is a decidedly astonishing one—namely, the discovery of the polarisation of the electric radiation. The conductors producing the primary spark were arranged parallel to one another and vertical; then the throbs in the conductors were vertical; the throbs in the primary spark were vertical; and hence the radiation waves were up and down ones. Keeping that in view, the mirror may be so shaped that two such mirrors will, in the crossed positions, act like a polariser and an analyser in polarised light; and a piece of tourmaline, to be placed between these "crossed prisms" so as to restore some light, may be imitated by means of a wooden framework over which are stretched parallel wires. Just as in the optical phenomena light is seen to pass through or to be shut off, so here the waves were either allowed to pass and produce the secondary spark, or else were cut off while the secondary spark disappeared. Hertz concludes from some other phenomena that, not only is there an electric disturbance in the vertical plane in the case supposed, and at right angles to the ray, but that there is also at right angles to the electric undulation, and also to the ray, a magnetic periodic disturbance; which is exactly a somewhat unintelligible phenomena predicted by Clerk Maxwell in ordinary light.

After polarisation, reflexion is easy to understand. We have already seen phenomena of reflection in this series of experiments; Hertz has established the fact that the law of equality of the angles of incidence and reflexion is obeyed by conducting mirrors.

Refraction, too, may be rendered manifest by the use of a huge prism of hard pitch, which is transparent to the waves, but refracts them as if they were light waves passed through a prism whose refractive index is 1.69; the optical refractive index of bodies of this class is between 1.5 and 1.6; but this divergence is not great, when regard is had to the experimental difficulties and the crudity of the material employed.

There is about all this a simplicity and directness which give it high rank as an experimental research.

Spontaneous Combustion in Coal Ships.

[Read by Prof. Vivian Lewes at a meeting of the English Institution of Naval Architects.]

The author first referred to the Royal Commission of 1875, and stated that in the nine years following the report 57 coal laden vessels were known to have been lost from the spontaneous ignition of their cargoes, while 328 were missing from unknown causes. It is said that the increase of steam pressure and consequent increase of temperature has made spontaneous ignition of coal cargoes more likely to occur. The paper next dwelt with the composition of coal, pointing out that its volatile constituents or hydrocarbons consist essentially of compounds containing carbon and hydrogen, together with a little oxygen and nitrogen. The ash which is left after the coal is burnt consists chiefly of sulphate of lime or gypsum, silica, and alumina, whilst in nearly all coal is to be found iron disulphide, known as coal brasses or pyrites. This has been formed by the gradual reduction of the sulphates by carbonaceous matter in the presence of iron salts. Of these constituents of coal the only ones which play no part in spontaneous heating are the mineral constituents other than the pyrites.

Carbon possesses to an extraordinary degree the power of attracting and condensing gases upon its surface, this power varying with the state of division and density of the particular form of carbon used. The absorptive power of newly-won coal varies, but the least absorbent will take up $1\frac{1}{2}$ times its own volume of oxygen, whilst in some coals more than three times their volume of the gas is absorbed. This absorption is very rapid at first, but gradually decreases, and is influenced very much by temperature. The absorption is at first purely mechanical, and itself causes a rise of temperature, and the rate varies with the amount of sur-

face exposed, so that when coal or charcoal is finely powdered, absorption becomes more rapid, and rise of temperature at once takes place. If charcoal is kept for a day after it has been made, out of contact with air, and is then ground down into a powder, it will frequently fire after exposure to air for thirty-eight hours; while a heap of charcoal powder, of 100 bushels or more, will always ignite. In the case of coal, this rise in temperature all tends to increase the rate of the action which is going on; but is rarely sufficient to bring about spontaneous ignition, only about one-third the amount of oxygen being absorbed by coal that is taken up by charcoal, while the fact of the action being much slower, tends to prevent the temperature reaching the high ignition point of the coal. Air-dry coal absorbs oxygen more quickly than wet coal.

The action of the bituminous constituents is next considered in the paper. All coal contains a certain percentage of hydrogen, which is in combination with some of the carbon, and also with the nitrogen and oxygen, and forms with them the volatile matter in the coal, and the amount present in this condition varies very largely, being very small in anthracite and very great in cannel and shale. When the carbon of the coal absorbs oxygen, the compressed gas becomes very chemically active, and very soon commences to combine with the carbon and hydrogen of the bituminous portions, converting them into carbon dioxide and water vapor. This chemical activity increases rapidly with rise of temperature, so that the heat generated by the absorption of the oxygen causes it to rapidly enter into chemical combination, which is accompanied by evolution of heat, and this further rise of temperature again increases rapidity of oxidation, so that a steady rise of temperature is set up. This taking place in the centre of a heap of small coal, which, from the air and other gases inclosed in its interstices, is an admirable non-conductor of heat, will often cause such heating of the mass that if air can percolate slowly into the heap in sufficient quantity to supply the necessary percentage of oxygen for the continuance of the action, the igniting point of the coal will be soon reached.

The action of pyrites is next considered by the author. It is found in coal in several different forms, sometimes as a dark powder distributed throughout the mass, or in larger quantities forming thin golden-looking layers. Sometimes it occurs as large masses and veins, often 1 in. to 2 in. in thickness, but these masses rarely find their way into the screened coal for shipment. If the air is dry the pyrites undergo but little change at ordinary temperatures; but in moist air they rapidly oxidize when in a finely divided condition, the first action being the formation of ferrous sulphate and sulphur dioxide, together with the liberation of sulphur, the relative amounts of the two latter being regulated by the temperature and the supply of air, whilst longer contact with moist air converts the ferrous sulphate into a basic ferric sulphate generally termed "misy." It is during this process of oxidation that the heat supposed to cause the ignition is evolved. But when it is considered that some of the coals most prone to spontaneous combustion contain only eight-tenths of a per cent. of iron pyrites, and rarely more than 1½ per cent. the absurdity of imagining this to be the only cause of ignition becomes manifest. If 100 pounds of coal were taken, and the whole of the pyrites in it concentrated in one spot and rapidly oxidized to sulphate, the temperature would barely be raised to 100° C., if all loss of heat could be avoided.

The author had carefully determined the igniting point of various kinds of coal, and found that—

Cannel coal	ignites at 698°	F. = 370° C.
Hartlepool coal	" 766°	F. = 408° C.
Lignite	" 842°	F. = 450° C.
Welsh steam coal	" 870.5°	F. = 477° C.

So that no stretch of imagination could endow the small trace of pyrites scattered through a large mass of coal, and undergoing slow oxidation, with the power of reaching the needful temperature.

Dr. Richters fully realizes this point, and discards the idea of the pyrites doing anything more than adding their mite to the causes which bring about rise of temperature. In this, however, Professor Lewes thinks he is mistaken, his (Prof. Lewes') experiments pointing to the fact that the pyrites may increase the liability to ignition when present in large quantities, and do so by liberating sulphur under certain conditions. Sulphur has an igniting point of 482° F., or 250° C., so that the presence of free sulphur would lower the ignition point of the coal by considerably over 100° C. Also the pyrites as they become oxidized to ferrous sulphate swell in size, and so tend to split up the coal into small pieces, and by extending a large extent of fresh surface to the air cause energetic chemical action.

On examining the evidence to be obtained as to the conditions under which spontaneous ignition of coal in ships usually takes place, it is found that liability to ignition increases with:

1. The increase in tonnage of cargoes.

Thus, in cargoes of under 500 tons the cases reported amount to a little under ½ per cent. for shipments out of Europe; from 500 to 1,000 tons, to over 1 per cent.; from 1,000 to 1,500 tons, to 3.5 per cent.; 1,500 to 2,000 tons, to 4.5 per cent.; and over 2,000 tons, to no less than 9 per cent.

a. The larger the cargo the more non-conducting material will there be between the spot at which heating is taking place and the cooling influence of the outer air.

b. The larger the cargo the greater will be the breaking down action of the impact of coal coming down the shoot upon the portions first loaded into the ship, and the larger, therefore, the fresh surface exposed to the action of the air.

2. The ports to which shipments are made; 26,631 shipments to European ports in 1873 only resulting in 10 casualties, whilst 4,485 shipments to Asia, Africa, and America gave no less than 60.

This result is partly due to the length of time the cargo is in the vessel, but a far more active cause is the increase in the action brought about by the increase of temperature in the tropics.

3. The kind of coal of which the cargo consists. The author is of opinion that East Coast coal is more dangerous than South Wales coal; but so much depends on the amount of small coal present that a well-loaded cargo of any coal would be safer than a cargo of Welsh steam coal in which a quantity of dust had been produced during loading. The idea that the percentage of pyrites present is any indication of the liability to spontaneous combustion must be entirely discarded, as experiment shows that many coals poor in pyrites frequently ignite, whilst others rich in them are perfectly safe.

A much surer guide is to be found in the quantity of moisture present in an air-dried sample of coal, which is a sure index to the absorptive power; the higher the amount of moisture held by the coal after exposure for some time to dry air, the greater will be its power of absorption for oxygen, and the greater, therefore, its liability to spontaneous heating and ignition.

4. The size of the coal; small coal being much more liable to spontaneous ignition than large, on account of the increased surface exposed.

5. Shipping coals rich in pyrites whilst wet; which increases the rapidity of disintegration.

6. Ventilation of the cargo. The so called ventilation which has from time to time been introduced into coal ships is undoubtedly, the author says, one of the most prolific causes of spontaneous ignition. For ventilation to do any good, cool air would have to sweep continuously and freely through every part of the cargo (a condition impossible to attain), whilst anything short of that only increases the danger, the ordinary methods of ventilation supplying just about the right amount of air to create the maximum amount of heating. The reason of this is clear. A steam coal absorbs about twice its volume of oxygen, and takes about 10 days to do it under favorable conditions; and it is this oxygen which in the next phase of the action enters into chemical combination and causes the serious heating.

7. Rise in temperature in steam colliers due to the introduction of triple expansion engines and high-pressure boilers. It has been fully pointed out that anything which tends to increase the initial temperature increases the rapidity of chemical action. The average increase of temperature in the stokehold in two of the Indian troopers from the use of the triple expansion engines was found to be about 5°.

Having discussed the chemical and physical conditions which lead to "spontaneous ignition," the author proceeds to formulate precautions.

The coal should be large, and it is better if free from pyrites. When air-dried it should not contain more than 3 per cent. of moisture.

No coal should be shipped to distant ports until at least a month has elapsed since it was brought to the surface at the pit's mouth. Every precaution should be taken to prevent breaking up the coal whilst being taken on board, and on no account must any accumulation of fine coal be allowed under the hatchways. When possible the coal should be shipped dry.

The coal compartments should be made gas-tight, as far as the bulkheads separating them from the rest of the ship is concerned. When the coal has all been taken in, it should be battened down, and the hatches should not be again opened until the vessel reaches her destination, the only ventilation allowable being a 2-inch pipe just inserted into the crown of each coal compartment, and led 12 feet up the nearest mast, the top being left open. This would be quite sufficient to allow free egress to any gases evolved by the coals, but would not allow undue access of air. The author next proceeded to describe an automatic alarm apparatus he had devised for indicating when the temperature in a cargo of coal had risen to a dangerous extent. It consists of a long bulb of

glass, containing mercury, and has an insulated wire inserted into the quicksilver, and making contact with it, whilst the stem attached to the bulb has a second wire in it, so arranged that when a rise of temperature causes expansion of the mercury, in rising in the tube it makes contact, and the wires from these tubes are in connection with an electric bell, index board, and battery in the captain's room. The author also describes an arrangement of flasks containing liquid carbonic acid gas which he proposed to distribute in the coal cargo. These flasks would be closed by an alloy, which would fuse at 200° F. In this way the gas would be liberated upon the coal becoming heated to a dangerous extent, and the intense cold produced by the expansion of the liquid into gas would cool down the coal to a safe temperature.

When once coal in a cargo has fired, pumping in water is of practically no use, as the fire is, as a rule, near the bottom of the mass of coal, and the flow of the water is so impeded, that in percolating through the interstices of the heated coal, it is converted into steam before it can reach the seat of combustion. The most effective way to apply water would be to have four 3-inch pipes laid along the floor of the coal compartments, about 6 feet apart, these tubes having a $\frac{1}{4}$ -inch hole bored in the upper side every foot or so, and each pair of pipes coming through the bulkhead, and connecting on to two 6-inch pipes passing through the side of the vessel, the sea water being prevented from entering by means of screw valves. As soon as the alarm thermometer gave notice that heating had reached a dangerous point, these valves could be opened and the lower portion of the cargo drenched with salt water. This, evaporating rapidly, would give large volumes of water vapor, which, passing up through the heated coal, would lower its temperature. It would be found beneficial to dress the coals with a little tar or tar oil, which would close the pores and to a great extent prevent oxidation.

The discussion on Professor Lewes's paper was commenced by Dr. Elgar, who referred to a paper he read on "Losses at Sea" at the Liverpool meeting of the Institution in 1886. In that paper he had pointed out that the number of lives lost in coal-laden vessels, of over 300 tons, during the period of 1881 to 1883, was more than one-third of the total number lost in all the foundered and missing ships. The author stated in his paper that: "In the nine years immediately following the report of the Royal Commission on Spontaneous Ignition of Coal Cargoes, viz., 1875 to 1883, 57 coal laden vessels were known to have been lost from spontaneous ignition of their cargoes, while during the same period 328 were missing from unknown causes, a large percentage of these losses being undoubtedly due to the same cause; and these again, form but a very small percentage of the cases in which the cargoes have heated and fired, but in which the vessels have been saved."

The speaker pointed out, with regard to the 328 vessels thus lost that there were other dangers attending coal cargoes besides spontaneous combustion, such as explosions of coal gas, shifting of cargo, collision, etc. From the paper he read at Liverpool, it would be seen that out of all the known losses registered during three years, 23 only were due to spontaneous combustion of coal, and of these 22 were sailing vessels, and only one a steamer. The speaker pointed out that many of the sailing ships thus lost were built of wood, and that wooden ships could not be kept dry, and he asked if the wet would not tend to generate heat in a coal cargo. Out of 86 coal laden vessels reported as foundered and missing, 33 were steamers and 24 of these went down with all hands. The remaining 9 were lost by springing leaks at sea or by shifting of cargo and taking in water through the deck openings. Sixteen of the remainder were iron sailing ships, and of these 11 went down with all hands, and 3 were lost through shifting of cargo. There were also 34 wood and 3 composite vessels. Dr. Elgar further pointed out that the firing of coal cargoes was not often the cause of loss of a ship or of the lives of the crew, notwithstanding the imminent peril in which ships are often placed in consequence. It took a considerable time for the fire to fully develop itself, and it appeared to be generally possible to get the ship into port. All ships registered in the United States were obliged by law to have steam pipes fitted throughout the holds for extinguishing fire, and the speaker was of opinion that some similar arrangement could be used with advantage in coal laden vessels.

CORNING, this State, is to have public electric lighting, the Mayor having been instructed to close a contract with the Corning Gas Company, under which the corporation is to maintain 50 arcs (1,200-candle power), to burn all night, and to be paid for at the rate of \$100 each per annum. The contract is to last for 5 years, and the Company agrees to have the system in operation on July 1st.

ITEMS OF INTEREST FROM VARIOUS LOCALITIES.

MR. J. D. HIGGINS, Superintendent of the Rome (N. Y.) Gas Light Company, has completed the betterments to that plant, and the result is apparent at every gas burner tip in the city. He planned the scheme carefully and carried it out with dispatch.

AT the annual meeting of the South Side Gas Company, of Pittsburgh, Pa., the following officers were elected: President, George Trautman; Secretary, W. H. Aldred; Treasurer, W. L. Elkins, Jr.; Directors, George Trautman, W. H. Aldred, Robert Brown, M. Maloney, Geo. W. Elkins, Joseph Stewart, Dr. John M. Dixon, Joseph G. Walters and R. V. Messler.

MR. LEON APPERT not long since described before the Societe d'Encouragement (France) a method for manufacturing glass pipes of large size for the distribution of gases, liquids, etc., and claimed that under his system the mains could be manufactured at a fairly low cost. The advantages claimed for glass pipes in this connection are non-porosity and negative electric conducting property. Again, the smoothness and non-porous character of the material enable the pipes to be cleaned easily. The weight of the glass pipes, too, is not so great as that of cast or wrought iron pipes.

ACCORDING to the Burlington *Hawkeye*, from which paper the following particulars are taken, it is a settled fact that Burlington, Ia., is to have a fuel gas company. Continuing, our authority says: "That was settled on the 5th inst., when a body of influential citizens met at the parlors of the Commercial Club and associated themselves together and signed the articles of incorporation of the new Company. The latter will be known as the Citizens Fuel Gas and Lighting Company, of Burlington, Ia., and its object the manufacture and sale of gas for power, fuel, lighting and other domestic purposes to the citizens of this city and vicinity. For this purpose it shall have power to acquire, receive and hold from the city such franchises, charters and rights as may be agreed upon, including the right to occupy the streets and alleys and public grounds of the city for the laying down of street mains and the erection of public lamps; also to hold and acquire the necessary real estate, and generally to do and perform everything necessary to be done in order to properly and successfully establish, carry on, conduct and maintain the business proposed. The life of the Company began May 5th, and is to continue for 20 years. The authorized capital stock is \$300,000, and the Company may commence business when \$100,000 is subscribed. After commencing business new stock may be subscribed only as authorized by vote of the shareholders. Shares are of the value of \$100. The Company is under the control and management of a Board of Directors, to be 5 in number. The officers will consist of a President, Vice President, Secretary and Treasurer. The annual meetings are to be held on the second Wednesday of January in each year. The highest indebtedness shall not exceed two-thirds of the capital stock, and the private property of the stockholders shall be exempt from corporate liabilities. The incorporators are W. D. Gilbert, M. A. Johnson, Chris. Mathes, Chris. Starker, James W. Smither, Chris. Geyer, D. D. Robinson, R. M. Raab, T. W. Barhydt and Philip M. Crapo. These names are a satisfactory assurance that the new Company is on a solid foundation and in the hands of men who will do all in their power to make the project a success. Mr. Branch, representing the Fahnehjelm Company, of Chicago, has been in the city in consultation with the present incorporators, and to him is due in great measure the success of the enterprise. This Company has offered entirely advantageous terms and has done everything possible to assure the members of the Burlington Company of the practicability and economy of the Fahnehjelm system. A petition was presented to the Council last night by Alderman Epstein setting forth the fact that the Company had been formed in answer to the popular demand for a cheaper illuminant, and that the Burlington Gas Light Company had declared they could not furnish their product at lower prices than now received. They, therefore, asked that a Committee of the Council be appointed to confer with the Fuel Gas Company for the purpose of determining what franchise, contracts, rights or other privileges could be granted the new Company. The committee appointed consists of Messrs. Epstein, Mercer and Bonn, who may be depended upon to make every reasonable concession to the new Company. It is the expectation that a franchise will be asked for at the next regular meeting of the Council. We believe but few realize fully the significance of the step taken by the Fuel Gas Company. Not only will the cost of gas for fuel and illumination be cut in halves, which will effect a large saving to the consumer, but manufacturers will be attracted to a place

where they can obtain such a low priced, pure and convenient fuel. It is a matter upon which the city as a whole may well congratulate itself not only for the direct benefits to be derived, but as an evidence of the enterprise and prosperity of her citizens. This is a trump card, which commercial agent Merrill will not fail to play to advantage in his approaching onslaught on the eastern manufacturers. No one is more delighted over the result than Mr. Merrill. He has labored assiduously to bring it about, and is now planning how to make use of it to further other interests. We welcome the new Company, and predict for it a brilliant and prosperous career." All of which is submitted as evidence that it is easy to gull some folks, even though the latter be engaged as newspaper agents in promoting the "best interests of an enterprising city!" The delightful childishness of the Hawkeyed Man, in respect at least to the blessings disguised in the shape of opposition gas charters, is simply touching. The old Company that knows to a dot the capacity for gas absorption of the city, cannot sell gas at anything like the figures that new hands to the business in the district are prepared to dispose of it when "they are ready," etc. Mr. Branch, we are told, "has done everything possible to assure the members of the (new) Burlington Company of the practicability and economy of the Fahnehjelm system. "Well, why could not Mr. Branch have used his powers of persuasion on the old Company, that was already in the field." Perhaps this might be answered in the remark that the old Company already knew the flimsiness of the wares that Mr. Branch had for sale; again, that Mr. Branch thought with good reason he would have better success with "green enthusiasts" than with seasoned operators. The long and short of it is that Burlington is to be appealed to to support a set of schemers, who have, however, so far not been very successful in the matter of "finishing" their dupes. In taking leave for the present of this case we must say we are one with our *Hawkeye* cotemporary in his belief that "but few realize fully the significance of the step taken," etc.; they will, however, get a better appreciation of the step and its tendency at some future time, say, for instance, when the final settlement is made in the adjustment between the conflicting capitalists—always providing that the Fuel Gas Company will assume other shape than that of an enterprise on paper.

MR. W. W. PRICHARD, of the Ironton (Ohio) Gas Company, writing under date of the 8th inst., says that there is nothing either new or strange in the gas business in his locality. Business there, however, is good, with a satisfactory increase over last year.

DISPATCHES from Peoria, Ills., say that Governor Hill, of New York, has granted the requisition asked for in the case of Lafayette Cole, who is charged with absconding with \$6,000 of the moneys of the Peoria Gas Light Company, of which corporation he was Secretary and Treasurer. Cole, after a preliminary hearing, was admitted to bail in \$7,000.

AT the annual meeting of the stockholders of the Cincinnati (Ohio) Gas Light and Coke Company the only change made in the former Board of Directors was the selection of Samuel J. Broadwell to fill the vacancy occasioned by the death of T. D. Lincoln.

THE proprietors of the Woodstock (Vt.) Gas Company have at last determined to rearrange and improve their distributing system.

"THE stockholders of the Perth Amboy (N. J.) Gas Light Company held their annual meeting on the afternoon of the 5th inst., and the following gentlemen were in attendance: Patrick Connery, J. Kean, Jr., U. B. Watson, Wm. Hall, Geo. A. Seaman, N. C. J. English, David Hayes, J. L. Kearney, W. H. McCormick, Wm. Ahrens and M. A. Brown. After the reading of the annual reports, the first five on the above list were nominated and elected Directors for one year. At a subsequent meeting of the Directors Mr. Connery was elected President, and Mr. Hall Secretary and Treasurer. Messrs. Watson and Seaman were instructed to consider and report on the advisability of engaging a Superintendent. I am pleased to note this determination, even though it is arrived at at a rather late period.—R. T. S."

Mr. A. G. Glasgow, who has been connected with the Kansas City (Mo.) Gas Light and Coke Company for the past two years, has resigned in order to take the General Inspectorship of the United Gas Improvement Company. He is succeeded in Kansas City by Mr. Geo. S. Clarke. A notable incident connected with Mr. Glasgow's departure from Kansas City was his reception at the depot, just before the arrival of the train that was to convey him East, by a deputation of employees from the Gas Company, who handed him a handsome silk umbrella. Mr.

Clarke made the presentation speech, and to say that Mr. Glasgow was surprised over the affair is to put it very mildly.

THE following explains itself: "ST. JOSEPH GAS AND MANUF'G CO., ST. JOSEPH, MO., MAY 5, 1890.—Dear Sirs:—I have this day resigned the position, heretofore held by me in this Company, of Secretary and Treasurer, in order to devote all my attention to my own business in St. Louis, Mo., where I shall hereafter be associated with Mr. John G. McNair, in real estate and loans. I bespeak for my successor, Mr. Jas. O. Starks, the same kindness you have always extended to me in my business relations. Very truly yours, J. H. FARISH." We are sorry to lose Brother Farish from the ranks, and Mr. Starks can always command us.

A SLIGHT fire occurred on the 6th inst., in the generator room of the Jackson (Mich.) Fuel Gas Company's plant. The damage was confined principally to the roof. Loss about \$600.

THE annual meeting of the Metropolitan Gas Light Company, of Elizabeth, N. J., resulted in the following choice of officials: Directors, Chas. G. Francklyn, Richard Irwin, John W. Gordon, W. Lewis Boyle, G. Wredenfield, C. K. Dutton, W. M. Oliver, Jas. S. Green and Henry Mactier; President, Chas. G. Francklyn; Secretary, W. M. Oliver; Treasurer, Wm. F. Van Pelt. The determination was reached to go right on with main extensions, and it was the general opinion of the officials that the Company would be ready to supply gas on July 1st. September 1st would be nearer the mark, we think.

THE mains of the New Britain (Conn.) Gas Company are being extended through Bassett, Division, South Main, Whiting and Maple streets. In fact, from the reports that we have of work of this kind from almost all sections of the country, it would seem as if we were to have a regular boom in the matter of increased sendout.

THE capital stock of the Mansfield (Ohio) Gas Light Company has been increased to \$150,000 from \$90,000.

AT the annual meeting of the Altoona (Pa.) Gas Company, the following officers were chosen: President, John Lloyd; Treasurer, W. D. Couch; Managers, W. H. Wilson, Enoch Lewis, H. C. Dern, T. Blair Patton and R. E. Pettit.

THE Syracuse (N. Y.) Gas Light Company, as an earnest of its disposition to deal in the future as it has in the past with the residents of its city, is out with an announcement that on and after June 1st the gross rate to ordinary consumers will rule at \$1.60 per 1,000 cubic feet, subject to a discount of 20 cents per 1,000 when bills are paid on or before the 15th of the month in which they are presented. The price to the city is to rule at \$1.30 per 1,000. We congratulate the Company and its guiding genius, Mr. A. C. Wood, on this latest proof of good business management.

THE employees of the Peoples Gas Light Company, of Manchester, N. H., have demanded an increase of wages, the increase asked for averaging about 25 cents per day. The proprietors are averse to granting the concession, and the men assert that if their demand is not acceded to a strike will be the result.

MR. CHARLES MONSON, of New Haven, Conn., who died at his home in that city on the 5th inst., at the advanced age of 90, will be remembered by gas men as the inventor of the extension gas fixture. He was a brother of the late Dr. Alfred Monson.

AT the annual meeting of the Bangor (Me.) Gas Company the following Directors were elected: T. U. Coe, F. A. Wilson, A. C. Hamlin, C. P. Stetson and John F. Colby. At the Directors' meeting the following officers were chosen: President, T. U. Coe; Secretary, W. S. Dennett; Clerk and Treasurer, Henry Boardman; Superintendent, A. H. Parker. The Company prospers despite the attempted competition of electric lighting.

THE "small boy" and the larger hoodlum in the Wollaston district of the Quincy (Mass.) Gas Company possess a decided antipathy to glass-encased gas lanterns, for the breakage to the latter is simply enormous. The Company, however, must be to blame for this state of affairs, since it could easily under the law bring the offenders to their senses. The Public Statutes, chap. 203, sec. 76, provide that "whoever wilfully or maliciously extinguishes a lamp, or breaks, or mutilates, or destroys, or removes a lamp or lamp post erected on a bridge, sidewalk, street, high-

way, court or passage, shall be punished by imprisonment in the jail not exceeding 6 months, or by a fine not exceeding \$50."

THE Pacific Gas Engine Company has been incorporated at San Francisco, Cal., by Messrs. Wm. G. Barrett, C. L. Barrett, E. C. Bartlett, W. A. Cavanaugh and John L. Boone. It is capitalized in \$100,000.

BECAUSE of the fall of an elevator at the Potrero Station of the San Francisco gas works two employees (Terence Hoey and Edward Kelly) were badly injured. While ascending the elevator, which was raising a heavy load of coal, at a height of 30 feet above the ground, a part of the machinery gave way and the men were thrown to the bottom of the shaft.

AT a meeting of the stockholders of the Peoples Gas and Gaseous Fuel Company, of Harrisburg, Pa., the following Directors were elected: David Flemming, Jr., T. D. Greenawalt, W. T. Hildrup, W. W. Jennings, S. J. M. McCarrell, W. T. Hildrup, Jr., Wm. T. Kirk. The officers chosen were: President, David Flemming, Jr.; Secretary and Treasurer, Geo. R. Flemming.

MR. COSTIGAN brought up recently before the Canadian Parliament another gas inspection amendment act. The bill as at first proposed called for an inspection of gas meters every 5 years; but he explained that he had decided instead of taking this means of increasing the revenue to increase the fees and leave the time of inspection as at present. He asserted that the deficiency in the revenue was about \$30,000. Mr. Jones advised Mr. Costigan to leave the matter alone, as there was a surplus in the treasury, and economy, which did not seem to be a marked virtue in the Department, might be practiced as a means of equalizing revenue and expenditure. Mr. Mitchell indorsed Mr. Jones' view on the ground that this would simply mean a tax upon consumers. As the 5 years' inspection system was to be continued, a mere increase in fees would not lead to an improvement in the accuracy of meters. Means, he thought, should be taken to compel the gas companies that made great dividends on watered stock to supply better gas. Mr. Lister denied that the gas companies in the smaller towns made other than fair dividends, and as this bill seemed a means of harassing the companies, he also advocated leaving the bill over. It was, however, not only read a second time, but was also put through its final stages.

TREASURER RICHARDSON, of the North Adams (Mass.) Gas Company, informs us that he is just completing the new electric annex to the Company's possessions, the buildings for which have been erected close to the generating house of the gas plant. The electric equipment comprises three 45 arc light machines and one 500-light alternating incandescent machine, all of the Thomson-Houston type. A 150-horse power Hazleton boiler is to furnish the power, and the apparatus has been most carefully placed. On May 5th the Company was awarded a contract for the public lighting of North Adams for a period of 3 years, on the basis of 70 arcs, to be paid for at the rate of 30 cents each per night, the lights to burn every night and all night. In the meantime we might remark that Treasurer Richardson does not intend to push electric lighting at the expense of his gas sendout, which continues to increase in gratifying percentage. This leads us to say that Treasurer Richardson is to be congratulated over the fact that the gas sendout in North Adams this year will not be less than 22 millions cubic feet, which is just 5½ times more than the quantity sent out in 1880. The selling rates, also, have been decreased from \$3, in 1880, to \$1.65 to \$1.85 at the present time. The distributing system of the Gas Company will be increased this season by the placing of 1½ miles of 6 and 10-inch pipes.

THE visiting gas man to this city who will have occasion to hunt up the local headquarters of the Goodwin Gas Stove and Meter Company, must bear in mind that Manager Edwards has removed himself and his shingle from 142 Chambers street to No. 113 same street.

WE are indebted to "Observer" for the following, which is from the Manchester *Mirror and American*, of the 10th inst.: "Manchester has been congratulating herself for several months that among all the manufacturing and industrial centers of the country she alone had been spared by the professional agitator and his inevitable accompanist, the prolonged strike. The fond delusion that on account of previous exemption she would escape from any future labor trouble was rudely shattered early this afternoon by the announcement, which spread with the utmost rapidity, that the employees of the Peoples gas works had gone out on a strike. The affair, as is natural in such cases, was grossly exaggerated, and from rumors flying about one would have been led to

believe that the whole of South Manchester had knocked off work. Investigation soon revealed the true condition of things, and although matters at the works are bad enough this afternoon, the state of affairs is much less ominous than was at first given out, and owing to the energetic efforts of Agent W. G. Africa the trouble promises to be tided over with but little, if any, inconvenience to the general public. The history of the strike is as follows: For some time there has been a growing feeling of discontent among the employees of the works over the wages paid by the Company. The men, so one of them informed the newspaper man that investigated the subject, had to work 13 hours per day, and as their duties were both of an arduous and confining nature, it told on their systems to a remarkable extent. Add to this the fact that a portion of their labors had to be performed in the night and a part in the day, practically spoiling the entire 24 hours, the informant stated that the men feel they have a grievance and one that could only be remedied by the addition of at least \$1.75 per week to their pay, and they had accordingly requested Mr. Africa to raise their wages from \$2 to \$2.25 a day. There appears to be some discrepancy about the time set for this raise to go into effect between the statements of the men and that of the Agent; but in any event matters were brought to a head at noon of to-day, by 26 of the employees of the works banking their fires and leaving the establishment in South Manchester to itself. The entire force on duty, with the exception of a few yard hands, are included in the ranks of the strikers, and hence, while their numbers may be small, their importance as a factor in furnishing Manchester's illuminating vapor makes the strike as formidable as many in which larger bands of breadwinners have an interest. Mr. Africa was seen with reference to the situation, and expressed himself in forcible terms as to the attitude of the Company. 'There will be no surrender,' said he; 'not even a compromise. We raised the pay of these employees, when the Peoples Company took charge of the plant, from \$1.75 to \$2, and that is all that we shall pay. We can get men enough to work for these wages that are competent to fill the position.' Mr. Africa further asserted, in reply to inquiries, that the men had applied to him yesterday for the proposed increase, and that on his refusal to grant the raise they had all given a two weeks' notice, which they abruptly terminated this noon, as seen above. With reference to the supply of gas now on hand, Mr. Africa stated that the daily consumption in the city amounted to 240,000 cubic feet, and that the stored supply could be made to last 3 days. He had also at the works at the South End a water gas plant, on the use of which injunction proceedings are now pending. He has telegraphed to Philadelphia and got this injunction raised temporarily, and if he cannot secure men enough to run the coal gas plant within the necessary 3 days, he will put his water gas apparatus into action and furnish the city with gas of that sort until the present difficulty is abated. One man with 2 helpers can, in one-half day, make gas enough to last the public a whole day, so that there does not appear to be much danger of this supply giving out. The above is the situation, with both sides standing firm, at the hour of going to press."

THE bonds of the Grand Forks (N. Dak.) Gas Company have been purchased by Messrs. E. H. Rollins & Sons. The price paid was at the rate of 80 per cent.

THE site for the new gas plant at Florence, Ala., has been selected. It is quite close to the local depot of the Louisville and Nashville Railroad.

THE Central Gas Improvement Company, to manufacture and distribute gas and electricity for lighting and other purposes, has been organized in Chicago by Messrs. Calvin Dickey, G. M. Trowbridge and J. O. Noris. It is capitalized in \$100,000.

GENERAL MANAGER McMILLAN, of the La Crosse (Wis.) Gas Company, is meeting with great success in his plan of introducing gas stoves, large numbers of which are now in use in his city. Being a believer in the efficacy of printer's ink, he has availed himself largely of the columns of the local papers for the purpose of displaying the different styles of cooking and heating stoves, hot water heaters, etc. For instance, half of the front page of the *Republican and Leader* has for some time been devoted to a handsomely illustrated advertisement, in which nine well arranged cuts display as many different styles of cooking and heating devices. Mr. McMillan's plan of booming the stove trade is so unique that we herewith give a summary of it. Stoves to the number of 100 will be virtually given away on the following basis: The purchaser selects the style of stove desired, when the Company will set it in place and properly connect it with gas. The stove will be billed at an agreed-on price, and the connections will be charged for at cost. As soon as the bill is paid the gas will be turned on, whereupon the stove

becomes the property of the consumer. Gas may then be used for any purpose without charge until the quantity so consumed, at \$2 per 1,000 cubic feet, will equal in value the amount advanced for stove and connections, after which bills for gas will be made out at \$1.50 per 1,000, and collected monthly in the usual manner. Surely, that is a liberal proposition.

MESSRS. GEORGE A. BROOKS AND HENRY MCGURRIN have laid before the Council of Norfolk, Neb., the following proposition, which is favorably viewed by the authorities: The contractor to expend \$65,000 in the construction of a gas plant, if the city will agree to contract to take gas for 25 public lamps the first year, 50 the second, 75 the third, and 100 the fourth and fifth years after the completion of the plant.

THE officers of the Roanoke (Va.) Gas and Water Company are: President, F. J. Kimbell; Secretary and Treasurer, H. E. Gerhard; Manager, J. C. Rawn.

MESSRS. W. Z. LARNED, C. A. Du Vivier, W. H. De Forest, George Manley, and Jonathan Bonnel, have given notice as incorporators of the Summit (N. J.) Gas Light Company, the enabling act for which was passed by the Legislature in 1873, that subscription books have been opened, and that subscriptions for the shares will be received to-day at the office of Mr. A. L. De Coster, township of Summit. It is understood that the majority of the stock will be taken by the proprietors of the Citizens Gas Light Company, of Newark, under whose auspices the new plant will be constructed.

Ingenious Expedient in Hydraulic Engineering.

F. S. Pecke, a civil engineer at Watertown, N. Y., lately accomplished in a very simple, cheap and expeditious way what is usually a difficult and expensive operation—the laying of a long line of pipe in deep water. He had occasion to lay nearly 1,000 feet of suction pipe at Rouse's Point. The water was needed for manufacturing purposes, and as it was found that water near the shore was more or less roily and impure, it was necessary to have the inlet a considerable distance out into the lake. He purchased for the purpose a steel pressure pipe of 8-inch diameter, manufactured by the Spiral Weld Tube Company, at East Orange, N. J., and used for couplings cast iron flanges, weighing, with bolts and gaskets, about 65 pounds to the pair. Plugging the end of the first length he pushed it out on the surface of Lake Champlain and connected the second length; pushing this out in turn until the whole line was coupled. It then presented the unusual spectacle of a line of 8 inch pressure pipe, nearly 1,000 feet long, floating with a displacement of only 3½ inches of its diameter. When the requisite length had been connected, the line was towed to position, the plug at the end removed, and the pipe sank easily in 16½ feet of water, without breaking a joint or receiving any injury. No buoys or floats were used in the operation, and no apparatus of any kind. The pipe is now in use as the suction of a steam pump, and gives perfect satisfaction. Work of this kind usually involves the use of expensive and troublesome flexible joints, and Mr. Pecke's ingenious expedient is worthy of record.

Useful Memoranda and Information for Engineers.

Loss of Water by Waste.—Water leaking through a hole just large enough to pass a needle through during 24 hours at a 14-pound pressure would be sufficient to supply a house for the day. The waste through a ¼-inch pipe under the same conditions would be 1,140 gallons.

An experienced inspector says: The most common defects to be found about the engine come from improper working or regulation by the governor, as the journals and bearings of the governor are quickly worn out if not looked after. The governor should be regularly cleaned, washed off and well lubricated. Engineers often think that their pistons and valves are not working to the best advantage, when the fault is really with the governor. Sometimes pistons leak, an effect of unequal and excessive wear. Belts being too tight cause a deal of trouble, a little sag being a good thing for bearings, as they very often get hot because the belts draw too tight.

As to boilers, laminated plates over furnace and bridge wall cause endless trouble, complaints from this outnumbering all others. The next thing to demand notice is deposit, which 90 per cent. of boilers are subject to. This causes bagging, burnt plates, opened seams and rivet checks.

Another bad fault comes from having feed and blow of the boilers at the front end. This allows the back end to become covered with sedi-

ment due to poor circulation. This should never be so. There should always be some means by which the boilers can be thoroughly cleaned and inspected. The man-hole plate in the front head is an excellent thing.

Another great fault in construction is not leaving room enough to clean boilers. Where there is any trouble or labor in getting at the parts the engineer does not give the boiler the attention it requires, and will not clean any more than is actually necessary, but where parts are easily accessible, and there is no trouble in keeping the same in good condition, the engineer will take pride in this part of his work.

Circular bridge walls should be condemned, for the reason that they are of no use and do not add to the combustion. As the fire is perfectly level—the bridge wall should also be level—that part of the shell directly over the bridge wall can be readily examined by the engineer or inspector at any time.

Steam gauge pipes should also have stop-cocks and blow-off cocks, so that the sediment and dirt can be blown out of the gauge pipes, the gauge taken down, tested and replaced while there is steam on the boiler.

Many boilers are injured by having fire lines too high—that is, above the gauge cocks; this will cause cracks, lamination and checks. The metal should not be exposed to fire where there is no water on the opposite side.

After the engineer gets the engine working well and in good order he should not tinker with it, but let him put his screw wrench on the shelf and not take it down until it is actually necessary.

Correspondence

[The JOURNAL is not responsible for the opinions expressed by correspondents.]

Gas Companies Should Control the Introduction of Gas Stoves.

CHICAGO, ILLS., May 13, 1890.

To the Editor AMERICAN GAS LIGHT JOURNAL:

In answer to numerous inquiries and letters asking my views regarding the above proposition, I thought it best to briefly submit through your JOURNAL, not only my own opinion but such information as I have gathered from gas companies and the fraternity at large, offering the same for what it may be worth. In the past few years, in the way of business, I have visited nearly every gas company in the country, and have done considerable missionary work in the gas stove field by persuading companies to buy out the stock of stoves from local dealers and operate themselves, and I have yet to learn of a single instance where the company failed to make the system a success. I give you a few reasons why gas companies should manage the stove trade.

1st. It is the gas company's interest to increase the day consumption of their product. That means increased profits and larger dividends, as well as the regular and economical working of apparatus, lessening cost of production, wear and tear, repairs, etc.

2d. For a gas stove to work successfully it should be properly connected to the right sized pipes, and necessary instructions imparted how to use it. Adjust the burner to economize the gas and have perfect combustion, and other minor points adequate to satisfy the purchaser. All gas stoves and ranges must be looked after when complaints are made, and it is imperative that they be kept clean. None are better qualified to attend to these details than employees of gas companies, who usually are experts, and have all the facilities. It should be made a part of their duties.

3d. Many companies in view of these considerations are offering very liberal inducements to encourage the consumption of gas as fuel by granting a reduced rate, selling at wholesale price, when used in large quantities; also by selling gas stoves at cost prices, piping them with a separate meter attached free of charge. In some cities the company manufacture their own stoves and rent them out at a low rental by the month. Some operate a stove store detached from their business, and, as before stated, these methods have invariably proven successful. Some recent experience in introducing hotel ranges on a large scale has forcibly impressed the necessity of having expert gas men to see to having stoves and ranges properly set up, kept clean, and educate the novice how to operate them.

The consumer may soon, when that happy millenium arrives, come to the gas office with smiles, and instead of imprecations shower blessings on the gas people as public benefactors, paying his increased gas bill without a murmur; and, of course, we as manufacturers of gas stoves cannot help from cheerfully joining with the public and sing a hosanna of praise to the gas fraternity. Very truly yours, S. S. STRATTON.



A. M. CALLENDER & CO.,
PROPRIETORS.

EDITOR—**Jos. R. Thomas, C.E.**
ASST. EDITOR—**T. J. Cunningham.**
MANAGER—**C. E. Sanderson.**

PUBLISHED ON EACH MONDAY OF THE YEAR AT
No. 42 Pine Street, New York.

This is a recognized official organ of
LIGHT, HEAT, STEAM, WATER SUPPLY,
VENTILATION, SANITARY IMPROVEMENT,
AND GENERAL SCIENCE

TERMS:

SUBSCRIPTION—Three Dollars per annum, in advance. Single copies, 10 cents.

AGENTS.

NEW YORK.—AMERICAN NEWS Co., 39 and 41 Chambers Street.
PHILADELPHIA.—PRATT & Co., Corner Ninth and Arch Streets.
Germany.—B. WESTERMANN & Co., of New York.

MONDAY, MAY 19, 1890.

Gas Stocks.

Quotations by **Geo. W. Close, Broker and Dealer in Gas Stocks.**

16 WALL ST., NEW YORK CITY.

MAY 19.

All communications will receive particular attention.

The following quotations are based on the par value of \$100 per share.

	Capital.	Par.	Bid	Asked
Consolidated.....	\$35,430,000	100	105 ³ / ₄	—
Central.....	500,000	50	85	95
“ Scrip.....	220,000	—	95	100
Equitable.....	4,000,000	100	122 ¹ / ₂	123
“ Bonds.....	1,000,000	—	113	115
Harlem, Bonds.....	170,000	—	—	—
Metropolitan, Bonds....	658,000	—	115	120
Mutual.....	3,500,000	100	115	118
“ Bonds.....	1,500,000	—	100	102
Municipal, Bonds.....	750,000	—	—	—
Northern.....	—	50	—	—
“ Bonds.....	150,000	—	—	100
Standard Gas Co —				
Common Stock.....	5,000,000	100	—	45
Preferred.....	5,000,000	100	84	87
Yonkers.....	—	50	112	—
Richmond Co., S. I.	346,000	50	—	—
“ Bonds.....	20,000	—	—	—
Gas Co's of Brooklyn.				
Brooklyn.....	2,000,000	25	114	117
Citizens.....	1,200,000	20	75	—
“ S. F. Bonds..	320,000	1000	100	103
Fulton Municipal.....	3,000,000	100	127	130
“ Bonds....	300,000	100	105	—
Peoples.....	1,000,000	10	86	88
“ Bonds (5's).....	368,000	—	100	—
“ “ (6's).....	94,000	—	100	—
Metropolitan.....	1,000,000	100	102	—
Nassau.....	1,000,000	25	120	—
“ C'tfs.....	700,000	1000	100	102
Williamsburgh.....	1,000,000	50	125	—
“ Bonds....	1,000,000	—	110	112

Out of Town Gas Companies.

Boston United Gas Co. —				
1st Series S.F. Trust	7,000,000	1000	93	93 ¹ / ₂
2d “ “ “	3,000,000	1000	71	72
Bay State Gas Co. —				
Stock.....	5,000,000	50	83	84
Income Bonds.....	2,000,000	1000	—	—
Buffalo Mutual, N. Y....	750,000	100	90	95
“ Bonds...	200,000	1000	95	100
Citizens, Newark.....	1,000,000	50	155	160
“ “ Bonds.	45,000	—	—	—
Chicago Gas Trust.....	25,000,000	100	63 ¹ / ₄	—
Chicago Gas Light. & Coke Co. —				
G'd Gold Bonds	7,650,000	1000	97 ¹ / ₂	98 ¹ / ₄
Equitable Gas & Fuel Co., Chicago, Bonds	2,000,000	1000	94 ¹ / ₈	95 ¹ / ₂
People's Gas and Coke Co., Chicago—				
1st Mortgage.....	2,100,000	1000	—	100
2d “	2,500,000	1000	96	100
Consumers Gas Light Co., Jersey City.....				
Bonds.....	600,000	1000	80	—
Cincinnati G. & C. Co..	6,000,000	100	201	203
Consumers Toronto....	1,000,000	50	190	200
Central, S. F., Cal.....	—	—	80	90
Capital, Sacramento, Cal	—	—	58	—
Consolidated, Balt.....	11,000,000	100	52	52 ¹ / ₄
“ Bonds.....	6,400,000	—	107	107 ¹ / ₂
Citizens Gas Lt. Co., Rochester, N. Y.....				
Bonds.....	500,000	—	75	90
Hartford, Conn.....	750,000	25	102	108
Jersey City.....	750,000	20	170	175
Laclede Gas Light Co., St. Louis, Mo.—				
Common Stock....	7,500,000	100	27 ¹ / ₄	—
Preferred “	2,500,000	100	64	70
Bonds.....	9,034,400	1000	87	88

Advertisers Index.

GAS ENGINEERS.

	Page
Jos. R. Thomas, New York City	717
Wm. Henry White, New York City	723
Wm. Mooney, New York City.....	717
William Gardner, Pittsburgh, Pa.....	717
Fred. Bredel, N. Y. City.....	719

GAS WORKS APPARATUS AND CONSTRUCTION.

James R. Floyd & Sons, New York City	723
Continental Iron Works, Greenpoint, L. I	723
Deily & Fowler, Phila., Pa	723
Kerr Murray Mfg. Co., Fort Wayne, Ind.....	720
Stacey Mfg. Co., Cincinnati, Ohio.....	723
Bartlett, Hayward & Co., Baltimore, Md.....	721
Morris, Tasker & Co., Limited, Phila., Pa.....	721
Davis & Farnum Mfg. Co., Waltham, Mass.....	720
R. D. Wood & Co., Phila., Pa.....	722
Bouton Foundry Co., Chicago, Ills.....	723
Smth & Sayre Manufacturing Co., New York City.....	722
Fred. Bredel, N. Y. City.....	719
United Gas Improvement Co., Phila., Pa.....	713
National Gas Light and Fuel Co., Chicago, Ills.....	710
Simpkin & Hillyer, Richmond, Va.	707

GAS AND WATER PIPES.

Gloucester Iron Works, Phila., Pa.....	717
Mellert Foundry and Machine Co., Reading, Pa. (John Fox, Selling Agent, N. Y.).....	717
Ohio Pipe Co., Columbus, Ohio.....	717
M. J. Drummond, New York City.....	717
R. D. Wood & Co., Phila., Pa.....	722
Warren Foundry & Machine Co., New York City.....	717
Donaldson Iron Co., Emaus, Pa	717
Dennis Long & Company, Louisville, Ky.....	717

PROCESSES.

National Gas Light and Fuel Co., Chicago, Ills.....	710
Bartlett, Hayward & Co., Baltimore, Md.....	721
Wm. Henry White, N. Y. City.....	723
United Gas Improvement Co., Phila., Pa.....	713
The Fuel Gas and Light Improvement Co., N. Y. City.....	708

INCLINED RETORTS.

Laclede Fire Brick Manuf'g Co., St. Louis, Mo.....	708
--	-----

GASHOLDER TANKS.

W. C. Whyte, New York City.....	710
J. P. Whittier, Brooklyn, N. Y.....	715

GASHOLDER PAINT.

The Government Waterproof Paint Co., Boston, Mass.....	707
--	-----

RETORTS AND FIREBRICK.

J. H. Gautier & Co., Jersey City, N. J....	718
B. Krelscher & Sons, New York City.....	718
Adam Weher, New York City.....	718
Laclede Fire Brick Manuf'g Co., St. Louis, Mo....	718
Brooklyn Retort and Fire Brick Works, Brooklyn, N. Y	718
Borgner & O'Brien, Phila., Pa.....	718
James Gardner, Jr., Pittsburgh, Pa.....	718
Henry Maurer & Son, New York city.....	719
Chicago Retort and Fire Brick Co., Chicago, Ills.....	718
Baltimore Retort and Fire Brick Co., Baltimore.....	718
Oakhill Gas Retort and Fire Brick Co., St. Louis, Mo.....	718
Boston Fire Brick Works, Boston, Mass.....	718

SCRUBBERS AND CONDENSERS.

G. Shepard Page, New York City.....	712
R. D. Wood & Co., Phila., Pa.....	722

REGENERATIVE FURNACES.

Bartlett, Hayward & Co., Baltimore, Md.....	721
Fred. Bredel, New York City	719
Chicago Retort and Firebrick Co., Chicago, Ills.....	718
J. H. Gautier & Co., Jersey City, N. J.....	719

GAS GOVERNORS.

Connelly & Co., New York City.....	715
Fred. Bredel, N. Y. City.....	719
Friedrich Lux, London, England.....	707

SELF-SEALING MOUTHPIECE DOORS.

Smth & Sayre Mfg. Co., New York City.....	722
---	-----

TAR AND CARBONIC ACID EXTRACTOR.

Geo. Shepard Page, N. Y. City.....	676
------------------------------------	-----

CEMENTS.

C. L. Gerould & Co., Brooklyn, N. Y.....	718
--	-----

GAS ENRICHERS.

Standard Oil Co., Cleveland, Ohio	724
---	-----

GAS METERS.

John J. Griffin & Co., Phila., Pa	726
American Meter Co., New York and Philadelphia.....	727
The Goodwin Gas Stove and Meter Co., Philadelphia, Pa....	727
Helme & McIlhenny, Phila., Pa.....	727
D. McDonald & Co., Albany, N. Y.....	727
Nathaniel Tufts, Boston, Mass.....	726
Maryland Meter and Manufacturing Co., Baltimore, Md ..	672
Bell & Jones, Philadelphia, Pa.....	726
Harris Bros. & Co., Philadelphia, Pa.....	726

EXHAUSTERS.

The P. H. & F. M. Roots Co., Connersville, Ind	714
Smth & Sayre Manufacturing Co., New York City.....	722
Wilhrabam Bros., Philadelphia, Pa.....	715
Connelly & Co., New York City.....	715

GAS COALS.

Penn Gas Coal Co., Phila., Pa	725
Perkins & Co., New York City	724
Newburgh Orrel Coal Co., Baltimore Md.....	725
Despard Coal Co., Baltimore, Md	725
Chesapeake and Ohio R. R. Coal Agency, N. Y. City.....	725
Westmoreland Coal Company, Phila., Pa	725
J. & W. Wood, New York City	724

CANNEL COALS.

Perkins & Co., New York City.....	724
J. & W. Wood, New York City.....	724

VALVES.

Ludlow Valve Manufacturing Co., Troy, N. Y.....	716
John McLean, New York City	716
Chapman Valve Manufacturing Co., Boston, Mass.....	716
R. D. Wood & Co., Phila., Pa.....	722
The P. H. & F. M. Roots Co., Connersville, Ind.....	714

GAS ENGINES.

Schleicher, Schumm & Co., Phila., Pa.....	728
Clerk Gas Engine Co., Phila., Pa....	716
Van Duzen Gas Engine Co., Cincinnati, Ohio.....	716

ENGINES AND BOILERS.

Jarvis Engineering Co., Boston, Mass.....	715
Ball Engine Co., Erie, Pa.....	707

STEAM PUMPS.

Van Duzen & Tift, Cincinnati, Ohio..... 707

GAS LAMPS.

Welsbach Incandescent Gas Light Co., Phila., Pa..... 709
The Siemens-Lungren Company, Philadelphia, Pa..... 709
Fiske, Coleman & Company, Boston, Mass..... 718

PURIFIER SCREENS.

John Cabot, New York City... 716
Bartlett, Hayward & Co., Baltimore, Md..... 716

GAS STOVES.

American Meter Co., New York and Philadelphia..... 711
The Goodwin Gas Stove and Meter Co., Phila. Pa 692
George M. Clark & Company, Chicago, Ills..... 709
D. McDonald & Co., Albany, N. Y..... 727
Maryland Meter and Manufacturing Co., Baltimore, Md..... 672
Bell & Jones, Philadelphia, Pa..... 726
Chicago Gas Stove Company, Chicago, Ills..... 708

STREET LAMPS.

J. G. Miner, Morrisania, New York City..... 707
Bartlett Street Lamp Man'fg Co., New York City..... 707

BURNERS.

C. A. Gefrorer, Phila., Pa..... 724
H. W. Rappleye, Philadelphia, Pa..... 368

STEAM BLOWER FOR BURNING BREESE.

H. E. Parson, New York City. 716

PURIFYING MATERIAL.

Connelly & Co., New York City..... 715
Friedrich Lux, London, England..... 707
Edgewater Lime Works, Edgewater, N. J..... 708

COKE CRUSHER.

C. M. Keller, Columbus, Ind..... 725

ELECTRICAL APPARATUS.

Wm. Henry White, N. Y. City. 723

BOOKS, ETC.

Gerould's System Gas Bookkeeping..... 707
1 90. Directory. 1890 715
King's Treatise 717
Scientific Books 719
Management of Small Gas Works..... 716
Gas vs. Electricity 672
Practical Electric Lighting 715
Electric Light Primer... 715
American Gas Engineer and Superintendents' Handbook... 725
Digest of Gas Law..... 671
Fuel and its Applications 671
Newbigging's Handbook 719

WANTED,

By an experienced man,

Situation as Inspector.

Thoroughly competent in all branches of distribution work.
780-2 Address INSPECTOR, care this Office.

Position Wanted

As Superintendent or Assistant of a Gas Works,
By a man who can give the best of references. Thoroughly
understands the manufacture and distribution of gas and the
construction of works. Address
779-5 "M.," care this Journal.

POSITION WANTED

As Superintendent of Gas Works.

Eleven years' experience in the manufacture of coal gas. Best
of references given.
W. L. CARVER, Supt.,
778-8 Cartbage, Mo.

FOR SALE,

The Ironwork for Twelve Benches of 6's, vis.:
Cast Iron Hydranic Main.
7-inch Dip-Pipes, Stand-Pipes, and Bridge-
Pipes, complete.
Floyd Mouthpieces and Self-Sealing Lids, 15x26 in.
Lids and Mouthpieces only in use over a year. Will be sold
cheap.
ISAAC C. BAXTER,
772-tf Detroit (Mich.) Gas Lt. Co.

WANTED,

By a New England Gas Company,

**A Man to Repair Meters, take
Meter Readings, etc.**

776-5 Address "H. R.," care this Journal.

**GEROULD'S
System Gas Bookkeeping.**

Approved and adopted by many of the prom-
inent Gas Engineers of the Country.

Sample Sheets and Price-List furnished free on application to

L. P. GEROULD, - - Mendota, Ill.

FRIEDRICH LUX,

Ludwigshafen am Rhein and London.

**Lux Mass,
GAS GOVERNORS,
Gas Balance.**

Simpkin & Hillyer

RICHMOND, VA.

MANUFACTURERS OF

Gas Works Apparatus

BENCH CASTINGS, CONDENSERS,

Scrubbers, Purifiers, Dry Center Seals,

FOUR-WAY VALVES, GAS VALVES,

SULPHATE OF AMMONIA APPARATUS,
TANKS, ENGINES, BOILERS,
PUMPS, ETC., ETC.

Plans, Specifications and Estimates furnished for new works,
or alteration of old works. Correspondence solicited. Works
Newport News, Va

Bartlett Street Lamp Mfg. Co.

MANUFACTURERS OF

Globe Lamps,

FOR

Streets, Parks, Public
Buildings, Railroad
Stations, etc.

LAMP POSTS

A Specialty.



Office and Salesroom,

40 & 42 COLLEGE PLACE, - - N. Y. CITY.

Gas Companies and others intending to erect Lamps
and Posts will do well to communicate with us.

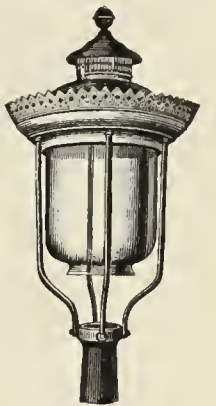
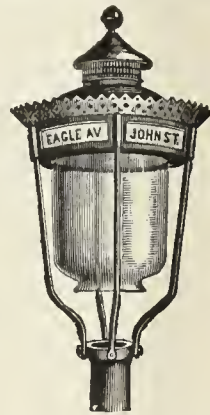

**The Miner Street Lamps.
Jacob G. Miner,**

No. 823 Eagle Ave., New York, N. Y.

**VAN DUZEN'S
STEAMJET PUMP**

For Water Supply Tanks.
For Fire Pump on Yard or Switch Engines.
For Round House General Work.
For Draining Ponds, Pits, Coffin Dams, etc.
10 Sizes. \$7 to \$75. Thousands in use.
Write for Descriptive Book to VAN DUZEN
& TIFT, 106 E. Second St., CINCINNATI, O.

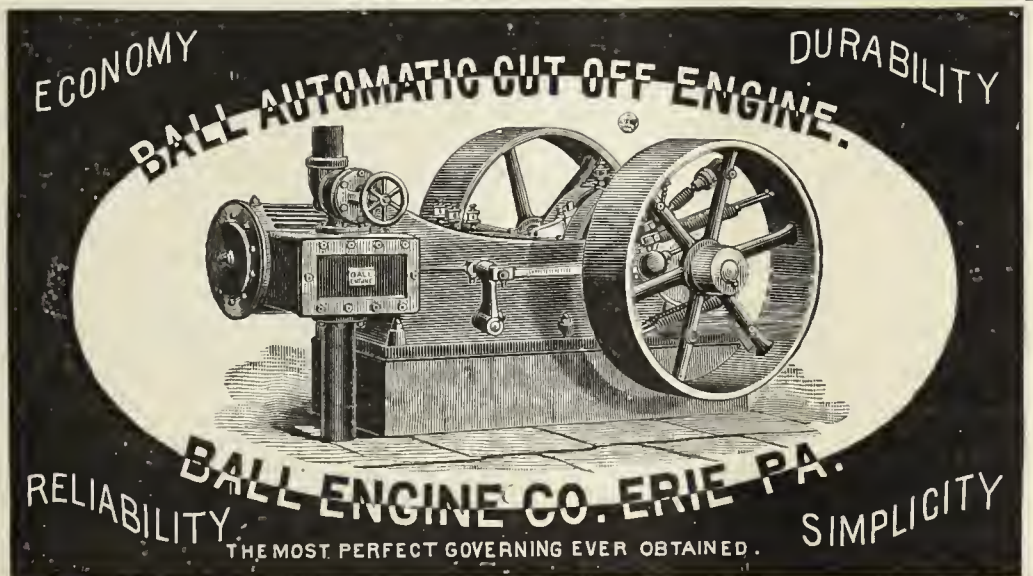

GASHOLDER PAINT.

Use Only

THE GOVERNMENT WATERPROOF PAINT.

Proof against Ammonia, and Absolutely Waterproof. Send for Prices and Particulars.
THE GOVERNMENT WATERPROOF PAINT CO., 122 Milk Street, Boston, Mass.

F. D. HARMON, PRES.

CHAS. C. ALLEN, SEC. AND TREAS.

P. W. MACKENZIE, CHIEF ENGR.

THE FUEL GAS AND LIGHT IMPROVEMENT CO.

OF AMERICA.

Owner of the Mackenzie Patents of Dec. 31, 1889, and later dates.

For the United States, England, Russia, France, Germany, Austria, and Canada,

No. 32 Park Place, New York City.

This SYSTEM is an ABSOLUTELY NEW DEPARTURE IN THE MANUFACTURE OF FUEL AND ILLUMINATING GAS. The COST OF GAS IN THE HOLDER by our System is at least THIRTY PER CENT. LESS than that made by any other process of the day. The Gas contains neither SULPHUR nor other impurities, nor is there any resultant LAMPBLACK OR TAR RESIDUUM. The Gas is manufactured WHOLLY from LIQUID HYDROCARBONS, such as Lima, Penn. Crude, and Fuel Oils, Naphtha, etc. Neither PERISHABLE PIPES nor other RETORTS, NOR THEIR EQUIVALENTS, are used.

Neither COAL, COKE, nor any other HARD CARBONS enter into the manufacture or composition of the Gas, thereby requiring LESS LABOR THAN ANY OTHER METHOD. The APPARATUS is extremely SIMPLE, SUBSTANTIAL, and DURABLE.

Works under our system may be CONTINUOUS or ALTERNATING. If alternating, the Nitrogen present will be less than 4½ per cent. If continuous, the limited amount of Nitrogen present is neutralized by Carbon.

One gallon of Lima oil by our process EQUALS ALL THE COAL required for making 1,000 feet of carbureted Water Gas.

LACLEDE FIRE BRICK MANUFACTURING COMPANY,

ST. LOUIS, MO.

Exclusive Agents in the United States

FOR THE

**Coze System of
Inclined Retorts.**

**IT IS THE COMING BENCH
FOR MAKING COAL GAS.**

*It will Save from 50 to
60 per ct. in Labor.*

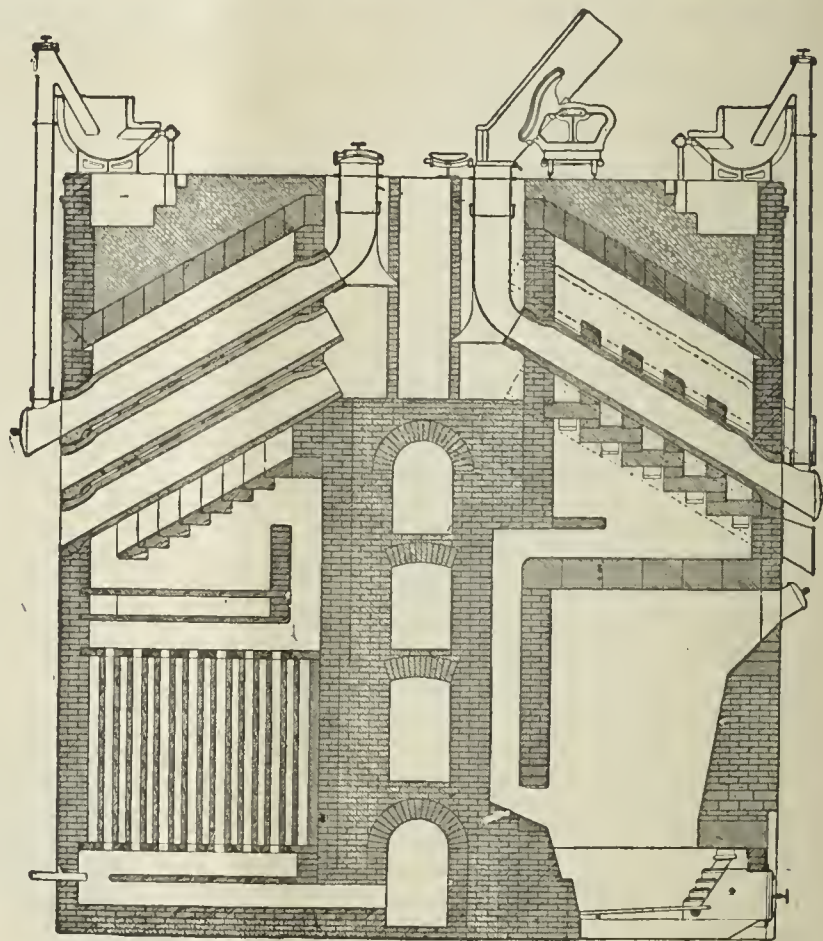
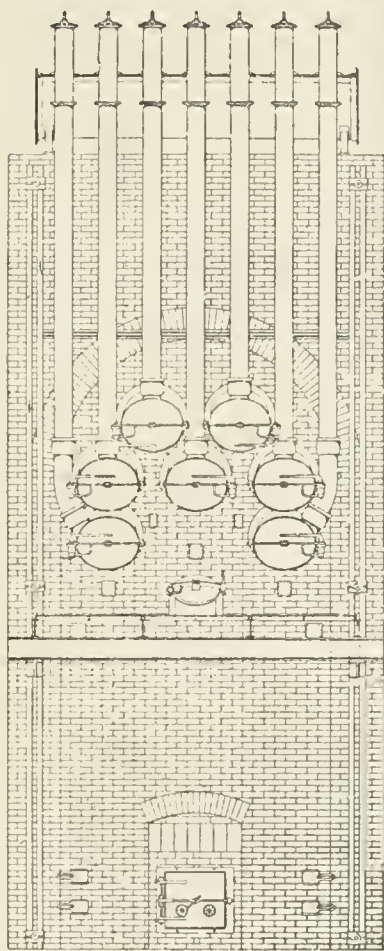

ESTIMATES AND PLANS FURNISHED BY THE

LACLEDE FIRE BRICK MFG. CO., ST. LOUIS, MO.

EDGEWATER LIME WORKS

Chas. F. McKenna, Proprietor.

SHELL LIME.

Lime by the Cargo for Gas Purification.

EDGEWATER, BERGEN CO., N. J.

Write for Testimonials and Prices.

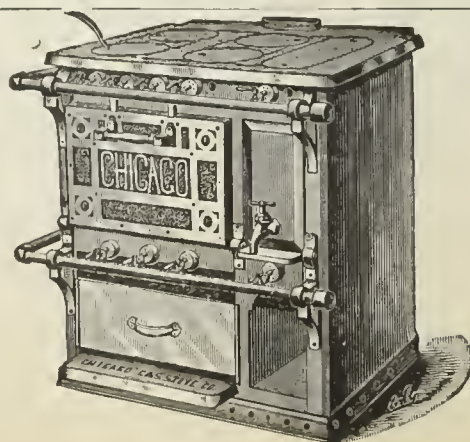

CHICAGO GAS STOVE CO.

MANUFACTURERS OF ALL KINDS OF

Gas Cooking and Heating APPLIANCES.

117-119 Lake St., CHICAGO.

Send for Catalogue.

The Gordon Portico Lamp.

A successful Competitor of the Arc Electric Light for lighting Store Fronts, Show Windows, Depots, Railway Sheds, etc., etc.

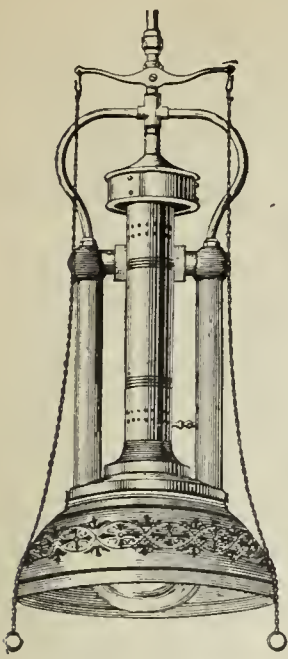

Gordon Portico Lamp.

The Gordon Street Lamp.

A Successful Competitor of the Arc Electric Light for lighting Streets, etc., etc.

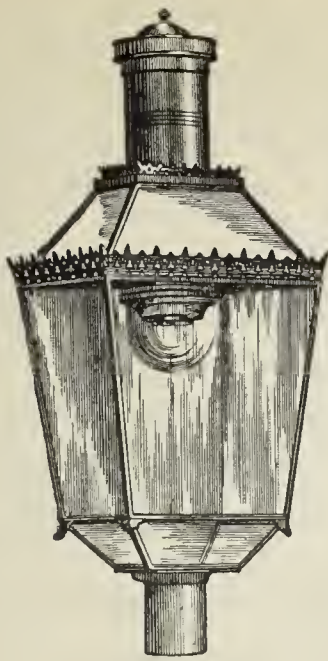

Gordon Street Lamp.

The Lungren Lamp.

A Successful Competitor of the Incandescent Electric Light for Interiors, etc. Is especially applicable for the lighting of Offices, Stores, Factories, Mills, Show Windows, Libraries, and all situations where an increased illumination is desired.

More than 25,000 Lungren Lamps are now in use. Testimonials, references, or any desired information will be cheerfully given.

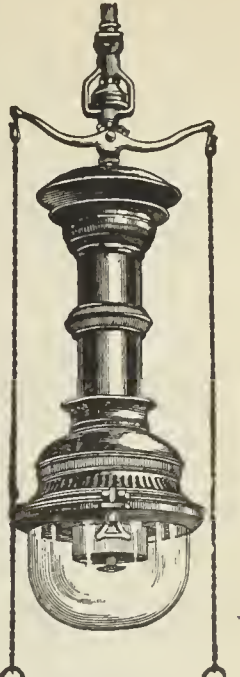

Lungren Lamp.

THE SIEMENS-LUNGREN CO., N.E. Cor. 21st St. & Washington Av., PHILADELPHIA.

WELSBACH SYSTEM OF Incandescent Gas Lighting.

OFFICE, DREXEL BUILDING, PHILA., PA.

At the Fall Session of the Board of Supervisors of Winnebago County, held at the County Court House, Oshkosh, Wis., Nov. 26, 1889, the report submitted by Mr. C. W. Cook, Chairman of the Committee on Public Buildings, recommending the use of the Welsbach Incandescent Gas Burner in the Buildings under their charge, was unanimously adopted, because of the extreme economy in the consumption of Gas and the superior character of the light obtained.

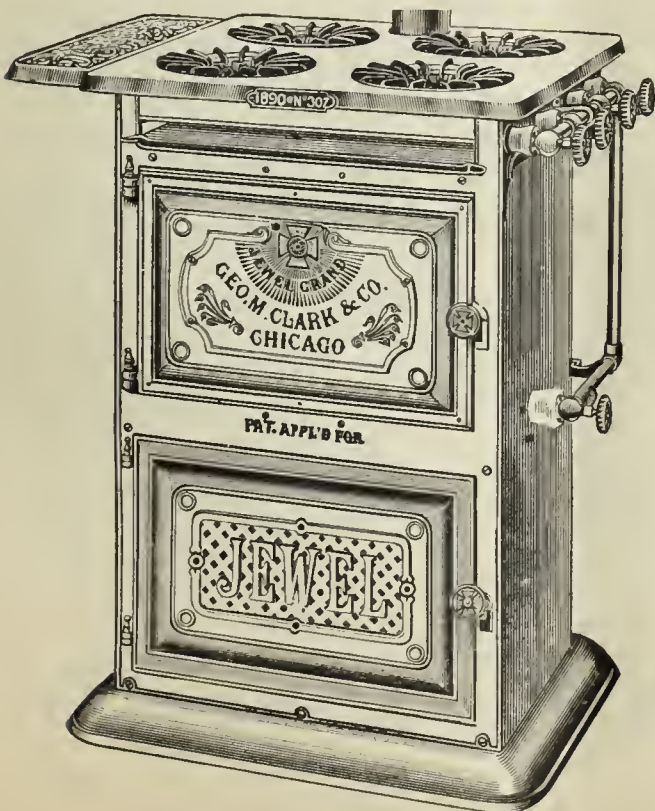

JEWEL GAS STOVES

MANUFACTURED BY

GEORGE M. CLARK & COMPANY,

Nos. 157 & 159 Superior Street, - - - Chicago, Ill.

EVERY CONCEIVABLE SIZE AND STYLE,

Ranging in Prices from \$1.50 to \$30.00.

WE USE NO GAS COCKS.

All Flames are Regulated by a Direct Needle Valve.

The JEWEL

IS THE

Only Well-Made Gas Stove on the Market.

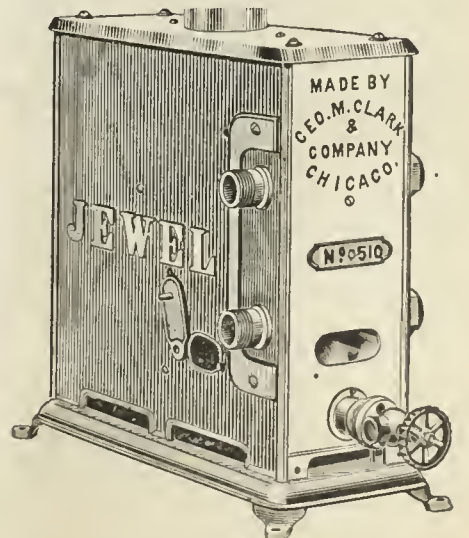

Jewel Circulating Water Heater.

Write for our 1890 Catalogue and see for yourself.

NATIONAL GAS LIGHT AND FUEL CO.,

218 La Salle Street, Chicago.

C. D. HAUK, Prest. & Gen'l Manager.

A. W. GREEN, Vice-Prest.

N. A. McCLARY, Sec. & Treas.

E. E. MORRELL, Engr.

GAS WORKS

Built, Remodeled, Leased, and Purchased.

71 Springer Cupolas have been installed in the U. S. during the past four years.

The total capacity of Springer Apparatus now in use is over 25,000,000 ft. daily.

THE SPRINCER CUPOLA SYSTEM

Has Proven Itself the most Economical and Satisfactory Method of Gas Manufacture ever brought to the attention of the Gas Fraternity.

GUARANTEED ESTIMATES of Cost of Gas Furnished on Application.

GASHOLDER TANK CONSTRUCTION, ETC.

Gas Companies and others about to erect Gasholders will find it profitable to consult W. C. Whyte, who for over 30 years has made a specialty of

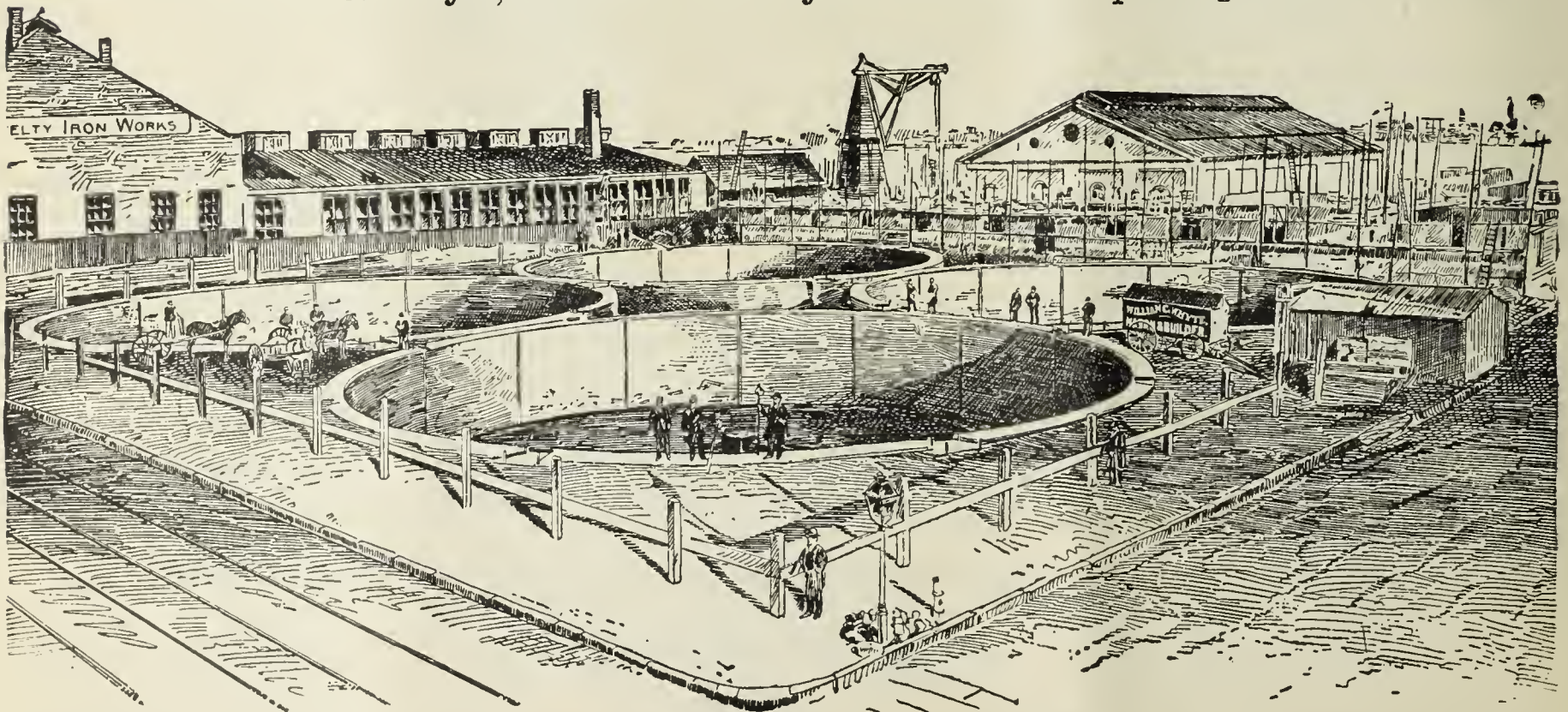

Tank Excavation and Mason Work.

Fifty Tanks now in operation show the sort of work done. Address

W. C. WHYTE. - No. 15 Cortlandt Street, N. Y. City

GAS STOVES.

GAS METERS.

GAS STOVES.

THE AMERICAN METER CO.

Established 1834.

Incorporated 1863.

MANUFACTURERS OF

Gas Meters,

STATION METERS,

METER PROVERS, PHOTOMETERS,

Pressure Gauges of all Kinds,



Standard 3 Diaphragm Dry Meter.

AND



Standard 2 Diaphragm Dry Meter.

Apparatus for Testing the Quantity and Quality of Gases.

GAS STOVES FOR HEATING AND COOKING.



Circulars and Price Lists on Application.

MANUFACTORIES,

508 to 514 West Twenty-second St., N. Y.

Arch and Twenty-second St, Phila.

Nos. 244 & 246 North Wells Street, Chicago, Ill.

AGENCIES,

No. 177 Elm Street, Cincinnati, Ohio.

No. 222 Sutter Street, San Francisco, Cal.

No. 810 North Second Street, St. Louis, Mo.

GAS STOVE SHOW ROOMS, No. 242 Sixth Avenue, New York City.

KIRKHAM, HULETT & CHANDLER, LIMITED.

PATENT "STANDARD" WASHER-SCRUBBERS
Erected and in course of construction at present date:

Capacity. Cubic feet per day.	Capacity. Cubic feet per day.	Capacity. Cubic feet per day.	Capacity. Cubic feet per day.
Altrincham..... 600,000	Dublin..... 3,000,000	LONDON—Continued.	Ober Schlesian 1,500,000
Adelaide..... 600,000	Dowlais..... 100,000	Shoreditch..... 2,500,000	Otto & Co.'s Coke Works.... 1,500,000
Aldershot..... 200,000	Douai..... 500,000	Panaras..... 1,500,000	Plymouth..... 2,000,000
Allegheny, U. S. A..... 1,000,000	Denton..... 500,000	"..... 1,500,000	Parramatta, N. S. W..... 100,000
Ashton-under-Lyne..... 1,250,000	Derby, U.S.A..... 350,000	Pimlico..... 2,000,000	Prescott..... 150,000
Amsterdam..... 1,500,000	Denver, "..... 500,000	Nine Elms..... 3,000,000	Providence, U.S.A..... 750,000
"..... 1,500,000	"..... 1,000,000	"..... 3,000,000	"..... 750,000
Annaberg..... 200,000	Dusseldorf..... 750,000	South Metropolitan Co:—	Plauen..... 300,000
Arcachon..... 100,000	"..... 500,000	Greenwich..... 3,000,000	"..... 300,000
Animal Charcoal Co..... 200,000	Dumfries..... 250,000	Woolwich..... 400,000	Portsmouth..... 2,500,000
Altoona, U.S.A..... 350,000	Dunedin, N.Z..... 400,000	Vauxhall..... 3,000,000	"..... 2,500,000
Buxton..... 250,000	Darlington..... 1,250,000	"..... 3,000,000	Pittsburgh, U.S.A..... 1,500,000
Bradford..... 1,000,000	Detroit, U.S.A..... 750,000	Lea Bridge..... 300,000	Portland, "..... 560,000
"..... 1,250,000	Edinburgh..... 1,500,000	West Ham..... 1,500,000	Pawtucket, "..... 500,000
"..... 1,250,000	"..... 2,000,000	Leeds..... 2,000,000	Quebec..... 250,000
"..... 1,250,000	Enfield..... 300,000	"..... 3,000,000	Radcliffe..... 750,000
"..... 1,000,000	Essen..... 300,000	"..... 3,000,000	Rouen..... 250,000
"..... 1,000,000	Elbing..... 150,000	"..... 3,000,000	Ramsgate..... 1,000,000
"..... 3,000,000	Falmouth..... 150,000	"..... 3,000,000	Reigate..... 200,000
Bremen..... 150,000	Frankfort..... 300,000	"..... 3,000,000	Richmond, U.S.A..... 250,000
Baltimore, U.S.A..... 1,000,000	Farnworth..... 400,000	"..... 3,000,000	Roxbury, "..... 500,000
"..... 1,000,000	Fenton..... 400,000	"..... 3,000,000	Runcorn Soap Co..... 20,000
"..... 1,000,000	Friedenshutte..... 500,000	"..... 2,000,000	Rockhampton, N. S. W..... 125,000
Balmain, N.S.W..... 125,000	Farth..... 400,000	Leominster..... 150,000	Richmond..... 1,500,000
Bishops Stortford..... 150,000	Freiburg..... 200,000	Leiden..... 560,000	Reading..... 2,000,000
Blackpool..... 400,000	Goole..... 250,000	"..... 600,000	Reichenbach..... 200,000
Brussels..... 1,250,000	Glossop..... 300,000	Liverpool..... 2,000,000	Salford..... 1,750,000
"..... 1,250,000	Guildford..... 300,000	"..... 2,000,000	"..... 1,750,000
"..... 750,000	Gloucester..... 1,250,000	"..... 2,000,000	"..... 1,750,000
"..... 1,250,000	Gera..... 300,000	"..... 2,000,000	Smethwick..... 750,000
Banbury..... 250,000	Grafton, N.S.W..... 100,000	"..... 2,000,000	Sydney, N. S. W..... 1,000,000
Birmingham..... 5,000,000	Grieg..... 300,000	"..... 3,000,000	"..... 1,000,000
Birkenhead..... 2,500,000	Georgetown, U.S.A..... 250,000	Lincoln..... 1,000,000	"..... 2,500,000
Blackburn..... 1,500,000	Gluckauf..... 200,000	"..... 600,000	"..... 50,000
Bochum..... 600,000	Heywood..... 600,000	Lowell, U. S. A..... 1,000,000	"..... 50,000
Burtonisland..... 250,000	Holywood..... 125,000	Louisville "..... 1,500,000	Sunderland..... 1,500,000
Boston, U.S.A..... 2,000,000	Huy..... 70,000	Long Eaton..... 500,000	St. Josephs, U.S.A..... 250,000
Brisbane..... 1,500,000	Harrow..... 250,000	Lilie..... 900,000	Spa..... 100,000
"..... 300,000	Harrogate..... 250,000	"..... 450,000	Sevenoaks..... 300,000
Burton-on-Trent..... 1,500,000	Halstead..... 150,000	"..... 750,000	St. Petersburg..... 2,000,000
Barcelona..... 350,000	Heilbronn..... 200,000	"..... 250,000	"..... 1,500,000
Barking..... 100,000	Havana, Cuba..... 750,000	"..... 250,000	St. Louis, U.S.A..... 2,000,000
Baerlien & Co..... 20,000	Hastings..... 1,500,000	Luckenwalde..... 330,000	"..... 2,000,000
"..... 20,000	Huddersfield..... 300,000	Liegwitz..... 300,000	"..... 1,000,000
Bombay..... 400,000	"..... 750,000	Lincoln, U. S. A..... 1,000,000	Laclede..... 1,000,000
Buffalo, U.S.A., Mutual..... 750,000	"..... 1,500,000	Lawrence "..... 500,000	Silesian Coal Co..... 600,000
"..... Citizen..... 500,000	Hof..... 200,000	Lynn "..... 300,000	San Francisco, U.S.A..... 2,000,000
Brookline, U.S.A..... 500,000	Hampton Wick..... 500,000	Lyons..... 1,500,000	"..... 2,000,000
Bergen..... 350,000	Heckmondwicke..... 500,000	Maidstone..... 1,000,000	Sheepbridge Coal Co..... 40,000
Berlin..... 1,250,000	Haverfordwest..... 100,000	Marseilles..... 1,500,000	Stettin..... 200,000
Bournemouth..... 1,000,000	Halifax, N.S..... 350,000	"..... 1,500,000	Singapore..... 300,000
Bridgeport, U.S.A..... 500,000	Hamm..... 200,000	Mons..... 500,000	Sutton..... 500,000
Brunswick..... 300,000	Halle..... 400,000	Malines..... 250,000	Tonbridge..... 150,000
Beck & Co., St. Louis..... 100,000	Heidelberg..... 300,000	Melbourne..... 1,500,000	Tiptou..... 400,000
Barmen Rittershausen..... 600,000	Hartford, U.S.A..... 1,000,000	"..... 1,500,000	Tottenham..... 1,000,000
Bexhill..... 125,000	Ilkeston..... 300,000	"..... 1,500,000	Toledo, U.S.A..... 750,000
Brooklyn, U.S.A..... 1,000,000	Inverness..... 2,000,000	"..... 1,500,000	Toronto..... 1,000,000
"..... Nassau..... 1,000,000	Ilkley..... 200,000	"..... 1,500,000	Uxbridge..... 300,000
Brunner, Mond & Co..... 400,000	Ilford..... 100,000	Manchester..... 2,500,000	Valparaiso..... 500,000
Cheltenham..... 2,000,000	Kingston-on-Hull..... 400,000	Middleton..... 400,000	West Bromwich..... 1,000,000
Cannes..... 200,000	Kidderminster..... 750,000	Manley, N. S. W..... 100,000	Willenhall..... 250,000
Croydon..... 1,500,000	Kidsgrove..... 100,000	Minneapolis, U. S. A..... 750,000	Weston super-Mare..... 500,000
Copenhagen..... 200,000	Konigberg..... 1,000,000	Magdeburg..... 300,000	Waltham..... 150,000
Cleveland..... 200,000	King's Lynn..... 300,000	Memphis, U. S. A..... 750,000	Wormwood Scrubs..... 300,000
Columbus, U.S.A..... 500,000	LONDON:—	Nottingham..... 1,250,000	Williamsburg, U.S.A..... 600,000
Cincinnati, "..... 1,500,000	The Gaslight and Coke Co.:	"..... 2,500,000	"..... 600,000
"..... "..... 1,500,000	Beckton..... 1,250,000	"..... 2,500,000	Wellington..... 150,000
Chicago..... 3,000,000	"..... 1,250,000	"..... 2,000,000	Warwick..... 300,000
"..... "..... 1,000,000	"..... 1,250,000	"..... 1,500,000	Wheeling, U.S.A..... 500,000
"..... "..... 1,000,000	"..... 1,250,000	"..... 2,000,000	Walker..... 300,000
Chemnitz..... 1,000,000	"..... 1,250,000	Newport, U.S.A..... 430,000	Westgate..... 100,000
Creve..... 1,250,000	"..... 1,250,000	Newmarket..... 150,000	Wilmington, U.S.A..... 500,000
Colonial Gas Works Co..... 100,000	"..... 1,250,000	Newark, U.S.A..... 680,000	Windsor, N. S. W..... 100,000
Cadiz..... 300,000	"..... 2,500,000	Northfleet..... 200,000	Wolverton..... 100,000
Charlottenburg..... 600,000	"..... 2,500,000	New York, U.S.A..... 2,000,000	Wellington, N. Z..... 250,000
Dudley..... 750,000	Silvertown..... 1,000,000	Nice..... 600,000	Whitchurch..... 175,000
Driffield..... 100,000	Bromley..... 2,000,000	Newcastle, N. S. W..... 200,000	Washington, U.S.A..... 2,000,000
Dukenfield..... 500,000	"..... 1,500,000	Numea, "..... 100,000	Wallasey..... 750,000
Dover..... 750,000	"..... 1,500,000	Namur..... 250,000	Weimar..... 150,000
"..... 1,000,000	"..... 1,500,000	Newark..... 350,000	Wurzen..... 200,000
Deal..... 200,000	"..... 2,000,000	Oldbury..... 500,000	Worcester, U.S.A..... 750,000
Derby..... 1,500,000	"..... 1,500,000	Otley..... 200,000	Yeaton..... 500,000
		Oswestry..... 250,000	Yeovil..... 250,000

SOLE AGENT FOR WESTERN HEMISPHERE,

GEO. SHEPARD PAGE, 69 WALL STREET, NEW YORK

THE UNITED GAS IMPROVEMENT CO.

Drexel Building,

CHESTNUT AND FIFTH STREETS,

PHILADELPHIA, PA.

OFFICERS:

WILLIAM W. GIBBS, President.

GEORGE PHILLER, Vice-President.

SAM'L T. BODINE, Gen'l Manager.

RANDAL MORGAN, Gen'l Counsel.

EDWARD C. LEE, Sec'y and Treas.

ALEX. C. HUMPHREYS, Gen'l Supt.

WALTON CLARK, Ass't Gen'l Supt.

H. H. EDGERTON, Chem. and Eng'r.

DIRECTORS:

GEORGE PHILLER,

HENRY C. GIBSON,

WILLIAM G. WARDEN,

THOMAS DOLAN,

WM. T. CARTER,

SAM'L T. BODINE.

BUILDERS, LESSEES AND PURCHASERS OF

✻ GAS WORKS. ✻

ROOTS' GAS AND BYE-PASS VALVES.

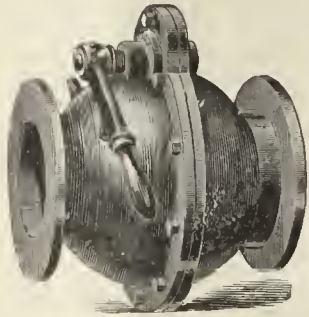

GAS VALVE

Quick Acting,
Simple,
Efficient, Durable.

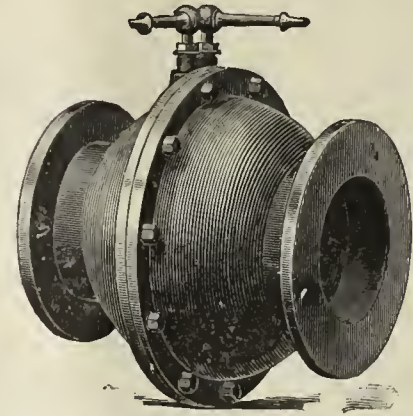

BYE-PASS VALVE.

Automatic Action
Reliable
Simple Durable.

Thousands now in use and giving perfect satisfaction. Write for Catalogue and Prices.

ROOTS' NEW GAS EXHAUSTER.

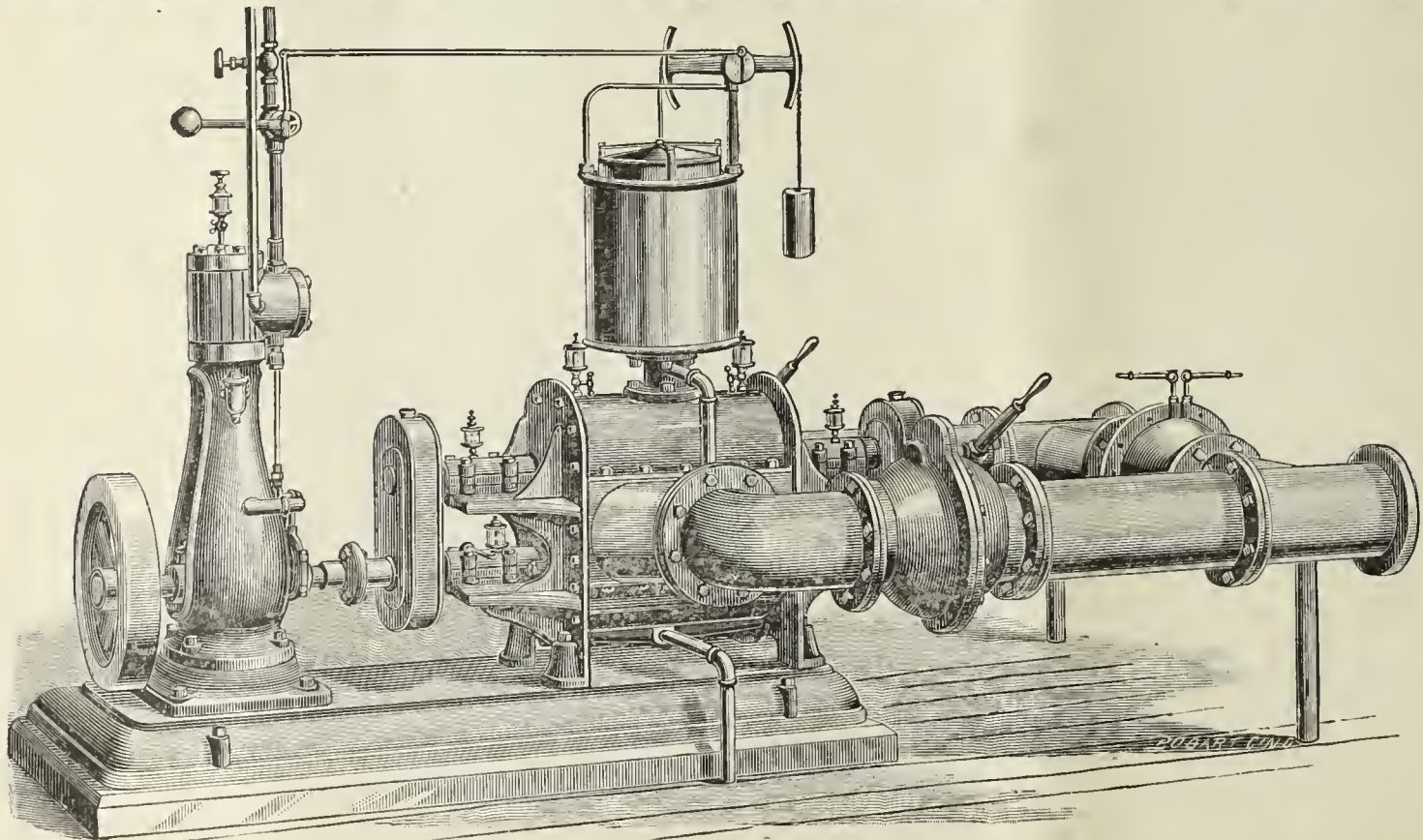

We will take pleasure in furnishing estimates on complete plants, including **GAS EXHAUSTER, ENGINE,** and **GAS GOVERNOR,** all connected, complete, on same bedplate. Also, estimates for **GAS VALVES, BYE-PASS VALVES,** and **PIPE FITTINGS,** arranged in any manner to suit the exhauster room or main connections.

All flanges of pipe and valve fittings faced off, with bolt holes drilled, all ready to go together.

S. S. TOWNSEND, General Agent, }
COOKE & CO., Selling Agents, } 22 Cortlandt St., N. Y. P. H. & F. M. ROOTS CO., Connerville, Ind.

CONNELLY & CO.,

SOLE MANUFACTURERS OF THEIR PATENTED SPECIALTIES.

"IRON SPONGE."

Saves money, saves labor, and is the most efficient purifying agent ever offered as a substitute for lime. Now used in every State in the Union, and purifying daily over thirty-five million cubic feet. Should be used in every gas works. Its own saving will pay for it many times over.

AUTOMATIC GOVERNOR.

Has been on the market but three years, and in that time has been introduced more generally than any invention ever designed for use in gas works. Over two hundred of them now in use. Sensitive; reliable; perfectly automatic; reduces leakage; satisfies consumers, and gives great relief to the Manager. No gas works is complete without one of these machines.

STEAM JET EXHAUSTER.

Designed particularly for small works. Combines Exhaust Tube, Steam Governor Gas Compensator, and Bye-Pass Valves in the most compact form possible; occupies but little space; uses very little steam; operated by ordinary workmen; saves formation of carbon in retorts; increases yield 10 to 15 per cent. Specially adapted for mixing air with oil gas. No works too small to use them profitably.

Prices given on all our specialties delivered at any point in the United States. Correspondence solicited.

CONNELLY & CO., No. 111 Broadway, New York City.

WILBRAHAM GAS EXHAUSTER

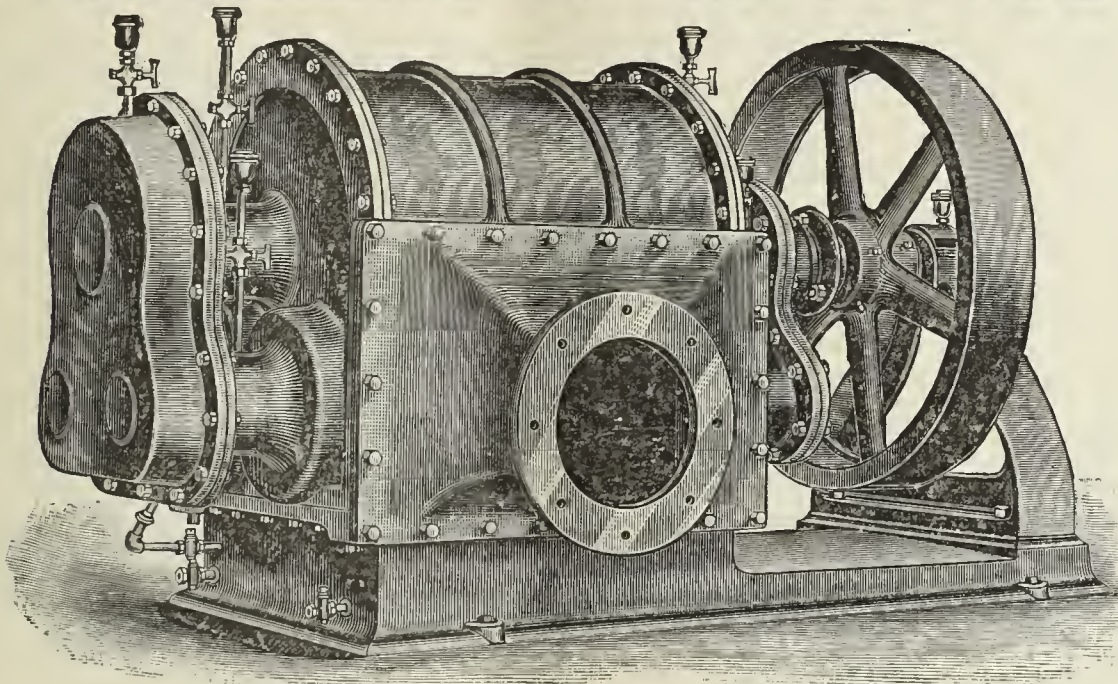

WILBRAHAM BROS.,
PHILADELPHIA, PA.

JARVIS ENGINEERING CO.,

61 Oliver St., Boston, Mass.

CONTRACTORS FOR ERECTING

COMPLETE STEAM OUTFITS FOR ELECTRIC LIGHTING STATIONS.

Steel Boilers set with Jarvis Pat. Boiler Setting

To burn COKE SCREENINGS for Fuel.

ARMINGTON & SIMS CO. ENGINES,

Belting direct to Dynamos, without using Shafting.

SEND FOR CIRCULARS.

REFERENCES.—Charlestown Gas & Electric Light Co., Charlestown, Mass.; Schenectady Gas & Electric Light Co., Schenectady N. Y.; Brookline Gas Co., Brookline, Mass.

Practical Electric Lighting

By A. BROMLEY HOLMES, A.M.I.C.E.

With 87 Illustrations. Third Edition. Price, \$1.00.

Electric Light Primer.

By CHARLES L. LEVEY.

A simple and comprehensive Digest of all the most important facts connected with the running of the Dynamo and Electric Lights, with Precautions for Safety, etc.

Price, 50 cents.

A. M. CALLENDER & CO., 42 Pine St., N. Y.

Gasholder Tanks & Gas Works Masonry Complete.

PLANS PREPARED AND ESTIMATES FURNISHED AT SHORT NOTICE.

J. P. WHITTIER, - - 499 Wythe Av., Brooklyn, N. Y.

1890 DIRECTORY 1890

OF THE GAS LIGHT COMPANIES of the UNITED STATES & CANADA.

Price, \$5.00.

A. M. CALLENDER & CO., No. 42 Pine Street, N. Y. City.



CHAPMAN VALVE MANUFACTURING CO.,

MANUFACTURERS OF

Valves and Gates for Gas, Ammonia, Water, Etc.

Also, Gate Fire Hydrants With and Without Independent Nozzle Valve. All Work Guaranteed.

WORKS & GEN'L OFFICE:
Indian Orchard, Mass.

TREASURER'S OFFICE:
72 Kilby & 112 Milk Sts, Boston, Mass.

LUDLOW VALVE MFG. CO.

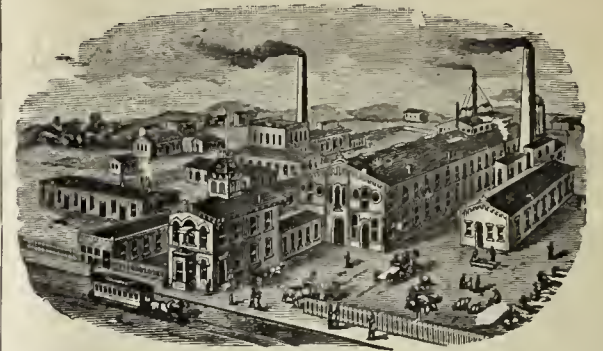

OFFICE AND WORKS,

938 to 954 River Street and 67 to 83 Vail Av.,
TROY, N. Y.

Parson's Steam Blower,

FOR IMPROVING BAD DRAUGHT IN BOILERS, AND FOR BURNING BREEZE OR OTHER WASTE MATERIAL.

PARSON'S TAR BURNER,

FOR UTILIZING COAL TAR AS FUEL.

PARSON'S AIR JET TUBE CLEANER,

FOR CLEANING BOILER TUBES.

These devices are all first-class. They will be sent to any responsible party for trial. No sale unless satisfactory. Manufactured by the WATERTOWN STEAM BLOWER COMPANY.

H. E. PARSON. Supt., 33 & 35 Liberty St., N. Y.

MILLS' REVERSIBLE LIME TRAY,

AND

WOODWORK

Of Every Description

NEEDED BY GAS WORKS.

SEND FOR CIRCULAR AND PRICE LIST TO

BARTLETT, HAYWARD & CO.,

Pratt and Scott Streets, Baltimore, Md.

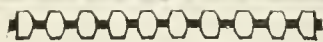
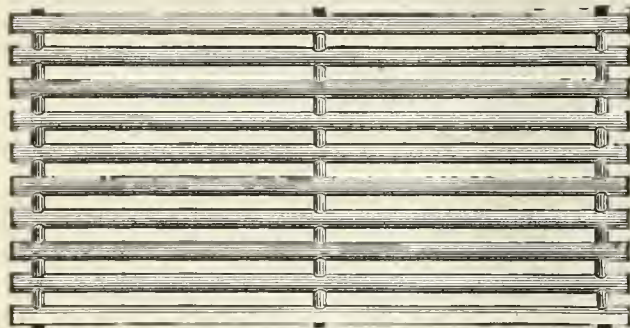

VAN DUZEN GAS & GASOLINE ENGINE

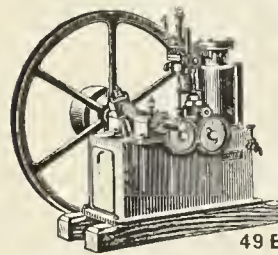

OPERATED with COAL and OTHER MANUFACTURED GASES AND GASOLINE.

RELIABLE AND ECONOMICAL.

Fully Warranted

VAN DUZEN

Gas & Gasoline Engine Co.

49 E. 2d St., Cincinnati, O.

A. MacKinnon Machine Co., Agts., 22 Warren St., N. Y.

The Management of Small Gas Works.

BY C. J. R. HUMPHREYS.

Price, \$1.

Orders to be sent to **A. M. CALLENDER & CO.,**

42 PINE STREET, NEW YORK.

Hydraulic Main Dip Regulators, also Check Valves, Foot Valves, Yard-wash and Fire Hydrants. Send for Circulars.

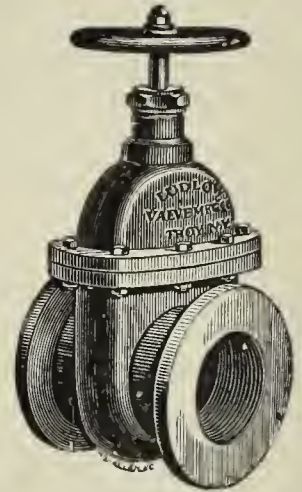

Valves.—Double and Single Gate, 1/2 in. to 48 in., outside and inside Screws. Indicator, etc., for Gas, Water, Steam, and Oil. Send for Circulars.

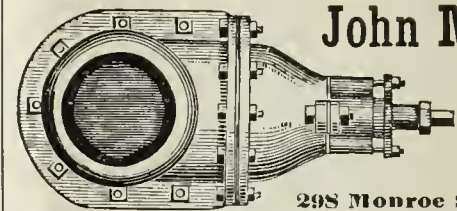

John McLean

Man'facturer

GAS VALVES.

298 Monroe Street, N. Y.

SPECIAL TRAYS FOR IRON SPONGE OR OXIDE OF IRON.
CHURCH'S TRAYS A SPECIALTY.
REVERSIBLE—STRONGEST—MOST DURABLE—MOST EASILY REPAIRED.

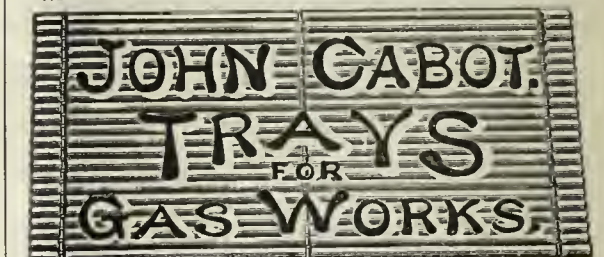

306-310 ELEVENTH AVENUE, NEW YORK.

WE ALSO MAKE THE CHEAPEST AND STRONGEST REVERSIBLE BOLTED TRAYS IN THE MARKET.

THE CLERK GAS ENGINE CO.,
Main Office, 1012, 1014, 1016, 1018 Filbert St., Philadelphia, Pa.

WM. W. GOODWIN, Prest.

E. STEIN, Sec.

S. LEWIS JONES, Asst. Sec.

A. J. DOTY, Supt.

The utility and convenience of the Gas Engine being no longer an open question, it only remains now for intending purchasers to select the BEST. We claim for the CLERK GAS ENGINE that it is equal to any other manufactured as regards steadiness in running, simplicity, and ease of keeping in repair, and that it gives the greatest amount of power for the least money (both in first cost and expense of running) of any engine made. In support of this claim we refer to the test of the Gas Engines made under the direction of the American Institute of New York, in December, 1885, and heretofore published in these columns. These engines are especially adapted for continuous running under heavy loads, and we can refer to Engines which have run 22 hours a day for months at a time!

Made in Sizes of 5, 10, 15, 20, and 25 Horse Power. All Engines Guaranteed for One Year.

ENGINEERS.

P. D. WANNER, Chairman. A. H. MELLERT, Mangr. of Wks.
R. B. KINSEY, Secretary. F. A. KNOPP, Treasurer.

MELLERT FOUNDRY & MACHINE CO. Ltd.
and **READING FOUNDRY CO., Ltd.**
Reading, Pa.



**Specials—Flange Pipe, Valves and Hydrants
Lamp Posts, Retorts, etc.**
General Foundry and Machine Work.
JOHN FOX, Selling Agent. 160 Broadway, N. Y.

THE OHIO PIPE COMPANY,

MANUFACTURERS OF

Cast Iron Gas & Water Pipe,

BRANCH AND SPECIAL CASTINGS.

Gas-House Bench Castings, Hydraulics, Lamp Posts, Flange Pipe
and Specials, Architectural Castings, Building Columns,
Joists, Cellar Grates, Sash Weights, etc.

GENERAL FOUNDERS AND MACHINISTS.
Columbus, Ohio.

M. J. DRUMMOND,



SPECIAL CASTINGS AND LAMP POSTS.
Office, Corbin Building, 192 Broadway, N. Y.

EMAUS PIPE FOUNDRY.

DONALDSON IRON COMPANY. EMAUS, PA.



MANUFACTURERS OF

CAST IRON PIPE AND SPECIAL CASTINGS
FOR WATER AND GAS.

JOS. R. THOMAS,

No. 42 Pine Street, N. Y. City.

**CONSULTING AND CONSTRUCTING
Gas Engineer and Contractor.**

PLANS, SPECIFICATIONS, AND ESTIMATES
FURNISHED.

**Contracts taken for all Appliances
required at a Gas Works,**
Either for New Works or Extensions to Old Plants.

WM. MOONEY

(Successor to WM. FARMER)

No. 94 Liberty St., N. Y. City.

**GAS ENGINEER AND CONTRACTOR FOR THE ERECTION
OF GAS WORKS, OR APPARATUS OF ANY
CAPACITY.**

Plans and Specifications Furnished.

**WM. GARDNER,
Gas Engineer,**

Lewis Block, Room 20, Pittsburgh, Pa.

Those who intend to make alterations in existing gas plants, or
who contemplate the erection of new works, will find it to their
interest to open correspondence with the above. Plans made
and estimates furnished.

GAS AND WATER PIPES.

SAM'L R. SHIPLEY, Pres.
HENRY B. CHEW, Tre

GLOUCESTER IRON WORKS,
GLOUCESTER CITY, N. J.



JAS. P. MICHELON, Sec.
WM. SEXTON, Supt.

Cast Iron Gas & Water Pipes, Stop Valves, Fire Hydrants, Gasholders. &c.

Office, Rooms 61 and 63 Bullitt Building, 131 S. 4th St., Phila., Pa.

WARREN FOUNDRY AND MACHINE CO.,

Established 1856.

Works at Phillipsburgh, N. J.

New York Office, 160 Broadway.

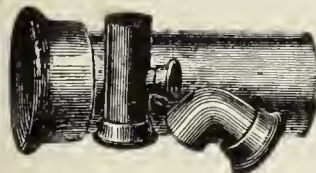

CAST IRON WATER AND GAS PIPE,

FROM TWO TO FORTY-EIGHT INCHES DIAMETER. ALSO, ALL SIZES OF

Flange Pipe for Sugar House and Mine Work. Branches, Bends, Retorts, etc., etc.

DENNIS LONG & COMPANY,

LOUISVILLE, KY.,



**CAST IRON GAS & WATER PIPE & SPECIAL CASTINGS
OF ALL SIZES.**

King's Treatise on Coal Gas.

A standard text-book for the Engineers and Managers of Gas Works, and for all who are concerned
or take an interest in the manufacture and distribution of Coal Gas, and in the utilization of the
Secondary Products resulting therefrom; treating also of the Gas Engine, and of Gas Cooking and
Heating Appliances

In 3 Vols. Price per Vol., \$10. Sold either by Volume or in Sets.

A. M. CALLENDER & CO., 42 Pine St., N. Y.

RETORTS AND FIRE BRICK.

J. H. CAUTIER & CO.,
CORNER OF
GREENE AND ESSEX STREETS,
JERSEY CITY, N. J.

MANUFACTURERS OF
**Clay Gas Retorts,
Gas House Tiles,
Fire Bricks, Etc. Etc.**
Ground Clay, Fire Brick and
Fire Sand in Barrels,

J. H. GAUTIER. C. E. GREGORY. C. E. GAUTIER.

BROOKLYN
Clay Retort & Fire Brick Works,
(EDWARD D. WHITE & CO.)
Manufacturers of Clay Retorts, Fire Brick,
Gas House and other Tile.
VAN DYKE, ELIZABETH, RICHARDS & PARTITION STS.
Office, 88 Van Dyke St., Brooklyn, N. Y.

RETORTS AND FIRE BRICK.

LACLEDE FIRE BRICK MFG. CO.,
MANUFACTURERS OF
Fire Brick, Gas Retorts,

AND
ST. LOUIS STANDARD SEWER PIPE.
Blast Furnace and Cupola Linings, every description of Fire
Clay Material, Fire Clay Flue Linings, Chimney Tops
Dry Milled and Crude Fire Clays, etc.
OFFICE AND DEPOT
901, 903, and 905 Pine Street,
ST. LOUIS, MO.

ESTABLISHED IN 1845.
B. KREISCHER & SONS,
OFFICE FOOT OF HOUSTON ST., E. B., N. Y.
**Gas Retorts,
TILES, FIRE BRICK.**
AND EVERYTHING IN THE FIRE CLAY LINE.

RETORTS AND FIRE BRICK.

MANHATTAN
FIRE BRICK & ENAMELLED CLAY
RETORT WORKS
ADAM WEBER.

**CLAY GAS RETORTS
AND RETORT SETTINGS**
FIRE BRICKS, TILES, ETC.,
Office and Works, 15th Street and Avenue C., N. Y.



Works,
LOCKPORT STATION, PA.

ESTABLISHED 1864.
JAMES GARDNER, JR.,

Office, Rooms 19 & 20, Lewis Block,
PITTSBURGH, PA. P. O. Box 373.

Successor to WILLIAM GARDNER & SON.

Fire Clay Goods for Gas Works.

H. A. NORTON, No. 4 CENTRAL STREET, BOSTON, MASS., Agent for the New England States.

GEO. C. HICKS, Prest. **CHICAGO** CHAS. A. REED, Sec. & Treas.

Retort and Fire Brick Co.,
MANUFACTURERS OF
Fire Clay Goods of all Kinds,
AND BEST QUALITY ONLY.
Regenerative Furnaces & Water Gas Goods.
45th St., Clark to La Salle, Chicago.

GEROULD'S IMPROVED RETORT CEMENT.
A Cement for patching retorts, putting on mouthpieces, and
making up all bench-work joints. This Cement is mixed ready
or use. Economic and thorough in its work. Fully warranted
o stick. For recommendations and price list address
C. L. GEROULD & CO.,
5 & 7 Skillman St., Brooklyn, N. Y.
Western Agent. H. T. GEROULD, Mendota, Ill.

Parker-Russell
Mining and Mfg. Co.,

CITY OFFICE,
Mermod-Jaccard Bldg., Rooms 307 & 308,
Broadway & Locust St., St. Louis. Mo.

PROPRIETORS OF THE
OAKHILL GAS RETORT & FIRE BRICK W'KS
Our immense establishment is now employed almost entirely in
the manufacture of
Materials for Gas Companies

We have studied and perfected three important points. Our re-
torts are made to stand changes of temperature, the strongest
heats of the furnace, and the abrasion of feeding and emptying.
We have the exclusive Agency for the West of the celebrated
**Kloenne-Bredel Full Depth and
Semi-Recuperator Benches,**
And also furnish and build
Our Own Styles Semi-Recuperator Furnaces
for the use of Coal or Coke as fuel.

THOS. SMITH, Prest. AUGUST LAMBLA, Vice-Prest. & Supt.

BALTIMORE
RETORT & FIRE BRICK CO.

MANUFACTORY AT
LOCUST POINT, BALTIMORE, MD.

Clay Retorts, Blocks & Tiles
**FIRE BRICK, FIRE CLAY,
AND FIRE CEMENT.**

**Red and Buff Ornamental Tiles and Chim-
ney Tops. Drain and Sewer Pipe (from
2 to 30 inches). Baker Oven Tiles
12x12x2 and 10x10x2.**
WALDO BROS., 88 WATER ST., BOSTON, MASS
Sole Agents the New England States.

Boston Fire Brick Works Manufacturers of **Gas Retorts and Settings**

Under the Personal Supervision of MR. GEO. C. HICKS late of Chicago.

Fire Clay Goods of all kinds. Akron Sewer Pipe, Lime, Cement, etc. Agts. for the Arc Gas Lamp & Governing Gas Burners.
Send for Circulars and Prices to

FISKE, COLEMAN & CO., Managers, No. 62 Congress Street, Boston, Mass.

HENRY MAURER & SON,
 (ESTABLISHED 1856.)
EXCELSIOR FIRE BRICK & CLAY
RETORT WORKS
 WORKS, Perth Amboy, N. J.
 OFFICE, 418 to 422 East 23d St., N. Y.
Clay Gas Retorts,
BENCH SETTINGS,
 Fire Brick, Tiles, Etc.

FLEMMING'S
Generator-Gas Furnace

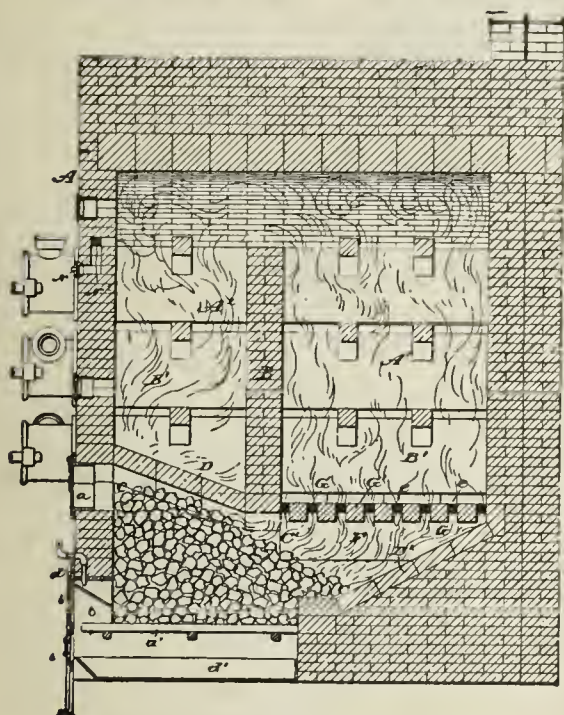

Materials furnished and Benches erected by

J. H. GAUTIER & CO., - Jersey City, N. J.
 Address as above, or D. D. FLEMMING, Jersey City, N. J.

FRED. BREDEL,
 CONTRACTOR FOR THE COMPLETE
Erection and Equipment of Gas Works.
 SOLE PROPRIETOR OF THE
KLOENNE PATENTS
 FOR NORTH AMERICA.

REGENERATIVE FURNACES.

(900 Retorts are now fired in America by the Kloenne-Bredel System.)

SELF-SEALING MOUTHPIECES.

(Over 800 Now in Use.)

Standard Condensers. Washer-Scrubbers.

TAR WASHERS FOR WATER GAS PLANTS.

(In use in the works of the Chicago Gas Lt. Co.)

GASHOLDERS.

Bredel's Automatic Gas Governor.

Refers, by permission, to Mr. Eugene Vanderpool, Newark, N. J.; Mr E. G. Cowdery, Milwaukee, Wis.; and Mr. Theo. Forstall, Chicago, Ills. For further information, address

FRED. BREDEL,
No. 208 East Seventeenth Street, N. Y. City.

SCIENTIFIC BOOKS.

KING'S TREATISE ON THE MANUFACTURE OF COAL GAS. Three vols.; \$10 per vol.
 GAS MANUFACTURE, by WILLIAM RICHARDS. 4to., with numerous Engravings and Plates, in Cloth binding. \$12.
 TECHNICAL GAS ANALYSIS. \$2.80.
 GAS CONSUMER'S GUIDE. \$1.
 A GUIDE TO GAS LIGHTING. 40 cents.
 GAS MEASUREMENT AND GAS METER TESTING, by F. W. HARTLEY. \$1.60
 GAS CONSUMER'S HANDBOOK, by WILLIAM RICHARDS. C.E.; 18mo., Sewed. 20 cents.
 A PRACTICAL TREATISE ON GAS AND VENTILATION with Special Relation to Illuminating, Heating, and Cooking Gas, by E. E. PERKINS. \$1.25.
 PRACTICAL TREATISE ON HEAT, by THOMAS BOX. Second edition. \$5.

GAS WORKS—THEIR ARRANGEMENT, CONSTRUCTION, PLANT, AND MACHINERY. \$8.
 COAL; ITS HISTORY AND USE, by PROF. THORPE. \$3.50.
 THE GAS WORKS OF LONDON, by COLBURN. 60 cents.
 THE GAS FITTER'S GUIDE, Showing the Principles and Practice of Lighting with Coal Gas, by JOHN ELDREDGE. 40 cents.
 GAS WORKS, AND MANUFACTURING COAL GAS, HUGHES. \$2.20.
 THE MANAGEMENT OF SMALL GAS WORKS, by C. J. R. HUMPHREYS. \$1.
 MANUAL FOR GAS ENGINEERING STUDENTS, by D. LEE, 40 cents.
 HOW TO MANAGE GAS, by F. WILKINS. Paper. 20 cents.
 THE DOMESTIC USES OF COAL GAS, AS APPLIED TO LIGHTING, by W. SUGG. \$1.40.
 DIGEST OF GAS LAW. \$5.

DISTILLATION OF COAL TAR AND AMMONIACAL LIQUOR, by GEO. LUNGE. New Edition. \$12.50.
 A TREATISE ON THE COMPARATIVE COMMERCIAL VALUES OF GAS COALS AND CANNELS, by D. A. GRAHAM 8vo., Cloth. \$3.
 GAS COMPANIES DIRECTORY. \$3.
 GAS VERSUS ELECTRIC LIGHT. 50 cents.
 THE AMERICAN GAS ENGINEER AND SUPERINTENDENT'S HANDBOOK, by WM. MOONEY. \$3.
 GAS ENGINE INDICATOR DIAGRAM, by W. E. AYRTON. Paper. 20 cents.
 ILLUMINATING AND HEATING GAS, by W. BURNS. \$1.50.
 TESTING PIPES AND PIPE JOINTS, by M. M. PATERSON. 80 cents.
 DESIGNING WROUGHT AND CAST IRON WORK, by H. ADAMS. Paper. three parts, 60 cents each.
 NOTES IN MECHANICAL ENGINEERING, by H. ADAMS. \$1.
 STRAINS IN IRONWORK, by H. ADAMS. With plates. \$1.75

The above will be forwarded by express, upon receipt of price. If sent by mail, postage must be added to above prices. We take especial pains in securing and forwarding any other Works that may be desired, upon receipt of order. All remittances should be made by check, draft, or post office money order.

A. M. CALLENDER & CO., 42 Pine Street, New York.

Newbigging's Handbook for Gas Engineers and Managers.

The present (the fifth) edition marks an important advance on those that have gone before. Considerable additions have been made to the text, and much of it has been re-written and otherwise improved. It extends to 524 pages, and contains 193 illustrations. Price, Cloth, \$6.00.

A. M. CALLENDER & CO., - - - No. 42 Pine Street, N. Y. City.

DAVIS & FARNUM MFG. CO.,

WALTHAM, MASS.

PRINCIPAL OFFICE AND WORKS, Waltham, Mass.

BOSTON OFFICE, Room 55, Mason Building, 70 Kilby Street.

SINGLE, DOUBLE,
AND
TRIPLE LIFT

Gas holders.

OF ANY CAPACITY.

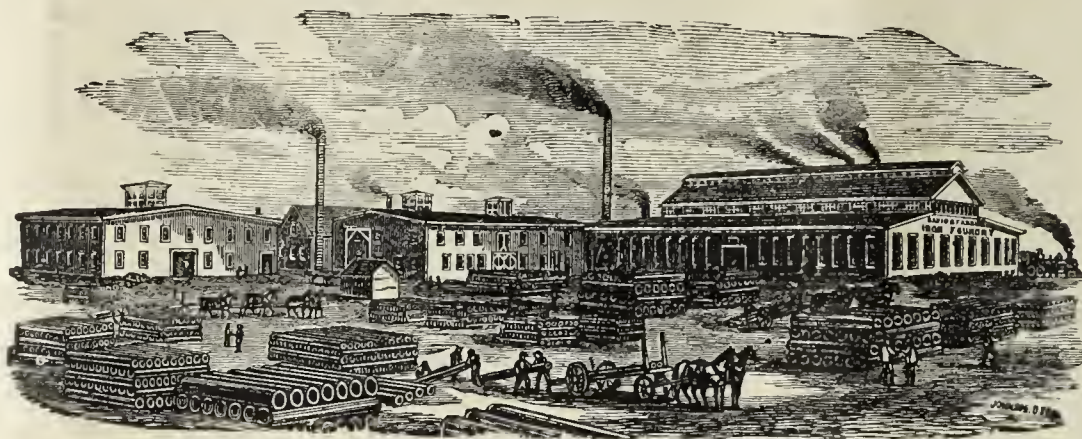

TUBULAR, PIPE,
AND
SINUOUS FRICTION

Condensers.

OF ALL SIZES.

IRON ROOF FRAMES AND FLOORS.

Purifying Boxes, Center Seal or Valve Connections, Bench Work.

Reversible Lime Trays.

SELF-SEALING AND PRESSED STEEL MOUTHPIECE LIDS.

Coke Barrows, Coal Wagons, and all Apparatus Requisite for a Complete Gas Plant.

— ALSO —

Gas and Water Pipe, Flanged Pipe,

Sugar House Work, and Special Castings of all Descriptions.

Established 1861.

Incorporated 1881.

KERR MURRAY MFG. CO.,

FORT WAYNE, IND.

Those who are in need of

Holdings of Gas Works Apparatus of any Description,

AND OF THE LATEST IMPROVEMENTS,

will find it to their interest to

GET AN ESTIMATE FROM US

before placing their order.

As we make a Specialty of this Class of Work, and are Practical Builders and Manufacturers of same,

with our long years of experience in the business,

WE CAN GUARANTEE YOU SATISFACTION.

Estimates, Plans and Specifications Furnished on Application.

BARTLETT, HAYWARD & CO.

Baltimore, Md.

Triple Double, & Single-Lift
GASHOLDERS.

Iron Holder Tanks.

ROOF FRAMES.

Cirders.

BEAMS.

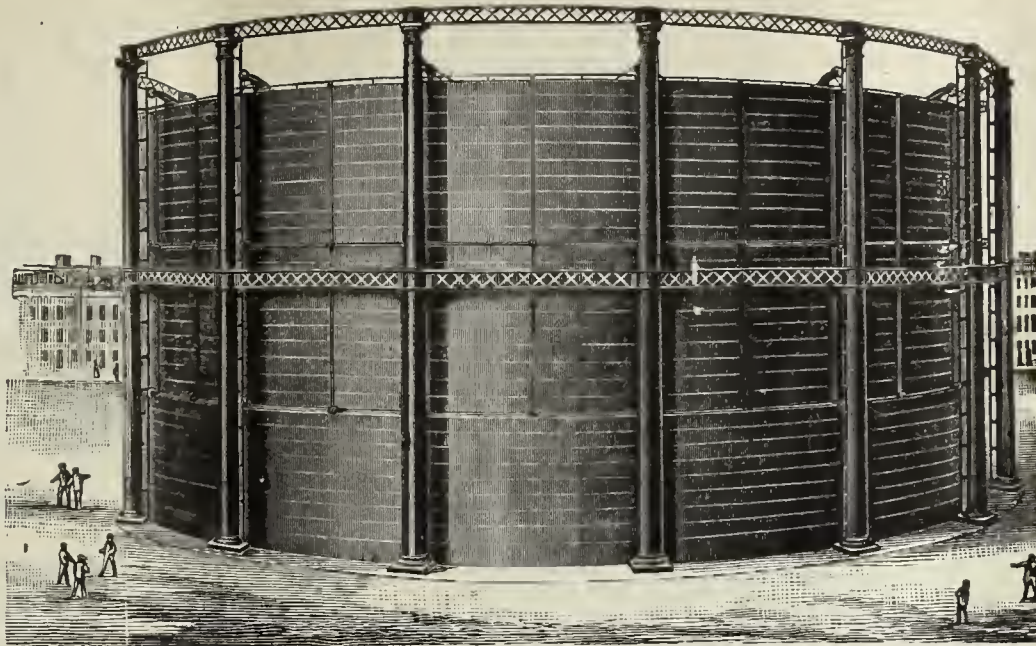

PURIFIERS.

CONDENSERS.

Scrubbers.

BENCH CASTINGS.

OIL STORAGE TANKS.

Boilers.

The Wilkinson Water Gas Process.

THIRTY-CANDLE, NON-CONDENSABLE, FIXED GAS. THE MOST SUCCESSFUL GAS PROCESS IN OPERATION.

Munich Regenerative Furnace, System Drs. Schilling & Bunte.

HAZELTON BOILERS.

Gas Works Designed and Constructed.

Pascal Iron Works. ESTABLISHED 1821. Delaware Iron Works.

MORRIS, TASKER & CO.,

INCORPORATED.

OFFICE, 224 SOUTH THIRD STREET, - - PHILADELPHIA, PA.

CONTRACTORS, BUILDERS, AND MANUFACTURERS OF

Gas, Water & Sugar Works

Bench Castings.

Condensers.

Scrubbers.

Purifiers.

Hyd. Carriages.

Iron Floors,

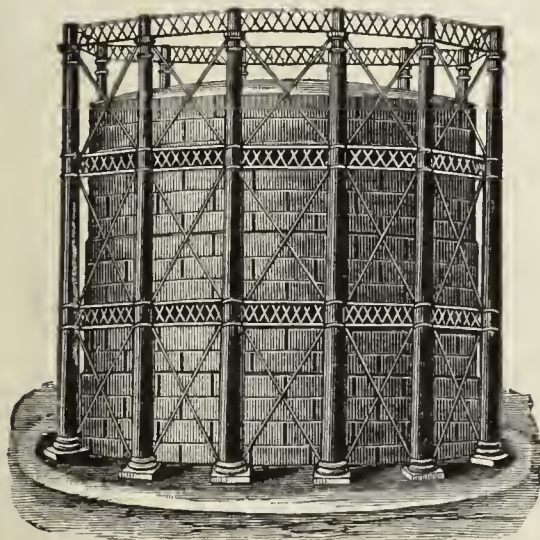

Iron Roofs.

Street Stops,

Valves, etc.

Stand-Pipes.

Water & Oil

Tanks, all Sizes.

Single, Double, and Triple-Lift Gas Holders.

SELF-SEALING RETORT LIDS. STAMPED STEEL RETORT LIDS.

Locomotive Water Columns, Filters, etc. Boiler Tubes, Wrought Iron Pipe & Fittings

Plans, Specifications and Estimates for all kinds of Machinery furnished on application.

Foundries & Works,
MILLVILLE, FLORENCE,
and CAMDEN, N. J.

R. D. WOOD & CO.,

Engineers,
Iron Founders,
and
Machinists.

400 Chestnut St., PHILADELPHIA, PA.

MANUFACTURERS OF

CAST IRON PIPE,

Gas Holders,

SINGLE, DOUBLE, AND TRIPLE LIFTS, WITH
OR WITHOUT WROUGHT IRON
OR STEEL TANKS.

PURIFIERS, CONDENSERS.

Scrubbers.

BENCH WORK.

Iron Floors and Roofs, Plate Girders.

Heavy Loam Castings.

HYDRAULIC WORK.

Lamp Posts, Valves, Etc.

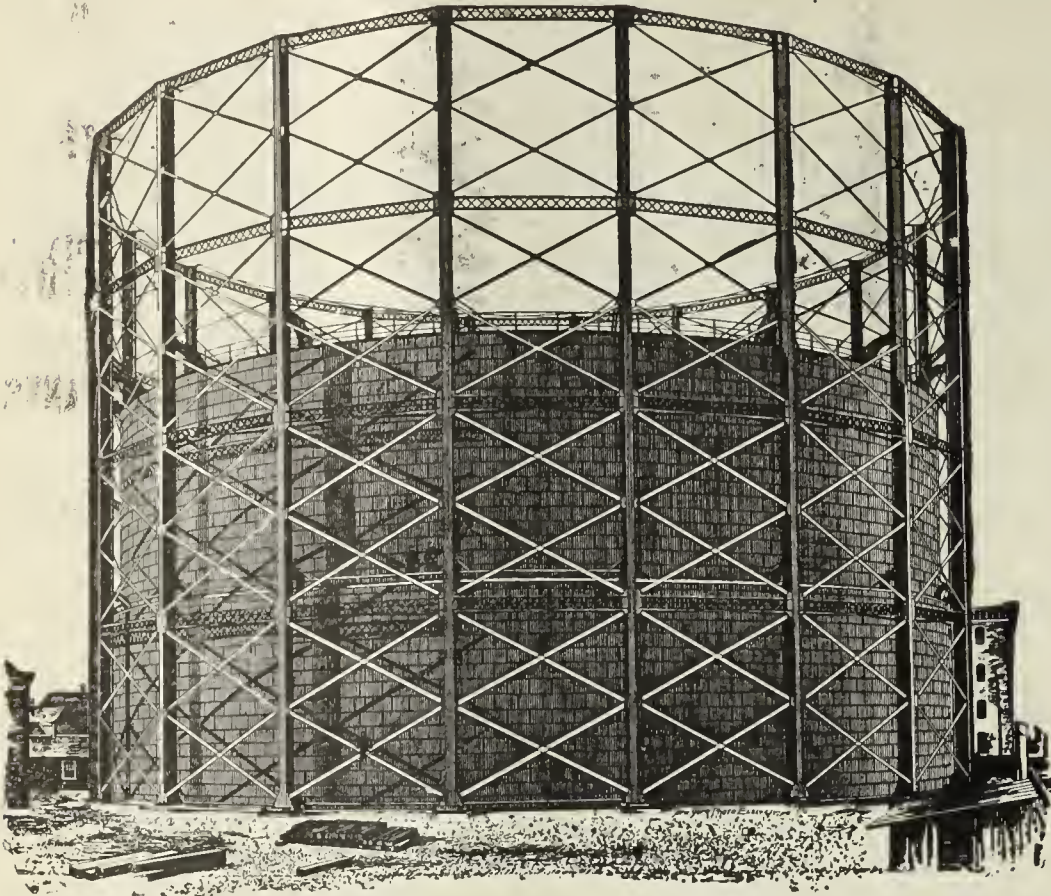

SMITH & SAYRE MFG. COMPANY,

G. G. PORTER, Prest.

245 Broadway, N. Y. CHAS. W. ISBELL, Sec'y.

Machinery & Apparatus for Gas Works

Drawings, Plans, and Estimates Furnished for the Improvement, Extension, or Alteration of Gas Works, or for the Construction of New Works.

Mackenzie's Patent Rotary and Steam Jet Gas Exhausters, Governors, Compensators, Condensers, Washers, Scrubbers. Isbell's Patent Automatic Street Pressure Governor, Gas and Water Valves, Hydraulic Main Dip Regulator, Bench Castings, etc. Purifying Boxes and "Standard" Scrubbers Isbell's Patent Self-Sealing Retort Doors

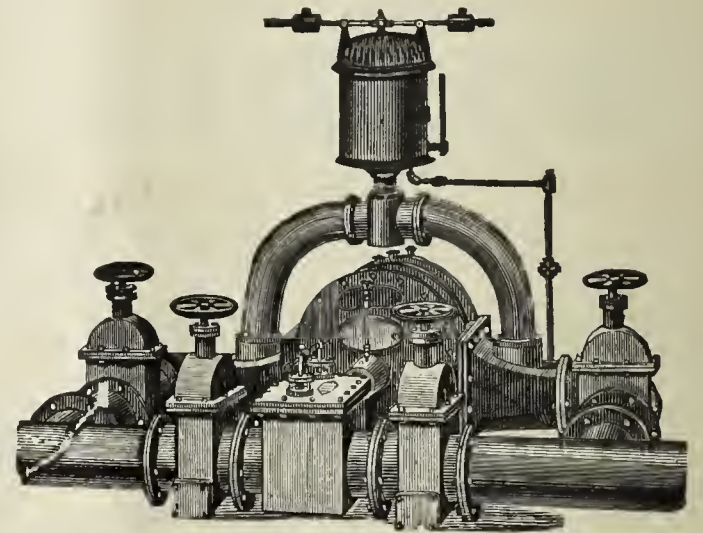

THE BRENNER SELF-SEALING RETORT DOOR.

Simple, Strong, and Durable.

CLOSES ABSOLUTELY TIGHT & IS LOCKED BY A CAM LEVER. ALL NECESSARY ADJUSTMENT FOR WEAR PROVIDED.

BUILT BY

SMITH & SAYRE MFG. CO.,

No. 245 Broadway, - - - - New York City.

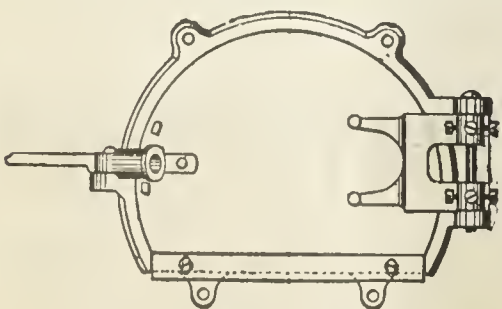

Brenner Self-Sealing Retort Door.

WILLIAM B. LUNDIE, Superintendent of the 42d Street Station of the Consolidated Gas Company, of New York, writes, under date of Jan. 4, 1889:

"We have 320 Brenner Self-Sealing Lids in use at this Station, built by the Smith & Sayre Mfg. Co. They require very little attention, and are the best of the kind that I have seen, giving entire satisfaction."

GAS WORKS APPARATUS AND CONSTRUCTION.

GAS WORKS APPARATUS AND CONSTRUCTION.

JAMES R. FLOYD & SONS,

(SUCCESSORS TO HERRING & FLOYD)

Oregon Iron Works,

W. 20th & 21st. Sts., bet. 10th & 11th Aves.,

NEW YORK CITY.

Engineers and Contractors

FOR THE

CONSTRUCTION OF GAS WORKS.

MANUFACTURERS OF

All Kinds of Castings and General Ironwork

FOR

GAS APPARATUS.

Bench Castings, Regenerative and Half Regenerative Furnace Castings.

Condensers, Scrubbers, Purifiers, Street Drips and Connections,

Valves,

Hydraulic Hoisting Purifier Carriage, Self-Sealing Retort Lids, Improved

Valve Stand and Indicator, Seller's Cement.

Plans, Specifications, and Estimates furnished for Construction of New or Alteration of Old Works.

CONTINENTAL IRON WORKS.

THOS. F. ROWLAND, Prest.

WARREN E. HILL and CHAS. H. CORBETT, V-Prests.

THOS. F. ROWLAND, JR., Sec. & Tr

P. O. Station G., BROOKLYN, N. Y.

ENGINEERS AND MANUFACTURERS OF

Gas Holders

CONDENSERS, SCRUBBERS, VALVES,

PURIFIERS, SELF-SEALING RETORT LIDS

Hydraulic Mains,

And all other articles connected with the manufacture and distribution of Gas.

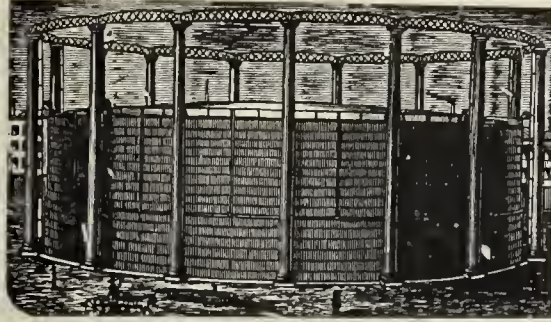

H. RANSHAW, Prest. & Mangr.

WM. STACEY, Vice-Prest.

T. H. BIRCH, Asst. Mangr.

R. J. TARVIN, Sec. & Treas.

STACEY MFG. CO.,

MANUFACTURERS OF

Single and Telescopic Gasholders,

IRON ROOFS, BRIDGES, LAMP POSTS,

Water and Oil Tanks, Coal Elevator Cars,

COKE CRUSHERS, BENCH CASTINGS,

And all kinds of Wrought and Cast Iron Work used in the erection of Coal and Oil Gas Works Rolling Mill Machinery and Heavy Castings a Specialty.

Foundry:

33, 35, 37 & 39 Mill Street.

Wrought Iron Works:

16, 18, 20, 22, 24 & 26 Ramsey Street:

Cincinnati, Ohio.

Bouton Foundry Co.,

FOUNDERS AND MACHINISTS,

CHICAGO, ILL.

Gas Works Apparatus,

PURIFIERS, CONDENSERS,

Bench Work

SPECIALS, LAMP POSTS,

SCRUBBERS,

Iron Roofs and Floors.

Plans and Estimates furnished for new works or extensions of old works.

1842. **DEILY & FOWLER, 1890.**

Laurel Iron Works.

Address, No. 39 Laurel Street, Philadelphia, Pa.

BUILDERS OF

GASHOLDERS,

Single and Telescopic.

HOLDERS BUILT 1884 TO 1888, INCLUSIVE:

- | | | | | |
|----------------------------|-----------------------------|---------------------------|--------------------------|------------------------|
| Newport, R. I. | Long Island City, N. Y. | Port Chester, N. Y. | Malden, Mass. | West Chester, Pa. (2d) |
| Portland, Oregon. | Macon, Ga. | New Rochelle, N. Y. | Paducah, Ky. | Lancaster, Pa. (3d) |
| Allegheny, Pa. (2d.) | York, Pa. | Salem, N. J. (3d) | Norwich, Conn. | Facny, Pa. (two) |
| Atlanta, Ga. (2d.) | Chester, Pa. | Omaha, Neb. (2d) | Seattle, W. T. | Mount Vernon, N. Y. |
| N.Y. City (Central Gas Co) | Hazleton, Pa. (2d.) | Lynn, Mass. (2d) | San Diego, Cal. | Binghamton, N. Y. |
| Lynchburg, Va. (2d.) | Staten Island, N. Y. | Little Rock, Ark. | Northern Gas Lt. Co., of | Concord, N. H. |
| Saylesville, R. I. | Saugerties, N. Y. | Irvington, N. Y. | New York, N. Y. | Dover, Del. (2d) |
| Rondout, N. Y. | Clinton, Mass. (Lan. Mills) | South Boston, Mass. | Westerly, R. I. | Calais, Me. |
| Atlantic City, N. J. | Chattanooga, Tenn. | Rye, N. Y. (2) | Willimantic, Conn | New London, Conn. (3d) |
| Augusta, Ga. | Galveston, Texas. (3d.) | Woodstock, Ont. | Montclair, N. J. | West Chester, N. Y. |
| Waltham, Mass. (2) | Omaha, Neb. | Malden, Mass. | Attleboro, Mass. | Bay Shore, L. I. |
| Mahanoy City, Pa. | Fort Plain, N. Y. | Staten Island, N. Y. (2d) | Santa Cruz, Cal. | Washington, D. C. |
| New Castle, Pa. | Brunswick, Ga. | Woodstock, Ont. | Erie, Pa. (2d) | |

WM. HENRY WHITE,

No. 32 Pine Street, - - - New York City.

ENGINEER AND CONTRACTOR FOR THE

ERECTION AND EXTENSION OF

GAS, WATER, AND ELECTRIC LIGHT WORKS.

Correspondence with Gas Companies contemplating extending or improving their Plants respectfully invited. Plans and Estimates Furnished.

GAS COALS.

CANNEL COALS.

GAS ENRICHERS.

JAMES D. PERKINS. **PERKINS & CO.,** F. SEAVERN.
228 & 229 Produce Exchange, New York.

Cable Address, "PERKINS, NEW YORK."

Post Office Box 3695, New York.

GENERAL SALES AGENTS FOR

The Youghiogeny River Coal Company's

OCEAN MINE YOUGHIOGHENY GAS COAL.

HON. W. L. SCOTT, Prest.

M. H. TAYLOR, Vice-Prest.

This Colliery is located at SCOTT HAVEN, PA., in the center of the Youghiogeny Gas Coal District, and produces the ONLY RELIABLE YOUGHIOGHENY COAL for gas purposes. (See Map on p. 87 of this JOURNAL, Feb. 16, '85.)

POINTS OF SHIPMENT,

Locust Point, BALTIMORE.

Pier No. 62, PHILADELPHIA.

Also, SOLE AGENTS for the

**BRECKENRIDGE CANNEL,
OF KENTUCKY.**

Within the past two years we have delivered this Cannel to over ONE HUNDRED COMPANIES IN THIRTY-THREE DIFFERENT STATES, and it is now in use in some of the large Gas Works

On the Continent and in South America,

where it successfully competes with the Australian Shale. It is the ONLY AMERICAN GAS CANNEL of sufficiently high grade to warrant EXPORTATION TO EUROPE AND SOUTH AMERICA, and it is the only economical substitute for OIL OR NAPHTHA. ONE GROSS TON will produce

10,000 Cubic Feet of 75 Candle Gas,	} equal to {	750,000 Candle Feet of Gas, and 26 Bushels of merchantable Coke weighing 900 Pounds
or 12,500 " " 60 " "		
or 15,000 " " 50 " "		

This is the ONLY GAS CANNEL that will produce a REALLY MERCHANTABLE COKE. It can be delivered in parcels of one carload or more to any point in the United States or Canada. Cargo shipments of any size required can be made from NEW YORK, PHILADELPHIA, BALTIMORE, or NEWPORT NEWS. Samples will be sent and particulars of price, etc., forwarded upon application to above address.

JAMES & WILLIAM WOOD,

Gas and Cannel Coal Contractors,

No. 40 St. Enoch Sq., Glasgow. No. 2 Talbot Court, London.

Proprietors of the BATHVILLE COLLIERIES (which produce the celebrated BOGHEAD CANNEL), Shields, Shieldmuir, Drumpeller, and other Collieries. This Firm offer

STANDARD CANNELS,

Unequaled as Gas Enrichers.

Also, WEST FAIRMONT GAS COAL, of W. Va.

Analyses, prices, and all further information furnished on application to

Agency for U. S., Room 70 Nos. 2 & 4 Stone St., N.Y. City.

The Standard Oil Company,

REFINERS OF

NAPHTHA AND GASOLINES.

ALSO MANUFACTURERS OF

A Special Grade of Naptha for Gas Companies

FOR ENRICHING COAL GAS.

Correspondence solicited.

No. 43 Euclid Avenue, Cleveland, Ohio.

To Gas Companies.

We make to order CAP BURNERS to burn any amount under a stated pressure. Send for samples.

Also, SERVICE CLEANERS, DRIP PUMPS, and STREET MAIN PROVING APPARATUS.

O. A. GEFROER,

248 N 5th Street, Phila., Pa.

COKE CRUSHERS.

Newburgh Orrel Coal and Coke Co.

MINERS AND SHIPPERS OF

STEAM, SMITHING, AND GAS COALS,
Foundry and Crushed Coke.

Home Office, 33 S. Gay Street, Baltimore, Md.

J. HARRY LEE, President.

Shipping Wharves, Locust Point, Baltimore.

The Despard Gas Coal Co.,

MINERS AND SHIPPERS OF

DESPARD GAS COAL,

AND MANUFACTURERS OF

COKE.

MINES, Clarksburg, Harrison Co., W. Va.

WHARVES, Locust Point, Baltimore, Md.

OFFICE, 225 E. German St., " "

ROUSSEL & HICKS, } AGENTS. } BANGS & HORTON,
71 Broadway, N. Y. } 60 Congress St., Boston.

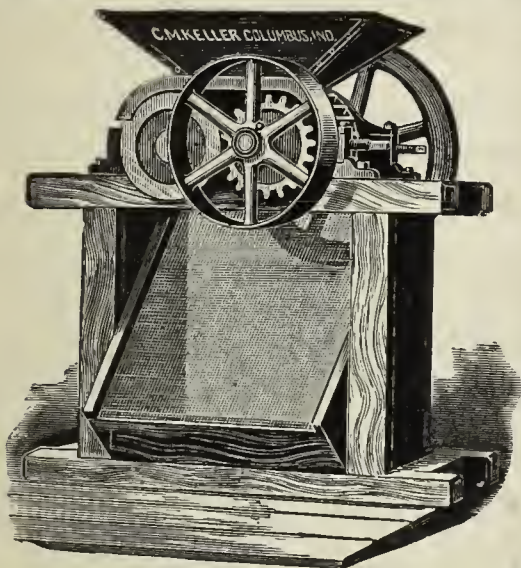

Keller's Adjustable Coke Crusher.

SIMPLE, STRONG, AND DURABLE.

C. M. Keller, Sec. & Supt. Gas Lt. & Coke Co. Columbus, Ind.

Correspondence Solicited.

King's Treatise on Coal Gas.

The most complete work on Coal Gas ever published.

Three Vols. Bound, \$30.

BOOKS.

DISTILLATION OF COAL TAR AND
AMMONIACAL LIQUOR.

By GEORGE LUNGE. Price \$12.50.

A TREATISE ON THE COMPARATIVE
COMMERCIAL VALUES OF GAS
COALS AND CANNELS.

By DAVID A. GRAHAM. 8vo., Cloth. Price \$3.

Orders for these books may be sent to this office.

A. M. CALLENDER & CO.,

42 PINE ST., N. Y. CITY

GAS COALS.

GAS COALS.

THE
PENN GAS COAL CO.

OFFER THEIR

Coal, Carefully Screened & Prepared for Gas Purposes.

Their Property is located in the Youghiogheny Coal Basin, near Irwin and Penn Stations on the Pennsylvania Railroad, and on the Youghiogheny River.

Principal Office:

209 SOUTH THIRD STREET, PHILA., PA.

Points of Shipment:

Pennsylvania Railroad Piers; Greenwich Wharves, Delaware River; Pier No. 1 (Lower Side), South Amboy, N. J.

Chesapeake & Ohio Railway Coal Agency,

FOR THE SALE OF THE

Superior Kanawha Gas Coals, Cannelton Cannel,
Also, SPLINT AND STEAM COALS,

From the Kanawha and New River Regions, on the line of the Chesapeake & Ohio R'way.

C. B. ORCUTT, General Agent, - - No. 1 Broadway (Room 217) New York City.

FRANCIS H. JACKSON, Prest.

EDMUND H. MCCULLOUGH, V.-Prest.

CHAS. F. GODSHALL, Treas.

H. C. ADAMS, Sec.

THE WESTMORELAND COAL CO.

Chartered 1854.

Mines situated on the Pennsylvania and the Baltimore and Ohio Railroads, in Westmoreland County, Penn.

POINTS OF SHIPMENT:

PHILADELPHIA, BALTIMORE, SOUTH AMBOY, N. J.,
WATKINS (SENECA LAKE), N. Y.

Since the commencement of operations by this Company its well-known Coal has been largely used by the Gas Companies of New England and the Middle States, and its character is established as having no superior in gas-giving qualities, and in freedom from sulphur and other impurities.

Principal Office, 224 South 3d St., Phila., Pa.

The American Gas Engineer
and Superintendent's Handbook.

By WILLIAM MOONEY.

Consisting of Rules, Reference Tables, and Original Matter
Pertaining to the Manufacture, Manipulation, and
Distribution of Illuminating Gas.

350 Pages, Full Gilt Morocco.

\$3.00.

A. M. CALLENDER & CO., 42 Pine St., N. Y.

JOHN J. GRIFFIN & CO.,

Nos. 1513, 1515, 1517 & 1519 Race Street, PHILADELPHIA.
52 Dey St., NEW YORK. 75 N. Clinton St., (FRED. R. PERSONS, Mangr.) CHICAGO.

MANUFACTURERS OF

METERS FOR MEASURING GAS

IN ANY VOLUME.

Provers, Gauges, Registers, Etc., Etc

EXPERIMENTAL APPARATUS FOR QUANTITATIVE AND QUALITATIVE ANALYSIS.

Careful and Prompt Attention paid to Repairing of all kinds of Meters and Apparatus.

Estimates Cheerfully Furnished.

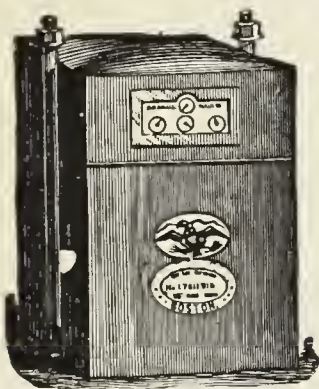

Dry Gas Meters.

With 40 years' experience and the best facilities for manufacturing, is enabled to furnish reliable work and answer orders promptly.

NATHANIEL TUFTS,

No. 153 Franklin Street, Boston, Mass.,

MANUFACTURER OF

DRY GAS METERS.

Station Meters of any Capacity.

Test and Experimental Meters, Pressure Registers, Pressure Gauges, Pressure and Vacuum Gauges.

METER PROVERS, PHOTOMETERS, STREET LANTERNS, ETC., ETC.

Patent Cluster Lanterns for Street Illumination.

HAROLD J. BELL.

BELL & JONES,

S. LEWIS JONES.

No. 12 North Ninth Street, Philadelphia, Pa.

Works at Royersford, Pa.

MANUFACTURERS OF

GAS METERS, STATION AND EXPERIMENTAL METERS,
Meter Provers, Pressure Gauges, and All Other Gas Appliances in Our Line.

WE REPAIR ALL KINDS AND MAKES OF METERS, AND THE WORK GUARANTEED.

High Pressure Meters for Natural Gas, in Iron Cases, guaranteed to stand 300 lbs. Pressure.
Gas Cooking and Heating Stoves, Hot Plates, Cake Griddles, Waffle Bakers, Boiling Stoves, Laundry and Tailors' Iron Heaters. Hotel and Cafe Ranges a Specialty.

Correspondence Solicited.

Estimates Furnished.

A. HARRIS.

E. L. HARRIS.

J. A. HARRIS.

Established 1849.

HARRIS BROS. & CO.,

Twelfth and Brown Streets, Philadelphia.

Manufacturers of Wet and Dry Gas Meters,

STATION METERS, METER PROVERS,

EXPERIMENTAL METERS, SHOW OR GLAZED METERS,

Pressure and Vacuum Registers, Gauges, Photometers, Drip and Bell Pumps, Etc., Etc.

PROMPT ATTENTION GIVEN TO ALL ORDERS. METERS THOROUGHLY REPAIRED. ESTIMATES FURNISHED FOR STATION METERS OF ALL SIZES. CORRESPONDENCE SOLICITED.



GAS METERS.

GAS METERS.

GAS METERS.

GEO. J. MCGOURKEY, Prest.

WM. H. MCFADDEN, Vice-Prest. (Phila.)

WM. N. MILSTED, Gen. Supt. and Treas. (New York).

WM. H. DOWN, Sec.

THE AMERICAN METER CO.

Established 1834.

Incorporated 1863.

WET AND DRY GAS METERS.

PRESSURE REGISTERS.

METER PROVERS.

STATION METERS.

PRESSURE & VACUUM REGISTERS.

PORTABLE TEST METERS.

EXHAUSTER GOVERNORS.

PRESSURE & VACUUM GAUGES.

EXPERIMENTAL METERS.

DRY CENTER VALVES.

CRESSON GAS REGULATORS.

AMMONIA TEST METERS.

GOVERNORS FOR GAS WORKS.

MARSLAND WATER METERS.

BAR & JET PHOTOMETERS.

Manufactories:

512 West 22d St., N. Y.

Arch & 22d Sts., Phila.

GAS STOVES.

SUGG'S "STANDARD" ARGAND BURNERS,

SUGG'S ILLUMINATING POWER METER,

Wet Meters, with Lizar's "Invariable Measuring" Drum.

Agencies:

177 Elm Street, Cincinnati.

244 & 216 N. Wells Street, Chicago.

510 North Second Street, St. Louis.

222 Sutter Street, San Francisco.

HELME & McILHENNY,

(Established 1848.)

GAS METER MANUFACTURERS,

Nos. 1339 to 1349 Cherry Street, Philadelphia, Pa.,

WET AND DRY GAS METERS. STATION METERS, EXPERIMENTAL METERS, METER PROVERS,

Center Seals, Pressure Registers, Governors, Indicators, Photometers, and all other kinds of Apparatus for use in Gas Works.

FOULIS' PATENT STATION AND DISTRICT GOVERNORS.

REPAIRING DEPARTMENT.—We employ a special force of skilled workmen repairing meters of all makers.

WM. WALLACE GOODWIN, President and Treasurer.

E. STEIN, Vice-President.

H. B. GOODWIN, Secretary and Superintendent.

THE GOODWIN GAS STOVE AND METER CO.,

Successors to W. W. GOODWIN & CO.

1012, 1014 and 1016 Filbert St., Phila., Pa.

113 Chambers St., New York City.

76 Dearborn, St., Chicago, Ills.

WALDO BROTHERS, Agents, 88 Water Streets, Boston, Mass.

MANUFACTURERS OF

DRY AND WET GAS METERS,

Station Meters (square, cylindrical, or in staves), Glazed Meters, King's and Sugg's Experimental Meters, Lamp Post Meters, etc., etc. Meter Provers (sizes 2, 5, and 10 feet), Pressure Gauges of all kinds, Pressure Registers, Pressure and Vacuum Registers, Pressure Indicators (sizes 4, 6, and 9 inch), King's Pressure and Vacuum Gauges, Dry and Wet Center Seals, Dry and Wet Governors, Exhauster Governors, Photometers of all descriptions. Letheby's Sulphur and Ammonia Test Apparatus complete. Also, Testing and Chemical Apparatus of all kinds, and of the most perfect description, for all purposes relating to Gas.

Manufacturers of the "SUN DIAL" GAS STOVES, for Cooking and Heating.

Goodwin's Improved Lowe's Jet Photometer.

Agents for Bray's Patent Gas Burners and Lanterns.

Special attention to Repairs of Meters and all Apparatus connected with the business. All work guaranteed first-class in every particular. Orders filled promptly.

G. B. EDWARDS, Manager, New York.

S. S. STRATTON, Manager, Chicago.

D. McDONALD & CO.,

GAS METER MANUFACTURERS.

(Established 1854.)

51 Lancaster St., Albany, N. Y.

34 & 36 West Monroe St., Chicago, Ill.

STATION METERS, EXPERIMENTAL METERS, METER PROVERS, PRESSURE & VACUUM REGISTERS, PRESSURE GAUGES, ETC.

Also STAR GAS STOVES, RANGES, and HEATING STOVES.

We use only the very best materials, and employ the most skilled labor, and by our long experience (36 years) and personal supervision of every detail we feel justified in assuring the public that our goods will give perfect satisfaction. Every Meter emanating from our establishment will bear the State Inspector's BADGE, and will be fully warranted by us. Our Annual and Calendar will be sent to Gas Companies upon application.

GAS INTO POWER,

BY THE

OTTO GAS ENGINE.

GAS POWER.—A Source of Revenue to Gas Companies ready to engage in Electric Lighting, building of Water Works, Electric Street Railways, etc.

Coal for producing Gas is less in amount than that for producing Steam, both being measured on an equal amount of work performed. And, further, with Gas,

50 to 90 per Cent. of Value of Coal is Returned

by sale of Coke and Tar, according to the market value of these products.

Labor for handling fuel is reduced, by its becoming centralized and confined to the gas house, and frequently has not increased after the addition of a power station.

With Gas Power, cost of fuel is strictly limited to the time of use.

MANY VALUABLE
AND RECENT
IMPROVEMENTS.

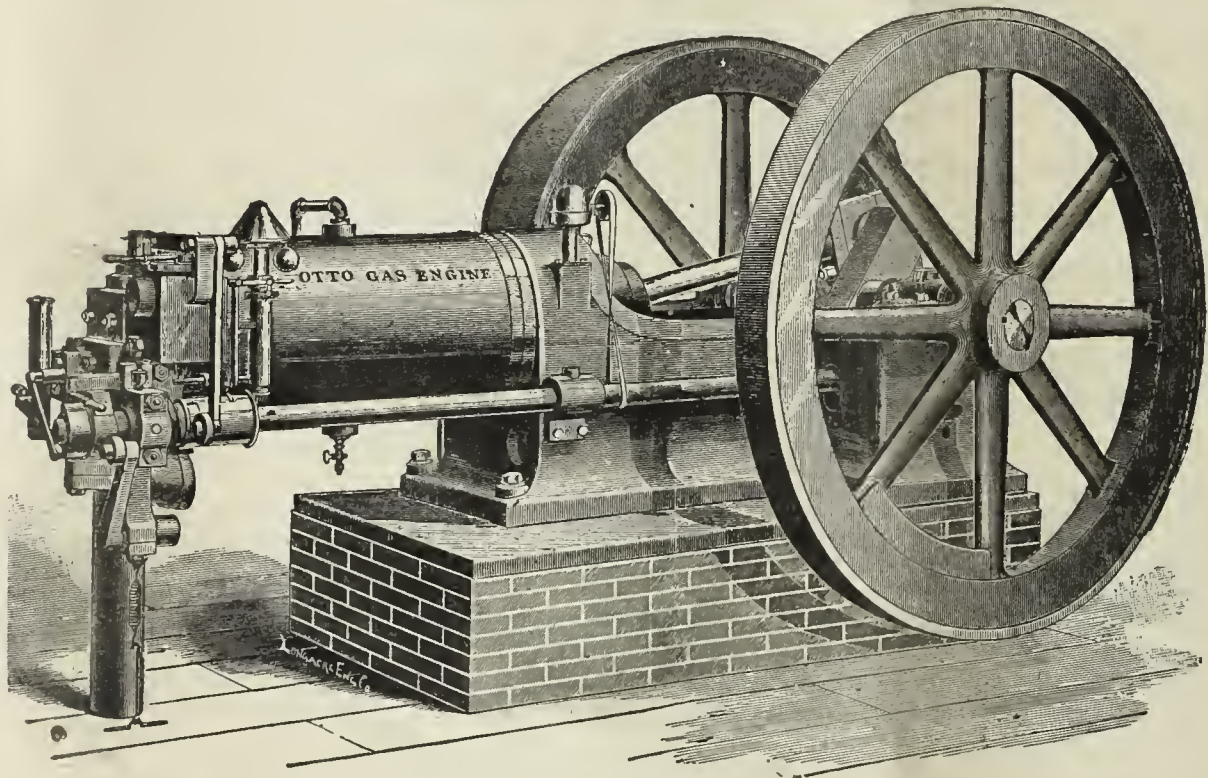

SIZES,
1-3 to 100
HORSE POWER.

Wherever Gas Companies tried Gas Power with Steam Power together in one Station, the use of Steam was subsequently abandoned or restricted, and Gas Power made to take its place.

Where Gas Companies adopt Gas Power for Electric Plants, Water Works, Sewerage, etc., they not only choose the most economical power for their use, but secure to themselves the numerous advantages of increased production, without increase of expense, and benefit thereby their entire manufacture. They induce consumers, by their example, to abandon Steam for Gas Power, and, by establishing special rates, make

Gas Power the Leading Power of To-Day,
AND SOLVE AT ONCE THE QUESTION OF FUEL GAS.

“Otto Gas Engine Works,”

SCHLEICHER, SCHUMM & CO.,

151 Monroe St. (Kent Building), Chicago.

33d & Walnut Sts., Phila.

NEW YORK AGENCY, 18 VESEY STREET.

THE AMERICAN

GAS LIGHT JOURNAL

REDMAN & KENNY, N. Y.

PUBLISHING OFFICE No. 42 PINE STREET

DEVOTED TO THE INTERESTS OF ILLUMINATION, VENTILATION, WATER SUPPLY AND DISTRIBUTION, & GENERAL SCIENCE.

VOLUME LII.—No. 21.
Whole No. 781.

NEW YORK, MONDAY, MAY 26, 1890.

{ \$3 PER ANNUM,
IN ADVANCE.

A. M. CALLENDER & CO., Proprietors. C. E. SANDERSON, Manager.
JOS. R. THOMAS, C. E., Editor. T. J. CUNNINGHAM, Asst. Editor.

ENTERED AT THE POST OFFICE AT NEW YORK, N. Y.
AS SECOND CLASS MATTER.

Published on each Monday of the year, at No. 42 Pine Street, N. Y.

Terms of Subscription, Including Postage.—For the United States and Canada, \$3 per annum. European countries, \$4.50 (19 shillings—22½ francs). All payments to be made in advance. Single copies, 10 cents.

Remittances should be made either by post-office order, registered letter, or bank draft on New York, payable to the order of A. M. Callender & Co.

Collections are invariably made directly from this office, for subscriptions, advertisements, etc. We have agents to solicit the same, but they are not authorized to receipt for money.

Correspondence.—Wishing to make this JOURNAL a gazette of intelligent discussion to those of our readers who may wish to gain or give information on the subjects to which its columns are devoted, correspondence is solicited for publication from all who make the study of those subjects a pleasure or a profession.

The American News Company, Nos. 39 and 41 Chambers street, New York, are agents for this JOURNAL. Newsdealers will send orders to them.

Books.—We will forward by express, at publisher's lowest rates, any book—scientific or otherwise—to any address in the United States or Canada. No book will be sent C. O. D.

CONTENTS.

An Asterisk (*) denotes an illustrated article.

EDITORIALS—

Our Photograph of Mr. Egner.....	729
An Advance Budget from "Three Stars".....	729
Briefly Told.....	730
A Bad Verdict—Notes—Annual Election, Macon, Ga.	
The Market for Gas Securities.....	730
Gas Burners for Illuminating Purposes.....	731
*Cosh's Apparatus for the Manufacture of Gas.....	732
*Portable Photometer for Electric Lights.....	733
The Poetsch System of Excavating, by Mr. E. L. Abbott.....	734
Carcass Roofing, by Mr. J. Robinson.....	735
Dangers of Gas and Geyser Baths.....	735
Special English Correspondence.....	737
Enterprise in Gas Supply—Gas and Ventilation—Yeadon's Improved Retort.	
The Opinion of the Attorney-General of Massachusetts in Respect to the Right of Cities and Towns to Operate Gas and Electric Light Plants.....	738

ITEMS OF INTEREST FROM VARIOUS LOCALITIES..... 739

Main Extension, Troy, N. Y.—The Coney Island Company Changes Hands—To be Sold at Auction—Gas Company for Olympia, Wash.—New Rates for Gas, Montreal—The Manchester (N. H.) Suit—Coze Benches—General Hickenlooper has Something to Say—The Standard Gas Company's Bid for City Lighting—Annual Meeting, Carlisle, Pa.—New Holder for Altoona, Pa.—A Hint from Perth Amboy, N. J.—Notes from Helena, Mont.—Soon he will Marry—Gas Rates at Milton, Pa.—New Works for Bloomington, Ills.—Cheaper Gas for Oswego, N. Y.—Damage Suit—Personal—Refused Permission to Disturb the Streets, at Wilmington, Del.—And Many Other Items.

WITH this issue of the JOURNAL we present to our subscribers an excellent photographic likeness of Mr. Frederic Egner, President-elect of the Western Gas Association, and Chief Engineer of the Laclede Gas Light Company, of St. Louis. Mr. Egner is so well known to the fraternity at large in his capacity as an engineer, and to our readers as an able writer, through the many valuable articles that have been penned by him in our columns, that we deem any biographical notice unnecessary. It is all-sufficient to say that he is a credit to the fraternity in every sense and respect.

AN ADVANCE BUDGET FROM "THREE STARS."

St. Louis, Mo., May 21, 1890.

DEAR JOURNAL:—I cannot do better, I think, in beginning this summary of the first day's proceedings of the Western's 13th annual, than to bluntly say that if the other twelve "first days" were good, this, the "thirteenth first day," is simply "best." Of course, good weather being necessary to the perfect enjoyment of any sort of gathering "when one is away from home," I am glad to say that clear atmospheric conditions are not lacking, although some would not likely complain were the mercury in the temperature measurers less disposed to rise. In other words, 'tis rather hot. The attendance is simply grand, something over 150 having responded to roll call, with the more than likelihood that "another hundred" will report to-morrow. The Eastern delegation is out in great force, and our reception, in respect to heartiness and hospitality, cannot well be transcribed "over the wires." One must have participated in it to appreciate it. Slater, of Providence, modest as ever, despite the result in the legislative arena of his State, smiles benignly over the gas man from Hartford, and Humphreys, of Lawrence, insists on reminding Capt. White, of New York, of how much he is indebted to him for that "lift" at Baltimore last fall, while the Captain has his hands well occupied in the attempt to keep Weber, of New York, from bubbling over in his effervescence. Brother Down, of New York, as usual, is quiet and observant, and Leach, of Taunton, bears his honors—he was elected to Honorary Membership in the Association to-day—with true Bay State dignity. But if I am to say something about all the "Eastern boys" that have reported, your space (perhaps the patience of your readers, too) would be all too small. Forgive me for adding that Turner, of Charleston, looking every inch a gas man, is with us, and I will go on with a word or two about the business proper. President Faben, having had the satisfaction of listening to fully 150 respond to their names at muster roll, had the further pleasure of knowing that by the close of the day no less than 50 new members had been elected; and it goes without saying that Secretary Littleton is almost "puffed up with pride" over the result. So he ought to be, for he worked like a beaver to secure it. The President's address is a most valuable document; we all knew beforehand, however, that it could be nothing else. I will not attempt to foreshadow it here. You will print it later on, when it shall speak for itself, and speak forcibly, too. So far, Chollar's paper on the "Relative Value of Gaseous Fuels" is one of the very best papers that I have ever heard read before any Association, and stamps him as a man of great resource. Some of the deductions are brought

out so clearly that we imagine even the "fuel gas enthusiasts" of the ultra type will pause in their maunderings, when confronted by the Chollar law of reason. Great praise should be given to Egner for his paper "On the Abuse of the Patent System, as Bearing on the Gas Industry, with a Remedy." It was certain that he would be entertaining; it is also certain that he was instructive. The literary portion of the proceedings so far has been of a remarkably high order, and the direction of business has been of the firm style. Faben never lost his grip of the details. Over our joy one dark cloud constantly hovers, and that is the tempering sadness of the knowledge that he in whose hands the reins of power were placed a year ago is with us only in spirit to-day. The lamented King, however, still rules his subjects through the sway of memory; and all are faithful to the man whose impress on their craft was made with cleverness and without blot.

Those who planned the exhibition of gas appliances have received the greatest award that could be meted to them. The display is simply magnificent, both in plan and scope. I have no doubt that this exhibition will be worth (to the gas companies who have representatives in attendance at this meeting) thousands of dollars. So many valuable hints can be gleaned from inspecting the apparatus on display that it is impossible to go over it and not determine how the day gas consumption of any locality can be increased. I repeat it, the exhibition alone would make memorable the Thirteenth Annual of the Western Association. I shall send you some account of the second day's proceedings on Thursday evening.—*.*

ST. LOUIS, MO., May 22, 1890.

Here we are at the termination of the regular business sessions of the Association, and if I must confess it, just a trifle eager for the order to take up our part in the outing arranged for us by our hosts. In the hurry and confusion of the moment—a confusion, however, that is more pleasing than if straight-laced order prevailed—it is not the most simple task in the world to put down off-hand that which one wants to say respecting events that, though completed in fact, are yet transpiring in fancy. One who is not far from the table at which I write suggests it is a pity the mind cannot occasionally play a snap-shot trick, after the fashion of the followers of the Kodak—that is, "take things in" so that they shall remain "fixed." However, let me say that the proceedings of the second day were like unto those of the first—valuable, instructive and entertaining. To that summary of their worth I may add that the following officers were chosen:

President—Frederic Egner.

Vice-President—E. G. Cowdery.

Second Vice-President—B. E. Chollar.

Secretary—A. W. Littleton.

There; could that list be beaten? Hardly. Louisville, Ky., has been chosen as the next place of meeting, and Barret will probably insist that it is a case of "After the cyclone, a deluge." I would send you more, only the carriage waits.—*.*

BRIEFLY TOLD.

A BAD VERDICT.—Under the circumstances, however, we presume it would be almost an impossibility to secure a verdict that would embody justice. In our item columns will be found an account of a suit, and its unjust preliminary termination, brought by Mrs. Harriet A. Schwab, of Jersey City, N. J., against the United Gas Improvement Company, which, through lease or otherwise, is in control of the gas supply of that city. Complainant, who was a teacher of music, which is fairly good proof that she is a refined and intelligent woman, occupied a house which either was or had been lighted by gas supplied from the mains of defendant. It seems that a joint in the service pipe close to the rising pipe had in course of time become defective, permitting the gas to escape. Plaintiff, it seems, notified defendant of the defective condition of the service (but one notification was made), the notification, as we understand it, having been made about noon of a certain day. Defendant agreed to attend to the matter, but its agents not having arrived by evening of that day, plaintiff repaired to the point where the gas was escaping, and, to assist in a speedy discovery of the exact spot from where the gas was issuing, lighted a match—with the usual result. An explosion ensued, and plaintiff, as the result of her folly, was badly burned about the face, breast, and hands. Subsequently she sued the Company for damages in the sum of \$20,000, and the jury that had the case awarded her the sum of \$6,000. Now, in view of the plain facts—which are substantially as reported above—brought out in the trial of the case, we fail to comprehend the justice of this verdict; that is, if there is any saving merit in the submission of proof of contributory negligence, which proof seems best afforded in the very testimony of plaintiff her-

self. The Judge (Mr. Dixon) charged that the "jury must determine, before awarding damages to plaintiff, whether or not it was careless on her part to light a match in a place where the smell of the escaping gas was so strong, and whether a reasonably prudent person would have done so." His Honor then plainly charged that if she had committed an act of carelessness like this it would prove contributory negligence, which would debar her from recovery of damages. Well, what are the facts in this respect? The woman is a music teacher, and is intelligent and refined. Therefore she must have knowledge that gas and air form a most dangerously explosive compound; and she certainly must have read of a great many cases in which persons, under circumstances identical to those that then prevailed about her, were seriously injured. Does she treasure that knowledge and use it for her protection? No; simple curiosity prompts her to attempt to locate the leak. And in what respect could this knowledge benefit her? We fail to see; but we can and do understand how it could do her positive harm, even without the "aid" of the match. Might she not have been overpowered by the fumes of the gas, and thus suffer bodily ailment? Look at it in what way you will her contributory negligence is clearly proved, but the jury, swayed by sympathy, intensified by a desire to mulct a corporation, disregards law and reason and "mulcts the corporation." This case affords a good example of the necessity of extending the range of actions that should be decided by judges and not by juries. In the meantime we are not blind to the fact that the Company's agents might have acted with greater celerity. The policy of *festina lente* will not do when gas escapes are to be checked.

NOTES.—At the annual meeting of the Farmington (N. H.) Gas Company the following officers were elected: President, Hon. J. F. Cloutman; Vice-President, Edwin Wallace; Clerk, Hon. E. T. Wilson; Treasurer, Hon. C. W. Talpey.—A Halifax (Nova Scotia) alderman, who recently changed the system of lighting his house from gas to incandescent electric lamps, having been notified by the Gas Company that if he did not consume 3,000 cubic feet of gas per quarter his gas meter would be removed, unless he agreed to pay a rental of 50 cents per month for the instrument, threatens to bring suit against the Company. The latter would like nothing better.—The employees of the Wheeling (W. Va.) city gas works demand that 8 hours be fixed upon as the limit for a day's work. If the demand is acceded to it will put an additional expense on the system of not less than \$12,000 per annum.—At the stockholders meeting of the Ogden (Utah) Gas Light and Fuel Company the following officers were elected: D. F. Walker, Sr., President; V. M. C. Silva, Vice-President; Wm. Gill Mills, D. F. Walker, Jr., and John Kempf, Directors. The Company is in prosperous condition.—Mr. W. H. Snyder, who had acted for some time as Superintendent of the United Gas Improvement Company's properties in Paterson, N. J., died at his home in Topeka, Kansas, on the 15th inst.—At the annual meeting of the Montclair Gas and Water Company, Bloomfield, N. J., the following officers were elected: President, Dr. J. H. H. Love; Vice-President, M. M. Dodd; Secretary and Treasurer, W. H. Baldwin; Directors, Eugene Vanderpool, Mathias Plum, S. W. Carey, A. B. Howe and T. W. Langstroth.

THE following is the result of the election for officers at the annual meeting of the Macon (Ga.) Gas Light and Water Company: President, W. J. Goite, of Philadelphia; Vice-President, A. E. Boardman, Macon; Treasurer, Geo. F. Work, Philadelphia; Secretary, J. B. Hall, Macon; Superintendent, J. W. Wilcox, Macon.

The Market for Gas Securities.

The city market for gas shares showed a great deal of animation during the week, and transactions were on a large scale. Consolidated went above 107, and then sagged off on sales for realization. To-day (Friday) it opened at 104 to 104½, and the tone appeared to be weak. It is not at all improbable that an increase in the dividend rate will be made, and there is no doubt whatever that the Company's earnings are quite well in advance of even a 6 per cent. disbursement. It is somewhat amusing now to note the avidity with which the daily newspapers are advising the purchase of gas stocks, and the maunderings of the *Times*, in particular, are interesting. Two years ago that "authority" was all in favor of shares in the electrical companies. Our readers have no reason to find fault with our advice, which was given at a time when they could make money by following it. Brooklyn shares show no change, although the tone of the market is not as buoyant as it was some time ago. Chicago gas has been seen sawing a bit during the week, and is to day at 62½. We think it is high enough just now. Consolidated, of Baltimore, is steady to strong, at 52 to 52½, and there ought to be money in it at these figures, even without "State protection." Laclede common is weaker, while the preferred shows to the contrary. Bay State common is strong at 84. California gas shares are about as before.



Gas Burners For Illuminating Purposes.

The *London Journal*, in discussing this subject says: A prominent American Gas Manager who recently visited this country, and of course extended his peregrinations to the Continent, was heard to remark, with special references to burners and other appliances for the utilization of gas, that there was nothing new in the market. We believe that this verdict is in the main correct. There has been a fair amount of effort resulting in new developments in gas engineering, as we have lately had occasion to recognize; but consumer's apparatus has made little or no advance for several years. In the lighting branch, it is evident that if a comprehensive gas appliances exhibition were to be held this year, it would present hardly anything that could, by the greatest stretch of courtesy, be deemed a novelty. The great class of common open burners, whereby the mass of gas consumers obtain their light, remain absolutely without change, as it has done for these last ten years and more. It would appear as though invention can do no more for these humble yet most useful productions; and that, like the billhook of the Saxon churl, the union jet and the batwing burner have reached their utmost development, which they will keep for the remainder of time. If we turn to the more specialized and differentiated patterns of gas burners, in which (to follow Spencer) change will be more likely than in elementary forms, it is difficult to mark any notable advance. The principle of heat recuperation for the enhancement of the luminous brilliancy has been worked out with tolerable completeness by Mr. Frederick Siemens and his followers and rivals, several of whom appear to have a better appreciation of the requirements of the market than their prototype. There has been much refinement of detail and improvement of pattern in the modern competitive production of recuperative gas lamps; but it would be next to impossible to discriminate in print between the different makes, with a view to distinguishing the best. Some makers aim only at cheapness; others cultivate taste. Others again profess to observe efficiency and economy in use. Infinitesimal divergencies of construction are exaggerated by rival makers into important differences; but, fortunately for themselves, these competitors seem to be wholesomely afraid of taking their conflicting claims into Court. The history of gas burner patents' litigation is not encouraging to a trader who might otherwise be disposed to shift the scene of his struggle with a rival from the shopcounter to the Law Courts. So far as can be determined by a spectator, the competition between makers of the most improved forms of recuperative gas lamps, although keen enough, is conducted on commercial grounds alone. Whether there is much to choose between them, is not for us to say. Suffice it to acknowledge with satisfaction, out of regard to the general interest of the gas industry, that consumers have now at command a considerable choice of really scientifically made and truly efficient gas lamps, such as could not have been bought at any price only ten years ago.

Assuming, however, that the adoption of the regenerative principle for gas lamps has led to a great advance in their construction, which has been of vast benefit both to the industry and to the community, it must still be somewhat disappointing that, to all intents and purposes, a halt has been so soon called in the development of this class of lamps. The huge furnaces consuming 50 cubic feet of gas per hour and upwards, which were common enough on offer when the first makers of these lamps essayed to compete with electric arc lamps, have disappeared. Very few of such gas lamps now in active service take upwards of 20 cubic feet per hour; while the great majority in ordinary use are only half as large as this, or are even smaller. This change is in correspondence with the falling popularity of the electric arc itself, which is now perceived to be unmanageably powerful. It has been found that what the majority of consumers wanted for their warehouses, shops, etc., was an improvement on the amount and quality of the light obtainable from their ordinary gas burners, and not such a radical change of system in lighting as would have been entailed by the general introduction of light centres comparable to the electric arc in intensity. This improvement has been effected by the recuperative gas lamp of moderate power, and by the albo-carbon system of carbureting, which is the only thing of the kind that has really become established in public favor. Hence we see to day, in passing through a street of a good class in any British town, few shops which are not rendered more brilliant and attractive by one or other of these methods of improved gas lighting. The white flame of albo-carbon burners seems to be peculiarly effective for shop windows in which cloths and similarly non-reflecting goods are displayed. A tailor's shop is as difficult to render cheerful as a photometer room; and for the same reason. It is necessary therefore that the means of lighting should be placed in close proximity to the cloth which it is intended to exhibit; and nothing surpasses the albo-carbon burner for

this purpose. Regenerative lamps must be placed overhead and well out of the line of sight.

It is evident, without dissertation on the point, that the great gulf between the cheap and open flat flame burner—and even the refined Argand—and the close, costly recuperative burner is as wide as ever. Even if everybody could afford recuperative lamps, there are many purposes for which they are not so suitable as the less efficient form. The Argand, beloved writers and readers, may sometimes be replaced by the ceiling lamp, or the suspended regenerative lamp of small power; but the radiated heat of the latter is a distinct drawback. It is the increased heat in and surrounding the closed regenerative flame which makes it so much more brilliant than an open burner; but, although the average consumer may be made to believe this, he will none the less complain that the lamp does not keep its excessive heat to itself instead of pouring it on his head. The heat of a gas flame used for lighting an apartment is the same whether the gas is burnt in a lamp glass or in the open. But in the latter case much is taken off by convection, and sent up towards the ceiling, which the regenerative lamp converts into radiant heat that strikes the nearest solid object, whether it be the consumer's head or his walls and furniture. In fact, the regenerative gas burner is the best of all known gas heating stoves. We do not, however, want a stove for warming our heads, even though it sends light to our eyes.

The only practicable kind of gas burners—the incandescent varieties—do not enter largely into the general question. It cannot be argued that they have justified the expectations indulged of them by some people, although it would be too harsh to say that the idea has proved a failure. The difficulty with this order of gas burners is of two kinds. In the first place, it is to supply a material solid and bulky enough to give a good light when strongly heated; and at the same time to present it to the gas flame in such a tenuous or comminuted state that it will readily become white-hot. According to the generally accepted theory of the luminosity of flames—which ascribes this phenomenon to the presence in the highly heated gas of a vast number of particles of solid carbon—anything to surpass this carbon in facility of becoming heated, in fineness of division, and in radiant power when heated, must be hard to find. The makers of incandescent gas lamps profess, however, to have found this desiderated matter in the substances of which their “mantles,” or “combs,” or “meshes” are made. They are never so cheap as carbon, because carbon is one of the very cheapest of elements. In the ordinary way of burning coal gas, moreover, for illuminating purposes, the carbon which gives the light is supplied fresh as fast as required; whereas an extraneous radiant material has to serve for a longer or shorter time until worn out. Even the manufacturers admit that this material loses its efficiency in use, and sooner or later requires to be replaced. The precise point when this occurs is a cause for dissension between the manufacturers of these lamps and their customers; and upon it the whole question of the commercial efficiency of these systems turns. On the whole, we cannot accept as proved the contention that the laboratory efficiency of any incandescent burner, as tested with fresh radiating material, is maintained by its commercial durability.

Thus after passing in review the three orders of gas lighting burners—the open flame, the regenerative, and the incandescent—we cannot signalize any new departure in the utilization of gas for illuminating purposes later than the introduction of the two latter systems. Opinions may differ as to when this took place; and it is hardly worth while to attempt in this article to fix the exact time, which would be tantamount to an acknowledgment of the claims of some particular inventor. It is curious that a period of such activity in this respect as that which ushered in the last decade, should have been followed by such a pause. It is not that there has been indolence on the part of those who are identified with any of the recognized systems. Indeed, never since gas lighting came into vogue has the activity of burner makers been more conspicuous and more fruitful than during the last eight or ten years. The extent to which the knowledge of good and bad in regard to gas burners has been disseminated during this period, although by no means completely to the conviction of consumers, has been greatly in excess of previous years; and it is not too much to say that, in consequence, the average consumer now gets a great deal more for his money than did his predecessor of last generation, who perhaps paid twice as much as the present rates for his gas. Outside the established trade, however, there has been nothing doing for years. Siemens, Wenham, Welsbach, and Lewis were outsiders once. Are there never to be any more innovators, with fresh systems of gas burner construction? All that can be said in answer to this question is that it is a dull time at present, and has been so for some years. Yet, unless one is to accept the conclusion that the last word has been said respecting the best way to develop the illuminating power of gas, it follows that there must be plenty of room for the next inventor in this line, whoever he may be.

Cosh's Apparatus for the Manufacture of Gas.

On May 13th U. S. Letters Patent (No. 427,747) were granted to Wm. M. Cosh, of Baltimore, Md., for an improved process and apparatus for making gas. The current patent is supplementary to one issued March 26th, 1889, and numbered 400,060. The specification reads:

The invention consists of a special construction and arrangement of a generator and superheater or superheaters with their connecting pipes and valves, and also in the arrangement of steam, air and hydrocarbon supply pipes.

It consists, further, of special combination of the duplicate superheaters with the generator and with the connecting pipes and the hydrocarbon and steam supply pipes, whereby different processes can be carried on in the same apparatus, all as hereinafter explained.

In the accompanying drawings Fig. 1 represents the improved apparatus, partly in side elevation and partly in section, the view being from the front; Fig. 2 is a plan view of the same; Fig. 3 shows a rear elevation of the apparatus; Fig. 4 represents a side elevation of the apparatus.

The generator is represented at *A*. It is provided with a grate *M*, adapted to sustain the fuel, and underneath this grate is a space sufficient for the pipes hereinafter described. The generator is adapted to be used with coal, this being the preferred form of fuel and gas generating material; but the apparatus may be adapted to use any other equivalent material as a matter of course. The upper part of the generator is provided with a casting *F'*, which extends obliquely upward toward the front, and is provided with a cap *a*, with means for holding it in place. The opening in this oblique extension is designed for the admission of the fuel. The casting has also another extension *F*, projecting directly upward for connection with the top of the superheaters. This extension is closed at the top, excepting where it admits the lateral pipe of the heater, and it has two pipes *m m'*, extending down through the top, with coils in the lower part. The lower ends of these pipes terminate a suitable distance above the fire surface. The pipes are provided with cocks outside of the casting, and each pipe has also a steam pipe connection, marked respectively, *g g'* these being provided with suitable cocks. Through these pipes steam and hydrocarbon liquid or vapor are admitted and introduced into the top of the generator at a sufficient distance above the surface of the coal for a result hereinafter explained. Below the grate *M* is a pipe *f*, leading to a suitable source of air supply for the purpose of supplying blasts of air to the generator underneath the grate.

In rear of the generator and a little to each side are located chambers *B B'*, adapted to act either as fixing chambers or as superheaters. These are to be filled before using with fragments of brick, or of any other suitable refractory material having interstices through which steam will freely pass, or through which the products of combustion may be drawn, as the occasion in the use of the apparatus may require, as hereinafter explained. Underneath the chamber in which the firebrick fragments of refractory material are to be placed is a combustion chamber *h*. The top of this chamber has an opening upward and downward, with suitable covers, all as shown clearly in Fig. 1. There are passages from the combustion chamber in the base up to the superheating and fixing chamber above the base, and there is also an air supply *i*, which may be provided with a suitable valve (not shown) for supplying air regularly to the mouth in the combustion chamber. The combustion chambers are connected by pipes *C C'*, respectively with the space in the generator beneath the grate *M*, and these pipes are provided with valves *c c'*, for regulating the passage of the gases or cutting them off altogether. A horizontal pipe *E* from the upper part of the generator is connected with the vertical pipe *D*. The lower end of this pipe has horizontal branches (shown in Fig. 3) leading into the combustion chambers *h h*, and through these pipes *E D* and the branches communication is afforded from the top of the generator into the combustion chambers underneath the superheating and fixing chambers. The branches are provided with valves *b b'*, by means of which communication can be cut off between the upper part of the generator and either of the combustion chambers, while the valves *c c'* in the pipes *C C'* serve to cut off communication between the lower part of the generator and either of the combustion chambers. Another set of pipes connects the other superheaters and the generator with the wash-box *W*. Of these pipes *H* extends across from the top of one superheater to the top of the other, and at the latter point it connects with the pipe *H'*, which is turned to meet the pipe *G*. (Shown in Fig. 4.) The pipes *H H'* are shown in Fig. 2. The pipe *G* is on one side of the generator, and has connection with the top and bottom of the generator, and extends down into the bottom of the wash-box *W*. The pipes *H H'* have valves *d d'*, respectively, by means of which communication may be shut off between the upper parts of the superheaters, or

either of them, or the upper part of the generator and the wash-boxes. There are also valves *e e'* in the upper and lower extension of the pipe *G* above and below its junction with its pipe *H'*, which close these passages and may be used to shut off communication from either the upper or lower part of the generator. There are also valves *J J'* on outlet pipes in the bottom of the superheaters, which should be closed when the valves *d d'* are opened. These are the main elements of the apparatus by means of which the various circulations are kept up; but in addition to these there are also oil supply pipes and steam supply pipes, besides those which have been heretofore described in connection with the casing *F*. There are also two steam supply pipes, marked *k k'*, re-

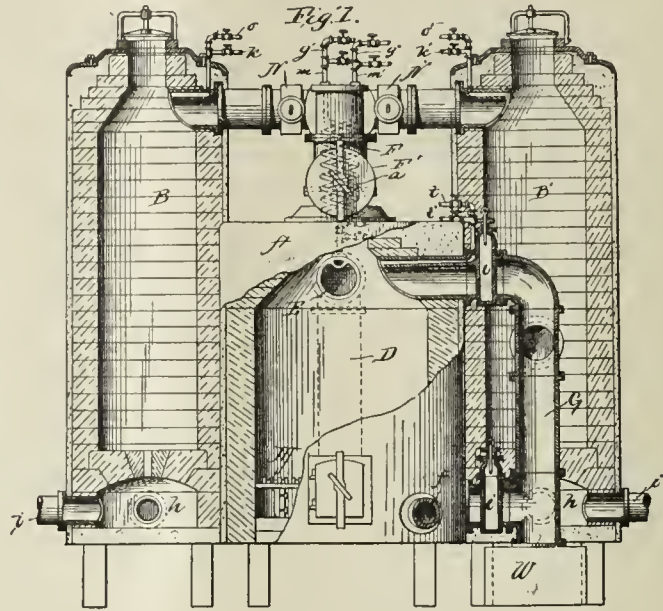

spectively, with their valves, provided also with oil supply pipes *o o'*, also having valves and leading into the top of the superheaters *B B'*, also two steam supply pipes *s s'*, provided with valves and connected with oil supply pipes *R R'*, leading into the chamber of the superheaters *B B'*; also steam supply pipes *u u'*, provided with valves leading into the top of the pipes *C C'*, respectively.

The apparatus heretofore described is adapted to be used in accordance with several methods, slight and easy manipulations of these methods being productive of valuable results. The first of these methods is as follows: The generator is first charged with coal or its equivalent, this

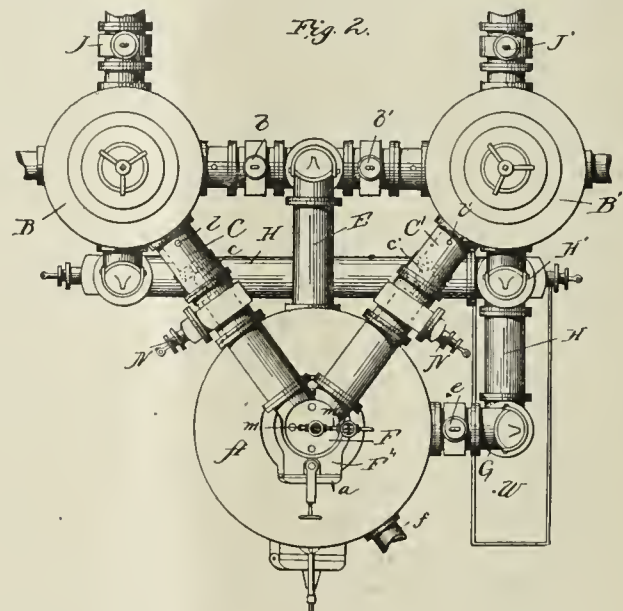

being the material ordinarily used. The cover of the generator is secured in place, and during the first part of the operation the covers of the superheaters are removed.

In this method of use of the apparatus the blast is passed up through the mass of coal, thence to the bottom of superheaters and up through the superheaters. For this purpose the valves *b b'* are opened. The valves *c c'* in the other lower pipes, the valves *d d'* in the pipes leading from the upper part of the superheaters, the valves *e e'*, and the valves *J J'* are closed. The valve of the blast pipe *f* is open, and the air is admitted at the bottom of the generator and to the combustion chambers *h h'*. The blast under the coal in the generator brings it to the incandescent condition. The products of combustion arising from the upper surface of the coal pass down through the pipe *D* and through its lateral branches through the combustion chambers *h h'*. Carbonic oxide and

the unconsumed carbon in these products meet in the chambers *hh'* an additional supply of air and undergo complete combustion, the products of which rise up through the refractory material and bring this material to a high heat, while the coal within the generator is coming to a condition of thorough incandescence. When the coal has reached this condition, the covers of the superheaters (if both are used) are secured in place, and the air supply is cut off from the bottom of the superheaters and the bottom of the generator. Then the valves *dd'* in the upper outlet pipes of the superheaters are opened and steam is admitted at the bottom of the generator. This steam passes up through the body of incandescent coal, and by its decomposition hydrogen is set free, while the

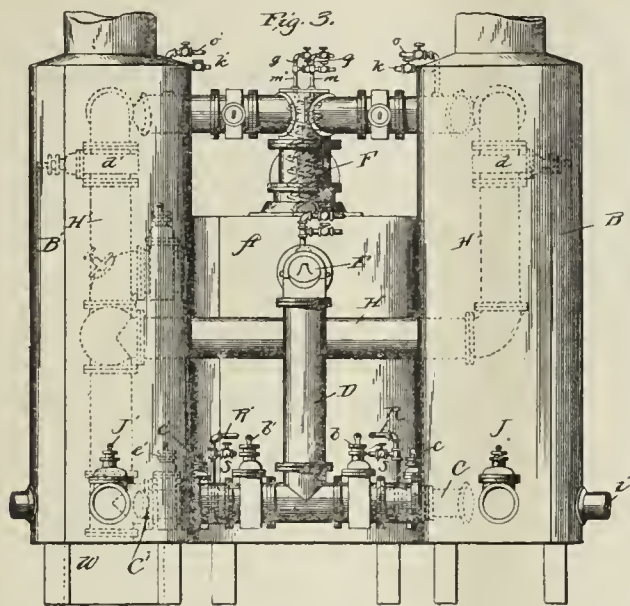

oxygen unites with the carbon monoxide and a small percentage of carbon dioxide.

If it be desired to manufacture illuminating gas, naphtha or other hydrocarbon liquid is admitted to the top of the generator through pipes heretofore described, and is vaporized by heat. This vapor is taken up by hydrogen arising from the surface of the coal, and the whole mixture passes through the pipes *ED* and their connections into the bottom of the superheaters. The superheaters act upon this mixture as fixing chambers, and the gas passes over them to the wash box of the purifying chamber.

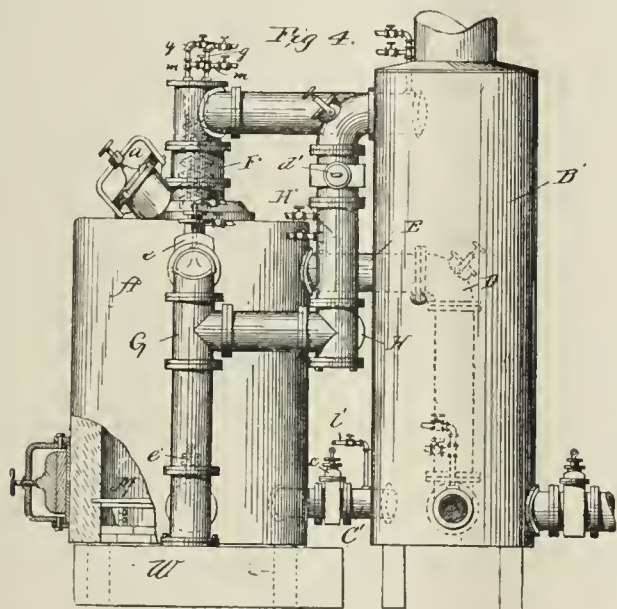

The construction of the apparatus is adapted to give still better results by another method of operation by which the quality of the gas is improved and a larger quantity obtained from the supply of coal. As in the method last referred to, the coal in the generator is brought to a proper incandescence, as heretofore explained. The blast from the pipe *f* is then shut off and the tops of the superheaters secured in place. The valves *bb'*, *dd'*, *NN'* and *JJ'* are closed. The valve *e* in the outlet pipe from the top of the generator and the valves *cc'* in the connecting pipes between the bottom of the generator and the bottom of the superheaters are opened. The steam is wholly shut off elsewhere, but is admitted to the top of the superheaters *BB'* through the pipes *kk'* and passes through the highly heated refractory material contained in the superheaters, where it is brought to a highly superheated and attenuated condition. It is then admitted through the pipes *CC'* into the bot-

tom of the generator, and in this dry and heated state steam is brought more readily into contact with the heated coal, and is more thoroughly decomposed. Hydrogen gas thus generated passes from the top of the generator through the opening at the valve *e*, thence down into the pipe *G*, and thence directly down into the wash box. If it be desired to have it take up hydrocarbon vapor in its passage, this vapor may be supplied by hydrocarbon pipes *t*, which, with the steam pipe *t'*, is located in the passage above the pipe *G*.

After this process has been continued for a time, the length of which may be easily determined by an operator skilled in the art to which the invention appertains, the point where the steam is admitted is changed. The valves *dd'*, *bb'*, *cc'*, and *e* are closed, and the valves *NN'* are opened, as is also *e'*. Steam is then admitted to the bottom of the superheater through the pipes *SS'*, and the steam is thus brought in its passage in contact with the first heated refractory material, which is in the bottom of the superheater, and is brought to a highly superheated and attenuated condition. In this condition it passes through the openings at the valves *NN'*, and thence through the connection in the casting *F'* into the upper part of the generator, where it comes in contact with a fresh surface of coal and passes downward through the mass, where it is decomposed as it expands. The resultant hydrocarbon gas passes through the valve *e'* at the bottom of the generator into the pipe *G*, and thence directly to the wash box.

If desirable, when the current is in one direction naphtha may be introduced at *RR'*, and in the other at *mm'*. In the manner above described the apparatus may be worked at a single heat repeatedly in opposite directions, the change in direction of the current being made as many times as desired; and if the supply of coal is exhausted it may be renewed and brought to a proper condition, as before explained. The apparatus is capable also of use in accordance with another method, which is specially adapted to the manufacture of illuminating gases. By this method, after the requisite heat has been obtained, as heretofore described, the valves *JJ' b d e e' c'* are closed, and the valves *cd' b'* are opened. Steam is admitted at the top of the superheaters *B*, and, passing down through the heated material therein to the bottom of the generator, enters through the pipe *C* in a superheated state. It then passes up through the incandescent coal and is converted into hydrogen gas. Rising from the coal in the top of the generator, it meets a hydrocarbon vapor from the coils in the casting *F*. This vapor is taken up by the hydrogen, and the whole then passes to the bottom of the superheater *B'* and as it ascends through the highly heated material therein it becomes thoroughly mixed and fixed, and then passes to the wash box. After the operation is continued in the manner above described for a sufficient length of time, which may be determined by an operator skilled in the art, the valves *n J'* are opened and the valves *d' b'* are closed. Steam and oil are admitted as before; but the gas resulting from the operation in other respects, as before described, passes through the valve *N'* into the top of the superheater *B'*, whereby the gas is brought into a fresh heating surface of the refractory material, passing down through the same and out at the valve *J'*, and through pipe (not shown) to wash box. It will also be apparent that the direction of the steam may be reversed in the above operation by closing the valves *J, J', d', b', e, e', and c*, and leaving *c', d* and *b* opened. Steam is then admitted at the top of the superheater *B'*, and passing downward, as before described, is superheated, and may be thence taken to the generator, where it is converted into hydrogen gas. The course of the steam may again be reversed by opening the valves *n' J* and closing *d* and *b*. The steam may also be made to pass downward through the coal and from *d' to b'* to the connecting pipes *CC'*, and steam pipes *ll'* on top of connecting pipes *CC'* are for the purpose of letting in a supply of steam to the hydrogen gas in case it should be hot enough to take up more steam and convert it into hydrogen.

Portable Photometer for Electric Lights.

The *Western Electrician*, in describing a portable photometer constructed by Queen & Co., of Philadelphia, says that to meet the demand created by the rapid adoption of the electric light for town and city lighting, and consequent necessity of making frequent tests for the purpose of conforming to certain standard conditions, the form of Bunsen photometer, shown in the cut, has been designed. The instrument is made especially for street work. The photometer is well made and exceedingly compact. It is 5½ inches square in cross section, and 38 inches in length, and is made of polished cherry. The lantern, as shown in the cut, slips into one end of the box, where it is firmly held; a small adjustable holder carries the standard light, which may be either one or two standard candles. This adjustment regulates the heights at which

the flame stands, and also its distance from the screen; by making this latter distance exactly one foot, computation is greatly facilitated. Distances are measured by a graduated bar which slides in grooves along the side of the box. To allow for the difference in vision between the right and the left eye, the instrument is made reversible—*i. e.*, it may be turned completely over, so that the right eye observes the side of the disc before observed by the left, and *vice versa*.

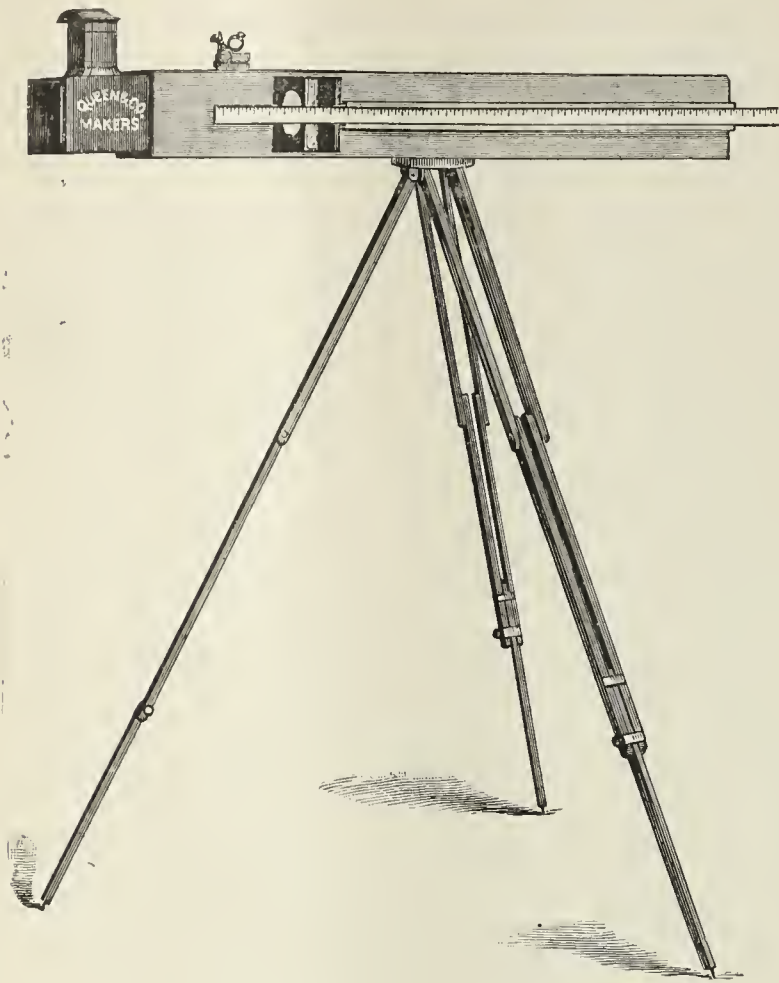

When not in use the lantern chimney slips out and can be placed inside the lantern itself. The entire lantern box may be pushed inside the photometer, and the two ends and the sight hole of the instrument may be covered with small slides. A brass handle on one side makes it possible to carry the instrument as easily as a small hand bag. If desirable, a small incandescent lamp may be used as a standard instead of the candles. The range of the instrument is from about 4 candle power up. It has already been very successfully used in several tests involving expert opinions.

The Poetsch System of Excavating.

By Mr. E. L. ABBOTT.

A series of vertical pipes are put down into the rock, or into material impervious to water. These pipes are arranged around the space in which the excavation is to be made, and are closed at the lower ends. There is in each an inner pipe open at its lower end and extending nearly to the bottom of the outer.

Through these pipes a cold fluid is circulated by means of a pump; this absorbs the heat from the surrounding earth and freezes it as hard as sandstone rock, most effectually cutting off the water. Then the excavation can be readily made without any trouble from water or flowing ground. Quicksand, when deprived of its water, is an easily worked material. The best arrangement of pipes is in a circular form, so that the frozen wall will be arched against the pressure. The practice has been to use pipes 8 inches in diameter and about 3 feet apart. The crushing strength of frozen quicksand has been determined to be from 700 to 1,000 pounds per square inch. The pressure from without, due to the weight of quicksand, cannot be known closely, as the mobility of the material is not known in advance. The assumption can be made that the pressure will be somewhere between that due to the weight of the water and the weight of sand and water combined, considered as a fluid. For safety the latter assumption should be made.

Experiments are yet lacking and needed to show what is the actual heat conducting capacity of saturated soils. It is known that there is generally a current of water percolating and flowing through ground saturated with water; this current keeps taking away the cold from the

pipes, and an excess must be constantly supplied, and the circulation of cold brine kept up throughout the time that the frozen wall is needed.

Refrigerating machines of the common types depend upon the principle, that when a gas is compressed its temperature rises, and conversely when it is allowed to expand its temperature falls.

Ammonia is found to be the most economical gas to operate with on account of its high specific heat.

There are several types of machines. In the compression type the ammonia is compressed mechanically, and in the absorption type it is compressed by the tension of its own vapor heated in a still, which still communicates with a coil of pipes immersed in cool, fresh water, which gives a fluid cooled to approximately the temperature of the cooling water, say, 60° F., while remaining at the pressure of the gas within the still.

In either type of machine the compressed gas is cooled in the same way, and is then allowed to expand through other coils, when its temperature immediately falls to a point far below zero. This gives the refrigerating effect of the machine, and the very cold gas may be circulated directly where the cooling is desired, or may be made to cool brine, which is more convenient to use as the circulating medium.

The actual efficiency of refrigerating machinery, as now made, and working between the limits usual in practice, is not over 25 per cent. of the energy applied.

The mechanical equivalent of changing the temperature of a pound of water one degree is 772 foot pounds, or one horse power per day of 24 hours is equivalent to changing 61,554 pounds of water 1° F. Taking a pound of water at 60° F., there are required 28 thermal units to reduce it to the freezing point, and then 142 more to freeze it, or 170 thermal units in all. Theoretically, then, one horse power per day would freeze 362 pounds.

In quicksand, where only a fraction is water, and the remainder having a specific heat of only one-fifth as much as water, the same refrigerating effect which would freeze a cubic yard of water will freeze, say, 2½ cubic yards of quicksand.

The first application of the process in this country was at Iron Mountain, Mich., where a shaft 15 feet square was sunk about 100 feet to the rock ledge through water-bearing strata. The site is a valley filled with glacial drift. The shaft is for pumping and hoisting from the Chapin mine, the owners being the largest producers of Bessemer ore in the Menominee district. Twenty-seven 8-inch freezing pipes were arranged in a circle of 29 feet diameter. An ammonia ice machine of the compression type was used, its capacity being 25 tons of ice, or 50 tons refrigerating capacity per day. The wall was frozen and the excavation made to the ledge in 2½ months from the time the ice machine first started. On starting the machine the earth commenced to freeze in the form of cylinders surrounding each pipe. In 10 days these cylinders were in contact, forming the frozen walls. From that time the freezing advanced within much faster than without the circle, for the reason that no heat could be conducted to the center by the surrounding mass, and also the currents, or percolations, of water through the sand could no longer warm the earth within the circle.

The unfrozen center became narrower as the excavation proceeded, requiring much difficult labor in loosening the frozen material. It was not considered wise to discontinue freezing, as trouble was anticipated at the ledge on account of springs or leaks coming in through the rock, and later developments justified this idea. Those strata of earth containing much water were frozen to much less distance than those containing little water.

Boulders were met with at different points. They were so firmly imbedded in the frozen mass that they had to be broken in pieces in order to remove them. It is proposed in the future to put in thawing pipes as well as freezing pipes, in order to thaw any excess of frozen material to facilitate excavation. When the excavation was approaching the ledge it became evident there was a leak, either in the ice wall or through the rock. There was an inflow of water requiring frequent bailing to keep it clear. About the time the rock was reached the leak had thawed a channel at the rock line so as to allow such a stream of sand and water to enter as to necessitate flooding the mine until the leak could be frozen off; but on pumping out the water other springs through the seamed and shaly rock showed themselves, and it was necessary to lay freezing pipes against the surface of the ledge and again flood the shaft and freeze a considerable part of the rock surface itself before the excavation into the sound rock could be completed and the timbering built in. This trouble would probably have been avoided if the freezing pipes had gone a few feet into the rock instead of only to it. In the case of a shaft now being built at Wyoming, Pa., the pipes are sunk 6 feet into the rock. In putting the pipes down it is of great importance that they be truly

vertical, so there will be no wide spaces between pipes at the ledge, where there is the greatest necessity for a perfect wall; also, the pipes must be absolutely tight, or the circulating brine will escape, and as it cannot be frozen it will keep the earth thawed near the leak.

In order to sink a pipe it must, of course, be open at the bottom, as various tools must be worked inside of it. A perfect closure of the bottom then cannot be made, therefore in practice a 10-inch casing pipe is put down the required depth, and then an 8 inch freezing pipe is placed inside, having its bottom perfectly closed by welding. The circulating fluid from the ice machine is a brine made with calcium chloride, which has the advantage of a very low freezing point together with a high specific heat, and also is nearly neutral in its character and does not corrode the iron pipes. It is circulated by pumping down an inner pipe and returning by way of the main freezing tank to be again cooled. The best results are obtained from such a rate of circulation that there is but little difference in temperature between the outgoing and incoming brine. A very efficient temperature for the outgoing brine is 10° below zero, F., and pumped at such a rate that the return flow is 2° higher.

The capacity of an ice machine varies as the temperature at which it is made to work. Its theoretical efficiency will be very much greater when worked at 20° above zero than when worked at 20° below, but at the extreme low temperature the conduction of the cold from the pipes through the earth is greater, so there must be a compromise made between theoretical efficiency of the machine and actual conducting efficiency of the ground. Sufficient experience has not been obtained to give a close idea of what this temperature should be.

Of all kinds of work for which the skill of the engineer is called into requisition, that of making excavations in earth, where a head of water is to be resisted, is conceded to be the most troublesome.

The name quicksand is given to any earth which, when mixed with water, will in some degree run like a fluid. Almost any sand, when mixed with a small amount of clay, will exhibit this faculty. The most troublesome kind has but a small percentage of sand and that very fine; the material being principally disintegrated soft rock. When rubbed between the fingers scarcely any grit can be felt. This material, when undisturbed, may have some consistency, but when once broken will flow with water through any minute opening. Its particles are so small and their specific gravity so light that they will float in the current of water to any distance, so long as the velocity of the water is kept up.

In excavations in running ground the great difficulty is not so much in keeping the water out as in preventing damage from quicksand shifting in its bed, which is likely when water is pumped from the excavation, as it destroys the equilibrium of the mass. In the case of deep excavation, like shaft work, it will bring an unequal or bending pressure on the walls of the shaft, which destroys its alignment or ruptures the shaft entirely.

In the development of the resources of any country, it is obvious that the nearest and most easily worked deposits will be opened up first, and similarly in all constructions for first internal improvements, easy and temporary expedients will be recommended as giving immediate results. That period of construction has already passed in this country.

The freezing process comes in its proper time to assist in some work urgently needed.

Deeper and better foundations are needed for bridges which will cross the great alluvial rivers, as the lower Mississippi. Tunnels are required under rivers where the importance of navigation must prohibit bridges, as across the Hudson at New York. The development of a good portion of the anthracite coal fields of Pennsylvania is yet to be accomplished, which the overlying quicksand has, until now, prevented.

In the kinds of work mentioned, the pneumatic process has been very valuable, but the depth at which it can well be used without causing loss of life or health is not great, and the freezing process is the only reliable method of penetrating water-bearing earth to the depths to which it is necessary to go to carry out many great works which the further development of our resources and commerce now demand.

Carcass Roofing.

By Mr. J. ROBINSON.

In small buildings all the rafters are of one kind; but in great buildings the whole weight of the covering is made to rest on a few principal rafters, which are connected by beams placed horizontally, and either mortised into them or scarfed on them. These are called purlins. Small rafters are laid from purlin to purlin, and on these the laths for tiles or the skirting boards for slates are nailed. Thus the covering does not immediately rest on the principal frames. This allows some more liberty in their construction, because the garrets can be so divided that

the principal rafters shall be in the partitions, and the rest left unencumbered. This construction is so far analogous to that of floors which are constructed with girders, binding and bridging joists. It may appear presuming in us to question the propriety of this practice. There are situations in which it is unavoidable, as in the roofs of churches, which can be allowed to rest on some pillars. In other situations, where partition walls intervene at a distance not too great for a stout purlin, no principal rafters are necessary, and the whole may be roofed with short rafters of very slender scantling. But in a great uniform roof, which has no intermediate supports, it requires at least some reasons for preferring this method of carcass roofing to the simple method of making all the rafters alike. The method of carcass roofing requires the selection of the greatest logs of timber, which are seldom of equal strength and soundness with thinner rafters. In these the outside planks can be taken off, and the best part alone worked up. It also exposes to all the defects of workmanship in the mortising of purlins, and the weakening of the rafters by this very mortising; and it brings an additional load of purlins and short rafters.

A roof thus constructed may surely be compared with a floor of similar construction. Here there is not a shadow of doubt that if the girders were sawed into planks, and these planks laid as joists sufficiently near for carrying the flooring boards, they will have the same strength as before, except so much as is taken out of the timber by the saw. This will not amount to one tenth part of the timber in the binding, bridging, and ceiling joists, which are an additional load, and all the mortises and other joinings are so many diminutions of the strength of the girders; and as no part of a carpenter's work requires more skill and accuracy of execution, we are exposed to many chances of imperfection. But, not to rest on these considerations, however reasonable they may appear, we shall relate an experiment made by one on whose judgment and exactness we can depend. Two models of floors were made, 18 inches square, of the finest uniform deal, which had been long seasoned. The one consisted of simple joists, and the other was framed with girders, binding, bridging, and ceiling joists. The plain joists of the one contained the same quantity of timber with the girders alone of the other, and both were made by a most accurate workman. They were placed in wooden trunks 18 inches square within, and rested on a strong projection on the inside. Small shot were gradually poured in upon the floors, so as to spread uniformly over them. The plain joisted floor broke down with 487 pounds, and the carcass floor with 327. The first broke without giving any warning, and the other gave a violent crack when 294 pounds had been poured in. A trial had been made before, and the loads were 341 and 482; but the models having been made by a less accurate hand, it was not thought a fair specimen of the strength which might be given to a carcass floor. The only argument of weight which we can recollect in favor of the compound construction of roofs is that the plain method would prodigiously increase the quantity of work, would admit nothing but long timber, which would greatly add to the expense, and would make the garrets a mere thicket of planks. We admit this in its full force; but we continue to be of the opinion that plain roofs are greatly superior in point of strength, and therefore should be adopted in cases where the main difficulty is to insure this necessary circumstance.

Dangers of Gas and Geyser Baths.

[Read by Mr. Arthur F. Chapple, before the Balloon Society of Great Britain.]

In asking for your indulgence and forbearance during the very few observations that I have the pleasure of addressing to you this evening, I may state that I am not going to attempt to deal with this subject in a scientific manner, for the simple reason that it is closely allied to chemistry and gas engineering, neither of which fields includes me as a student; but my object is, from my own sad experience and the experience of others, to raise some interest in the matter that shall eventuate through the able co-operation of the press, and those who have to do with the framing of our laws, in bringing about some enactment that shall enforce on all makers of gas apparatus (especially such contrivances as gas and geyser baths) the obligation of not issuing these machines to the public without certain safeguards, so as to avoid such dire calamities as those with which it has been my misfortune to be made familiar.

I regret for some reasons that you have not one here in my place to entertain you with some scientific or other matter of general interest, such as you have so often discussed in this room. In the place of that you have before you a member of only a week old, who having lately heard of several sad fatalities due to gas and geyser baths that happened

prior to his own great loss, and as many as two since last September, feels that he may venture to accept the kind invitation of your President to lay these few remarks on this special subject before you for your consideration, and in doing so I will ask you to regard it more as a text or of a peg on which to hang your consideration and discussion rather than that you should expect at my hands anything like an exhaustive treatment of the subject of this little paper which I have only very hastily prepared.

I have said that I regret the subject is not one of more general interest, for the number of persons using gas and geyser baths is, of course, comparatively small, though the number of itself is very large. I feel, therefore, that I can claim *some* interest at your hands inasmuch as the matter involves the safety of human life, but the possibility of death resulting from any act of our everyday life is not generally a welcome subject, and I suppose no question so keenly arouses general interest as those which affect the pocket! Only start a question of £ s. d., and you are sure of the popularity of your subject, or raise some cry against law and order, or allege some grievance, real or imaginary, and Hyde Park itself will be required to hold your audience.

I take it for granted that all present know something of the construction of gas and geyser baths, but as I have lately met with some who do not quite understand the difference between them, I will very briefly explain, for the benefit of any such, that a gas bath is an ordinary bath, heated by a series of burners underneath it, the water in the bath gradually increasing in temperature until it attains the required heat. A geyser bath, on the contrary, is an ordinary bath, with a geyser affixed to it, the geyser being a kind of urn and generally standing on the edge of the bath, and into which the cold water from the main runs over plates heated by a series of gas burners, which are contained in itself, and then runs out at the other side into the bath at a given uniform heat.

Without further preface I will now give you the benefit of my sad experience, in the hope that should it ever be your lot to have to do with gas or geyser baths, you will at least be forewarned. Had I been so forewarned by the experience of my predecessors in this direction, the probability is that my family would have been spared the affliction of losing, in his 21st year, one of the finest and noblest of sons, and one, too, as clever as he was good.

Last September I removed from a house where I had the ordinary hot water pipes for supplying the hot water to the bath, to a house which had no such hot water apparatus, and to supply this lost convenience a geyser was fitted up in the bath-room at the suggestion of the landlord. Now, I am not going to lay this particular geyser to the charge of any special maker, for though I have reasons for believing who the maker was, no name was stamped upon it. Nor is it necessary for me to particularize any special make of geyser as being especially dangerous, for the experience of others has taught me that those made by the best makers, as well as the most remote, are alike open to the same danger, in the absence of *special* precautions. With those precautions I admit that gas baths and geysers are convenient and perhaps desirable things, but until the necessity for those precautions is brought prominently before the eyes of those who use these machines, so long will fatalities continue to happen.

In my case, my son went to the bath-room to take his first bath there, at 8:30 on Sunday morning, the 22d of September. His continued absence causing surprise the door was tried and knocked at without response. An alarm was at once raised, and the door broken open, but only to find that we were too late, for he was under the water, dead. The gas was still burning and the water slowly flowing. The room was small and without special means of ventilation. This getting into the bath while the gas is burning has been the fatal step in those cases which have since come to my knowledge, as well as in this case. But who, lacking the combined knowledge of a chemist and gas engineer, is to know that if he enters the bath under such conditions he will never come out alive. I shall be supported, I believe, by our Chairman when I say that these oxide of carbon fumes generated by the atmospheric or bunsen burners of these appliances are so deadly that a thousandth part in the air will destroy life, and so heavy that immediately they cool on leaving the apparatus they fall to the ground, and so pour down over and surround the head of the victim, depriving him of the consciousness of knowing that he must get fresh air at once or die in a few minutes. This deadly gas, while acting on the brain and depriving the victim of consciousness, closes the air cells of the lungs, and kills the blood, in the sense that it paralyzes those ever-changing conditions which are kept in constant activity throughout life by the vitalizing property of oxygen contained in pure air.

I do not profess to be in any sense an expert on this subject even now,

but this great calamity naturally made me inquire with keen interest into the manner in which death was brought about. I then heard that my experience was by no means an isolated one—that a few years since the librarian at the free library at Anerley lost his life in the same manner also by a geyser, and Miss Cooke, the daughter of the well-known tourist, lost her life by a gas bath. I have also heard of several instances where help has been happily forthcoming in time, and the worst averted. I did what I could at the time to make my case known, and I have to thank the *Times* and *Globe* and some other high-class journals for the very valuable and kind assistance which they afforded me in this direction. But, unfortunately, this was not sufficient to avert the two other cases I have referred to, which have recently been brought to my notice, and hence my determination to endeavor still further to make this danger known. The press has again kindly assisted me. How many other cases may have happened that I have not heard of it is impossible to say. The first of these two last named cases occurred at Chelsea, on the 15th of March last, when a young married lady lost her life in precisely the same manner as my son, the maker of the geyser in this case being one of the best known. Two days after, namely, on the 17th of March, a youth lost his life at Haverstock Hill, also under exactly similar circumstances, and by a geyser by one of the best makers. He was an only son in his 16th year. I have been and now am in personal communication with those unhappy people, and am therefore in possession of all particulars.

It may now interest you to know the result of some experiments which I subsequently made in the presence of the doctor who was called in and pronounced my son dead. I lit the geyser and turned on the water, regulating the supply of gas and water to the same volume, as far as I could judge, that I found prevailing on the fatal morning. I then placed a lighted candle on the side of the bath, at the same level as the head of an adult would be while in the bath; I then shut the door of the bath-room, and reopened it in ten minutes. The candle was burning very dimly, but, of course, immediately revived on the admission of fresh air. I then turned off the gas and water and cleared the room of the fumes, and repeated the experiment, and opened the door at the end of 20 minutes. The candle was out, and from the appearance of the composition of the candle it had been out several minutes. I made a subsequent experiment, and on looking under the door and seeing no light I opened it at the end of seventeen minutes, and the candle was out. I thus infer that the candle would not burn under those conditions much beyond 12 or 15 minutes, which, of course, means the extinguishment of life in about the same time. I then repeated the experiment with one inch of the window open at the top, and on opening the door I found the candle was burning brightly at the end of 20 minutes, and it would no doubt have continued to do so as long as there was anything to burn.

I shall doubtless be met by the friends of the appliances with the observation that if the room is small, as it was in my case, and generally is, the window should be kept wide open while the bath is filling, and the gas and water in any case to be turned out before entering the bath.

All that I fully admit, and that is all I desire to be impressed on the public, and with that view I addressed a letter to the *Globe*, on the 14th of April last, in reply to one from Messrs. Ewart, gas engineers, who, commenting on a previous letter of mine, advocated the necessity for the enforcement of some regulations for the use of geysers, but they said that they would suggest that no apparatus should be fitted in a room containing less than 1,000 cubic feet of air, without a ventilating shaft. Now this to my mind, is only creating fresh complications, which may or may not be regarded by the person who fits up the apparatus, and further accidents will inevitably occur. I do not advise anyone to trust to ventilating shafts, or anything apart from the simple and special precautions which I advocate, for it is only when we trust to those things that are not within our immediate control, that the unexpected happens. At the inquests that are held on those who have been so needlessly sacrificed, we are simply comforted by the most elementary statement, that the apparatus would have been perfectly safe with proper ventilation. As well might we be told that dynamite is perfectly safe in the absence of friction or concussion, or that a loaded revolver, at full cock, in the hands of a child, is safe so long as the trigger is not touched. I therefore suggested in that letter to the *Globe*, that every manufacturer should be compelled to stamp into the metal of every apparatus of the kind a caution to the following effect, "Caution! The bath must be filled while the room is being ventilated, and before closing the door. When filled turn off gas and water. The bath must on no account be entered until this is done."

Why is it that a simple *modus operandi* of this kind should be objected to and contested? I trust that the motive is not so worthless as the fear of raising an alarm in the minds of the public, and thus injur-

ing the sale of gas and geyser baths, but I must say it has that appearance. I suggest that fatalities of the kind I have described occurring from time to time, hushed up as they may be, for the sake of trade interests, will eventually do more to shorten the life of the gas and geyser baths, than the stamping of such precautions upon them, and no such accidents being known. The publication of these disasters not having proved sufficient, I submit the time has now come, when the Legislature should take the matter up, and compel the enforcement of such precautions as I have suggested being stamped on these machines by the makers, and that its omission should constitute a penal offence, and with that view I hope still to work in this cause.

I am not here in any vindictive feeling against those who make these contrivances. I do not say they are one and all abominations, and should be suppressed, but I simply advocate the importance of necessary caution, nor do I find fault with the law for not having already interfered, but I do say that the time has now come when action is demanded, and when unsuspecting persons ignorant of the nature of these machines should be put on their guard before using them, and not be snared into deathly traps and cheated out of their lives for fear of exhibiting a notice that some might think would alarm the public and so injure the trade. The law is the guardian of the people, and this is no fancied or imaginary danger, that exists in so many of our homes. Unhappily, the danger has proved too real, and seeing how mindful the law is of things of far less value than human life, I do not despair of getting this important subject taken up by Parliament. Apart from this matter, there are many pressing things waiting for legislation, and I say nothing disrespectful to the law (for I hope I am far too conservative and constitutional in my views to do that) when I say that much useful law making is hindered by individuals in the House who will talk of nothing else but education, the Irish question, and the grievances of the working man—all excellent things in their way, and well deserving of a nation's care, but these poor worn out hobby horses, should now, I think, be allowed a little rest, while others are trotted out for exercise. It is right that trade and invention should be encouraged, but where human life is at stake, then the law should see that those who reap the harvest should not do so without due regard to safety.

I said at the commencement of my remarks that they would necessarily be very brief, and I have now little more to add. I wish it to be understood that it was not my intention from the first, nor have I attempted to discuss this question from a scientific point of view. Had I done so, and had been competent to fulfil the task, I have no doubt a very elaborate address could have been written, but my object, I trust, has been served as far as this evening is concerned. I could have wished that my audience had been composed of thousands, and I trust my feeble utterances may, by the good offices of the Press, extend beyond the limits of this room. I am already indebted, as I have before said, to the Press, for similar good services, for by its valuable agency, my voice of warning last September was heard far and wide, throughout the civilized world, and its echo has not yet passed away.

I will only add that there is a period in all human events when ignorance ceases and responsibility steps in by reason of acquired experience and knowledge. That period, to my mind, has now arrived in this matter with the makers of these contrivances, and I will go so far as to say also with the Legislature, for if the Legislature willfully disregards (after being informed of the danger) so simple a proposal, having for its object the effective protection of human life, then for every life, that may be lost, that responsibility will be theirs. Precautions are rightly taken by the law to regulate the sale of poisonous drugs and explosives; and why? Because they involve danger to human life. And so with gas and geyser baths the danger is self-evident.

I have just spoken of responsibility resting upon manufacturers and upon the law. I venture humbly to think that a like responsibility is imposed upon me, and all who have suffered the cruel sacrifice of a most valuable and beloved life, and that it is not enough to settle down under one's own trouble, without regard to others who may meet a similar enemy in the dark unarmed. By your kind co-operation and indulgence, I feel I have to some extent discharged that responsibility, and should it ultimately result in removing this existing evil, then our time will have been well spent, for it will inevitably be the means of saving precious lives. If, on the other hand, I have to let the thread drop almost where I took it up, but it results even in the saving of one life, who can say how great the price of that life may be to his or her belongings, and even to society at large?

THE miners of the New York and Cleveland Gas Coal Company are persisting in their demand for the institution at these collieries of the Columbus wage scale—79 cents per ton.

SPECIAL ENGLISH CORRESPONDENCE.

COMMUNICATED BY NORTON H. HUMPHRYS.

SALISBURY, May 10, 1890.

Enterprise in Gas Supply.—Gas and Ventilation.—Yeadon's Improved Retort.

The present is a stirring time for gas suppliers, yet amid all the wild talk about competition, the waving of petroleum lamps and the flashing of electric lights that we all experience, it is remarkable that a sure and immediate reward appears to await anything in the way of a little judicious enterprise in connection with the supply of gas. It is interesting to notice how our industry is gradually leaving the slow and stately step that it formerly arrogated to itself, and is being gradually drawn into the rushing round of ordinary business operations. There is every sign that this must increase with more and more rapidity. While electric light people are rushing here, there and everywhere, ready to take orders on almost the consumers' own terms, and others are willing, not exactly to give new lamps for old ones, like the magician in Aladdin, but to bring around lamps at regular periods, ready trimmed and replenished with petroleum, thus saving the householder the trouble and risk of carrying out that operation on his own premises, gas people cannot afford to sit in their offices and wait for customers to come in.

The Paris Gas Company have experienced a large increase in the consumption of gas during the past year. A fact, considering that they supply ordinary—very ordinary—quality gas at about \$1.50 per 1,000 cubic feet, which is very remarkable. The shareholders in the Paris Gas Company appear to be the "upper dog" (I have learned that simile from reading the transactions of American Gas Light Association) in this business, as they get a dividend of something over 30 per cent. A large number of houses in Paris are let out in flats, and the visitors to the gay city last year, who were puzzled by the little placards containing the words *gaz a tons etages*, that seemed to be rather plentifully bestowed about the streets on the fronts of houses, will find the explanation in the report of the Paris Gas Company, which sets forth that they have introduced the plan of laying a rising pipe, to bring the gas to each floor, at their own expense. No less than 2,400 such services were laid during 1889, and the Company now have over 100,000 consumers amongst the dwellers in flats. Rather more than one-fourth of the total number of houses in Paris are supplied in this way. It is also noticeable that the Gas Company average about two consumers for each house in the city, *i. e.*, that there are twice as many gas consumers in Paris as there are houses. The Company have an excellent day consumption, amounting to 26 per cent. of the whole. The city of Brussels, selling gas at about half the price, and for purposes other than lighting at one-third the price, fail to record such good results at present, although their day consumption is increasing so rapidly as to warrant the expectation that an equally satisfactory record will soon be reached. It is to be regretted that so few of our English gas undertakings publish any record of their day consumption. In many cases, looking at the number of stoves and engines in use, this cannot be far short of 30 per cent. of the whole. In small residential towns, where gas is sold at a moderate figure, it is easy to reach 20 per cent. or more of the total, by adopting the well tried means of extending day consumption, such as the supply of cooking stoves on hire, a moderate discount on gas engines in continual use, etc.

Some correspondence that has lately appeared in the *Times* (the principal English daily newspaper) furnishes a sad commentary on the ignorance of gas consumers as to the important subject of ventilation in connection with the use of gas, and also of a want of knowledge in that direction on the part of some persons who undertake the fixing of gas apparatus. The former have a greater claim on our sympathy than the latter, as if one employs a tradesman to supply and fix any apparatus, whether for gas or anything else, it is scarcely too much to expect that he should look for specific instructions that will enable him to use the appliance, of course assuming reasonable care and intelligence in such use, with safety both to life and property, from the person who supplies it. A Mr. Chapple writes to say that he had an apparatus for heating water rapidly fixed in connection with a bath, and that his eldest son was suffocated from the fumes of the gas burnt.* He has also heard of two other fatalities under similar circumstances. He therefore suggests that some member of Parliament should bring forward a measure making it a penal offence for a maker to sell such apparatus without full instructions as to use and mode of ventilating, etc., stamped on the iron-work of the machine, and that the same should not be fixed except by accredited agents. Looking at the large extent to which gas is applied, for so many different purposes, it seems almost absurd that any fairly

* See JOURNAL, p. 735.

educated person should be unaware of the fact that large quantities of gas cannot be used without producing their equivalent of carbonic acid and water, and that these products must be removed from the apartment in which they are produced; or that every gas burner requires a continual supply of fresh air proportioned to the quantity of gas used. It is stated, moreover, that in one of the fatal cases the apparatus had been fixed by a gas company; so it is not only gasfitters who appear to be in need of a full acquaintance with the laws attending the combustion of gas. Large quantities of water cannot be rapidly heated except by the combustion of a large quantity of gas in a short time, and one can readily perceive that if an apparatus for this purpose is fixed in a small, badly ventilated room, such as bath rooms in private houses usually are, there is a great risk of danger to health, and even to life. The only really safe plan is to cut the apparatus off from the air of the room by providing it with an independent air supply from outside, and a flue to take off the products of combustion. Even if a flue pipe connected to a good uptake is provided, it cannot be relied upon unless there is also an adequate fresh air inlet.

A well-known firm that makes the manufacture of rapid bath heaters a specialty agrees that mere publicity is not sufficient to prevent accidents from want of ventilation, and suggests that no apparatus burning more than a given consumption per hour should be fixed in rooms under certain dimensions without the employment of proper ventilating pipes. For instance, they suggest that a burner consuming more than 30 cubic feet of gas per hour should not be fixed in a room having less than 1,000 cu. ft. cubical capacity without proper ventilation. The root of the evil is want of ventilation. If a room is so badly provided for, or rather not provided for at all in this respect, as shown by the fact that the combustion of a few cubic feet of gas is sufficient to exhaust the life-sustaining properties of the air, it can scarcely be wholesome even if the gas is not used at all, and the consumption of gas is only a contributing cause, though possibly the principal one, to the fatal effect. It is only a question of time how soon the air becomes prejudicial to health by the emanations, and by the consumption of oxygen, on the part of the occupants of the room. If every apartment in a house was properly ventilated, according to the the known rules observed in hospitals, public buildings, etc., such accidents would not occur; but of course this is no palliation for the ignorance exhibited by those who fix such apparatus. The moral of the whole business, so far as gas companies and gasfitters are concerned, is not simply to order an apparatus from the maker, and then send a workman to fix it, possibly without ever seeing the appliance or the place where it is to be fixed, but to take care that its working is properly examined and tested by a competent person.

The increased cost of coal and wages appears to have had the effect of directing the attention of inventors towards the problem of effecting some labor saving improvement on the usual methods of heating coal in our retort houses. Amongst others, Messrs. Yeadon & Co., of Leeds, have taken up the problem of an automatic retort, by which I mean one that is continuously fed with a regular supply of coal, and that is continuously discharging coke, these operations being conducted without loss of gas and without admission of air to the retort. In this system the retort is a cylindrical conical shape, fastened to metal sockets at each end. It is fixed in a horizontal position in a furnace, and is so made that the sockets or rings project on each side and rest upon suitably disposed bearing rollers. This retort is made to revolve slowly by appropriate machinery. A number of projections or blades are arranged on the interior of the retort, which serve to stir up the charge during the act of revolving, exposing every part of it to contact with the red-hot surface of the retort. The coal, which may be small, slack, or even dust, is admitted at the small end of the retort, and the coke passes out at the large end into a chamber with a slide at the bottom, and from which the gas education pipe is taken off. The slide can be opened to allow the coke to fall into another chamber below, and from this it can be delivered direct into the furnace, into barrows, or to the hoppers of conveying machinery, as may be desired. In this arrangement the whole of the retort, with the exception of the ends, is exposed to the furnace, and is therefore equally heated throughout. The ends, bearing rollers and actuating machinery are all outside the furnace, and therefore beyond the reach of a prejudicial degree of heat. Amongst the advantages claimed by the makers are the use of the cheapest kinds of coal, and the dispensing with labor; the conducting of all operations without leakage of gas or admission of air, that the plan of distilling coal in thin layers, with regular and constant turning and mixing secures a great improvement, both in regard to quality and quantity of gas, also that the latter is more uniform, as compared with ordinary ways of working; that carbon deposits or choked ascension pipes are prevented; that the retorts are not subjected to the injurious effects of variations in temperature,

and that their shape admits of withdrawal when worn out, and the replacing of new retorts without disturbing the brickwork of the furnace. If Messrs. Yeadon can show the realization of all these claims in practice, without any corresponding drawbacks, they have introduced a valuable invention that will be a great improvement, as avoiding many of the objectionable features incidental to the ordinary methods of distilling coal for the manufacture of gas. A Mr. Woodhouse has also patented an improved scoop capable of introducing the charge into the retort at one operation instead of two, as usually required with scoop charging, and of depositing the same evenly upon the floor of the retort.

The Opinion of the Attorney-General of Massachusetts in Respect to the Right of Cities and Towns to Operate Gas and Electric Light Plants.

In response to several inquiries we herewith republish the full text of the opinion of Attorney-General Waterman, of Massachusetts, in the matter of the right (under existing laws) of municipalities in that State to operate gas and electric light plants. The opinion is:

HOUSE...No. 444.

COMMONWEALTH OF MASSACHUSETTS,
ATTORNEY-GENERAL'S DEPARTMENT,
COMMONWEALTH BUILDING, BOSTON, April 30, 1890.

To the House of Representatives of Massachusetts, now in session:

I have the honor to reply to your order adopted on the 11th inst., and which was received by me on the 15th, requiring me to transmit to your honorable body my opinion, with reasons therefor, "as to whether, under the existing statutes, cities and towns have authority, first, to construct and maintain within their own limits and for their own use systems of lighting by gas or electricity; and second, whether in connection with such systems they may sell gas or electricity for private use in such towns or cities."

And in pursuance with the order I respectfully comply with your request, and herewith give you my opinion upon the questions of law submitted to me, with my reasons therefor.

A town, as known to our laws, is a municipal corporation having jurisdiction to act only within a defined locality, established for public purposes, and to administer local affairs of public concern, and so peculiar to the locality as not to be common to the State or people at large, and the general government of which is administered in town meetings by its qualified citizens in person, with powers generally inferior and subordinate to the power of the Legislature, by which its powers may be curtailed and even extinguished by division and annexation to other towns.

The primary or fundamental powers and duties of the towns of Massachusetts are limited to objects of government which directly affect the reasonable necessities and prudential affairs of the general welfare of its inhabitants, resting upon the fundamental basis of right and justice, which powers, in the absence of a constitutional provision, cannot be diverted from their natural political and public application to such general welfare; but new obligations and duties not before exercised may be imposed upon towns at the pleasure of the Legislature which are not of a private or commercial nature, or inconsistent with such general and primary powers, or which are incidental thereto, even against their consent.

Towns do not exist under any express provision of the constitution of the State. Their powers and duties became fixed and established upon a foundation and identity of government long before our present form of State government was adopted; which they obtained by long usage and prescription and by express provisions of law all combined, and which gave them an existence as if by an unwritten constitution subordinate to the legislative power of the State, and under its control when exercised in such a manner as not to interfere with such fundamental or primary powers.

Towns, upon general principle as municipal corporations, have no power to levy taxes and assess money upon the inhabitants for general or indefinite purposes, but only so far as the same may be necessary to enable them to exercise the powers, enjoy the privileges, and perform the duties established as before intimated.

The statute of 1785, chapter 75, entitled "An act for regulating towns, setting forth their powers and for the choice of town officers, and for repealing all laws heretofore made for that purpose," is the re-enactment of an earlier law. By section 7 thereof, general authority is given towns to raise money, etc., and it provides that they may "grant and vote such sum or sums of money as they shall judge necessary for the settlement, maintenance, and support of the ministry, schools, the poor, and other necessary charges arising within the same town," and makes provision concerning the prudential affairs of the town conducive

to the peace, welfare, and good order thereof; and by section 11 of the same act, all laws theretofore made for the purposes mentioned in the act were expressly repealed and annulled.

The enumeration in the statute of objects for which towns might raise money are there cited as instances of the authority to raise money for objects, the cost and expenses of which could be legally paid by the town, including those which fairly came within the terms "other necessary charges."

In the Revised Statutes enacted in 1836, and in the General Statutes enacted in 1860, and the Public Statutes enacted in 1882, the enumeration of the objects contained in the act of 1785 for which money might be raised and expended by towns, is substantially repeated, and also there is an enumeration of other objects of similar nature of those enumerated in the statute of 1785. There is also given by section 37 of chapter 27 of the Public Statutes authority to towns to authorize a village or district to be accurately defined within its limits and containing not less than one thousand inhabitants, to organize for the purpose of erecting and maintaining street lamps, etc., and by section 44 of the same chapter towns may construct lines of electric telegraph for its own use along its public ways, and may construct lines for the same use and in the same manner for the transmission of electricity for the purpose of lighting, all of which objects are of the same class which pertain to the public welfare and prudential affairs of the town, and are incidental to the primary and fundamental powers thereof under the present existing state of things. And I can find no law or statute by which towns have been authorized to enter into business of a commercial or private nature such as requires an investment of capital and the employment or particular application of skilled labor or scientific knowledge therein. And I am of the opinion, for the reasons above stated, that, under the existing statutes, towns have no authority to construct and maintain, within their own limits and for their own use, systems of lighting by gas or electricity; nor can they, in connection with such systems, sell gas or electricity for private use in such towns.

A city is a municipal government established by the Legislature under the power vested in it by authority of the second article of the amendments to the constitution of the Commonwealth adopted April 9, 1821, and which provides that:

The General Court shall have full power and authority to erect and constitute municipal or city governments in any corporate town or towns in this Commonwealth, and to grant to the inhabitants thereof such powers, privileges and immunities not repugnant to the constitution as the General Court shall deem necessary or expedient for the regulation and government thereof, and to prescribe the manner of calling and holding public meetings of the inhabitants in wards or otherwise for the election of officers under the constitution and the manner of returning the votes given at such meetings; *provided*, that no such government shall be erected or constituted in any town not containing twelve thousand inhabitants, nor unless it be with the consent and on the application of a majority of the inhabitants of such town present and voting thereon, pursuant to a vote at a meeting duly warned and holden for that purpose; and *provided, also*, that all by-laws made by such municipal or city government shall be subject at all times to be annulled by the General Court.

This constitutional provision does not authorize the granting of charters; it only authorizes the Legislature to establish municipal or city governments in town or towns containing at least 12,000 inhabitants, under a government more convenient in form and better adapted to a large number of people than the form of a town government; that is, an organization that will allow the inhabitants to meet in sections or precincts, for the purposes of election and choosing representatives, who can meet to deliberate instead of the whole body meeting in town meetings in person; not giving and not intending to give powers or privileges to the inhabitants of a city as citizens of the Commonwealth, greater than those enjoyed by inhabitants of towns, they both being municipal, local governments, only differing in the form of the administration of their affairs. In accordance with this construction the Legislature has provided in chapter 28, section 2, of the Public Statutes that—

Chapter 27 (which treats of the powers and duties of towns) and all other laws relating to towns, shall apply to cities so far as they are not inconsistent with the general or special provisions relating thereto; and cities shall be subject to the liabilities, and city councils shall have the powers, of towns.

And in chapter 3, section 3, clause "twenty-third" of the Public Statutes, it is provided that the word "town" may be construed to include cities. It therefore seems that cities and towns are subject in principle to the same laws, excepting the forms aforesaid; and I am of the opinion, for the reasons hereinbefore stated, that under the existing statutes

cities as well as towns have no authority to construct and maintain within their own limits and for their own use systems of lighting by gas or electricity, nor can they in connection with such systems sell gas or electricity for private use within their own limits.

ITEMS OF INTEREST FROM VARIOUS LOCALITIES.

THE Troy (N. Y.) Gas Company will lay a 12-inch main from the works on Hill street, through Fourth to Grand street. Piping times these, beyond a doubt.

WE understand that the Coney Island (N. Y.) Fuel Gas and Light Company has again changed hands. The new proprietors have elected Mr. W. S. Doren to the Presidency, and Mr. T. W. Rieddale has been elected Secretary and Treasurer.

THE property and franchises, etc., of the Mutual Gas Light Company, of Bay Shore, L. I., are to be sold at auction.

SECRETARY AND TREASURER WALKER, of the Helena (Mont.) Gas Light and Coke Company, notifies us that the offices of the Company have been removed to lower Main street, corner of Lawrence street.

ARTICLES have been filed by Messrs. Miles C. Moore, W. F. Newell, Geo. D. Shannon, Edward T. Young and Edmund Rice, for the incorporation of the Olympia (Wash.) Light and Power Company. The stated objects are: To furnish and supply water and natural gas to consumers for domestic, manufacturing or other purposes; to manufacture artificial gas, electricity or other agents which may be used for light or heat or as motive power; to transmit sound by wire charged with electricity; to purchase, build, construct, equip, maintain and operate railways; and to buy and sell personal and real property. Capital stock, \$500,000. Place of business, Olympia, Wash.

THE new rates for gas supplied by the Montreal (Canada) Gas Company, which became operative on May 1st, are: Gross, for ordinary purposes, \$1.60 per 1,000 cubic feet, with 20 cents per 1,000 off for prompt payment; for cooking, heating and power uses, \$1 per 1,000, net.

FROM a local source we have the following details respecting the last trial of the case entitled "The United Gas Improvement Company vs. The Manchester (N. H.) Gas Light Company," some account of which has already appeared in these columns: "The trial of this case in the United States Circuit Court at Portsmouth, N. H., before Judge Colt, has awakened not a little local interest, though not many outside the ranks of the interested parties understand the real import of its bearings. The suit is brought by the United Gas Improvement Company to recover what it claims are damages caused by the Manchester Gas Light Company three years ago, when the latter sold out to the Peoples Gas Light Company. It appears that before the Company sold out it had in contemplation the introduction of a water gas plant, and to this end was in consultation with various manufacturers of such plants, among them the United Gas Improvement Company. The Directors carried their investigations as individuals to other cities, and received visits from representatives of several companies. Among the number was Mr. Granger, of the Improvement Company. Mr. Granger was very desirous to put in a water gas plant, and offered to do so for a certain sum; he also tried to buy out the Company, offering therefor the sum of \$450,000, but the proprietors held out for \$550,000. While the Company was considering Mr. Granger's proposition to furnish a water gas plant, the Manchester Company sold out its rights, etc., to the Peoples Gas Light Company. This, according to the testimony of the gentlemen comprising the Board of Directors of the Manchester Gas Light Company, constituted all the negotiations the Company had with Mr. Granger. On the other hand, Mr. Granger claims that the Company had gone so far as to contract with the Improvement Company for introducing his plant, that plans were drawn, and that this Company had begun the manufacture of machinery for the work when intelligence was received that the sale with the Peoples Company had been perfected. The damages set forth in the suit are general, except that of an alleged loss of a patent during the transaction, for which the sum of \$10,000 is claimed. As might have been expected, Mr. Granger made an excellent witness. He is fluent and plausible. His counsel are Bingham & Mitchell, and his leading witness is Lyman P. Gerould, ex-Superintendent of the Manchester Company, whose position in the case is rather peculiar. Naturally, he could not be expected to bear any great volume of love for the people who dismissed him—and his best efforts had always been put forward in managing for many years the fortunes of the old Manchester Gas Light

Company—hence it was only reasonable that he was to be found on the Granger side of the argument. In any case, Mr. Granger testified that he was present when the Directors of the Manchester Gas Light Company closed the contract for the water gas plant, that he overheard all of the conversation, was present when all of the consultations were held, and is positive that the Company made the contract claimed. Against the testimony of Mr. Granger and Mr. Gerould is the testimony of Judge Daniel Clarke, Ex-Governor Moody Currier, Hon. Nathan Parker, Hon. G. Byron Chandler, Chas. F. Warren, Hon. L. B. Clough and others, who swear that no contract was made, that the Directors were simply conferring with the Improvement Company with a view of possibly making a contract if satisfactory terms could be agreed upon, and had the offer in consideration when the Peoples Company came forward and purchased the plant. At the first trial, when the jury disagreed, Mr. Gerould was present and testified; at this trial he was represented by deposition. Hon. J. S. H. Frink, of Greenland, and Judge William L. Foster, of Concord, represented the defendant. The jury, after being out for several hours, reported an inability to agree on a verdict, and they were discharged. The understanding is that 8 were for plaintiff and 4 for defendant.—M. A.”

PRESIDENT McILHENNY, of the Washington (D. C.) Gas Light Company, has placed an order with the Laclede Fire Brick Manufacturing Company for a practical working set of the Coze Inclined Benches. We have no idea of the number of retorts provided for in the installation.

IN regard to this style of bench we may note that the bench of Coze 5's ordered by Mr. Jno. Gimper, for the Springfield (Mo.) plant is almost completed.

THE following, from the Cincinnati *Commercial Gazette*, of the 16th inst., will prove of interest: “I met General Hickenlooper yesterday and asked him what, if any, complications can arise from the operation of the new franchise of the Edison Company, in the face of the one for the nine city squares that is held by the Gas Company. He promptly answered in the negative, and added: ‘The Edison Company can operate anywhere in the city under the franchise it holds by virtue of the decision of the Probate Court—that is if the decision is confirmed by the Supreme Court, to which the case must still go, I think, except in the nine squares of the territory which we hold. That they cannot touch. But this is not a question of territorial rights; it is a question of rates, and the success of the new organization will depend simply on its ability to furnish light cheaper and better than anyone else.’ A statement has gained currency that the General did not want the Edison franchise, for the limited territory mentioned, included in the purchase he made for the Gas Company from Mr. Coffin when the latter was here in connection with the deal. Asked as to the truth of this, the General said: ‘That is true. I did not want it for the simple reason that it is not worth anything to us. And, indeed, there is nothing in the electric lighting business at all, and will not be for some time to come. But the territory included in that limited franchise is the most promising of any in the city, and we will see to it that the new company does not trespass upon it. To return to the matter of money in the business. These men from the outside have made a mistake concerning Cincinnati, having based their calculations upon their experience in other cities where gas is from \$1.50 to \$2.50 per 1,000. When they come here where it is furnished at \$1.15 per 1,000 they are at a loss. I will tell you what I want to see in this town and that is the time when a man can come to the gas office to order whatever he wants in the way of light. If he wants the electric send him to one desk, if gas then to another, and if he wants both gas and electric send him to both desks. We want to do business on a basis of 10 per cent. profit. It can't be carried on for less than that, as we are not in it for the glory of the thing. Just as soon as the electric interest reaches a point where the profits exceed the limit I have named the the prices will be lowered to meet it, and not till then. I do not believe in the plan of giving any one company the exclusive control of the conduit system. There are several other companies here with equal rights in the matter, and there is no reason why each one of them should not go to work and tear up the pavements, thus occupying the streets from curb to curb with trenches, none of them less than four feet in width. One conduit should be made to serve the needs of all companies, and it should be given to a conduit company to construct and maintain. Those utilizing it should pay a rate equivalent to 10 per cent. profit to the operating corporation for its use.”

THE proprietors of the Standard Gas Company submitted a bid to the Gas Commission for street lighting in the districts traversed by its mains. Its offer is to light a total of 2,505 lamps, at the rate of \$13.043 for each

lamp. The rate at which the Company's charter requires it to supply the city is \$12.50 for each light, burning during 3,833 hours annually. Under the city's specifications the lights are to burn during 4,000 hours, and the Company accordingly demands a proportionate increase.

AT the annual meeting of the Carlisle (Pa.) Gas and Water Company the following officers were elected: Directors, Dr. W. W. Hale and Messrs. John Hays, R. M. Henderson, J. H. Bosler, C. H. Woodward and L. L. Line.

THE proprietors of the Altoona (Pa.) Gas Company have decided to increase their storage capacity by adding an outer section to their 90-foot holder. The work will be carried out by the Kerr Murray Manufacturing Company, of Fort Wayne, Ind.

MR. M. A. BROWN is acting as Superintendent of the Perth Amboy (N. J.) Gas Light Company, and it is possible that he will receive the permanent appointment. In the meantime we might remark that Mr. Patrick Convery, the newly-elected President of the Company, does not intend to pose as a figurehead in connection with the management of the Company's business. He is the right man in the right place.

THE authorities of Napa City (Cal.) have instituted suit against the Napa Electric Light Company for the forfeiture of its franchise.

MR. C. M. WILLIAMS, the enterprising Superintendent of the Helena (Mont.) Gas Light Company, has about completed his plans for bettering the condition of that works, and the cost of the scheme will not be less than \$50,000. Briefly told, he will erect a new purifying house (40 feet by 100 feet), and install therein handsome and modern condensing, scrubbing and purifying apparatus. A station meter will also form part of the outfit. The main system will be improved by the placing of 5,200 feet of 12-inch pipe, and two miles of smaller sizes will be put down. The 12-inch pipe is to take the place of the present 4 and 3-inch mains in Broadway. When all is finished Supt. Williams will be so situated that he can manufacture and distribute 300,000 cubic feet of gas each 24 hours.

THE strike among the gas stokers at Hamburg, Germany, has assumed a serious phase. Conflicts have occurred between the stokers and the police, and several of the offenders have been jailed.

TREASURER FRANK S. RICHARDSON, of the North Adams Gas Company, having “bettered” the gas and electric light service of his city, has concluded to “better” his own condition. At least we infer so from an invitation now before us to witness a marriage ceremony that will bind him to Miss Alice Rudderow Bonnell, of Jersey City Heights. The ceremony will take place on the afternoon of June 4th. May fortune ever smile upon them.

THE following are the net rates charged for gas by the proprietors of the Milton (Pa.) Gas Light Company, the gross being fixed at \$2.50 per 1,000.

Monthly Consumption.	Discount per M.	Net per M.
200 feet or under.....		\$2.50
Over 200 feet, but under 500 ft.	50 cents	2.00
1,000 feet.....	60 “	1.90
3,000 feet.....	65 “	1.85
7,000 feet.....	70 “	1.80
12,000 feet.....	80 “	1.70
20,000 feet.....	90 “	1.60
25,000 feet.....	\$1.00 “	1.50

The time for prompt payment is fixed at 15 days. These are very liberal figures for a place like Milton, whose population is not in excess of 6,000. As in most every other instance where good management is displayed the number of meters set is far in excess of that usually returned from other places where the gas policy is not liberal. The Milton Company has 260 meters in use, and a fairly good return per month is made from each one. Secretary Folmer, to whom the credit of building up the Company's business is most largely due, will make a strenuous effort this season to popularize the use of gas for cooking.

WE understand that at the annual meeting of the Citizens Gas Light and Heating Company, of Bloomington, Ills., it was decided to build a new works at a cost of something like \$25,000. The old Gridley plant will be abandoned. The only change in the executive management was the election of Mr. H. Gapen to the vacancy in the Board of Directors occasioned by the death of Geo. A. Tryner.

SECRETARY WM. L. WELSH, of the Oswego (N. Y.) Gas Light Company, evidently believes in keeping close to the leaders, and we think so from the following notice that is now appearing in the columns of the *Oswego Daily Palladium*: "The Oswego Gas Light Company desires to give notice that on and after June 1st next the price of gas will be reduced to \$1.75 per 1,000 cubic feet. If bills are paid within 10 days after presentation the following discounts will be allowed: On all bills under 3,000 feet per quarter, 10 cents per 1,000; on all bills of 3,000 feet or over per quarter, 25 cents per 1,000, making net prices \$1.65 and \$1.50 per 1,000."

MRS. HARRIET A. SCHWAB, of Jersey City, N. J., has brought suit against the United Gas Improvement Company, as lessee of the Jersey City Gas Light Company, for \$20,000 damages occasioned plaintiff by a gas explosion in 1888. She alleges negligence on the part of the Company to repair certain leaks to a service pipe, defendant having received timely notice of the bad condition of the pipe. The defense interposed is contributory negligence, in that the service, which had been originally paid for by the one who ordered it, was private property, hence should be kept in order by its owner.

SINCE the above was written we have received the following further particulars respecting the suit and its outcome: "Counsel in the case took nearly four hours to sum up, the arguments being made by Counselor John A. McGrath for the plaintiff, and Ex-Governor Bedle for the Company. In charging the jury Judge Dixon touched lightly upon the facts of the case, confining his attention to points of law. He held that the evidence pointed to the fact that the leak in the gas pipe, the prime cause of the explosion, had occurred in the joint between the horizontal and vertical lengths, near the basement floor. Carelessness on the part of the Company was indicated by a failure to repair this leak when notified. The plaintiff's duty was to have notified the Company, not once, but as often as a reasonably prudent person for his own protection would do. It was a part of the Company's duty to inspect the pipes and keep them in repair to avoid danger. 'The evidence,' the court charged, 'showed that the plaintiff did notify the Company, and also that no repairs were made. If you believe this testimony, the plaintiff is entitled to receive such compensation as you deem sufficient for the sufferings she has undergone, for her disfigurement, and inability to earn a living.' Mrs. Schwab was a music teacher before the calamity, and her hands were badly mutilated. Continuing, Judge Dixon said: 'The jury must also determine, before awarding damages to the plaintiff, whether or not it was careless on her part to light a match in a place where the smell of the escaping gas was so strong, and whether a reasonably prudent person would have done so. If the plaintiff was careless in so doing it would be contributory negligence on her part, and she would not be entitled to any damages because of injuries so arising.' The jury, after an absence of two hours, brought in a verdict of \$6,000 for the plaintiff. The case will be appealed.—J. C. J."

THE Committee on Manufactures, Massachusetts Legislature, has reported for passage the bill to permit the consolidation in that State of gas and electric light companies. An amendment is recommended to the measure in its original shape so that the agreement for consolidation shall be executed by the presidents of the constituent companies only after it has been approved by a vote of two-thirds in number and interest of the stockholders of each corporation at a special meeting called for the purpose.

MR. ST. JOHN, as Agent for the company controlling the Pintsch system for lighting railway cars in this country, has closed a contract with Messrs. Alston & Boylston, of Atlanta, Ga., for the erection of a works in that city in which to manufacture a supply of gas for the illumination of the passenger coaches of the Georgia Central Railroad.

THE plant of the Gainesville (Fla.) Gas and Electric Light Company has been leased to the Southern Gas Trust and Construction Company, of New Jersey.

THE generating plant of the Columbia (Tenn.) Electric Light Company was "knocked out" by a lightning stroke. The Thomson-Houston Company which installed the apparatus had failed to provide "lightning arresters" in connection with it.

MESSRS. BISHOP & BARRET, of the Louisville Gas Company, have about completed a prolonged tour of inspection of Eastern and mid-West electric lighting plants. This looks as if the Louisville Company intends to speedily avail itself of the charter amendment permitting it to engage in the distribution of electrical currents.

THE Consumers Gas Company, of Reading, Pa., has been awarded a 5-years' contract for furnishing gas to the stations and passenger coaches of the P. and R. Railroad Company. The Gas Company will rebuild the gas works of the P. and R. Company, that were recently destroyed by fire. It will be remembered it was asserted, when these works were so destroyed, that the P. and R. Company would substitute electricity for gas.

MANAGER AFRICA, of the Peoples Gas Company, of Manchester, N. H., has vanquished the strikers.

MESSRS. HAMILTON DISSTON and Joseph B. Hancock have been re-elected Trustees of the Northern Liberties gas works, of Philadelphia.

WE understand that the franchises, plant, etc., of the Le Mars (Ia.) Water and Light Company have been purchased by Mr. J. H. Winchell, who paid \$45,000 for the same:

THE Galena (Ills.) gas works have also changed hands. The transfer price is not known to us.

THE proprietors of the Hamilton (O.) Gas Light and Coke Company assert that they will undersell the city, no matter what figure the latter may determine to charge ordinary consumers for gas supplied from the municipal works.

AN Associated Press despatch, dated Erie, Pa., May 15, says: "A few months ago the people of Erie undertook to boycott the Pennsylvania (natural) Gas Company, on account of a raise in the rates. The boycott failed, and the City Council asked the courts for an injunction to compel the Pennsylvania Company to take up its pipes and abandon its plant. The order was asked for on the ground that the Company had refused to furnish the manufacturing establishments gas as they had promised when Council gave the Company the use of the streets. The Company demurred, and the court sustained this by dismissing the bill, on the ground that Councils could vote the Company the use of the streets or not, but could name no conditions."

Two hundred and twenty-five shares of stock in the New Bedford (Mass.) Gas Light Company were sold at auction on Saturday last.

AT the annual meeting of the Glens Falls (N. Y.) Gas Light Company the following officers were elected: President, D. H. Cowles; Vice-President, F. A. Sabbaton; Secretary and Treasurer, F. F. Pruyn; Superintendent, H. A. Brooks.

THE Directors of the Street and Sewer Department, of Wilmington, Del., have refused permission to J. Edward Addicks to tear up the streets for the purpose of burying gas mains. The action of the authorities is based upon what they term the confusion of corporate titles under which Mr. Addicks seeks to operate, and the absence of what they consider any responsible organization to whom to grant the privilege of laying pipes.

THE Dowagiac Gas and Electric Company has been incorporated to operate in Dowagiac, Cass county, Michigan. Capital, \$15,000.

THE National Electric Manufacturing Company of Eau Claire, Wis., is under contract to install a plant of 100 arcs and 1,000 alternating incandescents at Asheville, N. C., and a 750-light alternating incandescent plant at Anderson, S. C. The 600-light direct current plant that is being installed by the Company at the Hotel Normandie, Washington, D. C., will be put in duty next week.

THE quarterly bills that will be handed to the consumers of the Poughkeepsie (N. Y.) Gas Light Company on June 2d will be made out on the following basis: \$2, \$1.75, \$1.50, \$1.35, \$1.25, or \$1.00 per 1,000 cubic feet. The quarterly consumption, of course, determines the charge, save in respect to the minimum figure named, which applies to gas used for cooking, heating or power. If bills are not paid in ten days from delivery, ten per cent. will be added.

ANYONE interested in the sick-benefit, funeral-aid and death-beneficiary associations of the United States can help make the statistics of their organization for the forthcoming census more complete and disseminate the knowledge of the good work they are doing by sending the names of such societies as they may know of and the addresses of their principal officers to Mr. Chas. A. Jenney, Special Agent of the Eleventh Census, 58 William street, New York city.



A. M. CALLENDER & CO.,

PROPRIETORS.

EDITOR—Jos. R. Thomas, C.E.

ASST. EDITOR—T. J. Cunningham.

MANAGER—C. E. Sanderson.

PUBLISHED ON EACH MONDAY OF THE YEAR AT
No. 42 Pine Street, New York.

This is a recognized official organ of
LIGHT, HEAT, STEAM, WATER SUPPLY,
VENTILATION, SANITARY IMPROVEMENT,
AND GENERAL SCIENCE

TERMS:

SUBSCRIPTION—Three Dollars per annum, in advance. Single copies, 10 cents.

AGENTS.

NEW YORK.—AMERICAN NEWS CO., 39 and 41 Chambers Street.
PHILADELPHIA.—PRATT & CO., Corner Ninth and Arch Streets.
Germany.—B. WESTERMANN & CO., of New York.

MONDAY, MAY 26, 1890.

Gas Stocks.

Quotations by Geo. W. Close, Broker and Dealer in Gas Stocks,
16 WALL ST., NEW YORK CITY.

MAY 26.

All communications will receive particular attention.
The following quotations are based on the par value of \$100 per share.

	Capital.	Par.	Bid	Asked
Consolidated.....	\$35,430,000	100	104	104½
Central.....	500,000	50	85	95
“ Scrip.....	220,000	—	95	100
Equitable.....	4,000,000	100	118	122
“ Bonds.....	1,000,000	—	113	115
Harlem, Bonds.....	170,000	—	—	—
Metropolitan, Bonds....	658,000	—	115	120
Mutual.....	3,500,000	100	110	—
“ Bonds.....	1,500,000	—	100	102
Municipal, Bonds.....	750,000	—	—	—
Northern.....	—	50	—	—
“ Bonds.....	150,000	—	—	100
Standard Gas Co —				
Common Stock.....	5,000,000	100	—	45
Preferred.....	5,000,000	100	84	87
Yonkers.....	—	50	112	—
Richmond Co., S. I.	346,000	50	—	—
“ Bonds.....	20,000	—	—	—
Gas Co's of Brooklyn.				
Brooklyn.....	2,000,000	25	114	117
Citizens.....	1,200,000	20	69	—
“ S. F. Bonds....	320,000	1000	100	103
Fulton Municipal.....	3,000,000	100	127	130
“ Bonds....	300,000	—	100	105
Peoples.....	1,000,000	10	86	88
“ Bonds (7's).....	368,000	—	100	—
“ “ (6's).....	94,000	—	100	—
Metropolitan.....	1,000,000	100	102	—
Nassau.....	1,000,000	25	120	—
“ C'tfs.....	700,000	1000	100	102
Williamsburgh.....	1,000,000	50	125	—
“ Bonds....	1,000,000	—	108	112

Out of Town Gas Companies.

Boston United Gas Co. —				
1st Series S.F. Trust	7,000,000	1000	93	93½
2d “ “ “	3,000,000	1000	71	72
Bay State Gas Co. —				
Stock.....	5,000,000	50	84	—
Income Bonds.....	2,000,000	1000	94½	95½
Buffalo Mutual, N. Y....	750,000	100	90	95
“ Bonds....	200,000	1000	95	100
Citizens, Newark.....	1,000,000	50	155	160
“ “ Bonds.	45,000	—	—	—
Chicago Gas Trust.....	25,000,000	100	62½	—
Chicago Gas Light. & Coke Co. —				
G't'd Gold Bonds	7,650,000	1000	97½	98¼
Equitable Gas & Fuel Co., Chicago, Bonds	2,000,000	1000	94½	95½
People's Gas and Coke Co., Chicago —				
1st Mortgage.....	2,100,000	1000	—	100
2d “	2,500,000	1000	96	100
Consumers Gas Light Co., Jersey City.....				
Bonds.....	600,000	1000	80	—
Cincinnati G. & C. Co..	6,000,000	100	201	203
Consumers Toronto....	1,000,000	50	190	200
Central, S. F., Cal.....	—	—	80	90
Capital, Sacramento, Cal	—	—	58	—
Consolidated, Balt.....	11,000,000	100	52	52½
“ Bonds.....	6,400,000	—	107	107½
Citizens Gas Lt. Co., Rochester, N. Y.....				
Bonds.....	500,000	—	75	90
“	250,000	—	—	—
Hartford, Conn.....	750,000	25	102	108
Jersey City.....	750,000	20	170	175
Laclede Gas Light Co., St. Louis, Mo. —				
Common Stock....	7,500,000	100	25	25½
Preferred “	2,500,000	100	68	70
Bonds.....	9,034,400	1000	87	87½

Advertisers Index.

	Page
GAS ENGINEERS.	
Jos. R. Thomas, New York City.....	753
Wm. Henry White, New York City.....	759
Wm. Mooney, New York City.....	753
William Gardner, Pittsburgh, Pa.....	753
Fred. Bredel, N. Y. City.....	755
GAS WORKS APPARATUS AND CONSTRUCTION.	
James R. Floyd & Sons, New York City.....	759
Continental Iron Works, Greenpoint, L. I.....	759
Delly & Fowler, Phila., Pa.....	759
Kerr Murray Mfg. Co., Fort Wayne, Ind.....	756
Stacey Mfg. Co., Cincinnati, Ohio.....	759
Bartlett, Hayward & Co., Baltimore, Md.....	757
Morris, Tasker & Co., Limited, Phila., Pa.....	757
Davis & Farnum Mfg. Co., Waltham, Mass.....	756
R. D. Wood & Co., Phila., Pa.....	758
Bouton Foundry Co., Chicago, Ills.....	759
Smith & Sayre Manufacturing Co., New York City.....	758
Fred. Bredel, N. Y. City.....	755
United Gas Improvement Co., Phila., Pa.....	749
National Gas Light and Fuel Co., Chicago, Ills.....	746
Simpkin & Hillyer, Richmond, Va.....	743
GAS AND WATER PIPES.	
Gloucester Iron Works, Phila., Pa.....	753
Mellert Foundry and Machine Co., Reading, Pa. (John Fox, Selling Agent, N. Y.).....	753
Ohio Pipe Co., Columbus, Ohio.....	753
M. J. Drummond, New York City.....	753
R. D. Wood & Co., Phila., Pa.....	758
Warren Foundry & Machine Co., New York City.....	753
Donaldson Iron Co., Emaus, Pa.....	753
Dennis Long & Company, Louisville, Ky.....	753
PROCESSES.	
National Gas Light and Fuel Co., Chicago, Ills.....	746
Bartlett, Hayward & Co., Baltimore, Md.....	757
Wm. Henry White, N. Y. City.....	759
United Gas Improvement Co., Phila., Pa.....	749
INCLINED RETORTS.	
Laclede Fire Brick Manuf'g Co., St. Louis, Mo.....	744

GASHOLDER TANKS.

W. C. Whyte, New York City.....	746
J. P. Whittier, Brooklyn, N. Y.....	751

GASHOLDER PAINT.

The Government Waterproof Paint Co., Boston, Mass.....	744
--	-----

RETORTS AND FIREBRICK.

J. H. Gautier & Co., Jersey City, N. J.....	754
B. Kreisler & Sons, New York City.....	754
Adam Weber, New York City.....	754
Laclede Fire Brick Manuf'g Co., St. Louis, Mo.....	754
Brooklyn Retort and Fire Brick Works, Brooklyn, N. Y.....	754
Borgner & O'Brien, Phila., Pa.....	754
James Gardner, Jr., Pittsburgh, Pa.....	754
Henry Maurer & Son, New York City.....	755
Chicago Retort and Fire Brick Co., Chicago, Ills.....	754
Baltimore Retort and Fire Brick Co., Baltimore.....	754
Oakhill Gas Retort and Fire Brick Co., St. Louis, Mo.....	754
Boston Fire Brick Works, Boston, Mass.....	754

SCRUBBERS AND CONDENSERS.

G. Shepard Page, New York City.....	712
R. D. Wood & Co., Phila., Pa.....	758

REGENERATIVE FURNACES.

Bartlett, Hayward & Co., Baltimore, Md.....	757
Fred. Bredel, New York City.....	755
Chicago Retort and Firebrick Co., Chicago, Ills.....	754
J. H. Gautier & Co., Jersey City, N. J.....	755

GAS GOVERNORS.

Connelly & Co., New York City.....	751
Fred. Bredel, N. Y. City.....	755
Friedrich Lux, London, England.....	743

SELF-SEALING MOUTHPIECE DOORS.

Smith & Sayre Mfg. Co., New York City.....	758
--	-----

TAR AND CARBONIC ACID EXTRACTOR.

Geo. Shepard Page, N. Y. City.....	748
------------------------------------	-----

CEMENTS.

C. L. Gerould & Co., Brooklyn, N. Y.....	754
--	-----

GAS ENRICHERS.

Standard Oil Co., Cleveland, Ohio.....	760
--	-----

GAS METERS.

John J. Griffin & Co., Phila., Pa.....	762
American Meter Co., New York and Philadelphia.....	763
The Goodwin Gas Stove and Meter Co., Philadelphia, Pa.....	763
Helme & McIlhenny, Phila., Pa.....	763
D. McDonald & Co. Albany, N. Y.....	763
Nathaniel Tufts, Boston, Mass.....	763
Maryland Meter and Manufacturing Co., Baltimore, Md.....	744
Bell & Jones, Philadelphia, Pa.....	762
Harris Bros. & Co., Philadelphia, Pa.....	762

EXHAUSTERS.

The P. H. & F. M. Roots Co., Connersville, Ind.....	750
Smith & Sayre Manufacturing Co., New York City.....	758
Wilbraham Bros., Philadelphia, Pa.....	751
Connelly & Co., New York City.....	751

GAS COALS.

Penn Gas Coal Co., Phila., Pa.....	761
Perkins & Co., New York City.....	760
Newburgh Orrel Coal Co., Baltimore Md.....	761
Despard Coal Co., Baltimore, Md.....	761
Chesapeake and Ohio R. R. Coal Agency, N. Y. City.....	761
Westmoreland Coal Company, Phila., Pa.....	761
J. & W. Wood, New York City.....	760

CANNEL COALS.

Perkins & Co., New York City.....	760
J. & W. Wood, New York City.....	760

VALVES.

Ludlow Valve Manufacturing Co., Troy, N. Y.....	752
John McLean, New York City.....	752
Chapman Valve Manufacturing Co., Boston, Mass.....	752
R. D. Wood & Co., Phila., Pa.....	758
The P. H. & F. M. Roots Co., Connersville, Ind.....	750

GAS ENGINES.

Schleicher, Schumm & Co., Phila., Pa.....	728
Clerk Gas Engine Co., Phila., Pa.....	752
Van Duzen Gas Engine Co., Cincinnati, Ohio.....	752

ENGINES AND BOILERS.

Jarvis Engineering Co., Boston, Mass.....	751
Ball Engine Co., Erie, Pa.....	744

STEAM PUMPS.

Van Duzen & Tift, Cincinnati, Ohio..... 743

GAS LAMPS.

Welsbach Incandescent Gas Light Co., Phila., Pa..... 745
 The Siemens-Lungren Company, Philadelphia, Pa..... 745
 Fiske, Coleman & Company, Boston, Mass..... 754

PURIFIER SCREENS.

John Cahot, New York City..... 752
 Bartlett, Hayward & Co., Baltimore, Md..... 752

GAS STOVES.

American Meter Co., New York and Philadelphia..... 747
 The Goodwin Gas Stove and Meter Co., Phila. Pa..... 764
 George M. Clark & Company, Chicago, Ills..... 745
 D. McDonald & Co., Albany, N. Y..... 763
 Maryland Meter and Manufacturing Co., Baltimore, Md.... 744
 Bell & Jones, Philadelphia, Pa..... 762
 Chicago Gas Stove Company, Chicago, Ills..... 746

STREET LAMPS.

J. G. Miner, Morrisania, New York City..... 707
 Bartlett Street Lamp Man'g Co., New York City..... 743

BURNERS.

C. A. Gefroerer, Phila., Pa..... 760
 H. W. Rappleye, Philadelphia, Pa..... 368
 Moses G. Wilder, Phila., Pa..... 743

STEAM BLOWER FOR BURNING BREESE.

H. E. Parson, New York City..... 742

PURIFYING MATERIAL.

Connelly & Co., New York City..... 751
 Friedrich Lux, London, England..... 743
 Edgewater Lime Works, Edgewater, N. J..... 743

COKE CRUSHER.

C. M. Keller, Columbus, Ind..... 761

ELECTRICAL APPARATUS.

Wm. Henry White, N. Y. City..... 759

BOOKS, ETC.

Gerould's System Gas Bookkeeping..... 743
 1 90, Directory, 1890 751
 King's Treatise..... 753
 Scientific Books..... 755
 Management of Small Gas Works 752
 Practical Electric Lighting..... 751
 Electric Light Primer..... 751
 American Gas Engineer and Superintendents' Handbook... 761
 Digest of Gas Law..... 743
 Fuel and its Applications 743
 Newbigging's Handbook..... 755

WANTED,

By an experienced man,

Situation as Inspector.

Thoroughly competent in all branches of distribution work.
 780-2 Address INSPECTOR, care this Office.

Position Wanted

As Superintendent or Assistant of a Gas Works,
 By a man who can give the best of references. Thoroughly
 understands the manufacture and distribution of gas and the
 construction of works. Address
 779-5 "M.," care this Journal.

POSITION WANTED

As Superintendent of Gas Works.

Eleven years' experience in the manufacture of coal gas. Best
 of references given.
 W. L. CARVER, Supt.,
 778-8 Carthage, Mo.

FOR SALE,

The Ironwork for Twelve Benches of 6's, vis.:
Cast Iron Hydraulic Main.
7-inch Dip-Pipes, Stand-Pipes, and Bridge-
Pipes, complete.
Floyd Mouthpieces and Self-Sealing Lids, 15x26 In.
 Lids and Mouthpieces only in use over a year. Will be sold
 cheap.
 ISAAC C. BAXTER,
 772-1f Detroit (Mich.) Gas Lt. Co.

To Gas Burner Makers.

WANTED—Samples of all ordinary modern Gas Burners—Union
 Jets, Batwings, Regulating Burners for Oil, Wood, Water, and
 Coal Gas. No Argands. Say four of each, from the smallest to
 the largest. Also samples of old, early, and out-of-date Burn-
 ers, for comparison when lighted. The undersigned is about to
 open a large Exhibition of Gas Burners in Dunedin, N. Z., and
 the makers' names will be attached prominently to respective
 Burners. Samples and lists to be forwarded to the undersigned
 per parcel post.

WILLIAM DALEY, Engineer and Attorney,
 The City of Dunedin Suburban Gas Co.,
 Caversham, New Zealand.

**Who Makes
 TAR SEPARATORS?**

Prices and particulars, address
 "X. Y." care this Journal.

**GEROULD'S
 System Gas Bookkeeping.**

Approved and adopted by many of the prom-
 inent Gas Engineers of the Country.

Sample Sheets and Price-List furnished free on application to

L. P. GEROULD, - - Mendota, Ill.

FRIEDRICH LUX,

Ludwigshafen am Rhein and London.

**Lux Mass,
 GAS GOVERNORS,
 Gas Balance.**

Simpkin & Hillyer

RICHMOND, VA.

MANUFACTURERS OF

Gas Works Apparatus

**BENCH CASTINGS, CONDENSERS,
 Scrubbers, Purifiers, Dry Center Seals,
 FOUR-WAY VALVES, GAS VALVES,
 SULPHATE OF AMMONIA APPARATUS,
 TANKS, ENGINES, BOILERS,
 PUMPS, ETC., ETC.**

Plans, Specifications and Estimates furnished for new works,
 or alteration of old works. Correspondence solicited. Works,
 Newport News, Va.

EDGEWATER LIME WORKS

Chas. F. McKenna, Proprietor.

SHELL LIME.

Lime by the Cargo for Gas Purification.

EDGEWATER, BERGEN CO., N. J.

Write for Testimonials and Prices.

MOSES G. WILDER, MECH. ENGR.

816-18-20-22 Cherry St., Phila., Pa.

Volumetric Lamp Governors

FOR GAS LAMPS & HIGH-POWER BURNERS.

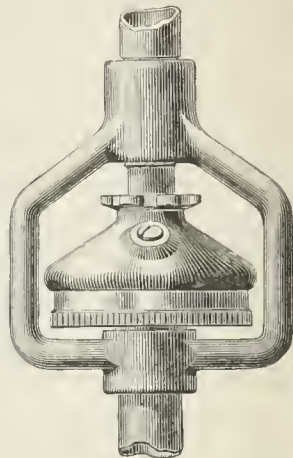

GOVERNOR BURNERS

for

STREET LAMPS AND
 GENERAL USE,

and

GOVERNORS FOR ARGAND
 AND OTHER COMMON GAS
 BURNERS IN ALL SIZES.

HORIZONTAL

Governors

Specially adapted for
 GAS STOVES, FURNACES,
 Etc., Etc.

It is well known that a large majority of all High Power Gas
 Lamps in the United States have my Governors attached, and
 they are always used by the leading makers of these lamps. To
 remove any excuse for the use by anyone of inferior and in-
 fringing Governors, a reduction in price has been made, and all
 exclusive contracts are cancelled.

Correspondence Solicited with all who require a Reliable
 Governor.

Bartlett Street Lamp Mfg. Co.

MANUFACTURERS OF

Globe Lamps,

FOR

Streets, Parks, Public
 Buildings, Railroad
 Stations, etc.

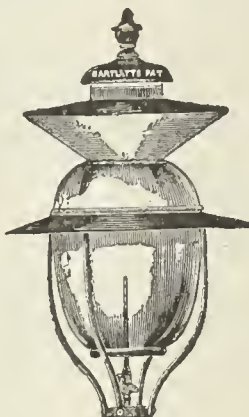

LAMP POSTS

A Specialty.

Office and Salesroom,

40 & 42 COLLEGE PLACE, - - N. Y. CITY.

Gas Companies and others intending to erect Lamps
 and Posts will do well to communicate with us.



GREENOUGH'S

"DIGEST OF GAS LAW."

Price, \$5.00.

This is a valuable and important work, a copy
 of which should be in the possession of every gas
 company in the country, whether large or small.
 As a book of reference it will be found invaluable.
 It is the only work of the kind which has ever
 been published in this country, and is most com-
 plete. Handsomely bound. Orders may be sent to

A. M. CALLENDER & CO.,

42 Pine Street, N. Y.

CHARLES E. DICKEY.

JAMES B. SMALLWOOD.

CHARLES H. DICKEY.

THE MARYLAND METER AND MANUFACTURING CO.

Established 1866.

BALTIMORE, North & Saratoga Sts.

CHICAGO, 197 Michigan Street.

NEW YORK, 766 Broadway.

BOSTON, 4 Central Street.

ST. LOUIS, 1115 Olive Street.

SAN FRANCISCO, 330 Pine Street.

CONSUMERS' & STATION METERS, PRESSURE GAUGES, Etc., Etc.
"Success" and "Perfect" Gas Stoves.

LACLEDE FIRE BRICK MANUFACTURING COMPANY,

ST. LOUIS, MO.

Exclusive Agents in the United States

FOR THE

Coze System of Inclined Retorts.

IT IS THE COMING BENCH FOR MAKING COAL GAS.

It will Save from 50 to 60 per ct. in Labor.

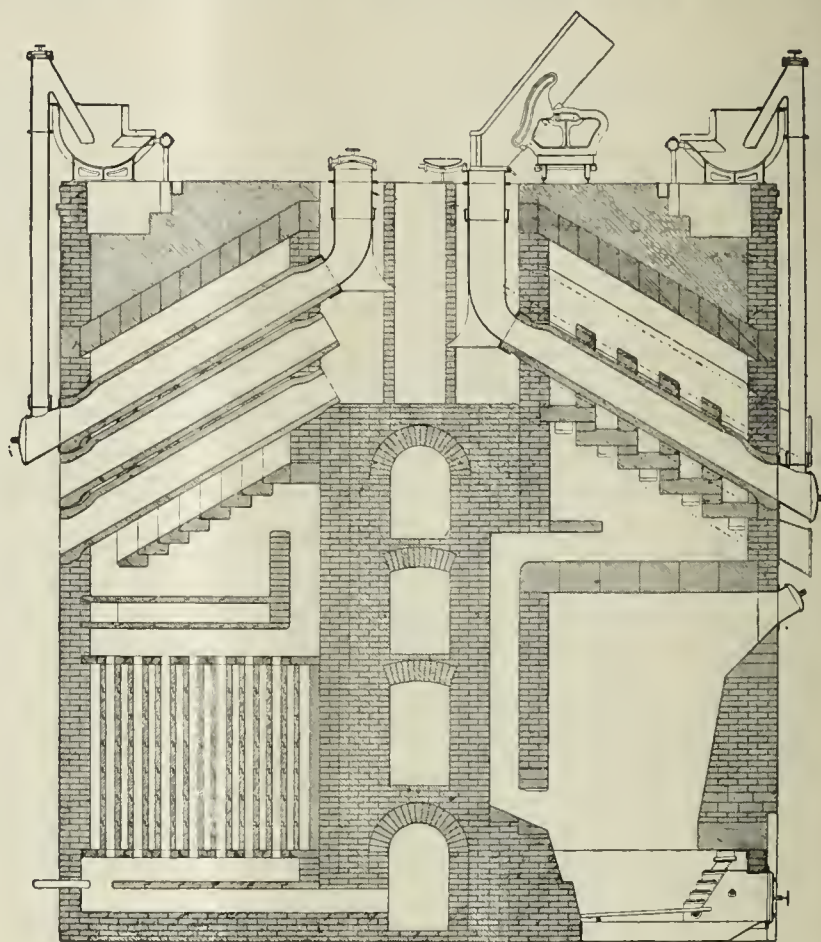
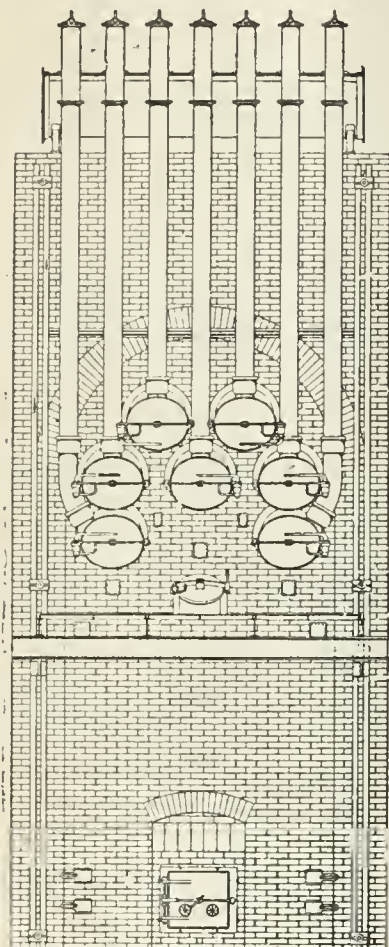

ESTIMATES AND PLANS FURNISHED BY THE

LACLEDE FIRE BRICK MFG. CO., ST. LOUIS, MO.

BALL AUTOMATIC CUT OFF ENGINE
MADE ONLY BY **THE BALL ENGINE CO**
ERIE PA.

GASHOLDER PAINT.

Use Only

THE GOVERNMENT WATERPROOF PAINT.

Proof against Ammonia, and Absolutely Waterproof. Send for Prices and Particulars.

THE GOVERNMENT WATERPROOF PAINT CO., 122 Milk Street, Boston, Mass.

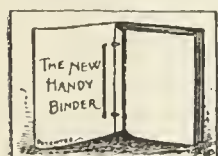

THE NEW HANDY BINDER.

This article may be described as elegant in appearance, strong, durable, and possessing many special qualities of its own. It allows the opening of the pages perfectly flat, whether one or several numbers are in the binder. Any number can be taken out and replaced without disturbing the others. The papers are not mutilated for subsequent binding in permanent form. The binder is supplied with gilt side title, and is an ornament to any desk or reading table. The JOURNAL, filed in the Handy Binder, becomes a volume of great value, always convenient for instant reference. Handy Binder, Postage paid, \$1.00.

A. M. CALLENDER & CO., 42 Pine St., N. Y.



CHICAGO GAS STOVE CO.

MANUFACTURERS OF ALL KINDS OF

Gas Cooking and Heating APPLIANCES.

117-119 Lake St., CHICAGO.

Send for Catalogue.

The Gordon Portico Lamp.

A successful Competitor of the Arc Electric Light for lighting Store Fronts, Show Windows, Depots, Railway Sheds, etc., etc.

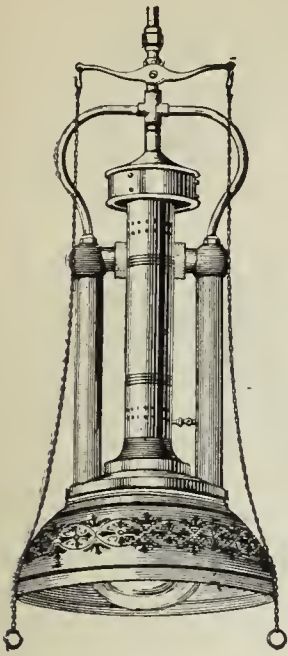

Gordon Portico Lamp.

The Gordon Street Lamp.

A Successful Competitor of the Arc Electric Light for lighting Streets, etc., etc.

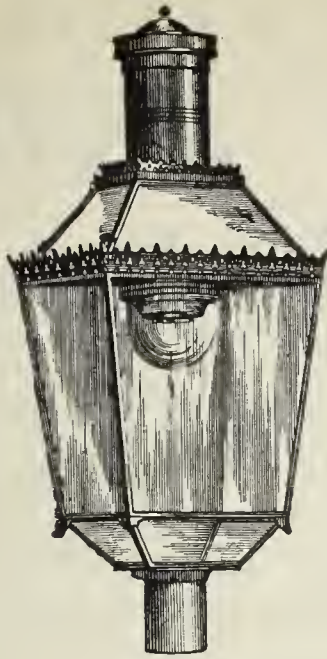

Gordon Street Lamp.

The Lungren Lamp.

A Successful Competitor of the Incandescent Electric Light for Interiors, etc. Is especially applicable for the lighting of Offices, Stores, Factories, Mills, Show Windows, Libraries, and all situations where an increased illumination is desired.

More than 25,000 Lungren Lamps are now in use. Testimonials, references, or any desired information will be cheerfully given.

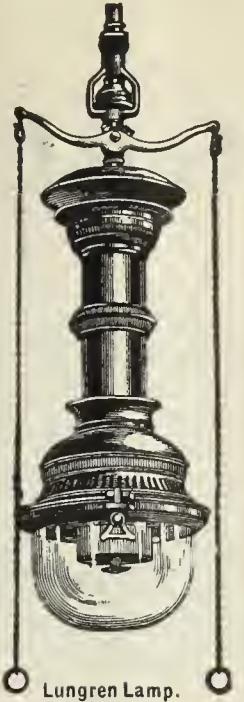

Lungren Lamp.

THE SIEMENS-LUNGREN CO., N.E. Cor. 21st St. & Washington Av., PHILADELPHIA.

WELSBACH SYSTEM OF Incandescent Gas Lighting.

OFFICE, DREXEL BUILDING, PHILA., PA.

At the Fall Session of the Board of Supervisors of Winnebago County, held at the County Court House, Oshkosh, Wis., Nov. 26, 1889, the report submitted by Mr. C. W. Cook, Chairman of the Committee on Public Buildings, recommending the use of the Welsbach Incandescent Gas Burner in the Buildings under their charge, was unanimously adopted, because of the extreme economy in the consumption of Gas and the superior character of the light obtained.

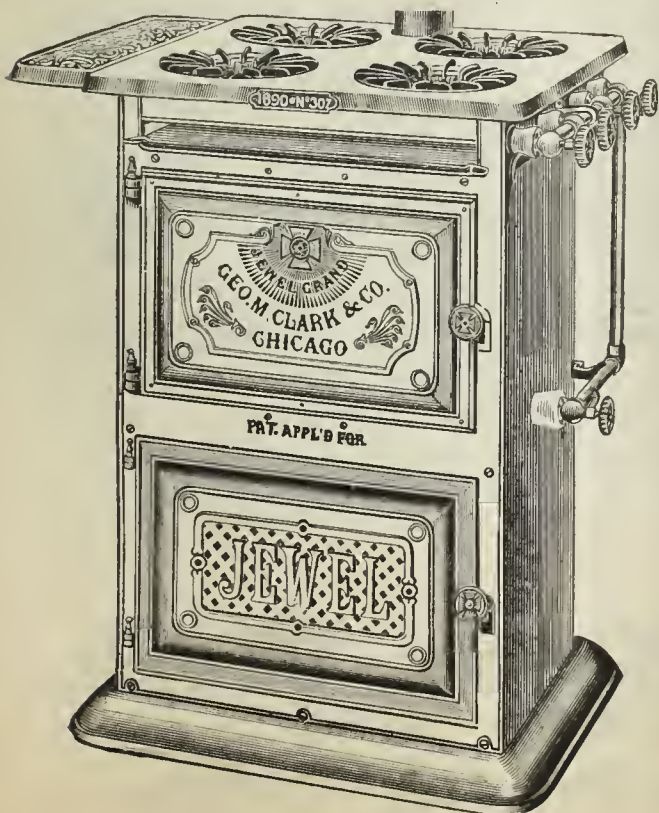

JEWEL GAS STOVES

MANUFACTURED BY

GEORGE M. CLARK & COMPANY,

Nos. 157 & 159 Superior Street, - - - Chicago, Ill.

EVERY CONCEIVABLE SIZE AND STYLE,

Ranging in Prices from \$1.50 to \$30.00.

WE USE NO GAS COCKS.

All Flames are Regulated by a Direct Needle Valve.

The JEWEL

IS THE

Only Well-Made Gas Stove on the Market.

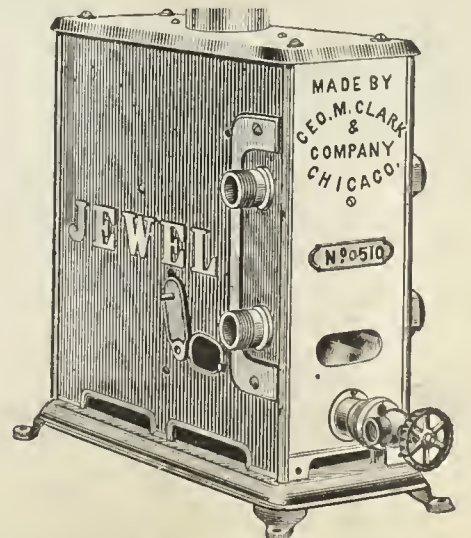

Jewel Circulating Water Heater.

Write for our 1890 Catalogue and see for yourself.

NATIONAL GAS LIGHT AND FUEL CO.,

218 La Salle Street, Chicago.

C. D. HAUK, Prest. & Gen'l Manager. A. W. GREEN, Vice-Prest. N. A. McCLARY, Sec. & Treas. E. E. MORRELL, Engr.

GAS WORKS

Built, Remodeled, Leased, and Purchased.

71 Springer Cupolas have been installed in the U. S. during the past four years.

The total capacity of Springer Apparatus now in use is over 25,000,000 ft. daily.

THE SPRINGER CUPOLA SYSTEM

Has Proven Itself the most Economical and Satisfactory Method of Gas Manufacture ever brought to the attention of the Gas Fraternity.

GUARANTEED ESTIMATES of Cost of Gas Furnished on Application.

GASHOLDER TANK CONSTRUCTION, ETC.

Gas Companies and others about to erect Gasholders will find it profitable to consult W. C. Whyte, who for over 30 years has made a specialty of

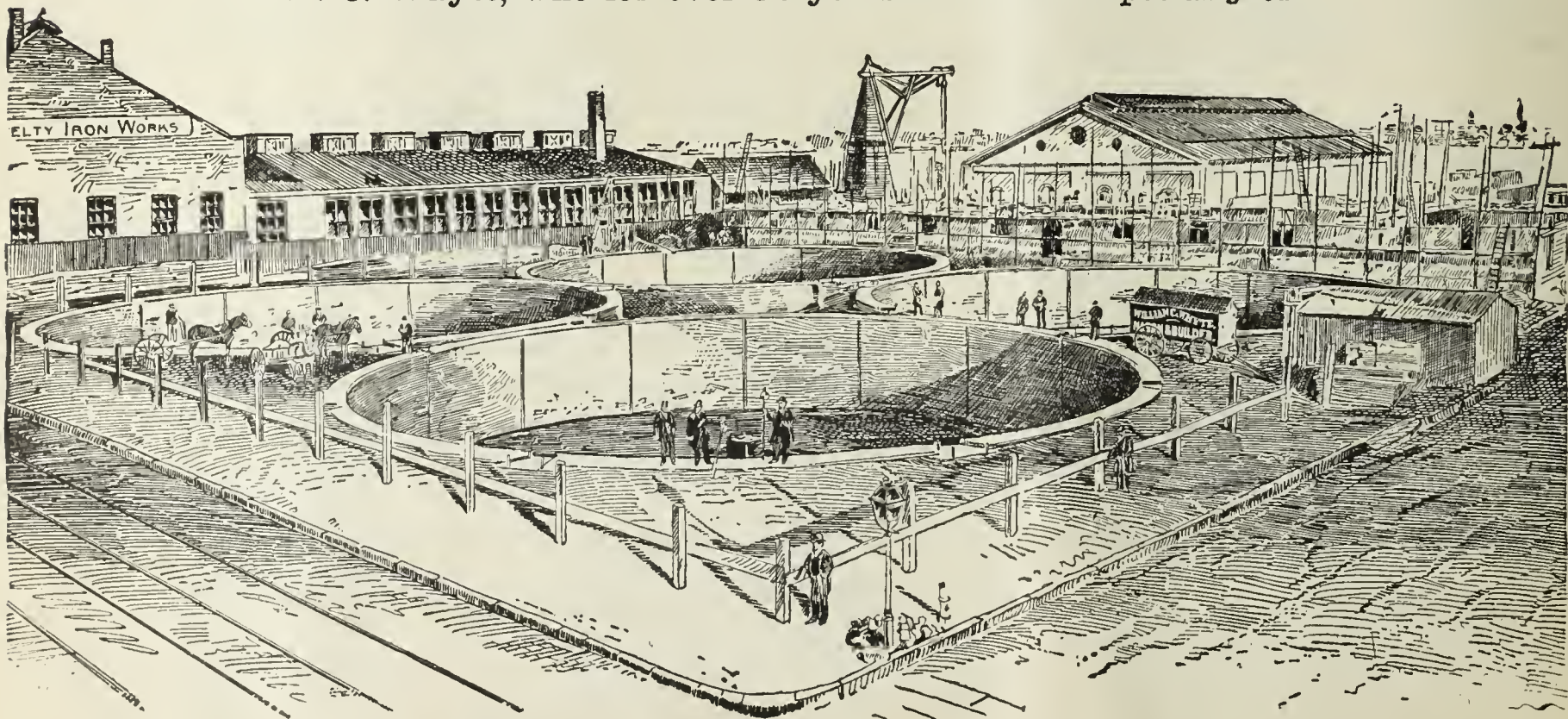

Tank Excavation and Mason Work.

Fifty Tanks now in operation show the sort of work done. Address

W. C. WHYTE, - No. 15 Cortlandt Street, N. Y. City

GAS STOVES.

GAS METERS.

GAS STOVES.

THE AMERICAN METER CO.

Established 1834.

Incorporated 1863.

MANUFACTURERS OF

Gas Meters,

STATION METERS,

METER PROVERS, PHOTOMETERS,

Pressure Gauges of all Kinds,

AND



Standard 3 Diaphragm Dry Meter.



Standard 2 Diaphragm Dry Meter.

Apparatus for Testing the Quantity and Quality of Gases.

GAS STOVES FOR HEATING AND COOKING.



Circulars and Price Lists on Application.

MANUFACTORIES,

508 to 514 West Twenty-second St., N. Y. Arch and Twenty-second St., Phila.
Nos. 244 & 246 North Wells Street, Chicago, Ill.

AGENCIES,

No. 177 Elm Street, Cincinnati, Ohio. No. 222 Sutter Street, San Francisco, Cal.
No. 810 North Second Street, St. Louis, Mo.

GAS STOVE SHOW ROOMS, No. 242 Sixth Avenue, New York City.

THE WALKER TAR AND CARBONIC ACID EXTRACTOR.

A very general demand exists, in both large and small Gas Works, for an apparatus that will be absolutely efficient in the removal of the tar which passes the hydraulic main and condenser. Many attempts have been made to accomplish this, but, I believe, without success, until the introduction, five years ago, in England, of the C. & W. Walker Patent Tar and Carbonic Acid Extractor. During these years this apparatus has been adopted by many of the most prominent Engineers, not only in England, but also on the Continent of Europe and in other parts of the world. It is only necessary to give here a partial list in order to convince any intelligent American Gas Engineer that this machine must have succeeded fully in accomplishing the desired results.

The following Engineers have personally given permission to refer to them:

G. C. Trewby, Esq., Engineer-in-Chief of the Gas Light and Coke Co., London. The manufacturing plant at Beckton is built in complete sections of 3,000,000 cubic feet capacity each. A Walker Tar Extractor has been fitted to each one of these sections. This was done after a long and thorough trial on one of its sections. The Tar Extractor has been supplied to other works of the Gas Light and Coke Co., including those of which John Methven, Engineer of the Gas Light and Coke Co. at the Nine Elms Station, is in charge. Also to G. E. Stevenson, Peterborough Gas Works; B. Green, Mitcham and Wimbledon Gas Works; W. H. Smith, Bedford Gas Works; F. Linging, Norwich Gas Works; J. T. Browning, Colchester Gas Works; S. B. Darwin, Portsmouth Gas Works; J. McCrae, Dundee Gas Works; W. J. Wells, Stamford Gas Works; J. M. Darwin, Longton Gas Works; J. Paterson, Warrington Gas Works; and J. Coulter, of the Dundalk Gas Works. All of the foregoing gas works are located in Great Britain.

Mr. Charles A. Gerdenier, Superintendent of the Bridgeport (Conn.) Gas Light Company, writes as follows, under date of Dec. 3, 1887:

"The C. & W. Walker Tar and Carbonic Acid Extractor has been in operation at these works for the past six weeks, and is an unqualified success. It removes every particle of Tar from the gas in once passing through the apparatus and a large percentage of the Carbonic Acid. I also feel quite sure that it prevents the formation and deposit of Naphthaline, because since I started the Washer I have had no stoppages from this cause. These works have been seriously troubled with Tar for many years, and I have used several kinds of apparatus and every expedient which has come to my attention for dealing with the difficulty, but without success. The Walker apparatus occupies comparatively small space, is less expensive than other systems, and requires but little attention. I carry 2½-inch seal, and have an automatic tar delivery valve. This Tar Extractor is indispensable to gas makers."

I have taken the Agency for the United States for this apparatus, and am now prepared to make contracts to erect it on the premises of any Gas Company. It would be manufactured in the following sizes:

No. 1,	50,000 to	100,000	cu. ft. per 24 hrs.,	3	ft. square,	5	ft. deep.
No. 2,	"	"	"	4	"	"	"
No. 3,	"	"	"	5	"	"	"
No. 4,	"	"	"	6	"	"	"
No. 5,	"	"	"	7	"	"	"
No. 6,	"	"	"	8	"	"	"
No. 7,	"	"	"	9	"	"	"
No. 8,	"	"	"	10	"	"	"
No. 9,	"	"	"	12	"	"	"
No. 10,	"	"	"	15	"	"	"

This Tar Extractor will perform its work with about one-fourth the usual back-pressure heretofore required. It is simple in construction, and can be supplied at a very reasonable price—less than any other ever before introduced. Satisfactory results will be guaranteed in every instance.

GEO. SHEPARD PAGE,

SOLE AGENT FOR THE UNITED STATES,

No. 69 Wall Street, - - - New York

THE UNITED GAS IMPROVEMENT CO.

Drexel Building,

CHESTNUT AND FIFTH STREETS,

PHILADELPHIA, PA.

OFFICERS:

WILLIAM W. GIBBS, President.

EDWARD C. LEE, Sec'y and Treas.

GEORGE PHILLER, Vice-President.

ALEX. C. HUMPHREYS, Gen'l Supt.

SAM'L T. BODINE, Gen'l Manager.

WALTON CLARK, Ass't Gen'l Supt.

RANDAL MORGAN, Gen'l Counsel.

H. II. EDGERTON, Chem. and Eng'r.

DIRECTORS:

GEORGE PHILLER,

HENRY C. GIBSON,

WILLIAM G. WARDEN,

THOMAS DOLAN,

WM. T. CARTER,

SAM'L T. BODINE.

BUILDERS, LESSEES AND PURCHASERS OF

➤ GAS WORKS. ➤

ROOTS' GAS AND BYE-PASS VALVES.

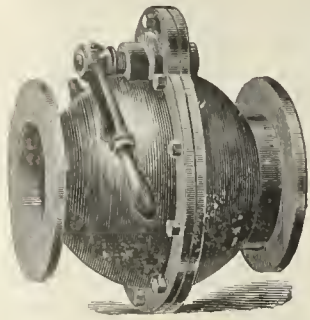

GAS VALVE

Quick Acting,
Simple,
Efficient, Durable.

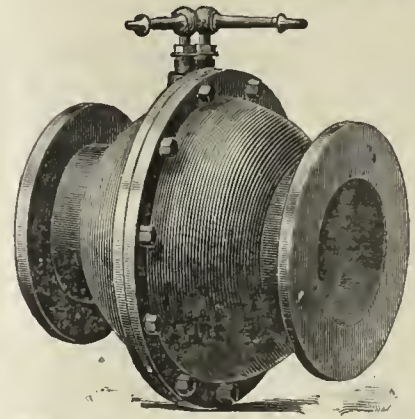

BYE-PASS VALVE.

Automatic Action
Reliable
Simple Durable.

Thousands now in use and giving perfect satisfaction. Write for Catalogue and Prices.

ROOTS' NEW GAS EXHAUSTER.

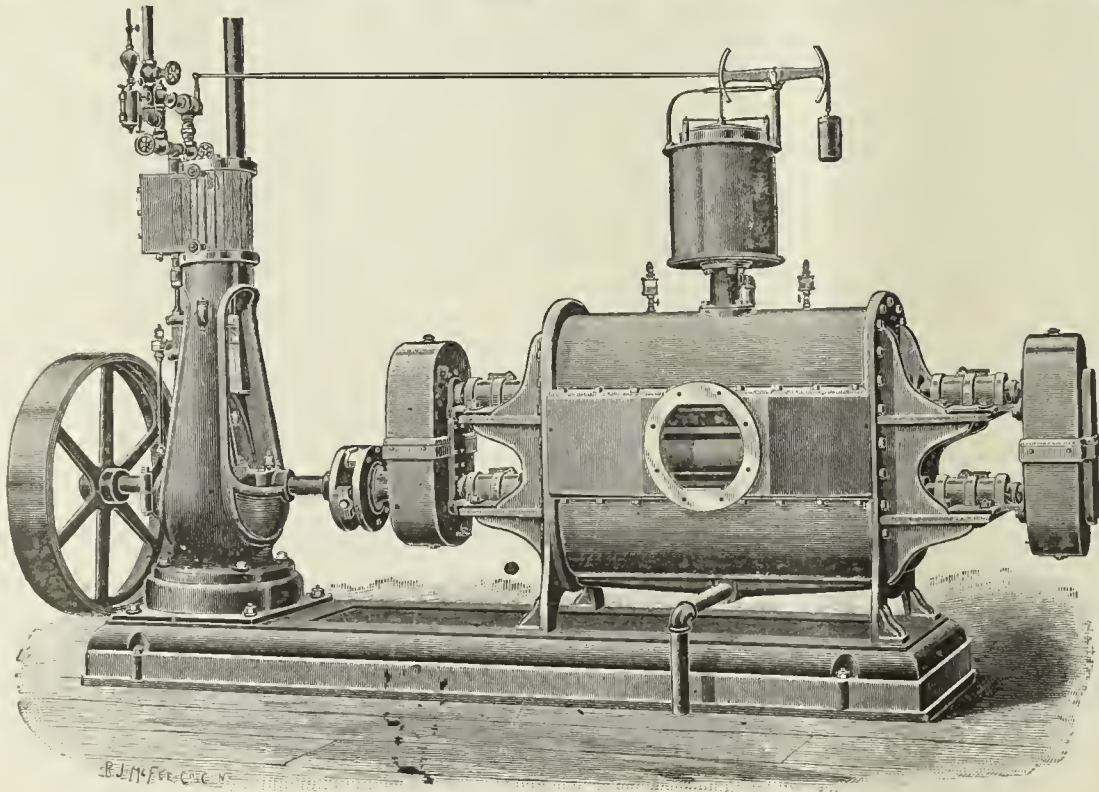

UNSURPASSED FOR

Neatness of Design, Durability, Simplicity, Efficiency, and Economy of Power.

THE ONLY EXHAUSTER MADE WHERE

The Parts Needing Attention are External, and Easily Accessible.

Send for Descriptive Catalogue and Price List.

THE P. H. & F. M. ROOTS CO., Patentees and Manufacturers, **CONNERSVILLE, IND.**

S. S. TOWNSEND, Gen. Agt., 22 Cortlandt St., N. Y.

COOKE & CO., Selling Agts., 22 Cortlandt St., N. Y.

CONNELLY & CO.,

SOLE MANUFACTURERS OF THEIR PATENTED SPECIALTIES.

"IRON SPONGE." Saves money, saves labor, and is the most efficient purifying agent ever offered as a substitute for lime. Now used *in every State in the Union*, and purifying daily over *thirty-five million cubic feet*. Should be used in every gas works. Its own saving will pay for it many times over.

AUTOMATIC GOVERNOR. Has been on the market but *three years*, and in that time has been introduced *more generally* than any invention ever designed for use in gas works. Over *two hundred* of them now in use. Sensitive; reliable; perfectly automatic; reduces leakage; satisfies consumers, and gives great relief to the Manager. No gas works is *complete* without one of these machines.

STEAM JET EXHAUSTER. Designed particularly for small works. Combines Exhaust Tube, Steam Governor Gas Compensator, and Bye-Pass Valves in the most compact form possible; occupies but little space; uses very little steam; operated by ordinary workmen; saves formation of carbon in retorts; increases yield 10 to 15 per cent. Specially adapted for *mixing air* with oil gas. *No works* too small to use them profitably.

Prices given on all our specialties *delivered at any point in the United States*. Correspondence solicited.

CONNELLY & CO., No. 111 Broadway, New York City.

WILBRAHAM GAS EXHAUSTER & ENGINE COMBINED.

WILBRAHAM BROS.,
PHILADELPHIA, PA.

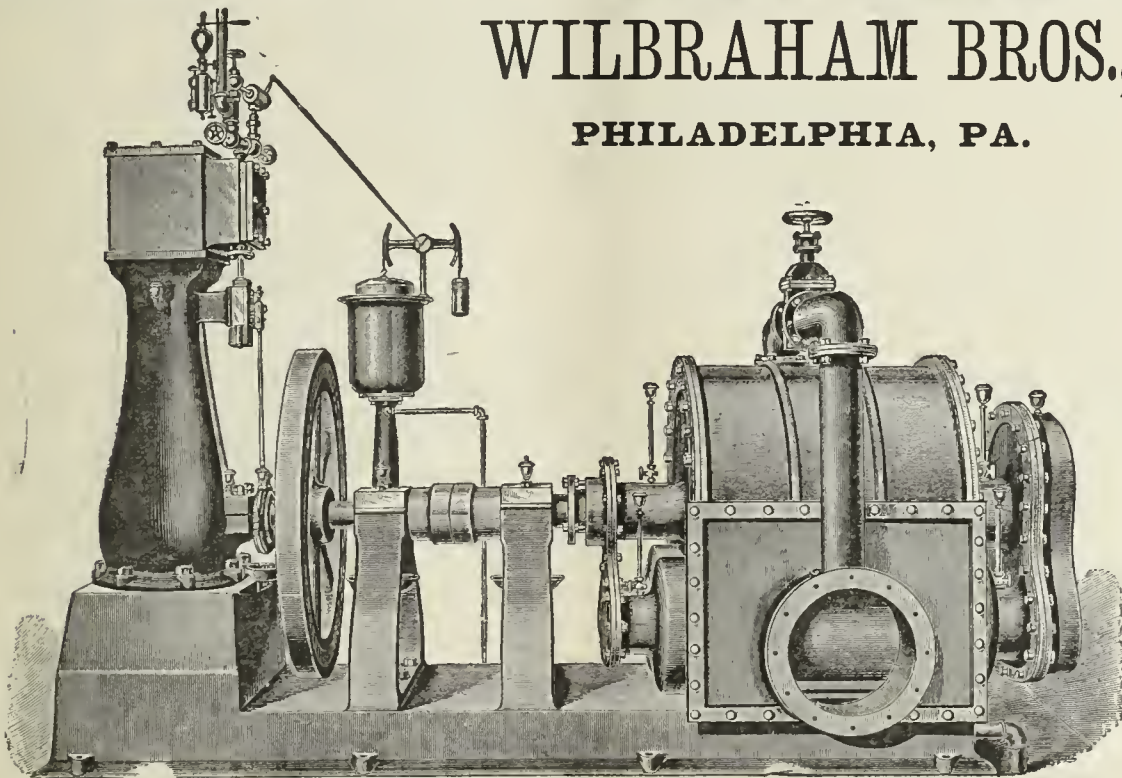

JARVIS ENGINEERING CO.,

61 Oliver St., Boston, Mass.

CONTRACTORS FOR ERECTING

COMPLETE STEAM OUTFITS FOR ELECTRIC LIGHTING STATIONS.

Steel Boilers set with Jarvis Pat. Boiler Setting

To burn **COKE SCREENINGS** for Fuel.

ARMINGTON & SIMS CO. ENGINES,

Belting direct to Dynamos, without using Shafting.

SEND FOR CIRCULARS.

REFERENCES.—Charlestown Gas & Electric Light Co., Charlestown, Mass.; Schenectady Gas & Electric Light Co., Schenectady N. Y.; Brookline Gas Co., Brookline, Mass.

Practical Electric Lighting

By A. BROMLEY HOLMES, A.M.I.C.E.

With 87 Illustrations. Third Edition. Price, \$1.00.

Electric Light Primer.

By CHARLES L. LEVEY.

A simple and comprehensive Digest of all the most important facts connected with the running of the Dynamo and Electric Lights, with Precautions for Safety, etc.

Price, 50 cents.

A. M. CALLENDER & CO., 42 Pine St., N. Y.

Gasholder Tanks & Gas Works Masonry Complete.

PLANS PREPARED AND ESTIMATES FURNISHED AT SHORT NOTICE.

J. P. WHITTIER, - - 499 Wythe Av., Brooklyn, N. Y.

1890 DIRECTORY 1890

OF THE GAS LIGHT COMPANIES of the UNITED STATES & CANADA.

Price, \$5.00.

A. M. CALLENDER & CO., No. 42 Pine Street, N. Y. City.



CHAPMAN VALVE MANUFACTURING CO.,

MANUFACTURERS OF

Valves and Gates for Gas, Ammonia, Water, Etc.

Also, Gate Fire Hydrants With and Without Independent Nozzle Valve. All Work Guaranteed.

WORKS & GEN'L OFFICE:
Indian Orchard, Mass.

TREASURER'S OFFICE:
72 Kilby & 112 Milk Sts, Boston, Mass.

LUDLOW VALVE MFG. CO.

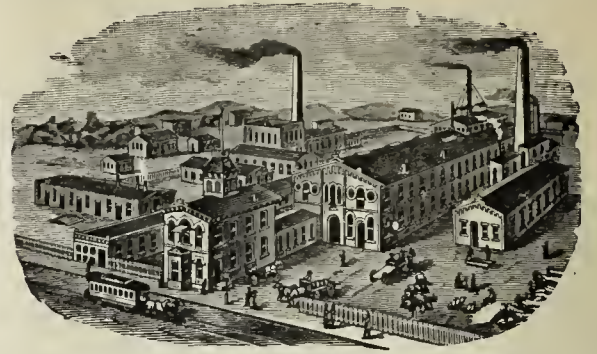

OFFICE AND WORKS,

938 to 954 River Street and 67 to 83 Vail Av.,
TROY, N. Y.

Hydraulic Main Dip Regulators, also
Check Valves, Foot Valves, Yard-
wash and Fire Hydrants.
Send for Circulars.

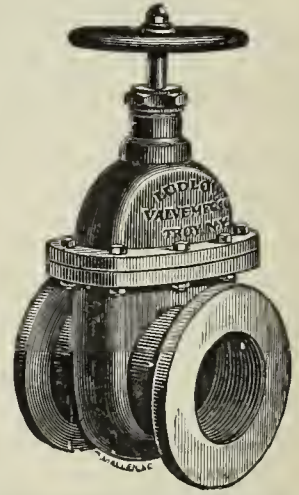

Valves.—Double and Single Gate, 1/2 in. to
48 in., outside and inside Screws. Indica-
tor, etc., for Gas, Water, Steam, and Oil.
Send for Circulars.

Parson's Steam Blower,

FOR IMPROVING BAD DRAUGHT IN BOILERS, AND FOR BURNING BREEZE OR OTHER WASTE MATERIAL.

PARSON'S TAR BURNER,

FOR UTILIZING COAL TAR AS FUEL.

PARSON'S AIR JET TUBE CLEANER,

FOR CLEANING BOILER TUBES.

These devices are all first-class. They will be sent to any responsible party for trial. No sale unless satisfactory. Manufactured by the WATERTOWN STEAM BLOWER COMPANY.

H. E. PARSON. Supt., 33 & 35 Liberty St., N.Y.

MILLS' REVERSIBLE LIME TRAY,

AND

WOODWORK

Of Every Description

NEEDED BY GAS WORKS.

SEND FOR CIRCULAR AND PRICE LIST TO

BARTLETT, HAYWARD & CO.,

Pratt and Scott Streets, Baltimore, Md.

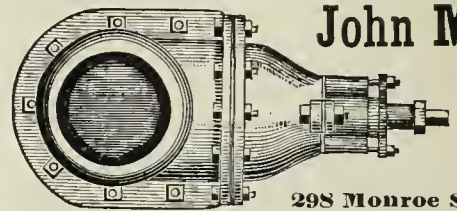
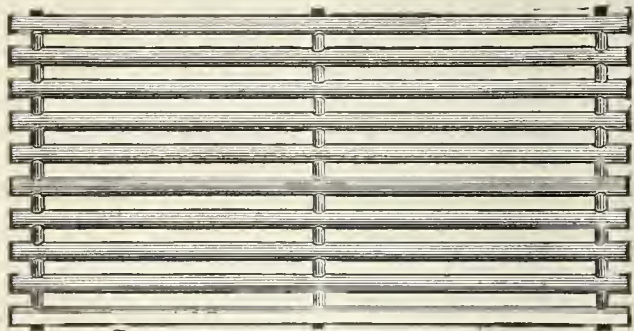

John McLean

Manufacturer

GAS VALVES.

298 Monroe Street, N. Y.

VAN DUZEN GAS & GASOLINE ENGINE

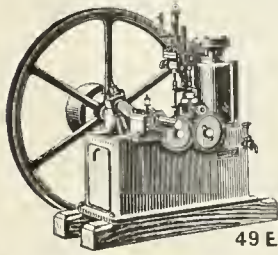

OPERATED with COAL and OTHER MANUFACTURED GASES AND GASOLINE.

RELIABLE AND ECONOMICAL.

Fully Warranted

VAN DUZEN Gas & Gasoline Engine Co. 49 E. 2d St., Cincinnati, O.

A. MacKinnon Machine Co., Agts., 22 Warren St., N.Y.

The Management of Small Gas Works.

BY C. J. R. HUMPHREYS.

Price, \$1.

Orders to be sent to **A. M. CALLENDER & CO.,**

42 PINE STREET, NEW YORK.

SPECIAL TRAYS FOR IRON SPONGE OR OXIDE OF IRON. CHURCH'S TRAYS A SPECIALTY.

REVERSIBLE-STRONGEST-MOST DURABLE-MOST EASILY REPAIRED.

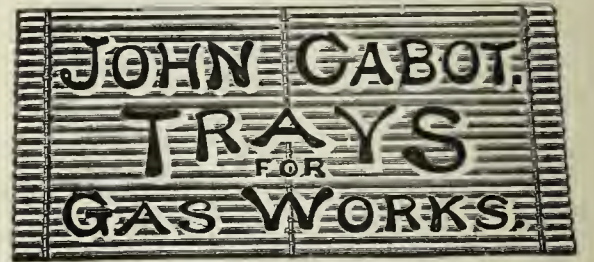

306-310 ELEVENTH AVENUE, NEW YORK.

WE ALSO MAKE THE CHEAPEST AND STRONGEST REVERSIBLE BOLTED TRAYS IN THE MARKET.

THE CLERK GAS ENGINE CO.,

Main Office, 1012, 1014, 1016, 1018 Filbert St., Philadelphia, Pa.

WM. W. GOODWIN, Prest.

E. STEIN, Sec.

S. LEWIS JONES, Asst. Sec.

A. J. DOTY, Supt.

The utility and convenience of the Gas Engine being no longer an open question, it only remains now for intending purchasers to select the BEST. We claim for the CLERK GAS ENGINE that it is equal to any other manufactured as regards steadiness in running, simplicity, and ease of keeping in repair, and that it gives the greatest amount of power for the least money (both in first cost and expense of running) of any engine made. In support of this claim we refer to the test of the Gas Engines made under the direction of the American Institute of New York, in December, 1885, and heretofore published in these columns. These engines are especially adapted for continuous running under heavy loads, and we can refer to Engines which have run 22 hours a day for months at a time!

Made In Sizes of 5 10 15 20, and 25 Horse Power. All Engines Guaranteed for One Year.

ENGINEERS.

P. D. WANNER, Chairman. A. H. MELLERT, Mangr. of Wks.
R. B. KINSEY, Secretary. F. A. KNOPP, Treasurer.

MELLERT FOUNDRY & MACHINE CO. Ltd.
and **READING FOUNDRY CO., Ltd.**
Reading, Pa.



Specials—Flange Pipe, Valves and Hydrants
Lamp Posts, Retorts, etc.
General Foundry and Machine Work.
JOHN FOX, Selling Agent. 160 Broadway, N. Y.

THE OHIO PIPE COMPANY,

MANUFACTURERS OF

Cast Iron Gas & Water Pipe,

BRANCH AND SPECIAL CASTINGS.

Gas-House Bench Castings, Hydraulics, Lamp Posts, Flange Pipe
and Specials, Architectural Castings, Building Columns,
Joists, Cellar Grates, Sash Weights, etc.

GENERAL FOUNDERS AND MACHINISTS.
Columbus, Ohio.

M. J. DRUMMOND,



SPECIAL CASTINGS AND LAMP POSTS.
Office, Corbin Building, 192 Broadway, N. Y.

EMAUS PIPE FOUNDRY.

DONALDSON IRON COMPANY. EMAUS, PA.



MANUFACTURERS OF

CAST IRON PIPE AND SPECIAL CASTINGS
FOR WATER AND GAS.

JOS. R. THOMAS,

No. 42 Pine Street, N. Y. City.

CONSULTING AND CONSTRUCTING

Gas Engineer and Contractor.

PLANS, SPECIFICATIONS, AND ESTIMATES
FURNISHED.

Contracts taken for all Appliances
required at a Gas Works,
Either for New Works or Extensions to Old Plants.

WM. MOONEY

(Successor to WM. FARMER)

No. 94 Liberty St., N. Y. City.

GAS ENGINEER AND CONTRACTOR FOR THE ERECTION
OF GAS WORKS, OR APPARATUS OF ANY
CAPACITY.

Plans and Specifications Furnished.

WM. GARDNER,
Gas Engineer,

Lewis Block, Room 20, Pittsburgh, Pa.

Those who intend to make alterations in existing gas plants, or
who contemplate the erection of new works, will find it to their
interest to open correspondence with the above. Plans made
and estimates furnished.

GAS AND WATER PIPES.

SAM'L R. SHIPLEY, Pres.
HENRY B. CHEW, Tre

GAS AND WATER PIPES.

JAS. P. MICHELLON, Sec.
WM. SEXTON, Supt.

GLOUCESTER IRON WORKS,
GLOUCESTER CITY, N. J.



Cast Iron Gas & Water Pipes, Stop Valves, Fire Hydrants, Gasholders. &c.

Office, Rooms 61 and 63 Bullitt Building, 131 S. 4th St., Phila., Pa.

WARREN FOUNDRY AND MACHINE CO.,

Established 1856. Works at Phillipsburgh, N. J.

New York Office, 160 Broadway.

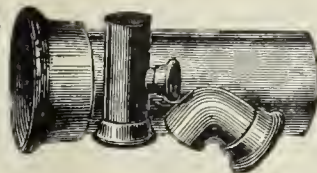

CAST IRON WATER AND GAS PIPE,

FROM TWO TO FORTY-EIGHT INCHES DIAMETER. ALSO, ALL SIZES OF

Flange Pipe for Sugar House and Mine Work. Branches, Bends, Retorts, etc., etc.

DENNIS LONG & COMPANY,

LOUISVILLE, KY.,



CAST IRON GAS & WATER PIPE & SPECIAL CASTINGS
OF ALL SIZES.

King's Treatise on Coal Gas.

A standard text-book for the Engineers and Managers of Gas Works, and for all who are concerned
or take an interest in the manufacture and distribution of Coal Gas, and in the utilization of the
Secondary Products resulting therefrom; treating also of the Gas Engine, and of Gas Cooking and
Heating Appliances.

In 3 Vols. Price per Vol., \$10. Sold either by Volume or in Sets.

A M. CALLENDER & CO., 42 Pine St., N. Y.

RETORTS AND FIRE BRICK.

RETORTS AND FIRE BRICK.

RETORTS AND FIRE BRICK.

J. H. GAUTIER & CO.,

CORNER OF

GREENE AND ESSEX STREETS,

JERSEY CITY, N. J.

MANUFACTURERS OF

**Clay Gas Retorts,
Gas House Tiles,
Fire Bricks, Etc. Etc.**

Ground Clay, Fire Brick and
Fire Sand in Barrels,

J. H. GAUTIER. C. E. GREGORY. C. E. GAUTIER.

BROOKLYN

Clay Retort & Fire Brick Works,

(EDWARD D. WHITE & CO.)

Manufacturers of Clay Retorts, Fire Brick,
Gas House and other Tile.

VAN DYKE, ELIZABETH, RICHARDS & PARTITION STS.

Office, 88 Van Dyke St., Brooklyn, N. Y.

LACLEDE FIRE BRICK MFG. CO.,

MANUFACTURERS OF

Fire Brick, Gas Retorts,

AND

ST. LOUIS STANDARD SEWER PIPE.Blast Furnace and Cupola Linings, every description of Fire
Clay Material, Fire Clay Flue Linings, Chimney Tops
Dry Milled and Crude Fire Clays, etc.

OFFICE AND DEPOT

901, 903, and 905 Pine Street,
ST. LOUIS, MO.

ESTABLISHED IN 1845.

B. KREISCHER & SONS,

OFFICE FOOT OF HOUSTON ST., E. R., N. Y.

Gas Retorts,*TILES, FIRE BRICK.*

AND EVERYTHING IN THE FIRE CLAY LINE.

MANHATTAN

FIRE BRICK & ENAMELLED CLAY

RETORT WORKS**ADAM WEBER.****CLAY GAS RETORTS**

AND RETORT SETTINGS

FIRE BRICKS, TILES, ETC.,

Office and Works, 15th Street and Avenue C., N. Y.



Works,

LOCKPORT STATION, PA.

—ESTABLISHED 1864.—

JAMES GARDNER, JR.,

Successor to WILLIAM GARDNER & SON.

Office, Rooms 19 & 20, Lewis Block,
PITTSBURGH, PA. P. O. Box 373.**Fire Clay Goods for Gas Works.**

H. A. NORTON, No. 4 CENTRAL STREET, BOSTON, MASS., Agent for the New England States.

GEO. C. HICKS,
Prest.**CHICAGO**CHAS. A. REED,
Sec. & Treas.

Retort and Fire Brick Co.,

MANUFACTURERS OF

Fire Clay Goods of all Kinds,

AND BEST QUALITY ONLY.

Regenerative Furnaces & Water Gas Goods.

45th St., Clark to La Salle, Chicago.

GEROULD'S IMPROVED RETORT CEMENT.A Cement for patching retorts, putting on mouthpieces, and
making up all bench-work joints. This Cement is mixed ready
or use. Economic and thorough in its work. Fully warranted
o stick. For recommendations and price list address**C. L. GEROULD & CO.,**

5 & 7 Skillman St., Brooklyn, N. Y.

Western Agent, H. T. GEROULD, Mendota, Ill.

**Parker-Russell
Mining and Mfg. Co.,**

CITY OFFICE,

Mermod-Jaccard Bldg., Rooms 307 & 308,
Broadway & Locust St., St. Louis, Mo.

PROPRIETORS OF THE

OAKHILL GAS RETORT & FIRE BRICK W'KSOur immense establishment is now employed almost entirely in
the manufacture of**Materials for Gas Companies**We have studied and perfected three important points. Our re-
torts are made to stand changes of temperature, the strongest
heats of the furnace, and the abrasion of feeding and emptying.
We have the exclusive Agency for the West of the celebrated**Kloenne-Bredel Full Depth and
Semi-Recuperator Benches,**

And also furnish and build

Our Own Styles Semi-Recuperator Furnaces
for the use of Coal or Coke as fuel.

THOS. SMITH, Prest.

AUGUST LAMBLA, Vice-Prest. & Supt.

BALTIMORE**RETORT & FIRE BRICK CO.**

MANUFACTORY AT

LOCUST POINT, BALTIMORE, MD.

Clay Retorts, Blocks & Tiles**FIRE BRICK, FIRE CLAY,
AND FIRE CEMENT.**Red and Buff Ornamental Tiles and Chim-
ney Tops. Drain and Sewer Pipe (from
2 to 30 inches). Baker Oven Tiles
12 x 12 x 2 and 10 x 10 x 2.

WALDO BROS., 88 WATER ST., BOSTON, MASS

Sole Agents the New England States.

Boston Fire Brick Works Manufacturers of **Gas Retorts and Settings**

Under the Personal Supervision of MR. GEO. C. HICKS late of Chicago.

Fire Clay Goods of all kinds. Akron Sewer Pipe, Lime, Cement, etc. Agts. for the Arc Gas Lamp & Governing Gas Burners.

Send for Circulars and Prices to

FISKE, COLEMAN & CO., Managers, No. 62 Congress Street, Boston, Mass.

HENRY MAURER & SON,
 (ESTABLISHED 1856.)
EXCELSIOR FIRE BRICK & CLAY
RETORT WORKS
 WORKS, Perth Amboy, N. J.
 OFFICE, 418 to 422 East 23d St., N. Y.
Clay Gas Retorts,
BENCH SETTINGS,
 Fire Brick, Tiles, Etc.

FLEMMING'S
Generator Gas Furnace

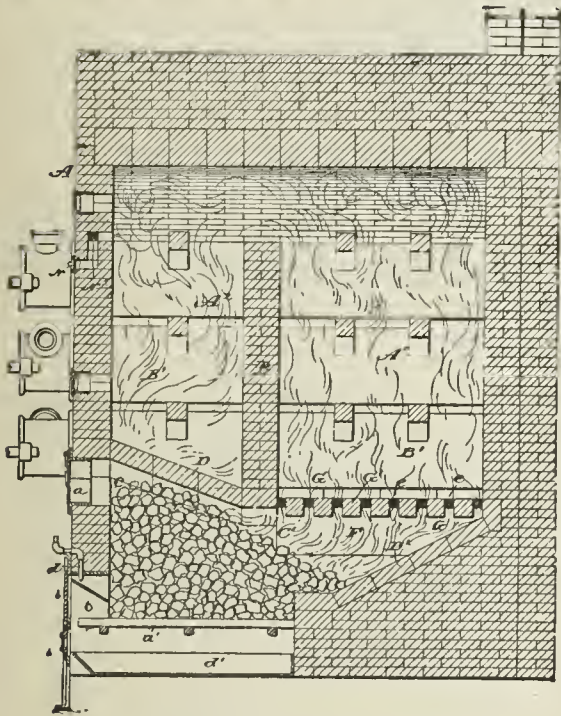

Materials furnished and Benches erected by

J. H. GAUTIER & CO., - Jersey City, N. J.
 Address as above, or D. D. FLEMMING, Jersey City, N. J.

FRED. BREDEL,
 CONTRACTOR FOR THE COMPLETE
Erection and Equipment of Gas Works.
 SOLE PROPRIETOR OF THE
KLOENNE PATENTS
 FOR NORTH AMERICA.

REGENERATIVE FURNACES.

(900 Retorts are now fired in America by the Kloenne-Bredel System.)

SELF-SEALING MOUTHPIECES.

(Over 800 Now in Use.)

Standard Condensers. Washer-Scrubbers.

TAR WASHERS FOR WATER GAS PLANTS.

(In use in the works of the Chicago Gas Lt. Co.)

GASHOLDERS.

Bredel's Automatic Gas Governor.

Refers, by permission, to Mr. Eugene Vanderpool, Newark, N. J.; Mr. E. G. Cowdery, Milwaukee, Wis.; and Mr. Theo. Forstall, Chicago, Ills. For further information, address

FRED. BREDEL,
No. 208 East Seventeenth Street, N. Y. City.

SCIENTIFIC BOOKS.

- | | | |
|---|---|--|
| <p>KING'S TREATISE ON THE MANUFACTURE OF COAL GAS. Three vols.; \$10 per vol.</p> <p>GAS MANUFACTURE, by WILLIAM RICHARDS. 4to., with numerous Engravings and Plates, in Cloth binding. \$12.</p> <p>TECHNICAL GAS ANALYSIS. \$2.80.</p> <p>GAS CONSUMER'S GUIDE. \$1.</p> <p>A GUIDE TO GAS LIGHTING. 40 cents.</p> <p>GAS MEASUREMENT AND GAS METER TESTING, by F. W. HARTLEY. \$1.60</p> <p>GAS CONSUMER'S HANDBOOK, by WILLIAM RICHARDS, C.E.; 18mo., Sewed. 20 cents.</p> <p>A PRACTICAL TREATISE ON GAS AND VENTILATION with Special Relation to Illuminating, Heating, and Cooking Gas, by E. E. PERKINS. \$1.25.</p> <p>PRACTICAL TREATISE ON HEAT, by THOMAS BOX. Second edition. \$5.</p> | <p>GAS WORKS—THEIR ARRANGEMENT, CONSTRUCTION, PLANT, AND MACHINERY. \$8.</p> <p>COAL; ITS HISTORY AND USE, by PROF. THORPE. \$3.50.</p> <p>THE GAS WORKS OF LONDON, by COLBURN. 60 cents.</p> <p>THE GAS FITTER'S GUIDE, Showing the Principles and Practice of Lighting with Coal Gas, by JOHN ELDREDGE. 40 cents.</p> <p>GAS WORKS, AND MANUFACTURING COAL GAS, HUGHES. \$2.20.</p> <p>THE MANAGEMENT OF SMALL GAS WORKS, by C. J. R. HUMPHREYS. \$1.</p> <p>MANUAL FOR GAS ENGINEERING STUDENTS, by D. LEE, 40 cents.</p> <p>HOW TO MANAGE GAS, by F. WILKINS. Paper. 20 cents.</p> <p>THE DOMESTIC USES OF COAL GAS, AS APPLIED TO LIGHTING, by W. SUGG. \$1.40.</p> <p>DIGEST OF GAS LAW. \$5.</p> | <p>DISTILLATION OF COAL TAR AND AMMONIACAL LIQUOR. by GEO. LUNGE. New Edition. \$12.50.</p> <p>A TREATISE ON THE COMPARATIVE COMMERCIAL VALUES OF GAS COALS AND CANNELS, by D. A. GRAHAM 8vo., Cloth. \$3.</p> <p>GAS COMPANIES DIRECTORY. \$3.</p> <p>GAS VERSUS ELECTRIC LIGHT. 50 cents.</p> <p>THE AMERICAN GAS ENGINEER AND SUPERINTENDENT'S HANDBOOK, by WM. MOONEY. \$3.</p> <p>GAS ENGINE INDICATOR DIAGRAM, by W. E. AYRTON. Paper. 20 cents.</p> <p>ILLUMINATING AND HEATING GAS, by W. BURNS. \$1.50,</p> <p>TESTING PIPES AND PIPE JOINTS, by M. M. PATERSON. 80 cents.</p> <p>DESIGNING WROUGHT AND CAST IRON WORK, by H ADAMS. Paper. Three parts, 60 cents each.</p> <p>NOTES IN MECHANICAL ENGINEERING, by H. ADAMS. \$1.</p> <p>STRAINS IN IRONWORK, by H. ADAMS. With plates. \$1.75</p> |
|---|---|--|

The above will be forwarded by express, upon receipt of price. If sent by mail, postage must be added to above prices. We take especial pains in securing and forwarding any other Works that may be desired, upon receipt of order. All remittances should be made by check, draft, or post office money order.

A. M. CALLENDER & CO., 42 Pine Street, New York.

Newbigging's Handbook for Gas Engineers and Managers.

The present (the fifth) edition marks an important advance on those that have gone before. Considerable additions have been made to the text, and much of it has been re-written and otherwise improved. It extends to 524 pages, and contains 193 illustrations. **Price, Cloth, \$6.00.**

A. M. CALLENDER & CO., - - - No. 42 Pine Street, N. Y. City.

DAVIS & FARNUM MFG. CO.,

WALTHAM, MASS.

PRINCIPAL OFFICE AND WORKS, Waltham, Mass.

BOSTON OFFICE, Room 55, Mason Building, 70 Kilby Street.

SINGLE, DOUBLE,
AND
TRIPLE LIFT

Gas holders.

OF ANY CAPACITY.



TUBULAR, PIPE,
AND
SINUOUS FRICTION

Condensers.

OF ALL SIZES.

IRON ROOF FRAMES AND FLOORS.

Purifying Boxes, Center Seal or Valve Connections, Bench Work.

Reversible Lime Trays.

SELF-SEALING AND PRESSED STEEL MOUTHPIECE LIDS.

Coke Barrows, Coal Wagons, and all Apparatus Requisite for a Complete Gas Plant.

— ALSO —

Gas and Water Pipe, Flanged Pipe,

Sugar House Work, and Special Castings of all Descriptions.

Established 1861.

Incorporated 1881.

KERR MURRAY MFG. CO.,

FORT WAYNE, IND.

Those who are in need of

Holdings or Gas Works Apparatus of any Description,

AND OF THE LATEST IMPROVEMENTS,

will find it to their interest to

GET AN ESTIMATE FROM US

before placing their order.

As we make a Specialty of this Class of Work, and are Practical Builders and Manufacturers of same,

with our long years of experience in the business,

WE CAN GUARANTEE YOU SATISFACTION.

Estimates, Plans and Specifications Furnished on Application.

BARTLETT, HAYWARD & CO.

Baltimore, Md.

Triple Double, & Single-Lift
GASHOLDERS.

Iron Holder Tanks.

ROOF FRAMES.

Cirders.

BEAMS.

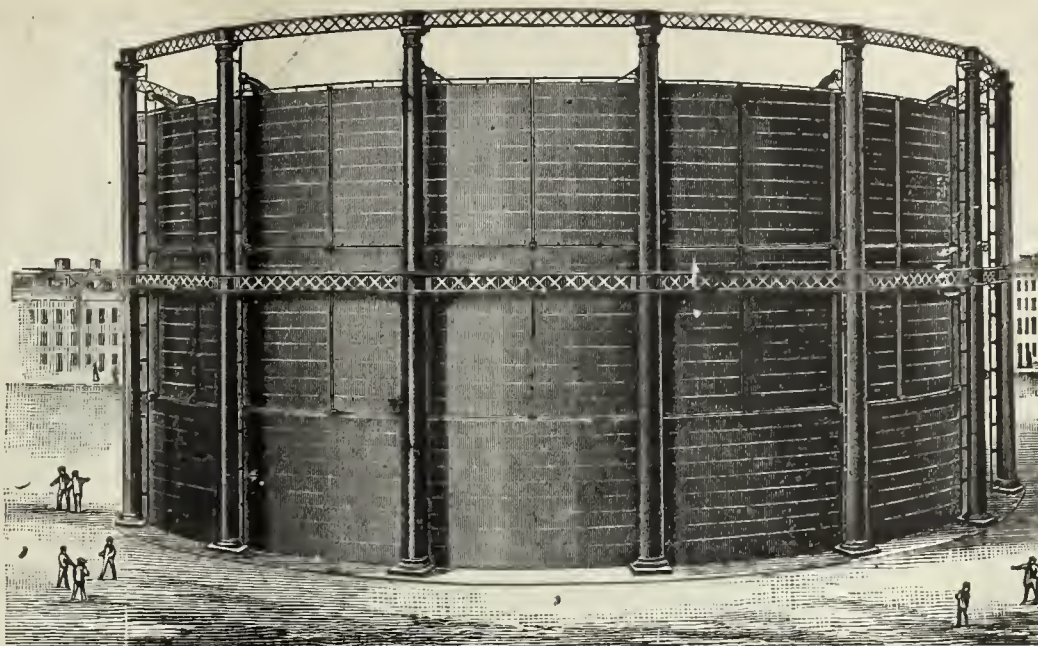

PURIFIERS.

CONDENSERS.

Scrubbers.

BENCH CASTINGS.

OIL STORAGE TANKS.

Boilers.

The Wilkinson Water Gas Process.

THIRTY-CANDLE, NON-CONDENSABLE, FIXED GAS. THE MOST SUCCESSFUL GAS PROCESS IN OPERATION.

Munich Regenerative Furnace, System Drs. Schilling & Bunte.

HAZELTON BOILERS.

Gas Works Designed and Constructed.

Pascal Iron Works. ESTABLISHED 1821. Delaware Iron Works.

MORRIS, TASKER & CO.,

INCORPORATED.

OFFICE, 224 SOUTH THIRD STREET, - - PHILADELPHIA, PA.

CONTRACTORS, BUILDERS, AND MANUFACTURERS OF

Gas, Water & Sugar Works

Bench Castings.

Condensers.

Scrubbers.

Purifiers.

Hyd. Carriages.

Iron Floors,

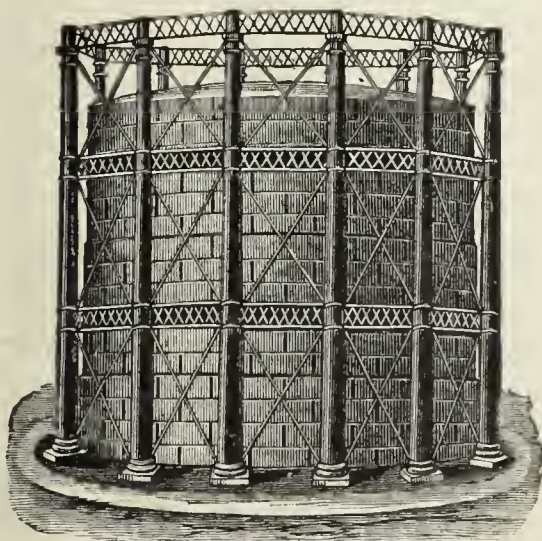

Iron Roofs.

Street Stops,

Valves, etc.

Stand-Pipes.

Water & Oil

Tanks, all Sizes.

Single, Double, and Triple-Lift Gas Holders.

SELF-SEALING RETORT LIDS. STAMPED STEEL RETORT LIDS.

Locomotive Water Columns, Filters, etc. Boiler Tubes, Wrought Iron Pipe & Fittings

Plans, Specifications and Estimates for all kinds of Machinery furnished on application.

Foundries & Works,
MILLVILLE, FLORENCE,
and CAMDEN, N. J.

R. D. WOOD & CO.,

Engineers,
Iron Founders,
and
Machinists.

400 Chestnut St., PHILADELPHIA, PA.

MANUFACTURERS OF

CAST IRON PIPE,

Gas Holders,

SINGLE, DOUBLE, AND TRIPLE LIFTS, WITH
OR WITHOUT WROUGHT IRON
OR STEEL TANKS.

PURIFIERS, CONDENSERS.

Scrubbers.

BENCH WORK.

Iron Floors and Roofs, Plate Girders.

Heavy Loam Castings.

HYDRAULIC WORK.

Lamp Posts, Valves, Etc.

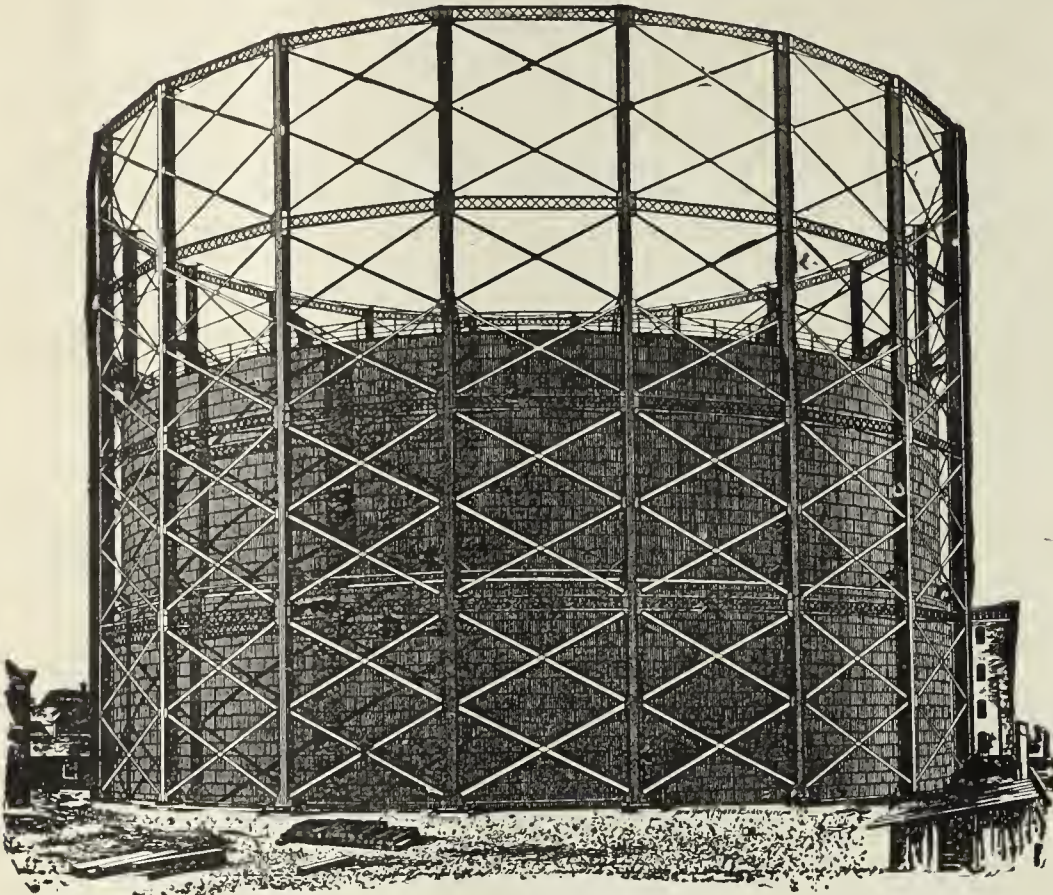

SMITH & SAYRE MFG. COMPANY,

G. G. PORTER, Prest.

245 Broadway, N. Y.

CHAS. W. ISBELL, Sec'y.

Machinery & Apparatus for Gas Works

Drawings, Plans, and Estimates Furnished for the Improvement, Extension, or Alteration of Gas Works, or for the Construction of New Works.

Mackenzie's Patent Rotary and Steam Jet Gas Exhausters, Governors, Compensators, Condensers, Washers, Scrubbers. Isbell's Patent Automatic Street Pressure Governor, Gas and Water Valves, Hydraulic Main Dip Regulator, Bench Castings, etc. Purifying Boxes and "Standard" Scrubbers, Isbell's Patent Self-Sealing Retort Doors.

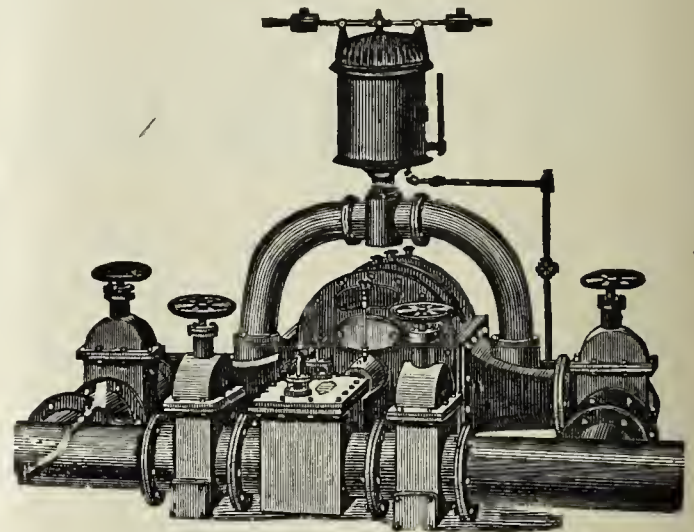

THE BRENNER SELF-SEALING RETORT DOOR.

Simple, Strong, and Durable.

CLOSES ABSOLUTELY TIGHT & IS LOCKED BY A CAM LEVER. ALL NECESSARY ADJUSTMENT FOR WEAR PROVIDED.

BUILT BY

SMITH & SAYRE MFG. CO.,

No. 245 Broadway, - - - New York City.

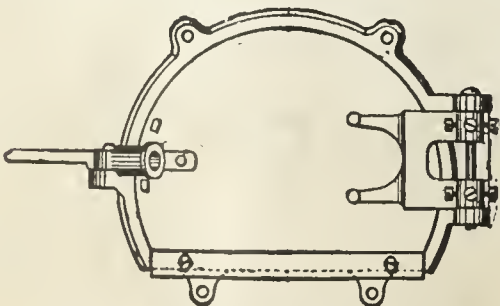

Brenner Self-Sealing Retort Door.

WILLIAM B. LUNDIE, Superintendent of the 42d Street Station of the Consolidated Gas Company, of New York, writes, under date of Jan. 4, 1889:

"We have 320 Brenner Self-Sealing Lids in use at this Station, built by the Smith & Sayre Mfg. Co. They require very little attention, and are the best of the kind that I have seen, giving entire satisfaction."

GAS WORKS APPARATUS AND CONSTRUCTION.

GAS WORKS APPARATUS AND CONSTRUCTION.

JAMES R. FLOYD & SONS,

(SUCCESSORS TO HERRING & FLOYD)

Oregon Iron Works,

W. 20th & 21st. Sts., bet. 10th & 11th Avs.,

NEW YORK CITY.

Engineers and Contractors

FOR THE

CONSTRUCTION OF GAS WORKS.

MANUFACTURERS OF

All Kinds of Castings and General Ironwork

FOR

GAS APPARATUS.

Bench Castings, Regenerative and Half Regenerative Furnace Castings.

Condensers, Scrubbers, Purifiers, Street Drips and Connections,

Valves,

Hydraulic Hoisting Purifier Carriage, Self-Sealing Retort Lids, Improved Valve Stand and Indicator,

Seller's Cement.

Plans, Specifications, and Estimates furnished for Construction of New or Alteration of Old Works.

CONTINENTAL IRON WORKS.

THOS. F. ROWLAND, Prest.

WARREN E. HILL and CHAS. H. CORBETT, V-Prests.

THOS. F. ROWLAND, JR., Sec. & Tr

P. O. Station G., BROOKLYN, N. Y.

ENGINEERS AND MANUFACTURERS OF

Gas Holders

CONDENSERS, SCRUBBERS, VALVES,

PURIFIERS, SELF-SEALING RETORT LIDS

Hydraulic Mains,

And all other articles connected with the manufacture and distribution of Gas.



H. RANSHAW, Prest. & Mangr.

WM. STACEY, Vice-Prest.

T. H. BIRCH, Asst. Mangr.

R. J. TARVIN, Sec. & Treas.

STACEY MFG. CO.,

MANUFACTURERS OF

Single and Telescopic Gasholders,

IRON ROOFS, BRIDGES, LAMP POSTS,

Water and Oil Tanks, Coal Elevator Cars,

COKE CRUSHERS, BENCH CASTINGS,

And all kinds of Wrought and Cast Iron Work used in the erection of Coal and Oil Gas Works, Rolling Mill Machinery and Heavy Castings a Specialty.

Foundry:

83, 35, 37 & 39 Mill Street.

Wrought Iron Works:

16, 18, 20, 22, 24 & 26 Ramsey Street:

Cincinnati, Ohio.

Bouton Foundry Co.,

FOUNDERS AND MACHINISTS,

CHICAGO, ILL.

Gas Works Apparatus,

PURIFIERS, CONDENSERS,

Bench Work

SPECIALS, LAMP POSTS,

SCRUBBERS,

Iron Roofs and Floors.

Plans and Estimates furnished for new works or extensions of old works.

1842. **DEILY & FOWLER,** 1890.

Laurel Iron Works.

Address, No. 39 Laurel Street, Philadelphia, Pa.

BUILDERS OF

GASHOLDERS,

Single and Telescopic.

Holdings Built 1884 to 1888, Inclusive:

- | | | | | |
|----------------------------|-----------------------------|---------------------------|--------------------------|------------------------|
| Newport, R. I. | Long Island City, N. Y. | Port Chester, N. Y. | Malden, Mass. | West Chester, Pa. (2d) |
| Portland, Oregon. | Macon, Ga. | New Rochelle, N. Y. | Paducah, Ky. | Lancaster, Pa. (3d) |
| Allegheny, Pa. (2d.) | York, Pa. | Salem, N. J. (3d) | Norwich, Conn. | Tac-n-y, Pa. (two) |
| Atlanta, Ga. (2d.) | Chester, Pa. | Omaha, Neb. (2d) | Seattle, W. T. | Mount Vernon, N. Y. |
| N.Y. City (Central Gas Co) | Hazleton, Pa. (2d.) | Lynn, Mass. (2d) | San Diego, Cal. | Binghamton, N. Y. |
| Lynchburg, Va. (2d.) | Staten Island, N. Y. | Little Rock, Ark. | Northern Gas Lt. Co., of | Concord, N. H. |
| Saylesville, R. I. | Saugerties, N. Y. | Irrington, N. Y. | New York, N. Y. | Dover, Del. (2d) |
| Rondout, N. Y. | Clinton, Mass. (Lan. Mills) | South Boston, Mass. | Westerly, R. I. | Calais, Me. |
| Atlantic City, N. J. | Chattanooga, Tenn. | Rye, N. Y. (2) | Willimantic, Conn | New London, Conn. (2d) |
| Augusta, Ga. | Galveston, Texas. (3d.) | Woodstock, Ont. | Montclair, N. J. | West Chester, N. Y. |
| Waltham, Mass. (2) | Omaha, Neb. | Malden, Mass. | Attleboro, Mass. | Bay Shore, L. I. |
| Mahanoy City, Pa. | Fort Plain, N. Y. | Staten Island, N. Y. (2d) | Santa Cruz, Cal. | Washington, D. C. |
| New Castle, Pa. | Brunswick, Ga. | Woodstock, Ont. | Erie, Pa. (2d) | |

WM. HENRY WHITE,

No. 32 Pine Street, - - - New York City.

ENGINEER AND CONTRACTOR FOR THE

ERECTION AND EXTENSION OF

GAS, WATER, AND ELECTRIC LIGHT WORKS.

Correspondence with Gas Companies contemplating extending or improving their Plants respectfully invited.

Plans and Estimates Furnished.

GAS COALS.

CANNEL COALS.

GAS ENRICHERS.

JAMES D. PERKINS. **PERKINS & CO.,** F. SEAVERNS.
228 & 229 Produce Exchange, New York.

Cable Address, "PERKINS, NEW YORK."

Post Office Box 3695, New York.

GENERAL SALES AGENTS FOR

The Youghiogeny River Coal Company's

OCEAN MINE YOUGHIOGHENY GAS COAL.

HON. W. L. SCOTT, Prest. M. H. TAYLOR, Vice-Prest.

This Colliery is located at SCOTT HAVEN, PA., in the center of the Youghiogeny Gas Coal District, and produces the ONLY RELIABLE YOUGHIOGHENY COAL for gas purposes. (See Map on p. 87 of this JOURNAL, Feb. 16, '85.)

POINTS OF SHIPMENT,

Locust Point, BALTIMORE.

Pier No. 62, PHILADELPHIA.

Also, SOLE AGENTS for the

**BRECKENRIDGE CANNEL,
OF KENTUCKY.**

Within the past two years we have delivered this Cannel to over ONE HUNDRED COMPANIES IN THIRTY-THREE DIFFERENT STATES, and it is now in use in some of the large Gas Works

On the Continent and in South America,

where it successfully competes with the Australian Shale. It is the ONLY AMERICAN GAS CANNEL of sufficiently high grade to warrant EXPORTATION TO EUROPE AND SOUTH AMERICA, and it is the only economical substitute for OIL OR NAPHTHA. ONE GROSS TON will produce

10,000 Cubic Feet of 75 Candle Gas,	} equal to {	750,000 Candle Feet of Gas, and 26 Bushels
or 12,500 " " 60 " "		of merchantable Coke weighing 900 Pounds
or 15,000 " " 50 " "		

This is the ONLY GAS CANNEL that will produce a REALLY MERCHANTABLE COKE. It can be delivered in parcels of one carload or more to any point in the United States or Canada. Cargo shipments of any size required can be made from NEW YORK, PHILADELPHIA, BALTIMORE, or NEWPORT NEWS. Samples will be sent and particulars of price, etc., forwarded upon application to above address.

JAMES & WILLIAM WOOD,
Gas and Cannel Coal Contractors,

No. 40 St. Enoch Sq., Glasgow. No. 2 Talbot Court, London.

Proprietors of the BATHVILLE COLLIERIES (which produce the celebrated BOGHEAD CANNEL), Shields, Shieldmuir, Drumpeller, and other Collieries. This Firm offer

STANDARD CANNELS,

Unequaled as Gas Enrichers.

Also, WEST FAIRMONT GAS COAL, of W. Va.

Analyses, prices, and all further information furnished on application to

Agency for U. S., Room 70 Nos. 2 & 4 Stone St., N.Y. City.

The Standard Oil Company,

REFINERS OF

NAPHTHA AND GASOLINES.

ALSO MANUFACTURERS OF

A Special Grade of Naptha for Gas Companies

FOR ENRICHING COAL GAS.

Correspondence solicited.

No. 43 Euclid Avenue, Cleveland, Ohio.

To Gas Companies.

We make to order CAP BURNERS to burn any amount under a stated pressure. Send for samples.

Also, SERVICE CLEANERS, DRIP PUMPS, and STREET MAIN PROVING APPARATUS.

O. A. GEFROHER,

248 N. 8th Street, Phila., Pa.

COKE CRUSHERS.

GAS COALS.

GAS COALS.

Newburgh Orrel Coal and Coke Co.

MINERS AND SHIPPERS OF

STEAM, SMITHING, AND GAS COALS,
Foundry and Crushed Coke.

Home Office, 33 S. Gay Street, Baltimore, Md.

J. HARRY LEE, President.

Shipping Wharves, Locust Point, Baltimore.

The Despard Gas Coal Co.,

MINERS AND SHIPPERS OF

DESPARD GAS COAL,

AND MANUFACTURERS OF

COKE.

MINES, Clarksburg, Harrison Co., W. Va.

WHARVES, Locust Point, Baltimore, Md.

OFFICE, 225 E. German St., " "

ROUSSEL & HICKS, } AGENTS. } BANGS & HORTON,
71 Broadway, N. Y. } 60 Congress St., Boston.

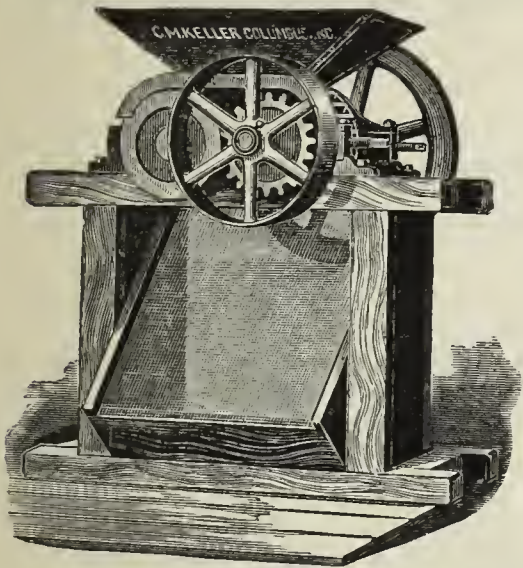

Keller's Adjustable Coke Crusher.

SIMPLE, STRONG, AND DURABLE.

C. M. Keller, Sec. & Supt. Gas Lt. & Coke Co. Columbus, Ind.

Correspondence Solicited.

King's Treatise on Coal Gas.

The most complete work on Coal Gas ever published.

Three Vols. Bound, \$30.

BOOKS.

DISTILLATION OF COAL TAR AND AMMONIACAL LIQUOR.

By GEORGE LUNGE. Price \$12.50.

A TREATISE ON THE COMPARATIVE COMMERCIAL VALUES OF GAS COALS AND CANNELS.

By DAVID A. GRAHAM. 8vo., Cloth. Price \$3.

Orders for these books may be sent to this office.

A. M. CALLENDER & CO.,

42 PINE ST., N. Y. CITY

THE PENN GAS COAL CO.

OFFER THEIR

Coal, Carefully Screened & Prepared for Gas Purposes.

Their Property is located in the Youghiogheny Coal Basin, near Irwin and Penn Stations on the Pennsylvania Railroad, and on the Youghiogheny River.

Principal Office:

209 SOUTH THIRD STREET, PHILA., PA.

Points of Shipment:

Pennsylvania Railroad Piers; Greenwich Wharves, Delaware River; Pier No. 1 (Lower Side), South Amboy, N. J.

Chesapeake & Ohio Railway Coal Agency,

FOR THE SALE OF THE

Superior Kanawha Gas Coals, Cannelton Cannel,
Also, SPLINT AND STEAM COALS,
From the Kanawha and New River Regions, on the line of the Chesapeake & Ohio R'way.

C. B. ORCUTT, General Agent, - - No. 1 Broadway (Room 217) New York City.

FRANCIS H. JACKSON, Prest.

EDMUND H. MCCULLOUGH, V.-Prest.

CHAS. F. GODSHALL, Treas.

H. C. ADAMS, Sec.

THE WESTMORELAND COAL CO.

Chartered 1854.

Mines situated on the Pennsylvania and the Baltimore and Ohio Railroads, in Westmoreland County, Penn.

POINTS OF SHIPMENT:

PHILADELPHIA, BALTIMORE, SOUTH AMBOY, N. J.,
WATKINS (SENECA LAKE), N. Y.

Since the commencement of operations by this Company its well-known Coal has been largely used by the Gas Companies of New England and the Middle States, and its character is established as having no superior in gas-giving qualities, and in freedom from sulphur and other impurities.

Principal Office, 224 South 3d St., Phila., Pa.

The American Gas Engineer and Superintendent's Handbook.

By WILLIAM MOONEY.

Consisting of Rules, Reference Tables, and Original Matter Pertaining to the Manufacture, Manipulation, and Distribution of Illuminating Gas.

350 Pages, Full Gilt Morocco.

\$3.00.

A. M. CALLENDER & CO., 42 Pine St., N. Y.

JOHN J. GRIFFIN & CO.,

Nos. 1513, 1515, 1517 & 1519 Race Street, PHILADELPHIA.
52 Dey St., NEW YORK. 75 N. Clinton St., (FRED. R. PERSONS, Mangr.) CHICAGO.

MANUFACTURERS OF

METERS FOR MEASURING GAS

IN ANY VOLUME.

Provers, Gauges, Registers, Etc., Etc.

EXPERIMENTAL APPARATUS FOR QUANTITATIVE AND QUALITATIVE ANALYSIS.

Careful and Prompt Attention paid to Repairing of all kinds of Meters and Apparatus.

Estimates Cheerfully Furnished.

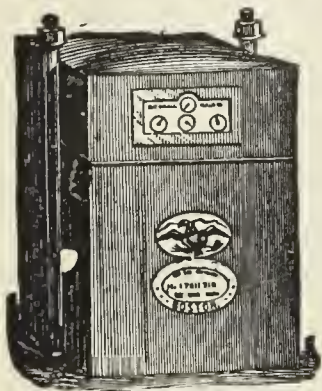

Dry Gas Meters.

With 40 years' experience and the best facilities for manufacturing, is enabled to furnish reliable work and answer orders promptly.

NATHANIEL TUFTS,

No. 153 Franklin Street, Boston, Mass.,

MANUFACTURER OF

DRY GAS METERS.

Station Meters of any Capacity.

Test and Experimental Meters, Pressure Registers, Pressure Gauges, Pressure and Vacuum Gauges.

METER PROVERS, PHOTOMETERS, STREET LANTERNS, ETC., ETC.

Patent Cluster Lanterns for Street Illumination.

HAROLD J. BELL.

BELL & JONES,

S. LEWIS JONES.

No. 12 North Ninth Street, Philadelphia, Pa. Works at Royersford, Pa.

MANUFACTURERS OF

GAS METERS, STATION AND EXPERIMENTAL METERS,
Meter Provers, Pressure Gauges, and All Other Gas Appliances in Our Line.

WE REPAIR ALL KINDS AND MAKES OF METERS, AND THE WORK GUARANTEED.

High Pressure Meters for Natural Gas, in Iron Cases, guaranteed to stand 300 lbs. Pressure.
Gas Cooking and Heating Stoves, Hot Plates, Cake Griddles, Waffle Bakers, Boiling Stoves, Laundry and Tailors' Iron Heaters. Hotel and Cafe Ranges a Specialty.

Correspondence Solicited.

Estimates Furnished.

A. HARRIS.

E. L. HARRIS.

J. A. HARRIS.

Established 1849.

HARRIS BROS. & CO.,

Twelfth and Brown Streets, Philadelphia.

Manufacturers of Wet and Dry Gas Meters,

STATION METERS, METER PROVERS,

EXPERIMENTAL METERS, SHOW OR GLAZED METERS,

Pressure and Vacuum Registers, Gauges, Photometers, Drip and Bell Pumps, Etc., Etc.

PROMPT ATTENTION GIVEN TO ALL ORDERS. METERS THOROUGHLY REPAIRED. ESTIMATES FURNISHED FOR STATION METERS OF ALL SIZES. CORRESPONDENCE SOLICITED.

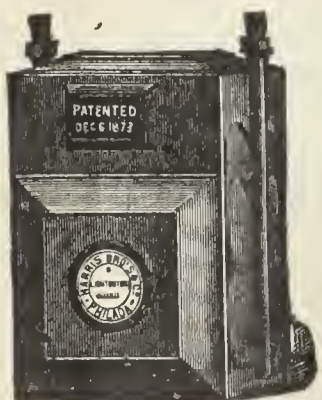

GAS METERS.

GAS METERS.

GAS METERS.

GEO. J. MCGOURKEY, Prest.

WM. H. MCFADDEN, Vice-Prest. (Phila.)

WM. N. MILSTED, Gen. Supt. and Treas. (New York).

WM. H. DOWN, Sec.

THE AMERICAN METER CO.

Established 1834.

Incorporated 1863.

WET AND DRY GAS METERS.

PRESSURE REGISTERS.

METER PROVERS.

STATION METERS.

PRESSURE & VACUUM REGISTERS.

PORTABLE TEST METERS.

EXHAUSTER GOVERNORS.

PRESSURE & VACUUM GAUGES.

EXPERIMENTAL METERS.

DRY CENTER VALVES.

CRESSON GAS REGULATORS.

AMMONIA TEST METERS.

GOVERNORS FOR GAS WORKS.

MARSLAND WATER METERS.

BAR & JET PHOTOMETERS.

Manufactories:

512 West 22d St., N. Y.
Arch & 22d Sts., Phila.

GAS STOVES.

SUGG'S "STANDARD" ARGAND BURNERS,
SUGG'S ILLUMINATING POWER METER,
Wet Meters, with Lizar's "Invariable Measuring" Drum.

Agencies:

177 Elm Street, Cincinnati.
244 & 246 N. Wells Street, Chicago.
510 North Second Street, St. Louis.
222 Sutter Street, San Francisco.

HELME & McILHENNY,

(Established 1848.)

GAS METER MANUFACTURERS,

Nos. 1339 to 1349 Cherry Street, Philadelphia, Pa.,

WET AND DRY GAS METERS. STATION METERS, EXPERIMENTAL METERS, METER PROVERS,

Center Seals, Pressure Registers, Governors, Indicators, Photometers, and all other kinds of Apparatus for use in Gas Works.

FOULIS' PATENT STATION AND DISTRICT GOVERNORS.

REPAIRING DEPARTMENT.—We employ a special force of skilled workmen repairing meters of all makers.

WM. WALLACE GOODWIN, President and Treasurer.

E. STEIN, Vice-President.

H. B. GOODWIN, Secretary and Superintendent.

THE GOODWIN GAS STOVE AND METER CO.

Successors to W. W. GOODWIN & CO.

1012, 1014 and 1016 Filbert St., Phila., Pa.

113 Chambers St., New York City.

76 Dearborn, St., Chicago, Ill.

WALDO BROTHERS, Agents, 88 Water Streets, Boston, Mass.

MANUFACTURERS OF

DRY AND WET GAS METERS,

Station Meters (square, cylindrical, or in staves), Glazed Meters, King's and Sugg's Experimental Meters, Lamp Post Meters, etc., etc.

Provers (sizes 2, 5, and 10 feet), Pressure Gauges of all kinds, Pressure Registers, Pressure and Vacuum Registers, Pressure Indicator

(sizes 4, 6, and 9 inch), King's Pressure and Vacuum Gauges, Dry and Wet Center Seals, Dry and Wet Governors, Exhauster

Governors, Photometers of all descriptions. Letheby's Sulphur and Ammonia Test Apparatus complete. Also, Testing

and Chemical Apparatus of all kinds, and of the most perfect description, for all purposes relating to Gas.

Manufacturers of the "SUN DIAL" GAS STOVES, for Cooking and Heating.

Goodwin's Improved Lowe's Jet Photometer.

Agents for Bray's Patent Gas Burners and Lanterns.

Special attention to Repairs of Meters and all Apparatus connected with the business. All work guaranteed first-class in every particular. Orders filled

G. B. EDWARDS, Manager, New York.

S. S. STRATTON, Manager, Chicago.

D. McDONALD & CO.,

GAS METER MANUFACTURERS

(Established 1854.)

51 Lancaster St., Albany, N. Y.

34 & 36 West Monroe St., Chicago, Ill.

STATION METERS, EXPERIMENTAL METERS, METER PROVERS, PRESSURE & VACUUM REGISTERS, PRESSURE GAUGES

Also STAR GAS STOVES, RANGES, and HEATING STOVES

We use only the very best materials, and employ the most skilled labor, and by our long experience (36 years) and personal supervision of our work we feel justified in assuring the public that our goods will give perfect satisfaction. Every Meter emanating from our establishment will bear the Inspector's BADGE, and will be fully warranted by us. Our Annual and Calendar will be sent to Gas Companies upon application.

WM. WALLACE GOODWIN, President. E. STEIN, Vice-President. H. B. GOODWIN, Sec. & Supt. G. B. EDWARDS, Mang'r, New York. S. S. STRATTON, Mang'r, Chicago.

THE GOODWIN GAS STOVE AND METER CO.,

1012-18 Filbert St., Phila., 113 Chambers St., N. Y., 76 Dearborn St., Chicago.

Agents, WALDO BROTHERS, 88 Water Street, Boston.

SOLE MANUFACTURERS OF THE

"SUN DIAL" GAS STOVES,

The Most Economical, Efficient, and Durable Gas Stove Made.

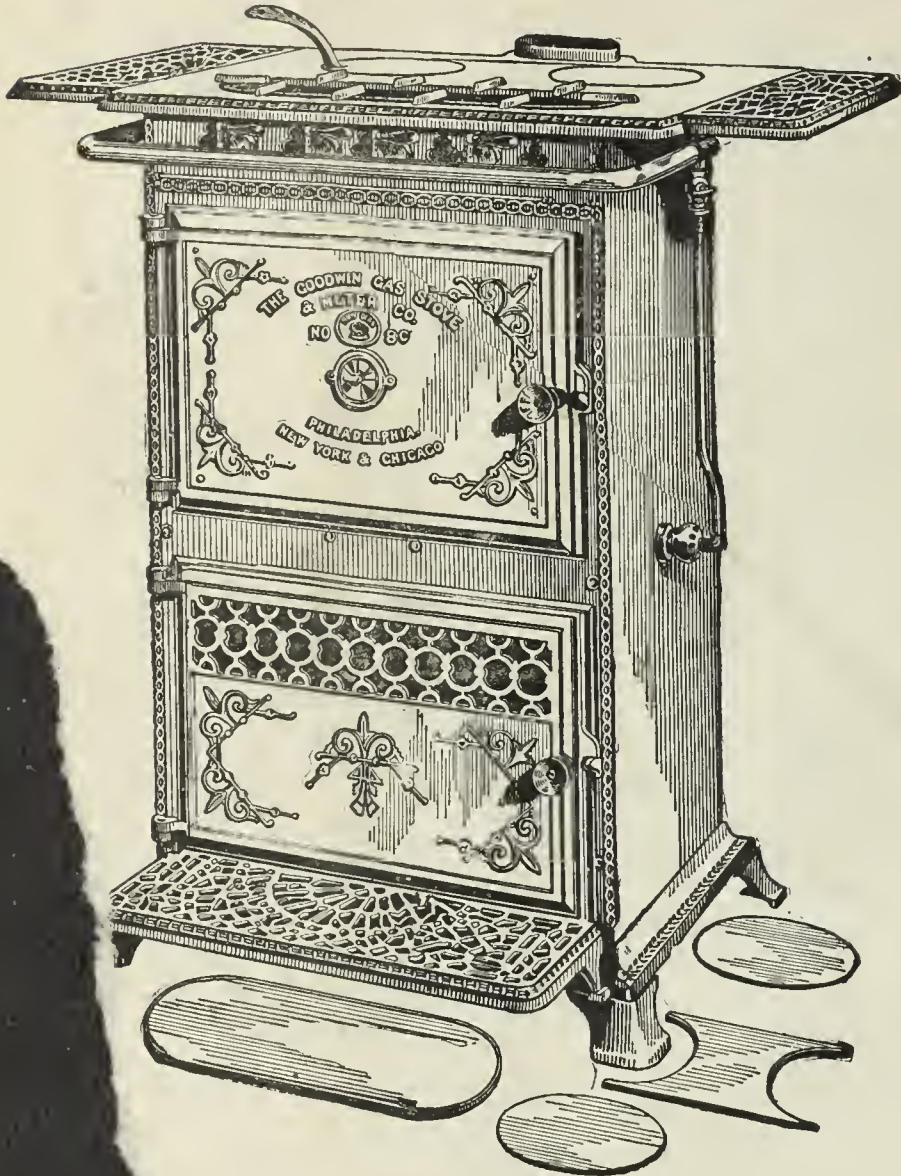

GAS COOKING STOVE, No. 8 C.

SIZE.

Oven.	Roaster.	Top.	Length over Extension Shelves,
12 in. high.	12 in. high.	24 in. long.	36 in.
17 1/2 in. wide.	18 in. wide.	21 in. wide.	
12 in. deep.	13 in. deep.		

Has four burners on top, and double oven burner. Consumption of gas with all burners in use, 42 feet per hour, at 1 inch pressure. The front and oven door are made in sections, so that a greater variety of cooking utensils may be used. The oven door has covers and crosspieces and putting in a suitable forked ring, which is used for hanging a wash boiler or other large utensil may be set over two burners. A RIDDLE also fits in the same position. The roasting oven is provided with a door.

Front and Oven Door are Nickel-Plated.

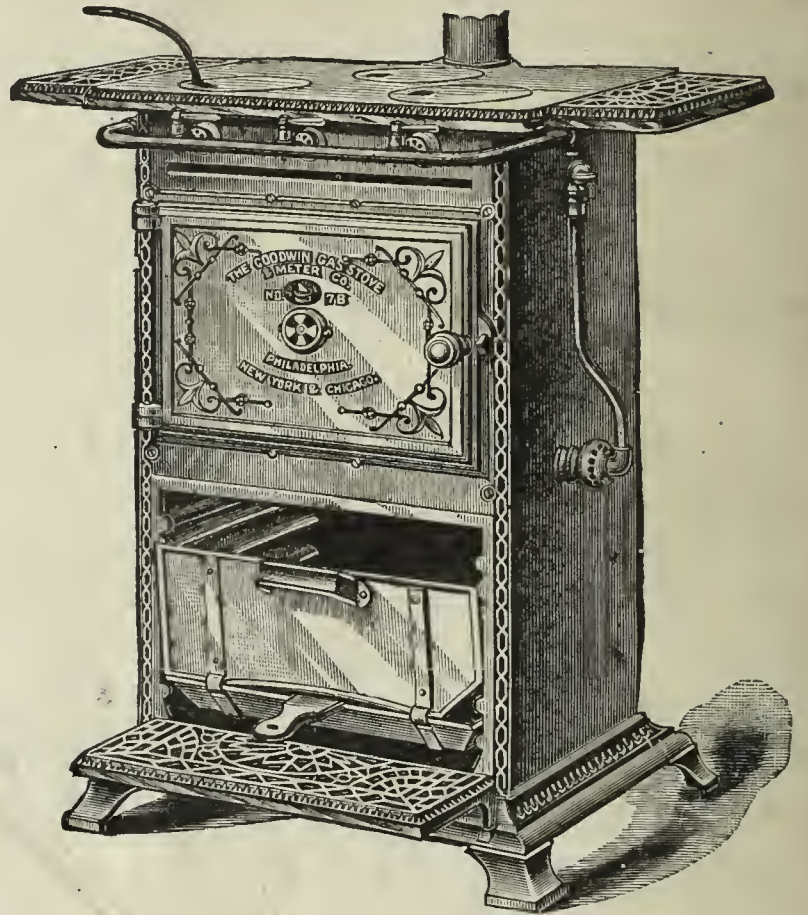

GAS COOKING STOVE, No. 7 B.

SIZE.

Stove.	Oven.	Roaster.	Top.	Length over Extension Shelves,
31 in. high.	9 1/2 in. high.	10 in. high.	21 in. long.	32 in.
17 in. wide.	14 1/2 in. wide.	15 in. wide.	16 in. wide.	
	12 in. deep.	13 in. deep.		

This Stove has three boiling burners in the Top or Hot Plate, and one single oven burner.

This cut represents our New Style Cooking Stove. As will be seen, it has an ornamented cast-iron Base and Front, and extension shelves. The Oven Burner, which is atmospheric (unless otherwise ordered), is of an entirely new and improved pattern (patent). The ovens are of greater capacity than those of the old style. The Top, in conjunction with the Outlet Pipe, is designed to carry off all the products of combustion, if desired, but they are also supplied with a loose ring which converts it into an ordinary open top stove.

The consumption of this Stove is 35 cubic feet per hour at 1 inch pressure, with all burners in use.

All Fittings are Nickel-Plated.

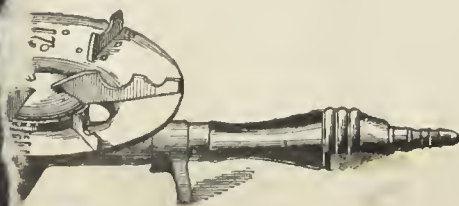

BOILING STOVE, WITH ORNAMENTATIVE BURNER.

Consumption, 6 feet

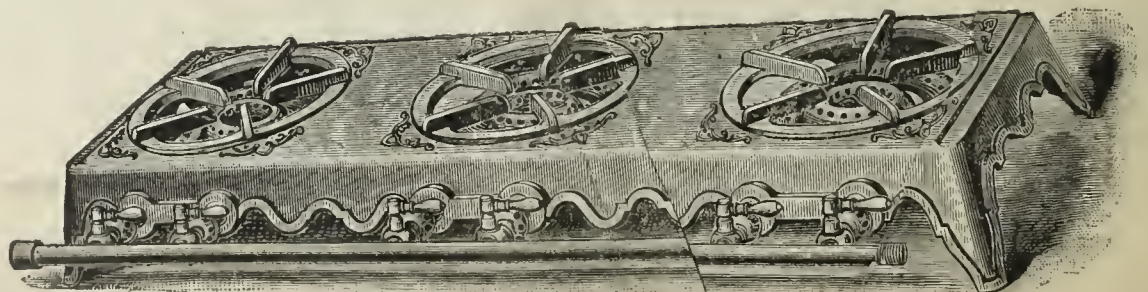

HOT PLATE, No. 11.

Size, 36 in. long, 12 in. wide, with three double burners, 6 tips. Consumption, with all burners in use, 36 cubic feet per hour, with 1 in. pressure. 1/2 in. supply pipe should be used where the pressure is 1/2 in. or over.

THE AMERICAN

GAS LIGHT JOURNAL

REDHANKENNY, N.Y.

PUBLISHING OFFICE No. 42 PINE STREET

DEVOTED TO THE INTERESTS OF ILLUMINATION, VENTILATION, WATER SUPPLY AND DISTRIBUTION, & GENERAL SCIENCE.

VOLUME LII.—No. 22. }
Whole No. 782.

NEW YORK, MONDAY, JUNE 2, 1890.

{ \$3 PER ANNUM,
IN ADVANCE.

A. M. CALLENDER & CO., Proprietors. C. E. SANDERSON, Manager.
JOS. R. THOMAS, C.E., Editor. T. J. CUNNINGHAM, Asst. Editor.

ENTERED AT THE POST OFFICE AT NEW YORK, N. Y.
AS SECOND CLASS MATTER.

Published on each Monday of the year, at No. 42 Pine Street, N. Y.

Terms of Subscription, Including Postage.—For the United States and Canada, \$3 per annum. European countries, \$4.50 (19 shillings—22½ francs). All payments to be made in advance. Single copies, 10 cents.

Remittances should be made either by post-office order, registered letter, or bank draft on New York, payable to the order of A. M. Callender & Co.

Collections are invariably made directly from this office, for subscriptions, advertisements, etc. We have agents to solicit the same, but they are not authorized to receipt for money.

Correspondence.—Wishing to make this JOURNAL a gazette of intelligent discussion to those of our readers who may wish to gain or give information on the subjects to which its columns are devoted, correspondence is solicited for publication from all who make the study of those subjects a pleasure or a profession.

The American News Company, Nos. 39 and 41 Chambers street, New York, are agents for this JOURNAL. Newsdealers will send orders to them.

Books.—We will forward by express, at publisher's lowest rates, any book—scientific or otherwise—to any address in the United States or Canada. No book will be sent C. O. D.

CONTENTS.

An Asterisk (*) denotes an illustrated article.

OFFICIAL NOTICE—

Meeting of Council, American Association..... 765

EDITORIALS—

The Western's Thirteenth Annual..... 765

Notes..... 766

Thirteenth Annual Meeting Western Gas Association—Official Report..... 766

First Day, Morning Session: Roll Call—President's Address—Postponing the Election of New Members—Report of Board of Directors—Appointment of Special Committees—Mr. Gimper Surprises the Chair—Report of Treasurer—Reading the Papers—On the Abuse of the Patent System as Bearing on the Gas Industry: with a Remedy, by Frederic Egner—Discussion.

The Chemistry of the Dinsmore Process..... 774

Oil in India..... 774

Resistance to Fire of Wood Posts..... 774

ITEMS OF INTEREST FROM VARIOUS LOCALITIES..... 775

Annual Meeting, Rockland, Me.—Sale of the Moberly (Mo.) Plant—Hints from Macon, Ga.—Another Opinion—Public Lighting at Summit, N. J.—Personal—Annual Meeting, Winona, Minn.—Annual Meeting, Portland, Me.—Contracts for the Berlin Bridge and Iron Company—Omitted from the Programme—The Chicago Gas Company—Gas for Cooking at Minneapolis, Minn.—Plant Improvement at Pottstown, Pa.—Public Lighting, Chester, Pa.—Lectures on Gas Cooking, Des Moines, Ia.—McGuire's Fuel Gas Company—Mr. Frost Receives a Watch and Chain—And Many Other Items.

The Market for Gas Securities..... 777

AT a meeting of the Council of the American Gas Light Association, held on the evening of May 21st, at the Lindell Hotel, St. Louis, Mo., the following committees were appointed:

Committee on World's Fair.—Messrs. A. B. Slater, W. H. White, C. J. R. Humphreys, W. H. Pearson, A. E. Forstall, A. W. Littleton and J. P. Harbison.

Committee to Nominate Officers for Next Year.—Messrs. Thomas Turner, A. B. Slater, Jr., A. W. Littleton, J. F. Scriver and W. H. Denniston.

THE WESTERN'S THIRTEENTH ANNUAL.

We can, we fear, say but little that is new to our readers, respecting the St. Louis Convention of the Western Association, in that "Three Stars" availed himself so freely of the wire to furnish the main particulars of what was concededly one of the best meetings ever held by the Western. In the first place, the weather was good, albeit some of the hours were rather hot; the attendance was inspiring; the meeting hall excellent, and the gentlemen in charge of the arrangement details indefatigable. As for what might be considered or classed as the "outside convention"—that is, the exhibition of gas apparatus and the pleasuring trips—no words of praise can be too warm in expressing an opinion as to the complete success of these. To go back a trifle. President Faben occupied a peculiarly odd position, in that he presided over an assemblage whose predecessors of a twelvemonth had selected a man of exceptional popularity to guide its deliberations of this year. But the Great Authority decreed that Edward J. King should not carry out the will of his fellows, and so the mantle of direction was laid on the shoulders of a man who wore it worthily and well. Indeed it is not too much to say that in Mr. Faben the Association had an executive that could not have been surpassed. Exact, impartial and alert, his firm handling of the reins directed, but without strain, the travel of business routine. His address, which is given in another column, contains much that is of more than passing interest, and we hope that the chapters on "Electric Light," "Enriching Material" and "Legislation" will be closely studied. Perhaps the second and third divisions will appeal most strongly to the gas makers, in that each presents an important point for consideration—the one involved in manufacture, the other bound up with the very commercial existence of our craft. Lima crude oil, with all its faults, has been loved by the gas makers for its cheapness as an enricher, but that wonderful corporation—the Standard Company—which controls it is evidently not disposed to slip its opportunity for profit over its sale in future, as an advance of 100 per cent. in the price of the product at the mouth of the wells during the last few months amply testifies. The needs of the purchasers, however, regulate prices, and so we suppose the situation must be accepted at its face. In the other instance we are pleased to note the heartiness with which Mr. Faben indorses the soundness of the policy of the formation of State Gas Commissions. Such hammering cannot fail to make an impression of the right nature. Mr. Faben's tribute to those whom death claimed as his own from the Western's ranks during the year, brief though it is, is so beautifully framed that we will not mar it by any extended expression of our concordance with it. And this leads us to say

that the *In Memoriam* proceedings, both in the reports of the committee and the oral expressions uttered after their formal presentation to the meeting, were extremely impressive. Dark, indeed, was the death roll of the Association in the twelvemonth, but beautiful were the sympathies evoked from its bitter memories. This thought leads us on to the general excellence of the Special Committee work performed in the interim of the last meeting. The report of Committee on Gas Company Accounts is a model one, and carries on its face a lengthy record of labor and application. The paper list bore out the promise of its lines, and we congratulate the Association on the literary capacity of its members. In other numbers we may take the liberty of referring to the papers at greater length; for some of them certainly seem to call for comment. As remarked before, the exhibition of gas apparatus was a grand success. The goods were tastefully arranged, the exhibits were profuse, and every detail of management, both for the service of the exhibitors and the comfort of those who attended the display, was as it should be. Take it in any sense, the Western's meeting, in its business aspect, was an unqualified success. We shall have more to say about the gas exhibition at another time.

And as it was with the purely business side of the meeting so also was it with the social feature. We imagine we are not far wrong in our verdict that the banquet was not missed; but then, again, every city cannot boast of a river front of 16 miles on one of the river wonders of the world. However, the business of the session having terminated at the appointed hour on Thursday, the members and their guests were conveyed in carriages to the Washington avenue wharf, where the commodious and elegantly-appointed excursion steamer *Oliver Bierne* was boarded. How delicious the soft breezes from the broad bosom of the Father of Waters were in their searching ministrations, and how well did they succeed in their mission of cooling the heated and reinvigorating the wearied. The course was up the river as far as the fantastic Chain of Rocks, which permitted a view of the Eads and Merchant's bridges and the new water works, all tributes to the commercial greatness and growth of busy St. Louis. A feature of the up-trip was the reception that greeted the excursionists when passing the works of the Laclède Company. Every whistle on the works shrieked forth a welcome, and the grimy workmen, ranged on shore, joined in the chorus with their cheers. In fact you would not think that such a thing as a "strike" could ever have occurred or ever would occur in that vicinity. And from the heartiness of the response from those who thronged the steamer's decks one would not suppose that any demand that could be made by the men would ever be refused. More's the pity, then, that things are not always what they seem. On the return trip the steamer passed Carondelet, thus giving the excursionists a bird's-eye view of St. Louis' noble river front. It goes without saying that none could complain of lack of goods for the inner man, and those who would a dancing go had the inspiration of "fairy strains of music falling" to guide their twinkling steps. The committee, including particularly the "Russell Brothers," seemed to be ubiquitous. Home was reached at a seasonable hour, and all retired, anxious for the morrow with its renewal of the round of pleasure. Friday morning came at last, and with it the carriages that were to convey the visitors through the city and to the Fair Grounds on the west. St. Louis may not be Chicago, but it nevertheless abounds in fine buildings and handsome drives; and, take it all-in-all, we rather think "it will do" as either a good place to do business in or a spot wherein to make one's home. The Fair Grounds reached, an elegant luncheon was served in the Jockey Club House, and at 2:30 the horses were summoned to the post for the first race. The excitement over the "programme" culminated in the contest for the "Western Gas Association Cup," a magnificent and costly trophy in solid silver, donated by the Committee of Entertainment. The race was gallantly won by "Harry Clark," some of the boys insisting that the name of the steed as registered on the "correct card"—Churchill Clark—was a misprint. The day and its festivities were flawless, and the return to the Lindell was made in season sufficiently early to enable the early birds to board the evening trains. A feature of the proceedings was the "watching" of Chairman R. D. Walsh, of the Committee of Arrangements, who will hereafter be easily able to note the flight of time. Now that it is all over, we can say with satisfaction and truth that the Western's "Thirteenth" was an unqualified success. "Is gas the light of the present?" "Yes." "Is it to be the light of the future?" "Beyond a doubt."

NOTES.—The Elizabethtown (N. J.) Gas Light Company will sell gas at \$1.50 per 1,000 on and after July 1st.—Michael Murphy, who had been many years in the service of the Toledo (O.) Gas Company, died on May 24th. He was in his 48th year.

[OFFICIAL REPORT.]

THIRTEENTH ANNUAL MEETING OF THE WESTERN GAS ASSOCIATION.

HELD AT ST. LOUIS, MO., MAY 21, 22 AND 23, 1890.

FIRST DAY—MORNING SESSION—MAY 21.

The Thirteenth Annual Meeting of the Western Gas Association was held at the Lindell Hotel, St. Louis, Mo., beginning Wednesday, May 21, 1890. The President of the Association, Mr. Edward J. King, having died within the year, the First Vice-President, Mr. C. R. Faben, Jr., of Toledo, Ohio, took the chair, and called the meeting to order at 10 o'clock A.M. In opening the session the President said:

By the death of Mr. King, the gentleman whom you saw fit to honor with the presidency of this Association last year, it devolves upon me to preside over the meeting at this time. I am thoroughly conscious of the duties and responsibilities of the position, and I appreciate the honor which you did me last year by naming me First Vice-President. It will be my aim and endeavor to serve you well, and if I fail to do so it will not be through want of effort. With these few remarks I now declare the Convention open for the transaction of such business as may properly come before it.

ROLL CALL.

During the session the following members responded to their names:

Honorary Members.

Harbison, John P.	Leach, H. B.	Thomas, Joseph R.
Humphreys, C. J. R.	Slater, A. B.	White, Wm. Henry.

Active and Associate Members.

Adams, C. F.	Griffin, J. J.	Post, I. S.
Ambrose, J. S.	Harper, H. D.	Powell, A. W.
Averill, A. T.	Harris, Joseph A.	Pratt, E. G.
Baxter, I. C.	Hess, C. E.	Printz, Eugene.
Bedard, F. W.	Higgins, W. H.	Ramsdell, Geo. G.
Bradley, C. D.	Howard, J. B.	Rice, E. S.
Bredel, Fred.	Howard, L. J.	Roots, D. T.
Butterworth, C. W.	Jenkins, E. H.	Runner, Z. T. F.
Canby, R. H.	Johnston, W. J.	Russell, D. R.
Chollar, B. E.	Jones, C. D.	Schuster, Paul F.
Clark, Walton.	Judge, W. H.	Scofield, L. K.
Collins, Carroll.	Keller, C. M.	Shelton, F. H.
Connelly, T. E.	Knight, C. S.	Smallwood, J. B.
Cressler, A. D.	Lansden, T. G.	Smythe, A. E.
Cowdery, E. G.	Lindsley, Edward.	Somerville, James.
Daniels, James.	Littleton, A. W.	Spencer, R.
Davis, Daniel.	Lynn, J. T.	Stacey, William.
Dell, John.	McDonald, Wm.	Starr, J. M.
Diall, M. N.	McIlhenny, John.	Steinwedell, Wm.
Down, W. H.	Mayer, F.	Stout, John.
Dunbar, J. W.	Mitchell, K. M.	Stratton, S. S.
Egner, Frederic.	Montgomery, James.	Stratton, R. J.
Elbert, V. L.	Morgans, W. H.	Taylor, Thos. E.
Faben, C. R., Jr.	Murdock, George T.	Thompson, Geo. T.
Ferrier, James.	Murdock, J. W.	Thompson, J. D.
Forstall, A. E.	Newman, Chas. V.	Tracy, Wm.
Freese, F. W.	Newman, Wm. A.	Van Wie, P. G.
Fullagar, W. E.	Odiorne, W. H.	Veal, Enoch.
Gerould, H. T.	Osius, George.	Walbridge, H. D.
Gimper, John.	Payne, M. J.	Walsh, R. D.
Goodwin, W. W.	Perkins, B. W.	Watts, Sylvester.
Gordon, J. J.	Perkins, N. C.	Whipple, H. S.
Green, James.	Persons, F. R.	

On motion of Mr. Howard, the reading of the minutes of the previous meeting was dispensed with.

President Faben here read the following

INAUGURAL ADDRESS.

Gentlemen of the Western Gas Association: Another year has passed into history, and with it the record of our individual successes and failures. We come together this day to the thirteenth annual meeting of our Association, armed with the valuable lessons learned by the experience of another year; with greater knowledge, better judgment and firmer convictions upon all matters pertaining to the business that we represent. Let us, therefore, make good use of the valuable material acquired since last we met in convention, remembering also that this can

best be done by full, free and thorough exchange of information between members.

The true condition and promise of the gas industry at the present time are certainly favorable; and this, in the presence of the fact that never before in the history of our business have we had the sharp competition in the field of lighting as at present, is of itself strong evidence of the desirability of gas as a source of light for all common purposes.

The present prosperous condition of the gas industry is largely the result of good business management of our affairs; not any one thing or act of and by itself will account for our continued prosperity, but constant study and inquiry, and prompt application of every device and suggestion that tend either to reduce the cost of manufacture and distribution, or improve the quality of our product, or create a market for the same, each and every item that is a contributing factor to our success, must be given the proper credit.

To learn of the success or failure, as the case may be, the result in practical operation of the many different devices offered, and practice suggested, and, also, to make and receive further suggestions, are the objects of the present business meeting of the members of the Western Gas Association.

Processes.—The past year has not been rich with startling development of new types of apparatus, nor radical changes in existing plans of operation; yet we have progressed. We have improved in many small matters of detail, and have progressed toward that goal that we call perfection. We have dismissed a large measure of the prejudice that formerly moulded many of our expressed convictions, even though we may have held at the time an honest opinion to the contrary, yet, on account of our prejudice, we would not give it expression in our utterances.

Water gas is one subject that clearly illustrates to what extremes our prejudice may lead us. The successful application of electricity as a source of light is another. To-day we speak of and regard these projects in an entirely different manner than formerly.

Electric Light.—The electric light as a competitor to gas, for purposes of light, presents a solid front. The arc light has established itself as the best means of lighting large areas, and for street lighting purposes it has no equal. The incandescent electric light is making good, fair progress in many places, and I might say generally. It presents some few advantages over gas that the promoters never fail to appreciate, and they always call the attention of possible patrons to these various little advantages. A naked flame is a dangerous thing to have exposed in many situations that gas jets have been used, and with the incandescent electric lamp quite a display is often made in show windows, stores and private houses, with the light placed and distributed in some unusual manner, the effect of which is novel and at once taking to the average person.

How very profitable to investors these electrical undertakings may be, I question. From statements recently made I find that out of about 100 electric lighting companies in Massachusetts only 15 declared dividends in the past year. Of these 15 companies 10 declared dividends of from 1 to 6 per cent., and only 5 declared dividends above 6 per cent. Leaving out the Boston companies, which by reason of the extent and value of their territory enjoy a greater demand for their light than exists in smaller places, the average of dividends paid by the electric light companies in the State, who paid dividends at all, has been only 4.9 per cent.

Another fact in this connection is that no fund has been created by these several electric light companies to compensate for wear and tear. No depreciation has been charged off. The usual and necessary repair is supposed to represent all of the depreciation, so that the dividends paid are virtually taken from the plant itself or its value. Electric light companies are opposed to having any depreciation charged off other than the cost of repairs and renewals actually made.

The use of the incandescent electric light has demonstrated to my mind the tendencies of the times in the matter of distribution of light. A few years ago many consumers of gas complained of the light produced from burning gas, that it was not of sufficient intensity, and they resorted to the arc light. In many of these situations since that time the arc light with all of its intensity and other desirable qualities has been discarded, and a great number of incandescent electric lamps are used in its stead, so that the present tendency seems to be in the direction of the use of a large number of small lights for indoor illumination, giving to the general illumination something more of a starry effect.

The custom or practice with incandescent electric light companies, in the matter of computing and establishing rates for lighting service, is certainly faulty. No matter how careful and conscientious a consumer may be, the privilege to the free and unlimited use of an article of light leads to great wastefulness. This wastefulness is an item of ex-

pense to someone, and, under the conditions cited, it must be a very serious item to the producer.

The question of whether or not gas light companies should engage in the supplying of electric light is a purely business proposition, and is determinable only by local conditions. In some situations, yes; in others, no.

Enriching Material.—The development of the Ohio oil fields led to the adoption of some type of water gas apparatus by many of the formerly strictly coal gas companies. The crude oil was sold at a very low price, and, with suitable apparatus, was a very cheap and desirable material for carbureting water gas. The price of this material, as well as the situation generally, has changed materially during the past few months. The price of Ohio oil has increased more than 100 per cent. at the wells, and the supply of this material is well under the control of one corporation. This corporation has no desire to sell crude oil for gas making purposes at any price. As I am informed, they intend to take from the crude oil the light products, and sell the residuum for fuel oil. The light products will be split up into gasoline for the stove trade, and naphtha for use by gas light companies for carbureting purposes.

If my information is correct we are at once confronted with a situation where the cost of material used for carbureting water gas will be nearly doubled in the average situation. The whole subject is entitled to the serious consideration of each interested member. Ohio oil may be worth intrinsically all that is asked for it, but at the present time, when gas light companies are working in every manner and employing every means to reduce the cost of producing gas, the sudden rise in the market value of any material, or, as suggested, the taking out of the market entirely the material desired or required in producing gas is certainly of serious moment.

Legislation.—The great agitation that is being made throughout our country by individuals in some places, and by many individuals banded together in the large centers, calling themselves Nationalists, who are advocating the "establishing of public water, gas and electric light works, to make the street railways municipal property, to work for general State laws permitting municipalities to assume these functions without special legislation, and ultimately forbidding them to be exercised by private corporations," is a subject well worthy of serious consideration by us at this time.

These are, of course, but a few of the "reforms" that the "Nationalists" contemplate; but as the industry we represent stands almost first among the industries that they wish municipalities to own and operate, it would be well for us to consider what real reform would be the most practical.

To my mind a "State Gas Commission," similar to the one now in successful operation in the State of Massachusetts, suggests itself as the most practical method of deciding all questions in dispute arising between municipal corporations and gas light companies.

If it were possible to render a "perpetual and exclusive franchise" to a gas light company, with a State Gas Commission as the arbitrator, whose decision was final, how much better it would be for both the investor in gas undertakings and the gas consumer.

The investor would have a permanent investment at a fair rate of interest, and the consumer would buy gas, of good quality, at a much lower price than is possible under the present conditions.

The number of bills that have been introduced within a reasonable time in the Legislatures of the different States, that are of serious interest to the gas light companies operating in those States, clearly indicates that some sort of legislation is being demanded by the people. The necessary legislation demanded will be enacted even though a number of "acts" are passed and experimented with before a satisfactory measure is finally adopted.

As we are more familiar with the situation than either the majority of our law makers or the people who are asking that certain measures be passed, we should see to it that measures are presented that we are willing to indorse heartily, and not wait for measures to be presented that demand our earnest opposition.

The question of "gas commissions" has been investigated by this Association, and a most valuable report was presented by a majority of the committee to whom the task was assigned, and I would recommend that each member interested in this matter peruse that report.

To accomplish what we may desire in the lines of gas commissions in our respective States, it is necessary that a State organization be perfected, composed of the gas light companies of the State. Very little can be accomplished by an association composed of individuals who have not been delegated the power to bind, by their acts and utterances, the corporations they are supposed to represent.

Papers.—The proper committee have selected a number of subjects

to be presented here by writers who will treat the matters fully and clearly from their points of view; and while we may not agree with them upon certain points, it is hoped that the discussion thereon may be thorough and complete, and result in bringing out the full facts on both sides of all the questions presented for your consideration.

"Relative Value of Gaseous Fuels" is the subject of a paper to be read by Mr. B. E. Chollar, of Topeka, Kansas. The subject is a live one, full of interest to every modern and progressive gas light company, and to gas engineers generally. It is, comparatively speaking, only a few years ago when the use of gas for cooking and heating purposes was of most rare occurrence. To-day it is an important factor in our total send-out of gas—more of an item than ever before in our history; and within a reasonable time, if properly presented, will not only be a feature of our business, but will prove to be the source of our greatest revenue, particularly during the summer months. A number of experiments are about to be made to demonstrate the feasibility of a "distinctive" fuel gas for fuel and light purposes—"fuel" as the first and principal business, and the subject of "light" as a sort of side issue. While we as gas company representatives feel a lively interest in all these experiments, our principal business here to-day is to learn how we can turn to best account the gas plant and business that we now possess.

Mr. Ed. G. Cowdery, of Milwaukee, Wis., in his paper on "Mixed Gases," will in effect give us the results of some practical experiments with fuel gas. This cannot help but prove interesting and profitable.

Mr. James Somerville, of Indianapolis, Ind., will present us a paper showing the effect of the presence of natural gas as a competitor of manufactured gas. While this subject may not apply to a large percentage of the gas companies represented here to-day, it is of great interest to quite a number of the members, and I trust that in addition to the valuable information we may receive from the paper itself, that the whole subject may be ventilated through the inquiries and replies provoked by the discussion thereon.

Mr. George G. Ramsdell, of Vincennes, Ind., will present a paper in the form of "An Argument in Favor of the Adoption of a Uniform System of Estimating the Cost of Gas in the Holder." This subject, to my mind, is a very important one indeed. Scarcely any two companies operating to-day employ the same method of keeping accounts, and it is thereby impossible for us to obtain a comparison with our neighboring company, either as to the actual cost of gas or quantity of materials used per 1,000 cubic feet, etc., etc. The matter of data upon all details pertaining to the manufacture and supply of gas is growing more important each year; but the argument I leave in the hands of Mr. Ramsdell.

Mr. Allen R. Foote's paper entitled "The By-Products of Experience" offers some new thoughts upon the value of data. Its application to the gas industry is particularly striking.

The subject of data brings us to another important question. This is what is known as "Census Year," and, for the first time, the industries directly pertaining to manufactured gas will be represented—separately and distinctly—in the industrial statistics to be gathered and published by the government of the United States. A decade ago an attempt to collect statistics was made, but the early death of the gentleman placed in charge of the work left the work unfinished. This was a misfortune felt less then than now, as at that time the gas fraternity had not yet been thoroughly awakened to the desirability of letting its light shine, in all sense of the term, before men, and the failure in the record was counted as of but little consequence. To-day, we appreciate how valuable these figures of ten years ago would be, compared with those of the present, for the purpose of showing the growth of the industries we represent. We certainly want to know just where we stand to-day, and our successors in the business in the year 1900 will want to know just what progress has been made; and in order to determine this, the facts of the present time must be on record as a basis of comparison.

The opportunity of 1880 was unfortunately lost; that of 1890 we have yet before us. I would recommend to all an earnest endeavor to furnish information asked for by the governmental officials, as fully as possible, even though to do this may require some little time and patience. It is to our interest, directly and indirectly, that the data be collected and presented in as complete and digestible shape as possible.

Especially must this be clear when we consider that the electrical industries will be fully represented in all branches and departments in the Census totals, and that no stone will be left unturned to render such statistical representation complete. To this end, leading representatives of these industries are asking Congress to set aside a large sum, in addition to the regular Census appropriation, for the further investigation of electrical energy in all particulars in which it enters the arts, sciences or general industries of the country.

With such an example before us, it is expressly necessary that we

shall not hold back any information sought, but rather aid, in all ways possible, those who have been selected to gather together the figures that must tell the story of our status as a manufacturing industry.

Mr. Geo. T. Thompson, of St. Louis, Mo., will give us his "Impressions of British Gas Works." We have several times been favored with some few remarks made by gentlemen from abroad traveling in our country, who have given us the impression created upon their minds after examining some of our gas works and holding conversation with some of the American gas managers; but in this instance we are to be treated to the impressions created upon an American mind after examining British gas works. The paper cannot but prove interesting to each member, and without doubt many points will be presented that can be turned to profit in our practice, particularly in the case of a strictly coal gas works.

The subject of "Wrought Iron, Cast Iron or Steel—which is the Best Material for Street Mains?" will be presented by Mr. Eugene Priutz, of Zanesville, O. This is a subject that many of our gas light companies are much interested in at the present time. It is to be hoped that during the discussion each member will contribute his mite to the fund of information desired upon the question.

Mr. Fred. Egner, of St. Louis, Mo., will present his views "On the Abuse of the Patent System, as bearing on the Gas Interests, with a Remedy."

"What Policy should the Gas Interests Adopt in Connection with the World's Fair" is the subject of a paper to be presented by Mr. Walton Clark, of Philadelphia, Pa. Upon this subject I desire to call your attention to what has been done during the past year by the Western Gas Association, and also the American Gas Light Association, in the premises.

At the Western Gas Association meeting, held at Cincinnati last year, your President, Mr. Geo. G. Ramsdell, in his address suggested that the gas industry be properly represented at the World's Fair, and the committee upon the President's Address reported upon this subject in the following language:

"We also suggest that this Association endorse the idea of properly observing, by an exhibition of appliances and otherwise, the centennial anniversary of the introduction of gas lighting, and that we respectfully suggest to the American Association that it take the general direction of affairs looking to that end." This report was adopted by the Association.

At the Baltimore meeting of the American Gas Light Association, last October, provision was made for the appointment of a committee to act officially on behalf of the American Gas Light Association to consider the question of proper co-operation between the several gas light Associations of America, and take such action and make such recommendations as may by them be deemed advisable.

I, therefore, recommend the appointment of a proper committee from this Association, to meet and co-operate with the committee of the American Association, to consider and take action for the proper representation of the gas industry at the coming International Exhibition.

And, also, that the committee be instructed to complete arrangements, if possible, for a union meeting of all the Gas Light Associations of America, to be held in the city of Chicago during the year, as suggested by the invitation extended by Hon. DeWitt C. Creiger, Mayor of Chicago, on behalf of the citizens of that city, and also a like invitation extended, signed by the Committee on Gas Industries for the World's Exposition, 1892, at Chicago, as presented and read at the last meeting of the American Gas Light Association, at Baltimore, Md., October 16th, 1889.

Obituary.—Death has demanded, during the year, more than a liberal harvest from our ranks. Five valuable and much respected members of this Association, who were on earth at the time of our last meeting, have passed beyond mortal vision, leaving to us the lesson of their virtues, and admonishing those who remain that death ever awaits upon the steps of life, and that with the grave there can be no controversy.

Death ever seeks a shining mark, and no words from me can add to the luster of the names borne by these gentlemen in life. Their qualities and achievements are too well known to require any words of mine to proclaim who and what they were.

The death of these gentlemen, in conformity with our custom, demands that suitable memorial resolutions be prepared and reported to this convention.

Conclusion.—In conclusion, gentlemen, the officers selected and assigned the duty of making the necessary preparations for the thirteenth annual meeting of this Association have put forth their best efforts to render the meeting a complete success, as far as it laid in their power so to do. To what further degree success is attained, is a matter that rests entirely with the effort put forth by each individual present,

I trust that each individual will appreciate the importance of his presence at the meetings during the convention, and will cheerfully contribute toward the fund of information demanded, remembering that, no matter how great or small his contribution to that fund may be, it cannot possibly reduce the fund that he may now possess, but possibly might prove to be of material benefit to his hearers.

Mr. Ramsdell—I know we have all listened with pleasure to the able address which has just been read, and as there are some points in it which need to be brought more particularly before the Association, I move a committee of three be appointed by the Chair to consider the address, and to report to this meeting of the Association.

The motion was agreed to, and the President appointed as the Committee Messrs. G. G. Ramsdell, B. E. Chollar and A. E. Forstall.

POSTPONING THE ELECTION OF NEW MEMBERS.

The President—The next business before the meeting is the receiving of applications for membership, and balloting thereon.

Mr. Jenkins—Quite a number of applications came to hand this morning, and as the committee have not had time to act upon all of them, I would suggest the matter be deferred until the afternoon session, when the committee can report at one time upon all the applications received.

The President—There being no objection, it is so ordered. The next business will be the reading of the reports of the standing committees.

The Secretary read the following

REPORT OF BOARD OF DIRECTORS.

ST. LOUIS, MO., May 20, 1890.

A regular annual meeting of the Board of Directors of the Western Gas Association was held at the Lindell Hotel, at 10 o'clock this morning, with the following members present:

Chas. R. Faben, Jr., E. H. Jenkins, C. W. Butterworth, J. S. Ambrose, B. E. Chollar, J. B. Howard, Z. T. F. Runner, E. G. Cowdery, J. W. Dunbar, and A. W. Littleton.

Absent, Frederic Egner and John Gimper.

President Chas. R. Faben, Jr., occupied the chair. On motion of Mr. Jenkins it was carried that the hours of 10 A.M. and 2 P.M. be recommended to the Association for adoption for the convening of the business sessions of the Association.

In the absence of Messrs. Emerson McMillin and A. E. Boardman, members of the Committee on Obituary Resolutions, it was moved by Mr. Runner and carried that Messrs. James Somerville and John McIlhenny be appointed in their stead.

On motion of Mr. Howard the following papers were favorably acted upon, with a recommendation that they be read before the Association:

"The Relative Value of Gaseous Fuels," by B. E. Chollar.

"The World's Fair and the Gas Associations," by Walton Clark.

"Bye-Products of Experience," by Allen R. Foote.

"Report of Committee on Gas Companies' Accounts," by George G. Ramsdell.

"Mixed Gases," by E. G. Cowdery.

"Effect of Natural Gas Competition," by Jas. Somerville.

"Wrought Iron, Cast Iron or Steel—which is the Best for Street Mains?" by Eugene Printz.

"Impressions of British Gas Works," by Geo. T. Thompson.

"On the Abuse of the Patent System as Bearing on the Gas Industry: with a Remedy," by Frederic Egner.

The Chair announced the appointment of the following committees:
On Applications for Membership.—E. H. Jenkins, C. W. Butterworth, and J. W. Dunbar.

On Examination of the Books and Accounts of the Secretary and Treasurer.—G. G. Ramsdell, J. S. Ambrose and E. G. Cowdery.

Mr. C. W. Butterworth moved that the Board here adjourn, subject to the call of the President, which was carried.

A. W. LITTLETON, Secretary.

On motion of Mr. Jenkins the report was received and its recommendations adopted.

APPOINTMENT OF SPECIAL COMMITTEES.

The President—With your permission I will appoint the special committees.

On Receiving and Introducing Visitors.—Messrs. J. S. Ambrose, L. K. Scofield and B. W. Perkins.

On Nomination of Officers.—Messrs. E. H. Jenkins, R. H. Canby, J. T. Lynn, Henry T. Pratt and J. D. Thompson.

On Place of Meeting.—Messrs. E. G. Cowdery, Eugene Printz and I. C. Baxter.

On Resolutions.—Messrs. Walton Clark, G. A. Hyde, Jr., and Edward Lindsley.

If the committee on reception of visitors is ready to report, the Chair would like to have it presented now.

Mr. Ambrose—Having not had opportunity to consult with my associates on the committee I will take it upon myself, in order that business may be facilitated, to introduce the visitors who are with us to day, and then give way and let them make the speeches. We have with us this morning, Mr. A. B. Slater, of Providence, R. I., an ex-President of the American Association; Mr. C. J. R. Humphreys, of Lawrence, Mass., the Secretary of the American Association; Mr. John P. Harbison, of Hartford, Conn. and Mr. R. B. Taber, of New Bedford, Mass., both ex-Presidents of the New England Association; Mr. H. B. Leach, of Taunton Mass., Mr. Jos. R. Thomas, of New York, and many others whom we are glad to welcome to our convention as visitors and guests. Times have somewhat changed. According to the old custom and teachings of our fathers, we were told that in order to find the true light we should look East; but now we find, instead of that, a body of representative gentlemen coming West to associate with a large body of gentlemen representing the true light; and the gentlemen are in search of light. And, further, these gentlemen are a little different to some of our ancient fathers, in that, whereas they traveled without the hope of fee or reward, these gentlemen have come out here, perhaps without hope of fee, but nevertheless expecting large rewards. I bespeak for these gentlemen kind treatment. I hope they will be allowed to roam through the forests of this Western City unmolested; that they will be cared for properly, and that, if necessary, a committee be appointed to see that their scalps shall not be taken off by the Indians who roam through these western countries. I will leave it to the President to see that they are properly cared for and protected.

The President—Gentlemen; I welcome you to this meeting of our Association, and hope you will feel entirely at home with us. I can guarantee police protection to you during your stay in St. Louis. One special committee under instructions to report at this meeting has, through its Chairman, asked for further time, stating that the committee will be prepared to report to-morrow. I refer to the committee appointed on the subject of the paper, read by Mr. Gimper last year, on "The Education of the Gas Engineer." Mr. Gimper will report on that to-morrow.

MR. GIMPER SURPRISES THE CHAIR.

Mr. Gimper—I have another report to make and it is this: One year ago the Association was called to order with a policeman's club. As a member of the Association I felt very much mortified that a body of such peaceable and intelligent gentlemen should be governed with such a weapon, and I made up my mind then and there that at its next meeting I would provide the Association with a suitable gavel. For this purpose I have chosen the upper part of the center-seal as the head of the gavel; for, as the gas flows from the center-seal, first through the purifier, so during your deliberations it passes to and from the presiding officer. This gavel, therefore, becomes an instrument of strength in your hands; and as a member of this Association I take pleasure in presenting it to you, and through you to the Association for future use. (Applause.)

The President—On behalf of the Association, Mr. Gimper, I accept from you this gavel. I can hardly add anything to what you have said of the necessity of an instrument of that kind in the hands of the President of the Association. While the gavel may prove a great and effective instrument in the hands of some of the presiding officers, yet I am afraid that your present officer is hardly able to wield it with that strength. But I shall use it with pleasure, and hand it to my successor; and I trust that its use in connection with this body will prove satisfactory.

On motion of Mr. J. B. Howard a vote of thanks was tendered to Mr. Gimper for his very appropriate present.

The President—I have omitted to name a committee on suitable memorial resolutions. I supposed that the Board of Directors would name the full committee, but as they did not do so I will appoint as a Committee on Obituary Resolutions, Messrs. J. B. Howard, James Somerville and John McIlhenny.

REPORT OF TREASURER.

Secretary and Treasurer Littleton presented his annual report, of which the following is a summary:

Receipts.

To balance, cash on hand, May 1, 1889.....	\$529.95
To membership fees.....	175.00
To annual dues.....	533.00
To badges.....	321.75

\$1,559.70

Disbursements.

By Secretary's salary.....	400.00
By badges (200).....	675.00
By sundry bills as per accompanying vouchers.....	380.39
By balance, cash on hand May 1, 1890.....	104.31
	\$1,559.70

Mr. Ambrose, from the Finance Committee, reported that they had examined the Treasurer's accounts and found the same to be correct. On motion the report was received and filed.

Mr. Ambrose also stated that the Secretary had on hand nearly 100 badges which he hoped would be taken by members during the session, as the sale of those badges would increase the amount of money in the treasury by some \$350.

READING THE PAPERS.

Mr. Frederic Egner, of St. Louis, then read his paper

ON THE ABUSE OF THE PATENT SYSTEM AS BEARING ON THE GAS INDUSTRY: WITH A REMEDY.

Prologue.—After having written the paper about to be read, a letter and a copy of the last annual report to Congress, of the Hon. C. E. Mitchell, Commissioner of Patents, were forwarded to me through the courtesy of that gentleman. With your kind indulgence the following interesting extracts from the report mentioned will be given as a fitting prologue to my paper.

"In entering upon the discharge of the duties thus imposed (writes Mr. Mitchell) I am reminded that this is the one-hundredth year of the American patent system. It was on the 8th day of January, 1790, that President Washington, in an address constituting his first annual message, said to the assembled Houses of Congress: 'I cannot forbear intimating to you the expediency of giving effectual encouragement as well to the introduction of new and useful inventions from abroad as to the exertions of skill and genius in producing them at home.' Both Houses of Congress sent cordial response to the President's address, and promised, especially to his suggestions for the encouragement of science and the arts, 'such early attention as their respective importance requires.' A bill was soon matured, which, after amendment in the Senate, became, on the 10th of April, 1790, by the signature of President Washington, the first American law authorizing the granting of patents for mechanical inventions. Mr. Mitchell proceeds to state that during the century 437,000 patents have been issued. During the first 50 years only 12,421 were granted, while in the single year ending January 1st, 1890, nearly 25,000 patents were allowed. The first patent issued for a 'gas apparatus' was to David Melville, of Newport, Rhode Island, March 18, 1813, for an 'Apparatus for Separating the Hydrogeneous Gas or Inflammable Air from the Carbon and Less Volatile Ingredients of Pit Coal.' Since then 2,550 patents have been issued for processes, apparatus or improvements connected with the manufacture of gas."

And now I will read my ideas on—

The Abuse of the Patent System.—The subject of this paper is one which, in the opinion of the writer, deserves more than a passing thought, not only of those who are directly engaged in the manufacture and sale of gas, but of those who purchase the product, and those also who by the people are chosen to make their laws. If any attempt was made before this time to attract the attention of professional gas men, and that of others as well, to the abuse—and its baneful effects upon all concerned—of the patent system, with particular reference to the gas industry, the writer is not now aware of it. Should this paper be the means of arousing some of those affected to seriously consider the matter, its object will have been accomplished. And if such action should cause proper steps to be taken to check or eradicate the abuse of this—one of the most valuable systems for the advancement of civilization and the amelioration of the condition of the human race, which the patent system certainly is—then the author would feel happy indeed in the thought that he had helped to do something which was worth the doing.

To make sure not to be misunderstood, a few general remarks about the patent system of our country as a whole will not be out of place here. That much good has been accomplished by stimulating the inventive genius of man may be seen by anyone who will look about, compare the state of civilized nations with that of the half-civilized or barbarian people of the world, and reflect upon the cause thereof. Usually the whole credit for these improved conditions is given to religion and education, but quite unjustly so. Because, although religion and education have done—and will continue, we hope, to do—their useful work, they have not helped man to the ease and comfort now enjoyed by the large majority of the people. The reader of history knows that religious zeal was at no time as powerful as in the so-called dark

and middle ages; and even in the records of the morning of our own country we can read of horrible atrocities having been committed in the name of piety and religion. So, you see, we had plenty of religion then and education, too—for the famous seats of learning, Oxford, Heidelberg and many others are centuries old; and even beyond these we can refer back to the ancient Roman, Greek, Arabic and other systems of education, which furnish us with the substance of the higher text-books in our own schools to this day. In those early days of religion and limited education only, inventors were called sorcerers, and were treated accordingly, as we are informed by historians. The masses were not educated, which was one of the chief difficulties in the way of the improvement of man. But gradually the light came. Not to waste your time in speaking of matters with which you are all familiar, it may yet be permissible to mention a few examples of what invention has done for the world, and the most of which was done *after* the introduction of the patent system, though some few of the most useful inventions were made before that time. But the patent system stimulated invention to noble exertions. First of all the useful inventions that occur to me now is the printing press or art of printing, which was the means of spreading knowledge where it had not reached before. Later on the newspaper followed. Too much can scarcely be said in praise of *the newspaper*—the educator and molder of the opinions of the masses.

Though the power of the press is sometimes (like the patent system) prostituted to selfish ends, it has, on the whole, done more good in the cause of humanity than sword or gun, warriors or orators; and I cannot conceive of a more noble, useful or honorable calling than that of the newspaper man, from the conscientious reporter up to the able editor and manager; and we may indeed exclaim with Axel Oxenstierna, "The pen is mightier than the sword." But it was the inventive genius of man who gave us the press and movable type, the steam engine, steamships, and railroads—the latter one of the greatest of all civilizers and beneficial institutions of the world, although it, too, like all good gifts of the Almighty, has been more or less abused in some notable instances to further the aims of avarice and fraud. Still, on the whole, railroads have been the means of developing this great North American continent, opening homes for millions of people, all of which would not have been possible in the same time but for the railroads, which therefore deserve praise and not the more frequent abuse which they get—let me say it with sorrow—like the gas industry, nearly always unjustly so—from our useful and esteemed friend, the daily press. It is not in the province of a paper like this to even mention all the great inventions, or to tell you what you all are acquainted with, as previously remarked.

And the subject of this paper is the *abuse* of the patent system, not the *praise of invention*. Let us get down to our subject, only mentioning in passing that the introduction of gas was acknowledged to be one of the most useful of all inventions, and it was admitted to have done much in the cause of morality, the safety of persons and property, and the comfort of man, in its early days; and we all strive to improve that article now—that is one of the objects of this meeting. And it has not been, nor is it likely to be, permanently displaced by electricity; and fuel gas, or at any rate gaseous fuel, is one of the sure things for all to enjoy very soon.

Now let us consider the *abuse of the system*, which my preceding words show to be fully appreciated by the author and not at all condemned. The patent system is abused by two classes of people, the self-deceived and the deceivers, for gain, and what the law makers and the community in general, as well as the gas maker, have to do with it; how they are all affected can best be told by relating a few examples which have come under my observation.

Some years ago certain parties organized what they were pleased to style "A Gas Economizer Company." Their stock in trade consisted of a working model of a carburetor, many forms of which you know all about. This carburetor was, of course, protected by letters patent, which gave the thing undeserved prestige in the first place. The Company was incorporated and had offices at East St. Louis, in Illinois, where such things can be done very cheaply. But the incorporators aimed at the bank account of any simple St. Louisians whom they might be able to catch in their net, and they succeeded very well. Take a tight paint keg—or even a good nail keg would answer—fill it with sawdust soaked in gasoline, make a connection in the bottom of said keg with the gas supply pipe of a house, and another connection at the top with the pipe through which the gas must pass to burners, bore a second hole in the top of the keg, which hole may be closed by means of a cork when not to be used for the purpose of pouring a fresh supply of gasoline over the sawdust within, and you will have a first-class carburetor. Now, if a branch pipe, with a burner attached, was connected with the inlet of this carburetor and a like arrangement made at the outlet of same, and

the gas lighted before and after passing through the material in this improvised gas machine, almost anybody—except a gas man of course—would be struck with the great improvement in the appearance of the light of the gas. All this is really too elementary to mention before this Association, and my only excuse for doing so is to illustrate, by relating actual occurrences of recent dates, the simple means often used by these abusers of a noble system; by its very aid, to defraud their fellow man and make no end of trouble for gas companies wherever they may strike them. The "Gas Economizer Company" disappeared from public view very quietly, and the victims did not boast of their losses as they had previously boasted of what they would do with the gas company. Another company soon after opened rooms in the business center of this city. This company also had a patent and a working model apparatus made of glass, and one much larger made of wood and copper. These people made gas from water, zinc, a little acid and *oyster shells*. The latter were possibly employed to add a little mystery to the process and make it commensurably more attractive to those who had the dollars to invest. The writer of this paper was consulted about the matter by two wealthy gentlemen, who had been partly convinced of this great discovery by means of the aforesaid glass model—for behold "there they could see with their own eyes, don't you know," the *modus operandi*, and who could doubt after that? On having the matter explained to them they withdrew, half angry at the consulting engineer, who no doubt saved them thousands of dollars, where they had up to that time only expended a few hundred, for destroying their "Castles in Spain," though it was done at their request. The process consisted simply of decomposing water by means of acid and zinc, carbureting the liberated hydrogen by means of gasoline, and the burning for exhibition of the resultant mixture, which of course gave a brilliant light. This method of producing gas is as old as gas making itself nearly, and is not used for the self evident reason that it is not financially practical; in other words, it don't pay by great odds. Without a patent, the schemers who peddled this "great invention" could scarcely have been able to obtain the support of any one wishing to invest money; for the common sense reason, which is or ought to be understood by everybody, that gas companies are not likely to employ any but the best practical processes to manufacture illuminating gas—a matter well worth thinking upon by people sufficiently interested in gas to use it, not to speak of would-be-investors and legislators. *That truth* seems to be forgotten in all such cases as those referred to, and yet we are bound to see how, with a recent patent for a worthless invention, such as described, even men endowed with good common sense, but who are not educated gas men, could be deceived. Such practices are simply swindles and ought to be dealt with according to laws not yet made to prevent them. The Massachusetts Gas Commission, however, is so far the only lawful safe-guard for consumers and producers of gas alike, and ought to be imitated by other States, and could not fail of beneficial results, more especially if the officials selected were of the stamp, ability and character of the gentlemen who constitute the Gas and Electric Light Commission of the Commonwealth of Massachusetts.

We next may consider those who, really skilled to a degree in the art of gas making, and supplied with some money, have adapted some well known principles or some other man's ideas in what they are pleased to call a process and apparatus of their own. Some of these people are honest, except as to stealing other men's brains, which they consider no crime, and some are everything but what they ought to be. These are the fellows who, after selecting a, to them, suitable locality, quietly enter business by at first showing to a few wealthy residents, who are known to have a grudge against the local gas company, their wonderful apparatus. Disregarding the cost of distribution of gas, the miles upon miles of mains, service pipes and meters, costing according to location from the simple tens of thousands to the millions of dollars, and gradually but surely growing worthless, until they must all be replaced; disregarding all this, the necessary attendance, unavoidable bad debts and dozens of items, all of which you fully understand, these men, who would be worthy descendants of the ancient pirates, without their courage, perhaps, simply compare the *manufacturing cost* of gas by their apparatus with the *selling* prices of the gas vendd by the local gas company; and thus they soon obtain interested listeners and sometimes strong partners.

Next, the law makers of the town, city or State are similarly approached and convinced in the same way of the alleged shameful practices of the gas company. The legislators, unless cool, clear headed men, often feel that their constituencies could not help but gratefully appreciate any efforts to have them more justly—as they imagine—treated by the gas company; and so it happens that sometimes braving obloquy and detraction by the opposition newspaper, or even friends, they give

charters right and left for gas undertakings opposed to the old one, and more than that, use all their power to enact laws absolutely ruinous to the very foundation of the social fabric, were said laws permitted to stand by the courts of the land; as was the case not long ago in this very city, when the local "Solons" passed a law that after April 1st the Gas Company *must* sell gas at the rate of 90 cents for 1,000 cubic feet of 18-candle gas. Not one of the influential newspapers of the city had a word to say against the act; never once apparently considering that if it is lawful to regulate the price of gas sold by a private corporation, it is also lawful to regulate the price of bread, clothing, everything, not forgetting wages, in the same way. Did any one reflect upon where such a course would lead to? If so, no matter, the blow was at the Gas Company, and that excuse seems to make any iniquity right in the eyes of the people and the daily press. But if that sort of thing is not stopped, that act is only the entering wedge of a powerful social revolution, and the day of reckoning will surely come for those who sat quietly by and allowed a great wrong to be done, because it was done, forsooth, to the Gas Company.

Do I appear to be wandering from my subject, "The Abuse of the Patent System?" No, I think not; for as great oaks from little acorns grow, so it is in this matter, because without abusing the patent system, the things, of which a few examples have been related, could not have happened in the first place. My paper is already too long, I fear; but it could not be shorter and begin to show the danger of the abuse of the patent system with especial reference to the gas industry. But it is contrary to my ideas of propriety to speak of an abuse without also to at least suggest a remedy. Meetings like those of this and kindred Associations do something toward checking the evil. Other means have been proposed but failed, and there is in my opinion at present not one which would meet the emergency as the measure so successfully established and working in the old and cultured State of Massachusetts—I mean the Gas and Electric Light Commission previously referred to.

If the members of this Association could organize State committees for the purpose of presenting this matter of gas commissions to their State Legislatures it would possibly do some good, and could do no harm. This matter of the abuse of the patent system is growing in importance year by year, and there is scarcely a gas company or a community which has not had to suffer from it financially in some way. The system and the U. S. Patent Office are not to blame. The system, as was shown in the beginning, has done much good to the country and the people. The Patent Office officials must be, and are known to be, able and conscientious persons, and the only trouble with the Patent Office is that the force employed is not half enough to properly do the immense amount of business which is so rapidly accumulating there; that some of the branches of it are hopelessly behind, to the injury of the office and the people, especially inventors. In conclusion, let me repeat that the abuse of the patent system, with special reference to the gas industry, can, in the writer's opinion, be met best in the interest of the people who buy and the people who sell gas by a measure like the tried and approved Massachusetts Gas Commission.

Discussion.

The President—You have heard a most excellent paper read by Mr. Egner, and it contains a number of suggestions which have not appeared in just that form before. As the subject is one to which Mr. Egner has given a great deal of thought I know he will be pleased to answer any questions. A great many of us have in a measure participated in the profits of patents, and some of us have had a share in the losses which have been entailed by reason of having patented processes forced upon us. The paper is now before you for your discussion.

Mr. Ambrose—It strikes me this matter is of too much importance to gas engineers and to the gas industry to let it pass by without comment. As has been stated by Mr. Egner, we see the result in Massachusetts of the adoption of the plan which he suggests; and I believe if proper steps were taken we could get an act of the same kind enacted in the State of Missouri. If we could have a proper committee to go before the Legislature and properly present the subject for their consideration, I am of the opinion that something could be accomplished; but even if nothing of that kind resulted from it it could do us no harm. The gas interests of this State have been pilloried in about every possible manner, and every company in the State has had to take its abuse for declaring large dividends, when, as matter of fact, very few of us see anything of them. It is a good deal like what the old gentleman said who had been induced to put a little money in a bank. He had never investigated a matter of this kind, and so when they brought him a paper he looked it over and said, "Well, I don't know anything about that, but I would like to see

my dividings." A good many of us are like him. We do not care what they say so much if we can only see the proper "dividings." While we have received the abuse, we have not received the dividends. I think this matter ought to be referred to a committee in order that it may be thoroughly investigated, and, if thought best, a committee appointed from this Western Association, not only to go before the Legislature of this State, but of all the States that desire it. This is too important a matter to be passed over lightly.

Mr. Scofield—I hope someone more able than myself will speak upon this subject; but I have thought a great deal of the matter, and it certainly is a topic of much importance to this Association. As yet the State of Massachusetts is the only State that has provided a way and means by which these interests may be protected and directed. Coming as I do from Kansas, where there are but few gas companies, we have been slow to take any action upon this subject: but I feel that this Western Association in its strength and in its power ought to take the matter up. I agree with Mr. Ambrose that a committee ought to be appointed—a committee to cover not only the State of Missouri but the rest of our territory—so as to bring these matters in some form before our Legislatures, and if it be thought best some law can be introduced which shall bring this thing to a point; which shall bring to bear upon our industry such measures as shall protect the industries that have been legitimately established, and rid us of the opposition of those who, as our friend Egner says in his paper, foist patent schemes upon the people whereby they are induced to invest their capital in things which they know nothing about. I am fully aware that our gas fraternity, as a business people, when they sit down to figure, to contemplate, and to consider what their real interests are, know just how to do it; but the object is to get a commission which shall bring to bear an influence to protect these industries; and such protection would not only benefit the gas fraternity, but it would benefit the consumer as well. We have felt that in the State of Kansas. You have felt that here in Missouri. When one reads day after day, as I have for the past four or five years, of what has gone on and of what is going on in the city of St. Louis, my blood boils in my veins, although I have had no interest in this city except my general interest in the welfare of the whole gas fraternity. When the people in St. Louis through their lawmakers attempt to pass laws to destroy your interests, you who are selling gas at \$1.15 per thousand on a contract made four or five years ago by which it is your privilege to take \$1.25, by saying to you that you shall only take 90 cents per thousand—well, I am afraid that I will say too much. There is not only this practice of browbeating, but there are other schemes and schemers. I do not want to call names; you know who I mean, and I would just as soon they would know. Now, the only way to avoid this, the only way to get around it, so as to protect the gas industries and the gas interests legitimately, in my opinion, is to bring a power upon our Legislatures and have laws enacted by which our interests can be protected. We do not want all the earth. We are willing to take fair and reasonable dividends on the capital invested; and the only way that we can do it, in my opinion, is by means of these gas commissions. I do not know that I should fully uphold this commission business, but I say that in order to protect our interests, and the interests of the public, we have got to adopt some such measure.

Mr. Watts—I would like to ask Mr. Egner if he has matured any plan to accomplish the organization of commissions in different States, or whether he expects that the gas companies can do anything through their State Associations.

Mr. Egner—I have not matured any plan. I thought that our gas Associations should be something more than mere social gatherings for the reading of papers on subjects with which we are sometimes already pretty well informed. We are not here merely to have a good time. We ought to do something. Plans have been formulated before this. I believe this very thing has been brought before the Association before, and I was in hopes that the paper would bring on such a discussion as would induce the Western Association to take some steps forward in the matter. The only plan that I had thought of was that the State Associations would appoint committees, or that the members of this Association in the different States would form State committees who would take this matter up, and not let it rest until there was something accomplished, because there is no such word as fail if you are determined, and act understandingly and together in the matter. I thought that a great Association like this, which would perhaps have the sympathy of the American Gas Light Association in this movement, ought to be able to accomplish much. We are all working for the same end—for the protection of our stockholders and ourselves; and we might confidently rely upon having the aid and advice of other Associations. I thought that I would introduce the subject, and then leave it in the hands of the Association.

Mr. Lansden—The American Association, as many of you are doubtless aware, put itself on record a few years ago as being in favor of Gas Commissions. I think this Western Association can do little or nothing acting as an Association. Each State has to work out its own salvation. The American Association, as I have said, expressed themselves in favor of Gas Commissions, at their meeting in Philadelphia, four years ago. I do not see that there is any way that this Association, composed of gentlemen from all the States, west and south, as an Association, can do anything, even with the Legislatures.

Mr. J. B. Howard—I understood that this paper of Mr. Egner's was on the abuse of the patent system. Now I would like to know what an Association, or what any commission, can do towards stopping the inventive genius of the American people. If you appoint a commission here to look after patents, and to determine whether they are worthless or not, I think you will have to appoint a very strong committee, and have a very large organization. I cannot conceive how this Association can touch upon the question at all favorably, or give the matter any attention that would accomplish anything worth having. As I said before, the inventive genius is here. I remember some twenty years ago a man came to our works with a patent that was going to save 10 per cent. of the gas. He was an elegant looking gentleman, 60 years of age, highly polished, a most interesting talker, well dressed, and altogether presenting such an appearance that you would not think for a moment he was other than an honest man. And I would not have doubted it had he not made a remark that, as a gas man, convinced me he did not really understand what he was talking about. As matter of fact he was a fraud from the start. Perhaps some of you are acquainted with, or have met just such men. I think he succeeded in selling his patent right in some cities; but the power of the press entered into the situation, and no doubt prevented quite a number from paying out what they would have done had they not read an article in the AMERICAN GAS LIGHT JOURNAL exposing the fraud. He went on to state that the article he had for sale would so improve lime purification as to save 10 per cent. in the cost of it, and it would also stop all the "sputtering" of the gas while burning. That remark gave him away.

Mr. Ambrose—Did he have anything that would stop the sputtering of members?

Mr. J. B. Howard—I asked him particularly as to that point of sputtering. He got confused and said, "Well, if you don't see the situation properly I will see the directors and try to get them to understand it." I told him I would be very glad to have him do so; that I had a wagon outside and would take him right up and introduce him to the President of the Company. He did not go, however, and I heard nothing more of him. Now, as to getting rid of the patents. You cannot stop them. They will be constantly cropping up. A man will think that he has struck a good thing, will patent it, and will eventually find out his mistake. Some years ago at Fort Wayne a man came to the gas works to get advice with regard to a patent fluid that was being hawked around for sale—a non-explosive fluid. Mr. Spencer asked him what he wanted to pay money for anything like that, and added, "I will give you a receipt which you can get patented, and then it will not cost you near as much money." The inquirer replied, "I don't know but what I will accept your proposition." "Very well," said Spencer, "I will give it to you now. Buy a barrel of naphtha, take out the bung, blow your breath in it, and you will have just as good a non-explosive fluid as this." Therefore, I cannot see how this Association really can prevent the multiplication of patents.

Mr. Egner—I think Mr. Howard has got hold of the idea wrong. Understanding it as he does I would be of the same opinion as he is; but as I understand it, in Massachusetts if one of these kind of people that I have described comes into town and wants to get up a scheme for a new gas company it has to be referred to that Commission, who look into the situation. If the thing does not look feasible to them they sit down upon it. I understand that all such things are referred to the Gas Commission. Now, a party will come here, get capital together, start an opposition company anyhow, and the people who put their money in it, of course, do not want to lose it. One company started in as a light, heat and power company, or as a fuel gas company, and when they found that the fuel gas would not work they made carbureted hydrogen gas. This practice has cost some people hundreds of thousands of dollars, and it has also cost the legitimate gas companies hundreds of thousands of dollars. By means of a Commission like the Massachusetts one that would have been prevented. If a man went to them with scheme for making gas from oyster shells they would look into it to see if gas could be made in that way, and if they found that it could, they would give the permission; if not, it would not be given. What this Association has to do is just this: If the members of the different States

would take hold of the matter, and as such would try individually to do all that they could to influence the members, or to set them in the right direction by telling the truth about the matter, and by getting proper memorials before the Legislatures, proper laws might be passed, whereupon, instead of having to deal with a lot of corner grocery men, or with men who do not know anything—some of whom cannot even write their own names, but who are elected to the House of Delegates of the State of Missouri—we would have to deal with one commission composed of intelligent and conscientious gentlemen. That was the idea I tried to bring out in my paper; and I think it is in that line that this Association can act. If you put it off for a while longer it will be harder to do next time, and you will all be hurt worse then.

Mr. C. D. Jones—I am much interested in Mr. Egner's paper on the abuse of the patent system as bearing on the gas industry, with the remedy which the writer has suggested. In the State of Iowa, within the last four years, a law has been enacted authorizing Councils in every city of over 7,000 population to fix the price to be charged for gas. We have no Association in Iowa, and the companies are not strong enough to take hold of this matter and secure any proper action by the Legislature. It looks to me as if it was a very important matter to get gas commissions appointed, whose duties could be made large enough so that every application of the kind referred to could be turned over to the commission. I think it would be a grand thing for the protection of the gas industry in our State, and in every other State as well.

The President—If the members will indulge the Chair for a moment I would like to state what has been done by the electric light associations. They have a national association, and that association has endeavored to secure the enactment of laws that would protect the electric light industry against the raiding of prices that they have been subjected to; for they have had an experience much the same as that which gas companies have gone through. They found it was not national legislation that was required; that national organization could accomplish very little. That a national organization could gather a large volume of statistics, and get very valuable suggestions, but that for practical operation it would devolve upon State organizations. For the purpose of facilitating matters they appointed a committee on State and municipal legislation, with one member from each State. It was found after trial that one member from each State could accomplish absolutely nothing. They could get together data and statistics relating to the different States; but they found when grievances were reported that they were absolutely powerless to resist attacks or raids when made against companies in the several cities. That brought up a suggestion that State organizations be formed. It brought up the further suggestion that State organizations with individual memberships amounted to nothing; that although a hundred men could get together once or twice a year and compare notes—although it was very pleasant, and there was a large amount of sentiment about it, yet it accomplished nothing practicable. If we contribute \$5 per year each it is only \$500 in the aggregate; and \$500 will accomplish very little in the maintenance of an organization, in collecting statistics, and in formulating the measures that the gas industry would want enacted. So that it led to the formation of State associations, composed of the local central station companies. The membership of the association was made up of the companies themselves, not of the presidents, or engineers, or general managers, or treasurers; all of those members could be present at the meetings, but only one could vote in the name of the company at the meetings of the association. It was made up of company membership. Now, that body of men, having that interest, and having delegated to them the power to bind the several companies by their acts, having power to levy assessments if necessary on the companies according to their capital stock, formed a strong organization, and one that enabled them wisely to formulate and properly present acts which would be desirable. The reason that the electric people have progressed so far and so rapidly, and have come to such a firm conclusion on this matter, is because the present status of their business demanded just such an organization. They recognized the fact that as State organizations simply they would be a very weak element, but that when combined together in one general organization—as the States of the Union are in one general government—it would be a very strong power. If the gas companies of Missouri were to perfect an organization—not necessarily as an incorporated body, with power to sue and to be sued—come to some conclusion as to what they want and then proceed to get it, they would accomplish much. They do not need to meet in conventions of this kind and have their proceedings published to the world, but they might meet as directors of companies. They would want the aid and counsel of other organizations, but that might come through the national organization. I think it is right and proper that

the Western Association or the American Association should investigate the merits or demerits of questions of that kind; but for getting the thing into practical operation I think we would require State organizations.

Mr. Ramsdell—I think the difficulty with this question is that as an Association we have no power to deal with it. This ground has all been traveled over before. At our meeting in Columbus several years ago majority and minority reports were presented, covering just the ground which is brought out by the discussion at this time. The majority report recommended State organizations, with a view to having gas commissions established. The majority report was adopted by a very large majority of the Association, but the work ended there. I was one of the committee, and I know that a great deal of work was done in getting this report into such a shape as really would represent the sentiments of the members of this Association. The vote as taken preliminarily to the meeting was very largely in favor of State organizations. The trouble arose, however, from the fact that to accomplish anything at all the work must be done by the gas companies in the State itself. Take for instance the State of Missouri. If anything is to be done here the initiative would have to be taken by some few persons in the State, gathering together those representing the gas industry of the State. They can then form an organization, bind themselves to meet the actual necessary expenses, and appoint their committees for carrying forward the different matters that would naturally come under their supervision, such as legislation, the procuring of suitable data, and work of that kind. It seems to me, Mr. President, the only thing we can do here as an Association would be to endorse this suggestion and recommend that State organizations be perfected in the different States which are represented in this Association. At the same time, if we do that we are only duplicating work which has been already done, because we are already on record as favoring Gas Commissions and as favoring State organization.

Mr. Egner—As Mr. Humphreys, of Lawrence, Mass., is present, perhaps he can give us some information as to the working of the Gas Commission of that State.

The President—We shall be glad to hear from Mr. Humphreys.

Mr. Humphreys—I hardly know what relation the gas commission question has to the patent question. I do not know that I can say anything more with regard to the working of the gas commission in Massachusetts than has already been said. The gas commission was originally appointed through a resolution introduced into the Boston Board of Aldermen, by Mr. Greenough, who was at that time a member of the Board. The resolution called upon the Legislature to investigate the question of the advisability of appointing a board of gas commissioners similar to the board of railroad commissioners then in operation in that State. The matter came before a committee of the Legislature; and the representatives of the different gas companies appeared before that committee. First, the representatives of the companies of the city of Boston were heard, as they were the originators of the scheme; and the representatives of the different gas companies throughout the State, as many as wished to be heard, were heard. After considerable investigation a law authorizing the appointment of a commission was enacted, and later three gentlemen were appointed on the commission. There has been no change in the membership of the commission since they were appointed. As to the relation of the gas commission to opposition gas companies, I think it is about like this. If there is a gas company in operation in a city, and another company applies to the board of aldermen for the right to dig up the streets and lay pipe, the decision given by the board of aldermen on that application is subject to revision by the gas commissioners. There is a right of appeal from the action of the board of aldermen to the gas commissioners. The commission will hear both sides, and it remains with them to say whether the new company shall come in or not. Upon their investigation they will consider the service which the old company has been giving, and if the old company has been charging exorbitant prices, or have given poor light, I think it very likely they would grant to the new company the right to come in. On the other hand, if the old company has been doing its duty, and has been supplying the people with good light, at a reasonable price, my impression is that the gas commissioners would not allow a new company to come in.

Mr. Walton Clark—I would like to say a word about the original question, which I understand to be a proposed remedy for alleged abuses of the patent system. I cannot see what connection there is between gas commissions and the issuing of letters patent. It seems to me if there is an abuse of the patent system, that the proper remedy is in the Patent Office. Mr. Egner has cited the case of the patentee of a form of carbureter which was old; certainly the remedy in that case would have been a better examination in the Patent Office. However valuable or otherwise a gas commission might be in preventing the establishment of

opposition companies, it can hardly be expected that a gas commission would be composed entirely of gas experts who could speak advisedly as to the value of patented inventions; in fact it is undesirable that a commission should be composed of such men. I think they should not have been identified with the gas business at all previous to their appointment as commissioners. I do not see what such a commission could accomplish in the way of remedying abuses of the patent system. They could perhaps prevent the starting of an opposition company based upon new patents, but I cannot see what protection there would be to capitalists. We know that many of the patents which are issued are of no value whatever. In fact, a patent issued by the United States commands for itself very little respect. That is shown by the vast number of patent suits which are carried on in the interest of different industries. To my mind the remedy lies in the Patent Office—in securing more intelligent examiners; and I am very much in doubt whether this body, or any other gas association acting independently, can do anything in that direction. It is a question a great deal broader than the gas business. It involves the manufacturing interests of the world; and I think we cannot hope to accomplish anything by acting independently of other manufacturing interests.

On motion of Mr. Ramsdell a vote of thanks was tendered to Mr. Egner.

A recess was then taken until 2 o'clock.

(To be continued.)

The Chemistry of the Dinsmore Process.

The London *Journal* notes that at the May meeting of the London section of the Society of Chemical Industry, Mr. Watson Smith, Lecturer in Chemical Technology in the University College, London, read a paper on the above subject, of which the following is an abstract.

It will be remembered that a paper on the Dinsmore process as worked at Widnes, comparing its efficiency and cost, and the illuminating power of the gas produced, with the usual process of carbonization, was read by Mr. Isaac Carr before the Liverpool Section of the Society last year; and in it a description of its working was given. It may be well to recall the broad principle on which it is based. It may be briefly described as a method whereby the crude gas, laden with much condensable matter—potential tar—is passed through a heated chamber; and there much of the less volatile vapor is permanently gasified. As worked at Widnes, the gas from a bed of six retorts is led through one of fireclay, termed the "duct," the inlet end of which is kept at a cherry-red heat (from 1,700° to 1,800° F.), and the outlet at a dull red (from 1,200° to 1,300° F.). From this it departs by the ascension-pipe, which is water-jacketed to prevent the formation within it of coke or pitchy matter. It was neglect of this, or a similar precaution, coupled with the adoption of the plan of first making the gas in the ordinary way, and then gasifying the resulting tar, instead of subjecting the crude gas before it had deposited its tar to the gasifying process, that led to the troublesome stoppages and unsatisfactory working of the original Dinsmore process before its modification by Mr. Isaac Carr. The idea of gasifying tar after its condensation is, of course, very old, and was at first attempted in order to get rid of a noxious substance, rather than with any view of cheapening or improving the gas.

At first blush it seems strange that a gas of increased illuminating power should be obtained by any superheating process such as this is. The plan of overheating ordinary gas—thus increasing its bulk at the expense of its luminosity—is sufficiently well known to have given rise to the classical story of a port where it was, no doubt scandalously, alleged that such gas was always supplied to the street lamps in the small hours of the morning, as drunken sailors were the sole occupants of the streets. But superheating *qua* superheating is not the true cause of the improvement effected by the Dinsmore process. It is even possible that a portion of the gas suffers a change, and that for the worse—just as in ordinary superheating; but any slight loss from this source is more than counterbalanced by the gasification of the tarry vapors already alluded to.

That this is actually the case, and, further, that the action is selective, is shown by the fact that the quantity of Dinsmore tar is only about two-thirds that of the tar usually produced, and that the tar is of a totally different character from the latter. The difference consists mainly in a notable poverty in light oils and tar acids; and there seems to be little doubt that the aromatic hydrocarbons constituting the former are broken down with hydrocarbons of the olefine and acetylene series, and so appear among the permanently gaseous products as illuminants, while the phenols of the latter are reduced to their corresponding aromatic hydro-

carbons, which then suffer change in the manner indicated above. At the same time there is a noteworthy absence in the purified gas of carbon dioxide, the diluting and light-reducing power of which must not be overlooked. The interaction of the hot gaseous products in the "duct," to which these remarkable results are due, is practically uninterrupted; for the gas from each retort is only diverted to the hydraulic main during recharging.

According to the figures due to Mr. Carr, 9,800 cubic feet of 20 to 21 candle gas is produced by the Dinsmore system, as against 9,000 feet of 15 candle power ordinary gas per ton of coal carbonized. The additional candle power, in view of the increasing difficulty of obtaining cannel, is specially important. The cost of applying the extra plant to existing retorts is said to average about £6 per mouthpiece. In considering the advisability of adopting any such process, two of the chief questions are the local demand for gas of high illuminating power and the price of residuals. Where the candle power required is low and easily obtainable by ordinary methods of carbonization, the best possible yield of the richest attainable tar would naturally be sought, provided good prices for tar products ruled. Further, the general adoption of any process which enriches the gas at the expense of the tar is of no little moment to color makers, who would see their raw material vanishing. Nevertheless, any plan which gives gas managers a fuller control over the quantity and character of their output, and throws light on the chemistry of gas making, must always be welcome.

Oil in India.

The location of new sources of petroleum in India still goes merrily on. Since the beginning of the year extensive deposits have been brought to light in new districts near Quetta, in several places close to the Khyber Pass, in the Punjab, and again in Upper Burmah, quite remote from the well known oil fields at Yenangyoung. Those near the Khyber Pass are to be shortly investigated, as they promise to provide fuel for the railway that sooner or later will run from India to Cabul. A survey of this line, as we stated a short time ago, has been ordered by the Indian authorities. Meanwhile, it is interesting to know on the authority of Mr. Boverton Redwood, our ablest technical expert in petroleum in this country, that the supply of oil at the Khatun petroleum fields is ample for the requirements of the Quetta Railroad. Five wells have been bored up to now, yielding each 400 to 600 barrels of oil a day, and the supply of any one of the five would be ample for the present fuel demand of the railway. In a lecture before the Society of Chemical Industry a few days ago Mr. Redwood declared the Beluchistan petroleum fields to be the best, as regards copiousness, in all India. The oil fields there belong to the State, the wells have been sunk at the expense of the government, and already have given such satisfactory results in regard to fuel that the saving will more than cover all the expenses incurred in well sinking up to now. The Beluchistan petroleum is heavier than the Baku oil, and by the present methods of distillation does not yield so much illuminating oil; but a recent discovery by Mr. Redwood and Professor Dewar in distilling heavy crude and waste oils has rendered it possible for the Beluchistan oil to yield 40 per cent. of kerosene, as compared with the 30 per cent. obtained from Baku petroleum. This discovery, the result of years of chemical research, promises to occasion a complete revolution in petroleum by bringing into use vast quantities of heavy crude oils hitherto considered too difficult for the refiner to deal with. This applies to Burmah quite as much as to Beluchistan. While drilling operations have been successfully progressing near Quetta large supplies have been tapped in Assam, and the American wells sunk in Upper Burmah have struck oil to an extent that would be considered most satisfactory either in Galicia or in the United States. The enormous gushers at Baku, however, have excited the appetite for similar abnormal wells elsewhere. It is forgotten that the real criterion of the value of a well is not the quantity of oil that flows up from it, but the market available for it on reaching the surface. In this respect the Caspian oil fields are so handicapped by difficulties of transport that a 50-barrel well in the States is a better one to own than a well yielding 5,000 barrels a day at Baku.

Resistance to Fire of Wood Posts.

The endurance of wood posts when subjected to the action of fire, is strikingly shown in a fire which occurred in a warehouse of enormous proportions, and raged with great fury for five hours, at the end of which time it was extinguished. According to the *Architect* (London) the warehouse was constructed of brick walls; it had wooden floors sup-

ported on wooden beams, which, in their turn, were carried on wooden story posts about twelve inches thick, and, although serious damage was done, not one portion of the heavy wood work was destroyed. After the fire, the proprietors allowed the chief of the fire brigade to remove one of the story posts, with a section of the beams and other parts surrounding it above and below. This post had been subjected to the full action of the fire during the whole of its duration, as already mentioned, or, making full allowance for everything, including the delay of the fire attacking the particular spot on which it stood, and the time at which the cooling process commenced, certainly not less than four and a half hours. As large quantities of water had been used, and it was probable that everything had been saturated, the wood was carefully dried before a strong fire until not a trace of moisture remained in it. It was then set on end in an open yard, exactly as it had stood in the warehouse, with the pedestal underneath, the cap above, and the beam across the cap. More than a ton of shavings, light wood and heavy wood were placed around it, and after the whole heap was saturated with petroleum, a light was applied to it, and after this large quantities of petroleum and turpentine were pumped on it. At the end of two and one half hours, the post, beam and other parts were withdrawn from the fire, and within a few minutes of the time they were withdrawn they ceased to burn. A few feet were then sawed off horizontally, at that part which had suffered most from the flames, and afterward the same piece was split longitudinally with steel wedges, in order to examine its condition. The post was of pitch pine—about the most inflammable wood known—and yet after exposure for seven hours to fire, the fury of which could not be exceeded, except in blast furnaces, it contained within a quantity of perfectly uninjured and apparently fresh wood, probably capable of supporting the whole weight which the original post was designed to carry. Immediately after the saw cut, and again after the cleaving with steel wedges, the center was carefully examined, and found to be just perceptibly warm to the touch, but nothing more, thus proving that the fiber, in which the strength lay, was quite uninjured.

ITEMS OF INTEREST FROM VARIOUS LOCALITIES.

AT the meeting of the Electric Construction Company, Rockland, Maine, the following officers were elected: President, A. M. Copp; Treasurer and Agent, G. C. Moses; Clerk, Chas. T. Frost; Directors, Messrs. G. C. Moses and F. H. Twitchell, of Bath, Me., C. T. Frost, of Rockland, Me., and F. H. Odiorne and A. M. Copp, of Boston, Mass. It pleases us to add that Mr. Chas. T. Frost was recently presented by the stockholders of the old Rockland and Thomaston Gas Company, in whose service he acted capably and conscientiously for a period of 17 years, with a handsome gold watch and chain in recognition of those services. Those acquainted with the lighting situation in Rockland will not be very greatly out of the way in supposing that the Electric Construction Company of that city is not inimical to the local gas interests.

WE understand that the plant and franchises of the Moberly (Mo.) Gas Light Company have been purchased by Messrs. Hammett & Davison, of Kansas City, the consideration having been \$22,500.

A CORRESPONDENT writing from Macon, Ga., under date of May 22d, says that "the people of this city will have to pay higher rates for incandescent electric lighting than those now prevailing. There can be no doubt that the Macon Gas Light and Water Company has been losing money on the current schedule—from \$1 to \$1.23 per lamp per month, the difference to be charged to hours during which current was supplied—and like a prudent retailer it has determined to place the price where a living profit can be made. As I understand it the rates will be raised to \$1.50 up to \$2 per lamp per month, the difference as before being based on hours of service and number of lamps in use. The schedule will take effect on June 1st, and I am curious to see whether this increase will not put an end to the determination said to have been reached by the Company some time ago to increase the capacity of the incandescent electric plant by something like a 500-light machine. In my opinion the addition will not be needed; for a 16-candle power incandescent lamp, at \$1.50 per month, even admitting that it could be used by the consumer whenever required by him, will not be near so economical as a gas burner supplied with gas of the quality now sent out in Macon, at the rate per thousand at present charged.—E. S."

THEY mean to have another opinion on this matter in Massachusetts—i.e., of conferring the right on cities and towns to manufacture and distribute electric light, gas light, etc.—for, following the Attorney-General's adverse decision in respect to it, Speaker Barrett, of the House,

succeeded recently in securing unanimous consent of the Assembly to a resolution asking that "the opinion of the Supreme Court of the State be required upon the question whether or not it is within the constitutional powers of the Legislature to confer upon cities and towns the right to manufacture gas or electric lights for use or for sale."

A NEW exhauster, rated to a duty of 200,000 cubic feet per diem, has been installed at the Northampton (Mass.) works.

FOLLOWING our notice of the proposed construction of a gas works in Summit, N. J., we may remark that the incorporators recently applied to the Township Committee for permission to open the streets and roads of the town for the purpose of putting down gas mains. The Committee, having looked over the application, returned the following answer thereto: "Your application * * * was considered. The Committee are in favor of granting the permission asked, but will require in return an agreement in regard to the proposed methods of doing the work, the time within which it is to be done, price of gas to be furnished citizens, and perhaps some other particulars which may be regarded as proper and necessary for the protection of the township, and which can only be made after the Gas Company has been fully organized. * * *." This, of course, sounds only proper, pretty and polite; but the real matter behind it all is that the proposition to operate a gas company in Summit has aroused the opposition of certain parties who wish to secure a contract for public lighting in the township by means of electricity. That this opposition has friends in the Committee is possibly well proven by the submission of the following resolution that was passed at the meeting of the Committee at which the Gas Company's application was so politely referred back. The resolution is: "Resolved, that it is the sense of the Township Committee that the contract for lighting the streets and roads of this Township should be awarded to a company or individuals who will offer and guarantee for such lighting electricity, and furthermore that such system of lighting is to-day the most effective and economical for the public lighting of the Township of Summit." This pronouncement takes on a closer resemblance to the celebrated "resolve" of the Tooley street tailors of ancient renown when it is borne in mind that the Committee is known to favor "incandescent electric lights of 25 candle power nominal," to the exclusion of manufactured gas. The crab-like advancers on the Township Committee need not go out of their own State—in fact they could easily walk over to Elizabeth—to examine one of the best lighted towns in the State, always excluding those in which the arc light is used—where gas is used for street lighting purposes, and then, if not too fatigued with the exertion, just take another pedestrian tour to Mount Holly—on sober second thought, perhaps they might better "take the cars" to the latter place—where a beautiful (?) specimen of incandescent electric public lighting is to be seen, if they desire proof that they write themselves down as asses in the assertion "that such system of lighting [incandescent electric] is the most economical and effective for the public lighting of the Township of Summit."

MR. NELSON SMITH, formerly of Newmarket, N. H., has been appointed Manager of the Ipswich (Mass.) Gas Company.

THE proprietors of the Salem (Mass.) Gas Company are to be complimented on the excellently arranged display of gas cookers and heaters now being made in the Museum Building in that city.

AT the annual meeting of the Winona (Minn.) Gas Light Company the following officers were elected: President, H. W. Lambertson; Vice-President, Henry Stevens; Secretary and Manager, H. C. Bolcom; Directors, the officers and Judges Thomas Wilson and William Mitchell, and F. M. Cockrel. The Company enjoyed a most prosperous year, and will duplicate this result, if not exceed it, when the returns for the current twelvemonth are in.

"THE annual meeting of the Portland (Me.) Gas Light Company, which was held something over a week ago, was called to order in the new office building recently completed for the proprietors on Temple street. It is a three storied affair, the lower floor being used as a meter-repairing shop, the offices occupy the second floor, and the third floor is arranged in apartments for the President and Treasurer. The building, which was erected under the direction of architects Fassett and Thompson, is really a credit to those who had anything to do with it, and is an addition of note to the many handsome building structures of the city. I do not suppose your readers are very greatly interested in matters of this sort but I must say that the ash-finishing of the apartments is really artistic, and I make bold to say that some visiting gas men will go away with the impression that they wished they 'had something at home' like

the Portland Company's new quarters. The meeting was well attended, and I presume I can hardly do better, by way of showing what the Company has done during the year, than give the following from President Daveis' annual report—it should be borne in mind in looking at the send-out figures that pretty much all the public lighting was done last year by electricity, and that Superintendent Yorke has been fixing up the mains of the Company: 'The consumption of gas for the year ending April 30, was 50,470,000 cubic feet, against 49,856,000 last year, a gain of 614,000 cubic feet. The number of consumers on the 1st inst. was 2,972, an increase of 51. There have been carbonized 4,984 tons of coal and 85 tons of oil, yielding 55,000,000 feet of gas, averaging 18.9 candle power. There have been sold 86,317 bushels of coke, 3,950 bushels of coke breeze and 90 barrels of tar. There have been laid 2,382 feet of mains, in West, Clark, Crescent, Gilman, Congress, Brackett, Taylor, Neal, Wescott, Carroll and Oak streets. A new exhauster has also been placed; a lot of land was bought on Temple street, and a new office has been built upon it, and nearly completed, at a total cost thus far of \$8,250, which has been paid out of our renewal and insurance funds. For the coming year we shall purchase and set 45 new retorts, costing, with the tiles, etc., about \$4,000. We shall build a new sewer through the sea wall costing about \$360. No other extraordinary repairs at the works are expected to be required, unless the old holders should give out. This is liable to happen at any time, and it will take a large part of our reserved fund to build a new one. A new meter prover has also been installed.' When the report was adopted an election was entered into, with the following result: President, Edward H. Daveis; Treasurer, Samuel Rolfe; Directors, E. H. Daveis, W. W. Thomas, Chas. B. Merrill, W. H. Moulton, Fred. N. Dow and John F. Rand. The other feature of importance was the declaration of a dividend of \$2.50 per share, payable to-morrow. The new office building was, of course, properly baptized. It gives me pleasure to add that a more harmonious working board does not exist in any other corporation in far-away Maine than that which directs the affairs of the Portland Gas Light Company.—OBSERVER."

THE new buildings of the David E. Paris Stove Company, at Sioux City, Ia., will be built of iron by the Berlin Iron Bridge Company, at the latter's shops at East Berlin, Conn. The foundry building will be 155 feet wide by 350 feet long, the mounting room 87 feet wide by 225 feet long, and the boiler, engine and plating room 50 feet wide by 196 feet long. The Berlin Iron Bridge Company also have the contract for the new foundry building of the Waterbury-Farrel Foundry and Machine Company.

THE name of the firm of Rumsey & Sigmeyer was omitted from the souvenir programmes for the outing-time of the recent St. Louis convention of the Western Association, through a mistake of the printers who were entrusted with the work. Very likely the "intelligent printer" concluded that Rumsey and Sigmeyer and the L. M. Rumsey Mfg. Company were identical, and that separate publication would be duplication. The correction is made now. And we might add that both firms were liberal contributors to the entertainment fund.

THE St. Louis *Globe-Democrat* says that the opposition which began in Europe against antipyrin, as a dangerous agent for the reduction of fever and the abatement of pain, has been the indirect cause of the introduction of a new remedy of the same class and the same general origin. It is called antikamnia, and is a product of coal tar, as is antipyrin. The new medicine is said to be a certain remedy for headache, neuralgia, locomotor ataxia, sciatica, and in fact for all pains that can be reached by medicine taken into the stomach and diffused into the blood. Antikamnia does not excite the heart, nor does its use grow into a habit, as it contains neither opium, cocaine, nor any other dangerous drug or chemical. It does not produce gastric disturbances.

MR. THEO. B. WELLS, as Secretary of the corporation, gives notice that the name of the Chicago Gas Trust Company has been changed to Chicago Gas Company, by virtue of and in accordance with the provisions of the statute of the State of Illinois in regard to the change of name of corporations. All holders of certificates of the capital stock of said corporation are notified to present such certificates to the respective transfer offices of the Company at which the certificates they hold were issued, to be exchanged for certificates bearing the new name of the corporation. Certificates issued from the Chicago transfer office are to be presented at the Union National Bank, Chicago; those issued from the Philadelphia transfer office are to be presented at the Fidelity Insurance, Trust and Safe Deposit Company, of Philadelphia; and certifi-

ates issued from the New York transfer office are receivable at the Central Trust Company, of New York.

THE proprietors of the Minneapolis (Minn.) Gas Light Company are also speeding on the good work of introducing the use of gas in kitchens, and in furtherance of this object, among other things, have distributed throughout the city copies of the following circular, which we think is worth reprinting:

What does it Cost?—In seeking to introduce the use of gas stoves we are frequently asked the question, "What does it cost to operate a gas stove?" We know of no better way to answer the question than by giving a statement of the actual experience of those using gas exclusively for light and for cooking and laundry purposes. The subjoined statement is one prepared from our books, and is the actual experience of 14 families, living in apartment houses where there are no means for light or cooking except by gas. It must also be borne in mind that the averages and monthly bills are for light as well as for cooking, as but one meter is used for each consumer, and there is no method of separating the amount used for light from the amount of gas used for cooking. We have selected 5 months of the year when the use of gas for lighting is heaviest, and in the face of the statement we maintain that the use of gas for cooking and lighting is one of the cheapest necessities one can have. Another strong point in favor of gas as a fuel is the absolute freedom from danger; no fuel to handle; no ashes; no soot; no bad cooking. We invite your inspection of our sales department, where we carry in stock all the most improved gas stoves, burners and appliances, which are for sale to our customers at cost prices.

Statement.

Name.	Gas Bill for Nov. 32 Days.*	Gas Bill for Dec. 29 Days.*	Gas Bill for Jan. 31 Days.*	Gas Bill for Feb. 29 Days.*	Gas Bill for Mar. 29 Days.*	Total for Five Months.	Cost per Day for Cooking and Light.
T. A.	\$6 66	\$8 28	\$5 94	\$7 32	\$6 48	\$34 68	23 cents.
C. S.	13 14	3 96	7 92	9 54	7 92	42 48	28 "
F. A. P.	18 20	13 32	12 62	12 96	13 86	70 96	47 "
F. B. S.	16 92	16 38	16 20	16 74	14 94	81 18	54 "
W. J. K.	7 56	7 02	7 56	7 20	7 56	36 90	25 "
T. K.	72	3 06	2 34	2 88	2 52	11 52	7 "
W. S. D.	10 98	10 98	10 26	7 92	5 40	45 54	30 "
J. S.	4 80	4 86	5 76	3 42	3 24	22 08	15 "
J. A. C.	6 12	4 86	10 80	1 44	19 08	42 30	28 "
G. C. R.	21 34	17 46	14 58	13 68	10 80	77 86	52 "
F. J. L.	7 56	8 28	7 56	5 58	9 90	29 88	20 "
M. F. T.	6 84	5 94	5 04	4 32	5 22	27 36	18 "
C. F. N.	9 36	8 10	5 40	7 74	9 54	40 14	27 "
T. H. D.	9 18	9 18	11 16	9 18	7 38	46 08	31 "
Total.....	\$139 38	\$121 68	\$123 14	\$109 92	\$114 84	\$608 96	
Av. monthly bill..	\$9 29	\$8 11	\$8 20	\$7 85	\$8 20		

*Total days, 150.

THE latest oddity in "steals" is reported from the works of the Rochester (N. Y.) Gas Light Company, which mourns the loss of an 800 pound iron "drip" that was taken from the storage yard by a thief named John Gleisch. He has been impounded.

THE Managers of the Pottstown (Pa.) Gas and Water Company met on the evening of May 24th to award the contracts for their new reservoir, with pumping station, water mains, etc., the estimated cost of which is put at \$125,000. There were eight bids tendered for the reservoir work, and seven bidders handed in figures for the pipe laying and the pumping machinery. The contract for laying something over three miles of water mains was awarded to Howard E. Ahrens, of Reading, but the

reservoir and pumping station contracts were deferred. The Mellert Foundry and Machine Company got the contract for 1,500 tons of 20, 24 and 30-inch water mains.

THE Pennsylvania Globe Gas Light Company wants to perform the public lighting of Chester, Pa., by means of gasoline lamps. On a moontable they offer to light, extinguish and maintain each lamp, on a yearly contract, at \$23; on a two year contract, at \$22; on a five-year contract, at \$21.50.

THE Managers of the Capital City Gas Light Company have over 400 gas stoves now in service in Des Moines, Iowa, and Superintendent Pratt is confident that at least 600 will be in duty by October 1st. The handsome corner store in the Hotel Savery building has been rented as a show-room, and it is stocked with a large and varied selection of the best makes of gas ranges, cookers, broilers, heaters, etc. Mr. H. D. Willis, with a goodly number of assistants, will instruct the visitors in the art of gas cooking. This, of course, will be a permanent thing, and cannot fail of being profitable. To boom "the opening" the Company engaged Miss Stiles to deliver a course of 9 lectures on the art of gas cooking, the lecture hall being located in the Commercial Exchange Room. Miss Stiles illustrated her lectures in using a gas stove in full view of her audience. The first of the course (given on May 20th) was a lecture on bread making, and to this seance no admission was charged. Tickets for the remaining lectures have been placed at 50 cents for a single lesson, or \$3 for the course. The other lessons were arranged for as follows: On May 22d, subject, "Soups;" May 24th, "Fish;" May 26th, "Roasts;" May 28th, "Entrees;" May 30th, "Salads;" June 2nd, "Pastry;" June 4th, "Delicate Dessert;" June 6th, "Eggs and Omelettes." So far as heard from the lectures have been well delivered and well attended, which is perhaps the best augury for the future. Miss Stiles, who is a graduate of the Kansas City School of Household Science, has good command of her subject, and expresses herself so that her auditors are never mystified. The Company sets the stoves at net cost for apparatus and labor, and has made the special rate of \$1.50 per 1,000 cubic feet for gas used for purposes other than lighting. There can be no doubt about it that the Capital City Company's day sendout will soon figure as an important factor in its business.

THE latest news from St. Joseph, Mo., is to the effect that articles have been filed incorporating the St. Joseph Light and Fuel Company, the proprietors of which intend to assume the "rights, franchises, and privileges" recently granted to one Charles McGuire by councils for the operation and maintenance of a light and fuel gas works in that city under the Fahnehjelm system. The capital stock of the Company is put at \$500,000, divided into 5,000 shares, which are said to be held as follows: Charles McGuire, 800 shares; O. M. Spencer, 800; J. W. Heddens, 800; George E. Black, 800; John Donovan, Jr., 800; D. D. Burns, 800; J. G. Schneider, 200. Well, what next?

WE desire to call especial attention to the advertisement on page 779 of our current issue, inserted at the instance of Mr. William Daley, Engineer and Manager of the city of Dunedin Suburban Gas Company, Limited, of Caversham, New Zealand. The advertisement explains itself completely, and we have only to add that Mr. Daley is a thoroughly reliable man, who can be depended on to redeem all his promises. Our burner makers will likely find it to their interest to be represented at the proposed exhibition, and they should also bear in mind that as New Zealand is well on the other side from us no delay should be permitted in the matter of forwarding their parcels.

THE permanent residents of Coney Island are clamoring for an extension of the public lighting system. In fact under the present arrangement the Island might as well be without any public lamps, so injudiciously have the latter been located.

THE Yonkers (N. Y.) Gas Light Company's wharf, at the foot of Babcock street, is to be further improved.

THE proprietors of the Anniston (Ala.) Gas and Light Company, in order to increase the use of gas for purposes other than lighting, have put the rate for cooking, heating and power at \$1.75 per 1000 cubic feet. They will also supply and install the necessary stoves, etc., at net cost.

ELSEWHERE we make mention of the presentation to Mr. Charles T. Frost, by the holders of the Rockland and Thomaston (Me.) Gas Company, of an elegant gold watch and chain as a testimonial of their appreciation of his faithful and efficient services, covering a period of 17

years. Since that item was written we have received from a valued correspondent some further account of the presentation and of the services that led up to it. Our correspondent remarks: "I enclose you an account of the presentation to Mr. Chas. T. Frost, by the stockholders of the Rockland and Thomaston Gas Company, of a handsome gold watch and chain. Mr. Frost, who served the Company for 17 years as Superintendent, is well known to the Eastern fraternity, and that the testimonial is merited can be understood from the fact that the sendout of the Company has increased during his term of office from 1,300,000 cubic feet to 4,000,000 cubic feet, and the rate has been cut from \$4.50 per 1,000 to \$2.50 per 1,000. Again, not only have the works been gradually rebuilt out of earnings, but a dividend paying basis of 6 per cent. per annum has been reached. The former shareholders of the Company, having received an offer for their stock from certain capitalists more or less interested in local electric lighting ventures, agreed to sell out their holdings, hence the property is now in new control as to ownership, but its management still remains in the hands of Mr. Frost. He will also have charge of the electric annex. The outlook for the Company is of the most promising kind.—H. R."

THE property of the Edison Electric Light Company, Sunbury, Pa., is in the hands of the sheriff, because of an attachment sued out by D. D. Heim & Co., for \$1,610.76.

THE bill before the Massachusetts Legislature authorizing the consolidation of gas and electric light companies has been ordered to a third reading in the House, and it looks as if the measure would eventually become a law.

SUPT. HAYDEN has completed the work of overhauling the main system of the Fishkill (N. Y.) Gas Company, and as a result the Company has been enabled to announce a reduction in gas rates. The new schedule ranges from \$2 to \$2.25 per 1,000 for lighting purposes, the rate for fuel gas (through separate meter) being fixed at \$1.75. The former schedule called for a payment of \$2.25 to \$2.50, without any rebate on gas used for fuel purposes.

THE annual meeting of the Knoxville (Tenn.) Gas Light Company will be held on Friday.

THE electric annex of the Grand Forks (N. Dak.) Gas and Electric Light Company is driven by gas motors (70-horse power), and the scheme gives great satisfaction. The Thomson-Houston system is employed, and the dynamic capacity is equal to the maintenance of 1,200 incandescents (16-candle power), and 30 arcs of 1,200-candle power each. Superintendent Raycraft, however, thinks that the gaseous end of the establishment is the one that will earn the most money.

THE Appleton (Wis.) Fuel Gas Company is bound under its charter to supply street lights at \$20 each per annum, fuel gas for 75 cents per 1,000, and lighting gas for 90 cents.

The Market for Gas Securities.

The city market for gas shares was not particularly active during the week, although values in Consolidated were fairly well maintained. Today (Thursday, May 29) the shares are bid for at 103, with no stock offering. The action of the Trustees of the Company, in settling upon the rate of dividend for the past six months, effectually settled the hopes of those who looked for an increase. They determined that 2½ per cent. would be about the right thing, and the dividend checks will bear the date of June 14. There is no doubt whatever that the Company's earnings for the past six months would easily permit of a raise to 3 per cent., and there can be no doubt either that the refusal of the Trustees to change the rate is worthy of praise as a prudential measure. It is good management and careful financiering. That the floating stock on the market has found its way into strong hands is best shown in the fact that a 5 per cent. manufacturing company's securities are held above par. We consistently and constantly urged the purchase of these shares from the time they were first placed on the market, and we further advise their purchase now. We will also add that it is odds on that the next dividend declared will bring the rate to 6 per cent.

Citizens gas of Brooklyn is up to 82, and it may go higher. Other city and Brooklyn shares fully hold their own. The event of the week, however, was the decision of Judge Collins, of Chicago, in the suit of Charlton against the Chicago Gas Trust. The Judge sustained Charlton's side of the argument, and ordered that a Receiver be appointed to take charge of the Trust's affairs, and enjoined it from transferring its stock holdings, moneys, etc., to the Fidelity Insurance, Trust and Safe Deposit Company, of Philadelphia. Under this news the market broke from 62½ to 55½ on Wednesday, closing at 55½. To-day the opening price was 51½, and the tone was weak. Why holders should feel so panicky we cannot understand. There has been no Gas Trust for some time, hence we fail to see why shares in its successor, the Chicago Gas Company, are not worth to-day what they were worth yesterday in open market. Judge Collins and Mr. Charlton are a trifle late in their efforts to really injure the property, even though the market was successfully "beared" by them. Even judges cannot destroy property, hence we imagine that Chicago gas is a good thing to buy at present figures, although perhaps the lowest notch has not yet been reached in it. The general outlook is favorable.



A. M. CALLENDER & CO.,

PROPRIETORS.

EDITOR—JOS. R. THOMAS, C.E.

ASST. EDITOR—T. J. CUNNINGHAM.

MANAGER—C. E. SANDERSON.

PUBLISHED ON EACH MONDAY OF THE YEAR AT
No. 42 Pine Street, New York.

This is a recognized official organ of
LIGHT, HEAT, STEAM, WATER SUPPLY,
VENTILATION, SANITARY IMPROVEMENT,
AND GENERAL SCIENCE

TERMS:

SUBSCRIPTION—Three Dollars per annum, in advance. Single copies, 10 cents.

AGENTS.

NEW YORK.—AMERICAN NEWS CO., 39 and 41 Chambers Street.
PHILADELPHIA.—PRATT & CO., Corner Ninth and Arch Streets.
Germany.—B. WESTERMANN & CO., of New York.

MONDAY, JUNE 2, 1890.

Gas Stocks.

Quotations by Geo. W. Close, Broker and Dealer in Gas Stocks,
16 WALL ST., NEW YORK CITY.

JUNE 2.

All communications will receive particular attention.
The following quotations are based on the par value of \$100 per share.

	Capital.	Par.	Bid	Asked
Consolidated.....	\$35,430,000	100	103	—
Central.....	500,000	50	85	95
“ Scrip.....	220,000	—	95	100
Equitable.....	4,000,000	100	120	—
“ Bonds.....	1,000,000	—	113	115
Harlem, Bonds.....	170,000	—	—	—
Metropolitan, Bonds...	658,000	—	115	—
Mutual.....	3,500,000	100	114	—
“ Bonds.....	1,500,000	—	100	—
Municipal, Bonds.....	750,000	—	—	—
Northern.....	—	50	—	—
“ Bonds.....	150,000	—	—	100
Standard Gas Co—				
Common Stock.....	5,000,000	100	—	45
Preferred.....	5,000,000	100	84	87
Yonkers.....	—	50	112	—
Richmond Co., S. I.....	346,000	50	—	—
“ Bonds.....	20,000	—	—	—
Gas Co's of Brooklyn.				
Brooklyn.....	2,000,000	25	116	120
Citizens.....	1,200,000	20	82	82½
“ S. F. Bonds...	320,000	1000	100	105
Fulton Municipal.....	3,000,000	100	132	—
“ Bonds....	300,000	100	102	—
Peoples.....	1,000,000	10	90	92
“ Bonds (7's).....	368,000	—	100	—
“ “ (6's).....	94,000	—	100	—
Metropolitan.....	1,000,000	100	108	110
Nassau.....	1,000,000	25	125	—
“ C'tfs.....	700,000	1000	100	—
Williamsburgh.....	1,000,000	50	128	—
“ Bonds... ..	1,000,000	—	108	112

Out of Town Gas Companies.

Boston United Gas Co.—				
1st Series S.F. Trust	7,000,000	1000	93	93½
2d “ “ “	3,000,000	1000	71	72
Bay State Gas Co.—				
Stock.....	5,000,000	50	84	—
Income Bonds.....	2,000,000	1000	94½	95½
Buffalo Mutual, N. Y...	750,000	100	90	95
“ Bonds...	200,000	1000	95	100
Citizens, Newark.....	1,000,000	50	155	160
“ “ Bonds.	45,000	—	—	—
Chicago Gas Company.	25,000,000	100	52	52½
Chicago Gas Light & Coke Co.—				
G't'd Gold Bonds	7,650,000	1000	97½	98½
Equitable Gas & Fuel Co., Chicago, Bonds	2,000,000	1000	94½	95½
People's Gas and Coke Co., Chicago—				
1st Mortgage.....	2,100,000	1000	—	100
2d “	2,500,000	1000	96	100
Consumers Gas Light Co., Jersey City.....				
Bonds.....	600,000	1000	80	—
Cincinnati G. & C. Co..	6,000,000	100	201	203
Consumers Toronto....	1,000,000	50	190	200
Central, S. F., Cal.....	—	—	80	90
Capital, Sacramento, Cal	—	—	58	—
Consolidated, Balt.....	11,000,000	100	52	52½
“ Bonds.....	6,400,000	—	107	107½
Citizens Gas Lt. Co., Rochester, N. Y.....				
Bonds.....	500,000	—	75	90
Hartford, Conn.....	750,000	25	102	108
Jersey City.....	750,000	20	170	175
Laclede Gas Light Co., St. Louis, Mo.—				
Common Stock....	7,500,000	100	23¾	—
Preferred “	2,500,000	100	68	70
Bonds.....	9,034,400	1000	87	87¾
Louisville, Ky.....	2,570,000	50	125	130
Little Falls, N. Y.....	50,000	100	—	100
“ Bonds	25,000	—	100	103
Montreal, Canada.....	2,000,000	100	200	208
Memphis (Tenn.) Gas...	750,000	100	40	—
“ Bonds.	240,000	100	103	—
New Haven, Conn.....	—	25	200	—
Oakland, Cal.....	—	—	35	35½
Peoples, Jersey City... ..				
“ “ Bonds..	—	—	60	61
Paterson, N. J.....	—	25	99	102
Rochester, N. Y.....	—	50	99	100
Syracuse, N. Y.....	500,000	25	—	—
San Francisco Gas Co.				
San Francisco, Cal....	10,000,000	100	55½	55¾
Washington, D. C.....	2,000,000	20	200	208
Wilmington, Del.	—	50	88	90

Advertisers Index.

GAS ENGINEERS.		Page
Jos. R. Thomas, New York City		789
Wm. Henry White, New York City.....		795
Wm. Mooney, New York City.....		789
William Gardner, Pittsburgh, Pa.....		789
Fred. Bredel, N. Y. City.....		791
GAS WORKS APPARATUS AND CONSTRUCTION.		
James R. Floyd & Sons, New York City		795
Continental Iron Works, Greenpoint, L. I.....		795
Delly & Fowler, Phila., Pa.....		795
Kerr Murray Mfg. Co., Fort Wayne, Ind.....		792
Stacey Mfg. Co., Cincinnati, Ohio.....		795
Bartlett, Hayward & Co., Baltimore, Md.....		793
Morris, Tasker & Co., Limited, Phila., Pa.....		793
Davis & Farnum Mfg. Co., Waltham, Mass.....		792
R. D. Wood & Co., Phila., Pa.....		794
Bouton Foundry Co., Chicago, Ills.....		795
Smith & Sayre Manufacturing Co., New York City.....		794
Fred. Bredel, N. Y. City.....		791
United Gas Improvement Co., Phila., Pa.....		785
National Gas Light and Fuel Co., Chicago, Ills.....		782
Stimpkin & Hillyer, Richmond, Va.....		743

GAS AND WATER PIPES.

Gloucester Iron Works, Phila., Pa.....	789
Mellert Foundry and Machine Co., Reading, Pa. (John Fox, Selling Agent, N. Y.).....	789
Ohio Pipe Co., Columbus, Ohio.....	789
M. J. Drummond, New York City.....	789
R. D. Wood & Co., Phila., Pa.....	794
Warren Foundry & Machine Co., New York City.....	789
Donaldson Iron Co., Emaus, Pa.....	789
Dennis Long & Company, Louisville, Ky.....	789

PROCESSES.

National Gas Light and Fuel Co., Chicago, Ills.....	782
Bartlett, Hayward & Co., Baltimore, Md.....	793
Wm. Henry White, N. Y. City.....	795
United Gas Improvement Co., Phila., Pa.....	785

INCLINED RETORTS.

Laclede Fire Brick Manuf'g Co., St. Louis, Mo.	780
---	-----

GASHOLDER TANKS.

W. C. Whyte, New York City.....	782
J. P. Whittier, Brooklyn, N. Y.....	787

GASHOLDER PAINT.

The Government Waterproof Paint Co., Boston, Mass.....	780
--	-----

RETORTS AND FIREBRICK.

J. H. Gautier & Co., Jersey City, N. J.....	790
B. Kreischer & Sons, New York City.....	790
Adam Weber, New York City.....	790
Laclede Fire Brick Manuf'g Co., St. Louis, Mo.....	790
Brooklyn Retort and Fire Brick Works, Brooklyn, N. Y.....	790
Borgner & O'Brien, Phila., Pa.....	790
James Gardner, Jr., Pittsburgh, Pa.....	70
Henry Maurer & Son, New York City.....	791
Chicago Retort and Fire Brick Co., Chicago, Ills.....	790
Baltimore Retort and Fire Brick Co., Baltimore.....	790
Oakhill Gas Retort and Fire Brick Co., St. Louis, Mo.....	790
Boston Fire Brick Works, Boston, Mass.....	780

SCRUBBERS AND CONDENSERS.

G. Shepard Page, New York City.....	781
R. D. Wood & Co., Phila., Pa.....	781

REGENERATIVE FURNACES.

Bartlett, Hayward & Co., Baltimore, Md.....	793
Fred. Bredel, New York City.....	791
Chicago Retort and Firebrick Co., Chicago, Ills.....	790
J. H. Gautier & Co., Jersey City, N. J.....	791

GAS GOVERNORS.

Connelly & Co., New York City.....	787
Fred. Bredel, N. Y. City.....	791
Friedrich Lux, London, England.....	779

SELF-SEALING MOUTHPIECE DOORS.

Smith & Sayre Mfg. Co., New York City.....	794
--	-----

TAR AND CARBONIC ACID EXTRACTOR.

Geo. Shepard Page, N. Y. City.....	748
------------------------------------	-----

CEMENTS.

C. L. Gerould & Co., Brooklyn, N. Y.....	790
--	-----

GAS ENRICHERS.

Standard Oil Co., Cleveland, Ohio.....	796
--	-----

GAS METERS.

John J. Griffin & Co., Phila., Pa.....	798
American Meter Co., New York and Philadelphia.....	799
The Goodwin Gas Stove and Meter Co., Philadelphia, Pa....	799
Helme & McIlhenny, Phila., Pa.....	799
D. McDonald & Co. Albany, N. Y.....	799
Nathaniel Tufts, Boston, Mass.....	798
Maryland Meter and Manufacturing Co., Baltimore, Md....	744
Bell & Jones, Philadelphia, Pa.....	798
Harris Bros. & Co., Philadelphia, Pa.....	798

EXHAUSTERS.

The P. H. & F. M. Roots Co., Connersville, Ind.....	786
Smith & Sayre Manufacturing Co., New York City.....	794
Wilbraham Bros., Philadelphia, Pa.....	787
Connelly & Co., New York City.....	787

GAS COALS.

Penn Gas Coal Co., Phila., Pa.....	797
Perkins & Co., New York City.....	796
Newburgh Orrel Coal Co., Baltimore Md.....	797
Despard Coal Co., Baltimore, Md.....	797
Chesapeake and Ohio R. R. Coal Agency, N. Y. City.....	797
Westmoreland Coal Company, Phila., Pa.....	797
J. & W. Wood, New York City.....	796

CANNEL COALS.

Perkins & Co., New York City..... 796
 J. & W. Wood, New York City..... 796

VALVES.

Ludlow Valve Manufacturing Co., Troy, N. Y..... 788
 John McLean, New York City..... 788
 Chapman Valve Manufacturing Co., Boston, Mass..... 788
 R. D. Wood & Co., Phila., Pa..... 794
 The P. H. & F. M. Roots Co., Connersville, Ind..... 786

GAS ENGINES.

Schleicher, Schumm & Co., Phila., Pa..... 900
 Clerk Gas Engine Co., Phila., Pa..... 788
 Van Duzen Gas Engine Co., Cincinnati, Ohio..... 788

ENGINES AND BOILERS.

Jarvis Engineering Co., Boston, Mass..... 787
 Ball Engine Co., Erie, Pa..... 780

STEAM PUMPS.

Van Duzen & Tift, Cincinnati, Ohio..... 779

GAS LAMPS.

Welsbach Incandescent Gas Light Co., Phila., Pa..... 781
 The Siemens-Lungren Company, Philadelphia, Pa..... 781
 Fiske, Coleman & Company, Boston, Mass..... 790

PURIFIER SCREENS.

John Cabot, New York City..... 783
 Bartlett, Hayward & Co., Baltimore, Md..... 788

GAS STOVES.

American Meter Co., New York and Philadelphia..... 783
 The Goodwin Gas Stove and Meter Co., Phila. Pa..... 764
 George M. Clark & Company, Chicago, Ills..... 781
 D. McDonald & Co., Albany, N. Y..... 799
 Maryland Meter and Manufacturing Co., Baltimore, Md..... 744
 Bell & Jones, Philadelphia, Pa..... 798
 Chicago Gas Stove Company, Chicago, Ills..... 780

STREET LAMPS.

J. G. Miner, Morrisania, New York City..... 779
 Bartlett Street Lamp Man'g Co., New York City..... 779

BURNERS.

C. A. Gefrorer, Phila., Pa..... 796
 H. W. Rappleye, Philadelphia, Pa..... 868
 Moses G. Wilder, Phila., Pa..... 779

STEAM BLOWER FOR BURNING BREESE.

H. E. Parson, New York City..... 783

PURIFYING MATERIAL.

Connelly & Co., New York City..... 787
 Friedrich Lux, London, England..... 779
 Edgewater Lime Works, Edgewater, N. J..... 780

COKE CRUSHER.

C. M. Keller, Columbus, Ind..... 797

ELECTRICAL APPARATUS.

Wm. Henry White, N. Y. City..... 795

BOOKS, ETC.

Gerould's System Gas Bookkeeping..... 779
 1 90. Directory. 1890..... 787
 King's Treatise..... 789
 Scientific Books..... 791
 Management of Small Gas Works..... 788
 Practical Electric Lighting..... 787
 Electric Light Primer..... 787
 American Gas Engineer and Superintendents' Handbook... 797
 Digest of Gas Law..... 779
 Fuel and its Applications..... 779
 Newhigging's Handbook .. 791

Position Wanted

As Superintendent or Assistant of a Gas Works,
 By a man who can give the best of references. Thoroughly
 understands the manufacture and distribution of gas and the
 construction of works. Address
 779-5 "M." care this Journal.

POSITION WANTED

As Superintendent of Gas Works.
 Eleven years' experience in the manufacture of coal gas. Best
 of references given.
 W. L. CARVER, Supt.,
 Carthage, Mo.
 778-8

FOR SALE,

The Ironwork for Twelve Benches of 6's, viz.:
Cast Iron Hydraulic Main.
7-inch Dip-Pipes, Stand-Pipes, and Bridge-
Pipes, complete.
Floyd Mouthpieces and Self-Sealing Lids, 15x26 in.
 Lids and Mouthpieces only in use over a year. Will be sold
 cheap.
 ISAAC C. BAXTER,
 772-tf Detroit (Mich.) Gas Lt. Co.

To Gas Burner Makers.

WANTED—Samples of all ordinary modern Gas Burners—Union
 Jets, Batwings, Regulating Burners for Oil, Wood, Water, and
 Coal Gas. No Argands. Say four of each, from the smallest to
 the largest. Also samples of old, early, and out-of-date Burn-
 ers, for comparison when lighted. The undersigned is about to
 open a large Exhibition of Gas Burners in Dunedin, N. Z., and
 the makers' names will be attached prominently to respective
 Burners. Samples and lists to be forwarded to the undersigned
 per parcel post.

WILLIAM DALEY, Engineer and Attorney,
 The City of Dunedin Suburban Gas Co.,
 Caversham, New Zealand.

**Who Makes
 TAR SEPARATORS?**

Prices and particulars, address
 "X. Y." care this Journal.

**GEROULD'S
 System Gas Bookkeeping.**

Approved and adopted by many of the prom-
 inent Gas Engineers of the Country.

Sample Sheets and Price-List furnished free on application to
L. P. GEROULD, - - Mendota, Ill.

FRIEDRICH LUX,

Ludwigshafen am Rhein and London.

**Lux Mass,
 GAS GOVERNORS,
 Gas Balance.**

Fuel and Its Applications.

By E. J. MILLS, D.Sc. F.R.S., and F. J. ROWAN, C.E., assisted
 by others, including Mr. F. P. Dewey, of the
 Smithsonian Inst., Wash., D. C.

7 PLATES, AND 607 OTHER ILLUSTRATIONS. ROYAL
 OCTAVO, PAGES XX, 802. HANDSOME CLOTH, \$7.50.
A. M. CALLENDER & CO., 42 Pine St., N. Y.

GREENOUGH'S

"DIGEST OF GAS LAW."

Price, \$5.00.

This is a valuable and important work, a copy
 of which should be in the possession of every gas
 company in the country, whether large or small.
 As a book of reference it will be found invaluable.
 It is the only work of the kind which has ever
 been published in this country, and is most com-
 plete. Handsomely bound. Orders may be sent to

A. M. CALLENDER & CO.,
 42 Pine Street, N. Y.

MOSES G. WILDER, MECH. ENGR.

816-18-20-22 Cherry St., Phila., Pa.

Volumetric Lamp Governors

FOR GAS LAMPS & HIGH-POWER BURNERS.



GOVERNOR BURNERS

for
 STREET LAMPS AND
 GENERAL USE,
 and
 GOVERNORS FOR ARGAND
 AND OTHER COMMON GAS
 BURNERS IN ALL SIZES.

**HORIZONTAL
 Governors**

Specially adapted for
 GAS STOVES, FURNACES,
 Etc., Etc.

It is well known that a large majority of all High Power Gas
 Lamps in the United States have my Governors attached, and
 they are always used by the leading makers of these lamps. To
 remove any excuse for the use by anyone of inferior and in-
 fringing Governors, a reduction in price has been made, and all
 exclusive contracts are cancelled.

Correspondence Solicited with all who require a Reliable
 Governor.



Bartlett Street Lamp Mfg. Co.

MANUFACTURERS OF

Globe Lamps,

FOR
 Streets, Parks, Public
 Buildings, Railroad
 Stations, etc.

LAMP POSTS

A Specialty.

Office and Salesroom,

40 & 42 COLLEGE PLACE, - - N. Y. CITY.

Gas Companies and others intending to erect Lamps
 and Posts will do well to communicate with us.

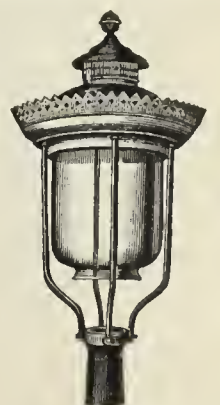
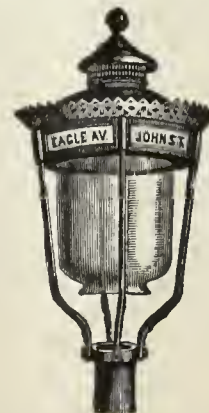

The Miner Street Lamps.

Jacob G. Miner,

No. 823 Eagle Ave., New York, N. Y.

LACLEDE FIRE BRICK MANUFACTURING COMPANY,

ST. LOUIS, MO.

Exclusive Agents in the United States

FOR THE

Coze System of Inclined Retorts.

IT IS THE COMING BENCH FOR MAKING COAL GAS.

It will Save from 50 to 60 per ct. in Labor.

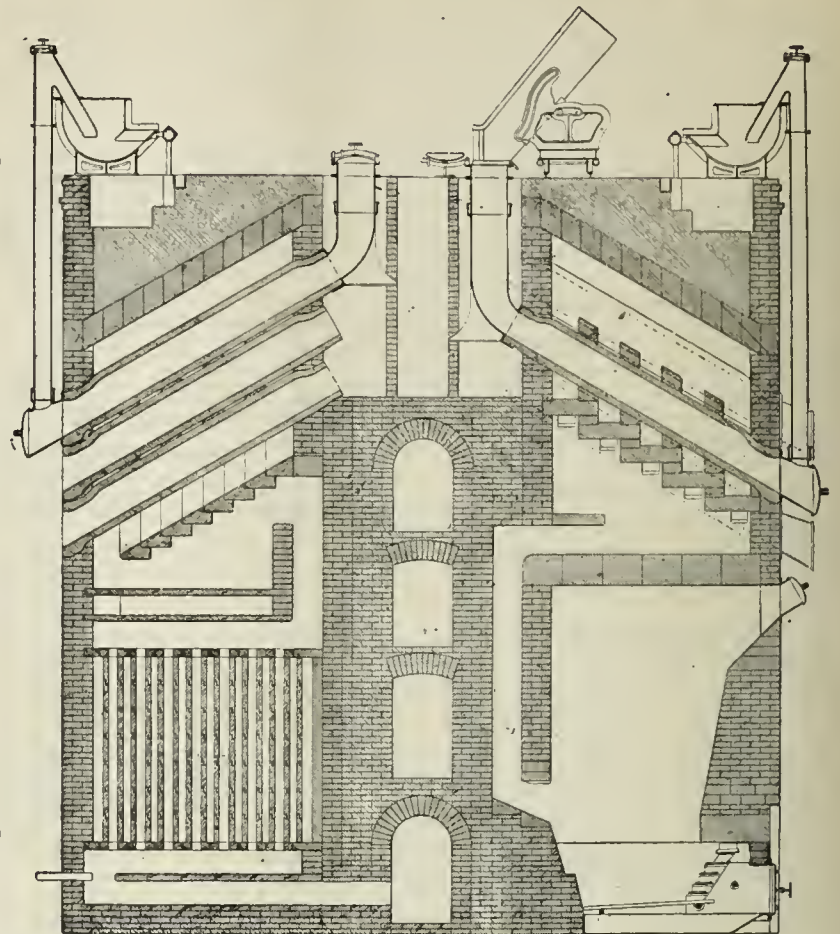
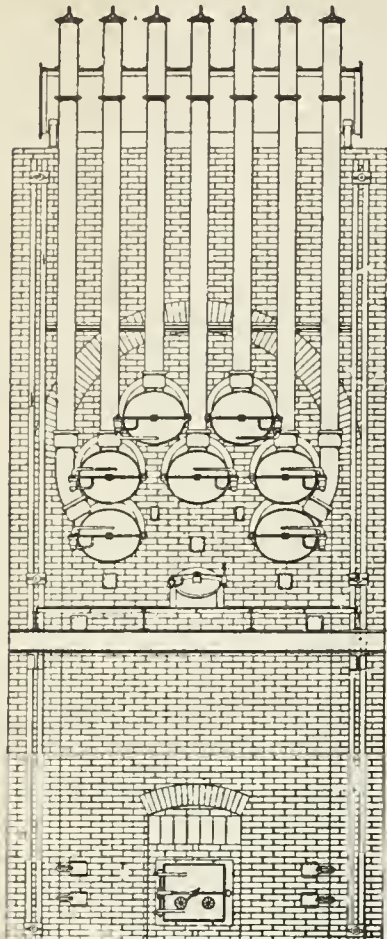

ESTIMATES AND PLANS FURNISHED BY THE

LACLEDE FIRE BRICK MFG. CO., ST. LOUIS, MO.

Simpkin & Hillyer

RICHMOND, VA.

MANUFACTURERS OF

Gas Works Apparatus

BENCH CASTINGS, CONDENSERS,

Scrubbers, Purifiers, Dry Center Seals,

FOUR-WAY VALVES, GAS VALVES,

SULPHATE OF AMMONIA APPARATUS, TANKS, ENGINES, BOILERS, PUMPS, ETC., ETC.

Plans, Specifications and Estimates furnished for new works, or alteration of old works. Correspondence solicited. Works, Newport News, Va.

EDGEWATER LIME WORKS

Chas. F. McKenna, Proprietor.

SHELL LIME.

Lime by the Cargo for Gas Purification.

EDGEWATER, BERGEN CO., N. J.

Write for Testimonials and Prices.

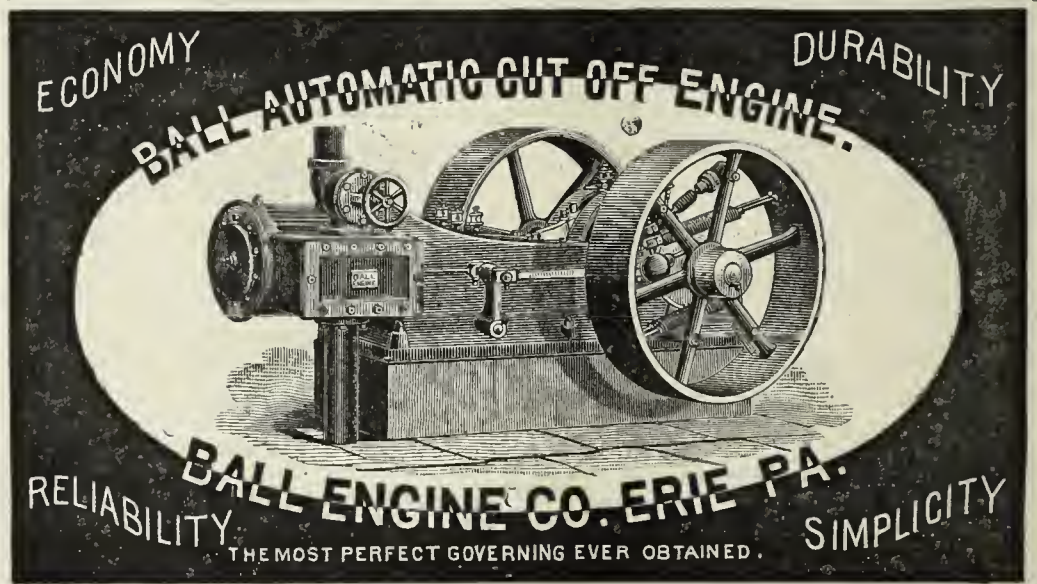

GASHOLDER PAINT.

Use Only

THE GOVERNMENT WATERPROOF PAINT.

Proof against Ammonia, and Absolutely Waterproof. Send for Prices and Particulars.

THE GOVERNMENT WATERPROOF PAINT CO., 122 Milk Street, Boston, Mass.

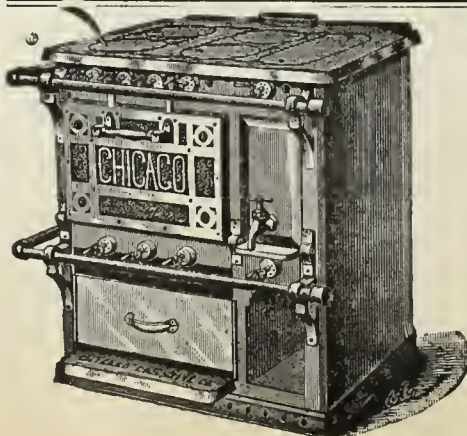

CHICAGO GAS STOVE CO.

MANUFACTURERS OF ALL KINDS OF

Gas Cooking and Heating APPLIANCES.

117-119 Lake St., CHICAGO.

Send for Catalogue.

The Gordon Portico Lamp.

A successful Competitor of the Arc Electric Light for lighting Store Fronts, Show Windows, Depots, Railway Sheds, etc., etc.

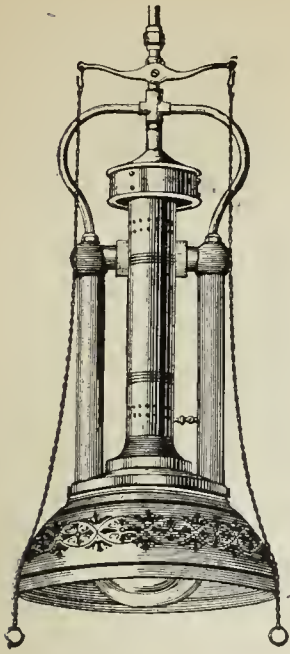

Gordon Portico Lamp.

The Gordon Street Lamp.

A Successful Competitor of the Arc Electric Light for lighting Streets, etc., etc.

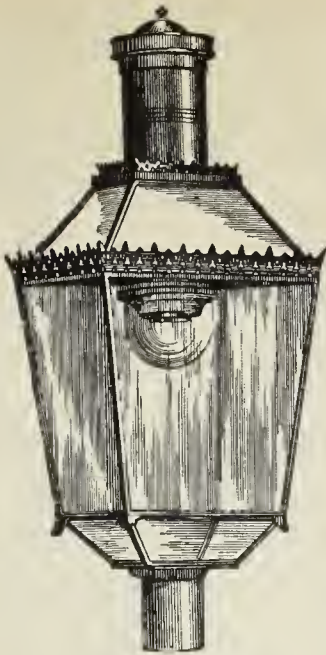

Gordon Street Lamp.

The Lungren Lamp.

A Successful Competitor of the Incandescent Electric Light for Interiors, etc. Is especially applicable for the lighting of Offices, Stores, Factories, Mills, Show Windows, Libraries, and all situations where an increased illumination is desired.

More than 25,000 Lungren Lamps are now in use. Testimonials, references, or any desired information will be cheerfully given.

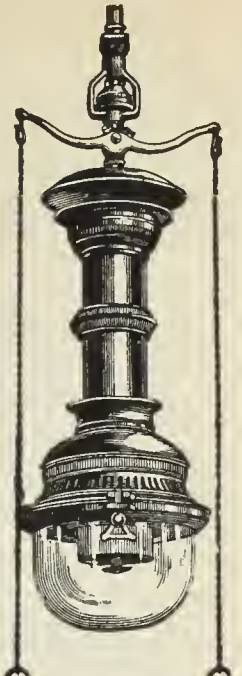

Lungren Lamp.

THE SIEMENS-LUNGREN CO., N.E. Cor. 21st St. & Washington Av., PHILADELPHIA.

WELSBACH SYSTEM OF Incandescent Gas Lighting.

OFFICE, DREXEL BUILDING, PHILA., PA.

At the Fall Session of the Board of Supervisors of Winnebago County, held at the County Court House, Oshkosh, Wis., Nov. 26, 1889, the report submitted by Mr. C. W. Cook, Chairman of the Committee on Public Buildings, recommending the use of the Welsbach Incandescent Gas Burner in the Buildings under their charge, was unanimously adopted, because of the extreme economy in the consumption of Gas and the superior character of the light obtained.

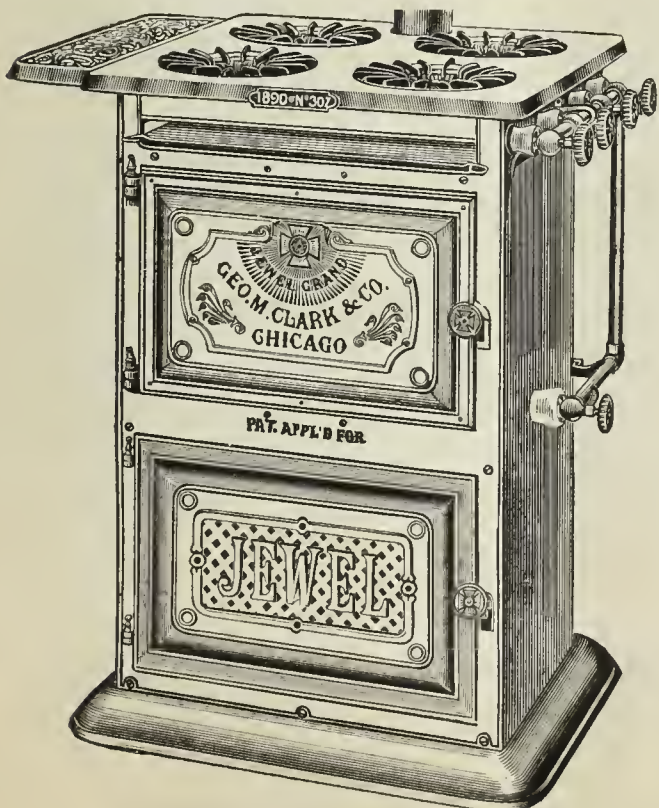

JEWEL GAS STOVES

MANUFACTURED BY

GEORGE M. CLARK & COMPANY,

Nos. 157 & 159 Superior Street, - - - Chicago, Ill.

EVERY CONCEIVABLE SIZE AND STYLE,

Ranging in Prices from \$1.50 to \$30.00.

WE USE NO GAS COCKS.

All Flames are Regulated by a Direct Needle Valve.

The JEWEL

IS THE

Only Well-Made Gas Stove on the Market.

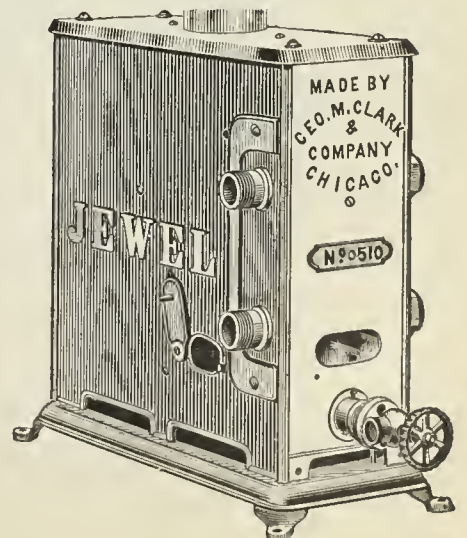

Jewel Circulating Water Heater.

Write for our 1890 Catalogue and see for yourself.

NATIONAL GAS LIGHT AND FUEL CO.,

218 La Salle Street, Chicago.

C. D. HAUK, Prest. & Gen'l Manager.

A. W. GREEN, Vice-Prest.

N. A. McCLARY, Sec. & Treas.

E. E. MORRELL, Engr.

GAS WORKS

Built, Remodeled, Leased, and Purchased.

71 Springer Cupolas
have been installed
in the U. S. during
the past four years.

The total capacity of
Springer Apparatus
now in use is over
25,000,000 ft. daily.

THE SPRINGER CUPOLA SYSTEM

Has Proven Itself the most Economical and Satisfactory Method of Gas Manufacture ever brought to the attention of the Gas Fraternity.

GUARANTEED ESTIMATES of Cost of Gas Furnished on Application.

GASHOLDER TANK CONSTRUCTION, ETC.

Gas Companies and others about to erect Gasholders will find it profitable to consult
W. C. Whyte, who for over 30 years has made a specialty of

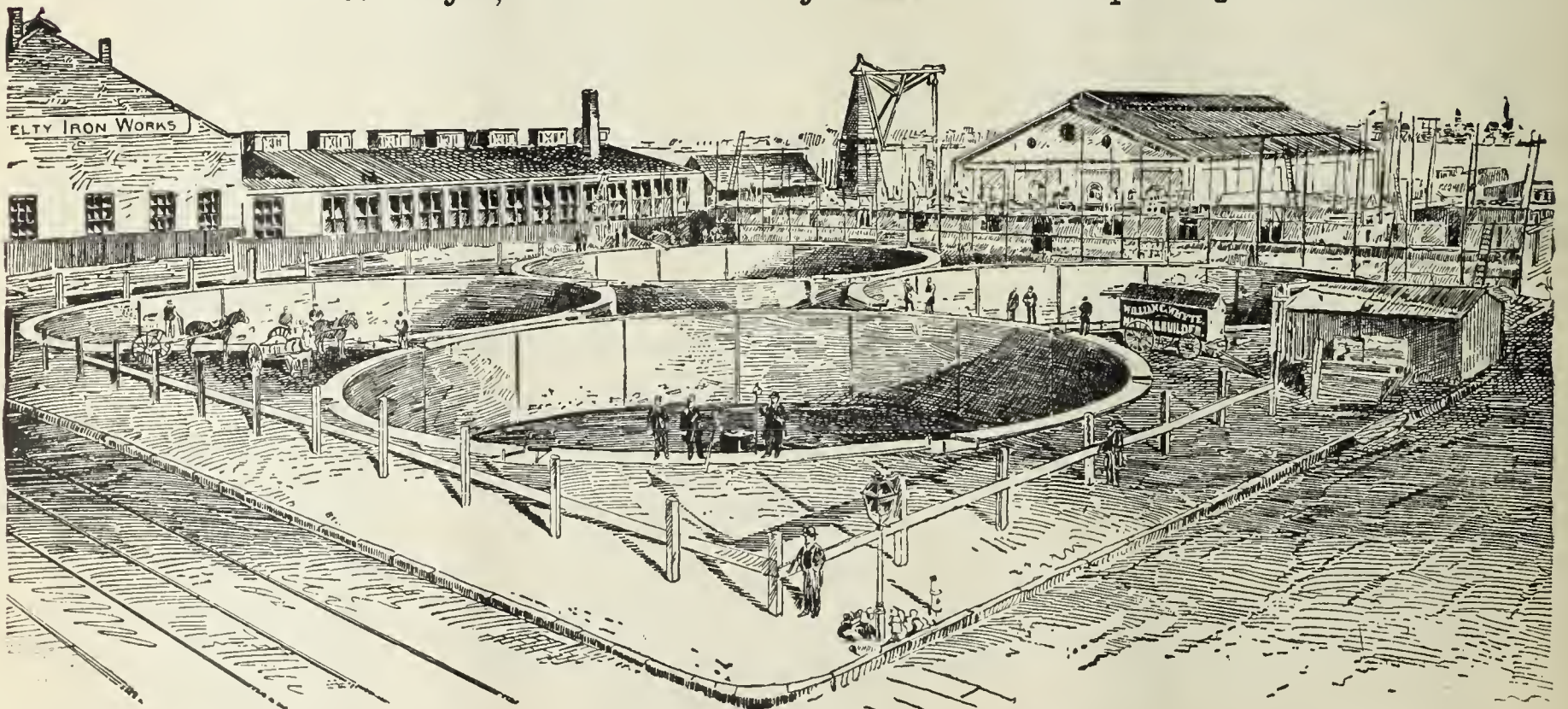

Tank Excavation and Mason Work.

Fifty Tanks now in operation show the sort of work done. Address

W. C. WHYTE, - No. 15 Cortlandt Street, N. Y. City

GAS STOVES.

GAS METERS.

GAS STOVES.

THE AMERICAN METER CO.

Established 1834.

Incorporated 1863.

MANUFACTURERS OF

Gas Meters,

STATION METERS,

METER PROVERS, PHOTOMETERS,

Pressure Gauges of all Kinds,



Standard 3 Diaphragm Dry Meter.

AND

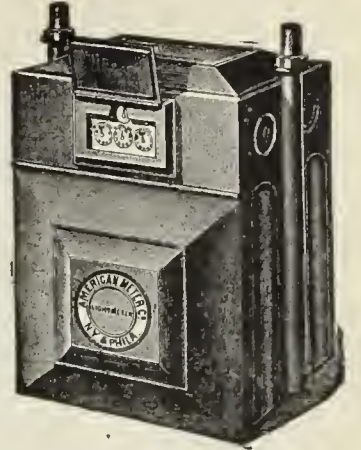

Standard 2 Diaphragm Dry Meter.

Apparatus for Testing the Quantity and Quality of Gases.

GAS STOVES FOR HEATING AND COOKING.



Circulars and Price Lists on Application.

MANUFACTORIES,

508 to 514 West Twenty-second St., N. Y.

Arch and Twenty-second St., Phila.

Nos. 244 & 246 North Wells Street, Chicago, Ill.

AGENCIES,

No. 177 Elm Street, Cincinnati, Ohio.

No. 222 Sutter Street, San Francisco, Cal.

No. 810 North Second Street, St. Louis, Mo.

GAS STOVE SHOW ROOMS, No. 242 Sixth Avenue, New York City.

KIRKHAM, HULETT & CHANDLER, LIMITED.

PATENT "STANDARD" WASHER-SCRUBBERS

Erected and in course of construction at present date:

Capacity. Cubic feet per day.	Capacity. Cubic feet per day.	Capacity. Cubic feet per day.	Capacity. Cubic feet per day.
Altrincham..... 600,000	Dublin..... 3,000,000	LONDON—Continued.	Ober Schlesian..... 1,500,000
Adelaide..... 600,000	Dowlais..... 100,000	Shoreditch..... 2,500,000	Otto & Co.'s Coke Works.... 1,500,000
Aldershot..... 200,000	Douai..... 500,000	Pancras..... 1,500,000	Plymouth..... 2,000,000
Allegheny, U. S. A. 1,000,000	Denton..... 500,000	"..... 1,500,000	Parramatta, N. S. W..... 100,000
Ashton-under-Lyne..... 1,250,000	Derby, U.S.A. 350,000	Pimlico..... 2,000,000	Prescott..... 150,000
Amsterdam..... 1,500,000	Denver, " 500,000	Nine Elms..... 3,000,000	Providence, U.S.A. 750,000
"..... 1,500,000	"..... 1,000,000	"..... 3,000,000	"..... 750,000
Annaberg..... 200,000	Dusseldorf..... 750,000		Plauen..... 300,000
Arcachon..... 100,000	"..... 500,000	South Metropolitan Co:—	"..... 300,000
Animal Charcoal Co..... 200,000	Dumfries..... 250,000		Portsmouth..... 2,500,000
Altoona, U.S.A. 350,000	Dunedin, N.Z..... 400,000	Greenwich..... 3,000,000	"..... 2,500,000
Buxton..... 250,000	Darlington..... 1,250,000	Woolwich..... 400,000	Pittsburgh, U.S.A. 1,500,000
Bradford..... 1,000,000	Detroit, U.S.A. 750,000	Vauxhall..... 3,000,000	Portland, " 560,000
"..... 1,250,000	Edinburgh..... 1,500,000	"..... 3,000,000	Pawtucket, " 500,000
"..... 1,250,000	"..... 2,000,000	"..... 3,000,000	Quebec 250,000
"..... 1,250,000	Enfield..... 300,000	Lea Bridge..... 300,000	Radcliffe..... 750,000
"..... 1,000,000	Essen..... 300,000	West Ham..... 1,500,000	Rouen..... 250,000
"..... 1,000,000	Elbing..... 150,000	Leeds..... 2,000,000	Ramsgate..... 1,000,000
"..... 3,000,000	Falmouth..... 150,000	"..... 3,000,000	Reigate..... 200,000
Bremen..... 150,000	Frankfort..... 300,000	"..... 3,000,000	Richmond, U.S.A. 250,000
Baltimore, U.S.A. 1,000,000	Farnworth..... 400,000	"..... 3,000,000	Roxbury, " 500,000
"..... 1,000,000	Fenton..... 400,000	"..... 3,000,000	Runcorn Soap Co..... 20,000
"..... 1,000,000	Friedenshutte..... 500,000	"..... 2,000,000	Rockhampton, N. S. W..... 125,000
Salmain, N.S.W..... 125,000	Furth..... 400,000	Leominster..... 150,000	Richmond..... 1,500,000
Bishops Stortford..... 150,000	Freiburg..... 200,000	Leiden..... 560,000	Reading..... 2,000,000
Blackpool..... 400,000	Goole..... 250,000	"..... 600,000	Reichenbach..... 200,000
Brussels..... 1,250,000	Glossop..... 300,000	Liverpool..... 2,000,000	Salford..... 1,750,000
"..... 1,250,000	Guildford..... 300,000	"..... 2,000,000	"..... 1,750,000
"..... 750,000	Gloucester..... 1,250,000	"..... 2,000,000	"..... 1,750,000
"..... 1,250,000	Gera..... 300,000	"..... 2,000,000	Smethwick..... 750,000
Baubury..... 250,000	Grafton, N.S.W..... 100,000	"..... 2,000,000	Sydney, N. S. W..... 1,000,000
Birmingham..... 5,000,000	Grieg..... 300,000	"..... 3,000,000	"..... 1,000,000
Birkenhead..... 2,500,000	Georgetown, U.S.A. 250,000	Lincoln..... 1,000,000	"..... 2,500,000
Blackburn..... 1,500,000	Gluckauf..... 200,000	"..... 600,000	"..... 50,000
Bochum..... 600,000	Heywood..... 600,000	Lowell, U. S. A. 1,000,000	"..... 50,000
Burntisland..... 250,000	Hollywood..... 125,000	Louisville " 1,500,000	Sunderland..... 1,500,000
Boston, U.S.A. 2,000,000	Huy..... 70,000	Long Eaton..... 500,000	St. Josephs, U.S A 250,000
Brisbane..... 1,500,000	Harrow..... 250,000	Lilie..... 900,000	Spa..... 100,000
"..... 300,000	Harrogate..... 250,000	"..... 450,000	Sevenoaks..... 300,000
Burton-on-Trent..... 1,500,000	Halstead..... 150,000	"..... 750,000	St. Petersburg..... 2,000,000
Barcelona..... 350,000	Heilbronn..... 200,000	"..... 250,000	"..... 1,500,000
Barking..... 100,000	Havana, Cuba 750,000	"..... 250,000	St. Louis, U.S.A. 2,000,000
Baerlien & Co..... 20,000	Hastings..... 1,500,000	Luckenwalde..... 330,000	"..... 2,000,000
"..... 20,000	Huddersfield..... 300,000	Liegwitz..... 300,000	"..... 1,000,000
Bombay..... 400,000	"..... 750,000	Lincoln, U. S. A. 250,000	Laclede 1,000,000
Buffalo, U.S.A., Mutual 750,000	"..... 1,500,000	Lawrence " 500,000	Silesian Coal Co..... 600,000
"..... Citizen 500,000	Hof..... 200,000	Lynn " 300,000	San Francisco, U.S.A. 2,000,000
Brookline, U.S.A. 500,000	Hampton Wick..... 500,000	Lyons..... 1,500,000	"..... 2,000,000
Bergen..... 350,000	Heckmondwicke..... 500,000	Maidstone..... 1,000,000	Sheepbridge Coal Co..... 40,000
Berlin..... 1,250,000	Haverfordwest..... 100,000	Marseilles..... 1,500,000	Stettin..... 200,000
Bournemouth..... 1,000,000	Halifax, N.S. 350,000	"..... 1,500,000	Singapore..... 300,000
Bridgeport, U.S.A. 500,000	Hamm..... 200,000	Mons..... 500,000	Sutton..... 500,000
Brunswick..... 300,000	Halle..... 400,000	Malines..... 250,000	Tonbridge..... 150,000
Beck & Co., St. Louis 100,000	Heidelberg..... 300,000	Melbourne..... 1,500,000	Tipton..... 400,000
Barmen Rittershausen..... 600,000	Hartford, U.S.A. 1,000,000	"..... 1,500,000	Tottenham..... 1,000,000
Bexhill..... 125,000	Ilkeston..... 300,000	"..... 1,500,000	Toledo, U.S.A. 750,000
Brooklyn, U.S.A. 1,000,000	Inverness..... 2,000,000	"..... 1,500,000	Toronto 1,000,000
"..... Nassau 1,000,000	Ilkley..... 200,000	"..... 1,500,000	Uxbridge..... 300,000
Brunner, Mond & Co..... 400,000	Ilford..... 100,000	Manchester..... 2,500,000	Valparaiso 500,000
Cheltenham..... 2,000,000	Kingston-on-Hull..... 400,000	Middleton..... 400,000	West Bromwich..... 1,000,000
Cannes..... 200,000	Kidderminster..... 750,000	Manley, N. S. W..... 100,000	Willenhall..... 250,000
Croydon..... 1,500,000	Kidsgrove..... 100,000	Minneapolis, U. S. A. 750,000	Weston-super-Mare..... 500,000
Copenhagen..... 200,000	Konigsberg..... 1,000,000	Magdeburg..... 300,000	Waltham..... 150,000
Clevedon..... 200,000	King's Lynn..... 300,000	Memphis, U. S. A. 750,000	Wormwood Scrubs..... 300,000
Columbus, U.S.A. 500,000	LONDON:—	Nottingham..... 1,250,000	Williamsburg, U.S.A. 600,000
Cincinnati, " 1,500,000	The Gaslight and Coke Co.:	"..... 2,500,000	Wellington..... 150,000
"..... 1,500,000	Beckton..... 1,250,000	"..... 2,500,000	Warwick..... 300,000
Chicago 3,000,000	"..... 1,250,000	"..... 2,000,000	Wheeling, U.S.A. 500,000
"..... 1,000,000	"..... 1,250,000	"..... 1,500,000	Walker..... 300,000
"..... 1,000,000	"..... 1,250,000	"..... 2,000,000	Westgate..... 100,000
Chemnitz..... 1,000,000	"..... 1,250,000	Newport, U.S.A. 430,000	Wilmington, U.S.A. 500,000
Crewe..... 1,250,000	"..... 1,250,000	Newmarket..... 150,000	Windsor, N. S. W..... 100,000
Colonial Gas Works Co..... 100,000	"..... 1,250,000	Newark, U.S.A. 680,000	Wolverton..... 100,000
Cadiz..... 300,000	"..... 1,250,000	Northfleet..... 200,000	Wellington, N. Z..... 250,000
Charlottenburg..... 600,000	"..... 2,500,000	New York, U.S.A. 2,000,000	Whitchurch..... 175,000
Dudley..... 750,000	"..... 2,500,000	Nice..... 600,000	Washington, U.S.A. 2,000,000
Driffield..... 100,000	Silvertown..... 1,000,000	Newcastle, N. S. W..... 200,000	Wallasey..... 750,000
Dukenfield..... 500,000	Bromley..... 2,000,000	Numea, "..... 100,000	Weimar..... 150,000
Dover..... 750,000	"..... 1,500,000	Namur..... 250,000	Wurzen..... 200,000
"..... 750,000	"..... 1,500,000	Newark..... 350,000	Worcester, U.S.A. 750,000
"..... 1,000,000	"..... 1,500,000	Oldbury..... 500,000	Yeafon..... 500,000
Deal..... 200,000	"..... 2,000,000	Otley..... 200,000	Yeovil..... 250,000
Deby..... 1,500,000	"..... 1,500,000	Oswestry..... 250,000	

SOLE AGENT FOR WESTERN HEMISPHERE,
GEO. SHEPARD PAGE, 69 WALL STREET, NEW YORK

THE UNITED GAS IMPROVEMENT CO.

Drexel Building,

CHESTNUT AND FIFTH STREETS,

PHILADELPHIA, PA.

OFFICERS:

WILLIAM W. GIBBS, President.

GEORGE PHILLER, Vice-President.

SAM'L T. BODINE, Gen'l Manager.

RANDAL MORGAN, Gen'l Counsel.

EDWARD C. LEE, Sec'y and Treas.

ALEX. C. HUMPHREYS, Gen'l Supt.

WALTON CLARK, Ass't Gen'l Supt.

H. H. EDGERTON, Chem. and Eng'r.

DIRECTORS:

GEORGE PHILLER,

THOMAS DOLAN,

HENRY C. GIBSON,

WM. T. CARTER,

WILLIAM G. WARDEN,

SAM'L T. BODINE.

BUILDERS, LESSEES AND PURCHASERS OF

✻ GAS WORKS. ✻

ROOTS' GAS AND BYE-PASS VALVES.

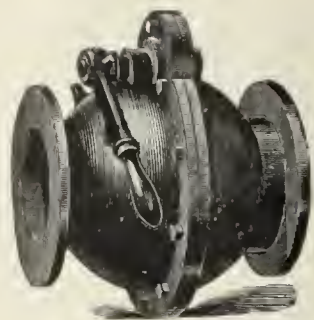

GAS VALVE

Quick Acting,
Simple,
Efficient, Durable.

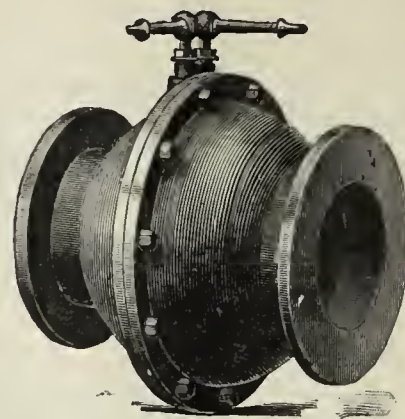

BYE-PASS VALVE.

Automatic Action
Reliable
Simple Durable.

Thousands now in use and giving perfect satisfaction. Write for Catalogue and Prices.

ROOTS' NEW GAS EXHAUSTER.

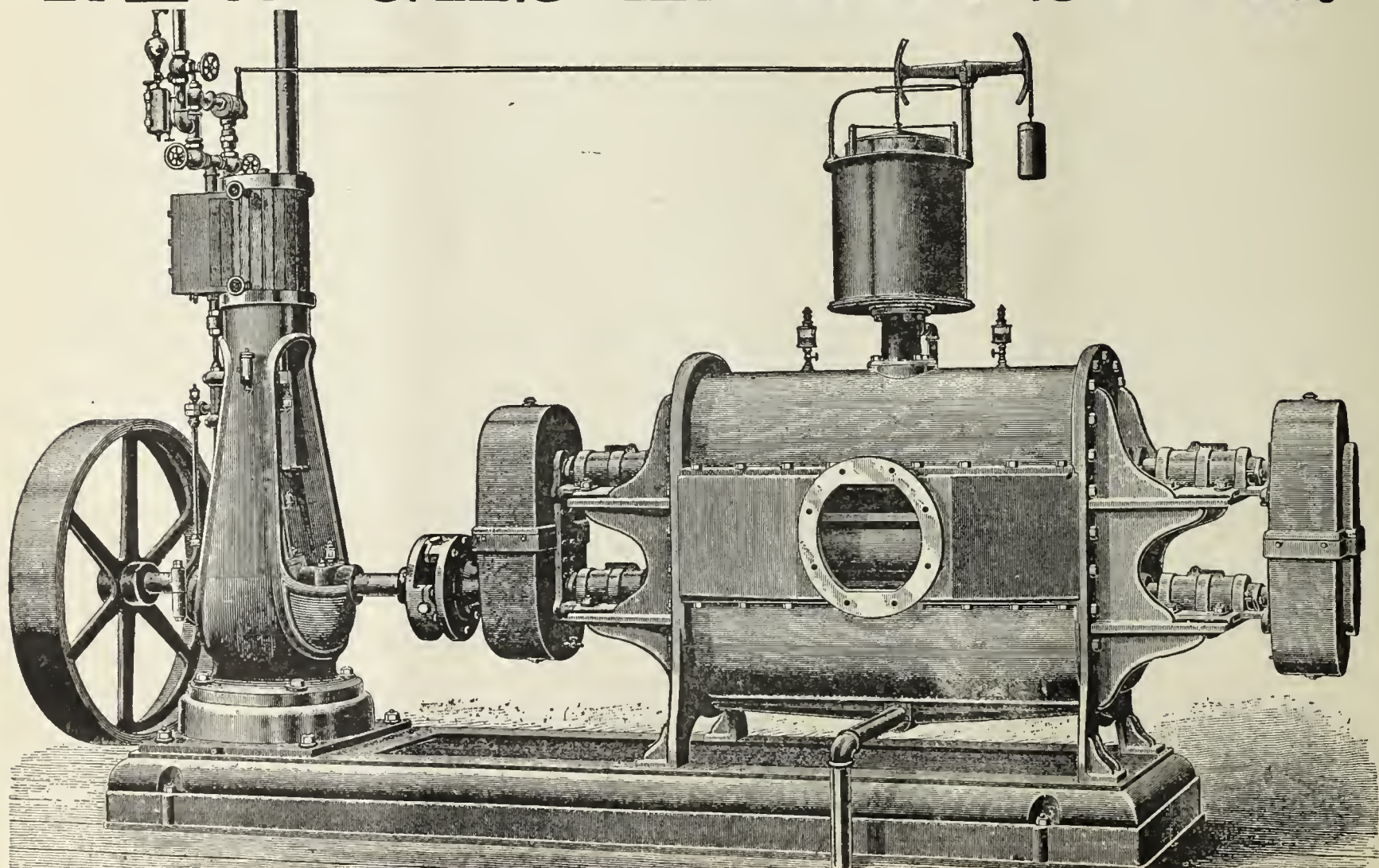

THE P. H. & F. M. ROOTS CO., Patentees and Manufacturers, CONNERSVILLE, IND.
S. S. TOWNSEND, Gen. Agt., 22 Cortlandt St., N. Y. COOKE & CO., Selling Agts., 22 Cortlanat St., N. Y.

CONNELLY & CO.,

SOLE MANUFACTURERS OF THEIR PATENTED SPECIALTIES.

"IRON SPONGE."

Saves money, saves labor, and is the most efficient purifying agent ever offered as a substitute for lime. Now used in every State in the Union, and purifying daily over thirty-five million cubic feet. Should be used in every gas works. Its own saving will pay for it many times over.

AUTOMATIC GOVERNOR.

Has been on the market but three years, and in that time has been introduced more generally than any invention ever designed for use in gas works. Over two hundred of them now in use. Sensitive; reliable; perfectly automatic; reduces leakage; satisfies consumers, and gives great relief to the Manager. No gas works is complete without one of these machines.

STEAM JET EXHAUSTER.

Designed particularly for small works. Combines Exhaust Tube, Steam Governor Gas Compensator, and Bye-Pass Valves in the most compact form possible; occupies but little space; uses very little steam; operated by ordinary workmen; saves formation of carbon in retorts; increases yield 10 to 15 per cent. Specially adapted for mixing air with oil gas. No works too small to use them profitably.

Prices given on all our specialties delivered at any point in the United States. Correspondence solicited.

CONNELLY & CO., No. 111 Broadway, New York City.

WILBRAHAM GAS EXHAUSTER

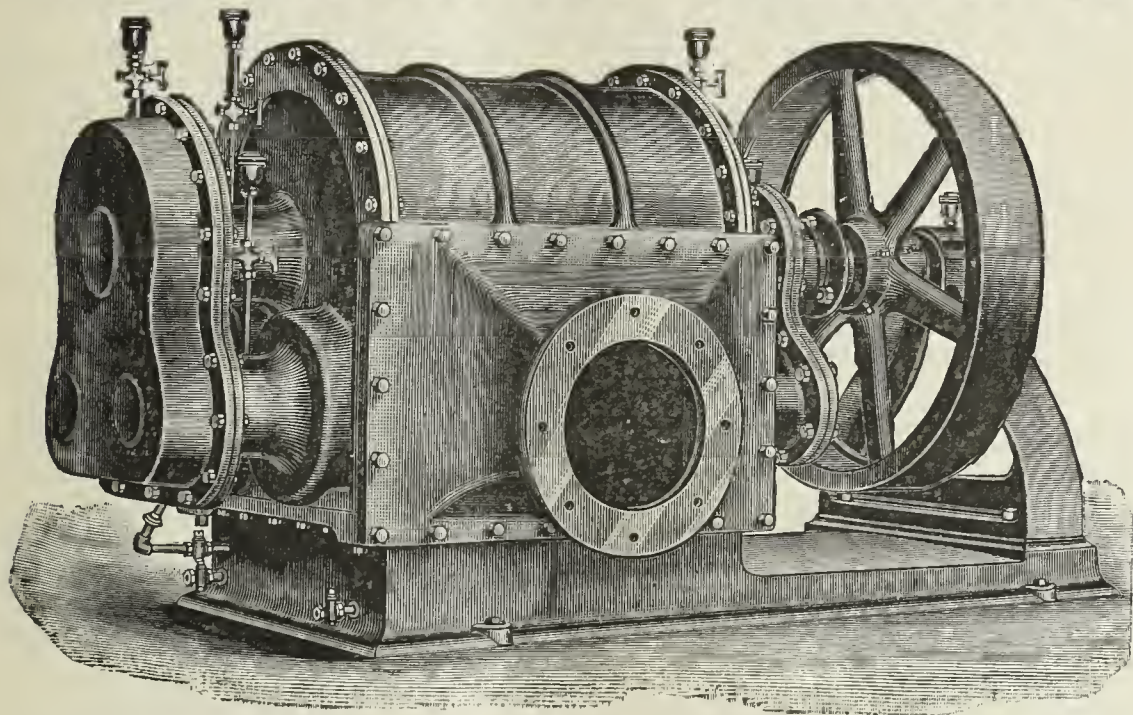

WILBRAHAM BROS.,
PHILADELPHIA, PA.

JARVIS ENGINEERING CO.,

61 Oliver St., Boston, Mass.

CONTRACTORS FOR ERECTING

COMPLETE STEAM OUTFITS FOR ELECTRIC LIGHTING STATIONS.

Steel Boilers set with Jarvis Pat. Boiler Setting

To burn COKE SCREENINGS for Fuel.

ARMINGTON & SIMS CO. ENGINES,

Belting direct to Dynamos, without using Shafting.

SEND FOR CIRCULARS.

REFERENCES.—Charlestown Gas & Electric Light Co., Charlestown, Mass.; Schenectady Gas & Electric Light Co., Schenectady N. Y.; Brookline Gas Co., Brookline, Mass.

Practical Electric Lighting

By A. BROMLEY HOLMES, A.M.I.C.E.

With 87 Illustrations. Third Edition. Price, \$1.00.

Electric Light Primer.

By CHARLES L. LEVEY.

A simple and comprehensive Digest of all the most important facts connected with the running of the Dynamo and Electric Lights, with Precautions for Safety, etc.

Price, 50 cents.

A. M. CALLENDER & CO., 42 Pine St., N. Y.

Gasholder Tanks & Gas Works Masonry Complete.

PLANS PREPARED AND ESTIMATES FURNISHED AT SHORT NOTICE.

J. P. WHITTIER, - - 499 Wythe Av., Brooklyn, N. Y.

1890 DIRECTORY 1890

OF THE GAS LIGHT COMPANIES of the UNITED STATES & CANADA.

Price, \$5.00.

A. M. CALLENDER & CO., No. 42 Pine Street, N. Y. City.



CHAPMAN VALVE MANUFACTURING CO.,

MANUFACTURERS OF

Valves and Gates for Gas, Ammonia, Water, Etc.

Also, Gate Fire Hydrants With and Without Independent Nozzle Valve. All Work Guaranteed.

WORKS & GEN'L OFFICE:
Indian Orchard, Mass.

TREASURER'S OFFICE:
72 Kilby & 112 Milk Sts, Boston, Mass.

LUDLOW VALVE MFG. CO.



OFFICE AND WORKS,

33 to 954 River Street and 67 to 83 Vail Av.
TROY, N. Y.

Parson's Steam Blower,

FOR IMPROVING BAD DRAUGHT IN BOILERS, AND FOR BURNING BREEZE OR OTHER WASTE MATERIAL.

PARSON'S TAR BURNER,

FOR UTILIZING COAL TAR AS FUEL.

PARSON'S AIR JET TUBE CLEANER,

FOR CLEANING BOILER TUBES.

These devices are all first-class. They will be sent to any responsible party for trial. No sale unless satisfactory. Manufactured by the WATERTOWN STEAM BLOWER COMPANY.

H. E. PARSON, Supt., 33 & 35 Liberty St., N. Y

MILLS' REVERSIBLE LIME TRAY,

AND

WOODWORK

Of Every Description

NEEDED BY GAS WORKS.

SEND FOR CIRCULAR AND PRICE LIST TO

BARTLETT, HAYWARD & CO.,

Pratt and Scott Streets, Baltimore, Md.

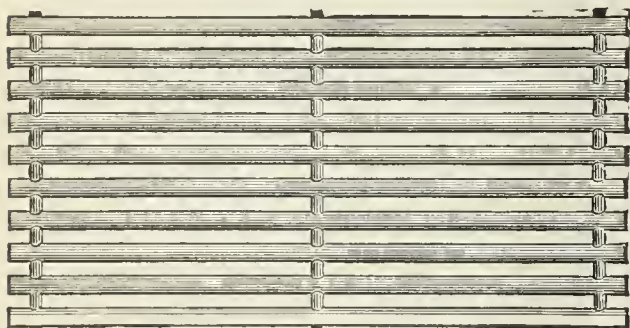

VAN DUZEN GAS & GASOLINE ENGINE

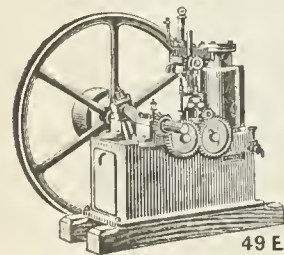

OPERATED WITH COAL and OTHER MANUFACTURED GASES AND GASOLINE.

RELIABLE AND ECONOMICAL.

Fully Warranted

VAN DUZEN

Gas & Gasoline Engine Co.

49 E. 2d St., Cincinnati, O.

A. MacKinnon Machine Co., Agts., 22 Warren St., N. Y.

The Management of Small Gas Works.

BY C. J. R. HUMPHREYS.

Price, \$1.

Orders to be sent to **A. M. CALLENDER & CO.,**

42 PINE STREET, NEW YORK.

Hydraulic Main Dip Regulators, Check Valves, Foot Valves, Yard wash and Fire Hydrants. Send for Circulars.

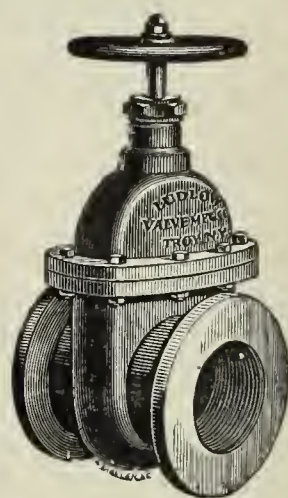

Valves.—Double and Single Gate, 1/2 in. to 48 in., outside and inside Screws. Indicator, etc., for Gas, Water, Steam, and Oil. Send for Circulars.

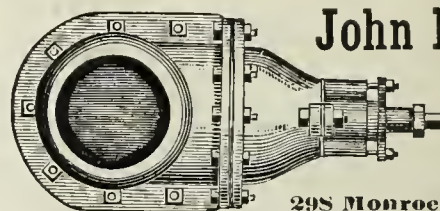

John McLean

Man'facturer

GAS VALVES.

298 Monroe Street, N. Y.

SPECIAL TRAYS FOR IRON SPONGE OR OXIDE OF IRON. CHURCH'S TRAYS A SPECIALTY.

REVERSIBLE—STRONGEST—MOST DURABLE—MOST EASILY REPAIRED.

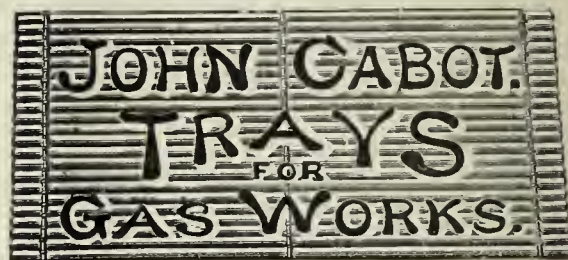

306-310 ELEVENTH AVENUE, NEW YORK.

WE ALSO MAKE THE CHEAPEST AND STRONGEST REVERSIBLE BOLTED TRAYS IN THE MARKET.

THE CLERK GAS ENGINE CO.,

Main Office, 1012, 1014, 1016, 1018 Filbert St., Philadelphia, Pa.

WM. W. GOODWIN, Prest.

E. STEIN, Sec.

S. LEWIS JONES, Asst. Sec.

A. J. DOTY, Supt.

The utility and convenience of the Gas Engine being no longer an open question, it only remains now for intending purchasers to select the BEST. We claim for the CLERK GAS ENGINE that it is equal to any other manufactured as regards steadiness in running, simplicity, and ease of keeping in repair, and that it gives the greatest amount of power for the least money (both in first cost and expense of running) of any engine made. In support of this claim we refer to the test of the Gas Engines made under the direction of the American Institute of New York, in December, 1885, and heretofore published in these columns. These engines are especially adapted for continuous running under heavy loads, and we can refer to Engines which have run 22 hours a day for months at a time

Made in Sizes of 5, 10, 15, 20, and 25 Horse Power. All Engines Guaranteed for One Year.

ENGINEERS.

P. D. WANNER, Chairman. A. H. MELLERT, Mangr. of Wks.
R. B. KINSEY, Secretary. F. A. KNOPP, Treasurer.

MELLERT FOUNDRY & MACHINE CO. Ltd.
and **READING FOUNDRY CO., Ltd.**
Reading, Pa.

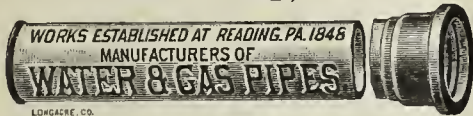

Specials—Flange Pipe, Valves and Hydrants,
Lamp Posts, Retorts, etc.

General Foundry and Machine Work.
JOHN FOX, Selling Agent. 160 Broadway, N. Y.

THE OHIO PIPE COMPANY,

MANUFACTURERS OF

Cast Iron Gas & Water Pipe,

BRANCH AND SPECIAL CASTINGS.

Gas-House Bench Castings, Hydraulics, Lamp Posts, Flange Pipe
and Specials, Architectural Castings, Building Columns,
Joists, Cellar Grates, Sash Weights, etc.

GENERAL FOUNDERS AND MACHINISTS.
Columbus, Ohio.

M. J. DRUMMOND,



SPECIAL CASTINGS AND LAMP POSTS.
Office, Corbin Building, 192 Broadway, N. Y.

EMAUS PIPE FOUNDRY.

DONALDSON IRON COMPANY. EMAUS, PA.



MANUFACTURERS OF

CAST IRON PIPE AND SPECIAL CASTINGS
FOR WATER AND GAS.

JOS. R. THOMAS,

No. 42 Pine Street, N. Y. City.

CONSULTING AND CONSTRUCTING
Gas Engineer and Contractor.

PLANS, SPECIFICATIONS, AND ESTIMATES
FURNISHED.

Contracts taken for all Appliances
required at a Gas Works,
Either for New Works or Extensions to Old Plants.

WM. MOONEY

(Successor to WM. FARMER)

No. 94 Liberty St., N. Y. City.

GAS ENGINEER AND CONTRACTOR FOR THE ERECTION
OF GAS WORKS, OR APPARATUS OF ANY
CAPACITY.

Plans and Specifications Furnished.

WM. GARDNER,
Gas Engineer,

Lewis Block, Room 20, Pittsburgh, Pa.

Those who intend to make alterations in existing gas plants, or
who contemplate the erection of new works, will find it to their
interest to open correspondence with the above. Plans made
and estimates furnished.

GAS AND WATER PIPES.

SAM'L R. SHIPLEY, Pres.
HENRY B. CHEW, Tre

GLOUCESTER IRON WORKS,
GLOUCESTER CITY, N. J.



JAS. P. MICHELON, Sec.
WM. SEXTON, Supt.

Cast Iron Gas & Water Pipes, Stop Valves, Fire Hydrants, Gasholders. &c.

Office, Rooms 61 and 63 Bullitt Building, 131 S. 4th St., Phila., Pa.

WARREN FOUNDRY AND MACHINE CO.,

Established 1856. Works at Phillipsburgh, N. J.

New York Office, 160 Broadway.

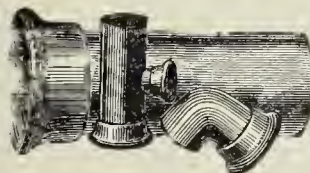

CAST IRON WATER AND GAS PIPE,

FROM TWO TO FORTY-EIGHT INCHES DIAMETER. ALSO, ALL SIZES OF

Flange Pipe for Sugar House and Mine Work. Branches, Bends, Retorts, etc., etc.

DENNIS LONG & COMPANY,

LOUISVILLE, KY.,



Manufacture Exclusively

CAST IRON GAS & WATER PIPE & SPECIAL CASTINGS
OF ALL SIZES.

King's Treatise on Coal Gas.

A standard text-book for the Engineers and Managers of Gas Works, and for all who are concerned
or take an interest in the manufacture and distribution of Coal Gas, and in the utilization of the
Secondary Products resulting therefrom; treating also of the Gas Engine, and of Gas Cooking and
Heating Appliances

In 3 Vols. Price per Vol., \$10. Sold either by Volume or in Sets.

A. M. CALLENDER & CO., 42 Pine St., N. Y.

RETORTS AND FIRE BRICK.

J. H. CAUTIER & CO.,

CORNER OF

GREENE AND ESSEX STREETS,

JERSEY CITY, N. J.

MANUFACTURERS OF

Clay Gas Retorts,**Gas House Tiles,****Fire Bricks, Etc. Etc.****Ground Clay, Fire Brick and****Fire Sand in Barrels,**

J. H. GAUTIER. C. E. GREGORY. C. E. GAUTIER.

BROOKLYN**Clay Retort & Fire Brick Works,**

(EDWARD D. WHITE & CO.)

Manufacturers of Clay Retorts, Fire Brick,
Gas House and other Tile.

VAN DYKE, ELIZABETH, RICHARDS & PARTITION STS.

Office, 88 Van Dyke St., Brooklyn, N. Y.

RETORTS AND FIRE BRICK.

LACLEDE FIRE BRICK MFG. CO.,

MANUFACTURERS OF

Fire Brick, Gas Retorts,

AND

ST. LOUIS STANDARD SEWER PIPE.Blast Furnace and Cupola Linings, every description of Fire
Clay Material, Fire Clay Flue Linings, Chimney Tops
Dry Milled and Crude Fire Clays, etc.

OFFICE AND DEPOT

901, 903, and 905 Pine Street,

ST. LOUIS, MO.

ESTABLISHED IN 1845.

B. KREISCHER & SONS,

OFFICE FOOT OF HOUSTON ST., E. R., N. Y.

Gas Retorts,**TILES, FIRE BRICK.**

AND EVERYTHING IN THE FIRE CLAY LINE.

RETORTS AND FIRE BRICK.

MANHATTAN

FIRE BRICK & ENAMELLED CLAY

RETORT WORKS**ADAM WEBER.****CLAY GAS RETORTS**

AND RETORT SETTINGS

FIRE BRICKS, TILES, ETC.,

Office and Works, 15th Street and Avenue C., N. Y.



Works,

LOCKPORT STATION, PA.

—ESTABLISHED 1864.—

JAMES GARDNER, JR.,

Successor to WILLIAM GARDNER & SON.

Fire Clay Goods for Gas Works.

H. A. NORTON, No. 4 CENTRAL STREET, BOSTON, MASS., Agent for the New England States.

GEO. C. HICKS,
Prest.**CHICAGO**CHAS. A. REED,
Sec. & Treas.**Retort and Fire Brick Co.,**

MANUFACTURERS OF

Fire Clay Goods of all Kinds,

AND BEST QUALITY ONLY.

Regenerative Furnaces & Water Gas Goods.

45th St., Clark to La Salle, Chicago.

GEROULD'S IMPROVED RETORT CEMENT.A Cement for patching retorts, putting on mouthpieces, and
making up all bench-work joints. This Cement is mixed ready
or use. Economic and thorough in its work. Fully warranted
o stick. For recommendations and price list address**C. L. GEROULD & CO.,**

5 & 7 Skillman St., Brooklyn, N. Y.

Western Agent, H. T. GEROULD, Mendota, Ill.

**Parker-Russell
Mining and Mfg. Co.,**

CITY OFFICE,

Mermod-Jaccard Bldg., Rooms 307 & 308,
Broadway & Locust St., St. Louis, Mo.

PROPRIETORS OF THE

OAKHILL GAS RETORT & FIRE BRICK W'KSOur immense establishment is now employed almost entirely in
the manufacture of**Materials for Gas Companies**We have studied and perfected three important points. Our re-
torts are made to stand changes of temperature, the strongest
heats of the furnace, and the abrasion of feeding and emptying.
We have the exclusive Agency for the West of the celebrated**Kloenne-Bredel Full Depth and
Semi-Recuperator Benches,**

And also furnish and build

**Our Own Styles Semi-Recuperator Furnaces
for the use of Coal or Coke as fuel.**

THOS. SMITH, Prest.

AUGUST LAMBLA, Vice-Prest. & Supt.

BALTIMORE**RETORT & FIRE BRICK CO.**

MANUFACTORY AT

LOCUST POINT, BALTIMORE, MD.

Clay Retorts, Blocks & Tiles**FIRE BRICK, FIRE CLAY,****AND FIRE CEMENT.****Red and Buff Ornamental Tiles and Chim-
ney Tops. Drain and Sewer Pipe (from
2 to 30 inches). Baker Oven Tiles
12 x 12 x 2 and 10 x 10 x 2.**

WALDO BROS., 88 WATER ST., BOSTON, MASS

Sole Agents the New England States.

Boston Fire Brick Works Manufacturers of **Gas Retorts and Settings**

Under the Personal Supervision of MR. GEO. C. HICKS late of Chicago.

Fire Clay Goods of all kinds. Akron Sewer Pipe, Lime, Cement, etc. Agts. for the Arc Gas Lamp & Governing Gas Burners.

Send for Circulars and Prices to

FISKE, COLEMAN & CO., Managers, No. 62 Congress Street, Boston, Mass.

HENRY MAURER & SON,

(ESTABLISHED 1856.)

**EXCELSIOR FIRE BRICK & CLAY
RETORT WORKS**

WORKS, Perth Amboy, N. J.

OFFICE, 418 to 422 East 23d St., N. Y.

**Clay Gas Retorts,
BENCH SETTINGS,
Fire Brick, Tiles, Etc.**

**FLEMMING'S
Generator-Gas Furnace**

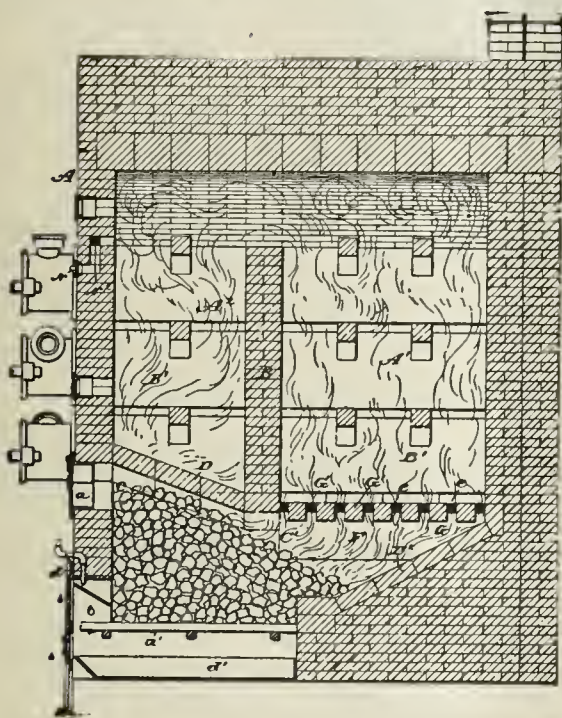

Materials furnished and Benches erected by

J. H. GAUTIER & CO., - Jersey City, N. J.

Address as above, or D. D. FLEMMING, Jersey City, N. J.

FRED. BREDEL,

CONTRACTOR FOR THE COMPLETE

Erection and Equipment of Gas Works.

SOLE PROPRIETOR OF THE

KLOENNE PATENTS

FOR NORTH AMERICA.

REGENERATIVE FURNACES.

(900 Retorts are now fired in America by the Kloenne-Bredel System.)

SELF-SEALING MOUTHPIECES.

(Over 800 Now in Use.)

Standard Condensers. Washer-Scrubbers.

TAR WASHERS FOR WATER GAS PLANTS.

(In use in the works of the Chicago Gas Lt. Co.)

GASHOLDERS.

Bredel's Automatic Gas Governor.

Refers, by permission, to Mr. Eugene Vanderpool, Newark, N. J.; Mr. E. G. Cowdery, Milwaukee, Wis.; and Mr. Theo. Forstall, Chicago, Ills. For further information, address

FRED. BREDEL,

No. 208 East Seventeenth Street, N. Y. City.

SCIENTIFIC BOOKS.

- | | | |
|---|--|--|
| <p>KING'S TREATISE ON THE MANUFACTURE OF COAL GAS. Three vols.; \$10 per vol.</p> <p>GAS MANUFACTURE, by WILLIAM RICHARDS. 4to., with numerous Engravings and Plates, in Cloth binding. \$12.</p> <p>TECHNICAL GAS ANALYSIS. \$2.80.</p> <p>GAS CONSUMER'S GUIDE. \$1.</p> <p>A GUIDE TO GAS LIGHTING. 40 cents.</p> <p>GAS MEASUREMENT AND GAS METER TESTING, by F. W. HARTLEY. \$1.60</p> <p>GAS CONSUMER'S HANDBOOK, by WILLIAM RICHARDS, C.E.; 18mo., Sewed. 20 cents.</p> <p>A PRACTICAL TREATISE ON GAS AND VENTILATION with Special Relation to Illuminating, Heating, and Cooking Gas, by E. E. PERKINS. \$1.25.</p> <p>PRACTICAL TREATISE ON HEAT, by THOMAS BOX. Second edition. \$5.</p> | <p>GAS WORKS—THEIR ARRANGEMENT, CONSTRUCTION, PLANT, AND MACHINERY. \$8.</p> <p>COAL; ITS HISTORY AND USE, by PROF. THORPE. \$3.50.</p> <p>THE GAS WORKS OF LONDON, by COLBURN. 60 cents.</p> <p>THE GAS FITTER'S GUIDE, Showing the Principles and Practice of Lighting with Coal Gas, by JOHN ELDRIDGE. 40 cents.</p> <p>GAS WORKS, AND MANUFACTURING COAL GAS, HUGHES. \$2.20.</p> <p>THE MANAGEMENT OF SMALL GAS WORKS, by C. J. R. BUMPHEYS. \$1.</p> <p>MANUAL FOR GAS ENGINEERING STUDENTS, by D. LEE, 40 cents.</p> <p>HOW TO MANAGE GAS, by F. WILKINS. Paper. 20 cents.</p> <p>THE DOMESTIC USES OF COAL GAS, AS APPLIED TO LIGHTING, by W. SUGG. \$1.40.</p> <p>DIGEST OF GAS LAW. \$5.</p> | <p>DISTILLATION OF COAL TAR AND AMMONIACAL LIQUOR, by GEO. LUNGE. New Edition. \$12.50.</p> <p>A TREATISE ON THE COMPARATIVE COMMERCIAL VALUES OF GAS COALS AND CANNELS, by D. A. GRAHAM 8vo., Cloth. \$3.</p> <p>GAS COMPANIES DIRECTORY. \$3.</p> <p>GAS VERSUS ELECTRIC LIGHT. 50 cents.</p> <p>THE AMERICAN GAS ENGINEER AND SUPERINTENDENT'S HANDBOOK, by WM. MOONEY. \$3.</p> <p>GAS ENGINE INDICATOR DIAGRAM, by W. E. AYRTON. Paper. 20 cents.</p> <p>ILLUMINATING AND HEATING GAS, by W. BURNS. \$1.50.</p> <p>TESTING PIPES AND PIPE JOINTS, by M. M. PATERSON. 80 cents.</p> <p>DESIGNING WROUGHT AND CAST IRON WORK, by H. ADAMS. Paper. Three parts, 60 cents each.</p> <p>NOTES IN MECHANICAL ENGINEERING, by H. ADAMS. \$1.</p> <p>STRAINS IN IRONWORK, by H. ADAMS. With plates. \$1.75.</p> |
|---|--|--|

The above will be forwarded by express, upon receipt of price. If sent by mail, postage must be added to above prices. We take especial pains in securing and forwarding any other Works that may be desired, upon receipt of order. All remittances should be made by check, draft, or post office money order.

A. M. CALLENDER & CO., 42 Pine Street, New York.

Newbigging's Handbook for Gas Engineers and Managers.

The present (the fifth) edition marks an important advance on those that have gone before. Considerable additions have been made to the text, and much of it has been re-written and otherwise improved. It extends to 524 pages, and contains 193 illustrations. **Price, Cloth, \$6.00.**

A. M. CALLENDER & CO., - - - No. 42 Pine Street, N. Y. City.

DAVIS & FARNUM MFG. CO.,

WALTHAM, MASS.

PRINCIPAL OFFICE AND WORKS, Waltham, Mass.

BOSTON OFFICE, Room 55, Mason Building, 70 Kilby Street.

SINGLE, DOUBLE,
AND
TRIPLE LIFT

Gas holders.

OF ANY CAPACITY.

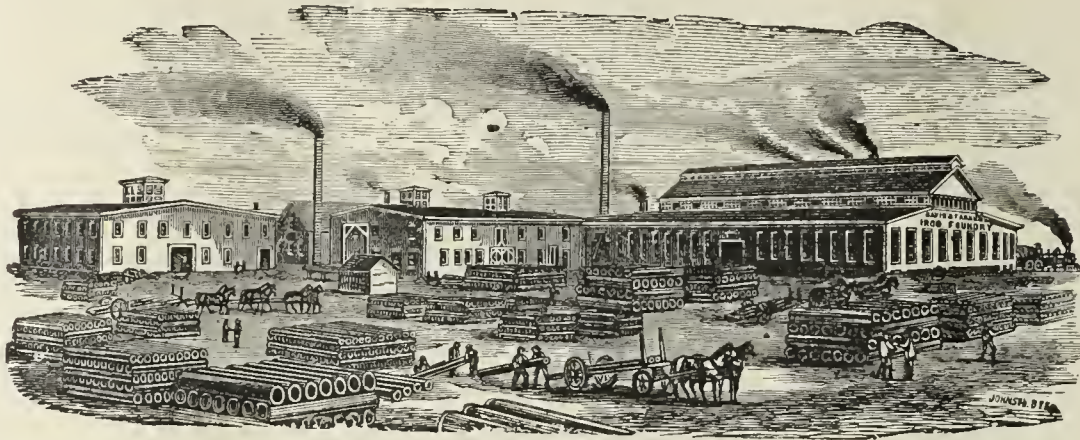

TUBULAR, PIPE,
AND
SINUOUS FRICTION

Condensers.

OF ALL SIZES.

IRON ROOF FRAMES AND FLOORS.

Purifying Boxes, Center Seal or Valve Connections, Bench Work.

Reversible Lime Trays.

SELF-SEALING AND PRESSED STEEL MOUTHPIECE LIDS.

Coke Barrows, Coal Wagons, and all Apparatus Requisite for a Complete Gas Plant.

— ALSO —

Gas and Water Pipe, Flanged Pipe,

Sugar House Work, and Special Castings of all Descriptions.

Established 1861.

Incorporated 1881.

KERR MURRAY MFG. CO.,

FORT WAYNE, IND.

Those who are in need of

Holdings of Gas Works Apparatus of any Description,

AND OF THE LATEST IMPROVEMENTS,

will find it to their interest to

GET AN ESTIMATE FROM US

before placing their order.

As we make a Specialty of this Class of Work, and are Practical Builders and Manufacturers of same,

with our long years of experience in the business,

WE CAN GUARANTEE YOU SATISFACTION.

Estimates, Plans and Specifications Furnished on Application.

BARTLETT, HAYWARD & CO.

Baltimore, Md.

Triple Double, & Single-Lift

GASHOLDERS.

Iron Holder Tanks.

ROOF FRAMES.

Cirders.

BEAMS.

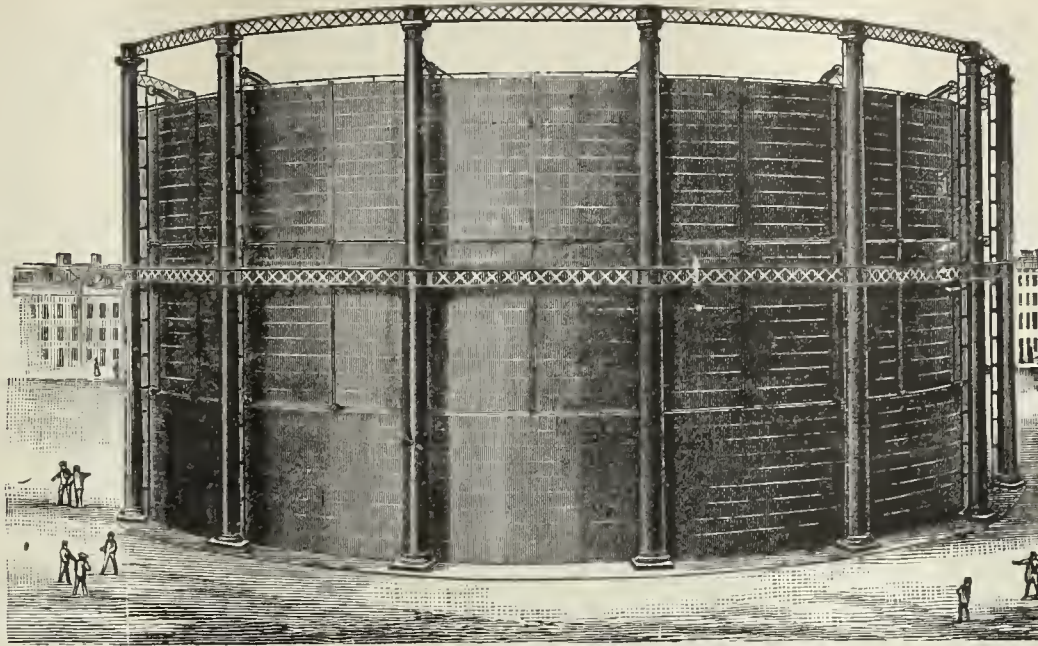

PURIFIERS.

CONDENSERS.

Scrubbers.

BENCH CASTINGS.

OIL STORAGE TANKS.

Boilers.

The Wilkinson Water Gas Process.

THIRTY-CANDLE, NON-CONDENSABLE, FIXED GAS. THE MOST SUCCESSFUL GAS PROCESS IN OPERATION.

Munich Regenerative Furnace, System Drs. Schilling & Bunte.

HAZELTON BOILERS.

Gas Works Designed and Constructed.

Pascal Iron Works. ESTABLISHED 1821. Delaware Iron Works.

MORRIS, TASKER & CO.,

INCORPORATED.

OFFICE, 224 SOUTH THIRD STREET, - - PHILADELPHIA, PA.

CONTRACTORS, BUILDERS, AND MANUFACTURERS OF

Gas, Water & Sugar Works

Bench Castings.

Condensers.

Scrubbers.

Purifiers.

Hyd. Carriages.

Iron Floors,

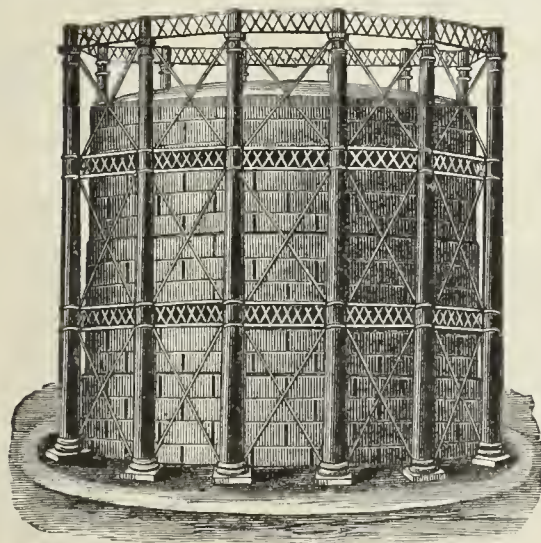

Iron Roofs.

Street Stops,

Valves, etc.

Stand-Pipes.

Water & Oil

Tanks, all Sizes.

Single, Double, and Triple-Lift Gas Holders.

SELF-SEALING RETORT LIDS. STAMPED STEEL RETORT LIDS.

Locomotive Water Columns, Filters, etc. Boiler Tubes, Wrought Iron Pipe & Fittings

Plans, Specifications and Estimates for all kinds of Machinery furnished on application.

Foundries & Works,
MILLVILLE, FLORENCE,
and CAMDEN, N. J.

R. D. WOOD & CO.,

Engineers,
Iron Founders,
and
Machinists.

400 Chestnut St., PHILADELPHIA, PA.

MANUFACTURERS OF

CAST IRON PIPE,

Gas Holders,

SINGLE, DOUBLE, AND TRIPLE LIFTS, WITH
OR WITHOUT WROUGHT IRON
OR STEEL TANKS.

PURIFIERS, CONDENSERS.

Scrubbers.

BENCH WORK.

Iron Floors and Roofs, Plate Girders.

Heavy Loam Castings.

HYDRAULIC WORK.

Lamp Posts, Valves, Etc.

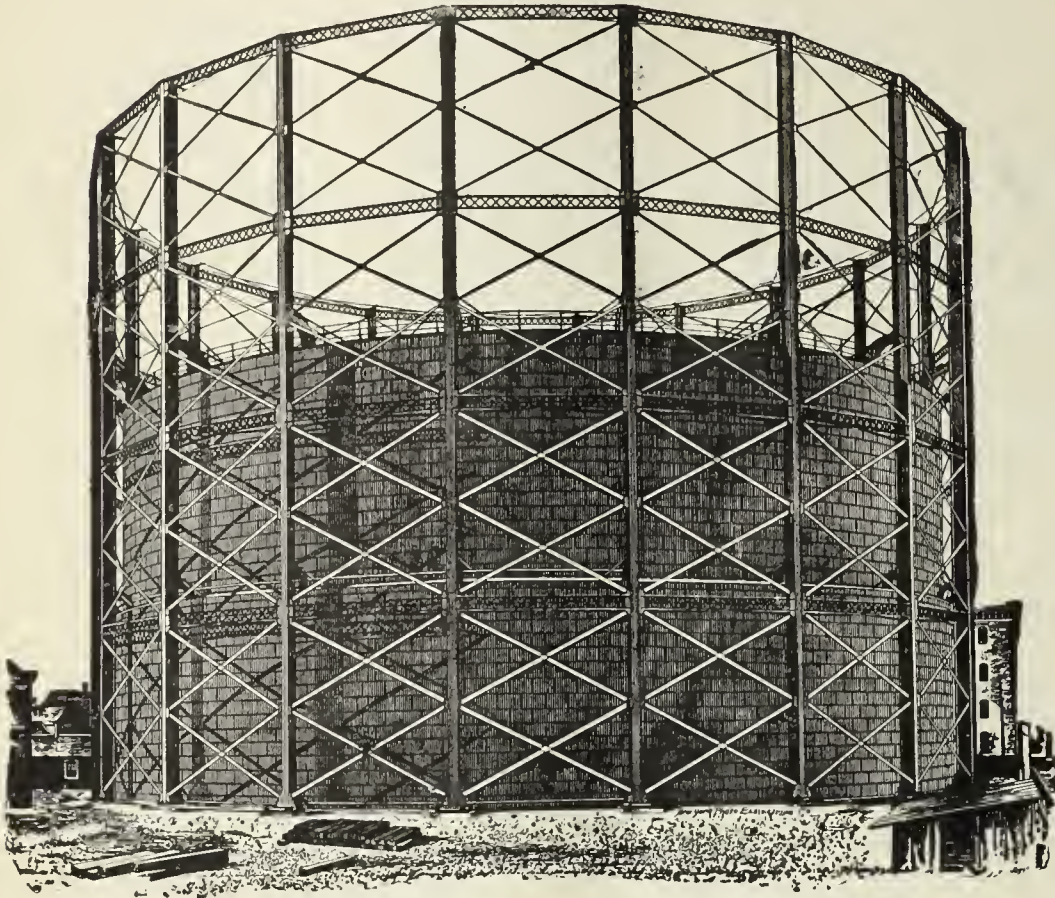

SMITH & SAYRE MFG. COMPANY,

G. G. PORTER, Prest.

245 Broadway, N. Y.

CHAS. W. ISBELL, Sec'y.

Machinery & Apparatus for Gas Works

Drawings, Plans, and Estimates Furnished for the Improvement, Extension, or Alteration of Gas Works, or for the Construction of New Works.

Mackenzie's Patent Rotary and Steam Jet Gas Exhausters, Governors, Compensators, Condensers, Washers, Scrubbers. Isbell's Patent Automatic Street Pressure Governor, Gas and Water Valves, Hydraulic Main Dip Regulator, Bench Castings, etc. Purifying Boxes and "Standard" Scrubbers, Isbell's Patent Self-Sealing Retort Doors.

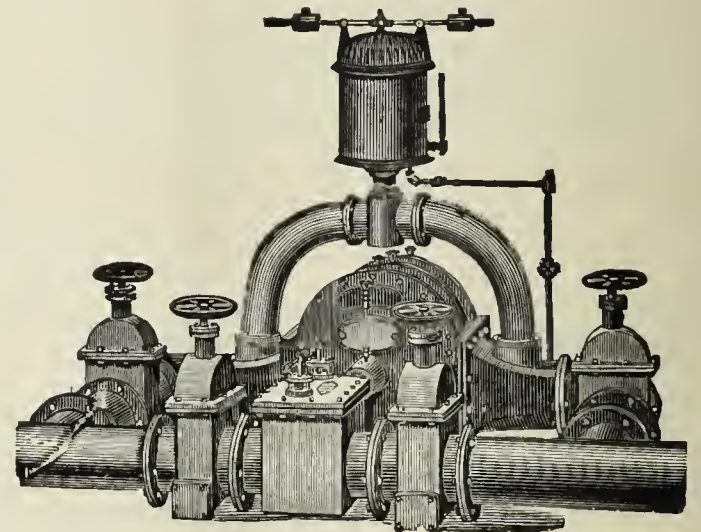

THE BRENNER SELF-SEALING RETORT DOOR. Simple, Strong, and Durable.

CLOSES ABSOLUTELY TIGHT & IS LOCKED BY A CAM LEVER. ALL NECESSARY ADJUSTMENT FOR WEAR PROVIDED.

BUILT BY

SMITH & SAYRE MFG. CO.,

No. 245 Broadway, - - - New York City.

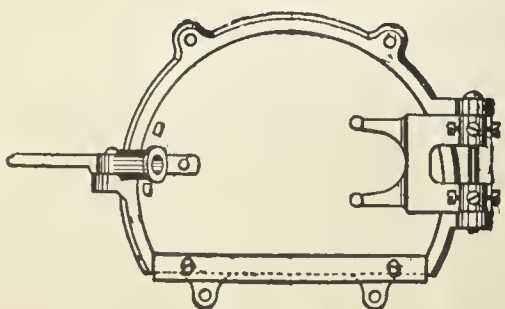

Brenner Self-Sealing Retort Door.

WILLIAM B. LUNDIE, Superintendent of the 42d Street Station of the Consolidated Gas Company, of New York, writes, under date of Jan. 4, 1889:

"We have 320 Brenner Self-Sealing Lids in use at this Station, built by the Smith & Sayre Mfg. Co. They require very little attention, and are the best of the kind that I have seen, giving entire satisfaction."

GAS WORKS APPARATUS AND CONSTRUCTION.

GAS WORKS APPARATUS AND CONSTRUCTION.

JAMES R. FLOYD & SONS,

(SUCCESSORS TO HERRING & FLOYD)

Oregon Iron Works,

W. 20th & 21st. Sts., bet. 10th & 11th Avs.,

NEW YORK CITY.

Engineers and Contractors

FOR THE

CONSTRUCTION OF GAS WORKS.

MANUFACTURERS OF

All Kinds of Castings and General Ironwork

FOR

GAS APPARATUS.

Bench Castings, Regenerative and Half Regenerative Furnace Castings.

Condensers, Scrubbers, Purifiers, Street Drips and Connections,

Valves,

Hydraulic Hoisting Purifier Carriage, Self-Sealing Retort Lids, Improved Valve Stand and Indicator, Seller's Cement.

Plans, Specifications, and Estimates furnished for Construction of New or Alteration of Old Works.

CONTINENTAL IRON WORKS.

THOS. F. ROWLAND, Prest.

WARREN E. HILL and CHAS. H. CORBETT, V-Prests.

THOS. F. ROWLAND, JR., Sec. & Tr

P. O. Station G., BROOKLYN, N. Y.

ENGINEERS AND MANUFACTURERS OF

Gas Holders

CONDENSERS, SCRUBBERS, VALVES,

PURIFIERS, SELF-SEALING RETORT LIDS

Hydraulic Mains,

And all other articles connected with the manufacture and distribution of Gas.

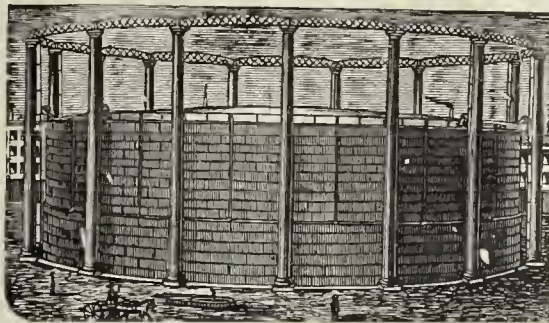

H. RANSHAW, Prest. & Mangr.

WM. STACEY, Vice-Prest.

T. H. BIRCH, Asst. Mangr.

R. J. TARVIN, Sec. & Treas.

STACEY MFG. CO.,

MANUFACTURERS OF

Single and Telescopic Gasholders,

IRON ROOFS, BRIDGES, LAMP POSTS,

Water and Oil Tanks, Coal Elevator Cars, COKE CRUSHERS, BENCH CASTINGS,

And all kinds of Wrought and Cast Iron Work used in the erection of Coal and Oil Gas Works Rolling Mill Machinery and Heavy Castings a Specialty.

Foundry:

33, 35, 37 & 39 Mill Street.

Wrought Iron Works:

16, 18, 20, 22, 24 & 26 Ramsey Street:

Cincinnati, Ohio.

Bouton Foundry Co.,

FOUNDERS AND MACHINISTS,

CHICAGO, ILL.

Gas Works Apparatus,

PURIFIERS, CONDENSERS,

Bench Work

SPECIALS, LAMP POSTS,

SCRUBBERS,

Iron Roofs and Floors.

Plans and Estimates furnished for new works or extensions of old works.

1842. **DEILY & FOWLER,** 1890.

Laurel Iron Works.

Address, No. 39 Laurel Street, Philadelphia, Pa.

BUILDERS OF

GASHOLDERS,

Single and Telescopic.

HOLDERS BUILT 1884 to 1888, Inclusive:

- | | | | | |
|----------------------------|-----------------------------|---------------------------|--------------------------|------------------------|
| Newport, R. I. | Long Island City, N. Y. | Port Chester, N. Y. | Malden, Mass. | West Chester, Pa. (2d) |
| Portland, Oregon. | Macon, Ga. | New Rochelle, N. Y. | Paducah, Ky. | Lancaster, Pa. (3d) |
| Allegheny, Pa. (2d.) | York, Pa. | Salem, N. J. (3d) | Norwich, Conn. | Faeny, Pa. (two) |
| Atlanta, Ga. (2d.) | Chester, Pa. | Omaha, Neb. (2d) | Seattle, W. T. | Mount Vernon, N. Y. |
| N.Y. City (Central Gas Co) | Hazleton, Pa. (2d.) | Lynn, Mass. (2d) | San Diego, Cal. | Binghamton, N. Y. |
| Lynchburg, Va. (2d.) | Staten Island, N. Y. | Little Rock, Ark. | Northern Gas Lt. Co., of | Concord, N. H. |
| Saylesville, R. I. | Saugerties, N. Y. | Irvington, N. Y. | New York, N. Y. | Dover, Del. (2d) |
| Rondout, N. Y. | Clinton, Mass. (Lan. Mills) | South Boston, Mass. | Westerly, R. I. | Calais, Me. |
| Atlantic City, N. J. | Chattanooga, Tenn. | Rye, N. Y. (2) | Willimantic, Conn | New London, Conn. (2d) |
| Augusta, Ga. | Galveston, Texas. (3d.) | Woodstock, Ont. | Montclair, N. J. | West Chester, N. Y. |
| Waltham, Mass. (2) | Omaha, Neb. | Malden, Mass. | Attleboro, Mass. | Bay Shore, L. I. |
| Mahanoy City, Pa. | Fort Plain, N. Y. | Staten Island, N. Y. (2d) | Santa Cruz, Cal. | Washington, D. C. |
| New Castle, Pa. | Brunswick, Ga. | Woodstock, Ont. | Erie, Pa. (2d) | |

WM. HENRY WHITE,

No. 32 Pine Street, - - - New York City.

ENGINEER AND CONTRACTOR FOR THE

ERECTION AND EXTENSION OF

GAS, WATER, AND ELECTRIC LIGHT WORKS.

Correspondence with Gas Companies contemplating extending or improving their Plants respectfully invited.

Plans and Estimates Furnished.

GAS COALS.

CANNEL COALS.

GAS ENRICHERS.

JAMES D. PERKINS. **PERKINS & CO.,** F. SEAVERN.
228 & 229 Produce Exchange, New York.

Cable Address, "PERKINS, NEW YORK."

Post Office Box 3695, New York.

GENERAL SALES AGENTS FOR

The Youghiogeny River Coal Company's

OCEAN MINE YOUGHIOGHENY GAS COAL.

HON. W. L. SCOTT, Prest.

M. H. TAYLOR, Vice-Prest.

This Colliery is located at SCOTT HAVEN, PA., in the center of the Youghiogeny Gas Coal District, and produces the ONLY RELIABLE YOUGHIOGHENY COAL for gas purposes. (See Map on p. 87 of this JOURNAL, Feb. 16, '85.)

POINTS OF SHIPMENT,

Locust Point, BALTIMORE.

Pier No. 62, PHILADELPHIA.

Also, SOLE AGENTS for the

**BRECKENRIDGE CANNEL,
OF KENTUCKY.**

Within the past two years we have delivered this Cannel to over ONE HUNDRED COMPANIES IN THIRTY-THREE DIFFERENT STATES, and it is now in use in some of the large Gas Works

On the Continent and in South America,

where it successfully competes with the Australian Shale. It is the ONLY AMERICAN GAS CANNEL of sufficiently high grade to warrant EXPORTATION TO EUROPE AND SOUTH AMERICA, and it is the only economical substitute for OIL OR NAPHTHA. ONE GROSS TON will produce

10,000 Cubic Feet of 75 Candle Gas,	} equal to {	750,000 Candle Feet of Gas, and 26 Bushels of merchantable Coke weighing 900 Pounds
or 12,500 " " 60 " "		
or 15,000 " " 50 " "		

This is the ONLY GAS CANNEL that will produce a REALLY MERCHANTABLE COKE. It can be delivered in parcels of one carload or more to any point in the United States or Canada. Cargo shipments of any size required can be made from NEW YORK, PHILADELPHIA, BALTIMORE, or NEWPORT NEWS. Samples will be sent and particulars of price, etc., forwarded upon application to above address.

JAMES & WILLIAM WOOD,
Gas and Cannel Coal Contractors,

No. 40 St. Enoch Sq., Glasgow. No. 2 Talbot Court, London.

Proprietors of the BATHVILLE COLLIERIES (which produce the celebrated BOGHEAD CANNEL), Shields, Shieldmuir, Drumpeller, and other Collieries. This Firm offer

STANDARD CANNELS,

Unequaled as Gas Enrichers.

Analyses, prices, and all further information furnished on application to
Agency for U.S., Room 70, Nos. 2 & 4 Stone St., N.Y. City.

The Standard Oil Company,

REFINERS OF

NAPHTHA AND GASOLINES.

ALSO MANUFACTURERS OF

A Special Grade of Naptha for Gas Companies

FOR ENRICHING COAL GAS.

Correspondence solicited.

No. 43 Euclid Avenue, Cleveland, Ohio.

To Gas Companies.

We make to order CAP BURNERS to burn any amount under a stated pressure. Send for samples.

Also, SERVICE CLEANERS, DRIP PUMPS, and STREET MAIN PROVING APPARATUS.

O. A. GEFROER,

248 N 8th Street, Phila., Pa.

COKE CRUSHERS.

GAS COALS.

GAS COALS.

Newburgh Orrel Coal and Coke Co.

MINERS AND SHIPPERS OF

STEAM, SMITHING, AND GAS COALS,
Foundry and Crushed Coke.

Home Office, 33 S. Gay Street, Baltimore, Md.

J. HARRY LEE, President.

Shipping Wharves, Locust Point, Baltimore.

The Despard Gas Coal Co.,

MINERS AND SHIPPERS OF

DESPARD GAS COAL,

AND MANUFACTURERS OF

COKE.

MINES, Clarksburg, Harrison Co., W. Va.

WHARVES, Locust Point, Baltimore, Md.

OFFICE, 225 E. German St., " "

ROUSSEL & HICKS, } AGENTS. } BANGS & HORTON,
71 Broadway, N. Y. } 60 Congress St., Boston.

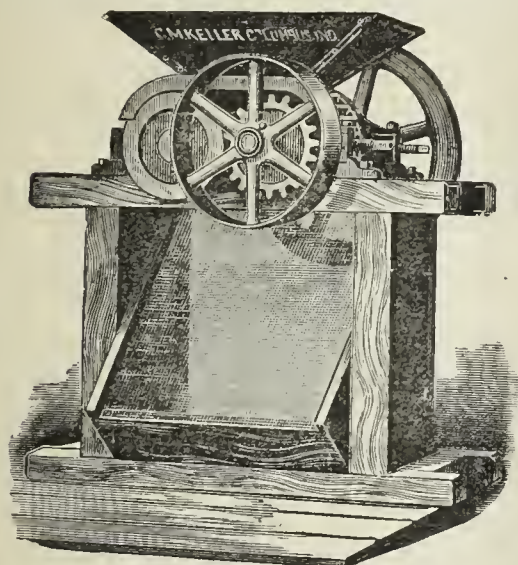

Keller's Adjustable Coke Crusher

SIMPLE, STRONG, AND DURABLE.

C. M. Keller, Sec. & Supt. Gas Lt. & Coke Co. Columbus, Ind.

Correspondence Solicited.

King's Treatise on Coal Gas.

The most complete work on Coal Gas ever published.

Three Vols. Bound, \$30.

BOOKS.

DISTILLATION OF COAL TAR AND AMMONIACAL LIQUOR.

By GEORGE LUNGE. Price \$12.50.

A TREATISE ON THE COMPARATIVE COMMERCIAL VALUES OF GAS COALS AND CANNELS.

By DAVID A. GRAHAM. 8vo., Cloth. Price \$3.

Orders for these books may be sent to this office.

A. M. CALLENDER & CO.,

42 Pine St., N. Y. City

THE PENN GAS COAL CO.

OFFER THEIR

Coal, Carefully Screened & Prepared for Gas Purposes.

Their Property is located in the Youghiogheny Coal Basin, near Irwin and Penn Stations on the Pennsylvania Railroad, and on the Youghiogheny River.

Principal Office:

209 SOUTH THIRD STREET, PHILA., PA.

Points of Shipment:

Pennsylvania Railroad Piers; Greenwich Wharves, Delaware River; Pier No. 1 (Lower Side), South Amboy, N. J.

Chesapeake & Ohio Railway Coal Agency,

FOR THE SALE OF THE

Superior Kanawha Gas Coals, Cannelton Cannel, Also, SPLINT AND STEAM COALS

From the Kanawha and New River Regions, on the line of the Chesapeake & Ohio R'way.

C. B. ORCUTT, General Agent, - - No. 1 Broadway (Room 217) New York City.

FRANCIS H. JACKSON, Prest.

EDMUND H. MCCULLOUGH, V.-Prest.

CHAS. F. GODSHALL, Treas.

H. C. ADAMS, Sec.

THE WESTMORELAND COAL CO.

Chartered 1854.

Mines situated on the Pennsylvania and the Baltimore and Ohio Railroads, in Westmoreland County, Penn.

POINTS OF SHIPMENT:

PHILADELPHIA, BALTIMORE, SOUTH AMBOY, N. J., WATKINS (SENECA LAKE), N. Y.

Since the commencement of operations by this Company its well-known Coal has been largely used by the Gas Companies of New England and the Middle States, and its character is established as having no superior in gas giving qualities, and in freedom from sulphur and other impurities.

Principal Office, 224 South 3d St., Phila., Pa.

The American Gas Engineer and Superintendent's Handbook.

By **WILLIAM MOONEY.**

Consisting of Rules, Reference Tables, and Original Matter Pertaining to the Manufacture, Manipulation, and Distribution of Illuminating Gas.

350 Pages, Full Gilt Morocco.

\$3.00.

A. M. CALLENDER & CO., 42 Pine St., N. Y.

JOHN J. GRIFFIN & CO.,

Nos. 1513, 1515, 1517 & 1519 Race Street, PHILADELPHIA.
52 Dey St., NEW YORK. 75 N. Clinton St., (FRED. R. PERSONS, Mangr.) CHICAGO.

MANUFACTURERS OF

METERS FOR MEASURING GAS

IN ANY VOLUME.

Provers, Gauges, Registers, Etc., Etc

EXPERIMENTAL APPARATUS FOR QUANTITATIVE AND QUALITATIVE ANALYSIS.

Careful and Prompt Attention paid to Repairing of all kinds of Meters and Apparatus.

Estimates Cheerfully Furnished.

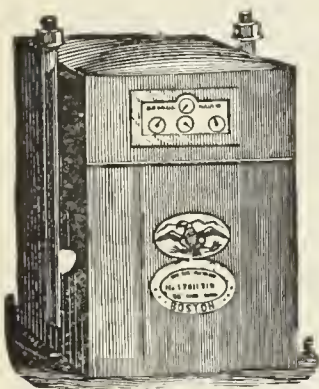

Dry Gas Meters.

With 40 years' experience and the best facilities for manufacturing, is enabled to furnish reliable work and answer orders promptly.

NATHANIEL TUFTS,

No. 153 Franklin Street, Boston, Mass.,

MANUFACTURER OF

DRY GAS METERS.

Station Meters of any Capacity.

Test and Experimental Meters, Pressure Registers, Pressure Gauges, Pressure and Vacuum Gauges.

METER PROVERS, PHOTOMETERS, STREET LANTERNS, ETC., ETC.

Patent Cluster Lanterns for Street Illumination.

HAROLD J. BELL.

BELL & JONES,

S. LEWIS JONES.

No. 12 North Ninth Street, Philadelphia, Pa. Works at Royersford, Pa.

MANUFACTURERS OF

GAS METERS, STATION AND EXPERIMENTAL METERS,
Meter Provers, Pressure Gauges, and All Other Gas Appliances in Our Line.

WE REPAIR ALL KINDS AND MAKES OF METERS, AND THE WORK GUARANTEED.

High Pressure Meters for Natural Gas, in Iron Cases, guaranteed to stand 300 lbs. Pressure.

Gas Cooking and Heating Stoves, Hot Plates, Cake Griddles, Waffle Bakers, Boiling Stoves, Laundry and Tailors' Iron Heaters. Hotel and Cafe Ranges a Specialty.

Correspondence Solicited.

Estimates Furnished.

A. HARRIS.

E. L. HARRIS.

J. A. HARRIS.

Established 1849.

HARRIS BROS. & CO.,

Twelfth and Brown Streets, Philadelphia.

Manufacturers of Wet and Dry Gas Meters,

STATION METERS, METER PROVERS,

EXPERIMENTAL METERS, SHOW OR GLAZED METERS,

Pressure and Vacuum Registers, Gauges, Photometers, Drip and Bell Pumps, Etc., Etc.

PROMPT ATTENTION GIVEN TO ALL ORDERS. METERS THOROUGHLY REPAIRED. ESTIMATES FURNISHED FOR STATION METERS OF ALL SIZES, CORRESPONDENCE SOLICITED,

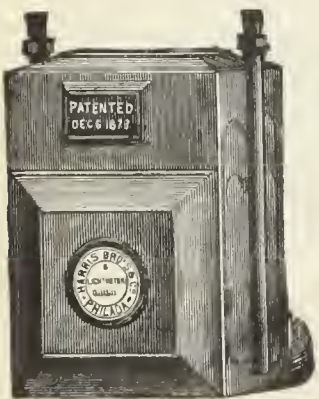

GAS METERS.

GAS METERS.

GAS METERS.

GEO. J. MCGOURKEY, Prest.

WM. H. MCFADDEN, Vice-Prest. (Phila.)

WM. N. MILSTED, Gen. Supt. and Treas. (New York).

WM. H. DOWN, Sec.

THE AMERICAN METER CO.

Established 1834.

Incorporated 1863.

WET AND DRY GAS METERS.

PRESSURE REGISTERS.

METER PROVERS.

STATION METERS.

PRESSURE & VACUUM REGISTERS.

PORTABLE TEST METERS.

EXHAUSTER GOVERNORS.

PRESSURE & VACUUM GAUGES.

EXPERIMENTAL METERS.

DRY CENTER VALVES.

CRESSON GAS REGULATORS.

AMMONIA TEST METERS.

GOVERNORS FOR GAS WORKS.

MARSLAND WATER METERS.

BAR & JET PHOTOMETERS.

Manufactories:

512 West 22d St., N. Y.

Arch & 22d Sts., Phila.

GAS STOVES.

SUGG'S "STANDARD" ARGAND BURNERS,
SUGG'S ILLUMINATING POWER METER,
Wet Meters, with Lizar's "Invariable Measuring" Drum.

Agencies:

177 Elm Street, Cincinnati.
244 & 246 N. Wells Street, Chicago.
810 North Second Street, St. Louis.
222 Sutter Street, San Francisco.

HELME & McILHENNY,

(Established 1848.)

GAS METER MANUFACTURERS,

Nos. 1339 to 1349 Cherry Street, Philadelphia, Pa.,

WET AND DRY GAS METERS. STATION METERS, EXPERIMENTAL METERS, METER PROVERS,

Center Seals, Pressure Registers, Governors, Indicators, Photometers, and all other kinds of Apparatus for use in Gas Works.

FOULIS' PATENT STATION AND DISTRICT GOVERNORS.

REPAIRING DEPARTMENT.—We employ a special force of skilled workmen repairing meters of all makers.

WM. WALLACE GOODWIN, President and Treasurer.

E. STEIN, Vice-President.

H. B. GOODWIN, Secretary and Superintendent.

THE GOODWIN GAS STOVE AND METER CO.,

Successors to W. W. GOODWIN & CO.

1012, 1014 and 1016 Filbert St., Phila., Pa.

113 Chambers St., New York City.

76 Dearborn, St., Chicago, Ills

WALDO BROTHERS, Agents, 88 Water Streets, Boston, Mass.

MANUFACTURERS OF

DRY AND WET GAS METERS,

Station Meters (square, cylindrical, or in staves), Glazed Meters, King's and Sugg's Experimental Meters, Lamp Post Meters, etc., etc. Meter Provers (sizes 2, 5, and 10 feet), Pressure Gauges of all kinds, Pressure Registers, Pressure and Vacuum Registers, Pressure Indicators (sizes 4, 6, and 9 inch), King's Pressure and Vacuum Gauges, Dry and Wet Center Seals, Dry and Wet Governors, Exhauster Governors, Photometers of all descriptions. Letheby's Sulphur and Ammonia Test Apparatus complete. Also, Testing and Chemical Apparatus of all kinds, and of the most perfect description, for all purposes relating to Gas.

Manufacturers of the "SUN DIAL" GAS STOVES, for Cooking and Heating.

Goodwin's Improved Lowe's Jet Photometer.

Agents for Bray's Patent Gas Burners and Lanterns.

Special attention to Repairs of Meters and all Apparatus connected with the business. All work guaranteed first-class in every particular. Orders filled promptly.

G. B. EDWARDS, Manager, New York.

S. S. STRATTON, Manager, Chicago.

D. McDONALD & CO.,

GAS METER MANUFACTURERS.

(Established 1854.)

51 Lancaster St., Albany, N. Y. 34 & 36 West Monroe St., Chicago, Ill.

STATION METERS, EXPERIMENTAL METERS, METER PROVERS, PRESSURE & VACUUM REGISTERS, PRESSURE GAUGES, ETC.

Also STAR GAS STOVES, RANGES, and HEATING STOVES.

We use only the very best materials, and employ the most skilled labor, and by our long experience (36 years) and personal supervision of every detail, we feel justified in assuring the public that our goods will give perfect satisfaction. Every Meter emanating from our establishment will bear the State Inspector's BADGE, and will be fully warranted by us. Our Annual and Calendar will be sent to Gas Companies upon application.

GAS INTO POWER,

BY THE

OTTO GAS ENGINE.

GAS POWER.—A Source of Revenue to Gas Companies ready to engage in Electric Lighting, building of Water Works, Electric Street Railways, etc.

Coal for producing Gas is less in amount than that for producing Steam, both being measured on an equal amount of work performed. And, further, with Gas,

50 to 90 per Cent. of Value of Coal is Returned

by sale of Coke and Tar, according to the market value of these products.

Labor for handling fuel is reduced, by its becoming centralized and confined to the gas house, and frequently has not increased after the addition of a power station.

With Gas Power, cost of fuel is strictly limited to the time of use.

MANY VALUABLE
AND RECENT
IMPROVEMENTS.

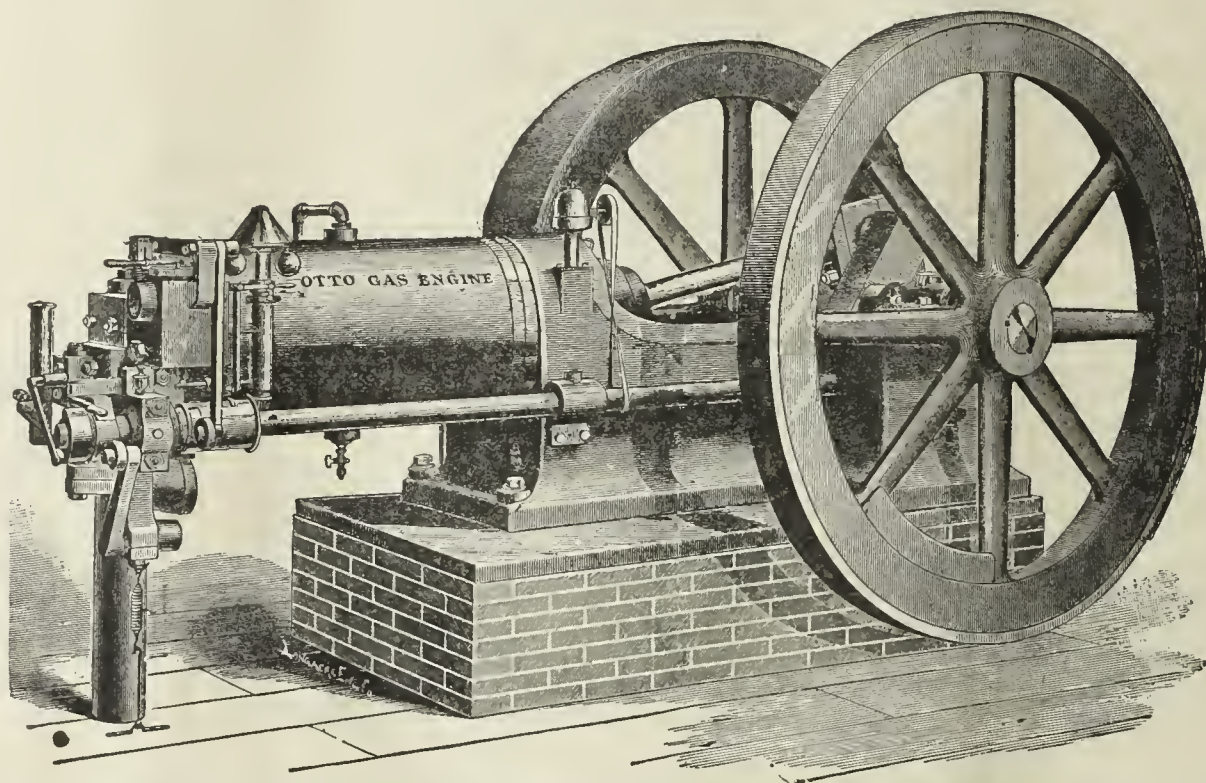

SIZES,
1-3 to 100
HORSE POWER.

Wherever Gas Companies tried Gas Power with Steam Power together in one Station, the use of Steam was subsequently abandoned or restricted, and Gas Power made to take its place.

Where Gas Companies adopt Gas Power for Electric Plants, Water Works, Sewerage, etc., they not only choose the most economical power for their use, but secure to themselves the numerous advantages of increased production, without increase of expense, and benefit thereby their entire manufacture. They induce consumers, by their example, to abandon Steam for Gas Power, and, by establishing special rates, make

Gas Power the Leading Power of To-Day,
AND SOLVE AT ONCE THE QUESTION OF FUEL GAS.

“Otto Gas Engine Works,”

SCHLEICHER, SCHUMM & CO.,

151 Monroe St. (Kent building), Chicago.

33d & Walnut Sts., Phila.

NEW YORK AGENCY, 18 VESEY STREET,

THE AMERICAN

GAS LIGHT JOURNAL

REDMAN & KENNY, N. Y.

PUBLISHING OFFICE NO. 42 PINE STREET

DEVOTED TO THE INTERESTS OF ILLUMINATION, VENTILATION, WATER SUPPLY AND DISTRIBUTION, & GENERAL SCIENCE.

VOLUME LII.—No. 23.
Whole No. 783.

NEW YORK, MONDAY, JUNE 9, 1890.

{ \$3 PER ANNUM,
IN ADVANCE. }

A. M. CALLENDER & CO., Proprietors. C. E. SANDERSON, Manager.
W. R. THOMAS, C.E., Editor. T. J. CUNNINGHAM, Asst. Editor.

ENTERED AT THE POST OFFICE AT NEW YORK, N. Y.
AS SECOND CLASS MATTER.

Published on each Monday of the year, at No. 42 Pine Street, N. Y.

Terms of Subscription, Including Postage.—For the United States and Canada, \$3 per annum. European countries, \$4.50 (19 shillings—22½ francs). All payments to be made in advance. Single copies, 10 cents.

Remittances should be made either by post-office order, registered letter, or bank draft on New York, payable to the order of A. M. Callender & Co.

Collections are invariably made directly from this office, for subscriptions, advertisements, etc. We have agents to solicit the same, but they are not authorized to receipt for money.

CONTENTS.

An Asterisk (*) denotes an illustrated article.

EDITORIALS—

The Associated Press Once More.....	801
Briefly Told.....	801
List of Exhibitors at the St. Louis Gas Apparatus Display—Notes—The Greenville (S. C.) Municipal Electric Lighting Plant—Annual Meeting, Port Hope, Ont., Company.	
The Market for Gas Securities.....	802
Thirteenth Annual Meeting Western Gas Association—Official Report, Revised by the Secretary—Continued from Page 777.....	802
Election of New Members—Electing Mr. Leach an Honorary Member—The Relative Value of Gaseous Fuels, by Mr. B. E. Chollar—Discussion—In Memoriam Proceedings—Eulogy on Ex-President King, by Mr. George G. Ramsdell—Capt. White's Tribute—Tribute of Mr. Somerville—Report of Committee on Memorial Resolutions—The King Memorial—The Forstall Memorial—The Arndt Memorial—The Cosgrove Memorial—The Fullagar Memorial—Calling Attention to the Exhibition of Gas Apparatus.	
The Massachusetts Supreme Judicial Court Differs from Attorney-General Waterman.....	809
*Note on a New Photometer for Measuring Electric Lighting Values, by Prof. Ed. L. Nichols.....	810
Improvements at Clinton, Mo.....	811

ITEMS OF INTEREST FROM VARIOUS LOCALITIES..... 811

Advancing at Tacoma—Raising Electric Lighting Rates, Paterson, N. J.—Testimonial to the Late William H. Williams—Meter Awards, Philadelphia—San Francisco Makes Rules about Imperfect Gas Fixtures—Tar Goes Higher, at Lynn, Mass.—Coke at Louisville—Wilkinson Plant for Milwaukee, Wis.—Public Lighting, Paterson, N. J.—The Probable Cost—Contracts—Gas Works for Riverside, Ia.—Gas Explosion—Hints from Rockville, Conn.—Public Lighting, Kansas City, Mo.—Changes in the New Bedford (Mass.) Company's Management—More Work for the Berlin Bridge Company—And Many Other Items.

THE Welsbach Company has purchased a controlling interest in the Siemens-Lungren Company, and will hereafter manage its affairs. The new officers of the Siemens-Lungren Company are: President, Col. W. E. Barrows; Secretary and Treasurer, E. C. Lee; Directors, Messrs. Gibbs, Bodine, Barrows, Lee and Morgan. The same capitalists have secured control of the United Gas Lamp Company, and these properties, together with the Welsbach, give the consolidated enterprise a wide field. The manufacturing department will be carried on at Gloucester, N. J. Mr. Edward Stein, who may fairly be called the father of regenerative gas lighting in this country, will turn his attention to sugar refining, representing in the East a large Western manufacturing firm. That he will be successful goes without saying.

THE ASSOCIATED PRESS ONCE MORE.

The following letter, from Mr. H. C. Bolcom, explains itself:

OFFICE OF WINONA GAS LIGHT CO.,
WINONA, MINN., May 24, 1890.

To the Editor AMERICAN GAS LIGHT JOURNAL: Why is there such a difference in the price of gas lamps for New York city? The letting of the contract to the Equitable Company for 3,600 lamps at \$12 was telegraphed to the West—by the Associated Press, I presume—but nothing in regard to the \$28 lamps, as you report. I presume other Western managers would like to know how it comes about. I hope to be able to do something with our City Fathers, as soon as their electric light contract expires, and would have preferred the whole truth in regard to the New York city contract, instead of what we got.

Yours truly,
WINONA GAS LIGHT CO., by
H. C. BOLCOM, Mgr.

In explanation of the figures quoted above we may say that the Equitable Company can charge no higher rate than \$12 per annum for each public gas lamp along its lines of mains, because its charter contains a provision to that effect. In other words, the \$12 rate—all public gas lamps in New York city are fitted with burners rated to 3 feet per hour, and each lamp is lighted during a total of 4,000 hours per annum—is in the nature of a concession to the city for the privilege granted the Equitable Company of occupying the streets with its mains. At the figures paid the Equitable, of course the Company operates its street lighting service at a loss. The \$28 lamps mentioned are in the suburban districts, and many of the posts are over lines of mains that were laid especially for the public lighting service. Of course, the Associated Press man, in order to be sensational, merely forwarded the low rate; there would be nothing sensational in the figures about the awards made on the basis of nothing better than a charge that would enable a bare living to the contractor. We herewith reprint the figures on which the present public gas lamp award was made:

Name of Company.	No. Lamps.	Price per Lamp.
Consolidated	17,150.....	\$17.50
Mutual	280.....	17.50
Equitable.....	3,600.....	12.00
*Central.....	2,675.....	27.00
*Northern	2,200.....	28.00
*Yonkers.....	557.....	28.00

* Suburban districts, sparsely settled.

BRIEFLY TOLD.

THE following is a complete list of the exhibitors and exhibits at the display of gas apparatus, etc., held in connection with the annual meeting of the Western Gas Association:

Home Comfort Range Co., St. Louis, Mo., gas stoves; Van Wie Gas Stove Co., Cleveland, O., gas stoves; Connelly & Co., N. Y., purifying material, automatic governors, etc., H. Muller Manufacturing Co., Decatur, Ills., tapping machines and fittings for water and gas pipe; Ringen Stove Co., St. Louis, gas stoves; Jewel Gas Stoves, Chicago; Hot Air Stove and Burner Manufacturing Co., St. Louis, gas heating

stoves; H. Heil, chemical apparatus for gas analysis, etc., St. Louis; Mutual Mining Co., Cannelburg, Ind., cannel coal; Automatic Safety Burner Co., N. Y.; Fay Gas Fixture Co., St. Louis, chandeliers, gas fixtures and stoves; Maryland Meter Co., stoves, meters, gauges, etc.; the Dangler Stove and Manufacturing Co., Cleveland, gas stoves; Goodwin Gas Stove and Meter Co., stoves, etc.; F. & L. Kahn & Bro., Hamilton, O., gas ranges; John Cabot, N. Y., purifier trays; Schneider and Trenholm Co., Cleveland, gas stoves; Chicago Gas Stove Co.; National Tube Works Co., 2 inch to 24 inch wrought iron gas pipe, bends, joints, etc.; Rumsey Manufacturing Co., St. Louis, lead pipe; Van Duzen Gas Engine Co., Cincinnati, gas engines; Economic Gas Engine Co., N. Y., gas engines; American Meter Co., test meters, photometers, gauges, registers, etc.; P. H. & F. M. Roots Co., Connerville, Ind., exhausters, valves, etc.; C. M. Keller, Columbus, Ind., coke crusher; Kerr Murray Mfg. Co., improved center valve for purifiers; Bailey, St. Louis, Mo., three-way valve for testing consumers' meters *in situ*.

NOTES.—The East Boston (Mass.) Gas Company is making extensive alterations on its main system. When these are finished the Company will have no "dead ends."—Mr. W. H. Snow, who has been Assistant Superintendent of the Holyoke (Mass.) works for some time, has been appointed Superintendent, vice the late Mr. L. D. Rhoades—Mr. Jas. A. Hadley, the efficient Superintendent of the Meriden (Conn.) Gas Light Company, was united in marriage, on the afternoon of May 28th, to Miss Marion P. Arnold, of Middletown, Conn. May they ever happy be.

THE advocates of municipal electric lighting stations are hereby informed of the fact that the authorities of Greenville, South Carolina, have sold out their municipal electric lighting station to Messrs. Asbury & Son, proprietors of the local gas works. The new owners agree to relieve the city of all pending liabilities in connection with the light plant, and the city agrees to take a certain number of lights at a fixed rental of \$100 per annum per lamp, the number to be not less than 40, the agreement to run for not less than 15 years.

THE 32d annual meeting of the shareholders in the Port Hope (Ont.) Gas Company was held in the last week of May, and the retiring Board of Directors was re-elected without opposition. Mr. John Smart was, of course, again chosen President. The earnings of the Company show a falling off from those of the previous year, which is accounted for on the ground that a reduction in gas rates of 20 per cent. was authorized, while the increase in sendout amounted to but a trifle over 5 per cent. This, however, is in reality a good showing, as the Company last year experienced the first effects of the competition of both incandescent and arc systems of electric lighting. The rates charged for the incandescent electric service are so ridiculously low that many consumers are now on the lines who will undoubtedly return to the use of gas when the electricians are obliged to put the rates at a figure anything like those which will yield a profit. President Smart, whose annual report is of an eminently practical nature, has firm faith in the stability of the Company, and gives it as his opinion that gas for cooking purposes will help him win the day at Port Hope.

MESSRS. CURRIER, of Boston, Mass., have secured the contract for the excavation and masonry for the new gasholder to be put up at the works of the Citizens Gas Light Company, Reading, Mass.

The Market for Gas Securities.

The feature of the week in the city market was the rise in Mutual gas, which sold at auction (90 shares) last Wednesday at 119. Consolidated is steady at 102½ to 103½, although there is little inquiry for the shares, speculators evidently holding the opinion that the maximum, at the present dividend rate, has been reached. Gov. Hill on Thursday last signed the bill regulating gas rates in New York State. Under it gas in New York city is put at \$1.25; in Brooklyn, \$1.50; in cities having between 100,000 and 500,000 population, \$2; elsewhere, companies may take what they can get. In the memorandum accompanying the signature, the Governor makes a strong plea for the appointment of a State Commission, like that of Massachusetts. Chicago gas is up to 54½, despite the appointment of Geo. H. Davis, a political hack of the Windy City, as "receiver" for the Trust under Judge Collins' decision. He won't have much to do, anyway. Bay State gas is up to 86. The Brooklyn situation may not be as smooth as it looks, for Contractor Devlin—of silent Equity charter fame—says that the Equity franchise will be sustained in the court of last resort.

[OFFICIAL REPORT—REVISED BY THE SECRETARY—CONTINUED FROM PAGE 777.]

THIRTEENTH ANNUAL MEETING OF THE WESTERN GAS ASSOCIATION.

HELD AT ST. LOUIS, MO., MAY 21, 22 AND 23, 1890.

FIRST DAY—AFTERNOON SESSION—MAY 21.

ELECTION OF NEW MEMBERS.

The business of the afternoon was ushered in by a report from the Committee on Membership Applications, who recommended that the following named gentlemen be elected to membership in the Association:

Active Members.

Adams, Dean, Little Rock, Ark.	Foster, R. M., St. Louis, Mo.
Bauer, T., Fort Scott, Kas.	Giesecke, G., San Antonio, Tex.
Bigger, L. A., Hutchinson, Kas.	Glover, Jr., J. B., Joplin, Mo.
Blodget, C. W., Brooklyn, N. Y.	Harper, Geo. H., Kansas City, Mo.
Boaz, O. T., Pittsburg, Kas.	Hill, J. M., St. Paul, Minn.
Bonnor, Alex., St. Louis, Mo.	Howes, S., Jackson, Tenn.
Brown, Geo. H., St. Louis, Mo.	Hunt, Hermon, Fort Dodge, Ia.
Butterworth, Irvin, Columbus, O.	McGaully, Peter, St. Louis, Mo.
Breithaupt, E. C., Berlin, Ont.	Miller, A. S., Omaha, Neb.
Byron, T., Birmingham, Ala.	Millington, D. A., Winfield, Kas.
Cathels, E., Joliet, Ills.	Penn, Jerome, Washington, O.
Clary, E. D., Burlington, Ia.	Ross, Alex., St. Louis, Mo.
Collins, Chas., Kewanee, Ills.	Rowe, John J., Cairo, Ills.
Darrah, S. M., Wheeling, W. Va.	Shaffner, S. C., Louisiana, Mo.
Davis, S. S., Moline, Ills.	Singel, Geo., Fort Smith, Ark.
Doan, F. M., Jacksonville, Ills.	Ward, Benj. A., Michigan City, Ind.
Ewing, G. W., E. St. Louis, Ills.	Wilson, W. M., Hot Springs, Ark.
Fitz, Robt. A., Elgin, Ills.	Woodman, F., Charleston, W. Va.
Foster, Jas. A., Montgomery, Ala.	Yuille, Geo. A., Chicago, Ills.

Associate Members.

Ashcroft, H. E., St. Louis, Mo.	Marquis, P. S., St. Louis, Mo.
Bingham, S. H., Chicago, Ills.	Morrell, E. E., Chicago, Ills.
Buss, J., New York, N. Y.	Reid, C. A., Chicago, Ills.
Gribbel, J., New York, N. Y.	Roper, Geo. D., Rockford, Ills.
Harris, A., Philadelphia, Pa.	Truesdale, J. R., St. Louis, Mo.
Higgins, C. M., Cleveland, O.	Weber, Oscar, New York, N. Y.
Hubbard, H. M., Chicago, Ills.	

On motion of Mr. Lansden, the Secretary cast the ballot of the Association for the election of the applicants.

ELECTING MR. LEACH AN HONORARY MEMBER.

Mr. J. B. Howard—We have with us to-day a distinguished member of the American Association and of the New England Association. He has visited us for many years, and in honoring us with his presence has traveled a great distance. He has, therefore, shown great appreciation of the Western Gas Association. He has every attribute of a gentleman and a good fellow, and I know there will not be a dissenting voice in this house when I move that the name of Mr. H. B. Leach, of Taunton, Mass., be placed on our roll as an honorary member of this Association. (Adopted unanimously.)

The President—We are happy to welcome Mr. Leach as an honorary member of our Association.

Mr. Leach—Mr. President, and gentlemen of the Western Association, I feel that I am entirely unworthy the honor you have conferred upon me, nevertheless I accept it with a great deal of pleasure, and thank you in all sincerity for your kind words and generous action.

Mr. B. E. Chollar, of Topeka, Kansas, then read his paper on

THE RELATIVE VALUE OF GASEOUS FUELS.

In the following estimates of value, common bituminous coal at \$3.00 per ton of 2,000 pounds has been taken as a basis of comparison, and the gaseous fuel considered wholly as an article of merchandise for general sale and distribution, and not as an adjunct for use in metallurgical or other manufacturing purposes.

While the term fuel in a general sense includes everything suitable to be burned for the purpose of producing heat, and covers a great variety of substances, yet the elementary kinds of fuel are only two in number—carbon and hydrogen. The value of a fuel as such will depend, therefore, upon its composition in respect to those elements.

The calorimetric value of hydrogen is 62,000 British heat units; that is to say, the perfect combustion of one pound of hydrogen will produce sufficient heat to raise the temperature of 62,000 pounds of water 1° F.

This value is the extreme limit, and is obtained only where the vapor of combustion is condensed into the form of water and its latent heat included in the estimate.

In the great majority of practical operations, however, the products of combustion pass off at a temperature considerably higher than that of boiling water, carrying with them latent energy to the amount of about one-sixth of the total fuel value of the hydrogen; therefore, 52,000 heat units will fairly represent the heat equivalent of hydrogen when burning it, and 62,000 when decomposing water.

The calorimetric value of carbon with perfect combustion is about 14,550 heat units; when burned to carbonic oxide, 4,450; of carbonic oxide, completely burned, 4,325. The heating power of carbon in the form of carbonic oxide is equal to the difference between its value when burned to carbonic acid and to carbonic oxide, and may be taken at 10,100 heat units per pound.

The analysis of 18 kinds of English gas coal gave an average of 82.2 per cent. by weight of carbon and 5.31 of hydrogen; but since it is probable that about one-fifth of the hydrogen will be combined with oxygen, and consequently have no heating value, only 4 per cent. by weight will be herein considered.

The computed heating power of coal can be represented in round numbers by $(.80 \times 14,550 =) 11,560 + (.04 \times 52,000 =) 2,080 = 13,640$ heat units per pound. Of this total, 11,560 heat units, or 84.75 per cent., is due to the carbon, and 2,080, or 15.25 per cent., to the hydrogen.

Since, therefore, the coal by hypothesis is worth \$3 per ton, $.8475 \times \$3 = \2.54 will represent the value of the carbon, and $.1525 \times \$3 = 46$ cents, the value of the hydrogen in a ton, the value of the carbon by weight will be $\$2.54 \div .80 = \3.175 per ton, and that of the hydrogen $46 \text{ cents} \div .04 = \11.50 per ton.

If we multiply 80, the number of pounds of hydrogen in a ton of coal, by 189.251, the number of feet of hydrogen in a pound, we have 15,140, representing the number of cubic feet of hydrogen in a ton of coal; and since this quantity of hydrogen is worth 46 cents, $46 \div 15,140 = 3.04$ cents, represents the value of hydrogen per thousand feet as it exists in the coal. The heating power of hydrogen per foot when burned to water is $62,000 \div 189,251 = 317\frac{1}{2}$ heat units, and when burned to steam $52,000 \div 189,251 = 275$ heat units. If we divide 3.04, the value of hydrogen in cents per thousand, by 275, the number of thousands of heat units per thousand feet, we obtain the constant .01105, expressing the ratio between the heat units per foot and the fuel value per thousand.

Although carbon in a free state is known only as a solid, yet, for hypothetical purposes, we may consider it as a gas. In such form its density would be .82995, air being 1; the weight of a cubic foot, .062349 pounds; feet per pound, 15.824; computed specific heat = $3.40 \div 12 = .283$. Making no allowance for loss of heat in converting it into gaseous form, it would have 920 heat units per foot, and its fuel value would be 10.17 cents per thousand.

The quantity per ton of coal is represented by $1,600 \times 15.824 = 25,318$ cubic feet.

The total quantity of hydrogen and carbon per ton of coal is $25,318 + 15,140 = 40,458$ cu. ft.; the total weight, 1,680 pounds; density of the mixture, .545; weight per foot, .041525 pounds; cubic feet per pound, 24.08.

Its composition by volume is 62.58 per cent. carbon and 37.42 per cent hydrogen. Its heating value is $(.3742 \times 275 =) 102.90 + (62.58 \times 920 =) 575.74 = 678.64$ heat units per foot, and its value $649 \times .01105 = 7.50$ cents per thousand.

According to Wanklyn's Hand Book, a ton of coal of average quality may be expected to produce about as follows by weight:

Gas.....	16.5 per cent.,	or 330 pounds	per ton.
Tar.....	5.5	"	110 " "
Liquor.....	8.0	"	160 " "
Coke.....	70.0	"	1,400 " "
	<u>100.0</u>		<u>2,000</u>

An analysis of coal gas of weight similar to the foregoing, quoted by Dr. Kidder, of Boston, gave by weight and volume:

Hydrogen.....	5,000 feet	26.42 lbs.
Marsh gas.....	3,800 "	160.31 "
Carbonic oxide.....	550 "	40.58 "
Illuminants (estimated as C ₆ H ₆).....	400 "	82.23 "
Nitrogen.....	200 "	14.82 "
Oxygen.....	50 "	4.22 "
	<u>10,000 "</u>	<u>328.58 "</u>

The density is .431; 30.45 cubic feet will weigh a pound. Its calculated heating power is 680 units per foot, as follows:

Hydrogen.....	.50	$\times 275 =$	137
Marsh gas.....	.38	$\times 1006 =$	382
Carbonic oxide.....	.055	$\times 320 =$	17.5
Illuminants.....	.040	$\times 3655 =$	143
			<u>679.5</u>

Its heating value is $680 \times .01105 = 7.51$ cents per 1,000, or practically the same as we found it when the whole substance of the coal was supposed to have been converted into gas.

Dr. Letheby gives the following as reliable for an average sample coal tar, by weight:

Carbon.....	86	per cent.
Hydrogen.....	7	"
Oxygen.....	6.5	"
Sulphur.....	0.5	"
	<u>100</u>	"

Making no allowance for oxidized hydrogen, we find its heating power to be 16,153 units per pound.

$.86 \times 14,550 =$	12,513
$.07 \times 52,000 =$	3,640
	<u>16,153</u>

By multiplying the heat units per pound by .00022, we get the value in dollars per ton. Its heating value is, therefore, \$3.55 per ton.

The composition of the liquor will be about as follows:

Water.....	143.72 lbs.
CO ₂	5.79 "
H ₂ S.....	4.49 "
NH ₃	6.49 "
	<u>160.</u> "

With what may be considered a fair quality of gas coal the purifiers will remove about 2 per cent. by volume of carbonic acid, and 1 per cent. of sulphureted hydrogen; or—

CO ₂ — 200 ft. =	23.18 lbs.
H ₂ S — 100 ft. =	8.98 "
	<u>32.16</u> "

Arranging the foregoing partial products with reference to their components, we will have—

	Gas.						
	Feet.	Feet per lb.	Lbs.	Lbs. H.	Lbs. C.	Lbs. O.	Lbs. N.
Hydrogen.....	5,000	189.251	26.42	26.42
Marsh gas.....	3,800	23.704	160.31	40.08	120.23
Carbonic oxide..	550	13.552	40.58	17.39	23.19
Illuminants.....	400	4.865	82.23	6.32	75.91
Nitrogen.....	200	13.499	14.82	14.82
Oxygen.....	50	11.858	4.22	4.22
		<u>10,000</u>	<u>328.58</u>	<u>72.82</u>	<u>213.53</u>	<u>27.41</u>	<u>14.82</u>

	Liquor.						
	Feet.	Lbs. per Foot.	Lbs.	Lbs. H.	Lbs. C.	Lbs. O.	Lbs. N.
Water.....	143.72	15.97	127.75
CO ₂	50	8.624	5.79	1.57	4.22
H ₂ S.....	50	11.140	4.49	.26	4.23
NH ₃	6.00	1.06	4.94
			<u>160.00</u>	<u>17.29</u>	<u>1.57</u>	<u>131.97</u>	<u>4.94</u>

	Removed in Purifiers.						
	Feet.	Lbs. per Foot.	Lbs.	Lbs. H.	Lbs. C.	Lbs. O.	Lbs. N.
CO ₂	200	8.624	23.18	...	6.32	16.86
H ₂ S.....	100	11.140	8.98	.53	8.45
			<u>32.16</u>	<u>.53</u>	<u>6.32</u>	<u>16.86</u>	<u>8.45</u>

Tar, 110 pounds; H., 7.70; C., 94.60; O., 7.15; S., .55. Collecting and tabulating the partial products, we have for the total products of a ton of coal:

	Pr. Ct.	Pounds.	H.	C.	O.	N.	S.	Ash.
Gas	16.5	328.58	72.82	213.53	27.41	14.82
Tar	5.5	110.00	7.70	94.60	7.1555
Am. liquor	8.0	160.00	17.29	157	131.97	4.94	4.23
Removed in purifiers	1.5	32.16	53	6.32	16.86	8.45
Coke	68.5	1,369.26	1,271.49	11.77	86.00
	100.0	2,000.00	98.34	1,587.51	183.39	19.76	25.00	86.00

This analysis, although got at in a practical sort of way, is probably pretty nearly correct. It accounts for the full weight of the coal, and indicates its composition to be approximately as follows :

Carbon	80.0 per cent.
Hydrogen	5.0 "
Oxygen	9.0 "
Nitrogen	1.0 "
Sulphur	1.5 "
Ash	4.5 "
	100.0 "

The proportion of ash is rather small ; but since the oxygen is correspondingly high, the sum of the two is not greatly too much.

If we allow 272 pounds of carbon as sufficient for distilling the coal, we will have an even thousand pounds of residual coke.

In heating value, we get from the coal :

10,000 feet gas, at 7.51 cents	\$0.751
110 pounds tar, at \$3.55 per ton195
1,000 pounds carbon in coke, at \$3.17 per ton	1.585
	<u>\$2.531</u>

or 84 per cent. of the total value of the coal.

If we estimate the tar at what is at present a fair cash value—\$10 per ton—and the ammonia at 5 cents per pound, we will get a better showing, as follows :

10,000 feet gas, at 7.51 cents	\$0.751
110 pounds tar, at ½ cent55
6 pounds ammonia, at 5 cents30
1,000 pounds carbon in coke, at \$3.17 per ton	1.585
	<u>\$3.186</u>

or 18 cents more than the estimated value of the coal.

In order to convert solid carbon into a combustible gas it must be partially burned. In making water gas, advantage is taken of the fact that steam in the presence of carbon at high temperatures (1,800° F., or thereabout) gives up half its volume of oxygen to the carbon, producing a gas composed theoretically, by volume, of one-half hydrogen and one-quarter each of oxygen and carbon ; or by weight, 1 part of hydrogen to 6 of carbon and 8 of oxygen.

Supposing the process to be conducted without loss of heat, 9 pounds of water (consisting of 1 pound of hydrogen and 8 of oxygen) will combine with 6 pounds of carbon to form 15 pounds of water gas.

The quantity of heat required to decompose 9 pounds of water is the same as that produced by the complete combustion of 1 pound of hydrogen, or 62,000 heat units ; but the burning of the 6 pounds of carbon to carbonic oxide will furnish $6 \times 4,450 = 26,700$ of these. At this rate, in order to get 62,000 units we must burn $62,000 \div 26,700 = 2.322$ times 6 pounds, or 13.93 pounds of carbon. Of these 13.93 pounds of carbon, 6 pounds will have become a part of the 15 pounds of water gas, and the remainder (7.93 pounds, with 1.33 times its weight, or 10.58 pounds of oxygen and 3.356 times the weight of the oxygen, or 35.51 pounds of nitrogen from the air) will have been formed as producer gas.

The weight of the water gas is .039536 pounds per foot, or 39.536 pounds per 1,000, as follows :

	Feet.	Lbs. per Ft.	Lbs.
Hydrogen	500	.005284	2.642
Carbon	250	.063249	15.812
Oxygen	250	.084327	21.082
			<u>39.536</u>

Its density compared with air is $.039536 \div .076182 = .519$; and its weight 25.29 feet per pound. Its heating power is, hydrogen ($275 \times .5$) = 137.5 + carbon ($320 \times .5$) = 160 = 297.5 heat units per foot, and its value $297.5 \times .01105 = 3.29$ cents per 1,000.

Since 13.93 pounds of carbon furnished material for 15 pounds water gas, our residue of 1,000 pounds should represent a yield of $(15 \times 1,000) \div 13.93 = 1,077$ pounds, or $25.29 \times 1,077 = 27,237$ feet, or 54,474 feet per ton.

The composition of the producer gas resulting from the decomposition of the water required for 1 pound of hydrogen is :

Carbon	7.93 lbs.	15.824 ft. per lb. = 125.48 cu. ft.
Oxygen	10.58 "	11.858 " " 125.48 "
Nitrogen	35.51 "	13.50 " " 479.38 "
	54.02 "	730.34 "

Its weight is $730.34 \div 54.02 = 13.52$ feet per pound, and its density $13.126 \div 13.52 = .975$. Its weight per foot is .074277. Its composition by volume is :

Carbonic oxide3436
Nitrogen6564

Its heating power $.3436 \times 320 = 110$ heat units per foot, and its value 1.22 cents per 1,000.

Our 13.93 pounds of carbon has furnished combustible material not only for 54.02 pounds of producer gas, but also for the water gas. At this rate, the 1,000 pounds of residual coke from a ton of coal will produce $(54.02 \times 1,000) \div 13.93 = 3,878$ pounds, or $13.52 \times 3,878 = 52,431$ cubic feet, or 104,862 feet per ton. If it were possible, therefore, completely to convert the carbon into water gas and producer gas, without loss of heat, the total product from a ton valued at \$3.17 would be :

2,153 lbs., 54,474 ft. water gas, at	3.29 cts. per 1,000	\$1.79
7,756 " 104,862 " producer gas, at 1.22 " "		1.28
		<u>\$3.07</u>

The density of the mixture would be .808, and its weight 16.24 feet per pound. Its composition by volume would be :

Hydrogen	17.00 per cent.
Carbonic oxide	39.66 "
Nitrogen	43.34 "

Its computed heating power is 173.66 heat units per foot—

Hydrogen17	$\times 275 = 46.75$
CO3966	$\times 320 = 126.91$
		<u>173.66</u>

and its value, $174 \times .01105 = 1.92$ cents per 1,000.

In practice it is impossible even to approximate the foregoing results. In the present condition of the art of water gas making, a yield of 40,000 feet of water gas, together with 80,000 feet of producer gas per ton of coke, would probably be considered not unsatisfactory.

At this rate the value of the product would be \$2.30 per ton, as follows:

40,000 feet water gas, at 3.29 cents, =	\$1.32
80,000 feet producer gas, at 1.22 " =	.98
	<u>\$2.30</u>

or a total return of 77 per cent. of the energy of the coal, of which 44 is in the water gas and 33 in the producer gas. The producer gas is too poor in quality to sell, too good to throw away, and there is too much of it for fuel for distilling its corresponding quantity of soft coal. Our associate, Mr. Walton Clark, proposes and has adopted the latter use for it, and it is quite probable that he will find it as satisfactory as any other way of getting rid of it. For this purpose the quantity required would be equivalent to about 300 pounds of coke per ton of coal used, representing a value of about 50 cents.

The return from a ton of carbon or its equivalent might be reasonably expected to be about—

40,000 cu. ft. water gas, at 3.29.	\$1.32
Fuel (for all purposes)68
	<u>\$2.00</u>

or in round numbers two-thirds of the value of the original material.

Illuminating water gas composed as follows would not be considered a bad article :

Hydrogen	45 by volume.
CO	40
Illuminants (C ₂ H ₄)	15
	<u>100</u>

Such a gas would have a density of .563; weight .0429129 per foot, and 23.33 feet per pound. Its heating value would be 471 heat units per foot.

Hydrogen45	$\times 275 = 123.75$
CO40	$\times 320 = 128.$
C ₂ H ₄15	$\times 1463 = 219.$
		<u>470.75</u>

and its heating value $471 \times .01105 = 5.20$ cents per thousand.

Crude petroleum contains approximately 84 per cent. by weight of

carbon and 14 of hydrogen, or something like C_7H_{14} . It is not improbable, by careful distillation, that it might yield nine-tenths of its weight of a gas of about the density of ethylene (C_2H_4).

One foot of the gas would contain one foot of carbon and two of hydrogen. Its density would be .96173; weight of a foot, .073813 lbs., and 13.547 feet per pound.

Its heating power would be 1463 heat units per ft.

1 foot carbon	913 units.
2 feet hydrogen	550
	1463

and its value $1463 \times .01105 = 16.17$ cents per thousand.

In estimating the fuel value of natural gas, if we consider it composed of nine-tenths marsh gas, and the remainder a diluent, we will be not far from right.

One foot of marsh gas contains one-half foot of carbon and two feet of hydrogen; its density is, therefore, .55365; weight, .042187 lbs. per foot, and 23.704 feet per pound.

Its computed heating power is 1006 units per foot.

Carbon	$\frac{1}{2} \times 913 = 456$
Hydrogen	$2 \times 275 = 550$
	1006

and its computed heating value, $1006 \times .01105 = 11.12$ cents per thousand.

The heating power of an average sample of natural gas would be, therefore, $1006 \times .9 = 905$ units per foot, and its value $905 \times .01105 = 10$ cents per thousand.

A foot of benzine vapor (C_6H_6) contains 3 feet of carbon and 3 of hydrogen. Its heating power is 3564 units per foot.

Carbon	$3 \times 913 = 2739$
Hydrogen	$3 \times 275 = 825$
	3564

and its value, 39.4 cents per thousand.

A foot of naphthaline vapor ($C_{10}H_8$) contains 5 feet of carbon and 4 of hydrogen. Its heating power is 5665 units per foot.

Carbon	$5 \times 913 = 4565$
Hydrogen	$4 \times 275 = 1100$
	5665

and its fuel value, $5665 \times .01105 = 62.6$ cents per thousand feet.

One foot of acetylene contains one foot each of carbon and hydrogen. Its heating power is, therefore, $913 + 275 = 1,188$ units per foot, and its value $1,188 \times .01105 = 13.13$ cents per thousand.

The foregoing comparisons are based upon the theoretic calorific values of carbon and hydrogen, and will agree fairly well with results obtained by experiment. The commercial value of the gases is quite a different matter, and depends entirely upon the useful effects that can be got out of them in practice.

One-quarter of a foot of common coal gas contains energy enough to boil a pound of water. We can do the work in practice with half a foot; while to start a fire and do it with coal probably not less than a pound of it will be required. The heat energy of the coal is 50 times that of the gas, and the gas would be cheap at the cost of a corresponding quantity of coal.

On the other hand, if we were to boil a ton of water with gas it would be difficult to increase the rate of efficiency above 75 per cent., or to use less than 750 feet; whereas, 50 pounds of coal, costing $7\frac{1}{2}$ cents, would be sufficient.

In generating steam with natural gas as fuel, the evaporative duty under favorable conditions has been as high as a pound of water for 1.35 feet of gas; or an efficiency of 80 per cent. of the energy of the fuel. With coal an evaporative duty of 12 pounds of water per pound is not at all uncommon, and 8 to 10 ought reasonably to be expected.

An average of 12 different trials with common boilers, mentioned in Box's Treatise, gives 7 pounds as the quantity of water evaporated to steam at working pressure per pound of coal consumed. This represents an efficiency of about 50 per cent.

In his work on warming buildings, Mr. Hood gives as a fair duty for hot air furnaces, 322,000 feet of air heated $1^\circ F.$ with a pound of coal. This represents a utilization of about 6,800 heat units per pound, or an efficiency of 50 per cent.

Hood (page 292) mentions a practical case where 536,000 feet of gas was heated $10^\circ F.$ with 225 feet of coal gas without a flue. The

quantity of coal required to do the same work was 16 pounds. With the flue the gas did about half the above work, or 225 feet represented 8 pounds coal.

The air in a room can be warmed with an incredibly small consumption of gas, particularly if the required quantity is burned rapidly and the products of combustion are not permitted to escape; whereas, in order to warm the whole building and provide for heat lost by radiation and ventilation, the consumption of gas would be so great that only a nominal price could be afforded.

In estimating the value of gaseous fuel where large quantities of heat at low temperatures are required, it is neither safe nor prudent to underestimate the value of coal by taking it at anything like 15 or 20 per cent. of its efficiency, while we see it in every day practice developing fully 50 per cent. of its energy.

For such purposes, if we consider the value of the fuel to be enhanced 50 per cent. by reason of its gaseous condition, and again doubled on account of its convenience and other advantages, we shall probably be within reasonable bounds. In other words, coal gas at 25 cents, or plain water gas at something more than 10 cents per 1,000, might find market for general domestic fuel purposes.

Although the computed value of coal gas is in round numbers about $2\frac{1}{2}$ times the value of water gas, it is by no means certain that its practical value is the same.

Investigations in regard to radiation of heat at high temperatures have shown that the rate increases enormously with increase of temperature. By applying a formula that had been found rigidly correct up to temperatures of about 600° , Mr. Box estimated that while the radiation at $1,860^\circ$ was represented by 300, the loss of heat at $2,580^\circ$ was 4,600. Now, since the flame temperature of water gas is considerably higher than that of coal gas, it is not unreasonable to expect it to develop a higher rate of practical efficiency.

The advent of natural gas has brought the question of fuel gas with it; it has come to stay with us, and it is a problem to be solved.

For cooking and similar purposes we have seen that gas is cheap at 50 times its assay value, while for warming and manufacturing purposes it might be dear at one-tenth of that rate.

Our customers are now as well satisfied with gas at \$1.50 per 1,000 for present uses as they would be at 25 cents for general purposes. If we attempt to supply the latter market, we must necessarily lose the former.

It would appear, therefore, that if we are unable successfully to compete with the grand laboratory of nature, we can at least keep abreast with the times in improvements, use up our material to the best advantage, make the best gas possible and sell it at the lowest price possible, and leave the rest to our customers.

Discussion.

The President—You have heard the very valuable and practical paper that was read by Mr. Chollar, and it is now before you for consideration and discussion. We shall be glad to have any member who has anything to contribute, either in furtherance of the claim made by Mr. Chollar, or in opposition, to present his views.

Mr. Walton Clark—I have made some few calculations on calorific values, and know the labor involved in them, and I am lost in admiration at the patience which Mr. Chollar has exhibited in this work. It is impossible for a man who has not attempted anything of the sort to appreciate the amount of labor involved in the preparation of the few pages which he has read to us. It is impossible at such short notice to criticise Mr. Chollar's statements. To go over these figures and verify them, as it would be necessary to do before any intelligent criticism could be made, would require the labor of days. Without wishing to depreciate the value of any part of the paper, I would state that what strikes me as particularly happy in it are the first and second paragraphs on page 9. I think those observations state the possibilities of fuel gas very correctly and very tersely. They mark the fact that while there is a large market for fuel which fuel gas can not hope to reach, yet there is another market that is simply waiting for it. I cannot say that I concur in or differ with Mr. Chollar in his conclusions, as it is impossible without a further and more careful reading of the paper and a consideration of the conclusions which he deduces, to make any intelligent criticism upon it.

Mr. Lansden—I would like to ask Mr. Chollar this question: Is the estimate of the value of fuel gas for domestic uses based on the difference in value between illuminating gas and a fuel water gas, or a fuel gas uncarbureted? What would be the relative value in price to the consumer of the same results in a gas cooking stove?

Mr. Chollar—The two gases will have their own value in respect to their composition, and they would have another value in practical use.

Mr. Lansden—I supposed Mr. Chollar had worked the matter up so that he could tell us. The matter is interesting to most of us in this way: We want to know whether we shall furnish a gas to our consumers which shall be at the same time a fuel and an illuminating gas, or whether we shall have to lay extra pipes and supply water gas?

Mr. Chollar—My personal opinion would be that the illuminating gas would be the one thing needed. According to my estimate of the value of water gas or producer gas, the latter would hardly be worth distributing for general use unless it was carbureted, as the heat comes mostly from the carbon that is not oxidized.

Mr. Dunbar—Have you any idea that it is practicable to manufacture a gas which can be used at the same time both for illuminating purposes and for fuel purposes?

Mr. Chollar—I have a very slight idea about it.

Mr. Dunbar—You can form an opinion?

Mr. Chollar—You can base your own opinion upon the figures themselves. I have not given an opinion in the whole paper.

Mr. Dunbar—But I would like to know what your opinion is, if you have one.

Mr. Chollar—Give me the question again, directly, and I will give you an answer.

Mr. Dunbar—My question is, will an illuminating gas, such as we are now producing, be used as a fuel gas in future, or will a separate gas be manufactured and used for fuel purposes.

Mr. Chollar—My opinion is that no fuel gas can be generally sold that is not also an illuminant.

Mr. Dunbar—That is just what I want to know. I thought my question covered that ground.

Mr. Judge—I do not think that the gentleman answered Mr. Lansden's question as he intended it, or at least as I understood it. I think that what he intended to ask was, for instance, with an illuminating gas at \$1.50 per 1,000, what would hydrogen gas be worth? That is what I would like to learn from Mr. Chollar, if he can answer the question.

Mr. Chollar—I do not clearly understand your question.

Mr. Judge—I ask, what relative value hydrogen gas must have as compared with coal gas? Supposing that coal gas as an illuminating gas can be sold at \$1.50, what price would you set on straight hydrogen gas giving the same heat?

Mr. Chollar—Coal gas is worth a little more than double what hydrogen is worth.

Mr. Lansden—I think that he misunderstands the exact point. Of course we cannot distribute pure hydrogen through the streets. The practical question before us is this: Suppose we can furnish the consumer a non-burning gas to illuminate his house which is worth \$1.50 per 1,000, and which can be sold for that, at what price can we sell an uncarbureted fuel gas which shall compete?

Mr. Chollar—I have not considered that subject at all.

Mr. Lansden—What is the value to the consumer of non-carbureted gas as compared with carbureted gas?

Mr. Chollar—Non-carbureted gas assays 3.29 cents per 1,000 feet, and coal gas at 7.5 cents, in actual heating power. What it can be sold for I have not considered.

Mr. Lansden—I take it that the value of the heating property is quite different.

Mr. Chollar—I figure it at 3.29 as against 7.5.

Mr. Forstall—As Mr. Chollar says, the heating value of coal gas would be about 2½ times the value of water gas. Or, if you sell the illuminating gas at \$1, the value of the non-carbureted gas would be 40 cents per 1,000.

The President—I think Mr. Lansden's question has hardly been answered yet. As I understand his question it was this: He desires to know what would be the proportionate value in practice, so far as the heating qualities of an illuminating or a non-carbureted heating gas are concerned.

Mr. Chollar—That would have to be determined by experiment. I have no idea.

Mr. Egner—I would like to say a few words on that point. If the gentleman will wait for three or four months that question will be determined for him, and it will not cost him one cent. We have a works and about 38 miles of mains in St. Louis which will soon become practically useless as conveyers of illuminating gas, and Mr. McMillin (who unfortunately is not here) has instructed me to convert those works into fuel gas works. The thing is going to be done, and an attempt will be made to distribute fuel gas on a large scale. The whole country will then know whether it will be a failure or a success. I am sorry Mr. McMillin is not here to speak for himself.

Mr. Lansden—The question I would like to have answered is this:

Have we to go before our consumer with two kinds of gas, or can we say to him we will furnish a gas at \$1 per 1,000 feet which will furnish both light and heat to his building? Can you do that with any non-carbureted water gas which is known to-day? At what price can you furnish such a gas—a gas which will give the consumer both illumination and heat? I want to get at the value of such a gas in dollars and cents.

Mr. Chollar—I think it would have to be so low that nobody could afford to make it.

Mr. Dunbar—The value of coal gas is put at 2½ times that of water gas. Then the paper states that the flame temperature of water gas is considerably higher than that of coal gas. That would bring the proportion down about how much?

Mr. Chollar—I did not make any calculation on that at all.

Mr. Somerville—This paper is certainly a very valuable one, but it seems impossible that we can discuss it properly, because it contains so many figures and calculations that we shall require time to study them over in order that his conclusions may be made plain. We cannot do it justice here this evening. But I would, however, like to draw your attention to one thing we ought to think over when we talk about fuel gas. Mr. Chollar says, on page 9: "Hood (page 292) mentions a practical case where 536,000 feet of gas was heated 10° F. with 225 feet of coal gas without a flue. The quantity of coal required to do the same work was 16 pounds. With the flue the gas did about half the above work, or 225 feet represented 8 pounds of coal." This is where we have to be cautious about the figures in a theoretical discussion of the value of water gas. The flue is the great trouble. The only safe solution to this question is that which will be furnished in Mr. Egner's report of what he is able to do with his fuel gas works. I regard all this talk about the efficiency of a gas being 70 to 80 per cent. as perfect nonsense. We have never got at the real efficiency of gas, and never will get at it, because of the very fact that you must carry the products of combustion out of the room, and with these products of combustion is carried nearly 50 per cent. of the heat in the fuel.

On motion of Mr. Egner a vote of thanks was tendered to Mr. Chollar for his paper.

IN MEMORIAM PROCEEDINGS.

EULOGIZING EX-PRESIDENT EDWARD J. KING.

The President—The next business before the meeting will be the reading of the eulogy upon our departed Ex-President and friend, Mr. Edward J. King, which will be presented by Mr. George G. Ramsdell.

Mr. Ramsdell's tribute was as follows:

When the gardener, passing in and out among his plants and flowers, culls one here and plucks one there, we question not his motive or wisdom, our comprehension being capable of discerning his tender love and interest, too genuine and sincere to admit of other than the most affectionate treatment. When the "Great Reaper, with His sickle keen," invades our circle, cuts down from among our number one we love, one whose early manhood gives promise of a well-rounded, useful life, finite minds fail to discern the motive or wisdom, and we stand lost in wonder and awe. We are startled into an appalling consciousness of man's transitory, uncertain existence; we stand face to face with the mystery of death, vainly seeking for some solution of the dark problem. Such, no doubt, was the general feeling when the unwelcome news was received that our friend, Edward J. King, had left us.

It is fitting that, before our meeting adjourns, we honor the memory of this friend, whose vacant chair is eloquent of the irreparable loss we have suffered, by giving some expression to the loving remembrance in which we hold him. Yet I approach the task with timidity born of my sense of inability to do justice to the noble character of "Ed." J. King.

There are many good men and true in our fraternity—indeed we think no better men can be found than those composing the Western Association; and our late President was conspicuous in its ranks, not only because of his honored position, but because he possessed those enduring qualities of mind and character which made the world better for his being in it.

I will give but a slender outline of his life and pursuits, as you are all familiar with his career.

He was one of the finest types of that modern creation known as the "Western man." Born in Jacksonville, Ill., in 1847, he came into a heritage of enterprise, energy and public spirit, which characterizes the sons of western pioneers, and in early youth gave promise of those distinguishing traits which mark the man of talent. We who knew him in mature manhood, full of ripe power, know that, more than most men, he realized all youthful ideals, and became a successful man, in the best meaning of the term.

Having supplemented a public school education with scientific courses in Illinois College, and in a Polytechnic school in Philadelphia, he brought to the gas profession a mind well trained to scientific thought, and an enthusiasm which never failed. In the many difficult problems which confront the gas engineer, his motto was "Excelsior." He was always a student, deeming no labor lost which was expended for the searching out of some truth which would benefit his profession. Though not despising the comfortable assurance that the balance was on the right side of his ledger, he looked above and beyond the mere material success to be attained in his profession, and was ever working in the interest of science.

Among America's gas engineers he stood well to the front, and his life of constant activity and faithful work in his chosen profession should be an inspiration to all gas men.

Not alone in the science of gas making was our friend recognized as a master mind, but also in other pursuits which engaged his attention he was pre-eminent for clear intelligence and sound judgment. To his energy and zeal for the public welfare, his native town owes the telephone system and electric lighting. He was one of the originators of the Business Men's Association, and its effective Secretary from its organization; President and actively interested in the Jacksonville Manufacturing Company; a Director in the Security, Building and Loan Association; a stockholder and director in the Jacksonville *Journal* Company; an efficient member of the fraternities of the Masons, Pythians, Odd-Fellows, United Workmen, and his college society, Phi Alpha.

Surely, without mentioning church or social duties, this was a busy life, and affords a striking example of the tendency to overload those who, after successfully managing their own affairs are too philanthropic and public spirited to refuse assistance to others less qualified. Naturally of a buoyant, progressive, temperament, he became a shining target for the ballot. To be identified with a society was to be pressed forward to its head, each step assuming new responsibilities, each bearing its quota of new duties. There are those who possess the happy faculty of enjoying official honor, and escaping its labors; but "Ed." King was not of that mold. Official life to him was a painstaking, conscientious service, involving thought and effort, until he had acquitted himself honorably, and could with a just pride relinquish the mantle of authority to his successor.

But, after all, it is not these recitals of his attainments that bring up before us the whole-souled, generous man, whose noble, frank countenance is absent to-day. It is when we speak of his social qualities, of his virtues, that he seems nearer to us, not wholly lost.

No manlier man, no truer friend, no better citizen ever passed beyond our view than our genial comrade and co-worker whom we mourn to-day. In him was that rare combination, that union of strength and gentleness which endeared him to all. His life's drama was not one of startling action, yet in deeds of quiet usefulness, in unselfish devotion to duty, it was not the less heroic; and who doubts the lasting influence for good such a life has left behind it? The world has lost a useful man, one of high aspirations and noble aims, one who lived purely.

In his home, which is the synonym for gracious hospitality, one saw him at his best. Who that has there received his sincere welcome, looked into his candid eyes, and felt the strong grasp of his hand, will ever forget Edward J. King?

He needs no tribute from any pen to perpetuate his memory. His good fame lives in the hearts of his friends. "His works do follow him."

He was modest and unassuming, yet withal a man of strong individuality, who gave the impression of reserved force. He had strong convictions as regards religion, and his daily life embodied his beliefs, yet he was notably free from those narrow ideas which too often obscure the virtues of the orthodox Christian. His was a big heart, filled with generous emotions and kindly sympathy toward all. His deeds of charity were known only to his family and intimate friends; he was not one to boast of his good actions; but many poor and unfortunate souls have reason to rejoice that "Ed." King came across their path. This was vividly apparent at the time of his death in testimony of self-evident genuineness and integrity, through the press, and in resolutions adopted by the numerous organizations wherein he had so abundantly contributed of his knowledge, judgment, skill, care and attention. Called in the flush of manhood's prime, his death enveloped in incidents of peculiar sadness, he passed away, leaving aching hearts, whose sorrow would be unbearable, but for the fragrant odor of a life unusually rich in all that goes to make a noble man.

My friends, if each of you were to bring a leaf from your own acquaintance with "Ed." King, this brief address would grow into a bulky volume, on every page of which would be recorded some noble

thought, some noble deed emanating from him whom it was our good fortune to have known and loved. Yet the beauty and significance of his life may be epitomized in the words of the poet. "He was a man; take him all in all we shall not look upon his like again."

On motion of Mr. Lansden, seconded by Mr. Scofield, the Ramsdell eulogy was ordered spread upon the record of the Association, and the Secretary was directed to send a copy to the family of Mr. King.

The President—It is good for us occasionally to lay aside the usual avocations of life, and dwell for a moment in the realm of recollection upon those who have gone before. We have with us to-day Capt. William Henry White, of New York, who had the honor and the pleasure of being an intimate friend and acquaintance of our departed brother; and I ask that he shall be permitted to place a flower of recollection upon the grave of our departed friend.

CAPT. WHITE'S TRIBUTE.

Capt. White—Mr. President and gentlemen of the Association, I came among you to-day without the slightest idea that you would make such a demand upon me; and yet who can refuse to do his part towards perpetuating the memory of so gracious an associate, and so genial a man, as was our late President, Mr. King. While I question somewhat the wisdom of interrupting the business proceedings of such a gathering as this for the purpose for which you have just ceased your labors, yet, like all rules, that, too, has its exceptions; and no better exception could be made than to pause for an instant to say something in recollection of that man. While my acquaintance with Mr. King is of much shorter duration than that of many of the gentlemen before me, yet in the time that I did know him I learned to appreciate his great worth as a man and his value to us as a brother engineer; and I also learned the high standard upon which he gauged his life, the standard which was the gauge not only of his daily life but of his business life and of his home life. In fact, there was no separation with him between the duties of the church on Sunday and the duties of the Christian gentleman throughout the week. Entirely unpretentious in his Christian beliefs, he lived them and carried them daily into practice. Every one of you appreciates, as I do, all the manly characteristics of this most manly man. Modest in all the affairs of life, ever ready to help either with his purse or with his advice, yet the very last man of all to press upon you any unasked for help, and the very last man who, having helped you, reminded you of the service rendered. It seems to me, Mr. President, if we can thank the active thinkers of the day for one thing more than for another, it is for the fact that they have stripped the human mind of that barbarous conception of death as a malevolent spirit stalking about the world, slaying the fairest victims and bearing them away to gloomy caverns. The grave now is looked upon not as the portal to a land of shadows and sorrows, but as the entrance to a home of lovely realities and wider knowledge and opportunity. The same sad parting may still mark our passing, but those who stand beside our grave no longer fear that annihilation has whelmed the dead friend. Rather do they stand as we look upon the loved child whom we place upon a ship and send across the ocean in search of added health and kindlier climate, there to bask in the sunshine of a brighter life, knowing full well that sometime we shall see him again, better, brighter and happier for the separation. I know to whom I speak thus. As we together recall the memory of our dead friend, each of us feels the pulsing of his own sorrows, and the years back of us speak to our hearts in voices eloquent and pathetic. Then in the kinship of kindred experience and surrounded by the memory of him we now mourn, believe with us further that somewhere in God's loving providence this dear friend to whom we have here in sorrow bade good night, will yet, with voice tuned to new sweetness, and heart and mind brightened and broadened by newer experiences, bid us good morning in some higher and better sphere of our unending life. That all of which we make seeming loss and shipwreck "upon the banks and shoals of time" will yet come safely back to us, like a ship, which, sailing away at night into the darkness and tempests of the ocean, some morning, with sails washed by the storms and incarnadined with the rising sun, comes sailing safely into port. Therefore, let us out from this tender our sacred season of recollection with our minds fixed upon the cumulation of the good we know to have been part of the earthly life of Mr. King, remembering that while it is to but few that some great deed or martyrdom is assigned, it is in the daily and unostentatious practice of amenities and virtues of life that the noblest part of our work is done and the most enduring record made. This thought I would leave in your minds symbolized as it is by the life of him whose removal from us we so regret, and may our hearts be as sweetly harmonized with the inimitable laws of God as now is the better and eternal part of him whose gracious memory we gather at this hour to keep green, and about

whose name we wreath the immortelles of loving and tender remembrance, thankful that—

“ Whether back to us they drift,
Who pass beyond our view,
Where life's celestial mountains lift
Their peaks above the blue—
God's will be done! Whose gracious will
Through all our mortal fret,
One sacred blessing leaves us still :
To love—and not forget.”

The President—If any other friends of our late President and comrade care to add a few words in memoriam we shall be glad to hear them.

TRIBUTE OF MR. SOMERVILLE.

Mr. Somerville—It is not the want of love that keeps us from talking—I know that; and it is not a lack of respect for his memory that keeps us quiet, for there is a silence which, in times like this, has in it more of eloquence than anything in words. In speaking of our departed friends the English language appears all too confined to afford a fitting expression to our thoughts, and so we find no appropriate words for the sense of loss which we carry in our hearts when we think of our departed friend and comrade, Mr. King. I am free to say that I always felt better after a fraternal interview or communion with Mr. King. Not long before his death he was at my house, and I could not but notice the power that he possessed of interesting himself with the children and of interesting them in him. They knew him and loved him. He laid aside for the time the scientific subjects in which he was so much interested, and the wonders of electricity that he knew so much about, and, joining in the prattle of the children, told them about his journey to London, and described to them the many beautiful things he had seen. To-day he is well remembered in our house. What can we do better than to follow his example? Let us try to do it. Nothing could please Mr. King better than to know that some little thing that he had done was pleasantly remembered; and I know that many of you can say with me that you always felt better after shaking hands and talking with our dear friend, King.

REPORT OF COMMITTEE ON MEMORIAL RESOLUTIONS.

Mr. J. B. Howard, from the Committee on Memorial Resolutions, read the following, which were, on motion, ordered spread upon the record:

THE KING MEMORIAL.

Edward J. King, the honored President of this Association, has been called to his final rest. In his death we, his surviving brothers, have lost a companion whom we loved and delighted to honor.

The deceased was born in Jacksonville, Ill., on the 14th day of June, 1847. His education began in the public schools of his native city, was continued through the scientific course in the Illinois College, and completed by taking a special polytechnic course in an Eastern College.

Returning to Jacksonville he engaged in mercantile business and assisted his father, the late J. O. King, in the management of the gas works. To this latter business he, after the death of his father, devoted his entire time, serving as Superintendent of the Jacksonville Gas Light and Coke Company. The acknowledged successful management of this Company by the father was transmitted to “Ed.,” as he was familiarly called, and he, by his skill, industry, and business habits proved to be in all respects a worthy son of a worthy sire.

Edward J. King was one of those who, in St. Louis, Sept. 19, 1878, organized the Western Gas Association, and from that day his interest in the Society was ever faithful. His personal influence, his eloquent voice, and his ready pen were ever active in its behalf and support. He was in fact, as we all know, untiring in his work filling well his place, whether as a private member or on the various committees, and as Second and First Vice-President, nor will we soon forget with what joyful acclaim, but one short year ago, his unanimous election as President of this Association was received.

We, his associates, then looked forward with fond anticipations to the present time, when we should hail our new and honored chief as presiding officer. Alas! he is not with us. No more will the echo of his foot resound within these walls. Nor will his pleasant voice again be heard in instruction, advice, or admonition. Never again will his genial smile and kindly glance warm up our hearts, nor the strong grasp of his friendly hand respond to ours in greeting. No, he is not with us; but his example and the memory of his good deeds remain with us.

“ Long, long be our hearts with such memories filled!
Like the vase in which roses have once been distilled,
You may break, you may ruin the vase, if you will,
But the scent of the roses will hang round it still.”

In view, therefore, of the fact that Brother Edward J. King was one of the founders of this Association, and at the time of his death was its President-elect, it is meet and proper that an expression of our appreciation of his manly qualities should be placed on record. Therefore be it

Resolved, That in the death of Brother King we are called upon to mourn the loss of one of our most worthy, upright, and intelligent members; a man of honest purposes, a true helper, full of generous and noble impulses, whose social qualities endeared him to all with whom he came in contact. He was wise in council, fearless in debate, and ever zealous in his efforts to promote the best interests of the Association. Official honors were conferred upon him in just appreciation of his eminent services. In his native city he was looked upon with pride as one of the most enterprising business men, foremost in good works, a genial Christian gentleman, whose benevolent disposition was evinced by his active membership in the church and in the several friendly and charitable societies of Jacksonville. As a good citizen he was honored when living and universally mourned when taken away. Death has robbed a happy home of its sunlight and joy. He was a devoted husband and an affectionate father. His genial, loving presence will long be missed from the family circle.

Resolved, That we tender to the bereaved family of our departed brother and co-worker our sincere condolence and sympathy, and instruct our Secretary to furnish them with a certified copy of this paper, and also that it be made a part of the records of this Association.

J. B. HOWARD,
JNO. MCILHENNY, } Committee.
JAS. SOMERVILLE, }

THE FORSTALL MEMORIAL.

“Died, in Chicago, Illinois, on the evening of the 19th day of January, 1890, Theobald Forstall, aged 54 years.” Such was the simple announcement that carried sorrow to our hearts. Although not entirely unexpected, it was feared by all his friends, for months preceding his demise, that he held his life by a very uncertain tenure; and, whilst hoping, still they feared.

Deceased was born in New Orleans, La., in 1836, and was of French lineage. At an early day he was thrown entirely upon his own resources, a perhaps fortunate circumstance, for it aroused and developed his latent power, made him the man he was, and caused his name to be known and revered wherever the art of gas making is practiced. In 1864 he accepted the position of bookkeeper of the New Orleans Gas Light Company, and shortly afterward was made General Manager of the Company. In addition he was appointed as the Company's Engineer. In 1874 he was elected to membership in the American Association, and at once took a leading stand among its brightest and best intellects. His able paper, contributed to the third semi-annual meeting (1875), on the subject of “The Proper Preparation of Lime for Use in the Purification of Coal Gas,” at once completely established in this country his fame as an engineer. He joined the Western Gas Association, in Chicago, at the meeting held in 1888, and there can be no doubt as to the fact that to his great ability and active service we owe much of the present prosperity and prestige of the Association.

As the President and General Manager of the Chicago Gas Light Company he achieved the most wonderful success. He served his employers but too well; anxiety and overwork completed the wreck of a constitution which at best was never strong, and he has paid the penalty. A great and good man has passed away, and it is fit that we should place his name as such on the records of the Association. Therefore, be it

Resolved, That in the death of Theobald Forstall our Association has lost a member whose great ability, earnest purpose and upright conduct honored us in his membership, and at all times contributed to raise the standard of the Association to the highest point of excellence, and individually we have lost a genial companion and a true friend, whose example we should all seek and labor to follow, and whose virtues we should try to imitate.

Resolved, That to the family of our deceased brother and associate we offer our tenderest condolence and sympathy.

Resolved, That this paper and these resolutions be entered upon the records of this Association and a copy thereof be presented to the bereaved family of our deceased friend and brother.

J. B. HOWARD,
JNO. MCILHENNY, } Committee.
JAS. SOMERVILLE, }

THE ARNDT MEMORIAL.

Alfred Arndt died at the Clarendon Hotel, in the city of Chicago, on the 17th day of October, 1889, aged 44 years.

Mr. Arndt was a native of Australia, but found a home and friends with the people of the United States of America, who are at all times.

quick to discover true manhood and genuine worth. He was elected a member of the Western Gas Association at the meeting held in Chicago, 1888, and at the time of his death was Engineer of the Chicago Gas Light Company, and was acknowledged to be a man of great industry and fine ability. We, his surviving companions, desiring to place upon record our appreciation of his many sterling qualities of mind and heart, and of our grief at the sad loss we have sustained by his untimely removal from his earthly field of labor, do hereby direct that this expression of our feelings be entered upon the minutes of our meeting, and that a copy thereof be sent to his surviving family, with kind assurances of our sincere condolence and sympathy.

J. B. HOWARD,
JNO. MCILHENNY, } Committee.
JAS. SOMERVILLE,

THE COSGROVE MEMORIAL.

Whereas, We have heard with much sorrow and deep regret of the death of Mr. Thomas A. Cosgrove, of Evanston, Ill.; therefore be it

Resolved, That in the death of Mr. Cosgrove, an old and valued member of this Association, we have met with a loss which we all deeply feel. The business and friendly relations we have sustained with him are closed. He has gone to his eternal rest. Living, he commanded our respect and esteem; dead, his memory will be ever cherished in that he has left behind him an unsullied name and a character free from blemish.

Resolved, That this preamble and resolutions be placed on record, and that a copy of same be forwarded to the family of deceased.

J. B. HOWARD,
JNO. MCILHENNY, } Committee.
JAS. SOMERVILLE,

THE FULLAGAR MEMORIAL.

Once again this Association is startled by the fact that death is in our midst, coming to us as a solemn warning, saying: "Be thou also ready."

Mr. John Fullagar, Ex-President of the Western Gas Association, is no more. He departed this life on Sunday, the 27th day of April last, at San Jose, Cal., where he had recently taken up his residence as Engineer and Chief of Construction of the San Jose gas works; a position which, by education and experience, he was eminently qualified to fill. As President of this Association, during the session held at St. Louis three years ago, he will be remembered for his ability, courtesy, impartial decisions and urbanity of disposition. Deliberate, thoughtful, prudent, with no effort at oratorical display, but endowed with a happy faculty of clothing his thoughts in appropriate language, he faithfully performed his every duty. Therefore,

Resolved, That, in the death of such a man as Brother Fullagar, we feel a great loss, and have reason to mourn his departure; for in all the relations of life he was faithful and true. As a husband and father, the sorrow of his bereaved widow and fatherless children who mourn his loss will abundantly testify to his love and devotion.

"Life's labor done,
Serenely to his final rest he passed;
While the soft memories of his virtues yet linger,
Like sunlight hues where that bright orb has set."

Resolved, That to the widow and children bereft in the death of Mr. Fullagar, we tender our deepest sympathy, and pray that God in his mercy may take them under his kind and protecting care.

Resolved, That these resolutions be spread upon the records of this meeting, and a copy thereof be sent to the widow of Mr. Fullagar.

J. B. HOWARD,
JNO. MCILHENNY, } Committee.
JAS. SOMERVILLE,

CALLING ATTENTION TO THE EXHIBITION OF GAS APPARATUS.

Mr. Egner—If not out of order I wish to state that an exhibition of gas apparatus is under way at the building occupied by the Laedle Gas Company, and I have been requested to invite the members to visit the exhibition, and that an especial invitation is extended to the ladies to inspect the display. It is very seldom that an opportunity is afforded to examine such a large assortment of gas stoves. Other appliances are there which will interest gas engineers.

(To be continued.)

ANOTHER example of the inutility of gasoline cooking stoves is afforded in a recent case, at Portsmouth, Ohio, of an explosion of one of these infernal devices whereby property to the value of \$50,000 was destroyed.

The Massachusetts Supreme Judicial Court Differs from Attorney General Waterman.

We gave in our issue for May 26 (page 738) the full text of the opinion of Attorney General Waterman, transmitted to the House of Representatives of Massachusetts, in response to the request of the latter for his views respecting the legal right of cities, towns, etc., of that State to engage in the manufacture and distribution of gas and electric light on municipal account. The Attorney General's opinion was adverse to the exercise of the right in question, but the House refused to accept that definition as final and thereupon appealed to the Supreme Court for a further opinion. This has since been prepared, and we give hereunder the language of the Judges, who are, as will be seen, in direct conflict with the Attorney General. Our correspondent in forwarding the "copy," introduces his subject by remarking:

In the House, on May 28, the following opinion was received from the Supreme Court in answer to the question of the House as to the constitutional right of the Legislature to enact laws conferring on cities and towns the power to manufacture gas and electric light for public use, and also for sale to their own citizens:

To the Honorable House of Representatives of the Commonwealth of Massachusetts.

We received on the 24th inst. your order of the 22d inst., a copy of which is annexed, and we respectfully submit the following opinion:

In considering the questions asked, we assume that the power to be conferred is not merely a power to receive and use property given in trust for the purposes named, but is a power to raise money by taxation, and by means of it to construct and maintain works for the manufacture and distribution of gas and electricity to be used by the municipalities for lighting the public streets and buildings, and by the inhabitants for lighting the land and buildings which are their private property. We also assume that the gas or electricity to be furnished to the inhabitants for their private use is to be paid for by them at rates to be established, which shall be deemed sufficient to reimburse to the cities and towns the reasonable cost of what is furnished, and that all the inhabitants of the cities or towns are to have the same or similar rights to be supplied with gas or electricity, so far as is reasonably practicable, and the capacity and extent of the works, which it is deemed expedient to maintain, will permit. Whether cities and towns can be authorized to give gas and electricity to their inhabitants, or to sell either of them at varying and disproportionate prices, selecting their customers, selling to some and arbitrarily refusing to sell to others, are questions which it is not necessary to consider.

By the constitution full power and authority are given to the General Court to make "all manner of wholesome and reasonable orders, laws, statutes and ordinances," not repugnant to the constitution, which "they shall judge to be for the good and welfare of the commonwealth," etc., and "to impose and levy proportional and reasonable assessments, rates and taxes upon all the inhabitants of and persons resident, and the estates lying within the said commonwealth * * * for the public service in the necessary defence and support of the government of the said commonwealth, and the protection and preservation of the subjects thereof," etc. [Part 2, Sec. 1, Chap. 40.]

The extent of the right of taxation is not necessarily to be measured by that of the right of eminent domain, but the rights are analogous. Private property can be taken without the consent of the owner only for public uses, and the owner must be paid full compensation therefor: otherwise he would contribute more than his proportionate share toward the public expenses. By taxation the inhabitants are compelled to part with their property, but the taxation must be proportional and reasonable and for public purposes. Taxes may be imposed on all the inhabitants of the State for general purposes, or upon the inhabitants of defined localities for local purposes, and when distinct private benefits are received from public works, special assessments may be laid upon individuals.

We have no doubt that if the furnishing of gas and electricity for illuminating purposes is a public service, the performance of this service can be delegated by the Legislature to cities and towns for the benefit of themselves and their inhabitants, and that such cities and towns can be authorized to impose taxes for this purpose upon the inhabitants, and to establish reasonable rates, which the inhabitants who use the gas and electricity, may be compelled to pay. The fundamental question is, whether the manufacture and distribution of gas or electricity to be used by cities and towns for illuminating purposes, is a public service.

The maintenance of public streets and buildings is a public service, and it may be reasonably necessary to light them in order that the greatest public benefit may be obtained from using them. To say nothing of

the usefulness of lighting streets as a means of promoting order and affording protection to persons and property, the common convenience of the inhabitants may require that they be lighted. Cities and thickly settled towns have for a long time been accustomed to light their public buildings and some of their streets at the public expense. If the streets and public buildings are to be lighted, the means are a matter of expediency. If the Legislature can authorize cities and towns to light their streets and public buildings, it can authorize them to do this by any appropriate means which it may think expedient. As a question of constitutional power, we can not distinguish the right to authorize cities and towns to buy gas or electricity for their use from the right to authorize them to manufacture it for their use. We therefore answer the first question in the affirmative.

The second question is one of more difficulty. It is impossible to define with entire accuracy all the characteristics which distinguish a public service and a public use from services and uses which are private. The subject has been considered many times in the opinions of the court of which we are now the justices, and *Lowell v. Boston* in 3d Mass. is a leading case. It is there said that "an appropriation of money raised by taxation, or of property taken by the right of eminent domain by way of gift to an individual for his own use exclusively, would clearly be an excess of legislative power;" that "the promotion of the interests of individuals, either in respect of property or business, although it may result incidentally in the advancement of the public welfare, is in its essential character a private and not a public object;" and that the appropriation of property for turnpikes and railroads "can only be justified by the public service thereby secured in the increased facilities for transportation of freight and passengers of which the whole community may rightfully avail itself." It is said that the essential point is that a public service or use affects the inhabitants as a community, and not merely as individuals.

It was clearly decided that "the prevention of damage by fire is one of the objects affecting the interests of the inhabitants generally, and clearly within the scope of municipal authority." [*Allen vs. Taunton*, 19 Peck, 485.] Although the protected is private property, the need of protection is felt by every owner in the city or town; the property of one may be endangered by the burning of that of another; efficient means for protecting his property cannot well be furnished by every inhabitant; and that is a necessity of common action which makes the expenditure of money for the purpose properly a municipal expense.

The maintenance of sewers and drains is a public service. One object is the preservation of the public health; but apart from this, they are a great convenience to the inhabitants, whose estates can be drained by them. It is impracticable for every owner of lands in cities and towns to construct and maintain sewers and drains exclusively on his own account; they cannot ordinarily be constructed over any considerable territory without using the public ways or exercising the right of eminent domain; they are therefore regarded as of common convenience, and are constructed at the public expense.

The furnishing of water for cities and towns for domestic use affords, perhaps, the nearest analogy to the subject we are considering. It was long ago declared that "the supply of a large number of inhabitants with pure water is a public purpose." (*Lumbord vs. Stearns*, 4 Cash. 60.) The statutes are well known which authorize cities and towns to maintain water works for supplying their inhabitants with water and the constitutionality of these statutes has not been doubted. Water cannot ordinarily be supplied to a large city or town from ponds or streams without the exercise of the right of eminent domain and the use of the public ways; every inhabitant needs water, and often the only practicable method of obtaining it is by the agency of corporations or of the municipality. The land for the public ways having been taken for a public use, it may be subjected to other public uses, but it cannot be subjected to strictly private uses without the consent of the owners of the fee when the fee remains in the abutters. There is therefore often a necessity of having water common to the inhabitants of a community which cannot well be met except by the exercise of public rights; and therefore the furnishing of water has been considered a public service.

In the case of water, as in that of sewers and drains, a portion of the service is exclusively public, and the benefit to individuals cannot be separately estimated from that of the community; but a part of the service is rendered to individuals, and the benefit of this can be separately estimated. The inhabitants are, therefore, required to pay for the water furnished for their private use, and special assessments for the use of sewers, and drains are laid upon estates especially benefited; and for the same reasons, while, in laying out highways, the expense is public, betterment assessments may be laid upon the owners of lands specially benefited.

Artificial light, perhaps, is not so absolutely necessary as water, but it is necessary for the comfortable living of every person. Although artificial light can be supplied in other ways than by the use of gas or electricity, yet the use of one or both for lighting cities and thickly settled towns is common, and has been found to be of great convenience, and it is practically impossible for every individual to manufacture gas or electricity for himself. If gas or electricity is to be generally used in a city or town, it must be furnished by private companies or by municipality, and it cannot be distributed without the use of the public streets or the exercise of the right of eminent domain.

It is not necessarily an objection to a public work maintained by a city or town that it incidentally benefits some individuals more than others or that from the place of residence or for other reasons every inhabitant of the city or town cannot use it, if every inhabitant is so situated that he can use it has the same right to use it as the other inhabitants. It must often be a question of kind or degree whether the promoter of the interest of many individuals in the same community constitutes a public service or not. But in general it may be said that in matters which concern the welfare and convenience of all the inhabitants of a city or town and cannot be successfully dealt with without the aid of powers derived from the Legislature, may be subjected to municipal control when the benefits received are such that each inhabitant needs them and may participate in them, and it is for the interest of each inhabitant that others as well as himself should possess and enjoy them.

If the Legislature is of opinion that the common convenience and welfare of the inhabitants of cities or towns will be promoted by conferring upon the municipalities the power of manufacturing and distributing gas or electricity for the purpose of furnishing light for their inhabitants, we think that the Legislature can confer the power. We therefore answer the second question in the affirmative.

We notice that the bill, a copy of which was enclosed with your order, relates to the manufacture and distribution of gas or electricity, not only for permitting light, but also for permitting heat and power. We have not considered whether the furnishing of gas or electricity, either for heat or power, can be regarded as a public service. We have confined our opinion to the questions asked, which, as we understand them, relate to the manufacture and distribution of gas or electricity solely for the purposes of furnishing light.

Note on a New Photometer, for Measuring Electric Lighting Values.

[Abstracted from a paper read by Prof. Edward L. Nichols, of Cornell University, before the American Institute of Electrical Engineers.]

The instrument which it is my purpose to describe has been designed to meet the need which exists for an instrument by means of which both the character and intensity of an illuminant can be readily determined. Existing types of the spectrophotometer may be made to give good results, but they are expensive instruments and so difficult to use that it is only in the hands of observers of considerable experience that accuracy is assured.

The new apparatus, the "horizontal slit" photometer, is, in point of fact, a spectrophotometer in which the polarizing device is entirely done

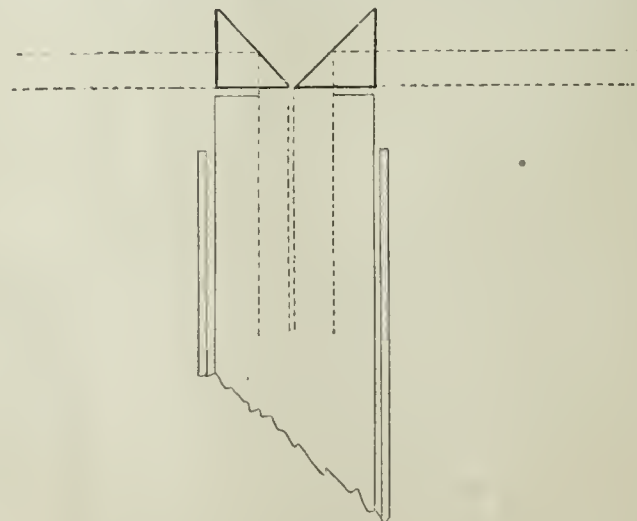

away with. In it the extremely simple principle of the Bunsen photometer is applied successively to the various regions of the visible spectra of the source of light which are to be compared. A direct vision spectroscopy of Browning's form is attached to the usual car of a Bunsen photometer, from which the disc and mirrors have been removed. The optical axis of the collimator is horizontal and at right angles to the photometer bar. The slit is horizontal and lies in a straight line joining the

sources of light which are set up in the usual manner at the ends of the bar. The bar itself is preferably of considerable length—in the case of the one upon which the original instrument under consideration was mounted, it was 500 cm. long—and should be divided into 1,000 equal parts.

In front of the spectroscope slit are placed two right angled prisms of the same size and made of the same glass (see cut). Their vertical adjacent edges bisect the slit, and light travelling from either end of the photometer bar is totally reflected by them and enters the right or left hand end of the slit in a direction parallel to the optical axis of the collimator tube.

The two sets of rays thus gathered into the spectroscope from the lights at the end of the bar are vertically dispersed by the prisms and appear in the field of view as two vertical spectra standing side by side. Equal wave lengths are in the same horizontal line and any desired region may be brought into the center of the field by an angular movement of the ocular telescope. The telescope moves along the arc of a suitably divided semi-circle, to which it may be clamped by means of a set screw. Wave lengths, corresponding to the various circle settings are determined once for all, by observation of the more prominent of the Fraunhofer lines.

When the instrument, thus mounted, is placed at the middle of the photometer bar, between lamps which are identical in intensity and quality, the two spectra are of equal brightness throughout, wave length for wave length, from red to violet. If the two lamps differ in intensity but not in quality, the two spectra will differ in brightness by the same amount from end to end, and a position may be found upon the bar for which they will be identical throughout.

Under these circumstances, which are the only ones in which the Bunsen method in photometry is strictly applicable, the instrument may be used as a simple photometer, the setting for any wave length whatever giving the candle power. For this purpose alone, viz., for the comparison of lights of similar character, the instrument offers certain manifest advantages over the various forms of the Bunsen photometer. In the course of the present paper I shall present some definite data concerning the relative sensitiveness of the two instruments when used in this way.

When the lights to be compared differ both in intensity and quality, ordinary photometric indications possess no perfectly definite significance. In this, which is the more general case, the relative brightness of the spectra of the two sources varies with the wave length. For each region of the visible spectrum, however, a position upon the photometer bar can be found at which the brightness of the two spectra in that region will be equal, and the observations thus obtained, when extended over the entire spectrum, will afford data by means of which the differences in quality of the two sources of light may be definitely expressed.

In a recent paper read before the Institute (Transactions of the American Institute of Electrical Engineers, Vol. 6, p. 135) it was stated that for a considerable range of temperature at least, the ratio between the intensities of a certain wave length of the spectrum of glowing carbon, is identical with the ratio of candle powers as determined by the Bunsen photometer.

When the wave length of this region has been established beyond question, the photometry of lights which vary in color will have been reduced to a definite scientific basis. Instead of attempting to use the Bunsen photometer in measurements to which it is not adapted, we shall be able to deduce the relative candle power of two sources of light from the comparison of a single wave length, and we shall be freed from the uncertainty arising from differences of color and from the personal errors due to the independent use of the two eyes in observation. The determination of candle power will then be an operation of precision, even when the sources of light to be compared vary widely in temperature. It is in the opportunity of performing such observations upon the photometer bar itself, under conditions which do away with many of the sources of error inherent in the usual methods of spectrophotometry, that the chief advantage of the new photometer will be found to lie.

A CORRESPONDENT at St. Louis, Mo., under date of May 29, writes: "Mr. J. T. Marsh, Superintendent of the Clinton (Mo.) Gas, Coal and Coke Company, is placing new lanterns on the public lamp posts, and—just think of it—burners rated to a consumption of 8 cubic feet of gas per hour are to be employed. The carbonizing capacity of the plant is to be increased by the addition of two benches of C's, and the condensing and purifying apparatus is to be doubled. The mains will be added to by the placing of 1½ miles of pipe. The use of gas in Clinton is rapidly increasing, and Superintendent Marsh is a very busy man just now.—A. F. T."

ITEMS OF INTEREST FROM VARIOUS LOCALITIES.

Mr. CHARLES B. HURLEY, General Superintendent of the Tacoma, Washington, Light and Water Company, has notified the residents that hereafter the Company will make no charge, on an application for a gas service, for the connecting pipes from street main to curb line. Concessions of this nature are always in order, and are always sure to result in profit.

THE suppliers of electric lighting in Paterson, N. J., evidently have determined that the practice of supplying light at a loss must be stopped, if they desire to remain in the field as an active business agent. In any event it has been determined that hereafter commercial users of the arc light must pay \$10 per arc per month—2000-candle power lamps, to run until midnight, and \$1.25 for each 16-candle power incandescent lamp for an uninterrupted service. The prior rates were: arcs, \$5 per month each; incandescents, \$1 00.

THE following is a copy of the testimonial (prepared by Messrs. Jerome Croul, Alexander Lewis and Chas. B. Lothrop, of the Detroit Gas Light Company) that has been forwarded by the Detroit Gas Light Company to the family of the late William Henry Williams, of Philadelphia, whose death was noted some time ago in the JOURNAL:

"The Directors of the Detroit Gas Light Company, believing that, when death removes a man like the late William Henry Williams, of Philadelphia, it is fitting and proper that his friends and associates should express their appreciation of his many virtues and good qualities; and believing that a good name is the best heritage, and the fact that a man has so lived as to be of aid and assistance to his fellows, admired and esteemed by all with whom he has associated, is one of the truest sources of consolation to the family circle made desolate by their loss, desire to place on record their testimonial to a well-spent life. Mr. Williams was not actively connected with the management of this Company, but his wise foresight and his sound business judgment made him the wise counsellor to whom for many years past this Company when in doubt or difficulty has turned, and never in vain. To his careful advice is attributed much of its financial success. The mental activity and clearness of perception for which he was so marked enabled him to carry in his mind the details of a large business so far from his home, and readily to solve questions that perplexed and troubled others. But those who were thus brought into business relations with him soon saw another side of his character. He seemed to possess that rare quality of making all with whom he was brought into contact feel as though they were friends of long standing, and his friendly and social manner drew all towards him by those ties of affection and regard that never come from the mere possession of business ability, however great. His unvarying kindness and courtesy, his clear and penetrating mind, and his strict honesty and uprightness of purpose, endeared him to all, and made his loss peculiarly hard to bear. His pure and upright conduct, and the fortitude and cheerfulness exhibited by him in spite of his physical infirmities from which he so long suffered, and which would have crushed one of less indomitable spirit, make his life a bright example, to be emulated by all. In his death we lose a careful and safe adviser and a true friend, whose loss to us is only less than to his family, to whom, in their great sorrow and affliction, we tender our most heartfelt sympathy. It is directed that this testimonial be spread on the records of this Company, and a copy sent to the family."

DIRECTOR WAGNER, of the Philadelphia Bureau of Public Works, has made the following awards for the supply of meters to the gas department of the service: American Meter Company, 1,800 meters, 5-light description; 240 meters (10-light) to J. J. Griffin & Co.; to the Goodwin Gas Stove and Meter Company, 144 20-light and 48 30-light meters.

THE Selectmen, of Marlboro, Mass., have officially notified the old Marlboro Gas Light Company that a franchise has been granted to the projectors of the opposition or Citizen's Gas Company. Now the Gas and Electric Light Commission of the State will have an opportunity to show its real value to vested interests.

NEWS from San Francisco is to the effect that the Supervisors have decided to recommend for adoption Supervisor Ellert's order providing for the quarterly inspection of gas fixtures in hotels, etc., and for the affixing of a card to such fixtures warning persons of the danger of blowing out the gas. The penalties for violation of this ordinance range between \$20 and \$100 fine, or an imprisonment ranging from a period of 5 days to 30 days. The great number of deaths from the accidental inhalation of illuminating gas reported during the last four years in San Francisco is the basis for this ordinance.

IN 1889 gas tar was a drug in the Lynn (Mass.) local market at the figure of \$1.50 per barrel, whereas now the demand exceeds the supply, although the rate has been advanced to \$2.50 per barrel.

THE Louisville (Ky.) Gas Company has determined to boom the local market for the sale of coke. Crushers have been purchased, and several sizes of the fuel will be kept constantly in stock. Engineer Barret has also purchased three handsome teams of Percherons, with a suitable complement of well-built drays, the appearance of which on the roads of the city cannot fail to attract attention to the fact that the Company has coke for sale.

THE Milwaukee (Wis.) Gas Light Company has awarded a contract, for a Wilkinson process and water gas plant, to Messrs. Bartlett, Hayward & Co., of Baltimore, Md. The capacity of the apparatus is fixed at one million cubic feet per diem. This plant is to include two 250 horse power Hazelton boilers, and the necessary cupolas, scrubbers, condensers, benches, blowers and exhausters. Another feature of the construction is to be a hydrogen holder, with a capacity of 100,000 cubic feet. The holder is to be constructed in and over an iron tank. Of course, new buildings will be a part of the equipment. The plant will be provided with all the latest improved appliances for mechanically handling all fuel and ashes, including mechanical stoking for the boilers, etc. It is the claim of the designers and builders that the apparatus will be so arranged that should the necessity ever arise one man in each twelve hours can perform the entire work of operation. The Wilkinson process was chosen after an extensive inspection trip, made by the President of the Company and its Engineer, Mr. E. G. Cowdery, who visited most of the larger cities where improved systems of water gas manufacture were in operation. This work will probably keep Mr. Cowdery away from the Gogebic section this summer—which is a lucky circumstance for the finny denizens of the Gogebic lakes.

WE understand that the proprietors of the new gas works, to be erected this season at Port Townsend, Washington, have determined to seal their holder in a tank built out of redwood timber. The works are to be of the 10-inch standard.

MR. JAS. BROWNLEE, Chairman of the "Committee on Proposals for Lighting the Public Lamps," Paterson, N. J., was rather disappointed over the bids received in response to his advertisement for lighting the public lamps (mixed system of arc and gas lighting) in the competition that closed last Monday. It is likely that new bids will be asked for.

THE estimate of probable cost of an electric light plant (to be operated on municipal account by the city of Milwaukee, Wis.), as returned by the Board of Public Works in response to a resolution of Common Council, is as follows—the figures being based on a plant capable of maintaining 1,745 lamps, of 2,000-candle power each: 1,745 lamps, \$47,115; 70,500 feet of conduit, \$70,500; 6,393 poles, \$22,375; 8,021 cross arms, \$1,764.62; 1,941 break arms, \$970.50; 18,000 wood pins, \$540; 15,424 bolts, \$462.72; 18,000 insulators, \$1,440; 460 miles of wire, \$84,000; 53 miles guy wire, \$636; 257,650 feet rope, \$3,145.89; 5,331 pulley blocks, \$2,398.95; 150 dozen lamp cleats, \$375; setting poles, \$6,393; cables in river crossings, \$20,000; incidentals, \$5,000; tools, \$1,000; real estate, \$20,000; buildings, \$20,000; four 500-horse power engines, \$60,000; 14 boilers, \$21,000; shafting, etc., \$20,000; 55 dynamos, \$55,000; 55 lightning arresters, apparatus, etc., \$5,000; incidentals, \$5,000; tools, \$500; total, \$575,442.18. We do not vouch for these figures; but they come from what is certainly a semi-official source.

THE authorities of St. Louis, now that public electric lighting is in vogue there, are anxious to retain the gas lamps in position at the street intersections, owing to the fact that they carry the names of said streets. They have asked the Laclede Company for a figure at which the latter will lease them to the city for street directory purposes.

SANTA MONICA, Cal., is to have a gas works; that is, if the authorities will hold out any reasonable charter inducements to the capitalists who have the project under consideration.

IN our issue of May 19th (p. 704) appears an item to the effect that the price received by the Grand Forks Gas and Electric Company, of Grand Forks, N. D., for its bonds was 80 per cent. This is an error; for the Company received par for an issue of \$80,000 worth of three-year bonds. This latter shows very much more plainly how good the credit of the Company is.

THE Laclede Gas Light Company, St. Louis, has purchased, at auction sale, the property, rights, etc., of the St. Louis Gas, Fuel and Power

Company, otherwise known as the Water Gas Company. The price paid was \$455,000.

LEWIS BALCH, Health Officer of Albany, N. Y., has called the attention of the Mayor to the dangerously defective condition of some of the distributing wires of the Albany Electric Illuminating Company.

THE proprietors of the Sioux City (Iowa) Gas Company are enlarging their cupola house, and the Kerr Murray Mfg. Company, of Fort Wayne, Ind., have engaged to furnish a wrought iron trussed roof (with slate covering) for same.

WHILE on the subject of contracts we might also note that the Kerr Murray Company has just completed, for the Jackson (Mich.) Gas and Fuel Company, a new cupola, rated to a per diem capacity of one-half million cubic feet. The same constructors will also erect a gasholder (80 ft. by 22 ft., capacity, 110,000 cubic feet) for the Butte City (Helena, Mont.) Gas Company.

OLD reliable, M. N. Diall, of the Terre Haute (Ind.) Gas Company has succeeded in putting out 97 gas stoves since March 1st. Pretty good, Mr. Diall.

MENTION of Terre Haute recalls the fact that the Stacey Manufacturing Company is to build a new single-lift holder there, the vessel to have a diameter of 80 feet.

A DESPATCH from Lowell, Mass., under date of June 1st, tells the following tale of woe: "A serious accident occurred here, Saturday night, at the electric light station in Middle street, causing the sudden extinguishing of 300 arc lights in the city. Two employees were working under the shafting when a rasping, buzzing sound warned them to fly to the next apartment. Their escape was effected none too soon, for a heavy counter-shaft, weighing two tons, fell, demolishing the dynamos. The shaft was 23 feet long, 2½ inches in diameter, and upon it hung 8 Hunter friction clutches and six belts. The damage is put at \$2,000.

MR. PRICHARD, of Lynn, Mass., is engaged on the construction of a building 75 feet by 35 feet, which is intended for the housing of a double set of improved water gas apparatus, the contract for which has been awarded to the United Gas Improvement Company.

THE Kansas City (Mo.) Gas Company's new holder (capacity 1,000,000 cubic feet), which is located in the district known as Turkey Creek Valley, has been completed. It is a credit to its builders and to its owners as well.

THE use of gas for cooking, heating and power purposes gains ground rapidly in Kansas City. Over 400 gas cookers are now in duty.

AT the stockholders' meeting of the Kansas City Company the following Directors were elected: M. J. Payne, W. W. Gibbs, L. F. Wilson, E. L. Martin and John A. McDonald.

A FRANCHISE for the construction and operation of a gas works at Riverside, Ia., has been granted by the City Council to Mr. John Hornick. This place is in Washington county, Ia., on the English river, and on the old Muscatine division of the Burlington, Cedar Rapids and Northern Railroad, at a point about 32 miles west of Muscatine. It is quite a manufacturing center, and will undoubtedly become an important factor in the commercial life of the State. Ten years ago it had a population of perhaps 500; now it can boast of 7,000.

ARRANGEMENTS are under way for the consolidation of the plants of the Batavia (N. Y.) Gas and Electric Light Company.

THE trust deeds conveying the plants of the Companies forming the combination of artificial lighting interests at Indianapolis, Ind., have been recorded. The trustees are the Central Trust Company, of New York, and Lafayette Perkins, of Indianapolis.

ONE day last week workmen in the employ of the Standard Gas Company of this city were engaged in laying on a gas supply to the private school for boys, under the tuition of Prof. Drisler, at No. 15 East 49th street. Through carelessness of the workmen an explosion resulted that caused damages to the amount of \$150. The Company might possibly find it advantageous to reorganize its street gangs.

AT a meeting of the Rockville (Conn.) Common Council, held the last week in May, a lively debate on the propriety of granting an opposition electric franchise took place. Mr. Charles Phelps appeared for the Rockville Gas Light Company—this Company has an electric light-

ing franchise, and supplies are lamps under it at the present time—and L. L. Tingier appeared for the projectors of the Merchants Electric Light Company. A remonstrance, signed by a large number of the local manufacturers, against granting the franchise, was presented by Mr. Phelps, after which Mr. Cary, special agent of the Thomson-Houston Company, was examined by the counsel of both Companies. Mr. Cary gave it as his opinion, from past experience, that a city of the size of Rockville was unable to support more than one artificial lighting company. Treasurer Stickney, of the Rockville Gas Company, said the Company had already expended \$25,000 on the plant now in operation, and that it was ready to put in incandescent lights as soon as a sufficient guarantee could be had from proposed users. Although Council refused to make a decision at the meeting in question, it is more than likely that the franchise will be refused.

The following is from the Kansas City (Mo.) *Journal*: "The matter of street lighting will soon receive serious consideration at the hands of the Council, and the facts and figures which will be presented to the two houses, will probably result in some very wholesome legislation. The Gas Committee of the upper house has been engaged for some time past in securing valuable statistics from cities throughout the country relative to the cost of street lighting, and the result shows that Kansas City pays more for her electric lights and gasoline lights, than any of the cities from which reports have been received. It cost this city \$77,542.58 to light the streets during the fiscal year ending April 21, 1890. This amount was paid to the different corporations in the following amounts:

Kansas City Gas Light and Coke Company.....	\$28,585.83
Missouri Valley Vapor Light Company.....	29,632.02
Kansas City Electric Light Company.....	17,432.98
American Electric Light Company.....	1,816.65
Westport.....	75.10
Total.....	\$77,542.58

The Committee has not yet secured all the information as to the cost of lighting the streets by gas, but the statistics at hand show that Kansas City is not paying a greater price for this kind of light than is paid by other cities throughout the country. This is explained, it is claimed, by the fact that other cities, like this city, are lighted by gas under old contracts, and, until new ones are entered into, there will be no material reduction. Other cities, like St. Louis, for instance, are abandoning gas for street lighting purposes and using electricity or gasoline, or both. The Kansas City Gas Light and Coke Company's franchise expires in a few years, and it will soon be necessary, therefore, for the city to enter into a new contract in case the Council deems it expedient to continue the use of gas for street lighting purposes. The Company will probably not seek a renewal of the old franchise as the capitalists who are interested in the present Company hold a franchise which was granted to another company some years ago and which they secured by purchase.

The statistics obtained by the Gas Committee show that the city is paying an exorbitant price for gasoline lamps, and that a new contract should be insisted upon at once. The present contract is between the city and the Missouri Valley Vapor Light Company, of which F. K. Hoover is President. It provides that the lamps shall be lighted according to moonlight schedule. That is, when the moon shines the lamps are put out; on nights when there is no moonlight, the lamps are kept burning. Four other cities from which the Committee obtained statistics, are lighted under similar contracts; a comparison of the prices follows:

Cities.	No. of Lamps.	Price per lamp per Month.
Kansas City.....	1,306	\$2.25
Lincoln, Neb.....	230	1.16 $\frac{2}{3}$
Wichita.....	480	1.70
Sioux City.....	300	1.40
Columbus, O.....	600	1.31 $\frac{1}{2}$

In the following cities the price is fixed on an all night schedule:

Cities.	No. of Lamps.	Price per lamp per Month.
Chicago.....	8,608	\$1.08
Omaha.....	900	1.41
Baltimore.....	829	90
Cleveland.....	6,028	1.24
Philadelphia.....	6,476	1.75
Lowell, Mass.....	416	1.80
Worcester.....	1,500	1.80
Cincinnati.....	1,709	1.63
New Haven.....	575	1.80
Providence.....	600	1.68

These figures will doubtless convince the members of the Council that it is time to enter into a new contract with the Company furnishing the gasoline lights. The Company is operating under an ordinance granted in 1883. This ordinance, according to the claim of President

Hoover, is a ten years' franchise. When Westport became a part of Kansas City an offer was made by a man named Powell to light that part of the new addition at a price greatly under that charged by the Hoover Company. The matter was referred to the gas committee of the lower house, and Mr. Hoover succeeded in killing off his competitor and inducing the committee to recommend that the new addition be lighted by his Company at the old figures. Judge L. C. Slavens, then City Counselor, held that the Missouri Valley Vapor Light Company did not hold an exclusive franchise or a franchise of any kind. That the contract even was no good, as the Council had no power to make any contract involving the appropriation of money, until the cash was in the treasury. For some reason, however, the committee ignored the opinion of the City Counselor, and Mr. Hoover carried his point. For several weeks, however, he was rather anxious as to the fate of what he calls his franchise, and almost daily haunted the city offices, and labored with the committee at its meetings. Mr. Hoover admitted to a *Journal* reporter at the time that he was making a good thing out of his contract, and did not want to see Powell get a foothold.

The following table shows that Kansas City is paying a pretty stiff price for its electric lights of 2,000 candle power:

Cities.	No. of Lights.	Cost per Light per Hour.
Kansas City.....	114	55 Cents.
St. Louis.....	1587	20 $\frac{1}{2}$ "
Philadelphia.....	1045	47 $\frac{1}{2}$ "
New Orleans.....	634	34 $\frac{1}{8}$ "
Omaha.....	109	47 $\frac{1}{2}$ "
Denver.....	216	53 "
Buffalo.....	1296	40 "
Montreal.....	850	40 "
Pittsburg.....	902	38 $\frac{3}{4}$ "
Providence.....	500	44 "
Cleveland.....	100	38 "
Baltimore.....	607	40 "
Sioux City.....	75	28 "
Toledo.....	530	27 $\frac{3}{4}$ "
Memphis.....	100	50 "
Duluth.....	186	35 "
Syracuse.....	304	40 "
Galesburg.....	118	33 "
Birmingham.....	109	33 $\frac{1}{2}$ "

There is set apart to the gas fund for the fiscal year, 1890, the sum of \$96,000. The gas committee estimates that it will take all this money to light the present lamps and pay for the electric lights now up. The councilmen from the new wards are flooding the council with ordinances for the location of gasoline lamps, but their streets will have to go unlighted unless the city forces the Vapor Light Company to reduce its prices. It is impossible to increase the fund, as every department is demanding more than has been given it. The committee is strongly of the opinion that it is time the city should cease paying a fancy price for street lighting.

THE auxiliary water gas plant for the Pittsfield Mass., Gas Company is to be completed by October 1st.

OBSERVER forwards the following, from New Bedford, Mass., under date of the 4th instant: "At the annual meeting of the New Bedford Gas Light Company, which will be held on July 1, the present President and Treasurer, Mr. Gilbert Allen, will decline a re-election, giving as reason therefor that the duties of the position take too much of his time. Mr. Allen is President of the Merchants Bank, Clerk of the Morse Twist Drill and Machine Company, President of the New Bedford Company, and is a Director in many other local business institutions. After the death of the first Treasurer of the Company (Mr. Jas. B. Congdon), the then President, Mr. William C. Taber, resigned, whereupon Mr. Allen was elected to serve in both capacities, which he has done ever since to the satisfaction of the Company and the public. It is whispered that the offices will be again divided, and that Mr. George R. Seaton will be named to the Presidency, and that Mr. R. Price will be chosen Treasurer."

THE Berlin Iron Bridge Company, of East Berlin, Conn., has received the contract for the iron buildings of the Huanchaca Company, of Bolivia, South America. The plans provide for a boiler house, 45 feet by 60 feet, an air-compressor house, 45 feet by 80 feet, and an engine house, 42 feet by 75 feet. These buildings will be made entirely of iron, put together at the Berlin Bridge Company's shops, taken apart again and shipped to Bolivia, where they will be erected by native workmen.

WE have it on good authority that the Warren (R. I.) Gas Light Company has again changed hands, the controlling interest most probably having been secured by Bristol capitalists.

THE Pawtucket (R. I.) Gas Company will add another gasholder to its possessions.

SITUATION WANTED

As Superintendent of a Gas Works,
By a man of 20 years' experience. Best of references. Ad-
dress JOHN COLLINS,
324 Clinton Street,
Schenectady, N. Y.
783-tf

Position Wanted

As Superintendent or Assistant of a Gas Works,
By a man who can give the best of references. Thoroughly
understands the manufacture and distribution of gas and the
construction of works. Address
779-5 "M.," care this Journal.

POSITION WANTED

As Superintendent of Gas Works.
Eleven years' experience in the manufacture of coal gas. Best
of references given.
W. L. CARVER, Supt.,
Carthage, Mo.
778-8

**WANTED,
A Six-Inch Exhauster.**

SECOND-HAND.
Must be in good condition. Roots' make preferred. Address
POUGHKEEPSIE GAS CO.,
Poughkeepsie, N. Y.
783-

FOR SALE.**One 5-ft. Station Meter,**

8-inch Connections.
In good order. Price, \$300, f.o.b. at Poughkeepsie, N. Y.
POUGHKEEPSIE GAS CO.,
Poughkeepsie, N. Y.
783-tf

Engines and Boilers For Sale

Five 80-H.P. Ft. W. Bass Automatic Cut-Off
Engines, 12 by 16 in.
Three 40-H.P. Arrington & Sims Automatic
Cut-Off Engines, 9 by 12 in.
One 50-H.P. New York Safety Automatic Cut-
Off Engine, 10 by 12 in.
Four Tubular Boilers, Steel, 16 ft. by 60 in., forty-four
4 in. flues. Full front.
Two Tubular Boilers, Steel, 16 ft. by 60 in., eighty
3-in. flues. Full front.
One No. 5 Dean Pump.
Three Sets J. H. Turner Patent Heaters.

The above are in good condition and in operation. Write for
particulars.

JENNEY ELECTRIC LIGHT AND POWER CO.,
Peoria, Ill.
783-tf

FOR SALE,**The Ironwork for Ten Benches
of Fives (5's).**

Cast iron Hydraulic Main, 16 by 18 in. Stand Pipes, 5 in. at bot-
tom, 4 in. at top. Bridge and Dip Pipes, 4 in. Address
DAYTON GAS LIGHT AND COKE CO.,
120 East Third Street, Dayton, Ohio.
783-tf

**Who Makes
TAR SEPARATORS?**

Prices and particulars, address

"X. Y." care this Journal.

FOR SALE,

The Ironwork for Twelve Benches of 6's, viz.:
Cast Iron Hydraulic Main.
7-inch Dip-Pipes, Stand-Pipes, and Bridge-
Pipes, complete.
Floyd Mouthpieces and Self-Sealing Lids, 15x26 in.
Lids and Mouthpieces only in use over a year. Will be sold
cheap. ISAAC C. BAXTER,
772-tf Detroit (Mich.) Gas Lt. Co.

MOSES G. WILDER, MECH. ENGR.

816-18-20-22 Cherry St., Phila., Pa.

Volumetric Lamp Governors

FOR GAS LAMPS & HIGH-POWER BURNERS.

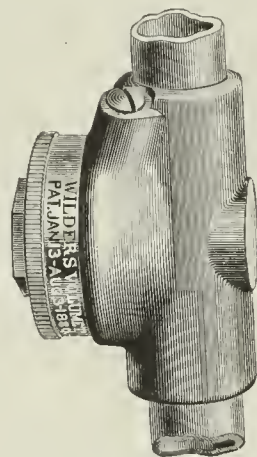
**GOVERNOR BURNERS**

for
STREET LAMPS AND
GENERAL USE,
and
GOVERNORS FOR ARGAND
AND OTHER COMMON GAS
BURNERS IN ALL SIZES.

**HORIZONTAL
Governors**

Specially adapted for
GAS STOVES, FURNACES,
Etc., Etc.

It is well known that a large majority of all High Power Gas
Lamps in the United States have my Governors attached, and
they are always used by the leading makers of these lamps. To
remove any excuse for the use by anyone of inferior and in-
fringing Governors, a reduction in price has been made, and all
exclusive contracts are cancelled.

Correspondence Solicited with all who require a Reliable
Governor.

PATENTS.

FRANKLIN H. HOUGH

Solicitor of American & Foreign Patents.

925 F. ST., WASHINGTON, D. C.

(NEAR U. S. PATENT OFFICE.)

Personal attention given to the preparation and prosecution
of applications for Letters Patent. All business before the U. S.
Patent Office attended to for moderate fees. **No Agency in
the United States possesses superior facilities
for obtaining Patents**, or for ascertaining the patent-
ability of inventions. Copies of patents furnished for 25 cents
each. Correspondence solicited.

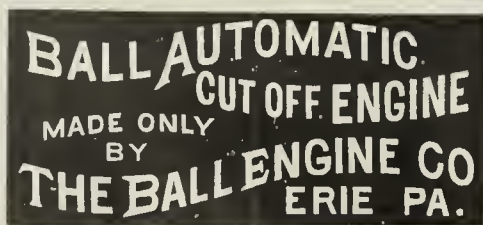
**GASHOLDER PAINT.**

Use Only

THE GOVERNMENT WATERPROOF PAINT.

Proof against Ammonia, and Absolutely Waterproof. Send for Prices and Particulars.
THE GOVERNMENT WATERPROOF PAINT CO., 122 Milk Street, Boston, Mass.

Simpkin & Hillyer

RICHMOND, VA.

MANUFACTURERS OF

Gas Works Apparatus

BENCH CASTINGS, CONDENSERS,

Scrubbers, Purifiers, Dry Center Seals,

FOUR-WAY VALVES, GAS VALVES,

SULPHATE OF AMMONIA APPARATUS,
TANKS, ENGINES, BOILERS,
PUMPS, ETC., ETC.

Plans, Specifications and Estimates furnished for new works,
or alteration of old works. Correspondence solicited. Works,
Newport News, Va.

FRIEDRICH LUX,

Ludwigshafen am Rhein and London.

Lux Mass

GAS GOVERNORS,

Gas Balance.

Fuel and Its Applications.

By E. J. MILLS, D.Sc. F.R.S., and F. J. ROWAN, C.E., assisted
by others, including Mr. F. P. Dewey, of the

Smithsonian Inst., Wash., D. C.

7 PLATES, AND 607 OTHER ILLUSTRATIONS. ROYAL
OCTAVO, PAGES xx, 802. HANDSOME CLOTH, \$7.50.

A. M. CALLENDER & CO., 42 Pine St., N. Y.

Bartlett Street Lamp Mfg. Co.

MANUFACTURERS OF

Globe Lamps,

FOR

Streets, Parks, Public
Buildings, Railroad
Stations, etc.

LAMP POSTS

A Specialty.

Office and Salesroom,

40 & 42 COLLEGE PLACE, - - N. Y. CITY.

Gas Companies and others intending to erect Lamps
and Posts will do well to communicate with us.



THE BERLIN IRON BRIDGE CO.

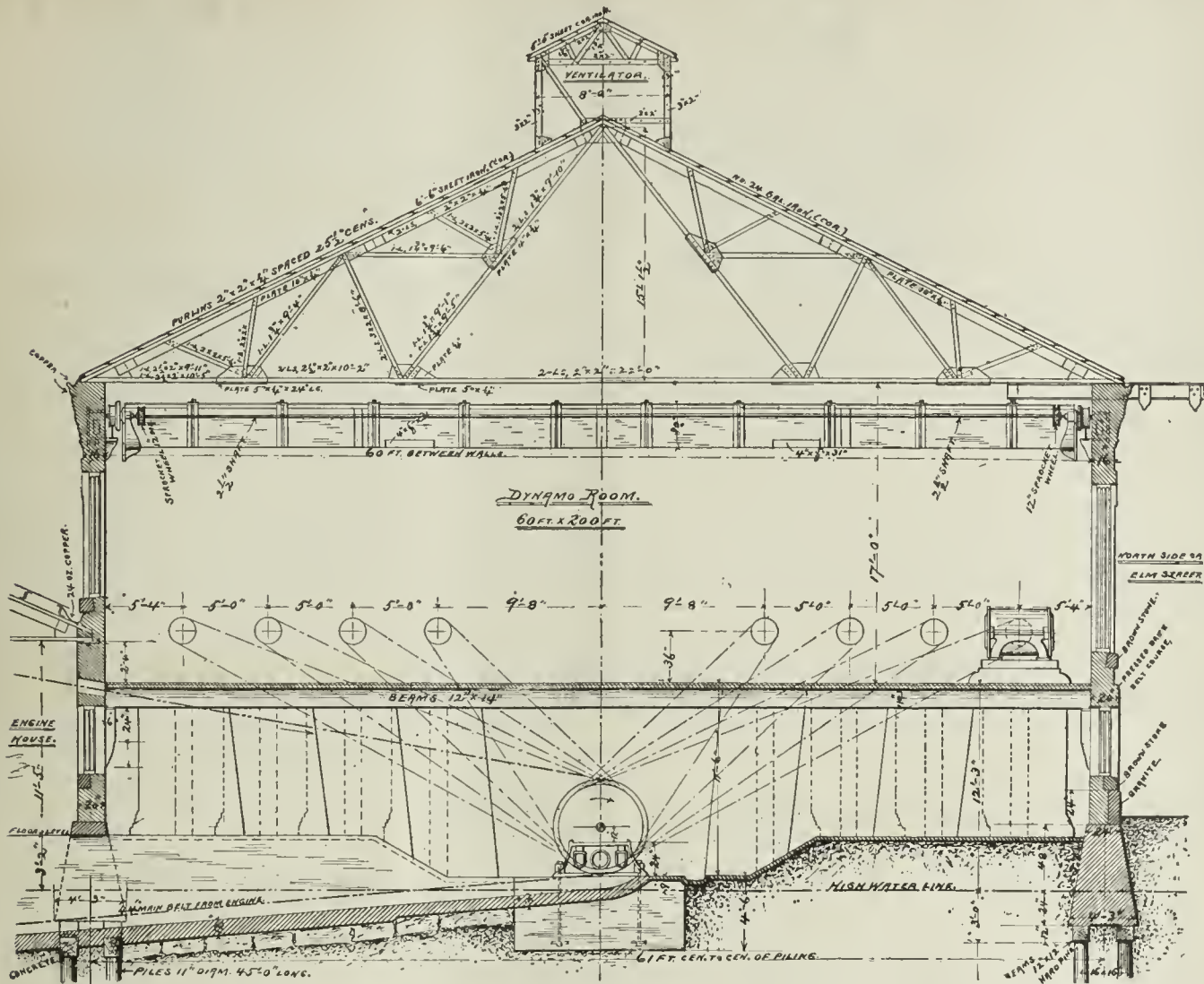

Cross Section of
 THE DYNAMO HOUSE
 of the
 NARRAGANSETT ELECTRIC
 LIGHTING COMPANY,
 at
 PROVIDENCE, R. I.,
 Showing the
 IRON TRUSSES, IRON TRAV-
 ELING CRANE,
 and the
 GENERAL ARRANGEMENT
 OF THE BELTS.

The building is 60 feet wide by 200 feet long, and running length-ways the entire length of the building is a traveling crane for the purpose of raising and lowering the machinery in position. This building is pronounced the most complete Electric Light Station anywhere in the country.

WRITE TO US FOR PLANS AND ESTIMATES FOR THIS CLASS OF WORK.

Office and Works,
 East Berlin, Conn.

FORT WAYNE ELECTRIC CO.

FORT WAYNE, IND.

MANUFACTURERS OF THE

Slattery Induction System

—OF—

LONG DISTANCE INCANDESCENT LIGHTING.

The Most Carefully Worked Out and Complete Alternating Current System of Electric Lighting in Existence.

—AND THE—

WOOD

Automatically Regulating
ARC DYNAMOS and LAMPS.

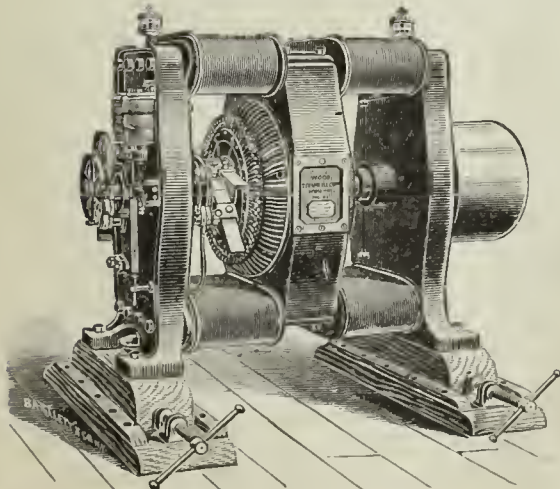

Wood Dynamo.

Main Office, - - - Fort Wayne, Indiana.

Factories: Fort Wayne, Ind.; Brooklyn, N. Y.

BRANCH OFFICES.

NEW YORK, - - - 115 Broadway.
 PHILADELPHIA, - - - 907 Filbert Street.
 CHICAGO, - - - 185 Dearborn Street.
 SAN FRANCISCO, - - - 35 New Montgomery Street.

DETROIT, MICH., - - - 57 Gratiot Avenue.
 TORONTO, CANADA, - - - 138 King Street, West.
 MEXICO, F. Adams' Successors, - - - City of Mexico.
 CUBA, Maicas & Co., - - - Havana.

The Gordon Portico Lamp.

A successful Competitor of the Arc Electric Light for lighting Store Fronts, Show Windows, Depots, Railway Sheds, etc., etc.

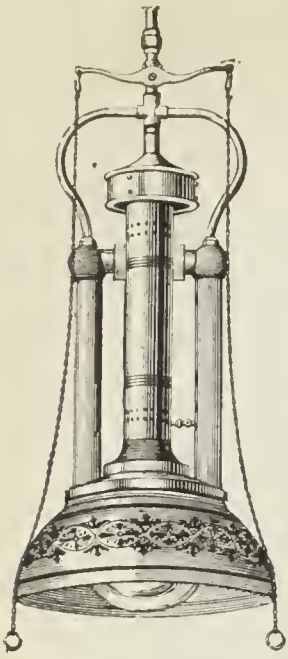

Gordon Portico Lamp.

The Gordon Street Lamp.

A Successful Competitor of the Arc Electric Light for lighting Streets, etc., etc.

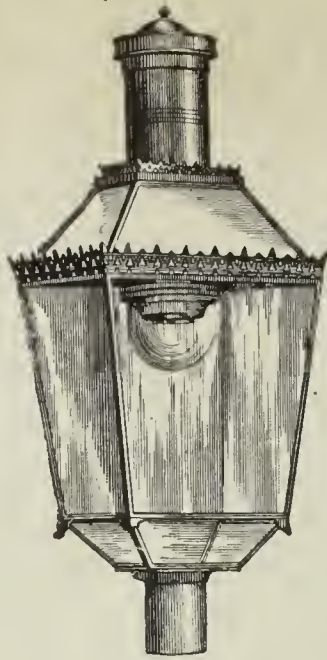

Gordon Street Lamp.

The Lungren Lamp.

A Successful Competitor of the Incandescent Electric Light for Interiors, etc. Is especially applicable for the lighting of Offices, Stores, Factories, Mills, Show Windows, Libraries, and all situations where an increased illumination is desired.

More than 25,000 Lungren Lamps are now in use. Testimonials, references, or any desired information will be cheerfully given.



Lungren Lamp.

THE SIEMENS-LUNGREN CO., N.E. Cor. 21st St. & Washington Av., PHILADELPHIA.

WELSBACH SYSTEM OF Incandescent Gas Lighting.

OFFICE, DREXEL BUILDING, PHILA., PA.

At the Fall Session of the Board of Supervisors of Winnebago County, held at the County Court House, Oshkosh, Wis., Nov. 26, 1889, the report submitted by Mr. C. W. Cook, Chairman of the Committee on Public Buildings, recommending the use of the Welsbach Incandescent Gas Burner in the Buildings under their charge, was unanimously adopted, because of the extreme economy in the consumption of Gas and the superior character of the light obtained.

CHARLES E. DICKEY.

JAMES B. SMALLWOOD.

CHARLES H. DICKEY.

THE MARYLAND METER AND MANUFACTURING CO.

Established 1866.

BALTIMORE, North & Saratoga Sts.

CHICAGO, 197 Michigan Street.

NEW YORK, 766 Broadway.

BOSTON, 4 Central Street.

ST. LOUIS, 1115 Olive Street.

SAN FRANCISCO, 330 Pine Street.

CONSUMERS' & STATION METERS, PRESSURE GAUGES, Etc., Etc.

"Success" and "Perfect" Gas Stoves.

EDGEWATER LIME WORKS

Chas. F. McKenna, Proprietor.

SHELL LIME.

Lime by the Cargo for Gas Purification.

EDGEWATER, BERGEN CO., N. J.

Write for Testimonials and Prices.

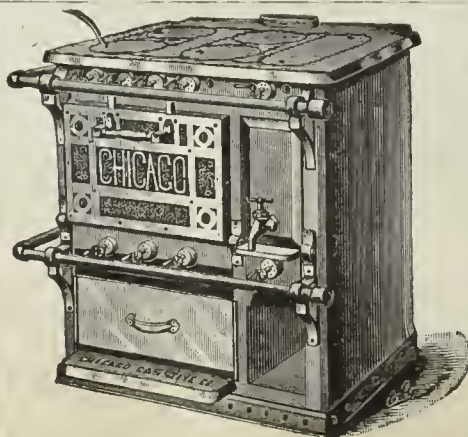

CHICAGO GAS STOVE CO.

MANUFACTURERS OF ALL KINDS OF

Gas Cooking and Heating
APPLIANCES.

117-119 Lake St., CHICAGO.

Send for Catalogue.

JEWEL GAS STOVES

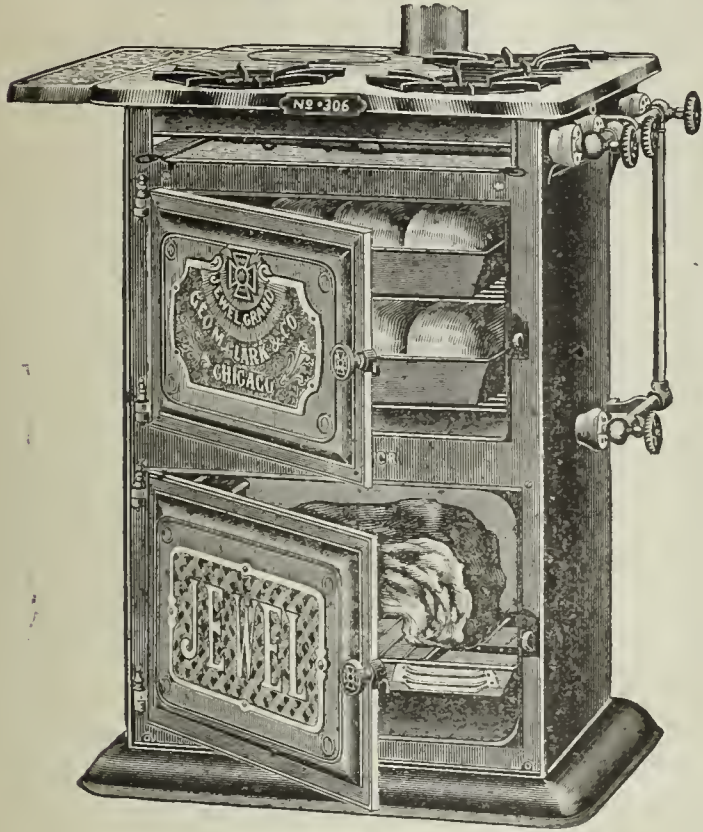

Are Best,

BECAUSE THEY ARE

HIGH GRADE,

Interchangeable,

RIGHT!

WE USE NO GAS COCKS.

All Flames are Regulated by Direct Needle Valves.

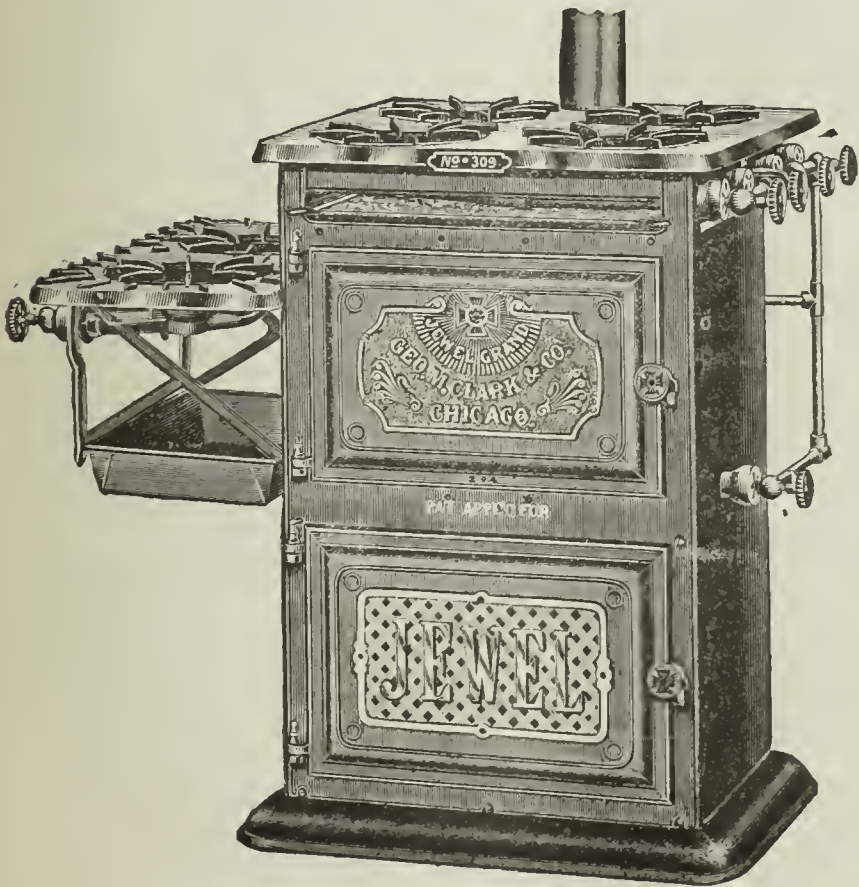

JEWEL CIRCULATING WATER HEATER.

No. 510, - - - - \$15.00.

Write

for

Jewel

1890

Catalog.

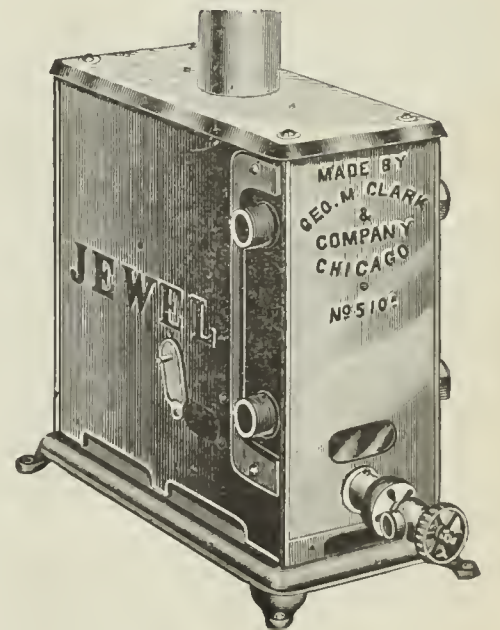

GEORGE M. CLARK & COMPANY,

MANUFACTURERS,

157 & 159 Superior Street, - - - Chicago, Ill

NATIONAL GAS LIGHT AND FUEL CO.,

218 La Salle Street, Chicago.

C. D. HAUK, Prest. & Gen'l Manager. A. W. GREEN, Vice-Prest. N. A. McCLARY, Sec. & Treas. E. E. MORRELL, Engr.

GAS WORKS

Built, Remodeled, Leased, and Purchased.

71 Springer Cupolas have been installed in the U. S. during the past four years.

The total capacity of Springer Apparatus now in use is over 25,000,000 ft. daily.

THE SPRINCER CUPOLA SYSTEM

Has Proven Itself the most Economical and Satisfactory Method of Gas Manufacture ever brought to the attention of the Gas Fraternity.

GUARANTEED ESTIMATES of Cost of Gas Furnished on Application.

GASHOLDER TANK CONSTRUCTION, ETC.

Gas Companies and others about to erect Gasholders will find it profitable to consult W. C. Whyte, who for over 30 years has made a specialty of

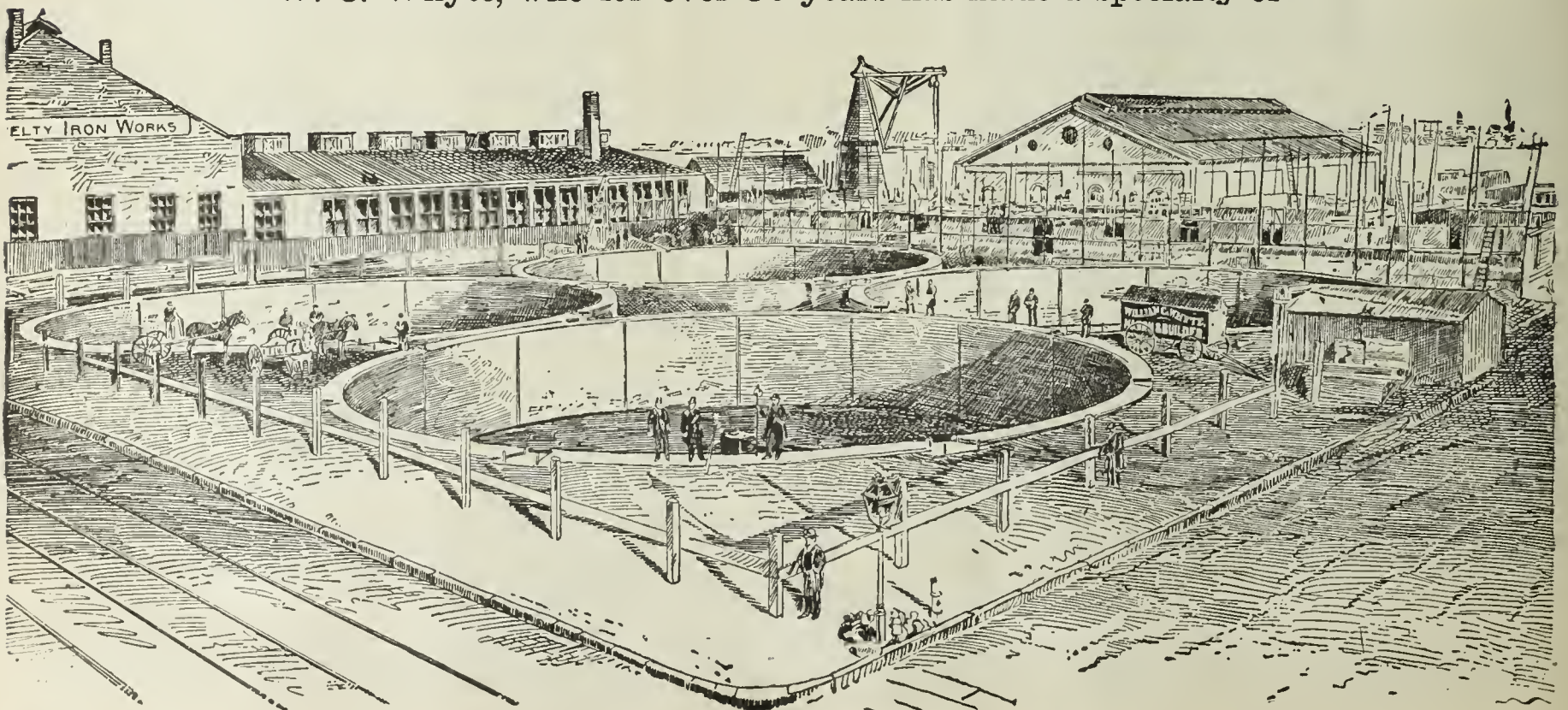

Tank Excavation and Mason Work.

Fifty Tanks now in operation show the sort of work done. Address

W. C. WHYTE, - No. 15 Cortlandt Street, N. Y. City.

GAS STOVES.

GAS METERS.

GAS STOVES.

THE AMERICAN METER CO.

Established 1834.

Incorporated 1863.

MANUFACTURERS OF

Gas Meters,

STATION METERS,

METER PROVERS, PHOTOMETERS,

Pressure Gauges of all Kinds,

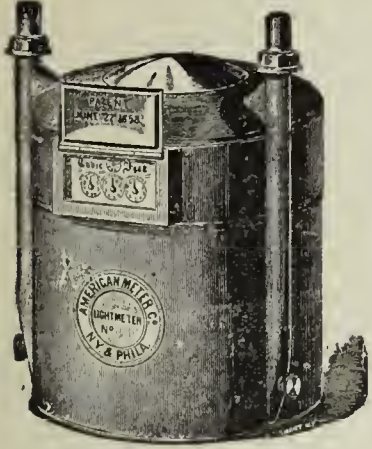

Standard 3 Diaphragm Dry Meter.



Standard 2 Diaphragm Dry Meter.

AND

Apparatus for Testing the Quantity and Quality of Gases.

GAS STOVES FOR HEATING AND COOKING.

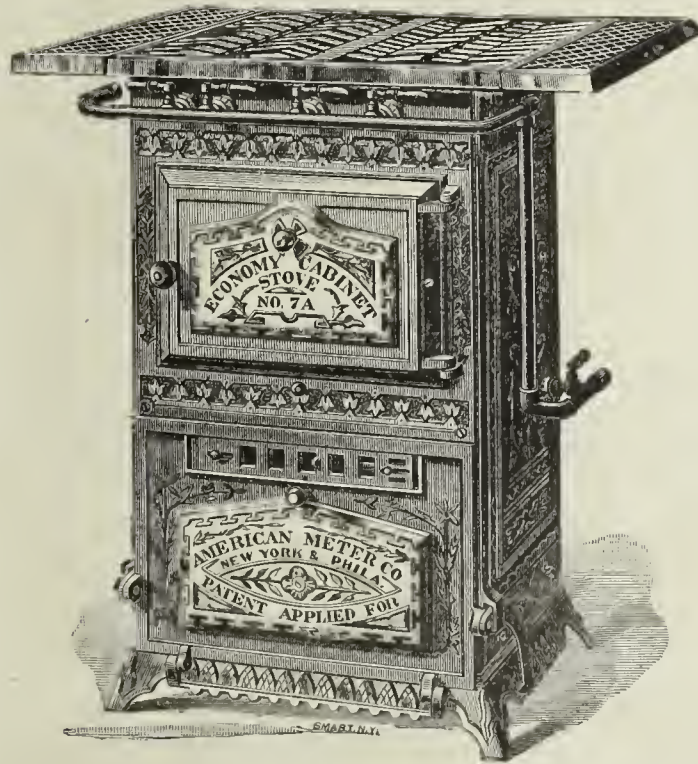

Circulars and Price Lists on Application.

MANUFACTORIES,

508 to 514 West Twenty-second St., N. Y.

Arch and Twenty-second St., Phila.

Nos. 244 & 246 North Wells Street, Chicago, Ill.

AGENCIES,

No. 177 Elm Street, Cincinnati, Ohio.

No. 222 Sutter Street, San Francisco, Cal.

No. 810 North Second Street, St. Louis, Mo.

GAS STOVE SHOW ROOMS, No. 242 Sixth Avenue, New York City.

THE WALKER TAR AND CARBONIC ACID EXTRACTOR.

A very general demand exists, in both large and small Gas Works, for an apparatus that will be absolutely efficient in the removal of the tar which passes the hydraulic main and condenser. Many attempts have been made to accomplish this, but, I believe, without success, until the introduction, five years ago, in England, of the C. & W. Walker Patent Tar and Carbonic Acid Extractor. During these years this apparatus has been adopted by many of the most prominent Engineers, not only in England, but also on the Continent of Europe and in other parts of the world. It is only necessary to give here a partial list in order to convince any intelligent American Gas Engineer that this machine must have succeeded fully in accomplishing the desired results.

The following Engineers have personally given permission to refer to them:

G. C. Trewby, Esq., Engineer-in-Chief of the Gas Light and Coke Co., London. The manufacturing plant at Beckton is built in complete sections of 3,000,000 cubic feet capacity each. A Walker Tar Extractor has been fitted to each one of these sections. This was done after a long and thorough trial on one of its sections. The Tar Extractor has been supplied to other works of the Gas Light and Coke Co., including those of which John Methven, Engineer of the Gas Light and Coke Co. at the Nine Elms Station, is in charge. Also to G. E. Stevenson, Peterborough Gas Works; B. Green, Mitcham and Wimbledon Gas Works; W. H. Smith, Bedford Gas Works; F. Linging, Norwich Gas Works; J. T. Browning, Colchester Gas Works; S. B. Darwin, Portsmouth Gas Works; J. McCrae, Dundee Gas Works; W. J. Wells, Stamford Gas Works; J. M. Darwin, Longton Gas Works; J. Paterson, Warrington Gas Works; and J. Coulter, of the Dundalk Gas Works. All of the foregoing gas works are located in Great Britain.

Mr. Charles A. Gerdenier, Superintendent of the Bridgeport (Conn.) Gas Light Company, writes as follows, under date of Dec. 3, 1887:

"The C. & W. Walker Tar and Carbonic Acid Extractor has been in operation at these works for the past six weeks, and is an unqualified success. It removes every particle of Tar from the gas in once passing through the apparatus, and a large percentage of the Carbonic Acid. I also feel quite sure that it prevents the formation and deposit of Naphthaline, because since I started the Washer I have had no stoppages from this cause. These works have been seriously troubled with Tar for many years, and I have used several kinds of apparatus and every expedient which has come to my attention for dealing with the difficulty, but without success. The Walker apparatus occupies comparatively small space, is less expensive than other systems, and requires but little attention. I carry 2½-inch seal, and have an automatic tar delivery valve. This Tar Extractor is indispensable to gas makers."

I have taken the Agency for the United States for this apparatus, and am now prepared to make contracts to erect it on the premises of any Gas Company. It would be manufactured in the following sizes:

No. 1,	50,000 to	100,000	cu. ft. per 24 hrs.,	3	ft. square,	5	ft. deep.
No. 2,	"	125,000	" " "	4	"	"	"
No. 3,	"	250,000	" " "	5	"	"	"
No. 4,	"	500,000	" " "	6	"	"	"
No. 5,	"	750,000	" " "	7	"	"	"
No. 6,	"	1,000,000	" " "	8	"	"	"
No. 7,	"	1,250,000	" " "	9	"	"	"
No. 8,	"	1,500,000	" " "	10	"	"	"
No. 9,	"	2,000,000	" " "	12	"	"	"
No. 10,	"	3,000,000	" " "	15	"	"	"

This Tar Extractor will perform its work with about one-fourth the usual back-pressure heretofore required. It is simple in construction, and can be supplied at a very reasonable price—less than any other ever before introduced. Satisfactory results will be guaranteed in every instance.

GEO. SHEPARD PAGE,

SOLE AGENT FOR THE UNITED STATES,

No. 69 Wall Street, - - - New York.

THE UNITED GAS IMPROVEMENT CO.,

DREXEL BUILDING, PHILA., PA.

Owners of the Lowe, Granger-Collins, McKay-Critchlow (for carbureting Natural Gas), and Other Gas Patents.

BUILDERS, LESSORS *and* PURCHASERS OF GAS WORKS.

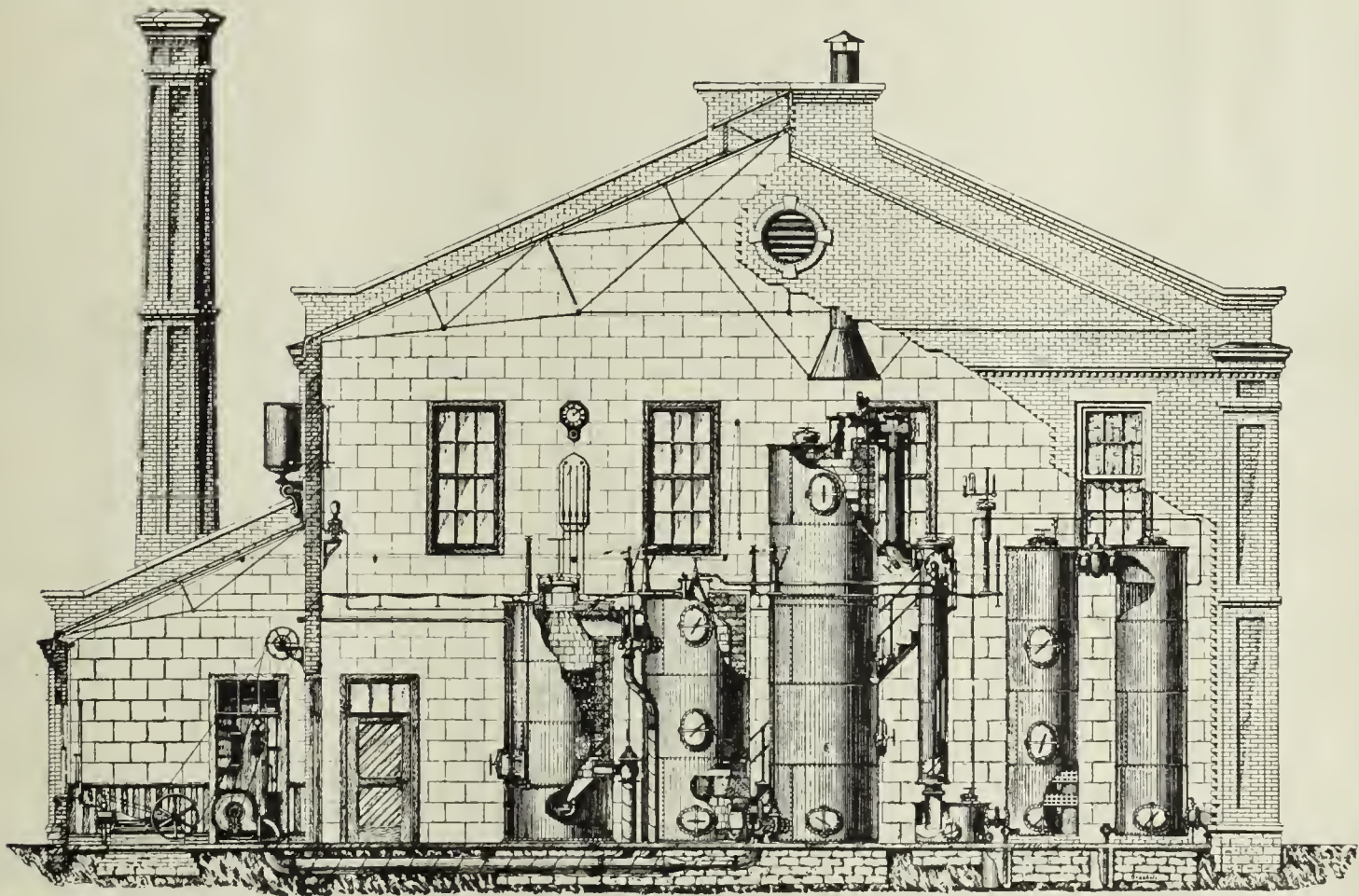

Standard "Double Superheater" Lowe Apparatus, Especially Designed for the Use of Lima Crude Oil.

Erectors of

WATER GAS PLANTS,

(Either Independent or Auxiliary to Coal Gas Works),

USING LIMA OR OTHER LOW GRADE OILS AND ANTHRACITE COAL OR GAS HOUSE OR OVEN COKE.

PAMPHLETS, PLANS, AND ESTIMATES FURNISHED UPON APPLICATION.

ROOTS' GAS AND BYE-PASS VALVES.

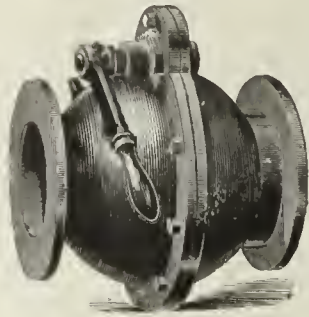

GAS VALVE

Quick Acting,
Simple,
Efficient, Durable.

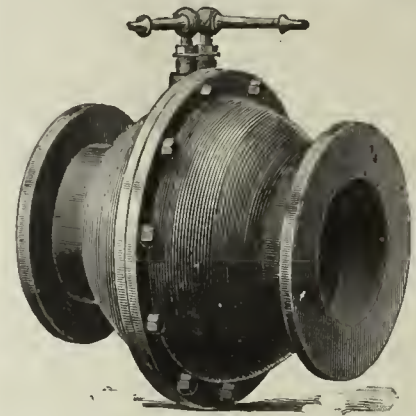

BYE-PASS VALVE.

Automatic Action
Reliable
Simple Durable.

Thousands now in use and giving perfect satisfaction. Write for Catalogue and Prices.

ROOTS' NEW GAS EXHAUSTER.

Unsurpassed
for Neatness
of Design,
Durability,
Simplicity,
Efficiency,
and Economy
of Power.

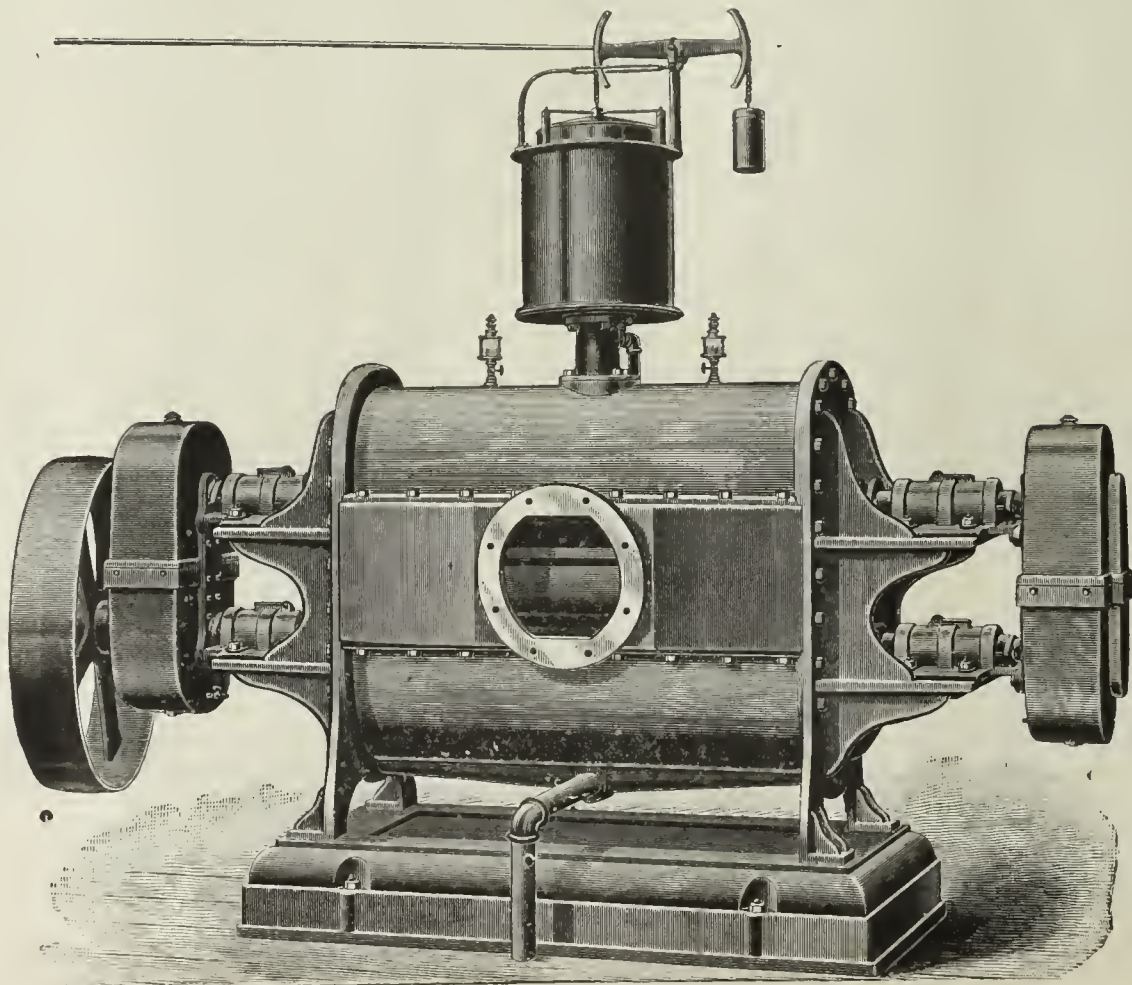

All Parts
Requiring
Attention
are External
and Easily
Accessible
at all Times.

Send for Descriptive Catalogue and Price List.

THE P. H. & F. M. ROOTS CO., Patentees and Manufacturers, **CONNERSVILLE, IND.**

S. S. TOWNSEND, Gen. Agt., 22 Cortlandt St., N. Y. COOKE & CO., Selling Agts., 22 Cortlandt St., N. Y.

CONNELLY & CO.,

SOLE MANUFACTURERS OF THEIR PATENTED SPECIALTIES.

"IRON SPONGE."

Saves money, saves labor, and is the most efficient purifying agent ever offered as a substitute for lime. Now used in every State in the Union, and purifying daily over thirty-five million cubic feet. Should be used in every gas works. Its own saving will pay for it many times over.

AUTOMATIC GOVERNOR.

Has been on the market but three years, and in that time has been introduced more generally than any invention ever designed for use in gas works. Over two hundred of them now in use. Sensitive; reliable; perfectly automatic; reduces leakage; satisfies consumers, and gives great relief to the Manager. No gas works is complete without one of these machines.

STEAM JET EXHAUSTER.

Designed particularly for small works. Combines Exhaust Tube, Steam Governor Gas Compensator, and Bye-Pass Valves in the most compact form possible; occupies but little space; uses very little steam; operated by ordinary workmen; saves formation of carbon in retorts; increases yield 10 to 15 per cent. Specially adapted for mixing air with oil gas. No works too small to use them profitably.

Prices given on all our specialties delivered at any point in the United States. Correspondence solicited.

CONNELLY & CO., No. 111 Broadway, New York City.

WILBRAHAM GAS EXHAUSTER & ENGINE COMBINED.

WILBRAHAM BROS.,
PHILADELPHIA, PA.

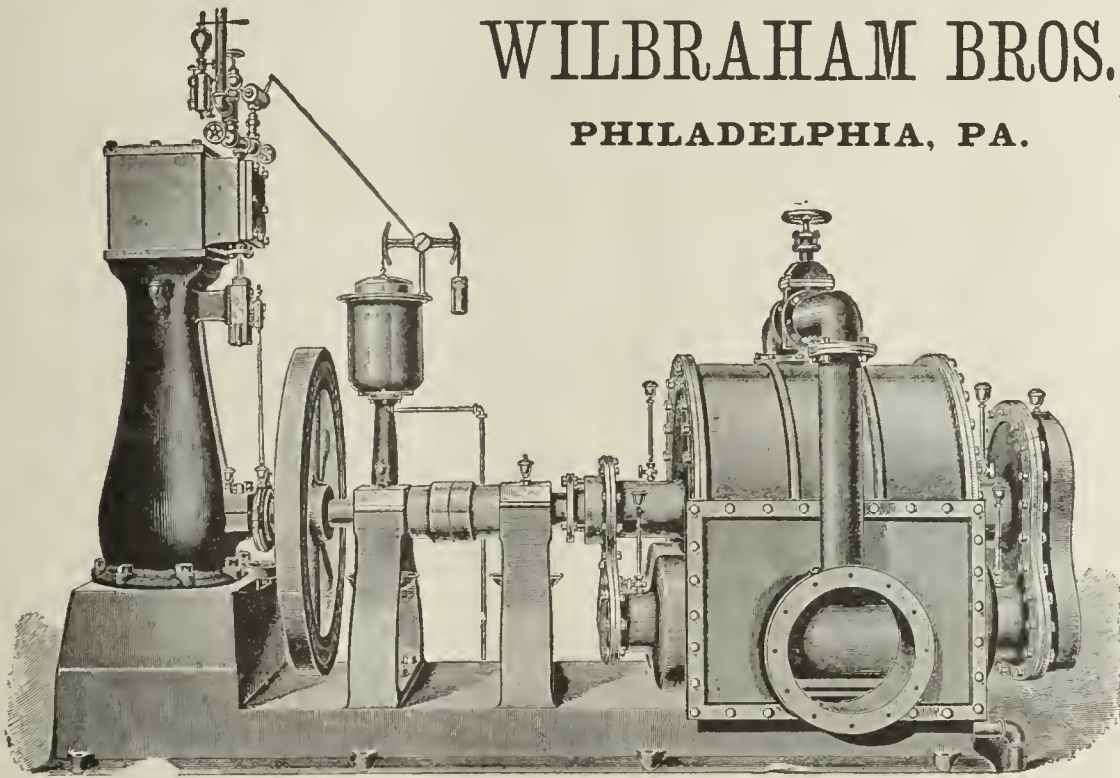

JARVIS ENGINEERING CO.,

61 Oliver St., Boston, Mass.

CONTRACTORS FOR ERECTING

COMPLETE STEAM OUTFITS FOR ELECTRIC LIGHTING STATIONS.

Steel Boilers set with Jarvis Pat. Boiler Setting

To burn COKE SCREENINGS for Fuel.

ARMINGTON & SIMS CO. ENGINES,

Belting direct to Dynamos, without using Shafting.

SEND FOR CIRCULARS.

REFERENCES.—Charlestown Gas & Electric Light Co., Charlestown, Mass.; Schenectady Gas & Electric Light Co., Schenectady N. Y.; Brookline Gas Co., Brookline, Mass.

Practical Electric Lighting

By A. BROMLEY HOLMES, A.M.I.C.E.

With 87 Illustrations. Third Edition. Price, \$1.00.

Electric Light Primer.

By CHARLES L. LEVEY.

A simple and comprehensive Digest of all the most important facts connected with the running of the Dynamo and Electric Lights, with Precautions for Safety, etc.

Price, 50 cents.

A. M. CALLENDER & CO., 42 Pine St., N. Y.

Gasholder Tanks & Gas Works Masonry Complete.

PLANS PREPARED AND ESTIMATES FURNISHED AT SHORT NOTICE.

J. P. WHITTIER, - - 499 Wythe Av., Brooklyn, N. Y.

1890 DIRECTORY 1890

OF THE GAS LIGHT COMPANIES of the UNITED STATES & CANADA.

Price, \$5.00.

A. M. CALLENDER & CO., No. 42 Pine Street, N. Y. City.



CHAPMAN VALVE MANUFACTURING CO.,

MANUFACTURERS OF

Valves and Gates for Gas, Ammonia, Water, Etc.

Also, Gate Fire Hydrants With and Without Independent Nozzle Valve. All Work Guaranteed.

WORKS & GEN'L OFFICE:
Indian Orchard, Mass.

TREASURER'S OFFICE:
72 Kilby & 112 Milk Sts, Boston, Mass.

LUDLOW VALVE MFG. CO.



OFFICE AND WORKS,

938 to 954 River Street and 67 to 83 Vail Av.,
TROY, N. Y.

Hydraulic Main Dip Regulators, also
Check Valves, Foot Valves, Yard-
wash and Fire Hydrants.
Send for Circulars.



Valves.—Double and Single Gate, 1/2 in. to
48 in., outside and inside Screws. Indica-
tor, etc., for Gas, Water, Steam, and Oil.
Send for Circulars.

Parson's Steam Blower,

FOR IMPROVING BAD DRAUGHT IN BOILERS, AND FOR BURNING BREEZE OR OTHER WASTE MATERIAL.

PARSON'S TAR BURNER,

FOR UTILIZING COAL TAR AS FUEL.

PARSON'S AIR JET TUBE CLEANER,

FOR CLEANING BOILER TUBES.

These devices are all first-class. They will be sent to any responsible party for trial. No sale unless satisfactory. Manufactured by the WATERTOWN STEAM BLOWER COMPANY.

H. E. PARSON. Supt., 33 & 35 Liberty St., N.Y

MILLS' REVERSIBLE LIME TRAY,

AND

WOODWORK

Of Every Description

NEEDED BY GAS WORKS.

SEND FOR CIRCULAR AND PRICE LIST TO

BARTLETT, HAYWARD & CO.,

Pratt and Scott Streets, Baltimore, Md.

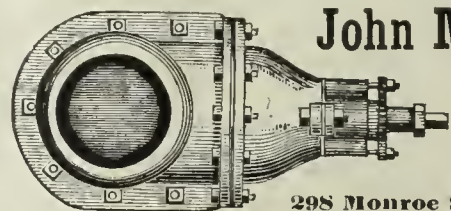
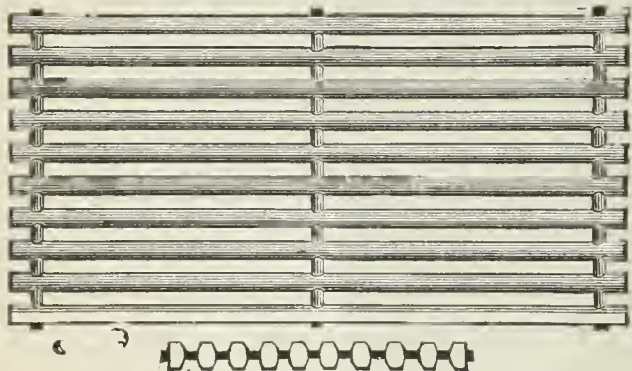

John McLean

Man'facturer

GAS VALVES.

298 Monroe Street, N. Y.

VAN DUZEN GAS & GASOLINE ENGINE

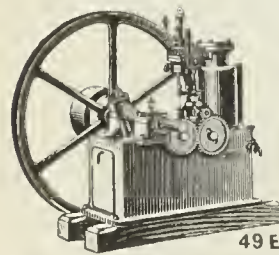

OPERATED with COAL and OTHER MANUFACTURED GASES AND GASOLINE.

RELIABLE AND ECONOMICAL.

Fully Warranted

VAN DUZEN

Gas & Gasoline Engine Co.

49 E. 2d St., Cincinnati, O.

A. MacKinnon Machine Co., Agts., 22 Warren St., N.Y.

The Management of Small Gas Works.

BY C. J. R. HUMPHREYS.

Price, \$1.

Orders to be sent to **A. M. CALLENDER & CO.,**

42 PINE STREET, NEW YORK.

CHURCH'S TRAYS A SPECIALTY.

REVERSIBLE-STRONGEST-MOST DURABLE-MOST EASILY REPAIRED.

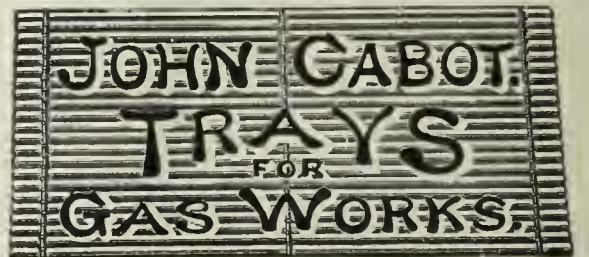

306-310 ELEVENTH AVENUE, NEW YORK.

WE ALSO MAKE THE CHEAPEST AND STRONGEST REVERSIBLE BOLTED TRAYS IN THE MARKET.

THE CLERK GAS ENGINE CO.,

Main Office, 1012, 1014, 1016, 1018 Filbert St., Philadelphia, Pa.

WM. W. GOODWIN, Prest.

E. STEIN, Sec.

S. LEWIS JONES, Asst. Sec.

A. J. DOTY, Supt.

The utility and convenience of the Gas Engine being no longer an open question, it only remains now for intending purchasers to select the BEST. We claim for the CLERK GAS ENGINE that it is equal to any other manufactured as regards steadiness in running, simplicity, and ease of keeping in repair, and that it gives the greatest amount of power for the least money (both in first cost and expense of running) of any engine made. In support of this claim we refer to the test of the Gas Engines made under the direction of the American Institute of New York, in December, 1885, and heretofore published in these columns. These engines are especially adapted for continuous running under heavy loads, and we can refer to Engines which have run 22 hours a day for months at a time

Made in Sizes of 5, 10, 15, 20, and 25 Horse Power. All Engines Guaranteed for One Year.

ENGINEERS.

P. D. WANNER, Chairman. A. H. MELLERT, Mangr. of Wks.
R. B. KINSEY, Secretary. F. A. KNOPP, Treasurer.

MELLERT FOUNDRY & MACHINE CO. Ltd.
and **READING FOUNDRY CO., Ltd.**
Reading, Pa.



Specials—Flange Pipe, Valves and Hydrants
Lamp Posts, Retorts, etc.
General Foundry and Machine Work.
JOHN FOX, Selling Agent. 160 Broadway, N. Y.

THE OHIO PIPE COMPANY,
MANUFACTURERS OF

Cast Iron Gas & Water Pipe,
BRANCH AND SPECIAL CASTINGS.

Gas-House Bench Castings, Hydraulics, Lamp Posts, Flange Pipe
and Specials, Architectural Castings, Building Columns,
Joists, Cellar Grates, Sash Weights, etc.

GENERAL FOUNDERS AND MACHINISTS.
Columbus, Ohio.

M. J. DRUMMOND,



SPECIAL CASTINGS AND LAMP POSTS.
Office, Corbin Building, 192 Broadway, N. Y.

EMAUS PIPE FOUNDRY.
DONALDSON IRON COMPANY. EMAUS, PA.



MANUFACTURERS OF
CAST IRON PIPE AND SPECIAL CASTINGS
FOR WATER AND GAS.

JOS. R. THOMAS,
No. 42 Pine Street, N. Y. City.
CONSULTING AND CONSTRUCTING
Gas Engineer and Contractor.

PLANS, SPECIFICATIONS, AND ESTIMATES
FURNISHED.

Contracts taken for all Appliances
required at a Gas Works,
Either for New Works or Extensions to Old Plants.

WM. MOONEY
(Successor to WM. FARMER)

No. 94 Liberty St., N. Y. City.
GAS ENGINEER AND CONTRACTOR FOR THE ERECTION
OF GAS WORKS, OR APPARATUS OF ANY
CAPACITY.
Plans and Specifications Furnished.

WM. GARDNER,
Gas Engineer,
Lewis Block, Room 20, Pittsburgh, Pa.

Those who intend to make alterations in existing gas plants, or
who contemplate the erection of new works, will find it to their
interest to open correspondence with the above. Plans made
and estimates furnished.

GAS AND WATER PIPES.

SAM'L R. SHIPLEY, Pres.
HENRY B. CHEW, Tre.

GLOUCESTER IRON WORKS,
GLOUCESTER CITY, N. J.



JAS. P. MICHELLON, Sec.
WM. SEXTON, Supt.

Cast Iron Gas & Water Pipes, Stop Valves, Fire Hydrants, Gasholders. &c.
Office, Rooms 61 and 63 Bullitt Building, 131 S. 4th St., Phila., Pa.

WARREN FOUNDRY AND MACHINE CO.,

Established 1856. Works at Phillipsburgh, N. J.

New York Office, 160 Broadway.

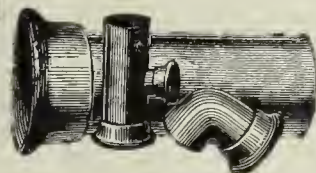

CAST IRON WATER AND GAS PIPE,

FROM TWO TO FORTY-EIGHT INCHES DIAMETER. ALSO, ALL SIZES OF

Flange Pipe for Sugar House and Mine Work. Branches, Bends, Retorts, etc., etc.

DENNIS LONG & COMPANY,

LOUISVILLE, KY.,



Manufacture Exclusively

CAST IRON GAS & WATER PIPE & SPECIAL CASTINGS
OF ALL SIZES.

King's Treatise on Coal Gas.

A standard text-book for the Engineers and Managers of Gas Works, and for all who are concerned
or take an interest in the manufacture and distribution of Coal Gas, and in the utilization of the
Secondary Products resulting therefrom; treating also of the Gas Engine, and of Gas Cooking and
Heating Appliances

In 3 Vols. Price per Vol., \$10. Sold either by Volume or in Sets.

A. M. CALLENDER & CO., 42 Pine St., N. Y.

RETORTS AND FIRE BRICK.

J. H. GAUTIER & CO.,

CORNER OF

GREENE AND ESSEX STREETS,
JERSEY CITY, N. J.

MANUFACTURERS OF

**Clay Gas Retorts,
Gas House Tiles,
Fire Bricks, Etc. Etc.**

Ground Clay, Fire Brick and
Fire Sand in Barrels,

J. H. GAUTIER. C. E. GREGORY. C. E. GAUTIER.

BROOKLYN

Clay Retort & Fire Brick Works,
(EDWARD D. WHITE & CO.)

Manufacturers of Clay Retorts, Fire Brick,
Gas House and other Tile.

VAN DYKE, ELIZABETH, RICHARDS & PARTITION STS.
Office, 88 Van Dyke St., Brooklyn, N. Y.

RETORTS AND FIRE BRICK.

LAGLEDE FIRE BRICK MFG. CO.,

MANUFACTURERS OF

Fire Brick, Gas Retorts,

AND

ST. LOUIS STANDARD SEWER PIPE.

Blast Furnace and Cupola Linings, every description of Fire
Clay Material, Fire Clay Flue Linings, Chimney Tops
Dry Milled and Crude Fire Clays, etc.

OFFICE AND DEPOT

901, 903, and 905 Pine Street,
ST. LOUIS, MO.

ESTABLISHED IN 1845.

B. KREISCHER & SONS,

OFFICE FOOT OF HOUSTON ST., E.R., N.Y.

Gas Retorts,

TILES, FIRE BRICK.

AND EVERYTHING IN THE FIRE CLAY LINE.

RETORTS AND FIRE BRICK.

MANHATTAN

FIRE BRICK & ENAMELLED CLAY

RETORT WORKS

ADAM WEBER.

CLAY GAS RETORTS

AND RETORT SETTINGS

FIRE BRICKS, TILES, ETC.,

Office and Works, 15th Street and Avenue C., N. Y.

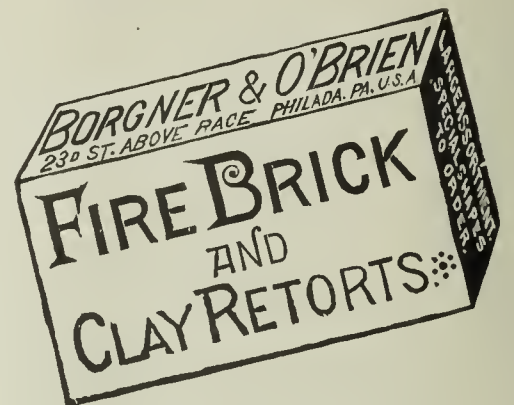

Works,
LOCKPORT STATION, PA.

—ESTABLISHED 1864.—

JAMES GARDNER, JR.,

Office, Rooms 19 & 20, Lewis Block,
PITTSBURGH, PA, P. O. Box 373.

Successor to WILLIAM GARDNER & SON.

Fire Clay Goods for Gas Works.

H. A. NORTON, No. 4 CENTRAL STREET, BOSTON, MASS., Agent for the New England States.

GEO. C. HICKS, CHICAGO CHAS. A. REED,
Pres. Sec. & Treas.

Retort and Fire Brick Co.,

MANUFACTURERS OF

Fire Clay Goods of all Kinds,

AND BEST QUALITY ONLY.

Regenerative Furnaces & Water Gas Goods.

45th St., Clark to La Salle, Chicago.

GEROULD'S IMPROVED RETORT CEMENT.

A Cement for patching retorts, putting on mouthpieces, and
making up all bench-work joints. This Cement is mixed ready
or use. Economic and thorough in its work. Fully warranted
o stick. For recommendations and price list address

C. L. GEROULD & CO.,

5 & 7 Skillman St., Brooklyn, N. Y.

Western Agent, H. T. GEROULD, Mendota, Ill.

**Parker-Russell
Mining and Mfg. Co.,**

CITY OFFICE,

Mermod-Jaccard Bldg., Rooms 307 & 308,
Broadway & Locust St., St. Louis, Mo.

PROPRIETORS OF THE

OAKHILL GAS RETORT & FIRE BRICK W'KS

Our immense establishment is now employed almost entirely in
the manufacture of

Materials for Gas Companies

We have studied and perfected three important points. Our re-
torts are made to stand changes of temperature, the strongest
heats of the furnace, and the abrasion of feeding and emptying.
We have the exclusive Agency for the West of the celebrated

**Kloenne-Bredel Full Depth and
Semi-Recuperator Benches,**

And also furnish and build

Our Own Styles Semi-Recuperator Furnaces
for the use of Coal or Coke as fuel.

THOS. SMITH, Prest. AUGUST LAMBLA, Vice-Prest. & Supt.

BALTIMORE

RETORT & FIRE BRICK CO.

MANUFACTORY AT

LOCUST POINT, BALTIMORE, MD.

Clay Retorts, Blocks & Tiles

**FIRE BRICK, FIRE CLAY,
AND FIRE CEMENT.**

Red and Buff Ornamental Tiles and Chim-
ney Tops. Drain and Sewer Pipe (from
2 to 30 inches). Baker Oven Tiles
12x12x2 and 10x10x2.

WALDO BROS., 88 WATER ST., BOSTON, MASS

Sole Agents the New England States.

Boston Fire Brick Works Manufacturers of **Gas Retorts and Settings**

Under the Personal Supervision of MR. GEO. C. HICKS late of Chicago.

Fire Clay Goods of all kinds. Akron Sewer Pipe, Lime, Cement, etc. Agts. for the Arc Gas Lamp & Governing Gas Burners.

Send for Circulars and Prices to

FISKE, COLEMAN & CO., Managers, No. 62 Congress Street, Boston, Mass.

HENRY MAURER & SON,

(ESTABLISHED 1856.)

**EXCELSIOR FIRE BRICK & CLAY
RETORT WORKS**

WORKS, Perth Amboy, N. J.

OFFICE, 418 to 422 East 23d St., N. Y.

**Clay Gas Retorts,
BENCH SETTINGS,
Fire Brick, Tiles, Etc.**

**FLEMMING'S
Generator-Gas Furnace**

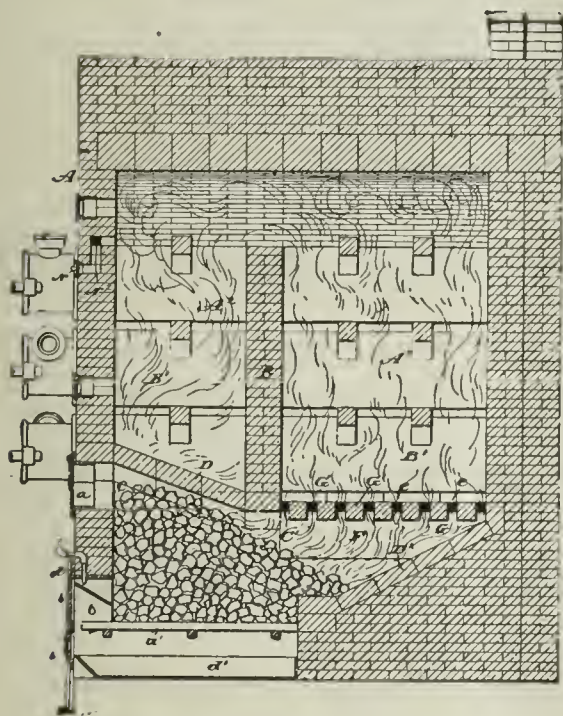

Materials furnished and Benches erected by

J. H. GAUTIER & CO., - Jersey City, N. J.

Address as above, or D. D. FLEMMING, Jersey City, N. J.

FRED. BREDEL,

CONTRACTOR FOR THE COMPLETE

Erection and Equipment of Gas Works.

SOLE PROPRIETOR OF THE

KLOENNE PATENTS

FOR NORTH AMERICA.

REGENERATIVE FURNACES.

(900 Retorts are now fired in America by the Kloenne-Bredel System.)

SELF-SEALING MOUTHPIECES.

(Over 800 Now in Use.)

Standard Condensers. Washer-Scrubbers.

TAR WASHERS FOR WATER GAS PLANTS.

(In use in the works of the Chicago Gas Lt. Co.)

GASHOLDERS.

Bredel's Automatic Gas Governor.

Refers, by permission, to Mr. Eugene Vanderpool, Newark, N. J.; Mr E. G. Cowdery, Milwaukee, Wis.; and Mr. Theo. Forstall, Chicago, Ills. For further information, address

FRED. BREDEL,

No. 208 East Seventeenth Street, N. Y. City.

SCIENTIFIC BOOKS.

KING'S TREATISE ON THE MANUFACTURE OF COAL GAS. Three vols.; \$10 per vol.

GAS MANUFACTURE, by WILLIAM RICHARDS. 4to., with numerous Engravings and Plates, in Cloth binding. \$12.

TECHNICAL GAS ANALYSIS. \$2.80.

GAS CONSUMER'S GUIDE. \$1.

A GUIDE TO GAS LIGHTING. 40 cents.

GAS MEASUREMENT AND GAS METER TESTING, by F. W. HARTLEY. \$1.60

GAS CONSUMER'S HANDBOOK, by WILLIAM RICHARDS, C.E.; 18mo., Sewed. 20 cents.

A PRACTICAL TREATISE ON GAS AND VENTILATION with Special Relation to Illuminating, Heating, and Cooking Gas, by E. E. PERKINS. \$1.25.

PRACTICAL TREATISE ON HEAT, by THOMAS BOX. Second edition. \$5.

GAS WORKS—THEIR ARRANGEMENT, CONSTRUCTION, PLANT, AND MACHINERY. \$8.

COAL; ITS HISTORY AND USE, by PROF. THORPE. \$3.50.

THE GAS WORKS OF LONDON, by COLBURN. 60 cents.

THE GAS FITTER'S GUIDE, Showing the Principles and Practice of Lighting with Coal Gas, by JOHN ELDRIDGE. 40 cents.

GAS WORKS, AND MANUFACTURING COAL GAS, HUGHES. \$2.20.

THE MANAGEMENT OF SMALL GAS WORKS, by C. J. R. HUMPHREYS. \$1.

MANUAL FOR GAS ENGINEERING STUDENTS, by D. LEE, 40 cents.

HOW TO MANAGE GAS, by F. WILKINS. Paper. 20 cents.

THE DOMESTIC USES OF COAL GAS, AS APPLIED TO LIGHTING, by W. SUGG. \$1.40.

DIGEST OF GAS LAW. \$5.

DISTILLATION OF COAL TAR AND AMMONIACAL LIQUOR by GEO. LUNGE. New Edition. \$12.50.

A TREATISE ON THE COMPARATIVE COMMERCIAL VALUES OF GAS COALS AND CANNELS, by D. A. GRAHAM 8vo., Cloth. \$3.

GAS COMPANIES DIRECTORY. \$3.

GAS VERSUS ELECTRIC LIGHT. 50 cents.

THE AMERICAN GAS ENGINEER AND SUPERINTENDENT'S HANDBOOK, by WM. MOONEY. \$3.

GAS ENGINE INDICATOR DIAGRAM, by W. E. AYRTON. Paper. 20 cents.

ILLUMINATING AND HEATING GAS, by W. BURNS. \$1.50.

TESTING PIPES AND PIPE JOINTS, by M. M. PATERSON. 80 cents.

DESIGNING WROUGHT AND CAST IRON WORK, by H. ADAMS. Paper. Three parts, 60 cents each.

NOTES IN MECHANICAL ENGINEERING, by H. ADAMS. \$1.

STRAINS IN IRONWORK, by H. ADAMS. With plates. \$1.75

The above will be forwarded by express, upon receipt of price. If sent by mail, postage must be added to above prices. We take especial pains in securing and forwarding any other Works that may be desired, upon receipt of order. All remittances should be made by check, draft, or post office money order.

A. M. CALLENDER & CO., 42 Pine Street, New York.

Newbigging's Handbook for Gas Engineers and Managers.

The present (the fifth) edition marks an important advance on those that have gone before. Considerable additions have been made to the text, and much of it has been re-written and otherwise improved. It extends to 524 pages, and contains 193 illustrations. **Price, Cloth, \$6.00.**

A. M. CALLENDER & CO., - - - No. 42 Pine Street, N. Y. City.

DAVIS & FARNUM MFG. CO.,

WALTHAM, MASS.

PRINCIPAL OFFICE AND WORKS, Waltham, Mass.

BOSTON OFFICE, Room 55, Mason Building, 70 Kilby Street.

SINGLE, DOUBLE,
AND
TRIPLE LIFT

Gas holders.

OF ANY CAPACITY.

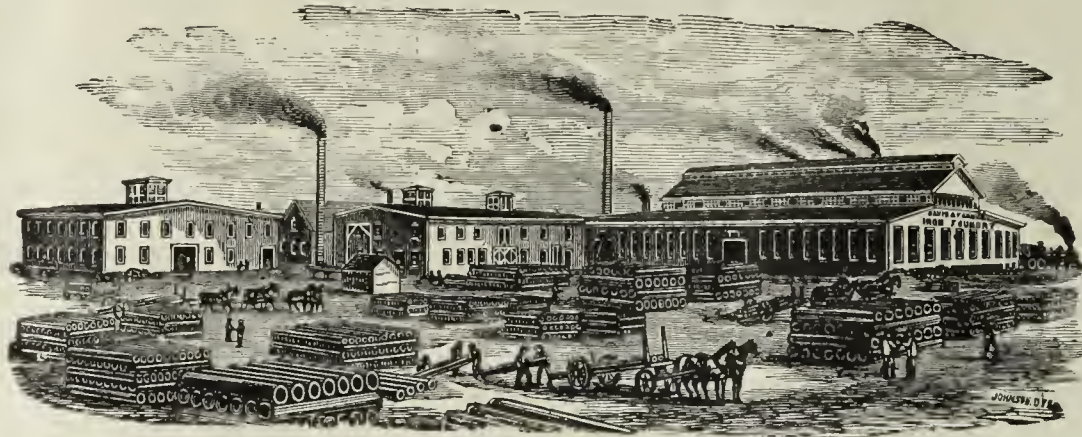

TUBULAR, PIPE,
AND
SINUOUS FRICTION

Condensers.

OF ALL SIZES.

IRON ROOF FRAMES AND FLOORS.

Purifying Boxes, Center Seal or Valve Connections, Bench Work.

Reversible Lime Trays.

SELF-SEALING AND PRESSED STEEL MOUTHPIECE LIDS.

Coke Barrows, Coal Wagons, and all Apparatus Requisite for a Complete Gas Plant.

— ALSO —

Gas and Water Pipe, Flanged Pipe,

Sugar House Work, and Special Castings of all Descriptions.

Established 1861.

Incorporated 1881.

KERR MURRAY MFG. CO.,

FORT WAYNE, IND.

Those who are in need of

Holdings of Gas Works Apparatus of any Description,

AND OF THE LATEST IMPROVEMENTS,

will find it to their interest to

GET AN ESTIMATE FROM US

before placing their order.

As we make a Specialty of this Class of Work, and are Practical Builders and Manufacturers of same,

with our long years of experience in the business,

WE CAN GUARANTEE YOU SATISFACTION.

Estimates, Plans and Specifications Furnished on Application.

BARTLETT, HAYWARD & CO.

Baltimore, Md.

Triple Double, & Single-Lift
GASHOLDERS.

Iron Holder Tanks.

ROOF FRAMES.

Cirders.

BEAMS.

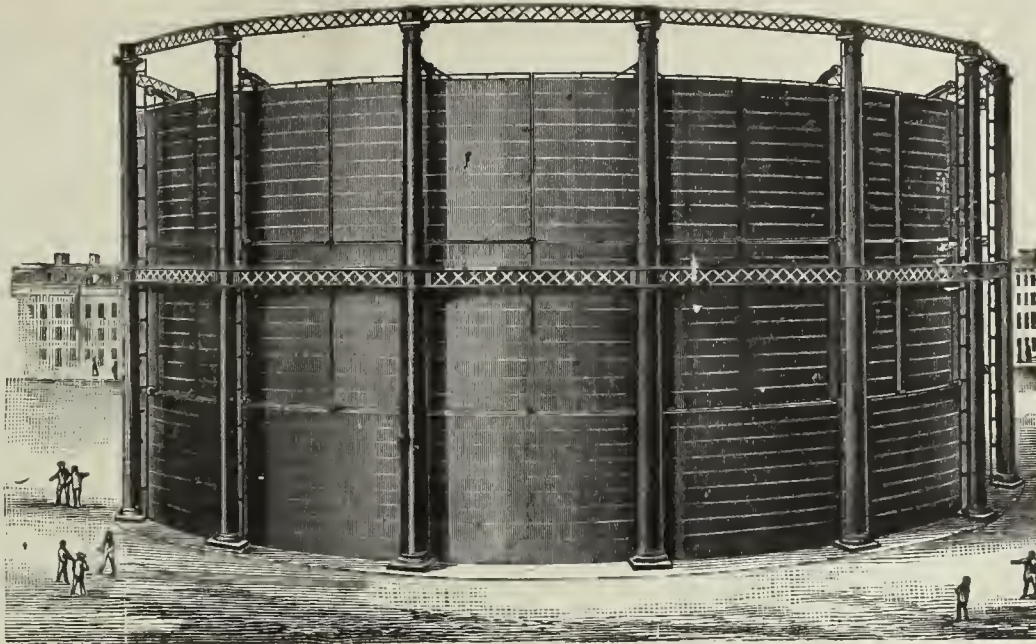

PURIFIERS.

CONDENSERS.

Scrubbers.

BENCH CASTINGS.

OIL STORAGE TANKS.

Boilers.

The Wilkinson Water Gas Process.

THIRTY-CANDLE, NON-CONDENSABLE, FIXED GAS. THE MOST SUCCESSFUL GAS PROCESS IN OPERATION.

Munich Regenerative Furnace, System Drs. Schilling & Bunte.

HAZELTON BOILERS.

Gas Works Designed and Constructed.

Pascal Iron Works. ESTABLISHED 1821. Delaware Iron Works.

MORRIS, TASKER & CO.,

INCORPORATED.

OFFICE, 224 SOUTH THIRD STREET, - - PHILADELPHIA, PA.

CONTRACTORS, BUILDERS, AND MANUFACTURERS OF

Gas, Water & Sugar Works

Bench Castings.

Condensers.

Scrubbers.

Purifiers.

Hyd. Carriages.

Iron Floors,

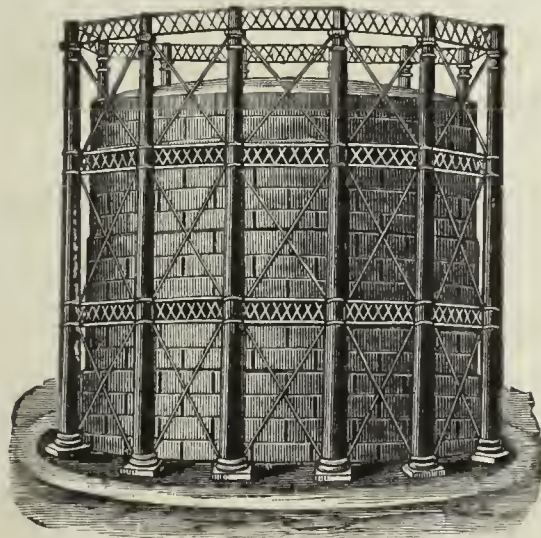

Iron Roofs.

Street Stops,

Valves, etc.

Stand-Pipes.

Water & Oil

Tanks, all Sizes.

Single, Double, and Triple-Lift Gas Holders.

SELF-SEALING RETORT LIDS. STAMPED STEEL RETORT LIDS.

Locomotive Water Columns, Filters, etc. Boiler Tubes, Wrought Iron Pipe & Fittings

Plans, Specifications and Estimates for all kinds of Machinery furnished on application.

Foundries & Works,
MILLVILLE, FLORENCE,
and CAMDEN, N. J.

R. D. WOOD & CO.,

Engineers,
Iron Founders,
and
Machinists.

400 Chestnut St., PHILADELPHIA, PA.

MANUFACTURERS OF

CAST IRON PIPE,

Gas Holders,

SINGLE, DOUBLE, AND TRIPLE LIFTS, WITH
OR WITHOUT WROUGHT IRON
OR STEEL TANKS.

PURIFIERS, CONDENSERS.

Scrubbers.

BENCH WORK.

Iron Floors and Roofs, Plate Girders.

Heavy Loam Castings.

HYDRAULIC WORK.

Lamp Posts, Valves, Etc.

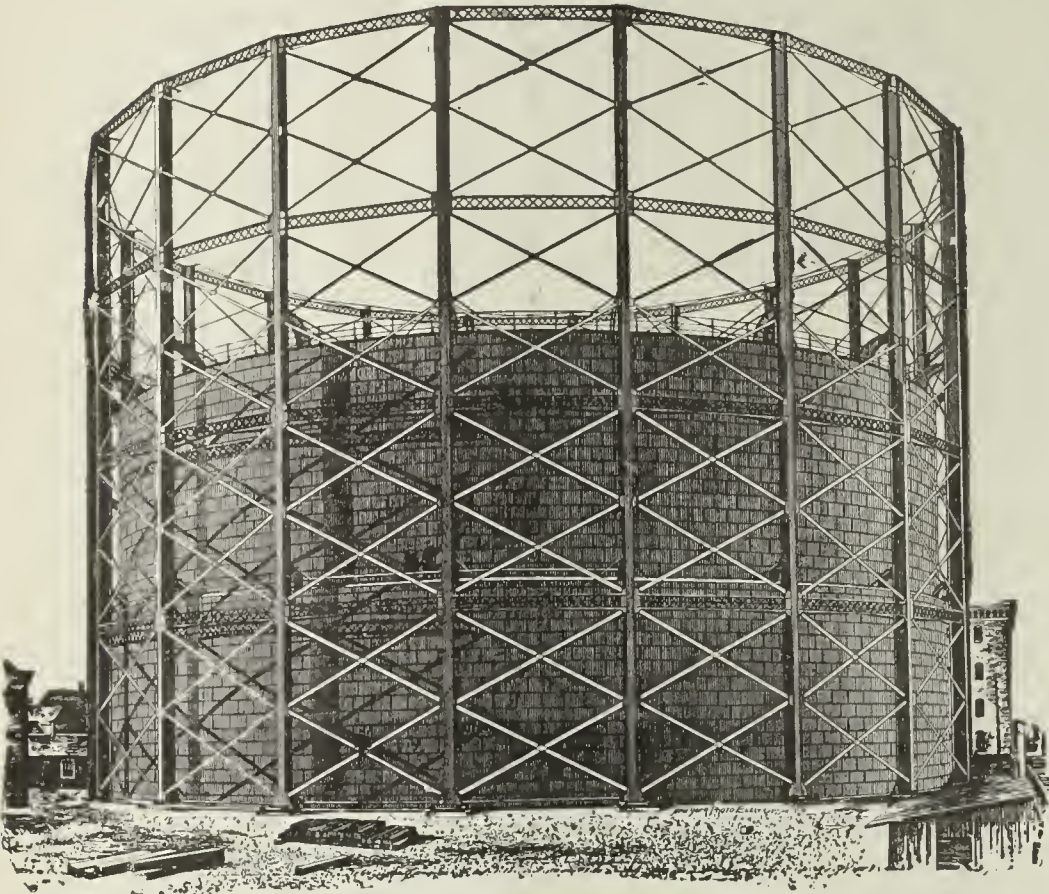

SMITH & SAYRE MFG. COMPANY,

G. G. PORTER, Prest.

245 Broadway, N. Y.

CHAS. W. ISBELL, Sec'y.

Machinery & Apparatus for Gas Works

Drawings, Plans, and Estimates Furnished for the Improvement, Extension, or Alteration of Gas Works, or for the Construction of New Works.

Mackenzie's Patent Rotary and Steam Jet Gas Exhausters, Governors, Compensators, Condensers, Washers, Scrubbers. Isbell's Patent Automatic Street Pressure Governor, Gas and Water Valves, Hydraulic Main Dip Regulator, Bench Castings, etc. Purifying Boxes and "Standard" Scrubbers. Isbell's Patent Self-Sealing Retort Doors

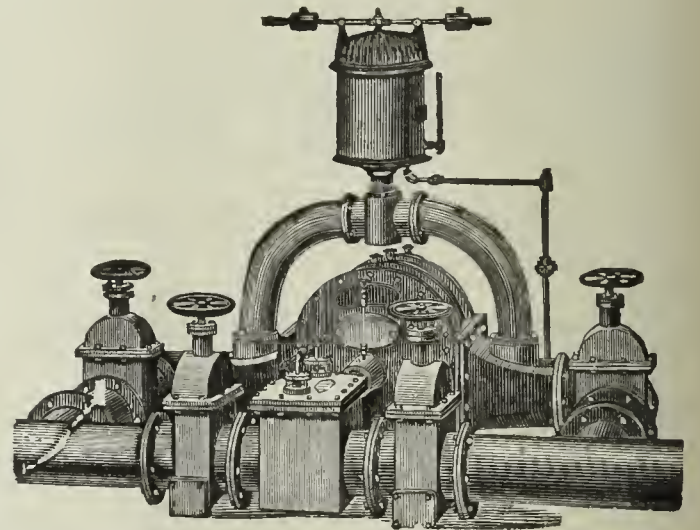

THE BRENNER SELF-SEALING RETORT DOOR.

Simple, Strong, and Durable.

CLOSES ABSOLUTELY TIGHT & IS LOCKED BY A CAM LEVER. ALL NECESSARY ADJUSTMENT FOR WEAR PROVIDED.

BUILT BY

SMITH & SAYRE MFG. CO.,

No. 245 Broadway, - - - New York City.

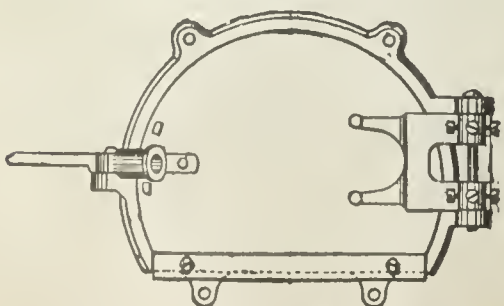

Brenner Self-Sealing Retort Door.

WILLIAM B. LUNDIE, Superintendent of the 42d Street Station of the Consolidated Gas Company, of New York, writes, under date of Jan. 4, 1889:

"We have 320 Brenner Self-Sealing Lids in use at this Station, built by the Smith & Sayre Mfg. Co. They require very little attention, and are the best of the kind that I have seen, giving entire satisfaction."

GAS WORKS APPARATUS AND CONSTRUCTION.

GAS WORKS APPARATUS AND CONSTRUCTION.

JAMES R. FLOYD & SONS,

(SUCCESSORS TO HERRING & FLOYD)

Oregon Iron Works,

W. 20th & 21st. Sts., bet. 10th & 11th Avs.,

NEW YORK CITY.

Engineers and Contractors

FOR THE

**CONSTRUCTION OF
GAS WORKS.**

MANUFACTURERS OF

All Kinds of Castings and
General Ironwork

FOR

GAS APPARATUS.

Bench Castings, Regenerative and Half
Regenerative Furnace Castings.

Condensers, Scrubbers, Purifiers,
Street Drips and Connections,

Valves,

Hydraulic Hoisting Purifier Carriage,
Self-Sealing Retort Lids, Improved
Valve Stand and Indicator,
Seller's Cement.

Plans, Specifications, and Estimates furnished for Construction
of New or Alteration of Old Works.

CONTINENTAL IRON WORKS.

THOS. F. ROWLAND, Prest.

WARREN E. HILL and CHAS. H. CORBETT, V-Prests.

THOS. F. ROWLAND, JR., Sec. & Tr

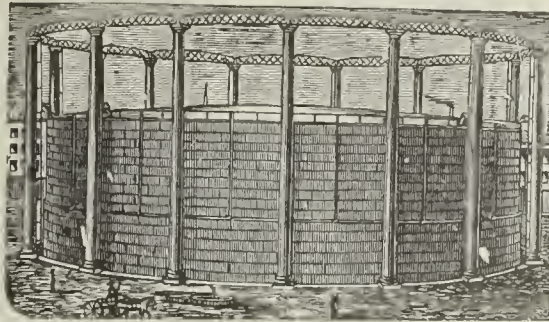

P. O. Station G., BROOKLYN, N. Y.

ENGINEERS AND MANUFACTURERS OF

Gas Holders

CONDENSERS, SCRUBBERS, VALVES,

PURIFIERS, SELF-SEALING RETORT LIDS

Hydraulic Mains,

And all other articles connected with the man-
ufacture and distribution of Gas.

H. RANSHAW, Prest. & Mangr.

WM. STACEY, Vice-Prest.

T. H. BIRCH, Asst. Mangr.

R. J. TARVIN, Sec. & Treas.

STACEY MFG. CO.,

MANUFACTURERS OF

Single and Telescopic Gasholders,

IRON ROOFS, BRIDGES, LAMP POSTS,

**Water and Oil Tanks, Coal Elevator Cars,
COKE CRUSHERS, BENCH CASTINGS,**

And all kinds of Wrought and Cast Iron Work used in the erection of Coal and Oil Gas Works
Rolling Mill Machinery and Heavy Castings a Specialty.

Foundry:

33, 35, 37 & 39 Mill Street.

Wrought Iron Works:

16, 18, 20, 22, 24 & 26 Ramsey Street:

Cincinnati, Ohio.

Bouton Foundry Co.,

FOUNDERS AND MACHINISTS,

CHICAGO, ILL.

Gas Works Apparatus,

PURIFIERS, CONDENSERS,

Bench Work

SPECIALS, LAMP POSTS,

SCRUBBERS,

Iron Roofs and Floors.

Plans and Estimates furnished for new works or extensions of
old works.

1842. **DEILY & FOWLER,** 1890

Laurel Iron Works.

Address, No. 39 Laurel Street, Philadelphia, Pa.

BUILDERS OF

GASHOLDERS,

Single and Telescopic.

HOLDERS BUILT 1884 TO 1888, INCLUSIVE:

- | | | | | |
|----------------------------|-----------------------------|---------------------------|--------------------------|------------------------|
| Newport, R. I. | Long Island City, N. Y. | Port Chester, N. Y. | Malden, Mass. | West Chester, Pa. (2d) |
| Portland, Oregon. | Macon, Ga. | New Rochelle, N. Y. | Paducah, Ky. | Lancaster, Pa. (3d) |
| Allegheny, Pa. (2d.) | York, Pa. | Salem, N. J. (3d) | Norwich, Conn. | Pac ary, Pa. (two) |
| Atlanta, Ga. (2d.) | Chester, Pa. | Omaha, Neb. (2d) | Seattle, W. T. | Mount Vernon, N. Y. |
| N.Y. City (Central Gas Co) | Hazleton, Pa. (2d.) | Lynn, Mass. (2d) | San Diego, Cal. | Binghamton, N. Y. |
| Lynchburg, Va. (2d.) | State Island, N. Y. | Little Rock, Ark. | Northern Gas Lt. Co., of | Concord, N. H. |
| Saylesville, R. I. | Saugerties, N. Y. | Irvington, N. Y. | New York, N. Y. | Dover, Del. (2d) |
| Rondout, N. Y. | Clinton, Mass. (Lan. Mills) | South Boston, Mass. | Westerly, R. I. | Calais, Me. |
| Atlantic City, N. J. | Chattanooga, Tenn. | Rye, N. Y. (2) | Williamantie, Conn | New London, Conn. (2d) |
| Augusta, Ga. | Galveston, Texas. (3d.) | Woodstock, Ont. | Montclair, N. J. | West Chester, N. Y. |
| Waltham, Mass. (2) | Omaha, Neb. | Malden, Mass. | Attleboro, Mass. | Bay Shore, L. I. |
| Mahanoy City, Pa. | Fort Plain, N. Y. | Staten Island, N. Y. (2d) | Santa Cruz, Cal. | Washington, D. C. |
| New Castle, Pa. | Brunswick, Ga. | Woodstock, Ont. | Erie, Pa. (2d) | |

WM. HENRY WHITE,

No. 32 Pine Street, - - - New York City.

ENGINEER AND CONTRACTOR FOR THE

ERECTION AND EXTENSION OF

GAS, WATER, AND ELECTRIC LIGHT WORKS.

Correspondence with Gas Companies contemplating extending or improving their Plants respectfully invited.
Plans and Estimates Furnished.

GAS COALS.

CANNEL COALS.

GAS ENRICHERS.

JAMES D. PERKINS.

PERKINS & CO.,

F. SEAVERNS.

228 & 229 Produce Exchange, New York.

Cable Address, "PERKINS, NEW YORK."

Post Office Box 3695, New York.

GENERAL SALES AGENTS FOR

The Youghioghenny River Coal Company's

OCEAN MINE YOUGHIOGHENY GAS COAL.

HON. W. L. SCOTT, Prest.

M. H. TAYLOR, Vice-Prest.

This Colliery is located at SCOTT HAVEN, PA., in the center of the Youghioghenny Gas Coal District, and produces the ONLY RELIABLE YOUGHIOGHENY COAL for gas purposes. (See Map on p. 87 of this JOURNAL, Feb. 16, '85.)

POINTS OF SHIPMENT,

Locust Point, BALTIMORE.

Pier No. 62, PHILADELPHIA.

Also, SOLE AGENTS for the

**BRECKENRIDGE CANNEL,
OF KENTUCKY.**

Within the past two years we have delivered this Cannel to over ONE HUNDRED COMPANIES IN THIRTY-THREE DIFFERENT STATES, and it is now in use in some of the large Gas Works

On the Continent and in South America,

where it successfully competes with the Australian Shale. It is the ONLY AMERICAN GAS CANNEL of sufficiently high grade to warrant EXPORTATION TO EUROPE AND SOUTH AMERICA, and it is the only economical substitute for OIL OR NAPHTHA. ONE GROSS TON will produce

10,000 Cubic Feet of 75 Candle Gas,	} equal to {	750,000 Candle Feet of Gas, and 26 Bushels of merchantable Coke weighing 900 Pounds
or 12,500 " " 60 " "		
or 15,000 " " 50 " "		

This is the ONLY GAS CANNEL that will produce a REALLY MERCHANTABLE COKE. It can be delivered in parcels of one carload or more to any point in the United States or Canada. Cargo shipments of any size required can be made from NEW YORK, PHILADELPHIA, BALTIMORE, or NEWPORT NEWS. Samples will be sent and particulars of price, etc., forwarded upon application to above address.

**JAMES & WILLIAM WOOD,
Gas and Cannel Coal Contractors,**

No. 40 St. Enoch Sq., Glasgow. No. 2 Talbot Court, London.

Proprietors of the BATHVILLE COLLIERIES (which produce the celebrated BOGHEAD CANNEL), Shields, Shieldmuir, Drumpeller, and other Collieries. This Firm offer

STANDARD CANNELS,

Unequaled as Gas Enrichers.

Analyses, prices, and all further information furnished on application to

Agency for U.S., Room 70, Nos. 2 & 4 Stone St., N.Y. City.

The Standard Oil Company,

REFINERS OF

NAPHTHA AND GASOLINES.

ALSO MANUFACTURERS OF

A Special Grade of Naptha for
Gas Companies**FOR ENRICHING COAL GAS.**

Correspondence solicited.

No. 43 Euclid Avenue, Cleveland, Ohio.

To Gas Companies.We make to order CAP BURNERS to burn any amount
under a stated pressure. Send for samples.Also, SERVICE CLEANERS, DRIP PUMPS, and STREET
MAIN PROVING APPARATUS.**C. A. GEFROER,**

248 N 8th Street, Phila., Pa.

COKE CRUSHERS.

GAS COALS.

GAS COALS.

Newburgh Orrel Coal and Coke Co.

MINERS AND SHIPPERS OF

STEAM, SMITHING, AND GAS COALS,
Foundry and Crushed Coke.

Home Office, 33 S. Gay Street, Baltimore, Md.

J. HARRY LEE, President.

Shipping Wharves, Locust Point, Baltimore.

The Despard Gas Coal Co.,

MINERS AND SHIPPERS OF

DESPARD GAS COAL,

AND MANUFACTURERS OF

COKE.

MINES, Clarksburg, Harrison Co., W. Va.

WHARVES, Locust Point, Baltimore, Md.

OFFICE, 225 E. German St., " "

ROUSSEL & HICKS, } AGENTS. } BANGS & HORTON,
71 Broadway, N. Y. } 60 Congress St., Boston.

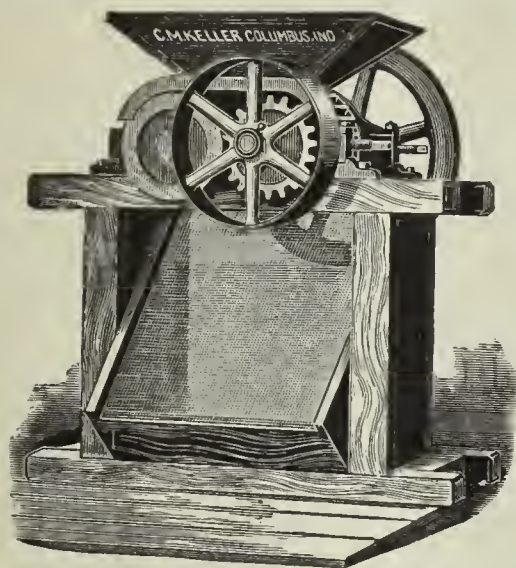

Keller's Adjustable Coke Crusher.

SIMPLE, STRONG, AND DURABLE.

C. M. Keller, Sec. & Supt. Gas Lt. & Coke Co. Columbus, Ind.

Correspondence Solicited.

King's Treatise on Coal Gas.

The most complete work on Coal Gas ever published.

Three Vols. Bound, \$30.

BOOKS.

DISTILLATION OF COAL TAR AND
AMMONIACAL LIQUOR.

By GEORGE LUNGE. Price \$12.50.

A TREATISE ON THE COMPARATIVE
COMMERCIAL VALUES OF GAS
COALS AND CANNELS.

By DAVID A. GRAHAM. 8vo., Cloth. Price \$3.

Orders for these books may be sent to this office.

A. M. CALLENDER & CO.,
42 PINE ST., N. Y. CITY

THE PENN GAS COAL CO.

OFFER THEIR

Coal, Carefully Screened & Prepared for Gas Purposes.

Their Property is located in the Youghiogheny Coal Basin, near Irwin and Penn Stations on the Pennsylvania Railroad, and on the Youghiogheny River.

Principal Office:

209 SOUTH THIRD STREET, PHILA., PA.

Points of Shipment:

Pennsylvania Railroad Piers; Greenwich Wharves, Delaware River; Pier No. 1 (Lower Side), South Amboy, N. J.

Chesapeake & Ohio Railway Coal Agency,

FOR THE SALE OF THE

Superior Kanawha Gas Coals, Cannelton Cannel,
Also, SPLINT AND STEAM COALS,

From the Kanawha and New River Regions, on the line of the Chesapeake & Ohio R'way.

C. B. ORCUTT, General Agent, - - No. 1 Broadway (Room 217) New York City.

FRANCIS H. JACKSON, Prest. EDMUND H. MCCULLOUGH, V.-Prest. CHAS. F. GODSHALL, Treas. H. C. ADAMS, Sec.

THE WESTMORELAND COAL CO.

Chartered 1854.

Mines situated on the Pennsylvania and the Baltimore and Ohio Railroads, in Westmoreland County, Penn.

POINTS OF SHIPMENT:

PHILADELPHIA, BALTIMORE, SOUTH AMBOY, N. J.,
WATKINS (SENECA LAKE), N. Y.

Since the commencement of operations by this Company its well-known Coal has been largely used by the Gas Companies of New England and the Middle States, and its character is established as having no superior in gas-giving qualities, and in freedom from sulphur and other impurities.

Principal Office, 224 South 3d St., Phila., Pa.

The American Gas Engineer and Superintendent's Handbook.

By WILLIAM MOONEY.

Consisting of Rules, Reference Tables, and Original Matter Pertaining to the Manufacture, Manipulation, and Distribution of Illuminating Gas.

350 Pages, Full Gilt Morocco.

\$3.00.

A. M. CALLENDER & CO., 42 Pine St., N. Y.

JOHN J. GRIFFIN & CO.,

Nos. 1513, 1515, 1517 & 1519 Race Street, PHILADELPHIA.

52 Dey St., NEW YORK.

75 N. Clinton St., (FRED. R. PERSONS, Mangr.) CHICAGO.

MANUFACTURERS OF

METERS FOR MEASURING GAS

IN ANY VOLUME.

Provers, Gauges, Registers, Etc., Etc.

EXPERIMENTAL APPARATUS FOR QUANTITATIVE AND QUALITATIVE ANALYSIS.

Careful and Prompt Attention paid to Repairing of all kinds of Meters and Apparatus.

Estimates Cheerfully Furnished.

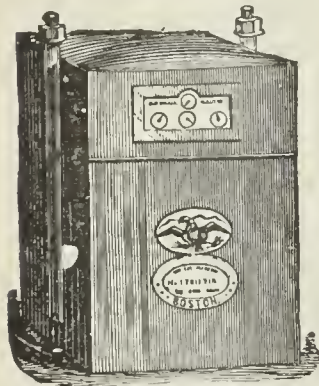

Dry Gas Meters.

With 40 years' experience and the best facilities for manufacturing, is enabled to furnish reliable work and answer orders promptly.

NATHANIEL TUFTS,

No. 153 Franklin Street, Boston, Mass.,

MANUFACTURER OF

DRY GAS METERS.

Station Meters of any Capacity.

Test and Experimental Meters, Pressure Registers, Pressure Gauges, Pressure and Vacuum Gauges.

METER PROVERS, PHOTOMETERS, STREET LANTERNS, ETC., ETC.

Patent Cluster Lanterns for Street Illumination.

HAROLD J. BELL.

BELL & JONES,

S. LEWIS JONES.

No. 12 North Ninth Street, Philadelphia, Pa.

Works at Royersford, Pa.

MANUFACTURERS OF

GAS METERS, STATION AND EXPERIMENTAL METERS,

Meter Provers, Pressure Gauges, and All Other Gas Appliances in Our Line.

WE REPAIR ALL KINDS AND MAKES OF METERS, AND THE WORK GUARANTEED.

High Pressure Meters for Natural Gas, in Iron Cases, guaranteed to stand 300 lbs. Pressure.

Gas Cooking and Heating Stoves, Hot Plates, Cake Griddles, Waffle Bakers, Boiling Stoves, Laundry and Tailors' Iron Heaters. Hotel and Cafe Ranges a Specialty.

Correspondence Solicited.

Estimates Furnished.

A. HARRIS.

E. L. HARRIS.

J. A. HARRIS.

Established 1849.

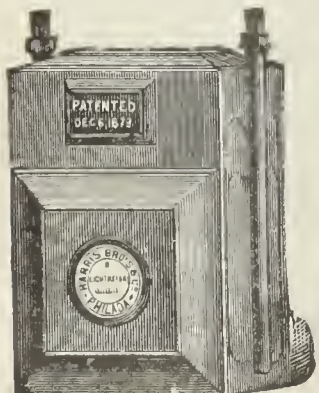

HARRIS BROS. & CO.,

Twelfth and Brown Streets, Philadelphia.

Manufacturers of Wet and Dry Gas Meters,

STATION METERS, METER PROVERS,

EXPERIMENTAL METERS, SHOW OR GLAZED METERS,

Pressure and Vacuum Registers, Gauges, Photometers, Drip and Bell Pumps, Etc., Etc.

PROMPT ATTENTION GIVEN TO ALL ORDERS. METERS THOROUGHLY REPAIRED. ESTIMATES FURNISHED FOR STATION METERS OF ALL SIZES. CORRESPONDENCE SOLICITED.

GAS METERS.

GAS METERS.

GAS METERS.

GEO. J. MCGOURKEY, Prest.

WM. H. MCFADDEN, Vice-Prest. (Phila.)

WM. N. MILSTED, Gen. Supt. and Treas. (New York).

WM. H. DOWN, Sec.

THE AMERICAN METER CO.

Established 1834.

Incorporated 1863.

WET AND DRY GAS METERS.

PRESSURE REGISTERS.

METER PROVERS.

STATION METERS.

PRESSURE & VACUUM REGISTERS.

PORTABLE TEST METERS.

EXHAUSTER GOVERNORS.

PRESSURE & VACUUM GAUGES.

EXPERIMENTAL METERS.

DRY CENTER VALVES.

CRESSON GAS REGULATORS.

AMMONIA TEST METERS.

GOVERNORS FOR GAS WORKS.

MARSLAND WATER METERS.

BAR & JET PHOTOMETERS.

Manufactories:

512 West 22d St., N. Y.

Arch & 22d Sts., Phila.

GAS STOVES.

SUGG'S "STANDARD" ARGAND BURNERS,
SUGG'S ILLUMINATING POWER METER,
Wet Meters, with Lizar's "Invariable Measuring" Drum.

Agencies:

177 Elm Street, Cincinnati.
244 & 246 N. Wells Street, Chicago.
810 North Second Street, St. Louis.
222 Sutter Street, San Francisco.

HELME & McILHENNY,

(Established 1848.)

GAS METER MANUFACTURERS,

Nos. 1339 to 1349 Cherry Street, Philadelphia, Pa.,

WET AND DRY GAS METERS. STATION METERS, EXPERIMENTAL METERS, METER PROVERS,
Center Seals, Pressure Registers, Governors, Indicators, Photometers, and all other kinds of Apparatus for use in Gas Works.

FOULIS' PATENT STATION AND DISTRICT GOVERNORS.

REPAIRING DEPARTMENT.—We employ a special force of skilled workmen repairing meters of all makers.

WM. WALLACE GOODWIN, President and Treasurer.

E. STEIN, Vice-President.

H. B. GOODWIN, Secretary and Superintendent.

THE GOODWIN GAS STOVE AND METER CO.,

Successors to W. W. GOODWIN & CO.

1012, 1014 and 1016 Filbert St., Phila., Pa.

113 Chambers St., New York City.

76 Dearborn, St., Chicago, Ills.

WALDO BROTHERS, Agents, 88 Water Streets, Boston, Mass.

MANUFACTURERS OF

DRY AND WET GAS METERS,

Station Meters (square, cylindrical, or in staves), Glazed Meters, King's and Sugg's Experimental Meters, Lamp Post Meters, etc., etc. Meter Provers (sizes 2, 5, and 10 feet), Pressure Gauges of all kinds, Pressure Registers, Pressure and Vacuum Registers, Pressure Indicators (sizes 4, 6, and 9 inch), King's Pressure and Vacuum Gauges, Dry and Wet Center Seals, Dry and Wet Governors, Exhauster Governors, Photometers of all descriptions. Lethby's Sulphur and Ammonia Test Apparatus complete. Also, Testing and Chemical Apparatus of all kinds, and of the most perfect description, for all purposes relating to Gas.

Manufacturers of the "SUN DIAL" GAS STOVES, for Cooking and Heating.

Goodwin's Improved Lowe's Jet Photometer.

Agents for Bray's Patent Gas Burners and Lanterns.

Special attention to Repairs of Meters and all Apparatus connected with the business. All work guaranteed first-class in every particular. Orders filled promptly.

G. B. EDWARDS, Manager, New York.

S. S. STRATTON, Manager, Chicago.

D. McDONALD & CO.,

GAS METER MANUFACTURERS.

(Established 1854.)

51 Lancaster St., Albany, N. Y.

34 & 36 West Monroe St., Chicago, Ill.

STATION METERS, EXPERIMENTAL METERS, METER PROVERS, PRESSURE & VACUUM REGISTERS, PRESSURE GAUGES, ETC.

Also STAR GAS STOVES, RANGES, and HEATING STOVES.

We use only the very best materials, and employ the most skilled labor, and by our long experience (36 years) and personal supervision of every detail, we feel justified in assuring the public that our goods will give perfect satisfaction. Every Meter emanating from our establishment will bear the State Inspector's BADGE, and will be fully warranted by us. Our Annual and Calendar will be sent to Gas Companies upon application.

WM. WALLACE GOODWIN, President.

E. STEIN, Vice-President.

H. B. GOODWIN, Sec. & Supt.

G. B. EDWARDS, Mang'r, New York.

S. S. STRATTON, Mang'r, Chicago.

THE GOODWIN GAS STOVE AND METER CO.,

1012-18 Filbert St., Phila., 113 Chambers St., N. Y., 76 Dearborn St., Chicago.

Agents, WALDO BROTHERS, 88 Water Street, Boston.

SOLE MANUFACTURERS OF THE

"SUN DIAL" GAS STOVES,

The Most Economical, Efficient, and Durable Gas Stove Made.

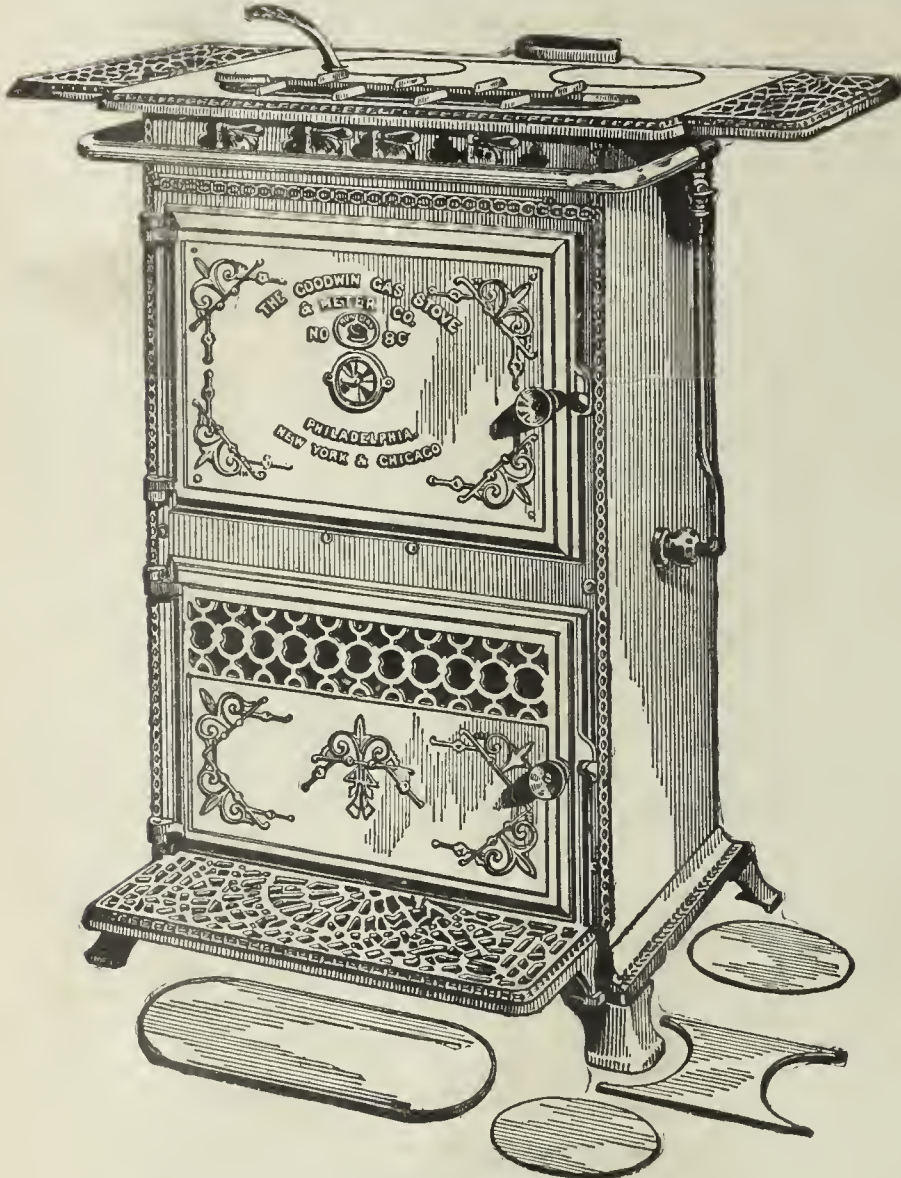

GAS COOKING STOVE, No. 8 C.

SIZE.

Stove.	Oven.	Roaster.	Top.	Length over Extension Shelves,
37 in. high.	12 in. high.	12 in. high.	24 in. long.	36 in.
20 in. wide.	17 1/2 in. wide.	18 in. wide.	21 in. wide.	
	12 in. deep.	13 in. deep.		

This Stove has four burners on top, and double oven burner. * Consumption of gas with all burners in use, 42 feet per hour, at 1 inch pressure. The top is made in sections, so that a greater variety of cooking utensils may be used. By lifting out the covers and crosspieces and putting in a suitable forked ring, which is sent with each stove, a wash boiler or other large utensil may be set over two burners. Our **No. 87 GRIDDLE** also fits in the same position. The roasting oven is provided with a cast-iron door.

All Fittings are Nickel-Plated.



GAS COOKING STOVE, No. 7 B.

SIZE.

Stove.	Oven.	Roaster.	Top.	Length over Extension Shelves,
31 in. high.	9 1/2 in. high.	10 in. high.	21 in. long.	32 in.
17 in. wide.	14 1/2 in. wide.	15 in. wide.	16 in. wide.	
	12 in. deep.	13 in. deep.		

This Stove has three boiling burners in the Top or Hot Plate, and one single oven burner.

This cut represents our New Style Cooking Stove. As will be seen, it has an ornamented cast-iron Base and Front, and extension shelves. The oven burner, which is atmospheric (unless otherwise ordered), is of an entirely new and improved pattern (patent). The ovens are of greater capacity than those of the old style. The Top, in conjunction with the Outlet Pipe, is designed to carry off all the products of combustion, if desired, but they are also supplied with a loose ring which converts it into an ordinary open top stove.

The consumption of this Stove is 35 cubic feet per hour at 1 inch pressure, with all Burners in use.

All Fittings are Nickel-Plated.

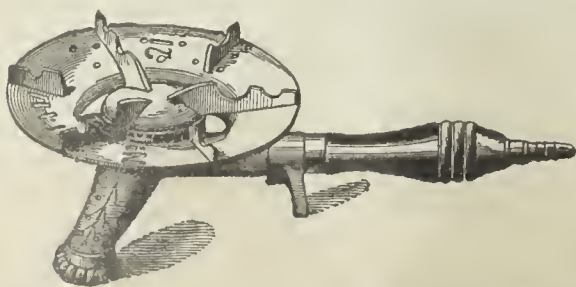

"RADIANT" BOILING STOVE, WITH REGENERATIVE BURNER.

Size, 6 1/2 inches diameter, 8 inches high. Consumption, 6 feet per hour at 1 in. pressure.

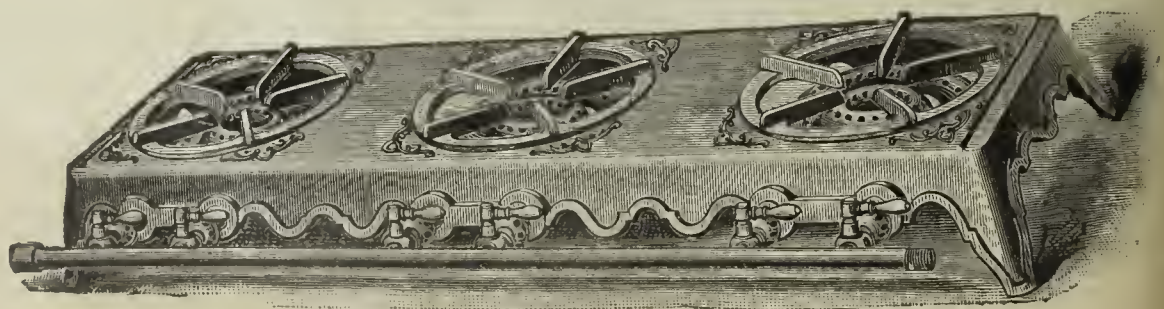

HOT PLATE, No. 111.

Size, 36 in. long, 12 in. wide, with three double burners, 6 taps. Consumption, with all burners in use, 36 cubic feet per hour, with 1 in. pressure. 1/2 in. supply pipe should be used where the pressure is 1 in. or over.

THE AMERICAN

GAS LIGHT JOURNAL

RODMAN & KENNY, N. Y.

PUBLISHING OFFICE No. 42 PINE STREET

DEVOTED TO THE INTERESTS OF ILLUMINATION, VENTILATION, WATER SUPPLY AND DISTRIBUTION, & GENERAL SCIENCE.

VOLUME LII.—No. 24.
Whole No. 784.

NEW YORK, MONDAY, JUNE 16, 1890.

{ \$3 PER ANNUM,
IN ADVANCE.

A. M. CALLENDER & CO., Proprietors. C. E. SANDERSON, Manager.
JOS. R. THOMAS, C.E., Editor. T. J. CUNNINGHAM, Asst. Editor.

ENTERED AT THE POST OFFICE AT NEW YORK, N. Y.
AS SECOND CLASS MATTER.

Published on each Monday of the year, at No. 42 Pine Street, N. Y.

Terms of Subscription, Including Postage.—For the United States and Canada, \$3 per annum. European countries, \$4.50 (19 shillings—22½ francs). All payments to be made in advance. Single copies, 10 cents.

Remittances should be made either by post-office order, express money order, registered letter, or bank draft on New York, payable to the order of A. M. Callender & Co.

Collections are invariably made directly from this office, for subscriptions, advertisements, etc. We have agents to solicit the same, but they are not authorized to receipt for money.

Correspondence.—Wishing to make this JOURNAL a gazette of intelligent discussion to those of our readers who may wish to gain or give information on the subjects to which its columns are devoted, correspondence is solicited for publication from all who make the study of those subjects a pleasure or a profession.

The American News Company, Nos. 39 and 41 Chambers street, New York, are agents for this JOURNAL. Newsdealers will send orders to them.

Books.—We will forward by express, at publisher's lowest rates, any book—scientific or otherwise—to any address in the United States or Canada. We would suggest to our patrons that to avoid the risk and expense consequent on sending us the money (we do not send books C.O.D.), that orders for books be sent us through the Purchasing Department of the American Express Company.

BRIEFLY TOLD.

MR. YORKE WRITES A BOOK.—It is with satisfaction and pleasure that we chronicle the appearance in the field of authorship of another gas man, who makes his bow to the fraternity in his new role from the precincts of beautiful and busy Brockton, Mass. To be more precise in our introduction of the last candidate for literary honors, in our especial field, we may say that the gentleman is Mr. Eugene H. Yorke, Superintendent of the Brockton (Mass.) Gas Company, and the title of his book—or pamphlet rather; for it is in paper covers, which inclose 24 pages of matter—is “The Essential Facts in Lighting with Kerosene, Gas, Electricity.” The principal divisions of the book, in respect to the subjects treated, are: The utility and value of lighting; the theory and laws of light; the advantages of brilliant illumination; means for producing light; the requisites in lighting; characteristics of kerosene, electricity, gas; points on electric wiring; cost of gas lighting; cooking by gas; heating by gas; gas for power; hints to gas consumers, etc. The matter is well arranged and intelligently composed, and the illustrations are both profuse and well drawn. Mr. Yorke has put the price of the pamphlet at 25 cents, but we presume a liberal discount from this could be secured in case copies were ordered, say, in lots of 50 or upwards. The Yorke idea, we presume, is that these pamphlets might be advantageously distributed to consumers by gas companies.

HOW THINGS ARE GOING ALONG AT IRONTON, O.—The following letter, from Mr. W. W. Prichard, Sec., Treas. and Supt. of the Ironton (O.) Gas Company, under date of June 10th, explains itself:

To the Editor AMERICAN GAS LIGHT JOURNAL: About December 25 the Ironton Electric Light Company started up their incandescent lights for the streets and private consumers. I have just made a comparison of the first four months of the year with the same four months of previous years, to see how much they were affecting our business; and if you think the figures of interest to your readers you may use them. During the four months of '89 we had 150 street lamps, Philadelphia schedule, up to midnight; in 1885 and 1875, Philadelphia schedule all night, though not so many lights.

Private Consumption.

1st 4 mos. of 1890	show a gain of 23.8 per cent. over same 4 mos. 1889
“ “ 1890	“ “ 73.2 “ “ 1885
“ “ 1885	“ “ 16.6 “ “ 1875

I go back only to 1885, as I took charge of the works on June 19, 1884. * * *

Total Sales.

1st 4 mos. of 1890	show a gain of 10.8 per cent. over same 4 mos. 1889
“ “ 1890	“ “ 33.7 “ “ 1885
“ “ 1885	“ “ 33.8 “ “ 1875

* * * Gas stoves are starting off well. I did not get away for the St. Louis meeting, much as I would like to have been there.

FURTHER HINTS FROM ALTON, ILLS.—A letter from Supt. Tracy, of the Alton (Ills.) Gas and Electric Light Company, under date of June 9th, says: “There is no let up in the gas business here. I have just closed a contract for a hot-tar scrubber with the Kerr Murray Mfg. Com-

CONTENTS.

An Asterisk (*) denotes an illustrated article.

EDITORIALS—

Briefly Told..... 837

Mr. Yorke Writes a Book—How Things are Going Along at Ironton, O.—Further Hints from Alton, Ills.—*The Western Gas Association Cup—Notes.

The Market for Gas Securities 838

Thirteenth Annual Meeting, Western Gas Association—Official Report, Revised by the Secretary—Continued from Page 809..... 838

The World's Fair and the Gas Associations, by Mr. Watton Clark—Discussion—Report of Committee on President's Address—Second Day, Morning Session: Report of the Committee on Nomination of Officers—Election of Officers—Introducing the President-elect—Report of Committee on Next Place of Meeting—Report of Committee on the Glimper Paper, Cincinnati, 1889—*Impressions of British Gas Works, by Mr. George T. Thompson—Discussion.

The “Express Company” System of Collecting Gas Accounts..... 846

A Brin's Process Company for New York 846

How to Manage Steam Engines, by B. Taylor..... 846

ITEMS OF INTEREST FROM VARIOUS LOCALITIES..... 847

Another Gas Scheme in St. Louis—Annual Meeting, Consumers Gas Company, Reading, Pa.—Cheap Gas, Salem, N. J.—Death of John E. Jeffries—Consolidated at Richmond, Ky.—Personal—Gasholder Damaged by a Lightning Stroke—Officers Chosen at Kansas City, Mo.—Hints from Atlantic City, N. J.—Cheaper Gas for Tonawanda, N. Y.—Annual Meeting, Camden, N. J.—Something from Hofflidsburg, Pa.—Governor Hill's Memorandum—U. G. I. Company vs. Milwaukee Company—To Dissolve the West Troy (N. Y.) Gas Company—End of the Gas War at Aurora, Ills.—Suing the Covington (Ky.) Company—Suing the Hyde Park Company—And Many Other Items.

pany, which I hope to have in place the last of next month. I have discontinued the use of native coal and am buying good Youghiogheny coal, and find that a good 18-candle coal gas gives the best results in Alton. I have 62 gas ranges in use and they are all giving the best of satisfaction. Not only so; but consumers are surprised at their small gas bills. This last is not a fish tale. We sell gas for fuel purposes at \$1.50 per 1,000."

THE WESTERN GAS ASSOCIATION CUP.—As said before, one of the most enjoyable features of the "outing" on the third day of the Western Gas Association convention was the racing card run off on the elegant track of the St. Louis Jockey Club. Good as the entire card was, of course, the gas men were most interested in the race for the "Western Gas Association Cup," which is a magnificent specimen of the silver smith's craft, and was designed by that celebrated St. Louis house, the

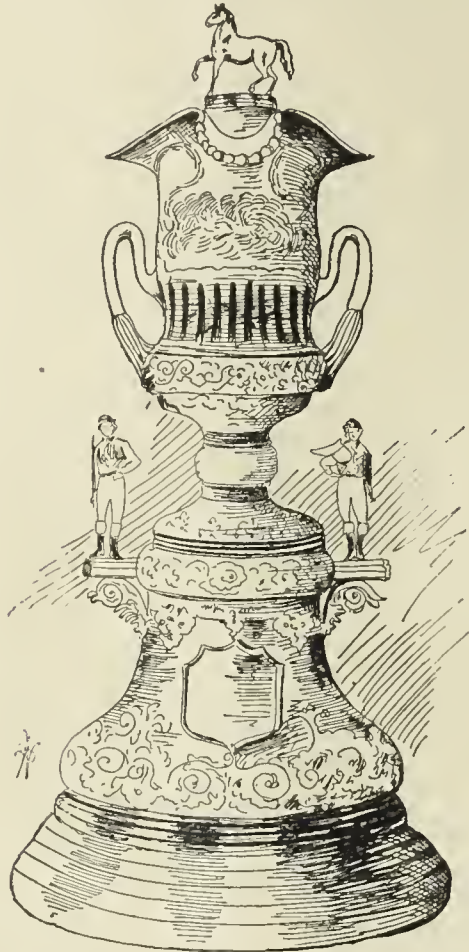

Mermod-Jaccard Jewelry Company. The cup was presented by the firms who contributed so generously to the entertainment of the Association and its guests. The race itself (the distance was $1\frac{1}{4}$ miles) brought out a good field of horses, and resulted in a stirring contest, at the end of which the judges first caught sight of the animal called Churchill Clark. In response to numerous queries about the appearance of the cup, we herewith print a very good illustration of it.

NOTES.—Mr. J. E. Rawn has been appointed Engineer of the Roanoke (Va.) Gas and Water Company.—At the annual meeting of the Newark (N. J.) Gas Light Company the following Directors were chosen: Eugene Vanderpool, Ira M. Harrison, Theo. Runyon, E. H. Wright, J. R. Emery, M. L. Ward, R. F. Ballantine, Franklin Murphy and Horace N. Congar.—The stockholders of the Louisville (Ky.) Gas Company have agreed unanimously to engage in the electric lighting business. The plant will be installed in buildings to be located on the site of the First Presbyterian Church on Green street.—The Pottstown (Pa.) Gas and Water Company elected the following officers: President, G. B. Lessig; Secretary and Treasurer, J. B. Maxwell.

The Market for Gas Securities.

Consolidated during the week about held its own at the figures last quoted. The range was narrow, and sales were restricted. The upward movement in Mutual still continues, 200 shares of that security having been sold at auction at $121\frac{1}{2}$ to $121\frac{3}{4}$. Higher prices are certain to be made in these shares, and speedily. It is possible that payment of the dividend on Chicago gas (due to-day) will be deferred for some days. Receiver Davis will likely appeal to the court for an order, and in the event of a favorable answer the Fidelity Trust Company will furnish him the funds to make the return to the shareholders. The stock is fairly strong at 53 to 54. We believe it to be a purchase. In Brooklyn shares nothing of moment is to be reported. Citizens gas still improves, being quoted at $85\frac{1}{4}$.

[OFFICIAL REPORT—REVISED BY THE SECRETARY—CONTINUED FROM PAGE 809.]

THIRTEENTH ANNUAL MEETING OF THE WESTERN GAS ASSOCIATION.

HELD AT ST. LOUIS, MO., MAY 21, 22 AND 23, 1890.

FIRST DAY—AFTERNOON SESSION—MAY 21.

Mr. Walton Clark, of Philadelphia, Pa., here read his paper on

THE WORLD'S FAIR AND THE GAS ASSOCIATIONS.

Our interest in the exhibit of mechanical appliances at the coming World's Fair will not be confined to articles, or the production of articles, immediately connected with the industry in which we are engaged. The gas engineer has an interest in every branch of engineering; and in almost every machine to be shown at Chicago, in 1892 or '93, will be able to find something to attract and educate him in his calling. No action upon the part of Gas Associations is necessary to insure an exhibit that will repay, in a purely business way, the money and time a member may give to visiting the World's Fair. Were there no gas industry, the immense collection of implements and machines would contain much that we now consider essential to a well built, economically operated gas plant; were there no American, or New England, or Western Association, to take action in the matter, there would yet be an exhibit of gas appliances such as has not had an equal on the American continent. The fact that adaptation, as well as invention, has had a share in supplying the mechanical features of a gas plant, *would* insure the former; the competition among manufacturers, and the importance to them of utilizing this, the first good opportunity of exhibiting their wares to thousands of possible purchasers, from all over the land, that has occurred in fifteen years, *does* insure the latter.

We are not then concerned as to the providing of an exhibit. Our responsibility is limited to providing, so far as we can, that there shall be such an arrangement of the things exhibited as will make the occasion of the greatest possible value to our members, and, through its effect upon the visiting public, to the owners of the properties we have in charge, and providing visiting gas men with such information and attention as shall make their trip to Chicago as enjoyable and inexpensive as may be. How may this best be accomplished? It is this question that I understand the committee desires to have presented by, and as it appears to, me, and discussed by you.

There are two points to be considered:

- 1st. What shall, or can, we do?
- 2d. How shall, or can, we do it?

What can we do toward insuring the greatest possible good to the visiting gas engineers and managers? Very much, I think, if the Associations act in concert; very little, if they do not. I think our action should be entirely independent of the manufacturers of appliances, up to the time of offering them room for the exhibition of their wares. Our aims and theirs are not similar. We desire an exhibit which shall instruct us, and give the visiting public a correct idea of the value of gas service in the generation of power, lighting of streets, and particularly, in domestic economy. The manufacturers' idea is to sell their goods. They will not be satisfied, naturally, to have us specify the number and class of articles of their make we may desire to have exhibited. Therefore, I would propose that we do not attempt to make our scheme cover the entire gas exhibit, but only such articles as refer to the utilization of gas for lighting, heating and the production of power; and the lighter appliances used in its manufacture and distribution. The latter to cover consumers' meters, cocks and valves of the smaller sizes, photometers, testing appliances, etc. Pictures and models of apparatus should also be included. Manufacturers could then have, if they so desired, their individual spaces in the general buildings and display their wares very much as if there were no gas Association's exhibit. This would probably be perfectly satisfactory to them. Lists of the appliances they had on show elsewhere, and the location of them, kept for distribution at the Association's headquarters, would be of mutual benefit. There is little doubt that the knowledge that there was to be a gas men's headquarters, where such wares as were shown would be appropriately grouped, and naturally command more attention from the people they desired to reach, than would isolated exhibits, would cause manufacturers to send their best goods cheerfully. The plan of grouping should insure the best attainable disposition of articles, both as affects convenience of inspection and efficiency of operation. The jealousies of manufacturers, and consequent annoyances, may probably be avoided by grouping all articles of a kind together; meters in one

room or stall, stoves in another, etc. By this means, charges, almost certain otherwise to arise, that one firm had been given a better position than another, would be avoided. The desirability of avoiding such jealousies, the recent unfortunate experience of the Gas Institute amply illustrates. In view of the importance of giving the various exhibitors an opportunity to explain the use and utility of their own wares, it is desirable that the Associations' headquarters be near that part of the building set aside for the exhibit of gas works appliances. It would be best located in the very midst of them.

If we have provided a suitable space convenient to the general gas exhibits, and the money appropriated to cover the expense of an attendant, the cost of gas, printing, etc., there should be no doubt of our ability to make a display of appliances, models, etc., creditable to the Associations, and of great value to the members of the fraternity. But we desire to do more. To realize the greatest benefit from the World's Fair for ourselves and our employers, we must impress upon the public mind the economy of the use of gas. To do this involves the exhibition of lighting, heating, cooking and power appliances, in operation for at least a part of each day. As already stated, the advantages possible to manufacturers from this display guarantee their hearty co-operation. Gas stoves and water heaters, with test meters and bakers' thermometers attached; engines with meters and Prony brakes; all ready for operation in a place certain to be visited by every man interested in gas works and visiting the Fair, and by tens of thousands of curious consumers of gas, would give the manufacturers more of an advertisement than they could otherwise obtain with an expenditure of an hundred times what this exhibit would cost them. The utilization appliances set conveniently for exhibition purposes, and in charge of a competent attendant; the spaces lighted at night by high power regenerative, incandescent and other forms of burners; everything arranged for convenient testing, and explained by cuts and text; these should make an impression upon a consumer that would result in good to the local company supplying him.

Having now considered what we desire to do in the way of an attempt to make the gas man enjoy and profit by his visit to the World's Fair, and to impress the layman with the superiority of our product for his uses, we come to the latter question: "How can we do it?"

The American Gas Light Association voted that the Council be directed to appoint a committee of seven, five from the Council and two from outside of that autocratic body. These will be appointed by the Council during this meeting of the Western Association. The New England Association has appointed a committee of three, two officers and an ex-president of the American Association. One of them will be on the committee of the latter. I suggest that the other Associations appoint committees of three; one, the chairman, to be one of the members of the larger committee of the American Association, and that the appropriations made be all turned into one fund at the disposal of the larger body. Each Association will have its representative in that body. No section nor interest can dominate the rest. To the attainment of any definite result of value a concentration of forces is necessary. It will cost more money to accomplish what we desire than any one Association will contribute, and if the effort is not all along one line the work done will amount to a little more than would result from the independent action of the American body. These men having control of the funds to be expended in carrying out our scheme, could best work through a sub-committee of three, at least one being resident in Chicago, to whom should be delegated the work of preparing plans and estimates during the coming year, to be submitted to the full body not later than January, 1891. These could be later endorsed by the Associations, if approved (the Council acting for the American, to save time), and appropriations made.

If space in the buildings were bespoken as soon as matters in Chicago are in condition to make it advisable, the proposed course would give the sub-committee ample time to perfect its arrangements after the appropriations had been made, and before the Fair opened.

I cannot estimate closely the probable cost of fitting up and maintaining the exhibit. The setting up of appliances exhibited should be at the expense of the owners. The preparing of the spaces, fitting up sitting rooms, providing conveniences for visitors, and paying salaries of two attendants, should be at the expense of the Associations. Probably five thousand dollars will cover the expense, if the Fair authorities do not charge for space.

Discussion.

The President—Any remarks upon the subject of the World's Fair, and the connection of our Associations with it—a subject in which we are all more or less interested—will be appreciated.

Mr. Harbison—Some action has been taken respecting the relation of

the gas industries to a World's Fair, to be held in Chicago, probably in the year 1893. As has been stated by Mr. Clark in his paper, the American Association have taken action by directing the Council to appoint a committee composed of five members of the Council and two members of the Association outside of the Council. The resolution provided further that this committee shall serve without compensation for services rendered, but that their actual expenses shall be paid from the funds of the Association. That action was taken at the meeting held last October. The New England Association, in February last, appointed a committee of three, and also passed a resolution that the committee should serve without compensation for services rendered, but that their actual expenses should be paid out of the funds of the Association. In the address of your President to-day allusion was made to this subject. Unfortunately I was not in the room when his address was read, and I do not know what action was taken upon it, but as the ordinary course is to refer the address to a committee, which course I take it for granted has been followed, I presume the committee will recommend to this Association what they think will be best for you to do in connection with the World's Fair. The Ohio Association will also undoubtedly take action in the same direction. It is exceedingly desirable that there should be co-operation amongst the different Associations, so that they may come together as a unit through such committees as may be appointed. In my opinion it would be well not to have this general committee too large. Some of the members will undoubtedly be members of the different Associations, so that the different Associations might name, for a part of their committee, those who have been named by other Associations. A committee of 10 or 12 would be more efficient than one of 25. I think the work of preparing, or of having prepared the exhibits of gas industries which may be made at the World's Fair, might be well relegated to such committee as may be appointed by the Associations.

It is probable that all the Associations will name on their committees men representing various sections of the country, and the various component parts of the membership of the Associations; and they will undoubtedly select men who would be likely to take a personal, as well as a professional, pride in the success of the exhibition. As a member of the committee appointed by the New England Association I cordially invite here any suggestions that may be made; and I would suggest that the matter of details might be left very largely discretionary with the committees, or with the general committee, when it is constituted; for I apprehend that the general committee selected, when gathered in council to discuss the measures to be adopted, will be able to reach a very careful conclusion and secure the best possible results. As to whether the exhibits shall be all in one department, or whether they shall be divided, as suggested by Mr. Clark in his paper, will be a question for careful consideration by the committee. They would undoubtedly be unanimous in every action which they might recommend to the World's Fair Committee. As representing the special industries which we have here, I shall be very glad if other members of the Association who feel interested in this matter will give expression to their views.

The President—The Committee on the President's address have not as yet reported, so that it is hardly fair or safe to prophesy what report they will make on the suggestion, relative to the World's Fair, that was contained in the President's address. The question, however, is now before the Association, and it is important that we should have a full expression by the members of this Western Association as to their wishes for the guidance and instruction of the committee, if we shall see fit hereafter to appoint a committee to co-operate with like committees from the American, New England, and Ohio Associations. I, therefore, trust that the members will not be backward in giving expression to their views.

Mr. Starr—I am much interested in this discussion. Mr. Clark proposes in his paper that the preparation of exhibits should be at the expense of the owners. I believe that, in all national affairs of the kind, the projectors or managers have had to pay for their gas also. Would it not be a good idea for some of the large companies who hold the right for different kinds of gas machinery to propose to light the building up on whatever days can be agreed upon. The electric light companies will most likely offer to do that. I have no doubt a moderate amount appropriated by the different Associations would fit up rooms where gas men would feel at home, and I would like to see that done. The \$500 in our treasury would not go very far towards the expense, but still it will help. I have no doubt the different patentees of water gas apparatus and the makers of gas apparatus generally could come to an understanding and bid for the lighting of that building, and then the electric light companies will come in and make their bids, which will afford an opportunity not before presented of showing the advantages of one sys-

tem over another. Let the gas section be a place for competition. The exhibition will be found of great interest and of great value to the country in the way of artificial lighting. I would be glad to see this thing carried out. I hope to see a splendid water gas apparatus put up in order to show the way it is done and the light that the product gives; also, a good coal gas works. If there is any virtue in coal gas yet—although I have quit it, and am wedded to water gas—I would like to see an exhibition of it. In the older times I stuck to the coal gas, but now I will take water in mine. I think such an exhibition will be interesting to the country at large. I also think it very desirable there should be some arrangement for a place where we can all go and feel that we have an interest. Most gas men in the country belong to some one of the Associations, and if he knows there is a place of comfort and of rest where he will be welcomed, he will feel more like going there than if he goes solely in the interest of some private or public corporation. I think the exhibition will be a great benefit to the gas interest. Some people declare that the electric light is the light of the future; well, it is an excellent thing, but I still think gas is a good thing yet.

Mr. Yuille—I can promise the cordial co-operation of the Chicago Gas Company in anything which the Association may see fit to do in Chicago.

Mr. Starr—Suppose that the Associations want to go into the plan I have suggested. In that event I would suggest that the gas companies of the United States contribute a small amount towards furnishing a place of entertainment for the members.

The President—I have permitted discursive remarks in order to ascertain the sense of the Association on this matter; but in order to accomplish what we want we must have an organization. If that organization is to be delegated to a committee, the committee can act only on their own judgment, and they would like to be guided by an expression of opinion from a large number of the members of the Association. For that reason we invite an expression from members as to what they would like and what they would object to. The Secretary suggests, if the Committee on President's Address is now ready to report, that the report be read, and that it be discussed in connection with the paper by Mr. Clark, which is still before the house. If Mr. Ramsdell is ready to report, and there is no objection, we will now hear the report.

Mr. Ramsdell then read the following

REPORT OF COMMITTEE ON PRESIDENT'S ADDRESS.

To the President and Members of the Western Gas Association: Your committee to whom was referred the President's Address beg leave to report as follows:

The address is so full and exhaustive in itself that it only remains for the committee to refer to certain portions for the purpose of emphasizing the suggestions made.

The remarks on the subject of the rise in the price of crude oil are of great importance to the large number of companies represented at this convention who are using it, and are worthy of careful consideration.

That part of the address which alludes to the subject of legislation is of paramount importance, and we cordially endorse the recommendation made, that in States affected or threatened with vicious legislation the gas companies of such States form a State organization for defensive action. And as such organization will in all probability result ultimately in State gas commissions, and as this Association stands committed to the wisdom of this policy, we, therefore, feel justified in recommending that this course be pursued.

Upon the remarks concerning the "Report of the Committee on Gas Companies' Accounts," we recommend that if the report be not adopted that it be referred to another committee whose duty it will be to further investigate the subject and submit another report at our next meeting; and, further, that if this report is adopted that another committee be appointed, who shall take up some other branch of this important subject and submit a report one year hence.

We desire particularly to emphasize the suggestions made concerning the collection of "data" with especial reference to the coming census. We would urgently recommend that as individuals we do all in our power to assist this work forward, by giving as complete details as possible, and would further recommend that the Secretary of the Association be instructed to communicate with the Superintendent of the Census and officially request him to obtain exhaustive information regarding the proportion of gas sold for purposes other than light.

In the matter of the World's Fair we recommend that the President appoint a committee of five to co-operate with similar committees appointed by the other Associations; that this committee shall have power to act for this Association in the arrangement of all details; that this

committee shall serve without compensation, but that this Association shall pay their actual expenses incurred while acting as such committee.

Respectfully submitted, GEO. G. RAMSDELL,
B. E. CHOLLAR,
ALFRED E. FORSTALL, } Committee.

On motion of Mr. Jenkins the report was received and adopted.

Mr. Shelton—Before this matter is closed up, as you have invited discussion, I would like to say a few words on the subject of the World's Fair. I am very sorry that the discussion has been left so largely to the Eastern members, who are not fully identified with this Association, and that they have to continue the discussion; and I am surprised that there has been so little discussion upon this topic, which ought to be one of the greatest interest to this Association. It seems to me it is eminently proper we should give all the information and all the suggestions for the guidance of the committee that we can possibly give. It would be presumptuous in me to attempt to occupy any time after what Mr. Clark has so well said, and after the remarks of Mr. Harbison as to the action of the various committees, for they are, of course, far better adapted to that than I. But I have considered somewhat with regard to the details of the exhibition, and as to the actual exhibit that we as gas people should make. There is no question but that we will have to hustle in order to make an exhibit which shall compare favorably with the electric light people. We may not like to admit it, but the fact remains the same. The electric light people will have an exhibit that they will certainly be most proud of. We, as gas people, do not wish for second place. We all wish to have a gas exhibit of which we shall be proud; and such an exhibit can be had only by the full co-operation of every one of us acting together. As to the question which Mr. Clark has touched upon, of co-operation between manufacturers connected with the gas industry and strictly gas engineers, of course, that needs to be considered carefully; but I think our committees will be able to handle such a matter in such a way as to secure the hearty co-operation of all hands, and in a way to secure a thoroughly satisfactory exhibit without arousing jealousies. I have no doubt the committee will be able to devise some plan by which that can be done. I think also very favorably of Mr. Starr's idea about illuminating the grounds so as to compete with the electric light people. There will be probably 8, 10 or 15 electric light systems, each one running full tilt, so that you will see the reflection in the heavens for miles outside of the city. I think the gas people should keep up their end of the exhibition, in respect to lighting the space that the illumination is required in. I think the committee should be instructed to let every manufacturer of gas apparatus put up a small plant according to his system. I do not mean to refer now specially to water gas, coal gas, rosin gas, or oil gas, but to every one of them; and we know that there are a great many new gas processes. There can be no better place to exhibit them than will be afforded at the World's Fair. We are all of us more or less interested in patented processes and appliances—of which there will doubtless be a full exhibit; but it seems to me that in addition to the exhibit of benches, retorts, generators, scrubbers, etc., we ought to have an immense volume of gas for illuminating the grounds. I would suggest that some arrangement be made for holders of sufficient capacity to store every kind of gas. Let the committee invite proposals for putting up holders, and let the expense be borne by the committee, or let that be a part of their exhibit; but let that holder receive the gas for all these different gas apparatus which may be used for illuminating the grounds. Let the piping extend from that all over the grounds. Let them make artificial gas, or furnish natural gas also if desired, and let that gas be supplied to illuminate the buildings and grounds, free of charge. There can be no question about having a perfect illumination if some such arrangement is perfected. With regard to the minor exhibits of drawings, models, etc., I think a special appeal ought to be made to every gas company to furnish something. A great many of us have something that would prove interesting to others. A great many of us have clever ideas of improvements in one direction or another, and they can be put in good shape. The thing can be made a success if we all pull together. If we do this we can get up an exhibition which will be creditable to ourselves, and will not suffer by comparison with the electric lighting exhibits.

Mr. Starr—I would like to see another test. Put up your gas apparatus—water gas or coal gas—light the whole building with it, and at the same time have an incandescent electric light put alongside of every gas burner, and let the place be wired for the electric light. Then alternate the lighting; that is, turn on the electric light, permit it to burn for some time, and then turn on the gas; first try one and then the other, which will permit everyone to say for himself which is the most effective. The electric light people always claim that their burners give more light than gas; but I notice when they replace gas burners with

the incandescent globes they always put in a room more globes than there were burners. Here in this room you notice that, when it was lighted with gas, they had 30 burners, but now that incandescent lamps are in vogue 36 bulbs are required. Here is a fair test. If the electric light is better than gas, let us have it. If you will make such a test as this you will draw every gas man in the country to see it; and you will draw a large number of other people to see it. The people are the ones who are really interested in this matter, since the people are the purchasers of what we have to sell. The manufacturers would like to know which light is the best, so that they may know which will please the public best. You can give a satisfactory test by turning out every gas burner in the house and then lighting the same amount of incandescent lights; then put out the electric lights and light up your gas burners. Such a test as that will settle the matter to the satisfaction of consumers.

Mr. Dunbar—I believe every member of this Association has an interest in and desires to have a satisfactory exhibit of gas appliances at the World's Fair. We are all most anxious that such an exhibit shall be a success, and we have confidence that any committee that may be appointed will successfully carry the matter into execution. About the only thing that we as individual members have to express our ideas on is the matter of finance. As I understand it, we now have about \$100 in our treasury. The probable expense to the Western Association will be about \$1,000 or \$1,200. Would it not be well for some of the gentlemen here to consider the best means to raise the amount of money that we will be required to contribute? I merely offer this as a suggestion for the consideration of the members. It might be well to appoint a committee to report at this meeting upon the best means to raise the amount required.

Mr. Jenkins—I think it will be impossible for us at this meeting to do what Mr. Dunbar suggests. In the first place, we cannot tell how much of an exhibit we will have. If we adopt the suggestion of Mr. Dunbar we shall have to call upon the companies for quite a large subscription to the gas fund, for the expense will go up into the hundreds of thousands instead of being a few thousands. Until we find out what we are going to do it will be impossible for us to know how much money we want to raise. There is no doubt but that the general committee will take those matters into consideration, and between now and the next annual meeting of the Association they will be able to find out, and can then advise us how much will need to be raised; and then we will raise it.

The President—I understand that the proposition is that the Association as an Association does not bind itself for anything more than the actual expenses incurred by the committee. If the committee after investigating the matter come back next year and report that it is desirable the Association shall raise a certain amount of money, the question will then come before us for action. Until that time the financial question does not concern us, other than so far as defraying the actual expenses of the committee. The object of inviting remarks on the subject at all was for the instruction of the committee. That committee will want one of two things. They want the advice of the Association as to what they shall do, or they want an unlimited privilege to use their own judgment as to what is best for the Association to do. Perhaps it may be best that I should name that committee at this time. I will appoint on that committee Messrs. George G. Ramsdell, A. W. Littleton, A. E. Boardman, A. E. Forstall, and Walton Clark. Now, if the Association is satisfied with the membership of the committee, and will delegate to them the power to act as representing the sentiment of the Association, the committee will use their best judgment; or, if you are not prepared to delegate that to the committee, they would certainly like to have a further expression as to the wishes of the Association.

Mr. Ramsdell—In adopting the report brought in by the Committee on President's Address the Association has already taken action in this matter. We recommended in the report that this committee be appointed with power to act for this Association in the arrangement of all details. Of course we do not yet know anything about what is to be done; but we all recognize that there must be a vast amount of work done before this exhibition, as we are talking about it to day, can be put on its feet. As to the money matters, we do not yet know anything about that; and, as it seems to me, we cannot arrive at any just idea of it until this joint committee of the various Associations get together and formulate some plan of action. Then it will become necessary for them to report back to the various Associations. The committee intended by their report to give to this committee, which has now been appointed by the Chair, power to act for this Association, in conjunction with the other committees, in the arrangement of details.

The President—As Mr. Ramsdell made the report he certainly knows

what it contains; but I imagined that the report read, "subject to the approval of the Association," and that the report of the committee would have to be referred back for the approval of this body. If that were so the committee could not act very strongly until we met in convention again and confirmed the action which they had taken in the meantime. Now, if the Association is prepared to endorse the report as recommended, and the report gives the committee the right to judge for the Association, and if the Association is further satisfied with the committee as named, I will put the question. I will first read the report of the Executive Committee as to the World's Fair:

"We recommend that the President appoint a committee of five to cooperate with similar committees appointed by other Associations, and that this committee shall have power to act for this Association in the arrangement of all details, and that this committee shall serve without compensation, but that this Association shall pay their actual expenses incurred while acting as such committee."

The report of that committee has been adopted. If there is no objection to the committee as named, they will serve. A motion was offered some time ago by Mr. Egner that a vote of thanks be tendered to Mr. Clark for his paper. Are you ready for that question. [Adopted.]

Mr. Somerville—I observe that in the report gas was the only thing mentioned. We must remember that gas is not the only thing we make. I think some attention should be given to the products—to what we derive from the coal tar. You have all noticed the drawing which is hung on the wall—a tree illustrating what is taken from the coal. It is a very beautiful idea, and I think it could be illustrated very nicely in a series of bottles showing the various dyes extracted from tar, and also the extracts from ammonia. I would suggest that these bye-products be taken into consideration by the committee.

The President—I suppose all that would come under the head of "details," if the committee took hold of the matter. I am requested by Mr. Egner to again call the attention of the delegates to the exhibition of gas appliances that will be held on Eleventh street this evening. The Laclede Gas Light Company has gone to considerable trouble and expense in the preparation of this exhibit, and it is well worthy of a visit and an examination by each member. I hope that the attendance there to-night will be sufficient in numbers to repay in a measure the members of the local committee and others who have arranged for the exhibit of manufactures, for the trouble and expense to which they have gone.

Mr. Harbison—The Council of the American Association are to hold a meeting at this house to-night to consider the question of the appointment and to name their committee for the World's Fair. When we have acted we very much desire that the committee you have named by authority of this Association should join with us for consultation on this general subject. If the members of the committee that you have named will kindly make their arrangements for this evening so that they can give us an hour of their time, we should be very glad to have the five gentlemen whom you have named as members of this committee confer with us. With your permission I will say a single word further: That, so far as I know the opinions of the members of the New England Association upon this subject, and knowing the personnel of the members of this Association appointed by the President, and knowing something of the personnel of the Council of the American Association, I think I can assure every gentleman here that the gas industries shall be well taken care of in Chicago. I apprehend it will be in the opinion of your committee, and of the general committee, necessary to ask the committee of the World's Fair for at least one quarter of their entire territory. (Applause.) We have the assurance of the Manager of the Chicago Company that all that can be done by the Chicago Gas Light Company towards favoring the object in view shall be freely given by them. We know their ability, and hence there need be no fear on the part of any gentleman that the gas industry will not be well taken care of. It has been suggested that the natural gas business also should be taken care of. The edification which I have had in attending your meetings for the last eight or ten years gives me abundant assurance that the natural gas exhibit will be a success. I have always been highly gratified to listen to the eloquence and freedom with which the natural gas comes forth in your discussions. I do not believe that any part of the gas industry will be neglected. The residuals will be well taken care of. I was told not long ago it was probable that gas works would soon be run not for the making of gas, but for the making of residuals. So that we will have the residuals to take care of. I am quite sure all the manufacturers will be only too ready to send you everything of interest to them for exhibition at Chicago; and, therefore, I think that at least one-quarter of all the territory which will be devoted to the World's Fair Exhibition will be required for gas appliances.

The Association then adjourned to Thursday, May 22, 1890, at 10 A.M.

SECOND DAY—MAY 22—MORNING SESSION.

The Association was called to order at 10 A.M.

The President—The business of the day will be introduced by the reception of the

REPORT OF THE COMMITTEE ON NOMINATION OF OFFICERS.

Mr. Jenkins—Before I read this list, I wish to make a statement with regard to the Presidency for the present year. We all understand that Mr. Faben was advanced from the first Vice-Presidency to the position of President by reason of the death of President King. Considering that matter the committee concluded that inasmuch as he had served as President for this year it would not be necessary to elect him as President for another year. We suggest that when the records are made up Mr. Faben's name be placed upon the list of ex-Presidents. We think that is all that is required.

Your committee appointed to nominate officers of this Association for the year 1891 report the following :

President.—Frederic Egner, St. Louis, Mo.

First Vice-President.—E. G. Cowdery, Milwaukee, Wis.

Second Vice-President.—B. E. Chollar, Topeka, Kas.

Secretary and Treasurer.—A. W. Littleton, Quincy Ill.

Directors.—Edward Lindsley, Cleveland, O. ; M. N. Diall, Terre Haute, Ind. ; W. H. Odiorne, Springfield Ill. ; C. W. Butterworth, Florence, Ala. ; E. H. Jenkins, Columbus, Ga. ; John Gimper, Leavenworth, Kas. ; K. M. Mitchell, St. Joseph, Mo. ; I. C. Baxter, Detroit, Mich. ; I. S. Post, Chattanooga, Tenn.

J. D. THOMPSON,	} Committee.
E. H. JENKINS,	
J. T. LYNN,	
R. H. CANBY.	

ELECTION OF OFFICERS.

Mr. Ramsdell moved that the report of the committee be accepted, and that the chairman of the committee cast the ballot of the Association for the election of the officers named. This having been done, the President declared that they were duly elected officers of the Association for the ensuing year.

INTRODUCING THE PRESIDENT-ELECT.

The President—It gives me great pleasure, gentlemen of the Association, to introduce to you, as my successor in the office of President, Mr. Egner. (Applause.)

Mr. Egner (President-elect)—Mr. President, and gentlemen of the Western Gas Association : I was scarcely prepared for the mark of distinction which you have conferred upon me. I expected that my friend Mr. Faben would be elected to this office, until quite recently. I cannot help feeling highly honored by this expression of your confidence, because I know there is hardly a member of the Association who is not as able as I am to fill the Chair, which has always heretofore been so well filled. I will not attempt to make a longer speech because I fear that if I do, you will be sorry that you elected me. Gentlemen, I thank you. (Applause.)

REPORT OF COMMITTEE ON NEXT PLACE OF MEETING.

The President—We will next hear the report of the committee appointed to select the next place of meeting.

Mr. Cowdery—The committee, after carefully canvassing among the members, and obtaining an expression of their wishes, have determined to recommend that Louisville, Ky., be selected as our next place of meeting.

Mr. Egner—Before that report is adopted I would like to say that I have been informed we have with us a gentleman from St. Paul who desires to extend us an invitation to meet there next year. Louisville seems to be a pretty warm place for meeting in the middle of May, although I think we ought to go there some time. I understand that we are promised an invitation from the city authorities of St. Paul and Minneapolis, and I think we had better accept the invitation, if we have one.

The President—I will state that the selection of St. Paul was considered, but as no formal invitation had been extended, other than a verbal one, the committee were forced to decline to further consider it, as I understand they had in a measure committed themselves to report in favor of Louisville. The question is on the adoption of the report of the committee in favor of Louisville.

(The report was adopted.)

REPORT OF COMMITTEE ON THE GIMPER PAPER, CINCINNATI, 1889.

The President—We will now have a report from the committee specially appointed to consider the suggestions contained in a paper read

by Mr. Gimper last year at Cincinnati, entitled "The Education of the Gas Engineer and Superintendent."

Mr. Gimper—Before reading the report I wish to say that the chairman of this committee was our worthy President, the late Mr. King. His untimely death, however, disarranged the plans of the committee, and, as my time has been so much occupied during the past year, I fear that the report will be all too brief. Our action, however, was based on the following :

Your committee to whom was referred the further investigation of the subject-matter of a paper entitled "The Education of the Gas Engineer and Superintendent," beg leave to submit the following correspondence as their report :

CHEMICAL LABORATORY, UNIVERSITY OF MICHIGAN, }
ANN ARBOR, MICH., March 5, 1890. }

MR. JOHN GIMPER, Supt. Leavenworth Gas Light Company, etc. :

Dear Sir—In January I received from you a letter of inquiry, in the interest of the Western Gas Association, as to opportunities for technical training in gas engineering at this Institution. The President of this University received a letter on the subject. The matter has been under consideration, at request of the President, by Prof. M. E. Cooley and myself. We have had here all the necessary branches of instruction and facilities of experimentation, and your very pertinent and suggestive inquiries have caused us to *organize* these branches and facilities, by planning out an advisory course for students—indeed, two advisory courses, one of two years' extent and one of four years' extent. These facilities are, however, separately available, under the conditions stated herewith. I inclose a brief descriptive announcement.

Very truly yours,

ALBERT B. PRESCOTT,
Director Chem. Laboratory.

Applied Science for Gas Engineering. A College Course of Two Years' Extent. (University of Michigan, Ann Arbor.)

Chemistry.—Laboratory work and lectures throughout two years, as follows :

- General chemistry, first year, first semester.
- Qualitative analysis, first year, second semester.
- Quantitative analysis, second year, first semester.
- Organic chemistry, second year, first semester.
- Analysis of gas, coal, and tar, second, year, second semester.

Physics.—Through one year, as follows :

- Mechanics, light, etc., first year, first semester.
- Heat, etc., etc., first year, second semester.

Mechanical Engineering.—Through one year, as follows :

- Mechanism, steam, and gas engines, second year, first semester.
- Machinery, second year, second semester.

Drawing.—Preparatory to mechanics, as follows :

- Geometric drawing and mechanics, first year, first semester.
- Descriptive geometry, first year, second semester.

Surveying.—Sufficient to establish levels, etc., etc.

Mathematics.—As needed, in addition to entrance requirements, to prepare for physics and for mechanics. In first year.

Other studies are accessible. This order of studies can be modified to suit the advantage of the student. As here given it presents the amount of work that can be done in two collegiate years of nine months each. Applicants for admission must pass the entrance examination for the courses of engineering in this University, as follows : In the use of the English language ; in geography ; in arithmetic, algebra, and geometry ; in history ; in natural philosophy ; and in chemistry. For particulars, see the calendar of the University. But persons over 21 years of age, able to show that they have a good knowledge of English, and if found prepared to pursue profitably the studies they desire to take up, are received without the above-named examinations.

A college course of four years' extent, for gas engineering, and leading to the degree of Bachelor of Science in Chemistry, is offered in this University. All the branches of the two years' course as given above are comprised in this course, with additional technical studies, by laboratory work and lectures. The laboratories of chemistry, physics, and engineering are employed. Three years' work in chemistry is obtained. The French and German languages are included, as are brief courses in geology and mineralogy. A schedule of technical studies for the gas engineer takes the place of the elective studies for B.S. in chemistry. Further information can be obtained by addressing the Director of the Chemical Laboratory, University of Michigan, Ann Arbor, Mich.

UNIVERSITY OF MICHIGAN, ENGINEERING LABORATORY,
ANN ARBOR, March 17, 1890.

JOHN GIMPER, ESQ., Leavenworth Gas Light Company, Leavenworth, Kan.:

Dear Sir—Replying to your favor of 20th January, bearing upon question of establishing a course in gas engineering. I would say that I conferred with Dr. Prescott about the same, and that he agreed to write you further in regard to it. Assuming that the question was one more chemical than mechanical, the matter rests in his hands. In my opinion a course could be easily established here filling the bill so far as my knowledge of the subject suggests. Yours very truly,

M. E. COOLEY, Prof. Mech. Engineering.

After receiving this hearty response to our appeal from a University of such high reputation, we feel that it would be ungrateful, to say the least, toward our respondent to seek or encourage other correspondence upon this subject before reporting the same to this Association.

By a careful perusal of the descriptive announcement of the University of Michigan it will be seen that it offers two full and comprehensive courses for technical training for gas engineers and superintendents; and in view of this we would recommend that the influence of this Association be extended for the hearty and cordial support of this Institution.

All of which is respectfully submitted.

JOHN GIMPER,
B. E. CHOLLAR,
GEO. T. THOMPSON, } Committee.

Discussion.

The President—You have heard the report of the Committee. Are there any remarks?

Mr. Forstall—I would like to ask Mr. Gimper if the instruction there will have any relation to gas works, or whether it will be purely with regard to the subjects mentioned, chemistry and engineering, without reference to gas works, or will the studies have special reference to their use in gas works?

Mr. Gimper—I take it the studies which are here offered would be sufficient to give a man sufficient scientific knowledge to subsequently apply in practice. I am inclined to think the title of the paper has probably led to a misunderstanding. You may have thought that "The Education of the Gas Engineer" had reference solely to the matter of education; but if you read it carefully you will see that I mention particularly the necessity of proper *training* in connection with the education. In order to be successful in our business, men must be both trained and educated. By "training" I mean the practical part of it. I also mention that there is that which is called "practice" and that which is called "theory," and that while either may be had without the other, yet I think no man can justly style himself a gas engineer without being familiar with both theory and practice. When it comes to a choice I would prefer to have a man run the gas works that I had charge of who had merely the practical knowledge rather than one who had only a theoretical knowledge; for I should consider that he would make it more of a success. But if I could combine the two I would always do so. I do not think any of us will go to college again, but if we can only lead in the right direction those who are to come after us and take our places we shall feel that we have done something for the good of our profession.

On motion of Mr. Jenkins the report was received and the thanks of the Association voted to Mr. Gimper for his able and efficient work.

Mr. Geo. T. Thompson, of St. Louis, Mo., then read his paper, entitled

IMPRESSIONS OF BRITISH GAS WORKS.

To an American engineer one of the first contrasts between the gas works of Great Britain and those with which he is more familiar would, I think, be the ratio existing between the quantities of gas made in winter and in summer. Owing to the high latitude, this is usually in British works about as five to one. The next point noted would probably be the relation of annual sendout to the population of the district supplied. This may be roughly placed at two to three times the ratio in England than is the case in America.

A visit to nearly 40 works throughout Great Britain during the summer of 1889 showed the case to be the same there as here, that the largest works are not always the ones to show the most valuable or original ideas. The points that may be mentioned in a paper such as this may best for convenience be arranged in the order of the manufacturing apparatus.

In general, as transportation is not interrupted for any considerable period through the year, large coal stores are unnecessary, and suffi-

cient space for about four weeks' average supply is provided under the same roof as the retorts. Newcastle coal does not differ greatly from our Pittsburgh coal, and the Midland coals are somewhat similar to that which we get from Indiana, though perhaps yielding more tar and carrying less sulphur. Ten thousand feet per ton of 2,240 pounds is the standard yield of 15½-candle gas, enriched to 16 candles or upward by small percentages of cannel. Except where, as in Scotland, cannel is the sole or principal gas making material, the illuminating power of gas seldom exceeds 17 candles.

The buildings of the works appear more solidly constructed than do ours—a characteristic of English structures in general. Newbigging's condemnation of the practice of permitting waste gases from the bench furnaces to enter the air beneath the retort house roof has no application there, as chimneys are always provided. The latest constructed retort houses are ventilated by square or circular openings at the apex of the roof, several in the length of the house, in place of louvres. At Rochdale Road, Manchester, and the Portslade Works, Brighton, the chimneys pass through these ventilating shafts, which arrangement is said to be additionally effective in clearing the house of smoke.

In the two great London Companies, the "Chartered" and the South Metropolitan, two contrasting arrangements of retort houses are to be seen. In the Beckton works of the former the 12 houses are placed in two rows of six each, *end to end*; while at the Old Kent Road station of the second named Company the several houses are side by side, with coal stores between, thus saving to each house the cost of an entire side wall.

The retort house windows are set above the level of the benches and care taken to prevent ill effects to the heats by draughts—a matter which, though recognized as a partial necessity by American engineers, does not always affect their plans in construction. For works of medium or large size the ground-floor house has more advocates in England than in America. In the stage-floor houses the openings in front of the ranges are without doors or covers. The retort settings are built with firebrick cut to fit, instead of having blocks and tiles to lessen the number of joints in the oven, and thus make work easier in building. Except in small works the retorts used are "throughs;" and as these are credited with greater ease of scurving, while the singles work better to the hydraulic and give less chance of trouble with workmen, Mr. J. Ferguson Bell, Engineer to the Stafford Corporation, suggests that the throughs be blocked in the middle and worked as singles until requiring scurving, at which time the block can be knocked out and the retort be scurfed as a "through."

There are some strong advocates of brick retorts, and the benches at the new Greenwich station of the South Metropolitan Company are entirely set with these. Tiles with sides curved upwards are used for the bottoms, and the "D" built upon these with soap brick, with continuous joints. At Old Kent Road the mouthpieces were attached to brick retorts by having the entire bench front of cast iron lined with firebrick; but at Greenwich the mouthpieces were bolted to a cast iron shell, into which the end of the retort was built. I do not remember having seen a cylindrical retort in any American works, but in England they are frequently met with; while there, as here, ovals and "D's" are about equally in favor. Their "D's," however, have quite a sharp lower edge. The sizes of retorts are about the same as are used here, but the charges are rather heavier, and their duration usually six hours, and in some places even eight. The consumption of coke as fuel, except where a considerable proportion of cannel is carbonized, will not exceed an average of 30 per cent. of the make in direct firing, and is of course still less where regenerators are used. This lower figure than our own is possible by the use of the longer charges and somewhat lower heats, and to some extent by the greater average number of retorts per setting. An estimation of the fuel on the carbonization is made in some places, the result being also stated in a percentage; on this basis 18 per cent. fuel would indicate that 18 pounds of coke were consumed to carbonize 100 pounds of coal. Six thousand cubic feet of gas per day is accounted a fair yield per mouthpiece.

In the Scotch works mixtures of (say) two parts cannel coal and one part splint coal are made, which at 3-hour charges yield about 11,000 feet of 29-candle gas per ton. Even with regenerators 45 per cent. of the coke from this would be used as fuel, but its quality must be remembered.

In general the English gas stoker is better provided for at the works than his American brother. The retort house almost invariably has a "lobby," in which the workmen have lockers for their clothing, a wash room, and a larger room with a range or an open fireplace for heating coffee, cooking eggs or steak, etc. In addition to these there is often an "assembly room" for concerts or other entertainments, and a reading

room; and of these the men are very proud. In large works, such as Beckton, Nine Elms, Old Kent Road, Stepney and the principal provincial stations, the men have organizations of their own, varied in character, but all tending to good effects. At Leicester there is a thriving literary society and an efficient ambulance corps; at Beckton, a fire brigade; at Southall, a cricket team, having grounds placed at their disposal, and these and many other works have brass bands. The employees of the Brentford Company have also a mutual aid society, into which each man pays 6d. a week, drawing 15s. a week if sick or disabled, and with a fund for his family in case of death.

Sunday day labor is very generally avoided, though the men always hold themselves in readiness to work if required. But usually only enough men are kept to lunch the fires perhaps twice, the dampers being closed and the spent charges not withdrawn. In case a retort requires scurfing, the coke is drawn and in one operation with the through retorts the carbon is loosened and the standpipes cleared, without channel tiles.

The workmen are paid much less than they would receive here, but the prices of staple articles range considerably below our standard, on rents and clothing in particular. The 8 hour system has been adopted in a number of works during the past year. Several forms of power stokers are to be seen—West's, Foulis's and Ross's—but owing to the cheapness of labor their use is not attended by such a saving as with us.

From the hydraulic main the gas is led to the condensers by a so-called "foul main," which often entirely circles the retort house. The condensers are nearly all atmospheric, set in the open air; and the annular, battery and return tubes are popular forms. I heard of but two cases of trouble with naphthaline. In one of these the steam jet exhauster was the cause—and in the other the deposit was found at the holder inlet, where the connecting mains were carried down in the water, in a recess in the tank wall; so neither case was remarkable, and neither was difficult to handle. One engineer told me that he avoided naphthaline by keeping a uniform temperature of 67° Fahr. at the condenser outlet. But I think the lower heats carried in England and the freedom from sudden atmospheric changes are mainly responsible for the absence of this trouble.

The exhauster most in use is the Beale, very similar to our McKenzie. In many American works the gas is led to the exhauster before passing the condenser; but this practice is seldom seen in England, and moreover, in two of the works visited the exhausters were placed between scrubbers and purifying boxes. Some use of compound engines, even of the triple expansion type, is made for driving exhausters.

The pressure gauges used are very deep compared to those employed by us, and 48-inch gauges are by no means uncommon. The lack of holder counterbalances and the comparative cheapness of iron, and its consequently more extensive use in holders, enter as factors to necessitate this; and the purifier lutes and other seals are, of course, correspondingly deep. The simplest gauge seen consists of a 1-inch glass tube closed at bottom, with a loosely-fitting cap at top, through which passes a quarter-inch tube, with the gas connection at its upper end, and with the lower end notched. A scale behind or at the side completes the instrument. The jet photometer for detecting the production of gas of low illuminating power is usually placed by British engineers at the *exhauster* outlet, that the poor gas may be more quickly noted. The photometer generally stands on a case in which are two cast iron boxes a foot square, with faced cast covers, controlled by two four-way valves and filled with an oxide of iron tray each. The gas is thus sufficiently purified for the approximate test required.

The washers and scrubbers employed are almost as varied in patterns and methods of use as the works themselves. But the accepted practice at this stage of the purification seems to be the treatment of the foul gas by a washer charged with ammoniacal liquor, designed to combine a portion of the sulphureted hydrogen and carbonic acid impurities as sulphide and carbonate of ammonium, and to this extent to lighten the work of the dry purifiers. The last of the tar is also removed in this apparatus. Then follows a tower scrubber, into which clear water is admitted to complete the extraction of ammonia. The yield of ammoniacal liquor, of course, varies with the works, and as large an amount as 35 gallons of 10-oz. liquor per ton is reached.

The absence of extreme temperatures in English weather permits the purifiers to be set out of doors. But lest rain should interfere with the work of emptying or refilling open boxes, sheds usually cover the sets; though sometimes a portable roof is provided, or the box lid itself used. When either dimension of a box exceeds 20 feet the cover is usually lightly trussed.

The very general parliamentary or local restrictions regarding the amount of impurity—particularly sulphur—in the gas as delivered, and

to some extent as affecting the opening of foul boxes, have resulted in numerous systems being advanced to simplify or cheapen the process or to avoid the nuisance attending it. In this, valve systems have largely aided; and where center-seals are in use a catch-box is provided to prevent the output of foul gas, which might pass through the seal when a change is made. In the materials for purification, a large amount of oxide of iron and Irish bog ore is used, not always revived *in situ* by any means; indeed, I received the impression that in proportion to the number of works using oxide there is more reviving *in situ* in the United States than in England. But air is very considerably used in lime purification, and was the forerunner of Valon's oxygen process. With lime the effect of the air introduced seems practically the same as with oxide—sulphur is partly fixed in the material, and the frequency of purifier changes is much diminished, while the spent lime is largely deprived of its obnoxious smell. In most of the works iron and lime are used in conjunction.

Like the purifiers, the station meters can be set out of doors, and in some cases the housed and the unprotected meters may both be seen in the same works, notably at Beckton. Generally, though, the meters are within buildings, as with us; but the form of the instrument, except in the smaller sizes, is the square-cased. The unprotected meters at the South Metropolitan's Old Kent Road and Greenwich stations are the invention of Mr. Geo. Livesey. In these, the lower three-quarters of the case is of concrete, set into the ground, while the part above ground is cased in zinc and covered with tongued-and-grooved boarding, with a non-conducting packing between boards and metal. The drum is of the usual form, and the dials are protected in a padlocked case at one end.

Many of the meters have for the water line indicator a differential pressure gauge, which also shows the levels of water within and without the drum. In some of the French meters brass discs, bearing the ten numerals on their edges, are substituted for the usual dials; these edges face outwards, and the discs turn as do the registers on some of our street cars, exhibiting but one figure of each disc, so that the reading can be taken at a glance without error.

The most sweeping change in holder construction is that seen at the Rotherhithe station in London, in dispensing with upper guide framing. The structure on which this has been tried was a double-lift of one million feet capacity, working in an annular iron tank which stands about three-eighths above ground. On the addition of the third lift the spar columns were each tied to the tank by two additional angle irons, the channel-iron tank curb was reinforced by curved plates placed horizontally and riveted to the channel-irons and to an additional angle iron within, and a cement filling was added between the back of the guide rails and the inner face of the columns. The second and third lifts carry both radial and tangential rollers, but the topmost section has only the radials. The channel guides on the columns are carried about 2 feet above the caps, and then curved outward and braced to the entablatures. The sections are each about 29 feet deep, and the tank stands about 12 feet out of the ground, so that the columns are 70 feet high and the unsupported lift rises 25 feet above this, and in this position withstood several storms in the winter of 1888-9. Nearby another holder in a cast iron tank, 80 feet in diameter, was also being rebuilt, to have five lifts 23 feet in height each (exclusive of cupping), and columns to the top of the third lift, thus leaving 46 feet in 115 clear of the framing. It is no doubt the case that many holders are in use whose framing, owing to having been built by "rule of thumb," or with more than ample margin for safety, is considerably in excess of the needs of the accompanying lifts, and in such cases this system might profitably be applied if the strength of the existing framing were known. But in new constructions it seems to be a question of supplying strength in heavier bottom curbs, cups, guides, and rollers, and more firmly anchored framing, if absent in the upper structure. This problem, however, is receiving much attention, and between this solution and that offered by Mr. Gadd and others the future of holder construction may show many changes.

The English holders in general carry no counterweights. Those above medium size are mostly fitted with both radial and tangential rollers, and in France are a number of holders with only tangentials. While most of the structures erected lately show the use of channel guides instead of channel rollers, those less recently built have only single-flanged guidewheels, set alternately right and left. The side sheeting is nearly always made with the vertical joint continuous as well as horizontal. Piggott cups are extensively used. Dry wells for the inlet and outlet pipes are more common than with us, though they are not now built for tanks of large size; and in France the articulated pipes are much in favor.

Among the new points now introduced are two brought forward by

S. Cutler & Sons, which deserve special notice. The first is the placing of the web of the lattice cross girders horizontally instead of vertically between the columns. The second is the arrangement of the crown plating as shown in the sketch. The plates are all cut and punched

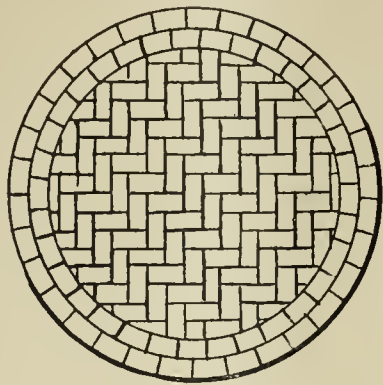

alike, two widths in length at the joints, all double riveted; the center plate overlaps on all sides and the others have a uniform fall downwards and outwards until near the curb a strong construction of concentric rings of steel sheeting meets the rectangular plates. This system, by lessening the unbroken joints, dispenses with the necessity for heavy center plating and graded concentric sheeting, except at the curb, thus simplifying and cheapening the construction as well as strengthening it.

At the works of the Crystal Palace District Company the ashes, breeze, broken retorts, etc., are being used with tar to form a new holder tank. The blocks are being made on the spot where they are to be used after the excavation is done. This tank wall is intended to brace the clay only, as the latter is of good quality and firm. Tank framing is superseding crown trussing, and several tank crown supports of iron are in use.

The main pipes about the works are generally made with the turned and bored joint, and this is also considerably used for the street mains. The street pressures carried are about $\frac{1}{10}$ minimum and $\frac{2}{5}$ maximum, for in localities at all hilly, district governors are used. The leakage averages but little above 6 per cent. of the make. A large proportion of the consumers' meters are of the wet description.

With regard to residuals, the coke brings about 7d. per cwt. (or 4½ cents per bushel of 36 lbs.) at the works in London, and in the provinces the price is yet lower. The enormous production of coke by gas makers (no water gas being made) keeps the price down to even a greater relative extent than is done in this country by our Pennsylvania ovens. The manufacture of sulphate of ammonia by gas companies and corporations is much more extensively carried on than here, and in some places the tar and sulphur are also worked up.

The price of gas averages about as charged in the metropolis, 2s. 6d. per 1,000, but in one place it is sold for 1s. 8d. These lower figures than our own are possible by the less cost of labor, coal, lime, etc., by the proportionately greater amount sold with its reduction of fixed charges, by the greater return from residuals, by the lesser candle power supplied, and by the fact that the laws do not permit—much less invite—competition, but they rather protect the companies in a rigidly restricted monopoly.

In concluding I cannot speak too warmly of the hearty welcome accorded by every gas engineer whom I visited. Many of them entertained me at their homes, and I found everywhere a cordiality, a willingness to afford all desired information, and an interest in and respect for American engineering that produced an impression as lasting as it was agreeable.

Discussion.

Mr. G. T. Thompson—In connection with the paper I would like to call the attention of members to a number of views which I took with a Kodak, that are on exhibition at the back of the hall. Those in the two lower corners represent the two forms of unprotected meters. In the righthand corner is the form in use at Beckton, and in the lefthand corner that in use by the South Metropolitan Company. The upper views are of French gas works.

The President—You have heard a very interesting paper from Mr. Thompson, and I know he will be glad to answer questions. The paper is before you, and I trust that it will be thoroughly discussed.

Mr. Dunbar—I visited, last fall, several gas works in Great Britain, and Mr. Thompson has given a very correct idea of the existing state of affairs so far as my limited observations permitted me to judge. One thing, however, he did not mention, and that is the universality of gas lighting. It is only in exceptional cases where the arc light is used. In Liverpool at night, I was unable to count over half a dozen lights on

the docks—the latter extend out into the harbor—and it is with considerable difficulty that gas can be brought to them, yet such is the almost universal use of gas that they had it out on the docks instead of the electric light. They were burning gas there, where one would naturally think that electric lights would most be in demand. In London the street lighting is all done with gas. I think I did not see to exceed half a dozen arc lights there, although at the hotels one has the choice of incandescent light or gas. One reason for the great amount of gas being used is the cheapness with which it is furnished. I do not know why they should furnish gas there so much cheaper than we do. Of course they obtain their labor cheaper, yet, as Mr. Thompson has suggested, the capital invested in the plants is much greater than in ours, for the reason that in the winter season they have to supply about five times the amount of gas that they do in summer. At any rate the amount of gas they sell will permit them to furnish it at a cheaper rate. That accounts for the absence of the electric light. To my mind a gas company which is not disposed to enter the electric lighting field can only successfully compete with the electric light by furnishing cheap gas. The streets of London are as well lighted as any city that I know of which is lighted with the electric light, and perhaps better. The lamp posts are only about 50 feet apart, and in the center of the streets they also have lamp posts, so that the light is very thoroughly diffused, and at no place is there the strong contrast that you find in towns lighted with electricity. Water gas has not yet made any inroad there. In the suburbs of Glasgow a plant was in process of erection, but I do not know what success it will have. Their construction of works is similar to ours with the exception that a great deal of the apparatus is out-of-doors. My experience is also that while their stokers do nominally much more work than our stokers, yet the peculiar construction of the retort houses is such as to make that work easier. A large number of stoves are used there for cooking purposes, and everything is kept in good order.

Mr. Lansden—I would like to ask Mr. Thompson whether the price paid the stokers is less than that we pay; also the price of coal as compared with the price paid here, the prices paid stokers per day, and the number of pounds a stoker ordinarily handles as compared with what they do here, in order that we may compare what they do with our ideas of cheap gas.

Mr. G. T. Thompson—I have some notes here which, although not figured in the form of Mr. Lansden's questions, may enable him to get at the idea for himself. Of course the price of coal varies very greatly with the locality. In the London companies it is close to twelve shillings per ton; in the provinces rather less. The amount of work which is done by the men in the retort house is rather difficult to state in such a way as to compare with our American works, because while here a stoker generally attends to some extent to the coke, and to the firing of the benches, there each man to a great extent has a special branch of the work only. For instance there there will be stokers, firemen, coke-wheelers, coal trimmers, barrow-men, lid-men and men who do nothing but attend to the stand-pipes. In the retort house the wages run about as follows: Fireman, caring for 8 direct fires, or 10 regenerators, (5s. 4d.), one scoop-driver or "tee-man" (at 5s. 6d.), and two "second-stokers" or "lifters," (at 5s. 3d.), form a gang for drawing and charging, working 90 mouthpieces per watch of 12 hours, at 6 hour charges. Sometimes to each five or six gangs there is provided another who helps whenever needed—filling scoops, helping draw, luting lids, etc. He is paid about 5 shillings, and is called the trimmer, barrow-man, etc. In the Dublin Works I was shown about by one of the retort foreman (it was in the evening, and the Superintendent was absent) and in showing me the arrangement of gangs he explained the manner in which the four or five gangs were formed, and then showed me the extra man. I asked him what he called him, and he replied: "He do be the 'lob lolly mon'"—quite an expressive term. The amount of coal charged would vary with the size of the retorts,—350 cwt. to the largest size of retorts, an average of 3 cwt. to the smaller. They have some very large retorts—22 feet long. Scoop charging is almost universal; and the men receive about 5s. 4d.

Mr. Odiorne—Do they use self sealing lids there generally?

Mr. G. T. Thompson—Yes; very generally.

Mr. Odiorne—Do they give good satisfaction?

Mr. Thompson—Excellent satisfaction.

Mr. Watts—I think Mr. Lansden's question could be better answered by giving the cost of labor per thousand cubic feet of gas made in the works that are working by hand, and without mechanical stokers.

Mr. Taber—I made some average estimates from the returns of the English companies sent me the other day, and found that the cost of coal there on the average was \$2.37, and the cost of labor, repairs and

other items which made up their cost of gas in the holder amounted to 18 cents per thousand feet. This may have some bearing on the question that Mr. Lansden asked.

Mr. Watts—Will you repeat those figures again? Where was that?

Mr. Taber—That was the average of 24 gas companies in England of which I had the returns. The general average for coal was \$2.37 per ton, and the cost of all the other expenses necessary to what we would call gas in the holder, including the cost of purification, labor and repairs, was 18 cents per thousand feet.

Mr. G. T. Thompson—Is that for the cost of retort house labor only?

Mr. Taber—For retort house labor, repairs, purification and everything.

Mr. Watts—Does that take into consideration the by-products?

Mr. Taber—No; the by-products brought it down eleven cents per thousand on the average to a ton of 2,240 pounds.

Mr. Lansden—The 18 cents included the cost of labor, repairs, purification and everything?

Mr. Taber—Yes; not including coal, of course; and 11 cents would be deducted from this for the residuals.

Mr. Egner—In connection with this one would naturally ask why it is that they can sell gas so much cheaper in England than we can in America and that leads me back to what we were talking about yesterday—the legislation which we have here. Our works are usually capitalized at a much higher rate per thousand feet of gas made than they are in England; and the consequence of the unreliable, often adverse legislation is, that they try to make all the money they can while they are able to, because to-morrow perhaps the town or city Council may pass a law, without any apparent reason, requiring them to sell gas at 25 cents or any other arbitrary figure per thousand, and the gas company must then go to law and spend a lot of money to save themselves, or else lose their business. This is discouraging to those who desire to sell cheap gas, and is an experience unknown *anywhere* but in the United States; and is beginning to become unpopular there in enlightened communities, I am happy to say.

Mr. J. B. Howard—I notice that at the conclusion of Mr. Thompson's paper he says: "I cannot speak too warmly of the hearty welcome accorded by every gas engineer whom I visited. Many of them entertained me at their homes." Can it be wondered that they would take to their homes a typical American youth—especially if they had marriageable daughters? (Laughter.)

Mr. Watts—I would like to ask Mr. Thompson about what percentage of regenerative furnaces were used in England.

Mr. G. T. Thompson—I think that is a matter which I mentioned in my paper. I say that, "For works of medium or large size the ground-floor house has more advocates in England than in America." That statement would naturally carry with it the impression that the regenerative furnaces as used in stage-floor houses are less in use there than here for works of medium size.

Mr. Watts—Are there any regenerative furnaces at the Beckton station?

Mr. G. T. Thompson—Yes; they are all regenerative.

On motion of Mr. Ambrose the thanks of the Association were voted to Mr. Thompson.

(To be continued.)

The "Express Company" System of Collecting Gas Accounts.

Treasurers and managers of gas companies have watched with increasing interest the arrangement now in vogue in several of the largest cities—notably Chicago, St. Louis, Buffalo and Boston—by which the American Express Company, which has a very large number of branch or sub-agencies for sale of its money orders, generally in drug stores or stores of similar character that are open through the day and evening, has arranged with the local gas companies to receive payment of their bills at all such agencies. The bills so paid are taken up each day by clerks from the main office of the express company, properly scheduled, and the schedules, with the cash or a check to balance same, is handed to the gas company at an early hour on the day following that on which the bills were paid. This system relieves the gas offices of all the rush on days when bills are due, decreases the liability to errors by clerks in receiving a great number of payments, and turns a very large number of small payments over to the gas company in such shape that they can be credited upon the books with the greatest facility.

The arrangement was originally contemplated for the convenience of people in large places who, living at some distance from the gas office, it was supposed would be willing to pay a 5 cent fee for a money order at the nearest drug store rather than to spend time, and perhaps 10 cents in car fare, to go to the gas company's office.

The large number of payments that are being made in this way in the cities mentioned goes to show that a large number of people appreciate the advantages offered, and we believe that, even in the smallest cities, gas companies will find it to their profit and convenience to make a similar arrangement with the express company, even if they pay the fees themselves. A thousand bills can be collected in this way at an expense of only \$50, and with the unquestionable responsibility of the express company, and consequent elimination of all possibility of losses by dishonest collectors and of the expense for salaries of collectors, it would seem to be a step in the direction of greater economy in the transaction of the business, which, in these times of competition, is well worth consideration.

We are told that the money order department of the express company will furnish complete information on the subject, on request.

A Brin's Process Company for New York.

The Brin oxygen process for the purification of coal gas is taking fairly rapid strides in England, as shown in the fact that the Ramsgate, Shrewsbury and Rochdale Gas Corporations have erected works for the practical carrying on of the process in their gas plants. The Montreal (Canada) Gas Company has entered into a contract with the Brin Oxygen Company, of London, for the erection of an oxygen producer to treat the whole of the make at one of their works.

What will interest American gas engineers most, however, will likely be found in the statement that a company has been formed in New York, and the capital subscribed, for the erection of a works in this city. Mr. James, the Engineer in charge of the Paris (France) section of the Continental Oxygen Company, has arrived to superintend the construction, and it is intended that the works will be completed in September. Gas engineers will then have an opportunity of witnessing the separation of oxygen from the atmosphere on a large scale, and if anything like the results obtained on the other side are borne out, we may look forward to a rapid development of this interesting process in the United States and Canada.

How to Manage Steam Engines.

By B. TAYLOR.

It is a rather difficult matter to write about the management and repairing of engines, as nearly all the repairs are what should be a machinist's job, as nearly all would require machine work to properly complete it, therefore it cannot be classed as a part of an engineer's business.

As regards the management of steam engines, it will be necessary to begin at the foundation, and give a minute description of the manner of setting up and adjusting work, which every engineer should understand in order that he may know what his engine needs when not doing its work properly. Every foundation for an engine requires the skill of a stone or brick mason to build, and when that is properly done then the engineer's duties begin, the first thing being to place the frame or engine bed upon the foundation, seeing that it is banded up and firmly bolted in its proper position. The next thing in order is to place the shaft in its bearings, seeing that it is on a proper level and fits its bearings properly, to run easy and smooth. Then place the fly-wheel in position upon the shaft, taking care that it runs true (as it should be properly fitted when made), placing it equal distance between the shaft bearings, so that the weight will be alike on each. Next in order is the placing of the cylinder on the bed in its proper position; there should be no mistake about this, as there should be what are termed steady pins to hold it in its place.

To prove that the shaft and cylinder are properly placed, attach to the outer end of cylinder a small piece of board long enough to reach across its end and fasten with one of the bolts which hold the head on. Attach to this piece a fine strong cord or wire that will not break on being drawn tight; fasten on the farther end of the bed another piece of board, leaving enough to stand up as high as the center of cylinder, attach the other end of the cord to the latter piece, bringing it exactly to the center of cylinder, which can be done by calipers. Turn the fly-wheel over, bring the wrist-pin to the line, and be particular that it is exactly in the center of the bearing on the pin; then reverse the fly-wheel, bring it to the line on the other center. If the line is on the center of cylinder, also on the center of wrist-pin when turned on both centers, then your engine is in line; but if not then the cylinder must be out of line, or else the shaft is not square with the cylinder, in which case it must be brought to a perfect line, either by moving the cylinder or pillow block at the outer end of shaft. When these points are in a perfect line, put in

the piston and attach the connecting rod to the cross head, being sure that the cross-head comes in a perfect line with the center of cylinder.

When this is accomplished, all is ready for connecting the smaller parts, such as cut-off, rod valve, etc. This brings us to an important part of the work, viz., the setting of the valve, of whatever kind it may be. I find this the most simple way to adjust in a slide valve engine. Turn the fly wheel to its farthest point, or, in other words, to its center point, which will bring the piston head to one end of cylinder; now set the valve so as to cover the port, leaving not more than one forty-fourth of an inch for the introduction of steam, when the crank is on its center, and see that the valve stands in the same position; if not, it must be adjusted by the length of connecting cut off rod, until the valve stands in the same position at each central point. When this is done see that the exhaust port is clear, to relieve the cylinder of the steam at the proper time. I have seen engines set up with the valve of a length not to admit of a free exhaust, which caused the engine to work heavy.

Another important point in the arrangement of an engine is the steam feed and exhaust pipes. The rule generally adopted is, to have the exhaust pipe one-half inch larger than the feed pipe, but I find by experience that the exhaust should be one inch larger, which will cause the machine to run much freer, causing less strain than when a smaller pipe is used.

Another important point is the setting of the piston packing rings; these should be set very carefully, taking great care that the piston head is exactly in the center of the cylinder, using a pair of calipers in adjusting it.

As regards care and management of an engine, after being put in order according to the above-named points, but little work is required, but it must be constantly watched and kept well lubricated in all its parts, the cylinder receiving special care. It should have a lubricator attached to the feed pipe just before it enters the cylinder, emitting two or three drops per minute, according to the load the machine is carrying, and great care must be taken with the packing rings, to keep them just tight enough to prevent any leakage of steam, and not tight enough to cause any great friction.

I have found that one good qualification in an engineer is to know enough to let his machine alone when it is working well, and to know when it is doing well. I have known men in charge of machines to be constantly at work at them, and often getting them out of order instead of benefiting them.

Great care should be taken to keep all the bearings just tight enough to run easy without any slack motion, which causes them to thump or pound at each revolution.

In setting up the keys I find it best to use a soft metal hammer, which will not bruise the end of the key. In using, hit it one blow on the point, which will give it a little back motion, just to give the bearings a free working motion.

It is the custom of many engineers to oil the cylinder three or four times per day with about one gill of oil, but this is not the proper way. A cylinder needs oil, the same as any other bearing, in very small quantities, and often.

Another important matter is in starting the machine. All drips should be opened and the water drained out, by letting a little steam in to warm up the cylinder before it is started, and then slow for one minute, giving it time to work off all water which has settled in it, getting it well warmed up before running at full speed.

The great point in management is to keep close watch and to know when the machine is not running right; then, if wrong, learning just what the trouble is before any changes are made, as the machine may be injured by not doing the right thing. An engineer should be a good machinist, as well as a careful man, possessing good judgment, never doing repairs or making changes until he knows what is necessary to be done.

If the above rules are strictly observed very little repairs will be needed, except in case of breaks, and as to directions about repairs, no mechanic can tell just what to do until he sees just what the break is and determines its cause. Any other plan for repairs would be much like "ideal farming;" practical knowledge is the best.

BERTHA LININGER, of Detroit, Mich., has brought suit for \$50,000 damages against the Michigan Gas Company, of that city. In her complaint she alleges that, while driving over the Boulevard, close to Fort street, on the evening of February 5th, last, the buggy was overturned because of an excavation made by defendant and allowed to remain in an unguarded state. In consequence of the upset she sustained severe personal injuries; hence the suit.

ITEMS OF INTEREST FROM VARIOUS LOCALITIES.

A NEW gas scheme has been introduced in the St. Louis City Councils, the putative father of the same being Mr. Sloan. The projectors ask for a franchise for the construction of a complete gas works, who in turn bind themselves to furnish illuminating gas to ordinary consumers, for a period of 50 years, at the rate of 90 cents per thousand for lighting uses, and at 40 cents per thousand for fuel purposes. The city has the right to purchase the works, under an option, 10 years after their completion, and every 10 years thereafter until the end of the franchise term. The value of the plant, if the city wishes to buy it, is to be returned by three appraisers, one to be named by the Company, one by the City Assembly, and one by the Circuit Court bench. For the franchise the projectors propose to give the city all the net profits of the works over and above 8 per cent. on the net earnings, and when the proprietors have received \$50,000 per year out of the 8 per cent. they agree to release to the city one-half of the earnings in excess of that amount. Our informant adds that there is ample capital behind the project, and that Mr. R. D. Walsh, son-in-law of Mr. Socrates Newman, who was prominent in the affairs of the old St. Louis Gas Company, is one of the incorporators.

At the annual meeting of the Consumers Gas Company, Reading, Pa., the following officers were chosen: President, Henry Baumgardner, Lancaster, Pa.; Secretary, John H. Keppelman; Treasurer, William Elkins, Phila., Pa.; Manager, Martin Maloney, Phila., Pa.. Solicitor, R. L. Jones; Superintendent, John H. Keppelman. Directors, Henry Baumgardner, Martin Maloney, Wm. L. Elkins, Jr., and R. L. Jones. The annual reports disclosed a satisfactory year's business. On the adjournment the Directors inspected the elegant new plant (now almost finished) underway at the South Fifth street station, after which they repaired to the Mansion House for dinner.

THE following new schedule of rates has been formally promulgated by Mr. F. M. Acton, Secretary of the Salem (N. J.) Gas Light Company, discounts to be available when bills are paid within 10 days from time of presentation:

Quarterly Consumption.	Gross.	Net per M.
2,000 cu. ft. and under.....	\$2.00	\$1.80
2,000 to 5,000 cu. ft.....	1.80	1.62
5,000 to 7,500 ".....	1.70	1.53
7,500 to 10,000 ".....	1.60	1.44
10,000 to 20,000 ".....	1.60	1.36
Over 20,000 ".....	1.60	Special.

The quality of the gas sold at Salem averages 18.70-candle power, and is remarkably free from impurity. Although the figures are eloquently expressive of the Company's liberality, we cannot forbear the remark that the Salem gas men are to be congratulated on the fact that, relatively, their gas prices are the cheapest in the State of New Jersey.

MR. JOHN E. JEFFRIES, a well known and popular resident of Birmingham, Ala., died suddenly in that city on the night of the 2d inst. He had been a resident of Birmingham for 19 years, and had been prominently identified with the local gas company.

ON May 31st the Richmond (Ky.) Water Works, Electric Light and Gas Companies were consolidated, under the title of the Richmond Water and Light Company, the capital stock being placed at \$200,000. The officers are: President, A. E. Boardman, Macon, Ga.; Treasurer, Edward H. Yorke, Portland, Me.; Secretary, Chas. S. Powell, Richmond, Ky.; Directors, A. E. Boardman, J. A. Jullian, Theo. C. Woodbury, W. B. Miller and Chas. S. Powell. The Company has acquired location for source and reservoir of water works branch on a plot (160 acres) 2½ miles east of city, and a new location for gas works on a plot (1½ acres) in lower part of city, on which a complete gas plant will be constructed. The elevated water tank and tower structures contracts have been awarded, and the work of construction will be pushed. Public lighting and water contracts to the value of \$6,000 per annum have been ratified, and the Company has filed a bond in \$10,000 to faithfully carry out its agreements.

MR. THOMAS EVANS, the clever and capable Secretary of the Hartford (Conn.) City Gas Light Company, accompanied by his wife and son, sailed for Europe, on the 4th inst., per steamer City of Chester, to enjoy a well-earned vacation of two months.

WE understand that during a recent violent storm of lightning and thunder in South Dakota the electric current sought "earth" by way of the gasholder of the Sioux Falls Gas Company. Several of the sheets

were twisted sufficiently to permit the stored gas to escape. The holder held at the time about 60,000 cubic feet of gas, all of which was lost.

THE Board of Directors of the Kansas City (Mo.) Gas Light and Coke Company organized in the re-election of the following officers: President, M. J. Payne; Secretary, Walter Woolcott; Superintendent, Geo. S. Clarke. An efficient staff, surely.

PRESIDENT JOSEPH BARSTOW, of the Atlantic City (N. J.) Gas Company, is very much elated over the economy that has resulted in the electric lighting department of the Company's business as a consequence of the partial displacement of steam power by gas power in the dynamo room. A 50-horse power Otto engine has been installed in the works on Michigan avenue, and its operation is pretty close to perfection. The Company, which has the contract for the public electric lighting of the city, operates the Thomson-Houston system of full arcs and has over 100 lamps in circuit, with the probability that that number will be doubled by July 15th when the "board walk" will creak with the weight of Philadelphians of all grades. By the way, the rate charged for arc lighting on public account is very reasonable—25 cents per lamp per night.

OWING do the courtesy of Manager H. M. Stocum, of the Tonawanda, N. Y., Gas Light Company, we are enabled to print the following revised schedule of gas rates that has ruled there since the first inst.:

Monthly Consumption.	Net, per 1,000 cu. ft.
200 cubic feet and under.....	\$1.50
300 " to 900 cubic feet.....	1.45
1,000 " " 2,900 "	1.40
3,000 " " 6,900 "	1.35
7,000 " " 11,900 "	1.30
12,000 " and over.....	1.25

The only condition is prompt payment—that is, within 10 days from date of bills. In his letter to us on the subject Manager Stocum says: "The Directors of this Company believe that the success of all gas companies depends on the institution of minimum prices, because gas as an illuminator is thus placed within the reach of all. We have contracts for street lighting for ensuing year at the rate of \$18 per lamp per annum, all-night table; the authorities assuming the expense of lighting, extinguishing and repairing. Our ordinary consumers are giving us good and substantial patronage; and our send-out shows a good increase." The Tonawanda Company's proprietors are evidently shrewd business men, and their Manager fills the bill in every sense.

AT the annual meeting of the Camden (N. J.) Gas Light Company the following result was reached in the election: President, B. F. Archer; Secretary and Treasurer, Charles Watson; Directors, B. F. Archer, Jno. McIlhenny, Samuel C. Cooper, Charles Watson and Richard F. Smith. The Company enjoyed a very prosperous year.

AT the meeting of the stockholders of the Hollidaysburg (Pa.) Gas Company, held on the 2d inst., at the Drexel building, Philadelphia, the following officers were chosen: President and General Manager, Henry W. Brooks; Secretary and Treasurer, Ivan Prowattain. Managers, George N. Torrence, William Barritt, Jr. and Ernest Prowattain. Having remarked that the Company ought not to suffer from lack of "Managers," it is next in order to say that when the Brooks process was arranged for at Hollidaysburg the chief claim made in its favor was that the residents were going to have much cheaper gas. The fact is, however, that the Hollidaysburg rate is likely to be put at \$1.75 per 1,000, whereas in the not far-away district of Altoona gas is sold at \$1.20, and even little Tyrone bobs up serenely at the \$1.25 rate. To be sure, Altoona is quite a large and bustling place, and Manager Cole is kept pretty busy in keeping pace with the demand; but the disparity between Hollidaysburg and Tyrone as gas towns is not worth mentioning, save that the Brooks process is not in vogue in the latter place; nor will it ever be, if Manager Dieffenbaugh has the verdict to prepare. The correspondent who forwards us the above hints is authority for the statement that, "the Brooks Process Company, in proposing to charge \$1.75 per 1,000 for gas, will be no improvement over the old plant and practices, and hence is of no use to Hollidaysburg."

THE proprietors of the Cohoes (N. Y.) Gas Light Company have cut their selling rate to \$2 per 1,000. Former price, \$2.50.

GOVERNOR HILL, in giving his sanction to the Jones bill for regulating the gas rate in New York city at \$1.25 per 1,000, in Brooklyn at \$1.50, and in cities holding between 100,000 and 500,000 population at \$2, filed the following explanation: "I have heretofore recommended

the creation of a State Gas Commission (which should also include in its jurisdiction all telephone and electric light companies), to be invested with limited powers somewhat similar to those possessed by the Railroad Commission over railroads. I have during the past few years approved several bills regulating the price of gas in various cities, but more than once I have intimated my reluctance to approve any more such bills until such Commission should be created, by which the propriety of such measures might be carefully investigated, and legislative action might be based upon the recommendations of such Commission. The regulation of the price of gas, as well as the charges for electric lights and telephones in different cities by legislative power is liable to abuse, and should only be exercised after proper investigation by a competent Board. Corruption, prejudice, fickleness, unfairness or favoritism is too apt to characterize or accompany legislation upon such an important subject, particularly in the absence of a semi-judicial investigation of the conditions and circumstances which should naturally affect its determinations. I am still impressed with the desirability of such a Commission as I have suggested, and trust that another Legislature may in its wisdom pass a carefully guarded measure carrying out this recommendation, to the end that the possibility of hasty, arbitrary or ill-considered legislation upon this subject may be avoided. The present bill, however, as I understand it, made very slight changes in existing prices, and in the present statute applicable to the various cities of the State; and as such changes seem to be in the right direction and reasonable, it is believed, upon the whole, that the public interest will be best subserved by the approval of the measure."

THE suit of the United Gas Improvement Company against the Milwaukee Gas Light Company—in restraint of the use of certain apparatus in gas manufacture by the latter, the right for the sale of which is exclusively claimed by plaintiff—was called up in the local Circuit Court (June 6th) on a motion to fix a date for the hearing of a motion for an injunction. Mr. J. R. Bennett, of New York, who represented the Improvement Company, asked that the date be fixed for a day in July, but Mr. Miller, of counsel for defendant, asked that it be postponed until September or October. Mr. Bennett then asked for a continuance bond, whereupon Judge Gresham wanted to know if Mr. Bennett doubted the solvency of the defendant. Mr. Bennett said that he had not made inquiry as to defendant's solvency, which reply created a ripple of suppressed merriment in the court room. Judge Gresham thereupon delivered an extempore opinion as to his belief in defendant's reliability, and the case went over to the fall term. Plaintiff originally asked for a hearing in April, but defendant secured a postponement until the current month. The latter was ready to go on at the present time, but plaintiff desired a postponement until July. Defendant would not agree to so short a lapse, but would accept a transfer to the fall term, with the result stated above.

AT a special meeting of the Birmingham (Conn.) Borough it was voted to abate the taxes of that portion of the plant of the Derby Gas Company, to be located on the east side of the Housatonic river, in the Borough of Birmingham, for a term of 5 years. The Company asked this concession with a view to transferring its electric plant from Shelton.

JUDGE LEARNED has made an order giving Attorney-General Tabor leave to bring action to dissolve the corporation known as the West Troy (N. Y.) Gas Light Company and to dissolve its affairs. The order was issued on a petition by the Attorney-General, in behalf of Robert Bryce, a stockholder of the Company.

AT a recent meeting of the Gas Committee of Philadelphia City Councils the petition of the Weil Enriching Company for an investigation of its process, with a view to the adoption of the same in the plants of the municipal gas works, was referred to the sub-committee on extensions and works. Mr. Meehan's resolution to charge property owners with frontage for gas mains was ordered reported back, with the request to refer the same to the Municipal Government Committee to prepare a bill.

THE gas war at Aurora, Ills., is at an end, the competing companies having agreed to consolidate. The gas rate will be advanced to \$1.50 per 1,000. During the contest the price had been cut to less than \$1. Thus ends the first Peter English process strike.

THE Covington (Ky.) Gas Light Company has been worsted in its contest in the Circuit Court with the city over an attempt by the latter to oblige it to pay taxes on an assessment of its franchise at the ratio of \$75,000. Hitherto the Company paid taxes only on its real estate, and Assessor Whitney brought the case into court. Mr. Fisher, for the

Company, argued that no corporation franchise had been taxed in Covington, and further pleaded that in any event the Gas Company should not be so taxed, no matter what was the ruling practice in other cases, as the Company's service to the city at a cheaper rate than its service to ordinary patrons was in the nature of a direct payment on account of the franchise it enjoyed. Mr. Byrnes, on behalf of the city, argued that the franchise was property pure and simple, and as such was subject to taxation for whatever value it possessed, the same as any other species of property, and that it held no qualifications that should exempt it from tax burdens on account of alleged public service. Judge Arthur decided in favor of the city. The case will go to the Court of Appeals.

GEO. W. LITTLE, of 4925 Lake Avenue, Chicago, has brought suit against the Hyde Park Gas Company for \$5,000 damages, the case to be called in the Circuit Court. He alleges trespass, and asserts that until recently defendant delivered its bills by messenger. Lately, however, the bills have been sent by mail, and if the Company does not receive payment by the 12th of the month the "big burly man who turns off the gas" performs his duty. About May 15th the "big burly man" visited Little's house and shut off the gas, much to the discomfiture of Mrs. Little, who averred that the bill had been paid. Little asserts that the "big burly," etc., used "unparliamentary language" in replying to Mrs. Little; but the gas was cut off. Little thinks the "big burly" should have cut off the gas at the sidewalk and not entered his house; nor should he have used the unparliamentary, etc. Hence Little's claim for \$5,000. It is not the first time that Little's gas has been cut off for non-payment, which leads us to believe that he is a bit of a chronic growler, who also suffers badly from impecuniosity.

THE franchise for a gas company at Rapid City, So. Dak., has at last been granted. The grantee is a Chicago syndicate, headed by the Hon. W. T. Coade. The projectors say they will invest \$75,000, and begin construction work on or before July 10th.

AT a meeting of the Akron (O.) Heat, Light and Power Company no change in the executive management was made. Arrangements are said to have been made for an extension of the main system.

ELSWHERE we reprint the Governor's action in respect to signing the new gas rate laws for this State. As usual, the smart gentlemen up in Albany have about "over-done" themselves, in that the only essential change effected by the bill will be to keep the maximum gas rate in Brooklyn at \$1.50 per 1,000, whereas under the effect of an older special law, putting the price of gas "in cities having a population of 800,000 or over" at \$1.25 per 1,000, Brooklyn companies would undoubtedly have had to come to the \$1.25 rate when the present census enumerators finished their work; for there can be no doubt about it that Brooklyn's population is now in excess of the stipulated 800,000. Some assert that much of the latest Albany gas law is traceable to "the fine Italian hand" of Henry H. Rogers, who is not unknown to those who have incurred the displeasure of the Standard Oil Company. In any event, the Brooklynite who is responsible for the present measure is to be congratulated on his *finesse*. Prof. Collin, the "I-am-a-Democrat" man's legal adviser, is a bit uneasy over the situation, and to show how ragged are his waking hours we herewith republish some remarks uttered by the Professor when his woe was evidently deep: "Several newspapers seem to have misapprehended the effect of this bill upon the price of gas in Brooklyn. If the new law affects Brooklyn at all it makes a reduction of 10 cents per thousand cubic feet upon the maximum price that may be charged for gas in that city. Before signing the bill the Governor referred it to me with instructions to examine and report upon this precise point, and I gave him the result of my investigations, substantially as follows: By the general law of 1886, Chapter 922, the maximum price of gas in cities having a population of 800,000 or over was fixed at \$1.25 per 1,000 cubic feet. By a later special law relating to Brooklyn only the maximum price of gas in that city was fixed at \$1.60 per 1,000 cubic feet. The later special law, of course, controlled the previous general law, so that I advised the Governor that if he did not sign the bill before him the maximum price of gas in Brooklyn would remain \$1.60 per 1,000, even if Brooklyn should show a population of more than 800,000 by the new census. The bill signed by the Governor yesterday fixes the maximum price of gas in cities having a population of over 500,000 and less than 1,250,000 at \$1.50 per 1,000. So the new law, if it affects Brooklyn at all, reduces the price 10 cents per 1,000 in any event, whether the new census shall show the population to be over 800,000 or not. But there is some question whether Brooklyn will not still be governed by the special law

of 1887, rather than this new general law of 1890. It is a familiar principle of statutory interpretation frequently applied of late by our Court of Appeals that special and local laws are not repealed by subsequently general legislation unless the subsequent general law expressly indicates an intent of the Legislature to repeal the previous special law, and that such intent will not be presumed from mere general language (see 69 N. Y., 209, at p. 212, and cases cited). Nevertheless, it was with the expectation that the new law would be held to apply to Brooklyn, and that it would effect a reduction of 10 cents per 1,000 in the price of gas in that city, whatever its population should appear to be by the new census, that the bill was signed. There is not even room for argument that under previous laws the maximum price of gas in Brooklyn would continue at \$1.60 and would not be reduced to \$1.25 per 1,000 even if the new census should show a population in Brooklyn of over 1,000,000. No arguments or memoranda either for or against the bill had been filed with the Governor, and I suppose he acted upon my advice as to the effect of the bill upon previous legislation."

MR. J. PORTER WHITTIER, who makes a specialty of gasholder tank work and gas works masonry of all descriptions, has changed his headquarters from 499 Myrtle avenue, Brooklyn, to No. 70 Rush street, same city. Mr. Whittier's contracts in hand include a gasholder tank at Flatbush, L. I.

MR. JOHN CLUNE has been appointed Manager of the Brockport (N. Y.) Gas Light Company, vice G. H. Williams, resigned.

THE Board of Health, of East Liverpool, Ohio, has determined to so arrange the old gas plant (it has been unused for some time) that it may be employed as a garbage crematory.

AT the annual meeting of the Pawtucket (R. I.) Gas Company, Mr. Lyman M. Darling acted as President *pro tem.*, Mr. S. G. Stiness serving as Secretary. The annual reports were read and approved, after which the following Board of Directors was chosen: Darius Goff, Gideon L. Spencer, Lucius B. Darling, Geo. L. Walker, Edwin A. Perrin, Stephen Jenks, Olney Arnold, Lyman M. Darling, James G. Fales, Hezekiah Conant and Alfred H. Littlefield. The yearly reports were most flattering to the hopes of the proprietors.

THE residents of Oswego, N. Y., complain bitterly over the poor quality of the electric light supplied under the contract awarded to Mr. Graves.

THE proprietors of the Cleveland (Ohio) Gas Light and Coke Company are again arranging for an extension of their works. This time the betterments are to consist of additional retort house plant, and a new holder, rated to hold one million cubic feet. The growth of Cleveland in population and wealth is little short of surprising, and it goes without saying that the Cleveland Gas Company is keeping up with the procession.

THE following, from the *Chicago Herald*, of 3d inst., will show that the Connelly motor is almost ready for marketing on a large scale: "The Connelly gas motor which the property owners on West Lake street were promised some months ago in lieu of a cable system was formally tried yesterday afternoon. The machine performed all its owners claimed for it, which was that it would work with efficiency and cleanliness and with a minimum amount of noise. The motor is light and airy in appearance, and neat in construction and finish. It weighs about 5,800 pounds, and in the run from Western avenue to Fortieth street fully demonstrated its strength. It drew an ordinary summer car which was comfortably filled, and made the distance, including stops, in about 8 minutes. The trailer jumped the track twice during the trip, but the little machine went on just as if nothing had happened, and readily proved its ability. The engine is a simple affair. The power is gained from the vapor of crude naphtha, which, on passing into a cylinder, is exploded by means of an electric spark supplied by a miniature dynamo. The first spark is produced by the turning of a small wheel with the hand, and in a second the explosion follows and the machinery is in motion. The subsequent action of the engine impels the dynamo, the naphtha vapor taking the place of steam, and thereafter the speed of the little worker depends on the frequency of the explosions, which are entirely in the control of the person in charge. It can be run with safety at the rate of 12 miles an hour at a cost of \$1.50 a day, and it is so easily manipulated that a schoolboy could be educated to run it in 30 minutes. Further trials of the device will be made, and if it meets the approval of the West Side Railroad Company it will probably be put in regular service on several of the streets of that division as a present means of solving the rapid transit question."

Position Wanted

As Superintendent of Gas Works, or Gas, Electric Light, or Water Works.

Have been Superintendent of gas works for the past 17 years. Formerly acted as Superintendent of water works. Can give the best of references. DAN'L DOUGHERTY,
Late Supt. Jeffersonville Gas Co.,
Jeffersonville, Ind.

784-1

SITUATION WANTED

As Superintendent of a Gas Works,

By a man of 20 years' experience. Best of references. Address

JOHN COLLINS,

324 Clinton Street,

Schenectady, N. Y.

789-1f

POSITION WANTED

As Superintendent of Gas Works.

Eleven years' experience in the manufacture of coal gas. Best of references given.

W. L. CARVER, Supt.,

Carthage, Mo.

778-8

**WANTED,
A Six-Inch Exhauster.**

SECOND-HAND.

Must be in good condition. Roots' make preferred. Address
POUGHKEEPSIE GAS CO.,
Poughkeepsie, N. Y.

783-

**WANTED TO LEASE,
A Small Gas Works,**

By a practical gas man. Address

784-8

"W. E. F." care this Journal.

FOR SALE.**GAS LIGHT PLANT,**

In a growing town of 5,000 inhabitants. Oil Gas Process.

For particulars address LATROBE GAS COMPANY,

784-5

Latrobe, Pa.

FOR SALE.**One 5-ft. Station Meter,**

8-inch Connections.

In good order Price, \$300. f.o.b. at Poughkeepsie, N. Y.

POUGHKEEPSIE GAS CO.,

783-1f

Poughkeepsie, N. Y.

Engines and Boilers For Sale

Five 80-H.P. Ft. W. Bass Automatic Cut-Off Engines, 12 by 16 in.

Three 40-H.P. Armington & Sims Automatic Cut-Off Engines, 9 by 12 in.

One 50-H.P. New York Safety Automatic Cut-Off Engine, 10 by 12 in.

Four Tubular Boilers, Steel, 16 ft. by 60 in., forty-four 4 in. flues. Full front.

Two Tubular Boilers, Steel, 16 ft. by 60 in., eighty 3-in. flues. Full front.

One No. 5 Dean Pump.

Three Sets J. H. Turner Patent Heaters.

The above are in good condition and in operation. Write for particulars.

JENNEY ELECTRIC LIGHT AND POWER CO.,

783-1f

Peoria, Ills.

**The New York Oxygen Co.,
No. 80 Broadway,**

Are prepared to give full information on the application of Oxygen to the purification of lighting gas.

FOR SALE,

The Ironwork for Ten Benches of Fives (5's).

Cast iron Hydraulic Main, 16 by 18 in. Stand Pipes, 5 in. at bottom, 4 in. at top. Bridge and Dip Pipes, 4 in. Address

DAYTON GAS LIGHT AND COKE CO.,

783-1f

120 East Third Street, Dayton, Ohio.

FOR SALE,

The Ironwork for Twelve Benches of 6's, viz.:

Cast Iron Hydraulic Main.

7-inch Dip-Pipes, Stand-Pipes, and Bridge-Pipes, complete.

Floyd Mouthpieces and Self-Sealing Lids, 15x26 in.

Lids and Mouthpieces only in use over a year. Will be sold cheap.

ISAAC C. BAXTER,

772-1f

Detroit (Mich.) Gas Lt. Co.

Fuel and Its Applications.

By E. J. MILLS, D.Sc. F.R.S., and F. J. ROWAN, C.E., assisted by others, including Mr. F. P. Dewey, of the

Smithsonian Inst., Wash., D. C.

7 PLATES, AND 607 OTHER ILLUSTRATIONS. ROYAL OCTAVO, PAGES XX, 802. HANDSOME CLOTH, \$7.50.

A. M. CALLENDER & CO., 42 Pine St., N. Y.

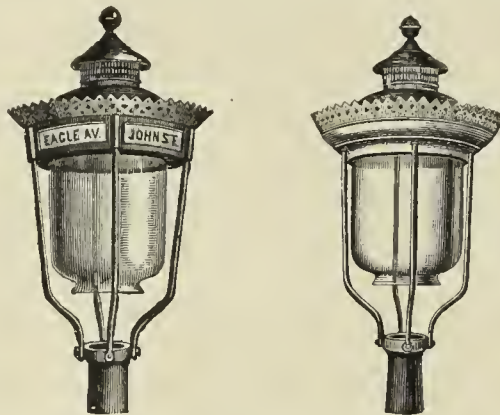
**The Miner Street Lamps.
Jacob G. Miner,**

No. 823 Eagle Ave., New York, N. Y.

Simpkin & Hillyer

RICHMOND, VA.

MANUFACTURERS OF

Gas Works Apparatus

BENCH CASTINGS, CONDENSERS,

Scrubbers, Purifiers, Dry Center Seals,

FOUR-WAY VALVES, GAS VALVES,

SULPHATE OF AMMONIA APPARATUS, TANKS, ENGINES, BOILERS, PUMPS, ETC., ETC.

Plans, Specifications and Estimates furnished for new works, or alteration of old works. Correspondence solicited. Works, Newport News, Va.

**Bartlett Street Lamp Mfg. Co.**

MANUFACTURERS OF

Globe Lamps,

FOR

Streets, Parks, Public Buildings, Railroad Stations, etc.

LAMP POSTS

A Specialty.

Office and Salesroom,
40 & 42 COLLEGE PLACE, - - N. Y. CITY.

Gas Companies and others intending to erect Lamps and Posts will do well to communicate with us.

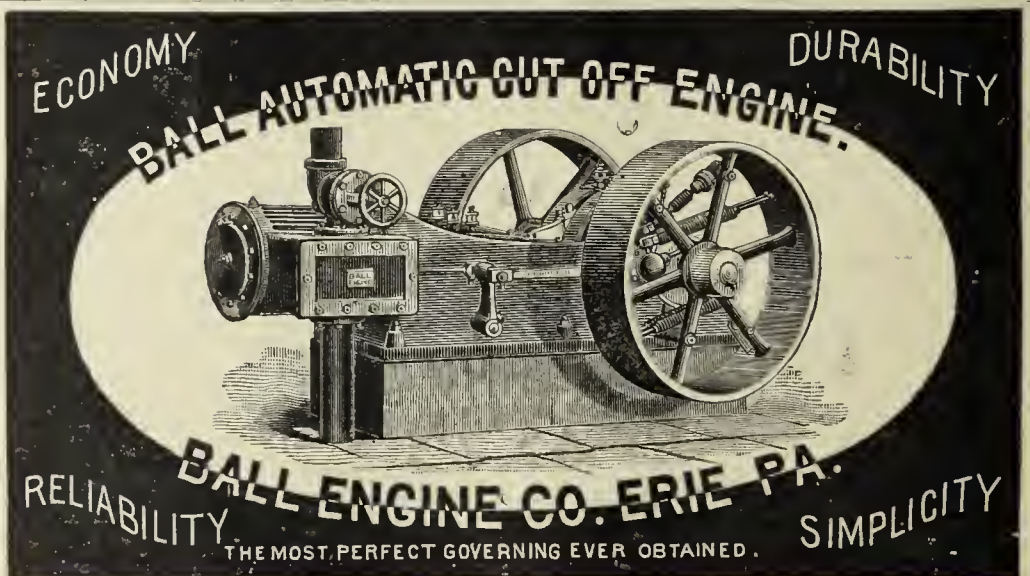
**The New York Oxygen Co.,**

No. 80 Broadway,

Are prepared to give full information on the application of Oxygen to the purification of lighting gas.

GASHOLDER PAINT.

Use Only

THE GOVERNMENT WATERPROOF PAINT.

Proof against Ammonia, and Absolutely Waterproof. Send for Prices and Particulars.

THE GOVERNMENT WATERPROOF PAINT CO., 122 Milk Street, Boston, Mass.

FORT WAYNE ELECTRIC CO.

FORT WAYNE, IND.

MANUFACTURERS OF THE

Slattery Induction System

—OF—

LONG DISTANCE INCANDESCENT LIGHTING.

The Most Carefully Worked Out and Complete Alternating Current System of Electric Lighting in Existence.

—AND THE—

WOOD

Automatically Regulating
ARC DYNAMOS and LAMPS.

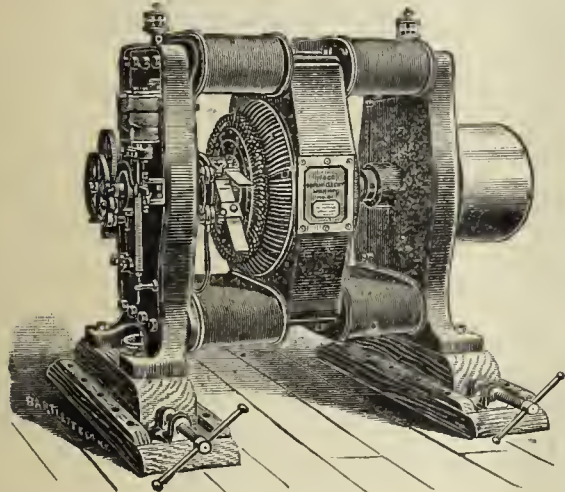

Wood Dynamo.

Main Office, - - - Fort Wayne, Indiana.

Factories: Fort Wayne, Ind.; Brooklyn, N. Y.

BRANCH OFFICES.

NEW YORK, - - - - -	115 Broadway.	DETROIT, MICH., - - - - -	57 Gratiot Avenue.
PHILADELPHIA, - - - - -	907 Filbert Street.	TORONTO, CANADA, - - - - -	138 King Street, West.
CHICAGO, - - - - -	185 Dearborn Street.	MEXICO, F. Adams' Successors, - - - - -	City of Mexico.
SAN FRANCISCO, - - - - -	35 New Montgomery Street.	CUBA, Maicas & Co., - - - - -	Havana

LACLEDE FIRE BRICK MANUFACTURING COMPANY,

ST. LOUIS, MO.

Exclusive Agents in the United States

FOR THE

Coze System of Inclined Retorts.

IT IS THE COMING BENCH
FOR MAKING COAL GAS.

*It will Save from 50 to
60 per ct. in Labor.*

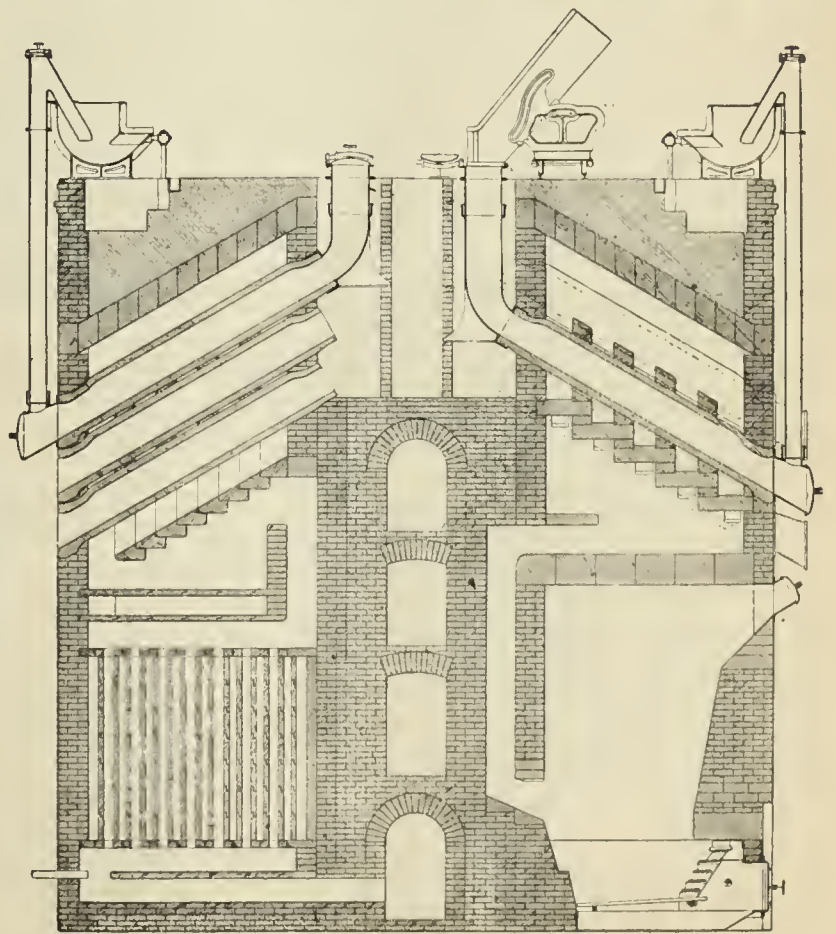
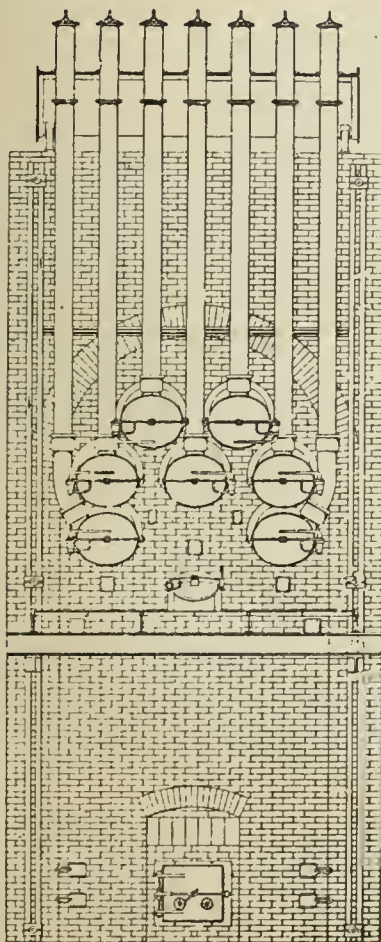

ESTIMATES AND PLANS FURNISHED BY THE

LACLEDE FIRE BRICK MFG. CO., ST. LOUIS, MO.

The Gordon Portico Lamp.

A successful Competitor of the Arc Electric Light for lighting Store Fronts, Show Windows, Depots, Railway Sheds, etc., etc.

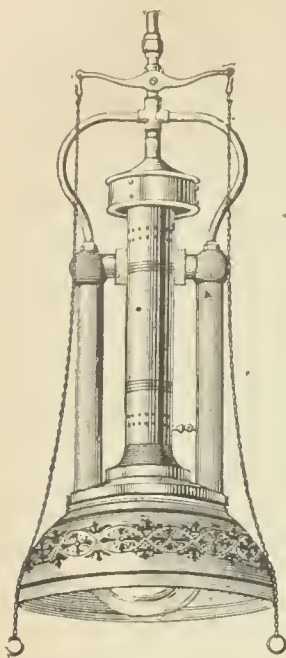

Gordon Portico Lamp.

The Gordon Street Lamp.

A Successful Competitor of the Arc Electric Light for lighting Streets, etc., etc.

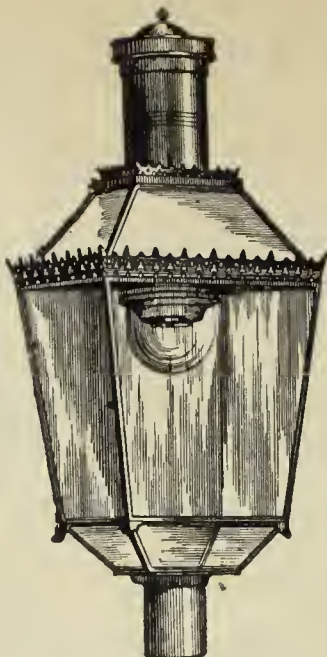

Gordon Street Lamp.

The Lungren Lamp.

A Successful Competitor of the Incandescent Electric Light for Interiors, etc. Is especially applicable for the lighting of Offices, Stores, Factories, Mills, Show Windows, Libraries, and all situations where an increased illumination is desired.

More than 25,000 Lungren Lamps are now in use. Testimonials, references, or any desired information will be cheerfully given.



Lungren Lamp.

THE SIEMENS-LUNGREN CO., N.E. Cor. 21st St. & Washington Av., PHILADELPHIA.

WELSBACH SYSTEM OF Incandescent Gas Lighting.

OFFICE, DREXEL BUILDING, PHILA., PA.

At the Fall Session of the Board of Supervisors of Winnebago County, held at the County Court House, Oshkosh, Wis., Nov. 26, 1889, the report submitted by Mr. C. W. Cook, Chairman of the Committee on Public Buildings, recommending the use of the Welsbach Incandescent Gas Burner in the Buildings under their charge, was unanimously adopted, because of the extreme economy in the consumption of Gas and the superior character of the light obtained.

MOSES G. WILDER, MECH. ENGR.

816-18-20-22 Cherry St., Phila., Pa.

Volumetric Lamp Governors

FOR GAS LAMPS & HIGH-POWER BURNERS.

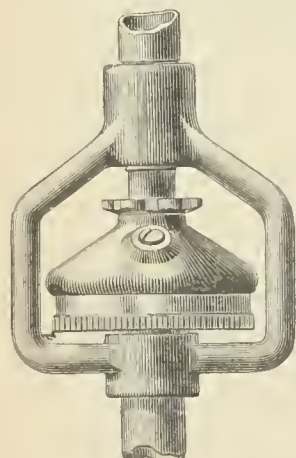

GOVERNOR BURNERS

for

STREET LAMPS AND
GENERAL USE,

and

GOVERNORS FOR ARGAND
AND OTHER COMMON GAS
BURNERS IN ALL SIZES.

HORIZONTAL
Governors

Specially adapted for
GAS STOVES, FURNACES,
Etc., Etc.

It is well known that a large majority of all High Power Gas Lamps in the United States have my Governors attached, and they are always used by the leading makers of these lamps. To remove any excuse for the use by anyone of inferior and infringing Governors, a reduction in price has been made, and all exclusive contracts are cancelled.

Correspondence Solicited with all who require a Reliable Governor.

FRIEDRICH LUX,

Ludwigshafen am Rhein and London.

Lux Mass
GAS GOVERNORS,
Gas Balance.

EDGEWATER LIME WORKS

Chas. F. McKenna, Proprietor.

SHELL LIME.

Lime by the Cargo for Gas Purification.

EDGEWATER, BERGEN CO., N. J.

Write for Testimonials and Prices.

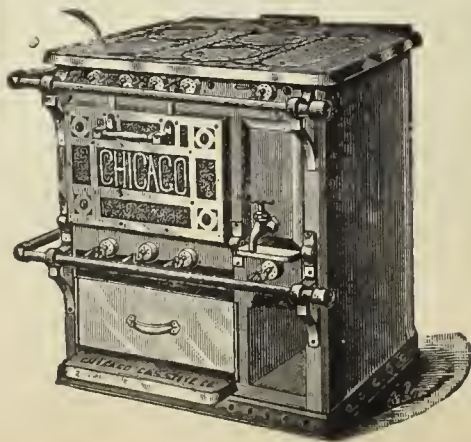

CHICAGO GAS STOVE CO.

MANUFACTURERS OF ALL KINDS OF

Gas Cooking and Heating
APPLIANCES.

117-119 Lake St., CHICAGO.

Send for Catalogue.

JEWEL GAS STOVES

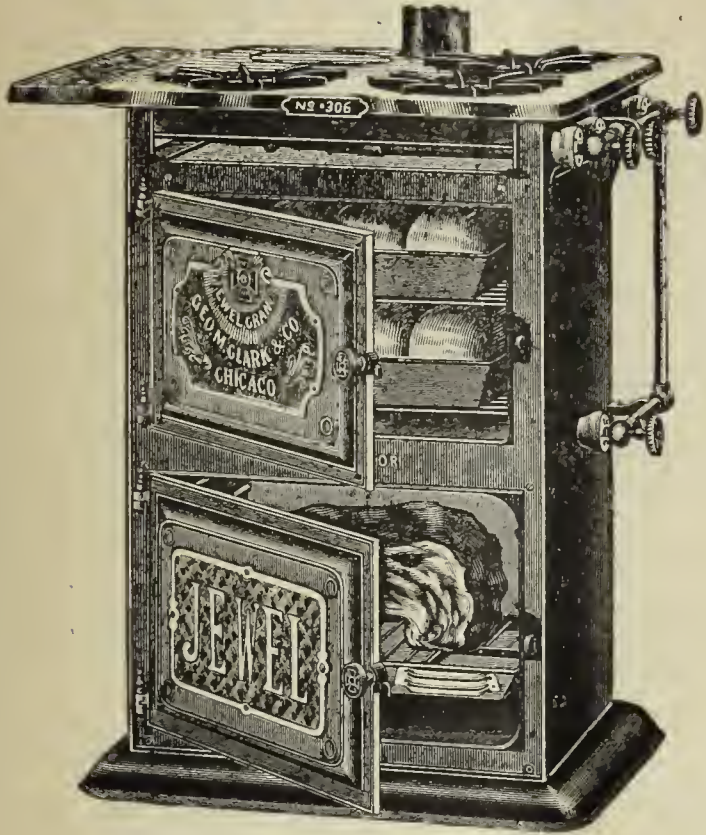

Are Best,

BECAUSE THEY ARE

HIGH GRADE,

Interchangeable,

RIGHT!

WE USE NO GAS COCKS.

All Flames are Regulated by Direct Needle Valves.

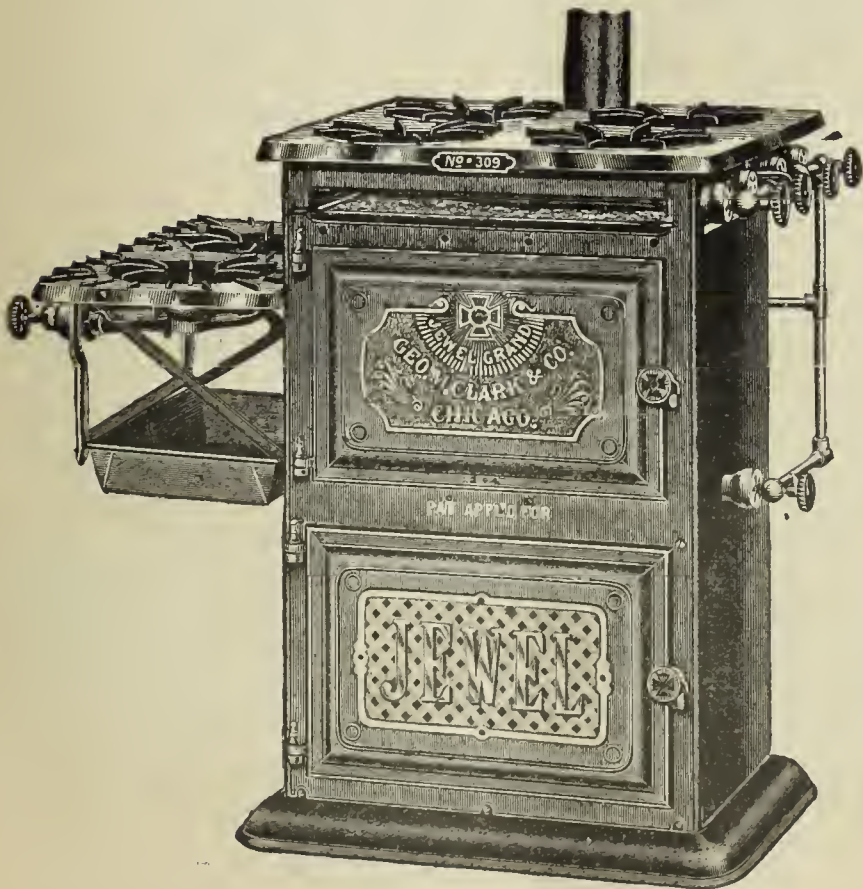

JEWEL CIRCULATING WATER HEATER.

No. 510, - - - - \$15.00.

Write for Jewel 1890
Catalog.

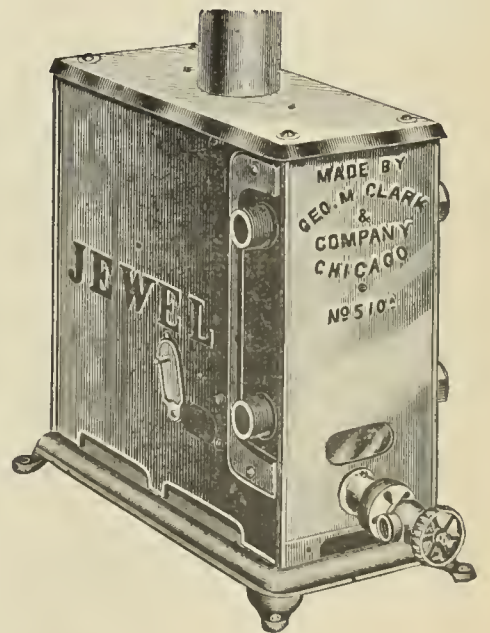

GEORGE M. CLARK & COMPANY,

MANUFACTURERS,

157 & 159 Superior Street, - - - Chicago, Ill.

NATIONAL GAS LIGHT AND FUEL CO.,

218 La Salle Street, Chicago.

C. D. HAUK, Prest. & Gen'l Manager.

A. W. GREEN, Vice-Prest.

N. A. McCLARY, Sec. & Treas.

E. E. MORRELL, Engr.

GAS WORKS

Built, Remodeled, Leased, and Purchased.

71 Springer Cupolas have been installed in the U. S. during the past four years.

The total capacity of Springer Apparatus now in use is over 25,000,000 ft. daily.

THE SPRINGER CUPOLA SYSTEM

Has Proven Itself the most Economical and Satisfactory Method of Gas Manufacture ever brought to the attention of the Gas Fraternity.

GUARANTEED ESTIMATES of Cost of Gas Furnished on Application.

GASHOLDER TANK CONSTRUCTION, ETC.

Gas Companies and others about to erect Gasholders will find it profitable to consult W. C. Whyte, who for over 30 years has made a specialty of

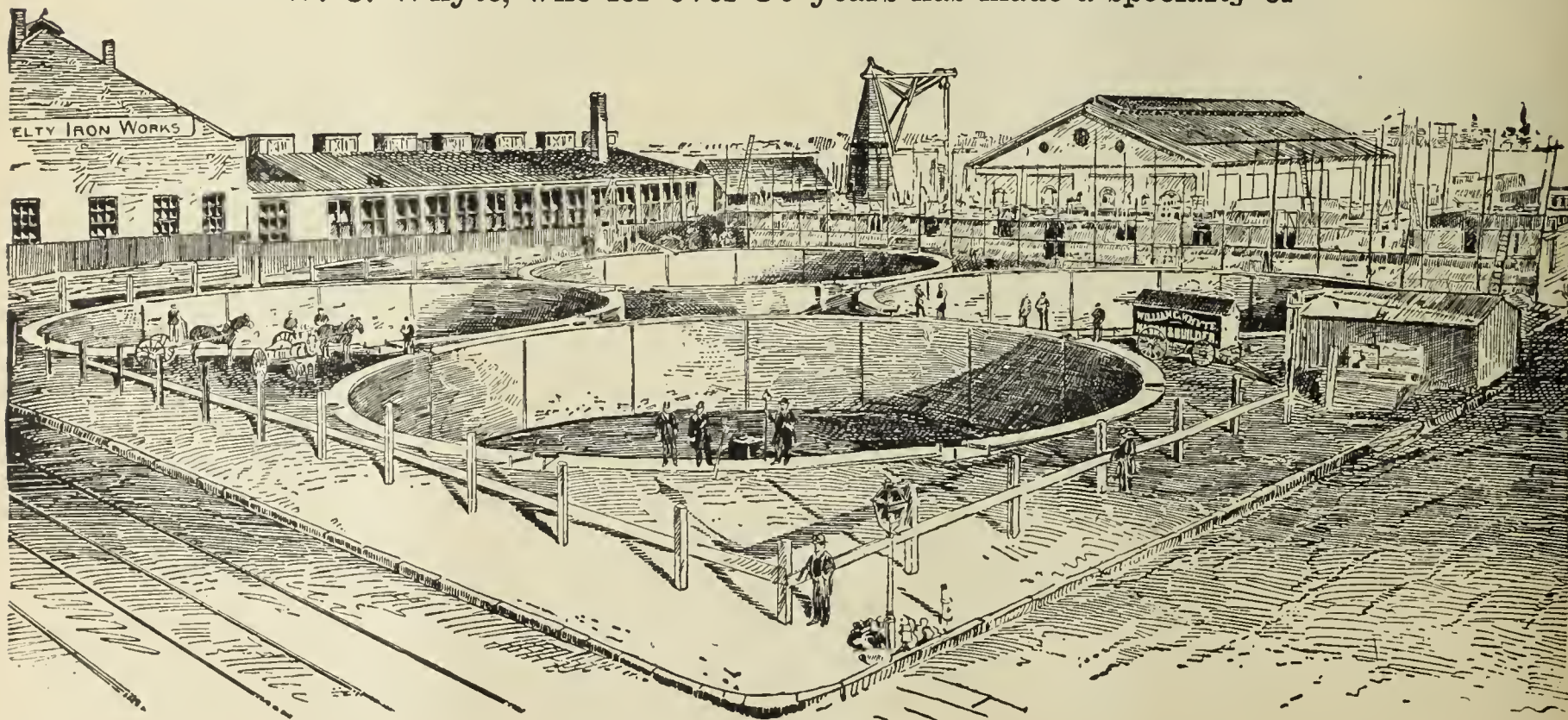

Tank Excavation and Mason Work.

Fifty Tanks now in operation show the sort of work done. Address

W. C. WHYTE, - No. 15 Cortlandt Street, N. Y. City.

GAS STOVES.

GAS METERS.

GAS STOVES.

THE AMERICAN METER CO.

Established 1834.

Incorporated 1863.

MANUFACTURERS OF

Gas Meters,

STATION METERS,

METER PROVERS, PHOTOMETERS,

Pressure Gauges of all Kinds,

AND



Standard 3 Diaphragm Dry Meter.

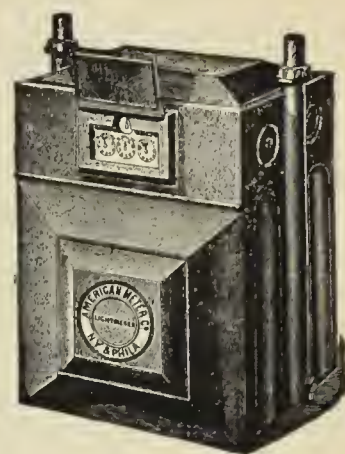

Standard 2 Diaphragm Dry Meter.

Apparatus for Testing the Quantity and Quality of Gases.

GAS STOVES FOR HEATING AND COOKING.



Circulars and Price Lists on Application.

MANUFACTORIES,

508 to 514 West Twenty-second St., N. Y.

Arch and Twenty-second St., Phila.

Nos. 244 & 246 North Wells Street, Chicago, Ill.

AGENCIES,

No. 177 Elm Street, Cincinnati, Ohio.

No. 222 Sutter Street, San Francisco, Cal.

No. 810 North Second Street, St. Louis, Mo.

GAS STOVE SHOW ROOMS, No. 242 Sixth Avenue, New York City.

KIRKHAM, HULETT & CHANDLER, LIMITED.

PATENT "STANDARD" WASHER-SCRUBBERS
Erected and in course of construction at present date:

Capacity. Cubic feet per day.	Capacity. Cubic feet per day.	Capacity. Cubic feet per day.	Capacity. Cubic feet per day.
Altrincham..... 600,000	Dublin..... 3,000,000	LONDON—Continued.	Ober Schlesian..... 1,500,000
Adelaide..... 600,000	Dowlais..... 100,000	Shoreditch..... 2,500,000	Otto & Co.'s Coke Works..... 1,500,000
Aldershot..... 200,000	Donai..... 500,000	Panaras..... 1,500,000	Plymouth..... 2,000,000
Allegheny, U. S. A..... 1,000,000	Deuton..... 500,000	"..... 1,500,000	Parramatta, N. S. W..... 100,000
Ashou-under-Lyne..... 1,250,000	Derby, U.S.A..... 350,000	Pimlico..... 2,000,000	Prescott..... 150,000
Amsterdam..... 1,500,000	Denver, "..... 500,000	Nine Elms..... 3,000,000	Providence, U.S.A..... 750,000
"..... 1,500,000	Dusseldorf..... 1,000,000	"..... 3,000,000	Plauen..... 300,000
Annaberg..... 200,000	"..... 750,000	South Metropolitan Co:—	"..... 300,000
Areachou..... 100,000	"..... 500,000	Greenwich..... 3,000,000	Portsmouth..... 2,500,000
Animal Charcoal Co..... 200,000	Dumfries..... 250,000	Woolwich..... 400,000	"..... 2,500,000
Altoona, U.S.A..... 350,000	Dunedin, N.Z..... 400,000	Vauxhall..... 3,000,000	Pittsburgh, U.S.A..... 1,500,000
Buxton..... 250,000	Darlington..... 1,250,000	"..... 3,000,000	Portland, "..... 560,000
Bradford..... 1,000,000	Detroit, U.S.A..... 750,000	Lea Bridge..... 300,000	Pawtucket, "..... 500,000
"..... 1,250,000	Edinburgh..... 1,500,000	West Ham..... 1,500,000	Quebec..... 250,000
"..... 1,250,000	"..... 2,000,000	Leeds..... 2,000,000	Radelife..... 750,000
"..... 1,250,000	Enfield..... 300,000	"..... 3,000,000	Rouen..... 250,000
"..... 1,000,000	Essen..... 300,000	"..... 3,000,000	Ramsgate..... 1,000,000
"..... 1,000,000	Elbing..... 150,000	"..... 3,000,000	Reigate..... 200,000
"..... 3,000,000	Falmouth..... 150,000	"..... 3,000,000	Richmond, U.S.A..... 250,000
Bremen..... 150,000	Frankfort..... 300,000	"..... 3,000,000	Roxbury, "..... 500,000
Baltimore, U.S.A..... 1,000,000	Farnworth..... 400,000	"..... 3,000,000	Runcorn Soap Co..... 20,000
"..... 1,000,000	Fenton..... 400,000	"..... 2,000,000	Rockhampton, N. S. W..... 125,000
"..... 1,000,000	Friedenshutte..... 500,000	Leominster..... 150,000	Richmond..... 1,500,000
Calmain, N.S.W..... 125,000	Furth..... 400,000	Leiden..... 560,000	Reading..... 2,000,000
Bishops Stortford..... 150,000	Freiburg..... 200,000	"..... 600,000	Reichenbach..... 200,000
Blackpool..... 400,000	Goole..... 250,000	Liverpool..... 2,000,000	Salford..... 1,750,000
Brussels..... 1,250,000	Glossop..... 300,000	"..... 2,000,000	"..... 1,750,000
"..... 1,250,000	Guildford..... 300,000	"..... 2,000,000	"..... 1,750,000
"..... 1,250,000	Gloucester..... 1,250,000	"..... 2,000,000	Smethwick..... 750,000
Banbury..... 250,000	Gera..... 300,000	"..... 2,000,000	Sydney, N. S. W..... 1,000,000
Birmingham..... 5,000,000	Grafton, N.S.W..... 100,000	"..... 2,000,000	"..... 1,000,000
Birkenhead..... 2,500,000	Greig..... 300,000	"..... 3,000,000	"..... 2,500,000
Blackburn..... 1,500,000	Georgetown, U.S.A..... 250,000	Lincoln..... 1,000,000	"..... 50,000
Bochum..... 600,000	Gleekauf..... 200,000	"..... 600,000	Sunderland..... 1,500,000
Burntisland..... 250,000	Heywood..... 600,000	Lowell, U. S. A..... 1,000,000	St. Josephs, U.S.A..... 250,000
Boston, U.S.A..... 2,000,000	Holywood..... 125,000	Louisville "..... 1,500,000	Spa..... 100,000
Brisbane..... 1,500,000	Huy..... 70,000	Long Eaton..... 500,000	Sevenoaks..... 300,000
"..... 300,000	Harrow..... 250,000	Lilie..... 900,000	St. Petersburg..... 2,000,000
Burton-on-Trent..... 1,500,000	Harrogate..... 250,000	"..... 450,000	"..... 1,500,000
Barcelona..... 350,000	Halstead..... 150,000	"..... 750,000	St. Louis, U.S.A..... 2,000,000
Barking..... 100,000	Heilbronn..... 200,000	"..... 250,000	"..... 2,000,000
Baerlien & Co..... 20,000	Havana, Cuba..... 750,000	"..... 250,000	Laclede..... 1,000,000
"..... 20,000	Hastings..... 1,500,000	Luckenwalde..... 330,000	Silesian Coal Co..... 600,000
Bombay..... 400,000	Huddersfield..... 300,000	Liegnitz..... 300,000	San Francisco, U.S.A..... 2,000,000
Buffalo, U.S.A., Mutual..... 750,000	"..... 750,000	Lincoln, U. S. A..... 250,000	"..... 2,000,000
"..... Citizen..... 500,000	"..... 1,500,000	Lawrence "..... 500,000	Sheepbridge Coal Co..... 40,000
Brookline, U.S.A..... 500,000	Hof..... 200,000	Lynn "..... 300,000	Stettin..... 200,000
Bergen..... 350,000	Hampton Wick..... 500,000	Lyons..... 1,500,000	Siapapore..... 300,000
Berlin..... 1,250,000	Heckmondwike..... 500,000	Maidstone..... 1,000,000	Sutton..... 500,000
Bournemouth..... 1,000,000	Haverfordwest..... 100,000	Marseilles..... 1,500,000	Tonbridge..... 150,000
Bridgeport, U.S.A..... 500,000	Halifax, N.S..... 350,000	"..... 1,500,000	Tiptou..... 400,000
Bruuswick..... 300,000	Ham..... 200,000	Mons..... 500,000	Tottenham..... 1,000,000
Beck & Co., St. Louis..... 100,000	Halle..... 400,000	Malines..... 250,000	Toledo, U.S.A..... 750,000
Barmen Rittershausen..... 600,000	Heidelberg..... 300,000	Melbourne..... 1,500,000	Toronto..... 1,000,000
Bexhill..... 125,000	Hartford, U.S.A..... 1,000,000	"..... 1,500,000	Uxbridge..... 300,000
Brooklyn, U.S.A..... 1,000,000	Ilkeston..... 300,000	"..... 1,500,000	Valparaiso..... 500,000
"..... Nassau..... 1,000,000	Inverness..... 250,000	Manchester..... 2,500,000	West Bromwich..... 1,000,000
Brunner, Mond & Co..... 400,000	Ilkley..... 200,000	Middleton..... 400,000	Willenhall..... 250,000
Cheltenham..... 2,000,000	Ilford..... 100,000	Manley, N. S. W..... 100,000	Weston super-Mare..... 500,000
Cannes..... 200,000	Kingstou-on-Hull..... 400,000	Minneapolis, U. S. A..... 750,000	Waltham..... 150,000
Croydon..... 1,500,000	Kidderminster..... 750,000	Magdeburg..... 300,000	Wormwood Scrubs..... 300,000
Copenhagen..... 200,000	Kidsgrove..... 100,000	Memphis, U. S. A..... 750,000	Williamsburg, U.S.A..... 600,000
Cleveland..... 200,000	Konigberg..... 1,000,000	Nottingham..... 1,250,000	"..... 600,000
Columbus, U.S.A..... 500,000	King's Lynn..... 300,000	"..... 2,500,000	Wellington..... 150,000
Cincinnati, "..... 1,500,000	LONDON:—	"..... 2,500,000	Warwick..... 300,000
"..... 1,500,000	The Gaslight and Coke Co.:	"..... 2,000,000	Wheeling, U.S.A..... 500,000
Chicago..... 3,000,000	Beckton..... 1,250,000	"..... 1,500,000	Walker..... 300,000
"..... 1,000,000	"..... 1,250,000	Newport, U.S.A..... 430,000	Westgate..... 100,000
"..... 1,000,000	"..... 1,250,000	Newmarket..... 150,000	Wilmington, U.S.A..... 500,000
Chemnitz..... 1,000,000	"..... 1,250,000	Newark, U.S.A..... 680,000	Windsor, N. S. W..... 100,000
Crewe..... 1,250,000	"..... 1,250,000	Northfleet..... 200,000	Wolverton..... 100,000
Colonial Gas Works Co..... 100,000	"..... 2,500,000	New York, U.S.A..... 2,000,000	Wellington, N. Z..... 250,000
Cadiz..... 300,000	"..... 2,500,000	Nice..... 600,000	Whitechurch..... 175,000
Charlottenburg..... 600,000	Silvertown..... 1,000,000	Newcastle, N. S. W..... 200,000	Washington, U.S.A..... 2,000,000
Dudley..... 750,000	Bromley..... 2,000,000	Numea, "..... 100,000	Wallasey..... 750,000
Driffild..... 100,000	"..... 1,500,000	Namur..... 250,000	Weimar..... 150,000
Dukenfield..... 500,000	"..... 1,500,000	Newark..... 350,000	Wurzen..... 200,000
Dover..... 750,000	"..... 1,500,000	Oldbury..... 500,000	Worcester, U.S.A..... 750,000
"..... 1,000,000	"..... 2,000,000	Otley..... 200,000	Yeaddon..... 500,000
Deal..... 200,000	"..... 1,500,000	Oswestry..... 250,000	Yeovil..... 250,000
Derby..... 1,500,000			

SOLE AGENT FOR WESTERN HEMISPHERE,
GEO. SHEPARD PAGE, 69 WALL STREET, NEW YORK

THE UNITED GAS IMPROVEMENT CO.,

DREXEL BUILDING, PHILA., PA.

Owners of the Lowe, Granger-Collins, McKay-Critchlow (for carbureting Natural Gas), and Other Gas Patents.

BUILDERS, LESSORS *and* PURCHASERS OF GAS WORKS.

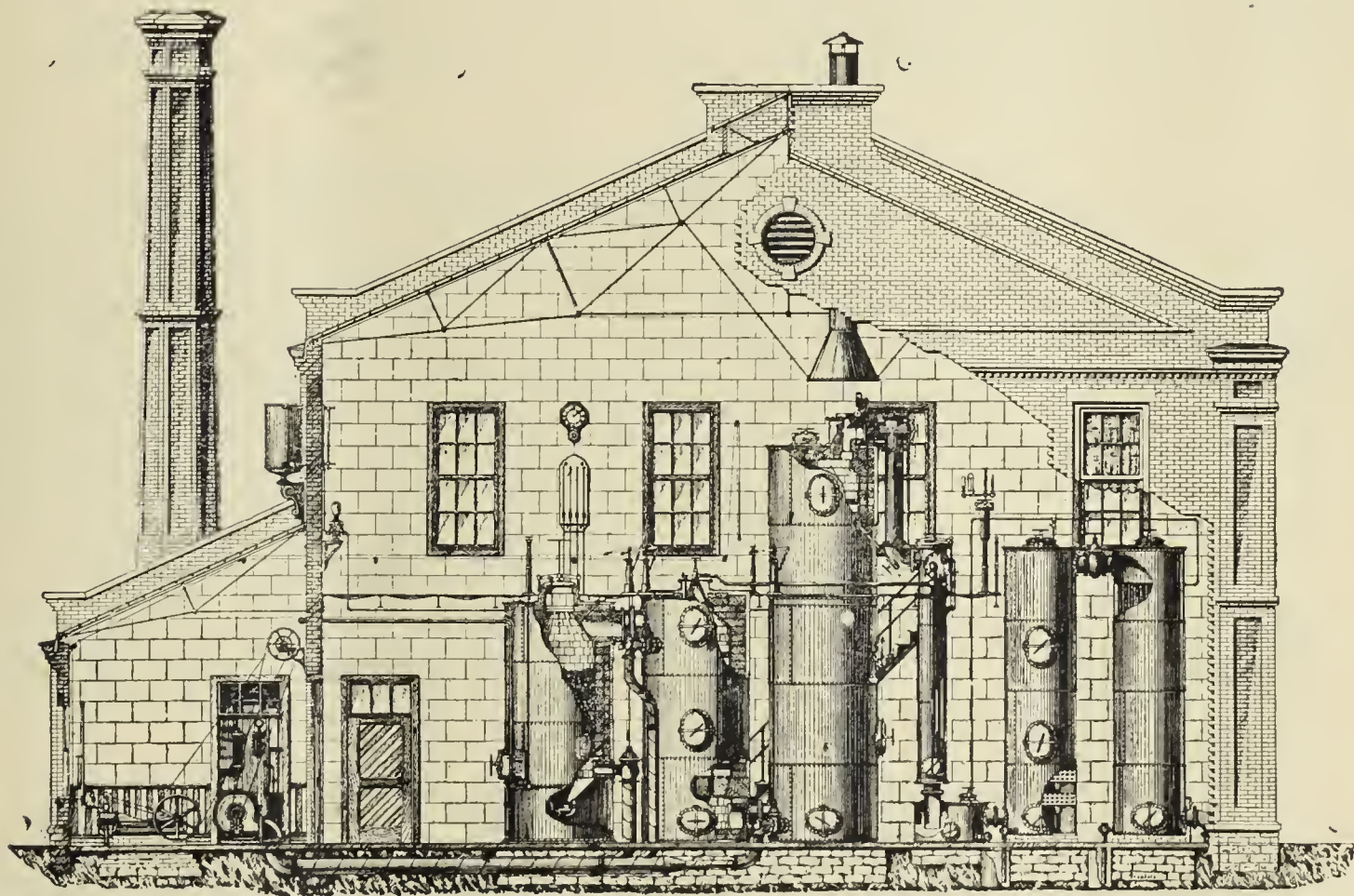

Standard "Double Superheater" Lowe Apparatus, Especially Designed for the Use of Lima Crude Oil.

Erectors of

WATER GAS PLANTS,

(Either Independent or Auxiliary to Coal Gas Works),

USING LIMA OR OTHER LOW GRADE OILS AND ANTHRACITE COAL OR GAS HOUSE OR OVEN COKE.

PAMPHLETS, PLANS, AND ESTIMATES FURNISHED UPON APPLICATION.

ROOTS' GAS AND BYE-PASS VALVES.

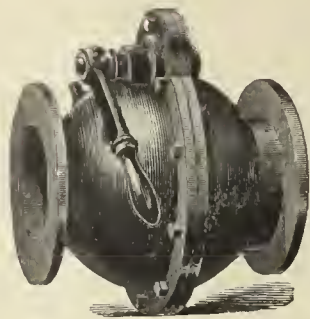

GAS VALVE

Quick Acting,
Simple,
Efficient, Durable.

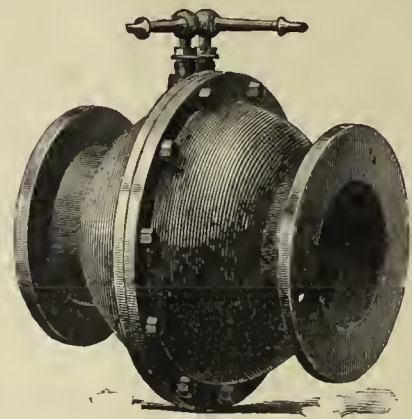

BYE-PASS VALVE.

Automatic Action
Reliable
Simple Durable.

Thousands now in use and giving perfect satisfaction. Write for Catalogue and Prices.

ROOTS' NEW GAS EXHAUSTER.

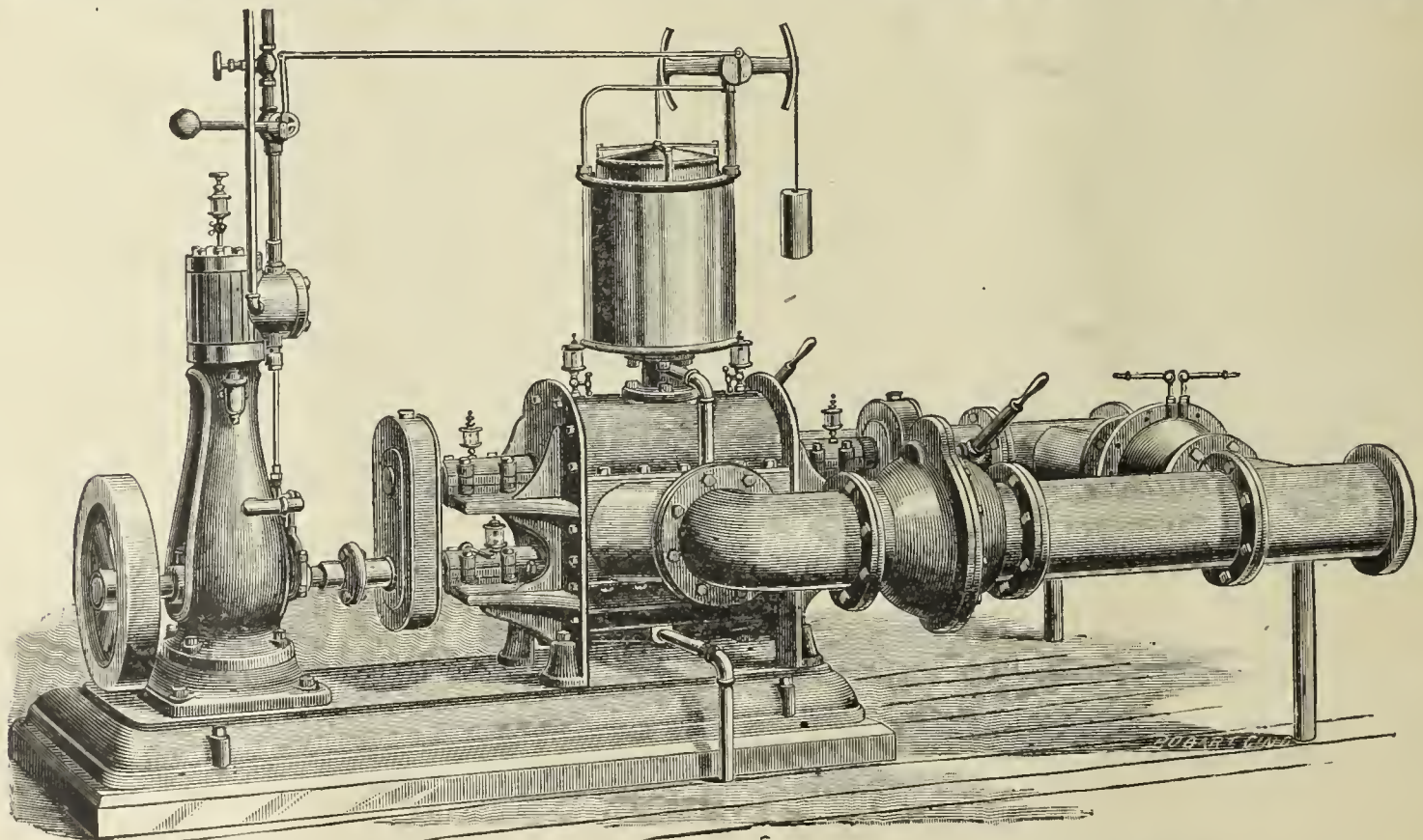

We will take pleasure in furnishing estimates on complete plants, including **CASEXHAUSTER, ENGINE,** and **GAS GOVERNOR,** all connected, complete, on same bedplate. Also, estimates for **GAS VALVES, BYE-PASS VALVES,** and **PIPE FITTINGS,** arranged in any manner to suit the exhauster room or main connections.

All flanges of pipe and valve fittings faced off, with bolt holes drilled, all ready to go together.

S. S. TOWNSEND, General Agent, }
COOKE & CO., Selling Agents, } 22 Cortlandt St., N. Y. P. H. & F. M. ROOTS CO., Connerville, Ind.

CONNELLY & CO.,

SOLE MANUFACTURERS OF THEIR PATENTED SPECIALTIES.

"IRON SPONGE." Saves money, saves labor, and is the most efficient purifying agent ever offered as a substitute for lime. Now used in every State in the Union, and purifying daily over thirty-five million cubic feet. Should be used in every gas works. Its own saving will pay for it many times over.

AUTOMATIC GOVERNOR. Has been on the market but three years, and in that time has been introduced more generally than any invention ever designed for use in gas works. Over two hundred of them now in use. Sensitive; reliable; perfectly automatic; reduces leakage; satisfies consumers, and gives great relief to the Manager. No gas works is complete without one of these machines.

STEAM JET EXHAUSTER. Designed particularly for small works. Combines Exhaust Tube, Steam Governor Gas Compensator, and Bye-Pass Valves in the most compact form possible; occupies but little space; uses very little steam; operated by ordinary workmen; saves formation of carbon in retorts; increases yield 10 to 15 per cent. Specially adapted for mixing air with oil gas. No works too small to use them profitably.

Prices given on all our specialties delivered at any point in the United States. Correspondence solicited.

CONNELLY & CO., No. 111 Broadway, New York City.

WILBRAHAM GAS EXHAUSTER

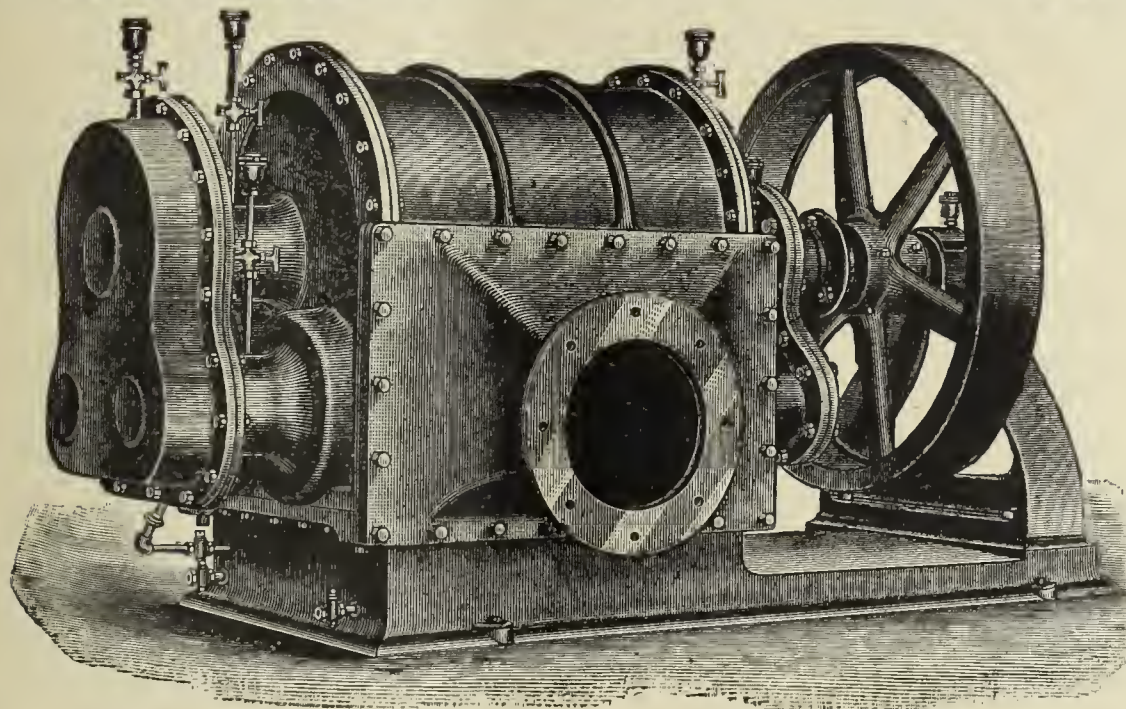

WILBRAHAM BROS.,
PHILADELPHIA, PA.

JARVIS ENGINEERING CO.,

61 Oliver St., Boston, Mass.

CONTRACTORS FOR ERECTING

COMPLETE STEAM OUTFITS FOR ELECTRIC LIGHTING STATIONS.

Steel Boilers set with Jarvis Pat. Boiler Setting

To burn **COKE SCREENINGS** for Fuel.

ARMINGTON & SIMS CO. ENGINES,

Belting direct to Dynamos, without using Shafting.

SEND FOR CIRCULARS.

REFERENCES.—Charlestown Gas & Electric Light Co., Charlestown, Mass.; Schenectady Gas & Electric Light Co., Schenectady N. Y.; Brookline Gas Co., Brookline, Mass.

Practical Electric Lighting

By A. BROMLEY HOLMES, A.M.I.C.E.

With 87 Illustrations. Third Edition. Price, \$1.00.

Electric Light Primer.

By CHARLES L. LEVEY.

A simple and comprehensive Digest of all the most important facts connected with the running of the Dynamo and Electric Lights, with Precautions for Safety, etc.

Price, 50 cents.

A. M. CALLENDER & CO., 42 Pine St., N. Y.

Gasholder Tanks & Gas Works Masonry Complete.

PLANS PREPARED AND ESTIMATES FURNISHED AT SHORT NOTICE.

J. P. WHITTIER, 70 Rush St., near Division Av., Brooklyn, N. Y.

1890 DIRECTORY 1890

OF THE GAS LIGHT COMPANIES of the UNITED STATES & CANADA.

Price, \$5.00.

A. M. CALLENDER & CO., No. 42 Pine Street, N. Y. City.

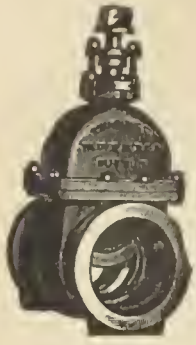

CHAPMAN VALVE MANUFACTURING CO.,

MANUFACTURERS OF

Valves and Gates for Gas, Ammonia, Water, Etc.

Also, Gate Fire Hydrants With and Without Independent Nozzle Valve. All Work Guaranteed.

WORKS & GEN'L OFFICE:
Indian Orchard, Mass.

TREASURER'S OFFICE:
72 Kilby & 112 Milk Sts, Boston, Mass.

LUDLOW VALVE MFG. CO.



OFFICE AND WORKS,

938 to 954 River Street and 67 to 83 Vail Av.,
TROY, N. Y.

Parson's Steam Blower,

FOR IMPROVING BAD DRAUGHT IN BOILERS, AND FOR BURNING BREEZE OR OTHER WASTE MATERIAL.

PARSON'S TAR BURNER,

FOR UTILIZING COAL TAR AS FUEL.

PARSON'S AIR JET TUBE CLEANER,

FOR CLEANING BOILER TUBES.

These devices are all first-class. They will be sent to any responsible party for trial. No sale unless satisfactory. Manufactured by the WATERTOWN STEAM BLOWER COMPANY.

H. E. PARSON. Supt., 33 & 35 Liberty St., N. Y.

MILLS' REVERSIBLE LIME TRAY,

AND

WOODWORK

Of Every Description

NEEDED BY GAS WORKS.

SEND FOR CIRCULAR AND PRICE LIST TO

BARTLETT, HAYWARD & CO.,

Pratt and Scott Streets, Baltimore, Md.

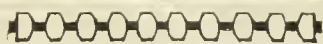
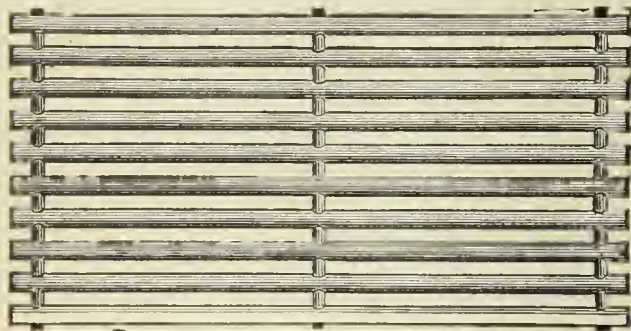

Hydraulic Main Dip Regulators, also Check Valves, Foot Valves, Yard-wash and Fire Hydrants. Send for Circulars.

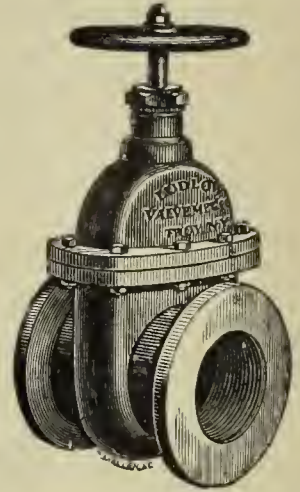

Valves.—Double and Single Gate, 1/2 in. to 48 in., outside and inside Screws. Indicator, etc., for Gas, Water, Steam, and Oil. Send for Circulars.

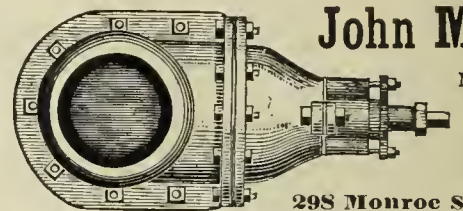

John McLean

Manufacturer

GAS

VALVES.

298 Monroe Street, N. Y.

VAN DUZEN GAS & GASOLINE ENGINE

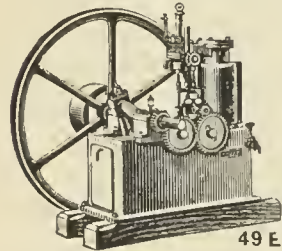

OPERATED with COAL and OTHER MANUFACTURED GASES AND GASOLINE.

RELIABLE AND ECONOMICAL.
Fully Warranted

VAN DUZEN Gas & Gasoline Engine Co.
49 E. 2d St., Cincinnati, O.

A. MacKinnon Machine Co., Agts., 22 Warren St., N. Y.

The Management of Small Gas Works.

BY C. J. R. HUMPHREYS.

Price, \$1.

Orders to be sent to **A. M. CALLENDER & CO.,**

42 PINE STREET, NEW YORK.

SPECIAL TRAYS FOR IRON SPONGE OR OXIDE OF IRON.
CHURCH'S TRAYS A SPECIALTY.

REVERSIBLE—STRONGEST—MOST DURABLE—MOST EASILY REPAIRED.

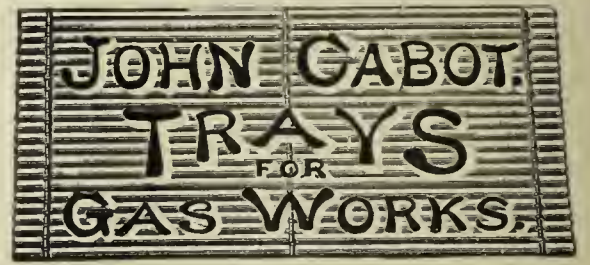

306-310 ELEVENTH AVENUE, NEW YORK.

WE ALSO MAKE THE CHEAPEST AND STRONGEST REVERSIBLE BOLTED TRAYS IN THE MARKET.

THE CLERK GAS ENGINE CO.,

Main Office, 1012, 1014, 1016, 1018 Filbert St., Philadelphia, Pa.

WM. W. GOODWIN, Prest.

E. STEIN, Sec.

S. LEWIS JONES, Asst. Sec.

A. J. DOTY, Supt.

The utility and convenience of the Gas Engine being no longer an open question, it only remains now for intending purchasers to select the BEST. We claim for the CLERK GAS ENGINE that it is equal to any other manufactured as regards steadiness in running, simplicity, and ease of keeping in repair, and that it gives the greatest amount of power for the least money (both in first cost and expense of running) of any engine made. In support of this claim we refer to the test of the Gas Engines made under the direction of the American Institute of New York, in December, 1885, and heretofore published in these columns. These engines are especially adapted for continuous running under heavy loads, and we can refer to Engines which have run 22 hours a day for months at a time

Made in Sizes of 5, 10, 15, 20, and 25 Horse Power. All Engines Guaranteed for One Year.

ENGINEERS.

P. D. WANNER, Chairman. A. H. MELLERT, Mangr. of Wks.
R. B. KINSEY, Secretary. F. A. KNOPP, Treasurer.

MELLERT FOUNDRY & MACHINE CO. Ltd.
and **READING FOUNDRY CO., Ltd.**
Reading, Pa.



Specials—Flange Pipe, Valves and Hydrants
Lamp Posts, Retorts, etc.
General Foundry and Machine Work.
JOHN FOX, Selling Agent. 160 Broadway, N.Y.

THE OHIO PIPE COMPANY,

MANUFACTURERS OF

Cast Iron Gas & Water Pipe,

BRANCH AND SPECIAL CASTINGS.

Gas-House Bench Castings, Hydraulics, Lamp Posts, Flange Pipe
and Specials, Architectural Castings, Building Columns,
Joists, Cellar Grates, Sash Weights, etc.

GENERAL FOUNDERS AND MACHINISTS.
Columbus, Ohio.

M. J. DRUMMOND,



SPECIAL CASTINGS AND LAMP POSTS.
Office, Corbin Building, 192 Broadway, N. Y.

EMAUS PIPE FOUNDRY.

DONALDSON IRON COMPANY. EMAUS, PA.



MANUFACTURERS OF

CAST IRON PIPE AND SPECIAL CASTINGS
FOR WATER AND GAS.

JOS. R. THOMAS,

No. 42 Pine Street, N.Y. City.

CONSULTING AND CONSTRUCTING
Gas Engineer and Contractor.

PLANS, SPECIFICATIONS, AND ESTIMATES
FURNISHED.

Contracts taken for all Appliances
required at a Gas Works,
Either for New Works or Extensions to Old Plants.

WM. MOONEY

(Successor to WM. FARMER)

No. 94 Liberty St., N Y. City.

GAS ENGINEER AND CONTRACTOR FOR THE ERECTION
OF GAS WORKS, OR APPARATUS OF ANY
CAPACITY.

Plans and Specifications Furnished.

WM. GARDNER,
Gas Engineer,

Lewis Block, Room 20, Pittsburgh, Pa.

Those who intend to make alterations in existing gas plants, or
who contemplate the erection of new works, will find it to their
interest to open correspondence with the above. Plans made
and estimates furnished.

GAS AND WATER PIPES.

SAM'L R. SHIPLEY, Pres.
HENRY B. CHEW, Tre

GLOUCESTER IRON WORKS,
GLOUCESTER CITY, N. J.



JAS. P. MICHELLON, Sec.
WM. SEXTON, Supt.

Cast Iron Gas & Water Pipes, Stop Valves, Fire Hydrants, Gasholders. &c.

Office, Rooms 61 and 63 Bullitt Building, 131 S. 4th St., Phila., Pa.

WARREN FOUNDRY AND MACHINE CO.,

Established 1856. Works at Phillipsburgh, N. J.

New York Office, 160 Broadway.

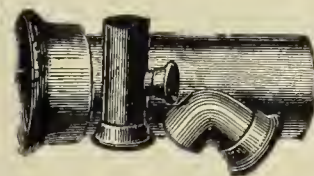

CAST IRON WATER AND GAS PIPE,

FROM TWO TO FORTY-EIGHT INCHES DIAMETER. ALSO, ALL SIZES OF

Flange Pipe for Sugar House and Mine Work. Branches, Bends, Retorts, etc., etc.

DENNIS LONG & COMPANY,

LOUISVILLE, KY.,



Manufacture Exclusively

**CAST IRON GAS & WATER PIPE & SPECIAL CASTINGS
OF ALL SIZES.**

King's Treatise on Coal Gas.

A standard text-book for the Engineers and Managers of Gas Works, and for all who are concerned
or take an interest in the manufacture and distribution of Coal Gas, and in the utilization of the
Secondary Products resulting therefrom; treating also of the Gas Engine, and of Gas Cooking and
Heating Appliances.

In 3 Vols. Price per Vol., \$10. Sold either by Volume or in Sets.

A. M. CALLENDER & CO., 42 Pine St., N. Y.

RETORTS AND FIRE BRICK.

RETORTS AND FIRE BRICK.

RETORTS AND FIRE BRICK.

J. H. GAUTIER & CO.,

CORNER OF

GREENE AND ESSEX STREETS,
JERSEY CITY, N. J.

MANUFACTURERS OF

**Clay Gas Retorts,
Gas House Tiles,
Fire Bricks, Etc. Etc.**Ground Clay, Fire Brick and
Fire Sand in Barrels,

J. H. GAUTIER. C. E. GREGORY. C. E. GAUTIER.

BROOKLYN**Clay Retort & Fire Brick Works,**
(EDWARD D. WHITE & CO.)Manufacturers of Clay Retorts, Fire Brick,
Gas House and other Tile.VAN DYKE, ELIZABETH, RICHARDS & PARTITION STS.
Office, 88 Van Dyke St., Brooklyn, N. Y.**LAGLEDE FIRE BRICK MFG. CO.,**

MANUFACTURERS OF

Fire Brick, Gas Retorts,

AND

ST. LOUIS STANDARD SEWER PIPE.Blast Furnace and Cupola Linings, every description of Fire
Clay Material, Fire Clay Flue Linings, Chimney Tops
Dry Milled and Crude Fire Clays, etc.

OFFICE AND DEPOT

901, 903, and 905 Pine Street,
ST. LOUIS, MO.

ESTABLISHED IN 1845.

B. KREISCHER & SONS,

OFFICE FOOT OF HOUSTON ST., E. R., N. Y.

Gas Retorts,**TILES, FIRE BRICK.**

AND EVERYTHING IN THE FIRE CLAY LINE.

MANHATTAN
FIRE BRICK & ENAMELLED CLAY
RETORT WORKS
ADAM WEBER.**CLAY GAS RETORTS
AND RETORT SETTINGS
FIRE BRICKS, TILES, ETC.,**

Office and Works, 15th Street and Avenue C., N. Y.

Works,
LOCKPORT STATION, PA.

—ESTABLISHED 1864.—

JAMES GARDNER, JR.,Office, Rooms 19 & 20, Lewis Block,
PITTSBURGH, PA., P. O. Box 373.

Successor to WILLIAM GARDNER & SON.

Fire Clay Goods for Gas Works.

H. A. NORTON, No. 4 CENTRAL STREET, BOSTON, MASS., Agent for the New England States.

GEO. C. HICKS,
Prest.**CHICAGO**CHAS. A. REED,
Sec. & Treas.**Retort and Fire Brick Co.,**

MANUFACTURERS OF

Fire Clay Goods of all Kinds,

AND BEST QUALITY ONLY.

Regenerative Furnaces & Water Gas Goods.

45th St., Clark to La Salle, Chicago.

GEROULD'S IMPROVED RETORT CEMENT.A Cement for patching retorts, putting on mouthpieces, and
making up all bench-work joints. This Cement is mixed ready
or use. Economic and thorough in its work. Fully warranted
o stick. For recommendations and price list address**C. L. GEROULD & CO.,**

5 & 7 Skillman St., Brooklyn, N. Y.

Western Agent, H. T. GEROULD, Mendota, Ill.

**Parker-Russell
Mining and Mfg. Co.,**

CITY OFFICE,

Mermod-Jaccard Bldg., Rooms 307 & 308,
Broadway & Locust St., St. Louis, Mo.

PROPRIETORS OF THE

OAKHILL GAS RETORT & FIRE BRICK W'KSOur immense establishment is now employed almost entirely in
the manufacture of**Materials for Gas Companies**We have studied and perfected three important points. Our re-
torts are made to stand changes of temperature, the strongest
heats of the furnace, and the abrasion of feeding and emptying.
We have the *exclusive Agency for the West* of the celebrated**Kloenne-Bredel Full Depth and
Semi-Recuperator Benches,**

And also furnish and build

Our Own Styles Semi-Recuperator Furnaces
for the use of Coal or Coke as fuel.

THOS. SMITH, Prest.

AUGUST LAMBLA, Vice-Prest. & Supt.

BALTIMORE**RETORT & FIRE BRICK CO.**

MANUFACTORY AT

LOCUST POINT, BALTIMORE, MD.

**Clay Retorts, Blocks & Tiles
FIRE BRICK, FIRE CLAY,
AND FIRE CEMENT.**Red and Buff Ornamental Tiles and Chim-
ney Tops. Drain and Sewer Pipe (from
2 to 30 inches). Baker Oven Tiles
12 x 12 x 2 and 10 x 10 x 2.

WALDO BROS., 88 WATER ST., BOSTON, MASS

Sole Agents the New England States.

Boston Fire Brick Works Manufact-
urers of **Gas Retorts and Settings**

Under the Personal Supervision of MR. GEO. C. HICKS late of Chicago.

Fire Clay Goods of all kinds. Akron Sewer Pipe, Lime, Cement, etc. Agts. for the Arc Gas Lamp & Governing Gas Burners.
Send for Circulars and Prices to**FISKE, COLEMAN & CO., Managers, No. 62 Congress Street, Boston, Mass.**

FRED. BREDEL, C. E.,

Contractor for the Complete Erection and Equipment of Gas Works.

Sole Proprietor of the KLOENNE PATENTS for North America.

Gas Condensing and Purifying Machine.

Doing all the Work Between Exhauster & Oxide Purifier.

No Condensers Required.

No Naphthaline or Pitch is Formed.

HIGHER CANDLE POWER.

Tar & Ammonia Washers

WATER GAS WASHERS.

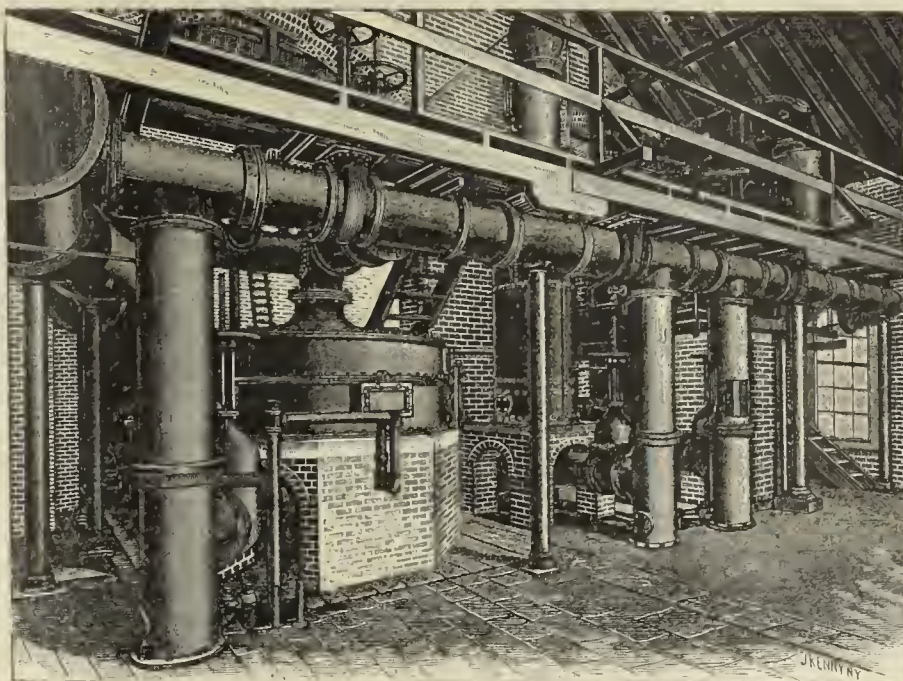

Purifying Machine erected at Cleveland Gas Works, No. 2. Capacity, 1,250,000 Cu. Ft.

RECUPERATIVE FURNACES.

Adapted to Retort Houses With or Without Stage Level.

Over 1,400 Retorts Now in Use in America.

Inclined Retort Benches.

Refers, by permission, to Mr. Eugene Vanderpool, Newark, N. J., and Mr. E. G. Cowdery, Milwaukee, Wis. For further information address

FRED. BREDEL,

No. 208 East Seventeenth Street, - - - - New York City.

FLEMMING'S Generator-Gas Furnace

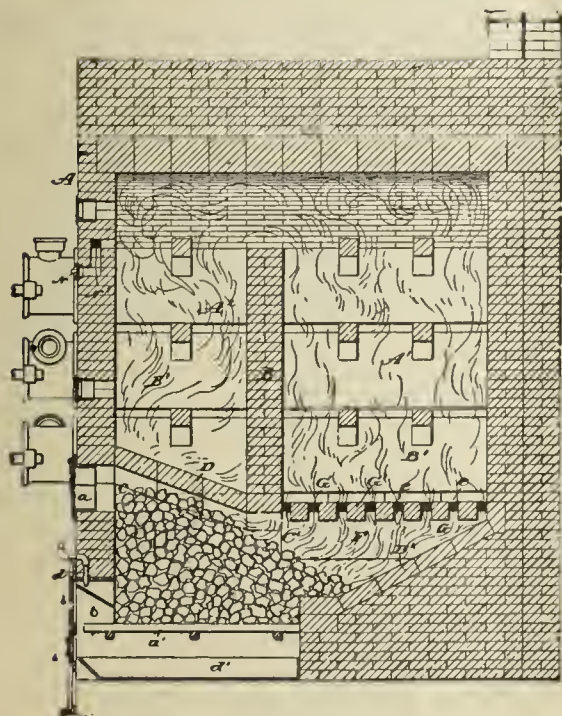

Materials furnished and Benches erected by

J. H. GAUTIER & CO., - Jersey City, N. J.

Address as above, or D. D. FLEMMING, Jersey City, N. J.

HENRY MAURER & SON,

(ESTABLISHED 1856.)

EXCELSIOR FIRE BRICK & CLAY RETORT WORKS

WORKS, Perth Amboy, N. J.

OFFICE, 418 to 422 East 23d St., N. Y.

Clay Gas Retorts, BENCH SETTINGS, Fire Brick, Tiles, Etc.

PATENTS.

FRANKLIN H. HOUGH

Solicitor of American & Foreign Patents.

925 F. ST., WASHINGTON, D. C.

(NEAR U. S. PATENT OFFICE.)

Personal attention given to the preparation and prosecution of applications for Letters Patent. All business before the U. S. Patent Office attended to for moderate fees. No Agency in the United States possesses superior facilities for obtaining Patents, or for ascertaining the patentability of inventions. Copies of patents furnished for 25 cents each. Correspondence solicited.

GREENOUGH'S

"DIGEST OF GAS LAW."

Price, \$5.00.

This is a valuable and important work, a copy of which should be in the possession of every gas company in the country, whether large or small. As a book of reference it will be found invaluable. It is the only work of the kind which has ever been published in this country, and is most complete. Handsomely bound. Orders may be sent to

A. M. CALLENDER & CO.,

42 Pine Street, N. Y.

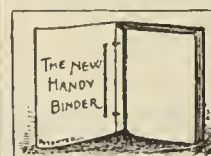

THE NEW HANDY BINDER.

This article may be described as elegant in appearance, strong, durable, and possessing many special qualities of its own. It allows the opening of the pages perfectly flat, whether one or several numbers are in the binder. Any number can be taken out and replaced without disturbing the others. The papers are not mutilated for subsequent binding in permanent form. The binder is supplied with gilt side file, and is an ornament to any desk or reading table. The JOURNAL, filed in the Handy Binder, becomes a volume of great value, always convenient for instant reference. Handy Binder, Postage paid, \$1 00.

A. M. CALLENDER & CO., 42 Pine St., N. Y.

NEWBIGGING'S HANDBOOK FOR GAS ENGINEERS AND MANAGERS.

The present (the fifth) edition marks an important advance on those that have gone before. and much of it has been rewritten and otherwise improved. Price, cloth, \$6.

Considerable additions have been made to the text, A. M. CALLENDER & CO., 42 Pine St., N. Y.

DAVIS & FARNUM MFG. CO.,

WALTHAM, MASS.

PRINCIPAL OFFICE AND WORKS, Waltham, Mass.

BOSTON OFFICE, Room 55, Mason Building, 70 Kilby Street.

SINGLE, DOUBLE,
AND
TRIPLE LIFT

Gas holders.

OF ANY CAPACITY.

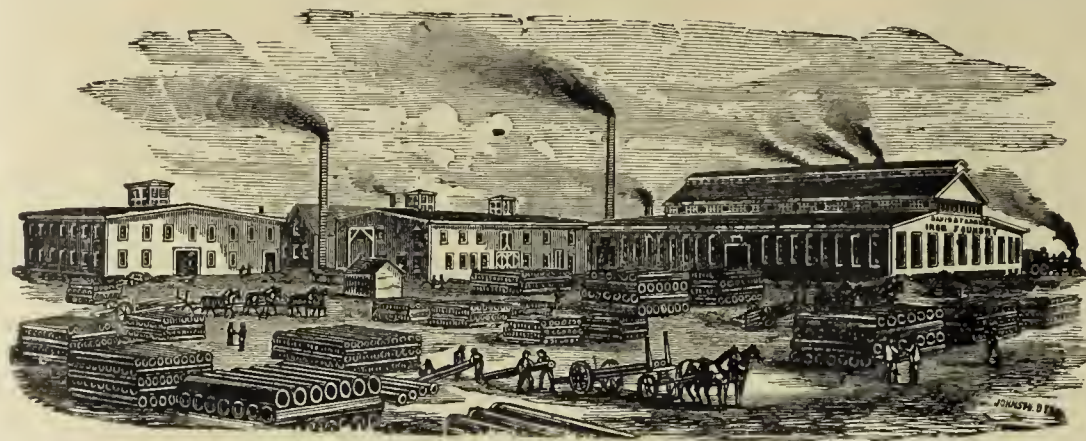

TUBULAR, PIPE,
AND
SINUOUS FRICTION

Condensers.

OF ALL SIZES.

IRON ROOF FRAMES AND FLOORS.

Purifying Boxes, Center Seal or Valve Connections, Bench Work.

Reversible Lime Trays.

SELF-SEALING AND PRESSED STEEL MOUTHPIECE LIDS.

Coke Barrows, Coal Wagons, and all Apparatus Requisite for a Complete Gas Plant.

— ALSO —

Gas and Water Pipe, Flanged Pipe,

Sugar House Work, and Special Castings of all Descriptions.

Established 1881.

Incorporated 1881.

KERR MURRAY MFG. CO.,

FORT WAYNE, IND.

Those who are in need of

Holdings or Gas Works Apparatus of any Description,

AND OF THE LATEST IMPROVEMENTS,

will find it to their interest to

GET AN ESTIMATE FROM US

before placing their order.

As we make a Specialty of this Class of Work, and are Practical Builders and Manufacturers of same,

with our long years of experience in the business,

WE CAN GUARANTEE YOU SATISFACTION.

Estimates, Plans and Specifications Furnished on Application.

BARTLETT, HAYWARD & CO.

Baltimore, Md.

Triple Double, & Single-Lift
GASHOLDERS.

Iron Holder Tanks.

ROOF FRAMES.

Cirders.

BEAMS.

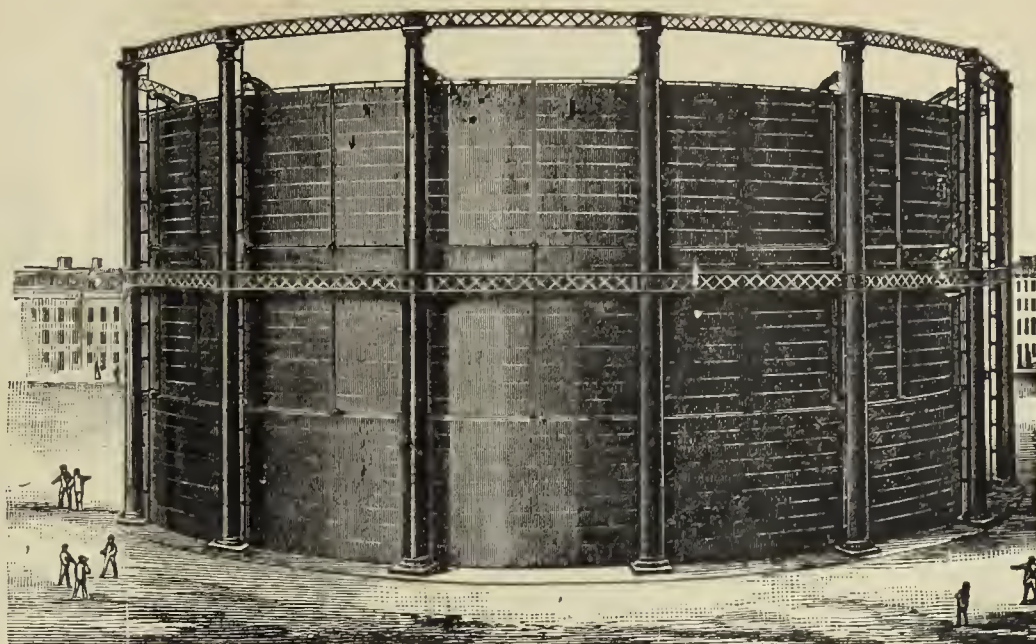

PURIFIERS.

CONDENSERS.

Scrubbers.

BENCH CASTINGS.

OIL STORAGE TANKS.

Boilers.

The Wilkinson Water Gas Process.

THIRTY-CANDLE, NON-CONDENSABLE, FIXED GAS. THE MOST SUCCESSFUL GAS PROCESS IN OPERATION.

Munich Regenerative Furnace, System Drs. Schilling & Bunte.

HAZELTON BOILERS.

Gas Works Designed and Constructed.

Pascal Iron Works. ESTABLISHED 1821. Delaware Iron Works.

MORRIS, TASKER & CO.,

INCORPORATED.

OFFICE, 224 SOUTH THIRD STREET, - - PHILADELPHIA, PA.

CONTRACTORS, BUILDERS, AND MANUFACTURERS OF

Gas, Water & Sugar Works

Bench Castings.

Condensers.

Scrubbers.

Purifiers.

Hyd. Carriages.

Iron Floors,

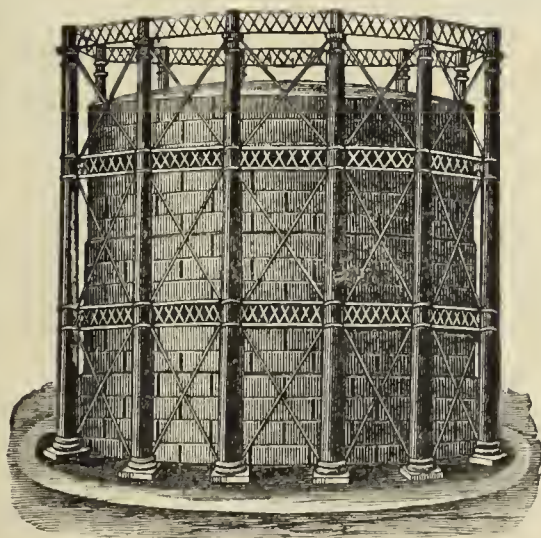

Iron Roofs.

Street Stops,

Valves, etc.

Stand-Pipes.

Water & Oil

Tanks, all Sizes.

Single, Double, and Triple-Lift Gas Holders.

SELF-SEALING RETORT LIDS. STAMPED STEEL RETORT LIDS.

Locomotive Water Columns, Filters, etc. Boiler Tubes, Wrought Iron Pipe & Fittings

Plans, Specifications and Estimates for all kinds of Machinery furnished on application.

Foundries & Works,
MILLVILLE, FLORENCE,
and CAMDEN, N. J.

R. D. WOOD & CO.,

Engineers,
Iron Founders,
and
Machinists.

400 Chestnut St., PHILADELPHIA, PA.

MANUFACTURERS OF

CAST IRON PIPE,

Gas Holders,

SINGLE, DOUBLE, AND TRIPLE LIFTS, WITH
OR WITHOUT WROUGHT IRON
OR STEEL TANKS.

PURIFIERS, CONDENSERS.

Scrubbers.

BENCH WORK.

Iron Floors and Roofs, Plate Girders.

Heavy Loam Castings.

HYDRAULIC WORK.

Lamp Posts, Valves, Etc.

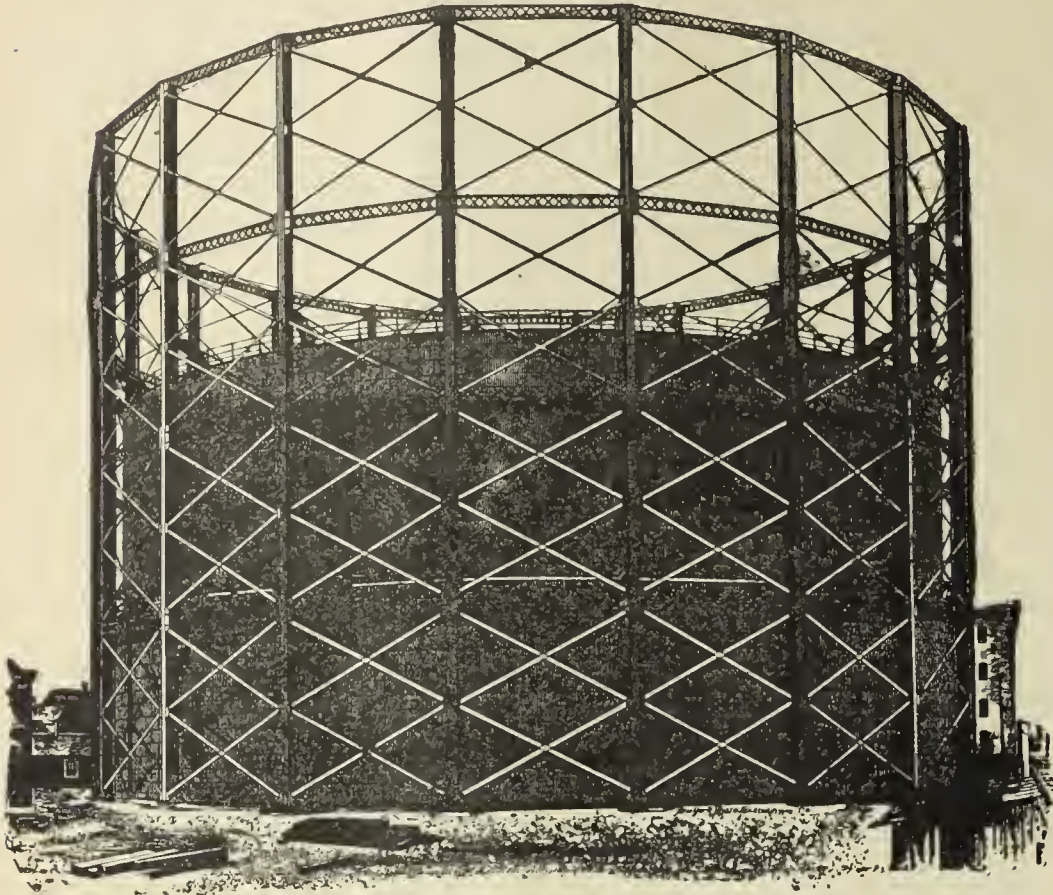

SMITH & SAYRE MFG. COMPANY,

G. G. PORTER, Prest.

245 Broadway, N. Y.

CHAS. W. ISBELL, Sec'y.

Machinery & Apparatus for Gas Works

Drawings, Plans, and Estimates. Furnished for the Improvement, Extension, or Alteration of Gas Works, or for the Construction of New Works.

Mackenzie's Patent Rotary and Steam Jet Gas Exhausters, Governors, Compensators, Condensers, Washers, Scrubbers. Isbell's Patent Automatic Street Pressure Governor, Gas and Water Valves, Hydraulic Main Dip Regulator, Bench Castings, etc. Purifying Boxes and "Standard" Scrubbers. Isbell's Patent Self-Sealing Retort Doors.

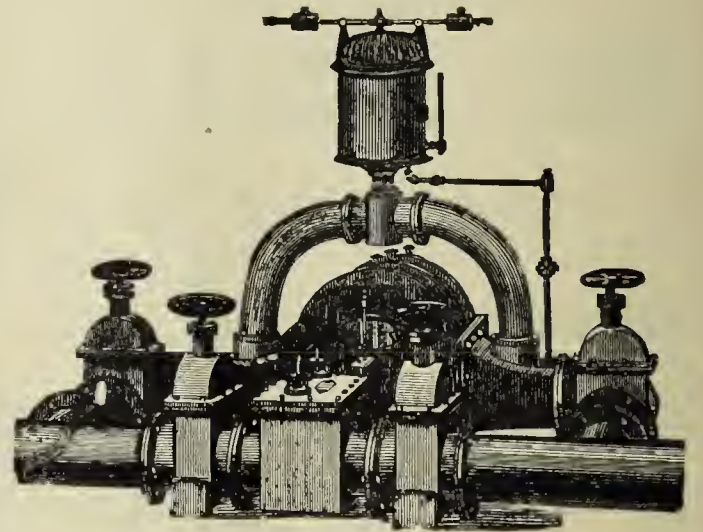

THE BRENNER SELF-SEALING RETORT DOOR.

Simple, Strong, and Durable.

CLOSES ABSOLUTELY TIGHT & IS LOCKED BY A CAM LEVER. ALL NECESSARY ADJUSTMENT FOR WEAR PROVIDED.

BUILT BY

SMITH & SAYRE MFG. CO.,

No. 245 Broadway, - - - New York City.

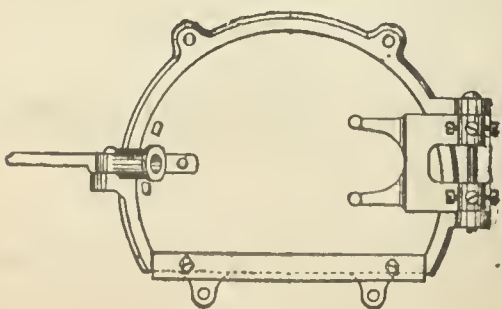

Brenner Self-Sealing Retort Door.

WILLIAM B. LUNDIE, Superintendent of the 42d Street Station of the Consolidated Gas Company, of New York, writes, under date of Jan. 4, 1889:

"We have 320 Brenner Self-Sealing Lids in use at this Station, built by the Smith & Sayre Mfg. Co. They require very little attention, and are the best of the kind that I have seen, giving entire satisfaction."

GAS WORKS APPARATUS AND CONSTRUCTION.

GAS WORKS APPARATUS AND CONSTRUCTION.

JAMES R. FLOYD & SONS,

(SUCCESSORS TO HERRING & FLOYD)

Oregon Iron Works,

W. 20th & 21st. Sts., bet. 10th & 11th Aves.,

NEW YORK CITY.

Engineers and Contractors

FOR THE

CONSTRUCTION OF GAS WORKS.

MANUFACTURERS OF

All Kinds of Castings and General Ironwork

FOR

GAS APPARATUS.

Bench Castings, Regenerative and Half Regenerative Furnace Castings.

Condensers, Scrubbers, Purifiers, Street Drips and Connections,

Valves,

Hydraulic Hoisting Purifier Carriage, Self-Sealing Retort Lids, Improved Valve Stand and Indicator,

Seller's Cement.

Plans, Specifications, and Estimates furnished for Construction of New or Alteration of Old Works.

CONTINENTAL IRON WORKS.

THOS. F. ROWLAND, Prest.

WARREN E. HILL and CHAS. H. CORBETT, V-Prests.

THOS. F. ROWLAND, JR., Sec. & Tr

P. O. Station G., BROOKLYN, N. Y.

ENGINEERS AND MANUFACTURERS OF

Gas Holders

CONDENSERS, SCRUBBERS, VALVES,

PURIFIERS, SELF-SEALING RETORT LIDS

Hydraulic Mains,

And all other articles connected with the manufacture and distribution of Gas.



H. RANSHAW, Prest. & Mangr.

WM. STACEY, Vice-Prest.

T. H. BIRCH, Asst. Mangr.

R. J. TARVIN, Sec. & Treas.

STACEY MFG. CO.,

MANUFACTURERS OF

Single and Telescopic Gasholders,

IRON ROOFS, BRIDGES, LAMP POSTS,

Water and Oil Tanks, Coal Elevator Cars,

COKE CRUSHERS, BENCH CASTINGS,

And all kinds of Wrought and Cast Iron Work used in the erection of Coal and Oil Gas Works Rolling Mill Machinery and Heavy Castings a Specialty.

Foundry:

33, 35, 37 & 39 Mill Street.

Wrought Iron Works:

16, 18, 20, 22, 24 & 26 Ramsey Street:

Cincinnati, Ohio.

Bouton Foundry Co.,

FOUNDERS AND MACHINISTS,

CHICAGO, ILL.

Gas Works Apparatus,

PURIFIERS, CONDENSERS,

Bench Work

SPECIALS, LAMP POSTS,

SCRUBBERS,

Iron Roofs and Floors.

Plans and Estimates furnished for new works or extensions of old works.

1842. **DEILY & FOWLER,** 1890.

Laurel Iron Works.

Address, No. 39 Laurel Street, Philadelphia, Pa.

BUILDERS OF

GASHOLDERS,

Single and Telescopic.

Holders Built 1884 to 1888, Inclusive:

- | | | | | |
|----------------------------|-----------------------------|---------------------------|--------------------------|------------------------|
| Newport, R. I. | Long Island City, N. Y. | Port Chester, N. Y. | Malden, Mass. | West Chester, Pa. (2d) |
| Portland, Oregon. | Macon, Ga. | New Rochelle, N. Y. | Paducah, Ky. | Lancaster, Pa. (3d) |
| Allegheny, Pa. (2d.) | York, Pa. | Salem, N. J. (3d) | Norwich, Conn. | Facony, Pa. (two) |
| Atlanta, Ga. (2d.) | Chester, Pa. | Omaha, Neb. (2d) | Seattle, W. T. | Mount Vernon, N. Y. |
| N.Y. City (Central Gas Co) | Hazleton, Pa. (2d.) | Lynn, Mass. (2d) | San Diego, Cal. | Binghamton, N. Y. |
| Lynchburg, Va. (2d.) | Stateo Island, N. Y. | Little Rock, Ark. | Northern Gas Lt. Co., of | Concord, N. H. |
| Saylesville, R. I. | Saugerties, N. Y. | Irvington, N. Y. | New York N. Y. | Dover, Del. (2d) |
| Rondout, N. Y. | Clinton, Mass. (Lan. Mills) | South Boston, Mass. | Westerly, R. I. | Calais, Me. |
| Atlantic City, N. J. | Chattanooga, Tenn. | Rye, N. Y. (2) | Willimantic, Conn | New London, Conn. (2d) |
| Augusta, Ga. | Galveston, Texas. (3d.) | Woodstock, Ont. | Montclair, N. J. | West Chester, N. Y. |
| Waltham, Mass. (2) | Omaha, Neb. | Malden, Mass. | Attleboro, Mass. | Bay Shore, L. I. |
| Mahanoy City, Pa. | Fort Plain, N. Y. | Staten Island, N. Y. (2d) | Santa Cruz, Cal. | Washington, D. C. |
| New Castle, Pa. | Brunswick, Ga. | Woodstock, Ont. | Erie, Pa. (2d) | |

WM. HENRY WHITE,

No. 32 Pine Street, - - - New York City.

ENGINEER AND CONTRACTOR FOR THE

ERECTION AND EXTENSION OF

GAS, WATER, AND ELECTRIC LIGHT WORKS.

Correspondence with Gas Companies contemplating extending or improving their Plants respectfully invited.

Plans and Estimates Furnished.

GAS COALS.

CANNEL COALS.

GAS ENRICHERS.

JAMES D. PERKINS. **PERKINS & CO.,** F. SEAVERNES.
 228 & 229 Produce Exchange, New York.
 Cable Address, "PERKINS, NEW YORK." Post Office Box 3695, New York.

GENERAL SALES AGENTS FOR

The Youghioghenny River Coal Company's

OCEAN MINE YOUGHIOGHENY GAS COAL.

HON. W. L. SCOTT, Prest.

M. H. TAYLOR, Vice-Prest.

This Colliery is located at SCOTT HAVEN, PA., in the center of the Youghioghenny Gas Coal District, and produces the **ONLY RELIABLE YOUGHIOGHENY COAL** for gas purposes. (See Map on p. 87 of this JOURNAL, Feb. 16, '85.)

POINTS OF SHIPMENT,

Locust Point, BALTIMORE.

Pier No. 62, PHILADELPHIA.

Also, **SOLE AGENTS** for the

BRECKENRIDGE CANNEL,

OF KENTUCKY.

Within the past two years we have delivered this Cannel to over **ONE HUNDRED COMPANIES IN THIRTY-THREE DIFFERENT STATES**, and it is now in use in some of the large Gas Works

On the Continent and in South America,

where it successfully competes with the Australian Shale. It is the **ONLY AMERICAN GAS CANNEL** of sufficiently high grade to warrant **EXPORTATION TO EUROPE AND SOUTH AMERICA**, and it is the only economical substitute for **OIL OR NAPHTHA**. **ONE GROSS TON** will produce

10,000 Cubic Feet of 75 Candle Gas,	} equal to {	750,000 Candle Feet of Gas, and 26 Bushels of merchantable Coke weighing 900 Pounds
or 12,500 " " 60 " "		
or 15,000 " " 50 " "		

This is the **ONLY GAS CANNEL** that will produce a **REALLY MERCHANTABLE COKE**. It can be delivered in parcels of one carload or more to any point in the United States or Canada. Cargo shipments of any size required can be made from **NEW YORK, PHILADELPHIA, BALTIMORE, or NEWPORT NEWS**. Samples will be sent and particulars of price, etc., forwarded upon application to above address.

JAMES & WILLIAM WOOD,

Gas and Cannel Coal Contractors,

No. 40 St. Enoch Sq., Glasgow. No. 2 Talbot Court, London.

Proprietors of the **BATHVILLE COLLIERIES** (which produce the celebrated **BOGHEAD CANNEL**), Shields, Shieldmuir, Drumpeller, and other Collieries. This Firm offer

STANDARD CANNELS,

Unequaled as Gas Enrichers.

Analyses, prices, and all further information furnished on application to

Agency for U. S., Room 70, Nos. 2 & 4 Stone St., N.Y. City.

The Standard Oil Company,

REFINERS OF

NAPHTHA AND GASOLINES.

ALSO MANUFACTURERS OF

A Special Grade of Naptha for Gas Companies

FOR ENRICHING COAL GAS.

Correspondence solicited.

No. 43 Euclid Avenue, Cleveland, Ohio.

To Gas Companies.We make to order **CAP BURNERS** to burn any amount under a stated pressure. Send for samples.Also, **SERVICE CLEANERS, DRIP PUMPS, and STREET MAIN PROVING APPARATUS.****O. A. GEFRORER,**

248 N 8th Street, Phila., Pa.

COKE CRUSHERS.

GAS COALS.

GAS COALS.

Newburgh Orrel Coal and Coke Co.

MINERS AND SHIPPERS OF

STEAM, SMITHING, AND GAS COALS,
Foundry and Crushed Coke.

Home Office, 33 S. Gay Street, Baltimore, Md.

J. HARRY LEE, President.

Shipping Wharves, Locust Point, Baltimore.

The Despard Gas Coal Co.,

MINERS AND SHIPPERS OF

DESPARD GAS COAL,

AND MANUFACTURERS OF

COKE.

MINES, Clarksburg, Harrison Co., W. Va.

WHARVES, Locust Point, Baltimore, Md.

OFFICE, 225 E. German St., " "

ROUSSEL & HICKS, } AGENTS. } BANGS & HORTON,
71 Broadway, N. Y. } 60 Congress St., Boston.

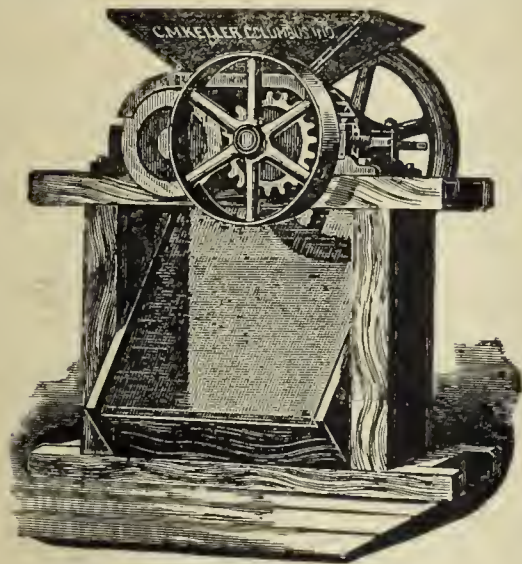

Keller's Adjustable Coke Crusher.

SIMPLE, STRONG, AND DURABLE.

C. M. Keller, Sec. & Supt. Gas Lt. & Coke Co. Columbus, Ind.

Correspondence Solicited.

King's Treatise on Coal Gas.

The most complete work on Coal Gas ever published

Three Vols. Bound, \$30.

BOOKS.

DISTILLATION OF COAL TAR AND AMMONIACAL LIQUOR.

By GEORGE LUNGE. Price \$12.50.

A TREATISE ON THE COMPARATIVE COMMERCIAL VALUES OF GAS COALS AND CANNELS.

By DAVID A. GRAHAM. 8vo., Cloth. Price \$3.

Orders for these books may be sent to this office.

A. M. CALLENDER & CO.,

42 PINE ST., N. Y. CITY

THE PENN GAS COAL CO.

OFFER THEIR

Coal, Carefully Screened & Prepared for Gas Purposes.

Their Property is located in the Youghiogheny Coal Basin, near Irwin and Penn Stations on the Pennsylvania Railroad, and on the Youghiogheny River.

Principal Office:

209 SOUTH THIRD STREET, PHILA., PA.

Points of Shipment:

Pennsylvania Railroad Piers; Greenwich Wharves, Delaware River; Pier No. 1 (Lower Side), South Amboy, N. J.

Chesapeake & Ohio Railway Coal Agency,

FOR THE SALE OF THE

Superior Kanawha Gas Coals, Cannelton Cannel, Also, SPLINT AND STEAM COALS,

From the Kanawha and New River Regions, on the line of the Chesapeake & Ohio R'way.

C. B. ORCUTT, General Agent, - - No. 1 Broadway (Room 217) New York City.

FRANCIS H. JACKSON, Prest.

EDMUND H. MCCULLOUGH, V.-Prest.

CHAS. F. GODSHALL, Treas.

H. C. ADAMS, Sec.

THE WESTMORELAND COAL CO.

Chartered 1854.

Mines situated on the Pennsylvania and the Baltimore and Ohio Railroads, in Westmoreland County, Penn.

POINTS OF SHIPMENT:

PHILADELPHIA, BALTIMORE, SOUTH AMBOY, N. J., WATKINS (SENECA LAKE), N. Y.

Since the commencement of operations by this Company its well-known Coal has been largely used by the Gas Companies of New England and the Middle States, and its character is established as having no superior in gas-giving qualities, and in freedom from sulphur and other impurities.

Principal Office, 224 South 3d St., Phila., Pa.

The American Gas Engineer and Superintendent's Handbook.

BY WILLIAM MOONEY.

Consisting of Rules, Reference Tables, and Original Matter Pertaining to the Manufacture, Manipulation, and Distribution of Illuminating Gas.

350 Pages, Full Gilt Morocco.

\$3.00.

A. M. CALLENDER & CO., 42 Pine St., N. Y.

JOHN J. GRIFFIN & CO.,

Nos. 1513, 1515, 1517 & 1519 Race Street, PHILADELPHIA.

52 Dey St., NEW YORK.

75 N. Clinton St., (FRED. R. PERSONS, Mangr.) CHICAGO.

MANUFACTURERS OF

METERS FOR MEASURING GAS

IN ANY VOLUME.

Provers, Gauges, Registers, Etc., Etc.

EXPERIMENTAL APPARATUS FOR QUANTITATIVE AND QUALITATIVE ANALYSIS.

Careful and Prompt Attention paid to Repairing of all kinds of Meters and Apparatus.

Estimates Cheerfully Furnished.



NATHANIEL TUFTS,

No. 153 Franklin Street, Boston, Mass.,

MANUFACTURER OF

DRY GAS METERS.

Station Meters of any Capacity.

Test and Experimental Meters, Pressure Registers, Pressure Gauges, Pressure and Vacuum Gauges.

METER PROVERS, PHOTOMETERS, STREET LANTERNS, ETC., ETC.

Patent Cluster Lanterns for Street Illumination.



Dry Gas Meters.

With 40 years' experience and the best facilities for manufacturing, is enabled to furnish reliable work and answer orders promptly.

HAROLD J. BELL.

BELL & JONES,

S. LEWIS JONES.

No. 12 North Ninth Street, Philadelphia, Pa.

Works at Royersford, Pa.

MANUFACTURERS OF

GAS METERS, STATION AND EXPERIMENTAL METERS,

Meter Provers, Pressure Gauges, and All Other Gas Appliances in Our Line.

WE REPAIR ALL KINDS AND MAKES OF METERS, AND THE WORK GUARANTEED.

High Pressure Meters for Natural Gas, in Iron Cases, guaranteed to stand 300 lbs. Pressure.

Gas Cooking and Heating Stoves, Hot Plates, Cake Griddles, Waffle Bakers, Boiling Stoves, Laundry and Tailors' Iron Heaters. Hotel and Cafe Ranges a Specialty.

Correspondence Solicited.

Estimates Furnished.

A. HARRIS.

E. L. HARRIS.

J. A. HARRIS.

Established 1849.

HARRIS BROS. & CO.,

Twelfth and Brown Streets, Philadelphia.

Manufacturers of Wet and Dry Gas Meters,

STATION METERS, METER PROVERS,

EXPERIMENTAL METERS, SHOW OR GLAZED METERS,

Pressure and Vacuum Registers, Gauges, Photometers, Drip and Bell Pumps, Etc., Etc.

PROMPT ATTENTION GIVEN TO ALL ORDERS. METERS THOROUGHLY REPAIRED. ESTIMATES FURNISHED FOR STATION METERS OF ALL SIZES. CORRESPONDENCE SOLICITED.

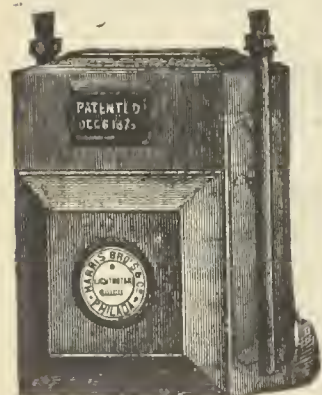

GAS METERS.

GAS METERS.

GAS METERS.

GEO. J. MCGOURKEY, Prest.

WM. H. MCFADDEN, Vice-Prest. (Phila.)

WM. N. MILSTED, Gen. Supt. and Treas. (New York).

WM. H. DOWN, Sec.

THE AMERICAN METER CO.

Established 1834.

Incorporated 1863.

WET AND DRY GAS METERS.

PRESSURE REGISTERS.

METER PROVERS.

STATION METERS.

PRESSURE & VACUUM REGISTERS.

PORTABLE TEST METERS.

EXHAUSTER GOVERNORS.

PRESSURE & VACUUM GAUGES.

EXPERIMENTAL METERS.

DRY CENTER VALVES.

CRESSON GAS REGULATORS.

AMMONIA TEST METERS.

GOVERNORS FOR GAS WORKS.

MARSLAND WATER METERS.

BAR & JET PHOTOMETERS.

Manufactories:

512 West 22d St., N. Y.

Arch & 22d Sts., Phila.

GAS STOVES.

SUGG'S "STANDARD" ARGAND BURNERS,

SUGG'S ILLUMINATING POWER METER,

Wet Meters, with Lizar's "Invariable Measuring" Drum.

Agencies:

177 Elm Street, Cincinnati.

244 & 246 N. Wells Street, Chicago.

810 North Second Street, St. Louis.

222 Sutter Street, San Francisco.

HELME & McILHENNY,

(Established 1848.)

GAS METER MANUFACTURERS,

Nos. 1339 to 1349 Cherry Street, Philadelphia, Pa.,

WET AND DRY GAS METERS. STATION METERS, EXPERIMENTAL METERS, METER PROVERS,

Center Seals, Pressure Registers, Governors, Indicators, Photometers, and all other kinds of Apparatus for use in Gas Works.

FOULIS' PATENT STATION AND DISTRICT GOVERNORS.

REPAIRING DEPARTMENT.—We employ a special force of skilled workmen repairing meters of all makers.

WM. WALLACE GOODWIN, President and Treasurer.

E. STEIN, Vice-President.

H. B. GOODWIN, Secretary and Superintendent.

THE GOODWIN GAS STOVE AND METER CO.,

Successors to W. W. GOODWIN & CO.

1012, 1014 and 1016 Filbert St., Phila., Pa.

113 Chambers St., New York City.

76 Dearborn, St., Chicago, Ills

WALDO BROTHERS, Agents, 88 Water Streets, Boston, Mass.

MANUFACTURERS OF

DRY AND WET GAS METERS,

Station Meters (square, cylindrical, or in staves), Glazed Meters, King's and Sugg's Experimental Meters, Lamp Post Meters, etc., etc. Meter

Provers (sizes 2, 5, and 10 feet). Pressure Gauges of all kinds, Pressure Registers, Pressure and Vacuum Registers, Pressure Indicators

(sizes 4, 6, and 9 inch), King's Pressure and Vacuum Gauges, Dry and Wet Center Seals, Dry and Wet Governors, Exhauster

Governors, Photometers of all descriptions. Letheby's Sulphur and Ammonia Test Apparatus complete. Also, Testing

and Chemical Apparatus of all kinds, and of the most perfect description, for all purposes relating to Gas.

Manufacturers of the "SUN DIAL" GAS STOVES, for Cooking and Heating.

Goodwin's Improved Lowe's Jet Photometer.

Agents for Bray's Patent Gas Burners and Lanterns.

Special attention to Repairs of Meters and all Apparatus connected with the business. All work guaranteed first-class in every particular. Orders filled promptly.

G. B. EDWARDS, Manager, New York.

S. S. STRATTON, Manager, Chicago.

D. McDONALD & CO.,

GAS METER MANUFACTURERS.

(Established 1854.)

51 Lancaster St., Albany, N. Y.

34 & 36 West Monroe St., Chicago, Ill.

STATION METERS, EXPERIMENTAL METERS, METER PROVERS, PRESSURE & VACUUM REGISTERS, PRESSURE GAUGES, ETC.

Also STAR GAS STOVES, RANGES, and HEATING STOVES.

We use only the very best materials, and employ the most skilled labor, and by our long experience (36 years) and personal supervision of every detail, we feel justified in assuring the public that our goods will give perfect satisfaction. Every Meter emanating from our establishment will bear the State Inspector's BADGE, and will be fully warranted by us. Our Annual and Calendar will be sent to Gas Companies upon application.

GAS INTO POWER,

BY THE

OTTO GAS ENGINE.

GAS POWER.—A Source of Revenue to Gas Companies ready to engage in Electric Lighting, building of Water Works, Electric Street Railways, etc.

Coal for producing Gas is less in amount than that for producing Steam, both being measured on an equal amount of work performed. And, further, with Gas,

50 to 90 per Cent. of Value of Coal is Returned

by sale of Coke and Tar, according to the market value of these products.

Labor for handling fuel is reduced, by its becoming centralized and confined to the gas house, and frequently has not increased after the addition of a power station.

With Gas Power, cost of fuel is strictly limited to the time of use.

MANY VALUABLE
AND RECENT
IMPROVEMENTS.

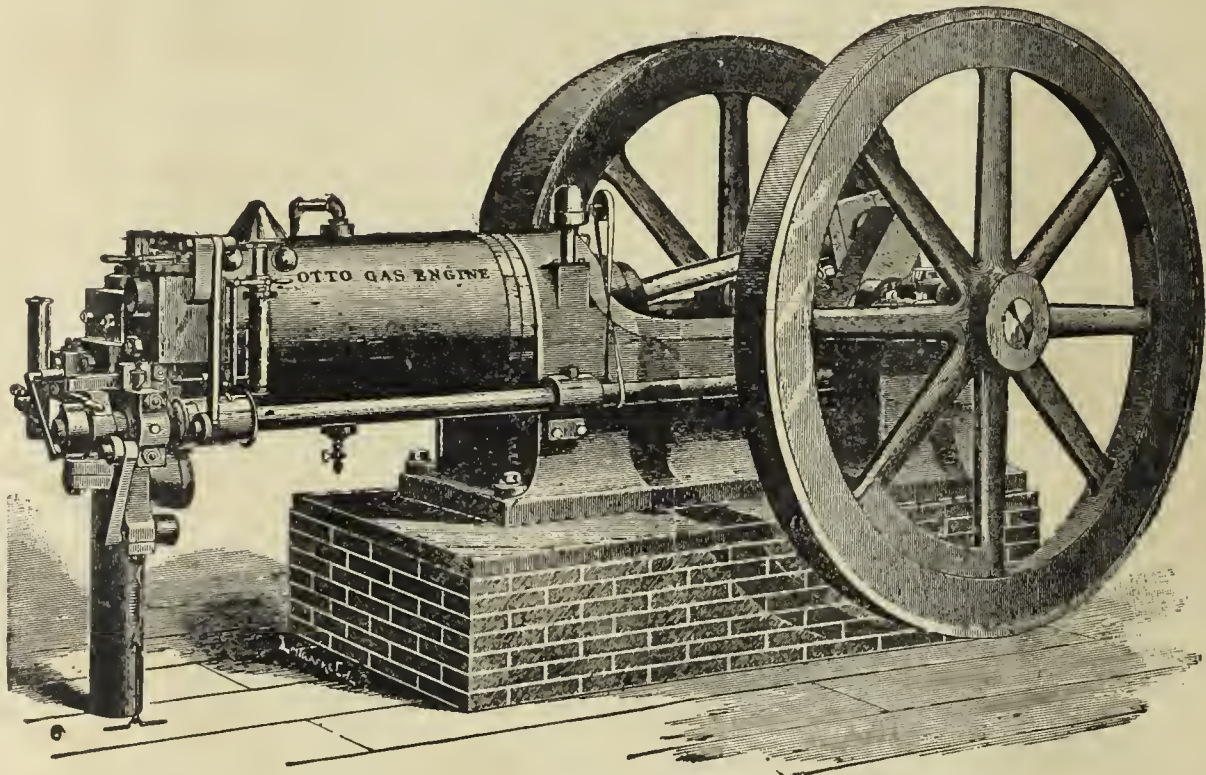

SIZES,
1-3 to 100
HORSE POWER.

Wherever Gas Companies tried Gas Power with Steam Power together in one Station, the use of Steam was subsequently abandoned or restricted, and Gas Power made to take its place.

Where Gas Companies adopt Gas Power for Electric Plants, Water Works, Sewerage, etc., they not only choose the most economical power for their use, but secure to themselves the numerous advantages of increased production, without increase of expense, and benefit thereby their entire manufacture. They induce consumers, by their example, to abandon Steam for Gas Power, and, by establishing special rates, make

Gas Power the Leading Power of To-Day,
AND SOLVE AT ONCE THE QUESTION OF FUEL GAS.

“Otto Gas Engine Works,”

SCHLEICHER, SCHUMM & CO.,

151 Monroe St. (Kent Building), Chicago.

33d & Walnut Sts., Phila.

NEW YORK AGENCY, 18 VESEY STREET.

THE AMERICAN

GAS LIGHT JOURNAL

RODMAN & KENNY, N.Y.

PUBLISHING OFFICE No. 42 PINE STREET

DEVOTED TO THE INTERESTS OF ILLUMINATION, VENTILATION, WATER SUPPLY AND DISTRIBUTION, & GENERAL SCIENCE.

VOLUME LII.—No. 25.
Whole No. 785.

NEW YORK, MONDAY, JUNE 23, 1890.

{ \$3 PER ANNUM,
IN ADVANCE.

A. M. CALLENDER & CO., Proprietors. C. E. SANDERSON, Manager.
JOS. R. THOMAS, C.E., Editor. T. J. CUNNINGHAM, Asst. Editor.

ENTERED AT THE POST OFFICE AT NEW YORK, N. Y.
AS SECOND CLASS MATTER.

Published on each Monday of the year, at No. 42 Pine Street, N. Y.

Terms of Subscription, Including Postage.—For the United States and Canada, \$3 per annum. European countries, \$4.50 (19 shillings—22½ francs). All payments to be made in advance. Single copies, 10 cents.

Remittances should be made either by post-office order, express money order, registered letter, or bank draft on New York, payable to the order of A. M. Callender & Co.

Collections are invariably made directly from this office, for subscriptions, advertisements, etc. We have agents to solicit the same, but they are not authorized to receipt for money.

Correspondence.—Wishing to make this JOURNAL a gazette of intelligent discussion to those of our readers who may wish to gain or give information on the subjects to which its columns are devoted, correspondence is solicited for publication from all who make the study of those subjects a pleasure or a profession.

The American News Company, Nos. 39 and 41 Chambers street, New York, are agents for this JOURNAL. Newsdealers will send orders to them.

Books.—We will forward by express, at publisher's lowest rates, any book—scientific or otherwise—to any address in the United States or Canada. We would suggest to our patrons that to avoid the risk and expense consequent on sending us the money (we do not send books C.O.D.), that orders for books be sent us through the Purchasing Department of the American Express Company.

CONTENTS.

An Asterisk (*) denotes an illustrated article.

EDITORIALS—

Briefly Told..... 873

Putting the Blame where it Belongs—Dearer Gas for London, England—A Correction—Doings of the Davis & Farnum Mfg. Co.—Consolidated at Kenton, O.

The Market for Gas Securities..... 874

Thirteenth Annual Meeting, Western Gas Association—Official Report, Revised by the Secretary—Continued from Page 846..... 874

Second Day, Morning Session: Gas Companies' Accounts—Report of Committee, by Mr. Geo. G. Ramsdell—Discussion. Afternoon Session: By-Products of Experience, by Mr. Allen R. Foote—Discussion.

*Matheson's Patent Lock Joint Pipe..... 881

Flames..... 881

The Gas Light and Coke Company and their Men..... 881

Another Loomis Patent in England..... 882

ITEMS OF INTEREST FROM VARIOUS LOCALITIES..... 883

What Mr. Somerville Said—The Florence (Aia.) Company—Annual Convention, American Society of Civil Engineers—Annual Meeting, Williamam, Conn.—Analysis of the Fuel Gas Supplied at Terre Haute, Ind.—A Squabble at Albany, N. Y.—Mr. Fitch Appeals to Inventors—The Practice at Sherman, Tex., in Introducing Gas Stoves—Hints from Louisville, Ky.—Death of Nathaniel Kinsman—Public Lighting, Paterson, N. J.—Killed by Electricity—Annual Meeting, Exeter, N. H.—Annual Meeting, Moncton, N. B.—Valuation of Coal Tar Pitch—And Many Other Items.

The Boiling of Water is not a Guarantee of Purity..... 885

BRIEFLY TOLD.

PUTTING THE BLAME WHERE IT BELONGS.—Residents of this not small or poor city—making one's estimate of its scale of magnitude and riches on the basis of reputed population and known wealth—have often had their attention attracted in forcible manner to the fact that many pipes and conduits lie beneath the pavements of the roadways. We suppose we may be held as speaking by the card in saying that the New Yorker's attention is forcibly called to this underground situation, especially when it is remembered that the local resident is occasionally called upon to dodge through a shower of paving stones, or to rush blindly away from a sandy simoon, or to scurry breathlessly along in an envelopment of steam, or to be startled by a sheet of flame, not infrequently accompanied by a loud report. He may be seated at a restaurant table endeavoring to satisfy his appetite for food; or he may be in Knox's to re-inforce his headgear; or he may be anywhere in the district in which run the pipes of the New York Steam Heating Company; and, if so, he is never safe. All of those disjointed utterances are directly traceable to the wonderful exhibitions that have recently been made of the power of steam in this city, and especially with reference to the square at Broadway and Fulton street. Indeed the only peaceable and safe spot for a pedestrian on or over this now famous crater would seem to be at a point well back in the fronting graveyard that surrounds St. Paul's Church. A week ago last Thursday, at an early hour, and about coeval with the announcement that the "repairs" to the New York Steam Heating Company's pipes, that were in process of carrying on for some days, were completed—Fulton street and Broadway is the district under consideration—the many who are always to be found in the neighborhood of that busy spot were shocked and startled by a loud report and a sheet of flame, the latter springing into the air to a height of perhaps 7 feet, and having a base only limited by the excavation made by the Steam Company's men. The simple history of the uproar and outburst is this. The Steam Company's mains are at a much greater depth than the mains of the Gas Companies—at least two Gas Companies have more than one set of gas pipes in the district—and the steam pipes seem to be always out of repair. The Steam Company, with delightful disregard of anything above or around them, when it comes to the streets at least, digs out its property, repairs its breaks and restores the ground. In the June 12th instance, at least six gas mains were uncovered for several yards, and with scarcely any attempt at suspension. The genial Italians shoveled clods and stones and all that came in the way of their shovels right over, on and about the gas mains with the inevitable result that joints were broken, gas escaped, and the handy naked light completed the conditions necessary for explosion and fire. To make a long story short, the loss occasioned—to the Gas Companies, the steam concern, the subway operators and the adjoining householders—will not fall short of \$100,000, and all because of the infernal recklessness of the Steam Heating Company. On last Wednesday morning the same section of steam pipe gave way, but this time the movement was not so much on the surface as it was "towards centers." The steam simply smashed out a goodly-sized hole in the cellar wall of Knox's building, filling that headgear emporium with a hot mist, and loading the Mack restaurant and kitchen—located in Knox's

cellar—with sand, stones, old iron, etc. In less than an hour the breaks were again repaired, temporarily, that is. While awaiting the next flare-up in that doomed district we may remark now that the public has at last managed to absorb the idea that the Gas Companies are not after all responsible for these disasters, and, stranger still, the daily newspapers agree with the public in holding up the New York Steam Heating Company as the real offender. In fact we should not be at all surprised if the courts, when called upon to say who is at fault, in their trial of the damage suits that are sure to follow, shall seal the opinion that the New York Steam Company is a public nuisance and an unwarrantable trespasser.

DEARER GAS FOR LONDON, ENGLAND.—The proprietors of the Gas Light and Coke Company have notified the public that an increase in gas rates, of 3d. per 1,000 cubic feet for "ordinary" candle power gas, and 4d. per 1,000 cubic feet for cannel gas, has been determined upon. This puts the charges respectively at 2s. 9d. and 3s. 5d. The reasons assigned for this action are: The expiration of advantageous coal contracts and the great increase in labor charges on account of the new arrangement with the workmen.

A CORRECTION.—Mr. John Gimper, of Springfield, Mo., who at the last meeting presented the Western Association with a handsome gavel, desires us to say that the language used by him in making the presentation was as follows:

"Mr. President—A year ago, when, at Cincinnati, our Association was rapped to order with a policeman's club, I was very much mortified that so peaceable and intelligent a body of men as this should be governed with a policeman's club; and I made up my mind then and there that, if spared another year and the means to spare, I should provide the Association with a suitable headblock and gavel. For this purpose you will please observe I have chosen the upper part of a center seal for a headblock; for as the gas flows to and from the center seal, first crude and at last purified, so do our deliberations pass to and from the presiding officer, and are at last sealed by the blow of the gavel. This, Mr. President, therefore becomes an instrument of strength in your hands, and as a member of this Association I take pleasure in presenting these to you, and through you to the Association."

DOINGS OF THE DAVIS & FARNUM MFG. CO.—This bustling Waltham (Mass.) firm reports progress in a right satisfactory manner. Its recent contracts include an 82-foot holder, brick tank and building, for the New Britain (Conn.) Gas Light Company—the holder to have a cup, ready for the reception of a second section, when the latter is needed; a 28-foot holder for the McLean Insane Asylum, at Somerville, Mass., and a very great likelihood for the award of contract for an 80-foot holder at another Eastern point, the bids for which are all in. The 82-foot double lift for Malden (Mass.) and the 78 foot single lift for Gloucester, Mass., are well under way, and the tank for Malden is being rapidly prepared.

CONSOLIDATED AT KENTON, OHIO.—Mr. Thomas Espy, President of the Kenton (O.) Gas and Electric Company, informs us that that Company now owns and operates all of the lighting plants of the city—both electric and gas—and the natural gas plant, formerly owned and operated by the Scioto Natural Gas and Oil Company. The combination has just completed its electric construction (Western Company's type), which has a capacity of about 100 arcs—public and commercial.

The Market for Gas Securities.

The range for city gas shares during the week was unimportant, although a fairly good volume of trade is reported.

Consolidated is at 100½, ex-div., and Mutual moves steadily upward. We quote it at 123 to 125, but we doubt if a good block of the stock could be secured even at an offer of the asking price.

The feature of the week in this vicinity was the sharp rise in Fulton Municipal (Brooklyn), which is quoted at 142 to 145. We might also add that all Brooklyn shares are steady to strong.

Chicago Gas is at 54¼ to 54¾, and we have no doubt whatever that this stock is a purchase at anything under 60.

Bay State common is strong at 87¾. Baltimore Consolidated is rather weaker than before, but well-informed brokers maintain that the shares are easily worth 60.

The Hartford City (Conn.) Gas Light Company has declared a regular semi-annual dividend of 4 per cent., payable July 1. Rumor has it that Mr. George R. Stetson will be chosen to the Presidency of the New Bedford (Mass.) Company. Some inquiry has been made for Laclede, but the rates are very uneven.

[OFFICIAL REPORT—REVISED BY THE SECRETARY—CONTINUED FROM PAGE 846.]

THIRTEENTH ANNUAL MEETING OF THE WESTERN GAS ASSOCIATION.

HELD AT ST. LOUIS, MO., MAY 21, 22 AND 23, 1890.

SECOND DAY—MAY 22—MORNING SESSION.

The President called for the report of the Special Committee on Gas Companies' Accounts, and in response thereto, Mr. Geo. G. Ramsdell, of Vincennes, Ind., submitted and read the following, entitled

GAS COMPANIES' ACCOUNTS—REPORT OF COMMITTEE.

To the President and Members of the Western Gas Association:
Gentlemen—Your Committee, to whom was referred the paper written by Mr. J. D. Thompson, of this city, and read at the Chicago meeting, on the subject of "Gas Companies' Accounts," found in the beginning of its labors considerable difficulty in determining a plan of action. After carefully examining the subject, however, we decided that the amount of labor involved to properly cover the entire theme of gas company's accounts was too great and the topic too important to condense into one report, and the work of preparing such a report more than the Association could profitably exact of one committee; we therefore concluded, the subject being susceptible of subdivision, that to take one branch and thoroughly exhaust it would in its results prove more beneficial and be of more ultimate value to the Association, than to less thoroughly incorporate too much material. This being determined, it became necessary to decide what part of the subject we would embody in our report. In considering this we concluded that, inasmuch as the original idea of the work was particularly to arrive at a uniform system of computing the cost of gas in the holder and distributed, that should form the basis of our work, and we herewith present the result of our labors.

That some uniform system would prove beneficial is apparent—to reach a system meeting the approval of all an impossibility—but your Committee has given the matter its earnest attention, sought every avenue of information that has suggested itself and has formulated a plan, as nearly as lay in its power, meeting the varied requirements. Any form submitted must be flexible in its composition, rigid in its results, equally applicable to large or small works and suitable for the various modes of manufacture. Your Committee has also endeavored to so arrange the form that it may readily be inserted in a complete balance-sheet, if that is considered desirable, or can be carried on separate sheets and conveyed by totals to such a sheet.

The contrasts between the manner of keeping gas accounts of to-day and in the early days of gas manufacture are very marked. Formerly meagre accounts were kept, the prevailing high prices rendering greater economy unnecessary; but as competition and pressure of public opinion became more active, necessity for more rigid scrutiny arose, until now a company whose accounts were not kept in detail would be an anomaly. It is probably true that in an individual case, for its own exclusive use, it would be immaterial what form of computation a company adopted so long as each year the same items regularly entered into it, for this in a measure would afford the desired result—a similar basis year by year for comparison; but while this plan, which may be very perfect or very crude, affords a means of comparison for the individual company it affords no means whatever for comparing one's work with that of another. For example: According to his system of accounting A puts his gas into the holder at a net cost of 25 cents per thousand, while B, similarly situated, computes his cost at 50 cents, yet an analysis of the two methods of accounting may demonstrate that the latter is actually putting his gas into the holder at less cost than the former; therefore, for any reliable comparison it is incumbent to ascertain the exact elements of cost that enter into the computation. The same general features arise in the division of distribution charges and other details that go to make up the expenditures of a gas company, and your committee has found it a perplexing question to satisfactorily determine some of the details of division—or division of details—at the same time keeping in view the complex requirements in other directions.

Our business relations with the public are such as to render us inviting targets for the penetrating shafts of public criticism. One of our many annoyances arising from this lack of uniformity in computing cost is the constant citing of marvelous cheapness of manufacture in some remote city and the patronizing sympathy tendered for our lack of equal ability. We could easily excel as dividend distributors if our cost of gas consisted of coal and lime only and we received a good price for our residuals. Such a system of figuring to us seems too ridiculous

for serious notice ; yet the writer is familiar with a case wherein the local press, in an attack upon the gas company, based its warfare and made its strongest arguments upon the cost of manufacture at a public institution making its own gas, and whose books, upon subsequent investigation, disclosed the fact that the above items only were included in the cost. The pernicious feature of the case rested in the credulous public believing the papers whose disinterested (?) figures "were incontrovertible, being actual figures taken from the books of the institution."

In Massachusetts, owing to the uniformity required by the Gas Commission, each company in the State prepares an annual return upon an established form, so that in that State when the cost of gas is computed each company's computation rests upon exactly the same basis, embraces the same details, its footings forming an equitable aggregate for comparison ; by this uniformity each company can not only reliably ascertain its own progress or the reverse, but precisely how this compares with the results of other companies of similar size and surroundings ; this either incites to greater excellence or causes a strict examination into details where an exhibit exposes inferior management or unsatisfactory results.

We have carefully examined a large number of forms from various companies and desire to acknowledge the courtesies extended to us in this direction, as well as other assistance rendered your Committee in reaching some of our conclusions, entailing as it has a very considerable mass of correspondence. We are especially indebted to Mr. Barker, of the Board of Gas Commissioners of Massachusetts, and Mr. Humphreys, of the United Gas Improvement Company. The forms used in Massachusetts and the one used by the United Gas Improvement Company are each very complete, the latter particularly so, embracing more of detail than your Committee has thought best to recommend, and while the form we present in many points resemble these it is not identical with any of the forms submitted to us.

Before proceeding with the analysis of the form itself we wish to say a few words relative to the reception it will receive. Its success does not rest in the formal vote taken by this Association, but will depend entirely upon individual adoption and operation. As suggested at the outset no plan will be equally acceptable to all, but if a well formulated plan meets the approval of a majority of us would it not be advisable and advantageous on the part of all to give some uniform plan a cordial adoption and a fair trial ; if actual experience demonstrates weakness, or greater wisdom points to improvement, we can still retain the desired uniformity by adopting a desired change and simultaneously entering upon its use. Your Committee does not pretend that its labors have resulted in an absolutely perfect system, but has given you the result of its combined effort ; and if the plan as a whole is not acceptable it can be referred to another committee and thus a perfect system sooner or later secured. Our investigation has taught us that in actual practice there is a desire to avoid some of the items that should rightfully be used in arriving at the cost of gas, thus making the cost apparently less than it really is. If our gas cost us 50 cents per thousand in the holder it is far better to know it and aim for better results, than to deceive ourselves and companies into a belief that it is only one-half that sum. Every item entering in, no matter how trifling, is as essential to an accurate and equitable result as the undisputed items of coal and labor—as in any other line of business—we want an exact balance.

No question arises as to weights and measures, this Association having adopted a standard as follows :

- 2,240 pounds 1 ton.
- 2,150.42 cubic inches . . . 1 bushel of lime.
- 2,747.70 cubic inches . . . 1 bushel of coke, (heaped bushel).
- 231 cubic inches 1 gal. tar, naphtha, oil and ammoniacal liquor.

To arrive at the component parts (aside from chemical details) of a given quantity of gas would be to arrive at its cost in the holder—upon most of these there will be no argument—others will probably invite discussion. In the form we submit for your approval we embrace :

- 1, coal ; 2, oil ; 3, labor ; 4, purification ; 5, fuel ; 6, water ; 7, expense ; 8, maintenance.

And apply the following rules in connection with them. We would say at this point by way of explanation, that the figures we will recommend as fixed charges are in each instance the result of a consensus of opinion derived from sources we considered particularly well qualified to testify from experience and who were equipped with reliable data.

Manufacture.

Coal.—Total cost, initial and ultimate.

This should include every additional expense after its first cost, storage, insurance or any similar charge, and as nearly as possible a just allowance for shrinkage. If coal is sold or in any other way a profit de-

rived the account, should be credited with the amount. In the matter of shrinkage, instead of periodically marking off for discrepancy, between coal weighed in and coal accounted for, there should be a fixed charge sufficient to cover the loss in weight and waste ; your Committee recommends for this a fixed charge of 1 per cent. That is to say, if the coal used in a given month figured as above \$1,000, before dividing to ascertain the cost per thousand 1 per cent. should be added, making the cost of coal \$1,010.

Oil.—Apply the same rules as for coal, except that in the use of naphtha we recommend for evaporation and waste a fixed charge of 5 per cent., and in the use of crude oil, 3 per cent.

Labor.—More difficulty has been experienced in finding a satisfactory solution of this feature than in any other part of the problem, owing particularly to the fact that each size of works develops different assignments of duties of officers, the division being more intricate as the works diminish in size ; in the larger works the lines being more clearly defined this difficulty largely disappears. We therefore present the following : In the distribution of this item to arrive at the proper distribution of official salaries, we must first define the significance of the various titles in use, or define titles that may be used to afford a basis for distributing the amount so as to as nearly as possible assign an equitable division to its proper place. We therefore define the various titles as follows :

General Manager.—One having supervision of and supreme authority over all departments and affairs. Salary—One-fourth, manufacture ; one fourth, distribution, and one-half, management.

General Superintendent.—One having supervision of and authority over manufacture and distribution, but not over office affairs. Salary—two-thirds, manufacture, and one-third, distribution.

Superintendent.—One having supervision of and control over manufacture alone. Salary, manufacture.

Superintendent of Distribution.—One having supervision of and control over distribution. Salary, distribution.

By selecting or combining these a suitable apportionment may be secured in almost any case. In a small works, where one man is the Poohbah of the entire plant, occupying all the offices and practically doing all the work, outside of manual labor, he should for our purpose style himself General Manager and distribute his salary as shown above. This part of the labor will be placed under the heading "Salaries" in each department—manufacture, distribution and management. Labor would thus comprise, salaries, wages of foremen, wages of stokers, wages of coal-handlers, wages not specified above.

Purification.—Cost of labor, cost of lime, cost of oxide.

Regarding the item of labor, where a purifying crew is constantly employed, or in smaller works, where only part of a crew or even part of one man's time is employed, the charge should be made for the actual time.

If oxide is used, we recommend the following : Determine and use a fixed charge per 1,000. For example, if the material costs 48 cents per bushel delivered at the works, and its lifetime is equivalent to purifying 120,000 cubic feet of gas, this would equal a charge of $\frac{4}{10}$ of 1 cent per 1,000 for material ; add to this the cost of labor at, say, $\frac{5}{10}$ of 1 cent per 1,000, and we arrive at a fixed charge of $\frac{9}{10}$ of 1 cent per 1,000 as the cost of purification, where this material is used. Some works will do better than this—others not so well. We consider the above, from our investigation, a fair average charge:

Water.—Where water is purchased, the rate per 1,000 is readily obtained ; if pumped, the cost would appear in the two items, Fuel and Maintenance.

Fuel.—All fuel, other than coke, used for boilers, generating or furnace firing. No coke should be charged, inasmuch as the credit to cost of gas in holder is from coke sold. In the manufacture of water gas it would, of course, be necessary to keep an accurate account of coke used to determine the cost of that gas, as compared with coal gas, but this would not affect the cost of the combined gas, in the holder.

Expense.—This should include the minor items of expense at the works, such as oil, waste and similar supplies.

Maintenance.—This item should embrace all repairs, including renewal of retorts ; we, however, recommend a fixed charge, inasmuch as the variation is not only in months but in years. As near as your committee can ascertain, this amount is variable in different sized and situated works, varying probably from 3 to 7 cents per 1,000, making presumably a fair average charge of 5 cents per 1,000.

Less Residuals Sold.

Coke.—To include all receipts for coke, less expense of delivery, or preparation for market. To include any coke on free list at a fair valuation.

Tar.—Sales, less expense of delivery, cooperage, or preparation for market.

Ammoniacal Liquor.—Sales, less expense.
This would give "Cost of Gas in Holder."

Distribution.

Salaries.—Already explained.

Meters.—Wages of meter takers, wages and expense in meter department, including repairs and renewals; wages of collectors and collection expense.

Mains and Pipes.—Renewals and repairs of mains and service pipes, less income from rental where meter rent is collected. This would give "Cost of Gas Distributed."

Public Lamps.—Expense: Lighting, extinguishing, repairs, renewals and maintenance.

Management.—Salaries, as explained; officers; general, to include salaries not apportioned in former distribution; directors' allowances, office rent and office expense.

Sundries.—Taxes, insurance, inspectors' fees, legal expense, bad debts, sundries—to include items not readily distributed to other accounts.

The form is now complete except for the item of leakage. Usually the custom adopted is to carry the items of cost into columns of Gas Made and Gas Sold. Your Committee believes, however, that a preferable way is to place this item, after the items of cost are summed up, as a calculation based upon that sum, multiplied by the per cent. of leakage, divided by the percentage of sales. For example:

- 10 per cent. of leakage equals $\frac{1}{10}$.
- 12 per cent. of leakage equals $\frac{1}{8\frac{2}{3}}$.
- 14 per cent. of leakage equals $\frac{1}{7\frac{1}{4}}$.

And so on. The rule, then, for figuring this item would be: Multiply the net cost of gas made by the percentage of leakage, and divide the quotient by the percentage of gas sold.

This arrangement does not interfere with the clearness of the detailed statement of cost, saves a considerable amount of unnecessary calculation, and gives the desired result in an accurate and crystallized form. In the present instance we have chosen to adopt as the charge for leakage, 10 per cent. We therefore present the plan suggested, formulated upon the foregoing basis. The figures used are taken at random while seated at the type-writer, and are only accurate as an illustration of the form.

Cost of Gas.

Manufacture—

1. Coal2000
2. Oil0359
3. Labor1542
4. Purification0109
5. Fuel0101
6. Water0505
7. Expense0041
8. Maintenance0500
	— .5157

Residuals Sold—

9. Coke1412
10. Tar0638
11. Ammoniacal liquor0190
	— .2240
12. Cost in holder2917

Distribution—

13. Salaries0713
14. Meters0240
15. Mains and Pipes0701
	— .1654
16. Less income0204
	— .1450
17. Cost distributed4367
18. Public lamps0103

Management—

19. Salaries1010
20. Allowances0100
21. Office expense0520
	— .1630

Sundries—

22. Taxes0100
23. Insurance0040
24. Inspector's fees0010
25. Legal expense0050
26. Bad debts0010
27. Sundries0020
	— .0230

Net cost of gas made..... .6330

Net cost of gas made..... .6330
28. Leakage ($\frac{1}{10}$ of .6330)..... .0703

Net cost of gas sold..... .7033

Respectfully submitted,

J. D. THOMPSON,
GEO. G. RAMSDELL, } Committee.
A. W. LITTLETON,

Discussion.

The President—You have heard the report of the Committee, and we would like to hear what the members have to say as to the suggestions of the Committee. A great amount of labor has been expended in preparing this valuable report, and those members who are seriously interested in the matter are anxious not only to get an expression from the Association of the desirability of adopting such report, but would also like to get an expression from the Association to the effect that the members would agree to take up this matter, or this form of keeping accounts, so as to form a basis of comparison by one company with another. The Committee have labored well, but are not entirely satisfied with the details which they have presented, and would like to have suggestions from members. I hope you will not hesitate to make remarks.

Mr. Ambrose—The Committee have really done their work so thoroughly that they have not left much for us to debate on, except in a general way. It is evident we have a great many accomplished accountants here, and it seems to me that they can agree upon some uniform system in order that abuses may not arise. We know that often one man will report he can put his gas into the holder at 25 cents per thousand; and the public, through the newspapers getting hold of that statement, figure on it without taking into consideration any of the other items of cost—probably he has not figured in one-half the labor that enters into the cost of putting gas into the holder; but the public noting only the bald statement cry out that if gas can be put into the holder for 25 cents per thousand we ought to sell it for 35 or 50 cents. That is really the way that so many abuses of the gas interest have arisen all over the country—from the very fact that these statements have been made without any thorough investigation of the question, and without taking into consideration all the items that enter into the cost of gas making. I heard it stated that the people of St. Louis could put their gas into the holder for nothing, and still make money; that is, that the by-products which they sold amounted in value to more than sufficient to pay all expenses. The public got that from some false data given them, or from conclusions based on statements made by parties who are not disinterested, or from estimates, without considering all the items which should enter into the cost of gas making. I understand it is now proposed to adopt some uniform system by which we can ascertain the cost of gas, and then, when our statements go out to the public, they will be uniform, and each and every one of us who are interested in the gas business can take up the cudgel and help the man out who is the under dog in the fight. Indeed, whenever the generous public, and all the newspapers of the country, jump upon one company, unless other companies come to the rescue they will be considerably "woolled" before they are through. That has been the case in some of our extreme Western towns. It has got so now that in some of the small Western towns (those having a population of only 4,000 or 5,000) the claim is made that the local companies ought to sell gas at 50 cents or 75 cents per thousand, when in fact it costs the company that much or more to put the gas into the holder, owing to the fact that they manufacture such a small quantity, because of the small demand, that they cannot afford to sell it at the price they could if there was a greater demand. We are not exactly like our Jew friend who said he was selling his goods ten per cent. below cost, and was asked how he managed to make a living? Said he, "Because I sell so much of it." That is not exactly the way with us. We want a little larger margin of profit.

Mr. Egner—In buying coal we have to pay for it at the rate of 2,000 pounds per ton, but I understand that it is the established rule of the Association to call 2,240 pounds a ton. I think that ought to be changed. It would be much better for all of us if we could agree upon 2,000 pounds to the ton. We have to buy our coal in that way in all the Western States.

Mr. Shelton—I think we all agree upon the necessity of a uniform system of charging up the cost of gas in the holder. I do not desire to criticise the report of the Committee, but for the sake of provoking discussion there are one or two things about which I should like information. I would like to ask the reasons that guided the Committee in coming to the conclusion about charging up the shrinkage of coal. It is a very hard thing to determine what the whole shrinkage is. It is an extremely difficult thing to go into a coal shed and tell just how much

coal you have on hand. As to the item of oil, the Committee seems to lay down an arbitrary rule of charging off three per cent. for crude oil and five per cent. for naphtha. With the coal we cannot find out very definitely what the exact waste or shrinkage is; but there is no trouble in charging off the oil account. I think also that three per cent. for crude oil or five per cent. for naphtha does not give a sufficiently wide margin. For crude oil the evaporation may not be more than three per cent., but for the naphtha I have frequently found it to exceed five per cent. Another point is as to the cost of maintenance. It is suggested that some companies should charge off three cents, and some seven cents, or that, perhaps, an average, or a fixed charge, for maintenance would be five cents per thousand. I think a company that could figure out an actual cost of three cents per thousand would not be satisfied to charge off five cents per thousand, because some of their neighbors did not do better than that. I think we ought to charge off in each case the actual cost of the labor, and not the average cost to all the companies. I would like to ask the reason for that recommendation.

Mr. Ramsdell—In the matter of the weight of a ton of coal, the point that Mr. Egner suggests occurred to the Committee, in fact they started out on the assumption that 2,000 pounds was the standard for a ton of coal. But in looking that matter up we found that this Association, at its meeting in Cincinnati, several years ago, adopted the standard of 2,240 pounds to the ton. I thought myself that, for this Western Association particularly, it should be 2,000 pounds; for we all buy our coal in that way, and it is much easier to figure. As to the items charged off for shrinkage of coal and in oil, the Committee, of course, had very limited knowledge themselves of these things, but they obtained data from all parts of the country—more particularly from companies which we thought would make statements that could be depended upon—and then made a general average of those amounts. In the matter of oil, I think we could get at it very closely, because we have the actual figures. I think, if I remember rightly, the data represented something like four or five million gallons of oil. So that, having that large amount, and taking the average in that way, your Committee thought they would arrive at very close figures. As far as the repairs are concerned—that was a very difficult question for the Committee to decide upon, owing to the fact that there is so much variation. Every company will at some time pretty nearly remodel its entire works. If that expense were charged in in any one year it would make the cost of gas for that year very high. The Committee endeavored to distribute that in proper proportions. As I say, the returns we received on that subject varied from three to seven cents per thousand, in round figures. We judged from that, considering the sources we had drawn those figures from, that to adopt 5 cents per thousand feet would make a fair charge. Of course, if we all charged 5 cents per thousand for repairs it would make no difference just how much or how little repairs we made, as the cost of our gas would then figure just the same. The items that there can be economy in should be put in here at just what they actually cost. The only reason why we adopted the plan for oxide purification was that your oxide may last for three, four or five years; it does not all give out in one year. If you buy a certain amount of oxide the first year, and then buy more the next year, it would be easy to calculate it in that way; but inasmuch as the cost of the oxide covers more than one year, and it is difficult to equitably apportion the cost between the different years, we adopted this plan.

Mr. Shelton—I do not think the Committee got at a very exact average. The amount spent for labor or repairs speaks for itself; but those other expenses we cannot definitely determine, and it is very hard to make an estimate. Those items which we can determine—which we know exactly how to charge up each year—I think should be stated exactly. I think it would be difficult to explain to our directors, if we were only actually paying two cents per thousand feet for repairs, why we charge up 5 cents per thousand each year. I think they would be apt to want to know why we charged more than two cents.

Mr. Ramsdell—I will say one thing more. Mr. Shelton is in the U. G. I. Co., and that Company's system of keeping accounts is very fine indeed. They are kept in detail, and it would be very easy to keep them year by year if that system was adopted. But that plan involves a large amount of work—more than the Committee felt authorized to recommend for adoption by the Association. We do not expect even that the plan we have suggested will be at once adopted, but that the ultimate form will be like it. Unquestionably there will be changes. We thought it would be better to adopt some simple standard now, and then work into a more perfect system by-and-by.

Mr. Lansden—The object of this Committee, as I understand it, is to induce our members to bring in these accounts in such a way that we can make comparisons among ourselves, so that the Association can un-

derstand exactly what we mean when we say that gas costs so much in the holder, or so much distributed.

Mr. Ramsdell—I was just going to say that of course we can present no report which will bind anybody. As a matter of fact each of us now has some system upon which he is keeping his accounts. The object we had in view was this: We come together as an Association, and here and in our conversations we ask a man how much his gas costs him in the holder; sometimes the figures given are very satisfactory, and sometimes they are somewhat paralyzing. The reason is because they are based upon false data. In other words, one man has figured one way and another in another way. If we could adopt some system by which, when we ask a man what his gas cost him in the holder we knew that in his reply he embodied just what we represented in our own case, then we would know whether we were or were not doing good work. The original idea in this paper was to cover that point. Of course it would be impossible for the members of this Association to go home and change their whole system of bookkeeping to adopt anything like this; but if the Association would adopt this report or any similar form of keeping accounts, we could gradually grow into its general use. If the Association prefers, this report can be referred to another committee to devote more work upon. I will say that in my own case I have adopted this form and am now using it to my satisfaction.

Mr. Starr—Does it not increase your labor very largely?

Mr. Ramsdell—Not at all; on the contrary, lessens it.

Mr. Cowdery—I move the Secretary of the Association have a set of blanks printed, corresponding with these forms proposed by the Committee, and that they be distributed among the members, and that the members carry them home, figure it out on their own account during the coming year, and come prepared at the next meeting to discuss the subject and to say whether their companies are ready to adopt this form, or some one similar to it.

Mr. Murdock—I would like to have that motion amended so as to correspond with Mr. Egner's suggestion that 2,000 pounds be considered a ton of coal.

Mr. Forstall—I think there is an error on the 12th page. It says: "Cost distributed, .4367." I think it should be "Cost of distribution."

Mr. Ramsdell—The cost of distribution would be .1450; the cost of distribution added to the .2917, cost of gas in the holder, gives us the cost distributed as .4367. In other words, that is the cost in the holder and the cost of distributing.

The President—You have heard the motion of Mr. Cowdery—that the Secretary be instructed to prepare forms based upon this report to be submitted to the members of the Association for their consideration during the coming year and discussion at our next annual meeting. Mr. Murdock moves to amend that by fixing the standard of a ton of coal at 2,000 pounds instead of the standard of 2,240 pounds which was adopted by this Association some time ago. The question presented is susceptible of division. I think that to keep the matter clear we had better put the motion of Mr. Cowdery as originally made, and then the matter of fixing the number of pounds to the ton of coal can be taken up as a separate motion.

Mr. Murdock—I will withdraw my amendment.

Mr. Egner—I would like to know what I am voting on. I understand that the Committee report recommends certain forms to be used, and that these figures are simply given the better to explain these forms.

Mr. Ramsdell—They are simply illustrations.

Mr. Egner—I suppose every one understands that, and that we are to figure the coal and all the other items at whatever they actually cost us. I think it would be well not to allow a fixed charge of 1 per cent. I have found it sometimes to exceed that, and sometimes to be nothing at all. I think we should add the waste as we really find it in our several works. As to the oil, I do not lose any oil at all; hence I would not like to add 5 per cent. for leakage to the cost of the oil. I suppose the intention is to take the form proposed and to use the figures as we actually find them.

The President—As I understand the report as read it is necessary that some percentage be adopted. The Committee, as the result of their investigation, found certain percentages which they have recommended. The discrepancies between the actual and the calculated percentages would readily be removed in our inventory. Our inventory would show how far we had erred in them. For the information of the members (myself included) I would like to ask Mr. Shelton, if this 5 per cent. is an error, what percentage he would recommend according to his experience?

Mr. Shelton—I would not recommend any fixed percentage. Sometimes we have no loss at all; then again we have a loss. On the naphtha I have known the loss to run from 5 to 15 per cent. I do not think

we ought to charge off any arbitrary percentage for the evaporation of oil. You can determine the exact amount in each case, and should state it, leaving the arbitrary percentages to those things which cannot be determined.

Mr. Ramsdell—The Committee thought that matter over very seriously. This is not put in without a great deal of thought with regard to that particular point. I presume there are very few men in this room who charge off for any loss in oil or coal. There may be some, but I think I am not overstating it when I say there are few in this room who charge off anything. I mean by that to say that there is nothing charged off regularly. Once in a while, as it happened in my own case at one time, I got my coal house cleaned out—I very seldom get the entire lot of coal taken out—and I was surprised at the discrepancy which I found. It extended over a number of years, and I was surprised at the large shortage that I found in my coal account. It is a very easy thing to keep your books so that your coal account is charged off with the amount of coal used or sold; and that is the way it is almost universally done. As Mr. Falen has suggested, the inventory will take care of that. In my own case I found that over 100 tons of coal had been lost through waste, or in weighing, or in some such way as that. That is an actual loss as far as gas manufacture is concerned, and it should be charged up to the actual expense of the gas made during that time. And in the same way with oil. It is lost either by evaporation or waste, or by measuring. It was to cover that and to get what we thought was a fair charge to be put in regularly that this suggestion was made. If every man here would balance his accounts, as Mr. Egner says that he balances his oil account, every day, or if every man balanced his coal account every day, we could get at the figures accurately, and it would be better for every man to keep his accounts in that accurate way; but the trouble is that it is not done, especially in the smaller works. It was to cover that point and to get a fair charge that the Committee recommended that course.

Mr. Ambrose—If I understood Mr. Cowdery's motion it was that printed forms be furnished by the convention to each of the companies, and that the matter be referred to the Association as a Committee of the Whole to report at the next annual meeting.

The President—That is the idea.

Mr. Egner—I want to say I am heartily in favor of this system, and I know that it has taken a great deal of work to get it up. I believe if we all follow it out it will lead to good results.

Mr. J. B. Howard—I move to amend the Cowdery motion, by suggesting that the reports made by different members during the year be made upon the form taken from the report of the Committee. If they see fit to make any different reports, these can come in also. It would entail too great hardship upon the Committee to get up the exact forms and send them to every member of the Association. It is asking too much of the Committee. I think the report itself is sufficient.

Mr. Starr—I think that that system is asking too much of the companies. You might just as well, in making up your family expenses, have a column for onions, one for meat, and one for flour; why not? The system we pursue is this. We charge up to the gas the cost of everything that we purchase to make gas of. We have an account for construction, and of expenses for repairs. We put in the cost of putting in street mains, if any have been laid. We charge the pipe and labor at cost. Where we put a new pipe in a new place we charge that as construction. We charge what we buy to the expense of the gas. We take an account of it at the end of the year and see how much we have got left. I think this makes it much more simple, and it would suit small works. In large works where you have large accounts, you may take something like the Committee plan. The loss in the coal account is principally due to the moisture in the coal. As to the oil, I do not think we lost a barrel of oil out of a year and a-half supply. I have a tank in which the oil is water sealed, the tank being constructed on lines suggested by Mr. Forstall.

Mr. J. D. Thompson—As I understand the report of the Committee it is not their intention that any company shall charge itself with a loss which does not actually occur. If the experience of the company is that its loss is not one per cent., and know it to be the fact, they will charge off exactly the proper amount. It is no more right to charge off one per cent. for loss of coal when the loss does not exist than to charge \$5 per ton for coal when you do not pay that much for it. Ordinarily the coal is not inventoried except at stated times. We inventory our coal once a year; that is we use up all the old stock of coal, and then we know exactly what loss there is, if any. But during that time, instead of the loss coming all at one time, we each month charge off what we suppose to be the proper amount. In the case of oil, as Mr. Egner says, we balance that every day, and it is done in this way. We have a certain

amount of oil on hand, as indicated by our tank; next morning the amount of oil is taken—the amount then actually on hand—and the difference is the amount used besides whatever may have been put in the tank during that time. So that in all these things, where the Committee recommend certain percentages, they do it simply as a basis to figure on, with a view of letting each company make the actual figures as their experience suggests.

Mr. Jenkins—I want to make a reply to the suggestion made by Mr. Starr. If we were each individually to take a balance sheet every month, and put down what we paid out for onions, and for beefsteak, etc., I believe that after a few months we would find our expenses would be just a little bit less the coming year. If we were to do the same thing in the gas business I think we would be surprised at the results. I am heartily in favor of this plan, and think we should adopt it as soon as possible. I have within the last few months, on several occasions had an opportunity to see the reports made out by our friends of the United Gas Improvement Company, and have been struck with their minuteness of detail in every respect. I know it entails a good deal of trouble to carry out such a plan, but I believe it will be found entirely satisfactory when once put in practice. I have in my mind a friend who says now that he would rather follow out this plan than any other that he has ever tried; for he knows at the end of every week just where he stands. I think we would profit very much by the same experience.

Mr. Cowdery—My only idea in calling upon the Committee to prepare these blanks was to prevent a misunderstanding. If each member should prepare his own blanks from this report there might be a dozen different styles of blanks. If it is thought best to have some amendment to this motion, I will accept it.

Mr. Ramsdell—Before the motion is put I want to say that as I understood it, it referred the matter back to another committee for consideration for another year. This Committee does not want to continue the work. The Committee has perfected all they can do, and desires to be discharged. If there are any blanks to be prepared I understand that the motion instructs the Secretary to prepare them.

The President—The question is on the amendment offered by Mr. Howard, which I will ask him to state again.

Mr. J. B. Howard—My amendment is that a statement be made up on the report of the Committee; that instead of having this Committee, who have devoted so much time in getting up the plan, assigned more work, that each member of the Association prepares blanks in accordance with the suggestion of the report and submit them to the Association.

The President—The original motion, as offered by Mr. Cowdery, was that the Secretary be instructed to prepare blank forms based on the report of this Committee, and that a copy of those blank forms be submitted to each member for his consideration during the year, and that the matter come up for discussion at the next meeting. That original motion was amended by Mr. Howard, who proposes, instead of the Committee doing this work, that each individual prepares a blank form from the report. The question is now on the amendment.

Mr. Harbison—I hope the amendment will not prevail, but that the original motion, that the Secretary prepare uniform blanks, shall prevail, so that every member of the Association may work on the same basis.

The Howard amendment was put and defeated.

The President—The question now is, on the motion of Mr. Cowdery: That the Secretary be instructed to prepare blank forms based on the report submitted by the Committee, and that a copy of those blank forms be submitted to each member during the year for consideration.

Mr. Lansden—I wish to offer an amendment—that each man receiving blanks fill them in according to his experience and return them to the Secretary.

The President—That matter comes up for discussion next year. The amendment is not in order.

Mr. J. B. Howard—I want to place myself right. I did not understand the motion of Mr. Cowdery was that the Secretary furnish those blanks. I presumed the motion directed the Committee to do it, and I did not want to impose any more work on the Committee. (The motion of Mr. Cowdery was agreed to.)

The President—The question now is on the report itself.

Mr. Shelton—I move that the report be accepted, and that the hearty thanks of the Association be given to the Committee for the evidently great amount of work that they have bestowed upon the report. (Agreed to.)

Mr. Murdock—Now I move, before those reports are sent out, that the standard weight of a ton of coal be changed from 2,240 to 2,000 pounds.

The President—I will have to ask for information from the Secretary whether the change can be made in this way by motion.

Mr. Ramsdell—Of course, it would be very easy to change that by motion as has been proposed, but I think we should not act hastily in this matter. When this standard was adopted, Mr. King, who was chairman of the Committee, told me at the time the reasons (they were sufficiently good then to carry the day) why the Committee recommended 2,240 pounds instead of 2,000 pounds. One reason suggested was that it would enable us more readily to compare results with the gas manufacturers in the East and abroad. I would suggest that, instead of adopting a motion at this time changing the standard (there is no trouble about doing it at any time, because it is neither a by law nor part of our Constitution, but simply a part of our routine business), it be referred to a committee to be instructed to report at the next meeting, or at the same time that this other matter comes up.

Mr. Harbison—I trust that this will not be referred to a committee. I think the members of this Association must see that it is not a wise movement. This matter has been very thoroughly discussed in years past by the American Association and New England Association, as well as by this Association, and all three have adopted the standard of 2,240 pounds. The English have also the same standard. Many of the members of this Association are also members of the American Association, and if they are to bring in statistics for comparison to the American Association they will have to do their figuring all over again, if they do it in the first place on the basis of 2,000 pounds. If our reports of results are worth anything to us by way of comparison they must be all on the same basis. There is no use giving our boards of directors reports of what we have done in juxtaposition to the work of other companies, and then to ask them to compare results, if it is necessary for them to go through so much figuring in making the comparisons. I trust this Association will stand by the action already taken after careful consideration. I remember that our late brother, King, gave very earnest attention to this subject. It was earnestly discussed at a meeting of the Association, who unanimously decided to adopt 2,240 pounds as the standard for a ton of coal. I trust the Association will stand by its former action and not make any change now. We thus keep the standard uniform with that of the other associations in this country as well as with our friends across the water.

Mr. Murdock—I believe this is now the largest Association in the country, therefore it is about time we gave them something to follow after. I insist upon my motion.

Mr. Jenkins—I distinctly remember why it was that 2,240 pounds was adopted as the standard a few years ago. The object was, as Mr. Harbison says, in order that our results might be on the same basis. As each of the other Associations has now adopted this same standard, why should we start in and stir them all up again on this question? If we do they will come to us next year with something else. I think we had better let it stand just as it is. (The Murdock motion was lost.)

The Association then took a recess until 2 o'clock P.M.

SECOND DAY—MAY 22—AFTERNOON SESSION.

The Association met at 2 P.M.

The President—We will first take up the paper by Mr. Allen R. Foote, which probably will not provoke much discussion, but which nevertheless is well worthy your attention.

In the absence of Mr. Foote Mr. E. H. Jenkins, of Columbus, Ga., read the Foote paper entitled

BY-PRODUCTS OF EXPERIENCE.

1. Write the history of the utilization of by-products, and you will write the history of cheap gas. Make a record of the by-products of experience, and you will lay a solid foundation for successful management. Intellect makes a mammal a man. Wisdom makes man a god. Judgment is the highest attribute of intellect. Acts of judgment proceed from a knowledge of antecedent conditions and logical reasoning regarding the ultimate effect of things to be done.

2. Every agent of force under your control yields obedience in unvarying accord with the degree of correctness of the judgment with which it is directed. Accuracy of judgment depends upon the reliability and scope of the data, and the power to determine effect by knowing the cause upon which it is founded.

The true value of a correct judgment can not be determined. You may form an approximate estimate of it by taking account of what an unsound judgment has cost you. For you the day of judgment comes ever with the rising sun. You may choose whether you will pay the price of knowledge and enjoy its benefits, or do without and suffer cor-

responding disadvantages. This is the meaning and limit of your liberty—the power to choose. One thing or the other you must do.

3. You keep accounts. Accounts are records of experience. If you could manage your business equally well without them, you would not keep them. They are essential to good business management, therefore you have to keep them. The value of accounts depends upon their accuracy, the details they cover, and the relation they bear to the accounts of all others in the same business. To acquire accurate accounts covering all details of the business being managed, is the best possible discipline, safeguard and guide for its manager. It is the best and most helpful discipline that he can acquire from his employees. Without such discipline, intelligent, economic management is impossible.

4. How many years have you been in business? If for every year you now had an absolutely perfect record showing in aggregate amounts for each year, the exact receipts and expenditures for every detail of your business; another record showing the prices paid and received; another showing quantities consumed with quantities produced; and still another showing all the details of the mechanical construction, by which the processes of consumption, production and distribution were carried on, how much value think you, would such records have as a foundation and guide for the management of this year's business? Ample as such records would be, they would not cover the whole scope of your business experience. They would leave untouched many of the by-products of experience.

5. You are not a perfect man doing business in a community of perfect people. For this reason there have been in the course of years many complaints against the business under your management from without, and it may be, from within. Had you a judicial record of these complaints, showing by whom and how made, by whom and how answered, by whom and how settled, would not such a by-product of experience have a very great value for you now?

It may be that your troubles have not always been settled out of court. If not, then you have had an opportunity to open a record of legal actions, in which to find the names of plaintiffs and defendants, names of attorneys for both sides, complaints and answers, when, where, before what judge tried, together with the names of the jury, and the decision. If an appeal was taken or a new trial granted, a similar record should be kept of each step, tracing the case from start to finish. Again, in your local record should be found copies of all legal papers, so-called. This record would be another by-product of experience of solid value.

In the revolving cycle of years, you must have been called upon to play an engagement with the municipal authorities of your city in the drama of securing a franchise or public lighting contract, a permit to open streets, extend lines, place lamp posts, or to do some other act of public or private enterprise. Like all other dramas, the plot is involved in mystery. Of these negotiations you may say:

"There was the Door to which I found no key;

There was the Veil through which I could not see;

Some little talk awhile of *Me and Thee*

There was—and then no more of *Thee and Me.*"*

A municipal record of such "talks," as well as of the public proceedings, and accounts of all negotiations with municipal authorities, also containing clippings from the press—the uncrowned king in political affairs—would be a by-product of experience that you would treasure with most jealous care.

Your interests are not wholly contained within your city limits. Every bill introduced into the Legislature of your State, pertaining to gas interests, affects you. A legislative record containing in complete detail the history of every such measure, and, if enacted into law, the effect of the law upon the business being done under it, would be a by-product of experience of great value.

So manifold are your interests, and so far reaching are the causes that affect them, even the State is not large enough to place a limit upon the influences and procedures of which you should take account. The laws of one State relating to the interests of gas companies affect the interests of gas companies in other States. For this reason there should be a national record of State legislation, sufficiently complete to, at least, serve the purpose of an index to all laws and decisions of every State affecting in any way the interests of gas companies. Such a record would enable the companies in any one State to quickly bring to their support the legislative experience of the whole number of States regarding any point of issue. The value of this power will not be questioned. This record would be a by-product of experience of far-reaching value.

6. "Man is infinitely related." You are a man. By a decree of nature, for which you are not responsible, you were made related to your kin. By the business in which you are engaged, you have made your

* "Rubaiyat of Omar Kahyyan," p. 41.

self related to your kind. Nature fused into your blood bonds of union with your kin. So surely as you are the creator of your own fortune, will you fuse into your brain bonds of union with your kind. One is not a family. By a decree of political organization all gas men in a State are made kin. They constitute the family of the State. The laws of the State have fused into their organization the bonds of kinship. They are of one blood. "A touch of nature makes all men kin." One family is not a people. Reaching far beyond the limits of kinship, grouping together all families, is the relationship of kind—nationality. In these facts are found the reasons for and foundations of State and national organization.

7. Reliable data covering a broad scope, and the power to determine effect by knowledge of cause, are the sure foundations of an accurate judgment. Such a foundation cannot be laid in isolated or unrelated records.

If you see value for yourself in the records of your own experience, kept as indicated, you must concede that the privilege of comparing your records with others of the same character will be a decided advantage.

"One swallow does not make a spring." One experiment does not establish a rule, nor will the records of one company prove the soundness of a business policy. If you wish to know that you are doing the best that can be done in the management of your business, you must compare all details with as many other companies as possible. The larger the number, the more value will there be in the conclusions. You know the value of your own records. Do not be egotistical. Concede the same value to the records of each company in your State. Form a State Association, to include every member of the family, and make an even exchange of experience with them. What will be the result? Without the loss of any of the value of your records for yourself, you will gain the benefit of the records of every company in your State. It is a peculiarity of the by-products of experience that the more they are used the more value they produce.

8. No man is content to live always within the limit of the sphere of his own family. He has a natural desire to know more than such a narrow world contains. He instinctively reaches beyond his kin and forms associations with his kind. To do this, State associations can be brought into affiliation through a national association. The individual company losing nothing in the value of the by-products of its own experience for its own use, may gain the value of all such products of the companies in the whole country. With experience of a thousand companies at his command, the judgment of any manager will be so confirmed and guided that a cause of mistaken judgment will be all but impossible. In this arrangement you buy the experience of all others in even exchange for your own, without parting with it; you only show it.

9. Your experience kept to yourself is the one talent rolled in a napkin and hidden in the earth. Give it to the companies of your State, and it will produce fifty talents. Give it to the companies of the nation, and it will produce a thousand talents. By co-operation all benefits are multiplied and expenses are divided. For your own experience you pay the whole cost. For the experience of the companies of your State you will pay your pro rata share only—say one-fiftieth of the expense of collecting, tabulating, and publishing. For the experience of the companies of the nation you will pay only one-thousandth of the expense, provided all companies enter into the plan.

10. Something more must be done, however, than the mere submitting of records for inspection. That they may be properly compared and tabulated, an agreement must first be had as to the form in which the records shall be kept. Uniform names for accounts must be adopted, the items must be specified that are to be charged into each account, and a uniform date for closing accounts and reporting must be fixed. In other words, a system must be established, and you must become an integral part of it. I use the word "must" because no other word is suitable. If you would receive the benefits you must comply with the conditions. These conditions are not of my making. They are prescribed by natural law. *If you wish to receive, you must give.*

Without a uniform system of record, all attempts at a comparison of details and results with other companies will be as unsatisfactory as an attempt at railroad travel would be if each company had a track differing from all others in gauge. Without such a system you are like an army in which each regiment has an individual style of uniform, and carries arms differing from all others in caliber. Such regiments are hopelessly incompetent to support each other in any action or extended campaign.

11. This is the proper place for the objector to put in his work. He should talk about "the abridgement of personal liberty;" "the invasion of private affairs;" about being required to "give away" his business.

Were such objections to be heeded, the human race would be turned back into a herd of wild animals. Such ideas are genuine soul shrivellers. There is an ignoble personal liberty, as of the beast, that helps no one and is helped by none. There is a noble personal liberty, as of the volunteer soldier who maintains the touch of the elbow with his comrades, as the army of progress moves forward in the grand march of human destiny.

12. In all that I have said there is nothing that is peculiar to your Association. The principals I have elucidated apply with equal force to every form of business and to every organization.

On the 5th of March, 1889, at the invitation of the Inter-State Commerce Commission, a general conference of railroad commissioners was held, in which nearly every State and territorial railroad commission was represented, as was also the department of internal affairs of Pennsylvania; the American Railway Accounting Officers, by its President and other officials. In an address of welcome, on behalf of the Inter-State Commerce Commission, its Chairman, Thomas M. Cooley, said:

"We are all engaged in kindred work, and not kindred work merely, but in a large degree in the same work. It is of the utmost importance that we should be moving upon the same lines in respect to the railroad statistics of the country; that our respective methods for collecting the statistics should look to like results; that the legislation in respect to them should be as nearly as possible identical, or at least harmonious; and that we should make sure when we use the same terms in gathering statistics that we are using them in the same sense, so that when we gather statistics and place them before the public they should represent actual facts, be reliable, and therefore have value."*

Henry C. Adams, Statistician of the Inter State Commerce Commission, read a paper before the Conference on the subject of "Uniform Railway Statistics." In it he says:

"Uniformity of procedure presents the only feasible plan by which accuracy of conclusions may be insured. Unless statistics are compiled according to uniform rules, it is impossible to use conclusions arising from them for comparative study. Uniformity of method is of such vital importance that this convention ought to be unwilling to separate until some definite plan has been adopted for harmonious and co-operative statistical work."†

After discussion, the following was adopted without dissent:

"Resolved, That it is the sense of this convention that a uniform method of collecting and publishing statistics, both as to time and to matter, should be adopted."‡

Better guides than these do not exist. This convention can do no better than to re-affirm this resolution and then adopt practical measures for carrying it into effect.

13. Co operation is secured by the voluntary exchange of the results of isolated effort for a share in the product of organized action. It does not take from, but adds to the power of the individual. By using the power of co-operative action you can send a message from Maine to California for 1 cent. To get the message there by isolated effort, you must take it yourself and walk all the way. Two courses I set before you: pay your money and use all the resources of civilization that it will place at your command to enable you to keep up with the procession of progress, or, keep your money and hoof it in the rear. You do not want for ability, but for *will*.

"Be but willing, and it shall be done."

Discussion.

The President—If anyone has any questions to ask, although Mr. Foote is not here to speak for himself, I have no doubt that others will answer for him.

Mr. Somerville—It seems to me a pity to pass this over and say nothing about it, because it is really a very important subject. If it is possible to get a uniform system of accounts no one will be more delighted than I, and all of us might say the same thing. Mr. Ramsdell's excellent paper, and the discussion upon it, all tend in the direction of getting a uniform system of accounts. I do not see why it is not possible, although it is not in the near future. In this country many different conditions enter into our plans which make attempts in this direction more difficult than they are in England. And for this reason I think it is almost impossible that you can realize the consummation that Mr. Foote desires in his paper. In England they have a uniform system of accounts by which they can readily compare what they are doing with what others are doing; and no doubt that is a great incentive. When

* Third annual report of the Inter-State Commerce Commission, 1889, pp. 41 and 42.

† Statistics of railways in the United States, for the year ending June 30th, 1888. Inter-State Commerce Commission, p. 344.

‡ Third annual report of the Inter-State Commerce Commission, p. 44.

we see what our neighbors are doing, if they are doing better than we are, we are apt to seek to know the reason why. What Mr. Foote aims at is a very good thing, but there is great difficulty in doing it. I remember one thing that may possibly bring it about. In my address before this Association when serving as President I remember using these words—and I have been struck by them in view of recent events: I said that I could see that the time is coming when the gas industries of this country would be in the hands of one gigantic monopoly. When that time comes I suppose that we shall have a uniform system of accounts. It really looks as if it were coming to that. I think the paper is a most excellent one, and it would be a good thing if we could all strive to this end; but I confess I do not see how it is possible at present.

On motion of Mr. Ramsdell the thanks of the Association were voted to Mr. Foote.

(To be continued.)

Matheson's Patent Lock-Joint Pipe.

The advantages claimed by the American Tube and Iron Company (50 and 52 South Canal street, Chicago) for the Matheson lock-joint pipe are: First, economy as compared with any other joint, the surplus thickness of metal required for a screwed joint being unnecessary; as all other lead or screw and socket joints have a double connection, and as the "Matheson" has but a single one at each joint, a saving of 50 per cent. in this respect is made, and also a corresponding one in maintenance. Second, simplicity in construction, permitting of handling without the aid of skilled labor. Third, a reliable joint, whether used on light or heavyweight tubing. Fourth, a saving in cost of transportation as compared with any other style of wrought or cast iron piping.

The Matheson joint is constructed by enlarging or bellng one end of the tubing, and at the same time forming a lock recess, so that when placed in position the joint is securely locked, and thus prevented from drawing apart through expansion or other causes. On the bell end of the pipe a heavy wrought iron ring is shrunk, giving body and strength at the point of connection for the purpose of calking the lead filling, as shown in the cut. This tubing, when placed in position, is

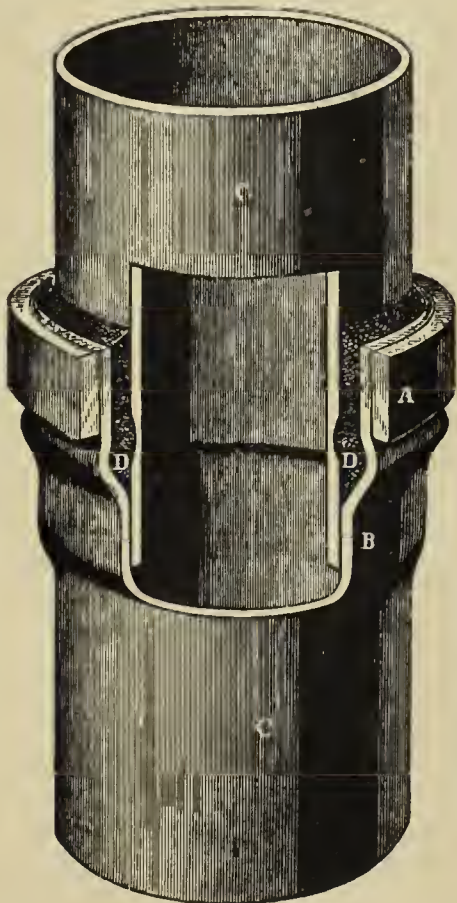

practically flush and smooth on the inside surface, thus offering less resistance to the flow of gas or fluids, and attending loss in delivery through friction, than in the case of other styles and classes of tubing. The Matheson joint is now in use to a great extent by several of the largest natural gas lines in the country, as well as for water and many other purposes. The Company offers no price list on this class of tubing, for the reason that no fixed or arbitrary weights or thicknesses of metal are necessary. External diameters of either standard wrought iron pipe or tubing can be furnished, and of any desired weight or

gauge in connection with the Matheson joint, and in maximum lengths and diameters as follows:

4 to 6 inches diameter,	25 feet long.
8 " 12 " "	28 " "
13 " 18 " "	27 " "

Flames.

Mr. Thos. Fletcher, F. C. S., of Warrington, England, has made another appearance in the field of lectures, this last time before the Corn Exchange, Oxford, where he spoke most entertainingly, before a very select audience, on the subject of "Flames." He commenced by remarking that flames had not received that attention which they deserved, either from a commercial or scientific point of view. Flame, he said, was really nothing but a sign of an incomplete or transition state of chemical combination, and its presence under practical conditions in commercial use always indicated a loss of work. Compared with a boiler whose flues were full of flame, the efficiency of one with hardly any flame was 30 per cent. more. The fact was that the flame was a delusion, hollow and cold inside, and not coming into contact with the boiler at all. A cotton handkerchief saturated with proof spirits of wine would not burn because the flame of the spirits was a comparatively cold and "wet" one, and also hollow—all the space between the handkerchief and the flame was filled with cold vapor; and the amount of heat absorbed in converting the water formed into steam was such that the flame actually became too cold to maintain its existence. The lecturer then proceeded to show, by a number of experiments, how a cold zone exists within a large flame; how the cold zone disappears when the proper portions of gas and air are used; and how flameless combustion takes place when the surrounding solid is at a high temperature. He next showed that a flame does not touch a cold surface, but is separated from it by a cold and flameless zone—a phenomenon which, he thought, had not yet been satisfactorily explained. He believed that it was due to a thin film of air adhering to all substances, but the weak point in this theory was that the zone was also impassable to radiant heat. By another experiment Mr. Fletcher showed that the so-called air gas (air saturated with gasoline) was neither a gas nor perfect mixture, the gasoline being unequally diffused, and, therefore, forming separate and distinct centers of combustion. Continuing, he said it was a very common thing to hear of white flames, but so far as he was aware white flames did not exist. The source of light which was really white was not flame, but some solid intensely heated. He next exhibited the powers of a blow-pipe supplied with gas and pure oxygen, and informed his audience that this destructive apparatus, which can make a slot 3 inches long in a $\frac{3}{4}$ -inch plate of tempered steel in about a minute, can, at some cost, be made to work absolutely silently; and by directing the same blow-pipe upon a block of lime he produced a light strong enough to throw shadows of ordinary gas flames. The fusing of a crucible which would withstand the temperature of fused wrought-iron was another example of the power of this apparatus. Mr. Fletcher next referred to how flame contact can be obtained with water vessels by means of projecting studs, and said that from careful experiment he had come to the conclusion that the effective value of such a surface was about six times as great as that of surfaces with which water is in direct contact—one square foot of surface on a projecting stud is equivalent to six square feet of ordinary boiler or water-tub surface. In conclusion, he referred to the problem of converting a large bulk of heat of low intensity into a small bulk of high intensity, which if solved, would reduce our waste of fuel to zero. This conversion, he said, was possible with all other natural forces, such as light, electricity, etc., and he believed it to be possible with heat also. The only objection, so far as he could see, was that we do not know how to do it at present; but he had no doubt the time will come when the problem will be solved by some one who will be rewarded by fame and fortune.

The Gas Light and Coke Company and Their Men.

We are indebted to Mr. G. Shepard Page, who writes from London, England, under date of May 31, for the following:

The *Press Association* (similar to our *Associated Press*, but perhaps a trifle more trustworthy) claims that through inquiry yesterday (Friday, May 30) it was discovered that the present trouble at the works of the Gas Light and Coke Company has a twofold source. One subject of dispute between the employers and the union is the introduction of labor-saving machinery without the granting of what the men conceive to be a fair compensating wage; and another reason for the present quarrel is the new agreement, proof-sheets of which were sent to the

gas stokers two days ago. The system of inclined retorts reduces manual labor, and in this direction gas engineers are now working. On the introduction of the mechanical appliances into the works at Beckton, the Company offered a wage of 5s. 4d. per day, but their union rule is that no work shall be done on a labor-saving machine for less than 5s. 9d. As this maximum is slightly in advance of the wage of men rated in the first class, the company refused to concede the terms asked, the men on the new machine being given second class rating. The Company maintain that 5s. 9d. a day as a wage would be altogether destructive of any advantage from the use of a labor-saving appliance, and would in fact cost them more than handwork as hitherto used. Seventy-two union men were affected. They withdrew, and non-union men are now inside the works under the protection of a force of 34 policemen. All necessary accommodation has been provided for them within the gates. The inventor himself has been superintending the new hands who are employed on the machine, and is said to be satisfied with the results.

An extension of the new system is anticipated at Beckton, and on the point now in dispute the Company express their determination of not giving way. In respect of the second cause of the quarrel it is clause 2 in the new agreement to which the men object. The first clause establishes the principle of 28 days' notice on either side. The proviso to which the union men refuse assent is in the following words: "If a workman absents himself from work, or leaves without notice to the Company, or shall neglect or fail to perform his work in any capacity in a proper manner by reason of drunkenness or otherwise, or shall refuse or neglect to obey or carry out the directions of any officer of the Company, or be guilty of any insubordination or other misconduct, it shall be lawful for the Company forthwith, and without any notice, to dismiss the workman. In such cases all wages which at the time thereof shall be due, or accruing to the workman, shall be absolutely forfeited to the Company, without prejudice, nevertheless, to any proceedings which the Company may be entitled to take against the workman." The Company have yet obtained no explicit declaration from the men as a body, but a formal reply is expected to be received at the offices on Tuesday, after a meeting of the executive council. The Press Association learns from an authoritative source that such a concession is likely to be made in respect of clause 2 as will meet the men's views, and thus practically secure the withdrawal of terms which the men would regard as constituting a serious grievance if insisted on.

Another Loomis Patent in England.

Mr. B. Loomis, of Hartford, Conn., appears on the register of English patents as the proprietor of No. 9,279. The invention—an improvement on patent No. 15,983 of 1888—relates to the manufacture of illuminating gas by producing a cheap high-grade heating gas, and then carbureting and enriching it with hydrocarbon oil or vapor, and finally combining and fixing the carbureted gas in heated retorts or brickwork flues.

The patentee proposes to make two kinds of heating gas—first, producer gas, resulting from the combustion of coal or other fuel with air, which gas is used for heating the carbureting retorts or brick carbureting chamber, and steam boilers; and, secondly, water gas, resulting from the decomposition of steam in contact with the incandescent fuel, which gas is carbureted with hydrocarbon oil or vapor in manufacturing the illuminating gas. In the operation of heating the fuel to incandescence and making producer gas, the air is drawn into the furnace, and down into the body of fuel, by an exhauster connected with the base of the generator furnace, thus causing a down-draught. By the operation of the exhauster air is drawn into the furnace at top, and down into the ignited fuel; and the resulting gases are drawn off at the bottom of the furnace. In this way a number of advantageous results are claimed to be produced, as follows: First, dust and ashes are blown or drawn into the ashpit, and the formation of clinker almost prevented; second, the oily and tarry vapors distilled from the top layers of freshly charged coal are caused to pass down into the heated coal below, and are thereby converted into fixed carbureted hydrogen gas, instead of passing off at the top and being condensed into tar of little or no value; third, cheap low-grade fuel (such as bituminous coal slack, or mixture of bituminous and anthracite slack or coke dust, etc.) can be advantageously used and more rapidly and uniformly gasified; fourth, the furnace can be much more rapidly charged, and the fresh fuel so placed as to prevent the formation of channels through the bed of fuel, since the attendant can readily work over the top of the furnace and inspect its interior through the fuel opening, by reason of the smoke and gases being drawn away from the top opening and down through the charge by the exhauster.

The highly-heated producer gases are passed from the base of the generating furnace through a tubular or other cooler, and their heat utilized for heating water or air; thus cooling the gases to such a degree that they will not injure the exhauster in passing through it. In this way provision is made for economically manufacturing water gas when using bituminous or soft coal or slack, partly by reason of the down draught used (with the results above mentioned) in heating the coal to incandescence, preparatory to decomposing steam, and partly by reason of passing the hot water gas out of the bed of fuel at a considerable distance below its surface, and then out of the furnace, whereby the injurious melting and caking of the fresh layers of coal at the top are prevented, and the oily and tarry vapors evolved from the fresh coal are caused to pass downward into the hot fuel below, where they are converted into a fixed rich hydrocarbon gas, which mixes with the water gas as it passes into a circular flue and out of the furnace. When the highly-heated water gas is passed up entirely through the bed of soft coal or slack, it produces much trouble by melting the fresh coal and causing it to cake; but by passing the hot gas off below the top of the fuel bed, these difficulties are overcome. The fuel, too, is evenly distributed around the side walls of the furnace, and this prevents the formation of channels and the passage of air, steam, and gases through the channels along the walls. The air and gases are also drawn away from the side walls by constructing a solid hearth or floor next to the walls at the bottom of the fuel chamber, so as to form a contracted grate opening at or about the central portion of the hearth.

It will, of course, be understood that the water gas is generated intermittently; one period being used for heating the fuel by the air draught—during which time a large volume of valuable producer gas is given off—while the next period is used for decomposing steam in contact with the incandescent fuel for the production of water gas composed of hydrogen, carbonic oxide, and carbureted hydrogen. The water gas is thus partly carbureted or enriched with carbureted hydrogen distilled from the coal, and should be a more valuable heating gas than water gas made in the ordinary way. The inventor also provides for thoroughly atomizing the hydrocarbon oil, so as to form a vapor, and intimately mixing such vapor with the hot water gas to be carbureted, by means of a rotary mixing apparatus; and then he converts the hydrocarbon vapor and water gas into a homogeneous fixed gas, by passing them first into retorts or flues at a comparatively low temperature, and thence on through other retorts or flues of an increasing temperature, whereby the oil vapors are gradually expanded and converted into fixed gas and combined with the water gas, without danger of being burned and converted into lampblack.

The generating furnace is built preferably of firebrick covered in the usual way with an outer iron jacket, and provided at the top with a fuel opening closed by a lid. A conical coal distributor, in two parts, is used to direct the coal to the side wall of the furnace, where it is apt to burn away the fastest, so that the fuel will lie at the top in a dish-shaped form. An inclined hearth or floor extends inwards from the walls, and is formed with a central opening into which the grate may be set. The ashpit is of about the same horizontal dimensions as the grate opening; having a brick or tile floor supported on parallel division walls built in the wide outlet flue in the base of the furnace, and forming a superheater. A passageway leads from the ashpit into a flue, and a take-off pipe, having a valve, connects this flue with the base of a retort furnace, from which a pipe leads to a cooler. As an alternative arrangement, the generator may connect directly with the gas cooler.

In the construction of large generating furnaces which are made from 8 to 12 feet in diameter, the patentee preferably forms the ashpit with its outer walls contracted, and of much less diameter than the fuel chamber, so that bars may be readily run up into the fuel through the contracted opening in the circumferential hearth for shaking down the ashes and spent fuel. When the furnace is thus constructed, with a contracted ashpit, the main part of the furnace is partly supported upon pillars. With this construction the bricks or tiles are set in a flue leading to a cooler.

The flue for the producer gas may lead directly from the base of the generator to the base of the retort furnace, where it connects with a combustion chamber. Air, admitted through a passage, flows into the gas through the perforated partition, causing combustion in the chamber; and the flame and products of combustion pass through a perforated partition up into the furnace and around the retorts. Hot producer gas may be passed alone, and without being burned, up around the retorts for heating them, and thence through the cooler to the exhauster, by means of which they are drawn off and forced either through a pipe to a steam boiler, or through a pipe to be mixed with water gas if desired. Or the producer gas may be drawn by the exhauster from the

base of the generator to the base of a brick carbureting chamber, where it is burned by the admission of air supplied through a suitable pipe. Or, again, the producer gas may be passed to the combustion chamber in the retort furnace. Air also flows through the burner to the combustion chamber for burning the gas and heating the retorts.

The retorts are made of iron, and are provided at their rear ends with necks which are set in openings in the rear wall of the furnace. These necks are provided with plugs; while the openings have caps or other stoppers for convenience in setting the retorts in the furnace. The necks are free to slide in the openings so as to permit of expansion and contraction of the retorts. The retorts are provided with horizontal partition plates; and they are connected in vertical series by pipes having openings for inserting a scraper or cleaning bar. Carbureted water gas is admitted from a rotary mixer to the top retort; and the fixed illuminating gas is passed off from the bottom retort.

Instead of the retorts above described, a carbureting chamber may be used provided with brick flues. The walls of the chamber are built of brick, covered with an iron jacket; and it is provided with a central brick partition wall, which extends only through part of the diameter of the chamber, and serves to strengthen the chamber and support the partition plates. A transverse bridge-wall is formed in the combustion chamber at the base of the carbureting chamber; and at the front side of the combustion chamber two bridges are formed, and provided respectively with ports. An air pipe opens into one set of ports, and the gas supply pipe into the other set; and the air and gas are supplied to the combustion chamber through these adjacent rows of ports. The horizontal partition plates extend alternately from opposite sides of the carbureting chamber nearly across it, so as to leave passageways between their free ends and the wall of the chamber. The partition plates form flues between them; and the flues connect with each other alternately on opposite sides by passages. The brick flues, of course, take the place of the carbureting retorts described above.

The rotary mixer used is provided internally with numerous blades connected with the central shaft like a fan blower; and it is connected with a small motor. The hot water gas and a small stream of oil flow together into the mixer, and, by means of the revolving blades, the oil is thrown into fine spray or vapor, and thoroughly mixed with the water gas. The carbureted water gas then flows into the retorts or brick flues, to be therein combined and fixed.

In order to make illuminating gas, the producer gas which is drawn from the base of the generator is conducted to the base of the retort furnace, and there burned by the admission of air for heating the retorts. The lower retorts will be most highly heated; and those above will be heated to a gradually decreasing temperature to the top of the furnace. The water gas is passed from the generator or holder into the rotary mixer, into which the hydrocarbon oil is at the same time admitted from a tank. The mixer is made to rotate, and it beats the oil into fine spray or vapor, and thoroughly mixes it with the water gas; and when the water gas flows hot from the generator, it aids in vaporizing the oil. The mixed water gas and oil vapor pass from the mixer into the upper retort, where the heat is lowest; and then successively pass through the retorts below, in which they are subjected to an increasing temperature, till they are combined and converted into fixed illuminating gas, which flows successively through a scrubber and purifying boxes to the holder.

ITEMS OF INTEREST FROM VARIOUS LOCALITIES.

IN our report of the *In Memoriam* proceedings at the last convention of the Western Association will be found the tribute paid by Mr. Somerville, of Indianapolis, to the memory of Ex-President King—see JOURNAL, June 9, p. 808. We regret to have to say that an error occurs in the report, and we herewith take opportunity to say that in the following sentence Mr. Somerville used the words "the mountains," instead of the word "London." The corrected sentence is: "He laid aside for the time the scientific subjects in which he was so much interested, and the wonders of electricity that he knew so much about, and, joining in the prattle of the children, told them about his journey to the mountains," etc.

THE charter for a gas works at Florence, Ala., granted by the authorities to Mr. C. W. Butterworth and associates, provides for a Company capitalized in \$50,000. The plant is to be of the 8-inch standard, and coal gas will be manufactured. The price of gas (maximum) to ordinary consumers is fixed at \$2.50 per 1,000 cubic feet, and public street lights are to be supplied at the rate of \$33 per post per annum, on an all night and every night table. The officers of the Company are: Presi-

dent and General Manager, C. W. Butterworth; Secretary and Treasurer, C. H. Tatum. Four miles of mains will be put down the first year.

SECRETARY BOGART'S cleverly arranged circular respecting the annual convention of the American Society of Civil Engineers is before us; and from it we learn that the sessions will be held at Cresson, Pa., commencing on the morning of next Thursday. This situation is at once central and charming, and the wonderful recuperative power of the district is shown in the rapidity with which the traces of the terrible disaster of a year ago are being blotted out. A hotel-rate—the house is commodious and well managed—of \$3 per day has been secured. The Trunk Line Association, the Southern Passenger Association and the Central Traffic Association (except in Michigan) have assented to a decreased rate of fare—full fare to Cresson, and one-third full fare on the return. The New York delegation will leave by special train from foot of Cortlandt street, on Wednesday morning, the special to run to Cresson as a second section of the Pennsylvania Company's famous "Chicago Limited," and to leave on her schedule time of 10 A.M. There can be no doubt that the convention will be a grand success from any and all standpoints.

AT the annual meeting of the Willimantic (Conn.) Gas Company, which was held in Newport, R. I., about a fortnight ago, Mr. Howard Manchester, of Bristol, was elected Superintendent and Treasurer, and Mr. Chas. H. Manchester was appointed Secretary. The Directors are: A. P. Sherman, John Hunter, J. C. Swan, J. H. Tilley and Robt. S. Franklin.

SOME time ago we reported the purchase of the Moberly (Mo.) works by Messrs. Hammett & Davis. The latter in reality acquired the property for Mr. James Green, of St. Louis, Mo.

THE Mount Joy (Pa.) Gas Company has changed hands, and important improvements are contemplated.

A CORRESPONDENT, who is well posted in regard to the fuel gas process now in *partial* use at Terre Haute, Ind., sends us the following, which explains itself in the easiest style imaginable:

"ROSE POLYTECHNIC INSTITUTE, CHEMICAL LABORATORY, }
TERRE HAUTE, IND., April 21, 1890. }

"Mr. * * *: Dear Sir—I have completed the analysis of the fuel gas now in use in the city, with the following results:

Carbon dioxide.....	4.6 per cent.
Illuminants.....	13.8 "
Oxygen.....	0.7 "
Carbon monoxide....	8.6 "
Methane.....	6.5 "
Hydrogen.....	6.4 "
Nitrogen.....	59.4 "

Total.....100.00 per cent.

"The small per cent. of oxygen shows that the nitrogen is introduced in the process of manufacture, and does not come from air in the pipes. The illuminants have the average composition of propylene, and the calculated heating power of the gas is about 116,000 calories for 1,000 feet. This is a little less than one-half the heating power of natural gas. From 50,000 to 60,000 feet of the gas would be required to give the same theoretical heating power as 1 ton of good coal. At 30 cents per 1,000 the gas is the equivalent of coal at \$15 to \$17. Since the best of gas could be more completely utilized, however, the real value of the gas is somewhat greater than this would indicate. The gas contains 35 grains of sulphur in 100 cubic feet. The English law requires that gas shall not contain more than 20 grains in 100 feet. The gas in its present state is, therefore, not suited for use for illuminating purposes, or for use in gas stoves where the products of combustion escape into the air of living-rooms. Yours very respectfully, W. A. NOYES."

IN supplementing Prof. Noyes' rather cold figures, we have to remark that the Fuel Gas Company—save the mark, a fuel gas containing 59.4 per cent. of nitrogen—has been distributing its product in Terre Haute for something like 3 months, and now has 22 consumers, 8 of whom are stockholders. We imagine it would be fair to assume that the "faithful 8" are trying to help the scheme along. The Company charges 35 cents per 1,000 cubic feet.

WE understand that though the wires for the electric lighting of the government buildings in Albany have been strung for several weeks, gas is still the illuminating agent employed. The reason for the delay in making the change is a rather odd one, in that there is a clash over the construction of the contract between the United States authorities

and the electric lighting company. The latter insists that the government was to furnish the fixtures, but the former assert the contrary. In the meantime the authorities announce their intention of holding the electricians responsible for the value of the gas consumed.

MR. H. D. FITCH, of Louisville, Ky., who is connected with the ownership of several gas plants in the South, writing under date of the 12th inst., says:

"To the Editor AMERICAN GAS LIGHT JOURNAL: Can you not direct some of your inventive readers to the necessity existing for a combined gas cooking and coke heating stove which will keep gas cookers in use all the year? In my effort to compete with electricity at several points where I control gas properties I recognized the importance of such a cooker. It means an advance of 100 per cent. in the price of coke and doubling the present sales of gas for cooking purposes. Some one who can invent a cooker, combined with a *crushed coke* apartment, which can be used at pleasure to heat the kitchen, and probably do some of the cooking, will make his fortune and do gas companies a great service. I suggest a *crushed coke* apartment, with a gas burner to start the coke fire, with some kind of construction which will utilize the coke fire to heat the oven and yet not prevent the use of the gas apartment when the coke fire is not needed. I suggested this to one or two stove makers, but as yet no good results have been reached."

MR. JOHN K. DAVIS, Superintendent of the Sherman (Texas) Gas Light Company, in his practice of introducing gas cookers follows this course. He recommends the following numbers and table of cost, with terms of purchase:

	List Price.	Gas Co's. Price for Cash.	Co's. Price for Time.
No. 513.....	\$23.00	\$16.00	\$18.00
No. 53.....	20.00	15.00	17.00
No. 33.....	19.00	14.00	16.00

In addition to these prices must be charged the cost of placing the stove, with the necessary connections. The purchaser must pay the first cost of placing the stove and \$5 in cash, and the balance at the rate of \$1 per month until paid for, they to have the privilege, however, of paying up at any time the deferred amounts, deducting therefrom 10 per cent.

THE following from a valued correspondent in Louisville, Ky., who is pretty close to the powers-that-are in the well-managed local Gas Company, is under date of June 11: "Yesterday there was a meeting of electric light and Gas Company officials in the office of the Louisville Electric Light Company, and in a short time it was whispered abroad that the Louisville Gas Company had gathered in the Louisville Electric Light Company. For some time the gas men had been buying up electric light stock, and they bought it not in vain. At the meeting spoken of the following gentlemen were elected to the Directorate of the Electric Light Company—and they are also all in the Directorate of the Gas Company: George W. Morris, astute even if lean, J. M. Atherton, the genial and gentlemanly Harry Bishop, Jas. A. Leech and Brer. A. H. Barret. Messrs. Chas. D. Pearce and T. G. Gaylord, of the electricians, still remain in the Board. All the stockholders who have not parted with their shares can dispose of the same to the parties now in control, at a price that I am not permitted to name. The Gas Company will guarantee the bonds of the Electric Light Company, which will make them worth something more than their former owners ever could rate them at. The Brush Electric Light Company has not sold out, but it is thought to be only a matter of time before the Gas Company will have it also. President Muldoon, of the Brush, said yesterday that the Gas Company had not made them an offer, but that \$65,000 would purchase the entire outfit. And I have no doubt it would, only that the gas men will never give that sum for it."

WE regret to chronicle the death, on June 9th, at his home in Springfield, Ohio, of Mr. Nathaniel Kinsman, who for 33 years has been permanently identified with Springfield's growth. His death resulted from a complication of diseases, and his illness covered a period of several months. Mr. Kinsman's long service with the Springfield Gas Company is a matter of record with the Western fraternity, and a faithful servitor of its best interests he surely was. He was born on June 6th, 1818, at Ipswich, Mass., where he was in due time apprenticed to a joiner, and later removed to Salem, where he drifted for a time into railroading. Emigrating, in 1855, to Ohio, he acted in various capacities on several of the railroads in that State, but finally joined his brother at Springfield in the management of the gas works, remaining in that service when the plant was sold to the corporation known as the Springfield Gas Light and Coke Company. A faithful and conscientious

worker, he refused to relinquish his life's work till failing health compelled him to retire. Energetic and painstaking, he caused the plant under his charge to keep pace with the times. Personally, "Uncle Nat," as he was familiarly known, endeared himself to a wide circle of friends. His brusque manner never veiled his warm, great-hearted kindness, nor ever dimmed the merry twinkle of his eyes. Quick to help where help was needed and deserved, many a youngster owed to Uncle Nat. a debt of gratitude for a timely word of encouragement or more substantial aid. In his business transactions he was scrupulously honest and unusually sagacious and far-sighted. He always believed in the future of Springfield, and was enthusiastic in aiding every project and movement for its best growth. A type of the men who evolved an Ohio from out of Nature's wilderness and into her present prosperity, the death of Mr. Kinsman cannot fail to cause the busiest of Springfield's denizens to reflect, for a brief spell at least, on the caliber of the men who paved the way to their present ease or opportunity. The funeral services were celebrated in Springfield on the 10th inst., after which the remains were sent to Salem, Mass., for interment in the family plot in Harmony Grove cemetery.

MR. M. N. DIALL'S Company (Terre Haute, Ind.) will place at least 125 gas cookers this month. But, then, Diall only charges \$1 a thousand for a fuel gas that does not contain any nitrogen.

THE Paterson (N. J.) authorities will not re-advertise for bids for public lighting, the Committee on Wells, Pumps and Lamps having recommended that the following contracts be awarded: To the United Gas Improvement Company, gas lamps at the rate of \$20 per post per annum, on the basis of a 3-year agreement; to the Edison Electric Light Company, for arcs, first year, \$110 per lamp; second year \$120; third year, \$125; fourth and fifth years, \$135, or an average of \$125 per lamp, on the basis of a 5-year contract.

THE authorities of the adjoining town of Oxford (Ala.) have contracted for a public lighting (arc) supply with the Anniston Gas and Light Company.

CHARLES FRAZIER, colored, was recently killed by an electric light current in the cellar of Chas. Kern's saloon, No. 523 South Fremont street, Baltimore, Md. The following account of the accident is taken from the *Baltimore Sun*. Our authority says: "Frazier went into the cellar to get a keg of beer, and as he did not return promptly, William Lindenmeyer, a youth who attends to the bar, started down to hurry him. As he was descending he smelled a disagreeable odor as of something burning. The first thing that met his eyes was the colored man standing with bent knees, his face turned upward and his hand on the glass globe that was suspended from the ceiling. Lindenmeyer shouted to Frazier that he was in danger, but he did not answer. The barkeeper then ran upstairs and told Mr. Kern what he had seen. The proprietor went to the assistance of his colored man and tried, it is thought, to shove him away from the light, but in an instant Kern was lying unconscious on the ground. Lindenmeyer shut off the current and several men went down the cellar and found both men lying side by side in the darkness. They were carried into the yard and a physician pronounced Frazier dead. The electric lamp was swung in front of a refrigerator, so as to light its interior. It is thought that Frazier, in moving the light to see his way, had caught hold of the metallic socket of the globe, as it is blackened with burned flesh. The glass is also marked. One of Frazier's arms was burnt and cut, and the hand that held the light looks as if it had held a red-hot coal. Mr. Kern regained consciousness shortly after the accident, but said he could only remember seeing a blue light. He does not know whether he touched Frazier or even saw him. He fell or was thrown against a pipe and cut his forehead, marking the iron with blood and hair. Frazier was taken to his home, No. 131 West York street. An electrician states that the wire was charged with 2,000 volts, which is considerably more than enough to kill. The light was one of a circuit belonging to the International Telegraph District and Construction Company, whose motor house is on West Pratt street, near Fremont. Coroner Benson made an investigation, and decided that the death was accidental. Six months ago Mr. Kern's son William climbed in the second story window frame to examine the wires strung near it. He placed his hands on one, and in an instant he was thrown to the pavement and broke one of his arms. Mrs. Kern says that the light will have to be removed."

ACCORDING to *Associated Press* dispatches, dated the 16th inst., Judge McConnell (Chicago) spent the forenoon of that day in listening to the arguments in the People's demurrer to the pleas of the Chicago Gas Trust in the *quo warranto* proceedings brought on relation of Fran-

cis C. Peabody. The main point in the *quo warranto* is the allegation that the Trust, by buying up the stock of other Companies, defeated competition and created monopoly to control the production and sale of all gas manufactured in Chicago. The contention of the Trust, as made by its attorney, was that proceedings by *quo warranto* were not properly brought under this plea; that the remedy of the people must be brought in another way. Finally an order was granted authorizing the Attorney-General to file an additional count denying the right of the Trust to hold any stock at all in other Companies.

MR. AMOS W. R. HENNING, who for the past two years has acted as Secretary and Treasurer of the Niagara Falls (N. Y.) Gas Company, died suddenly, at Suspension Bridge, on the afternoon of June 10th. He was born at Annetta, Pa., on May 5th, 1842, and graduated from Eastman's Commercial College (Poughkeepsie, N. Y.) with the class of 1859. He was a prominent Democratic politician, and served for some time on the Democratic State Committee. He was very much respected by his fellow-townsmen.

THE proprietors of the Randolph (Mo.) Coal and Gas Company have filed a statement of increase of capital stock from \$75,000 to \$200,000.

MR. ALLEN R. FOOTE, of this city, notifies us that the twelfth convention of the National Electric Light Association will be convened at Cape May, N. J., on Tuesday, August 19th. Full details of the arrangements made for the convention will be published later on. Mr. Foote entered upon the duties of Secretary and Treasurer of the Association on Tuesday, the 17th inst.

THE Macon (Ga.) Gas and Water Company has decided to return to the former rates of \$1.25 and \$1 per month for incandescent lamps, in cases where customers agree to shut off their lights on closing their places of business. Those who continue to burn their lights all night must pay the full rates.

A CORRESPONDENT writes that the Gardner (Mass.) Gas Light Company has offered a reward of \$50 for the detection of the miscreant who maliciously opened one of the street valves, thus permitting the escape of a large quantity of gas.

THE proprietors of the New Britain (Conn.) Gas Company will in all probability authorize the addition of a gasholder to the present plant. It is badly needed. [The holder has been ordered.]

SECRETARY CALDWELL, of the Youngstown (Ohio) Gas Company, says that the Company will install an auxiliary water gas plant, work on which will be commenced at once.

THE Louisville (Ky.) Gas Company has notified the citizens that the manufacture and distribution of an exclusively fuel gas has been discontinued. Hereafter consumers can obtain a fuel illuminating gas at the rate of 75 cents per 1,000 cubic feet.

AT the annual meeting of the Exeter (N. H.) Gas Light Company the following officers were elected: President, F. H. Odiorne; Treasurer and Agent, A. M. Copp; Clerk, A. F. Cooper; Directors, F. H. Odiorne, A. M. Copp, W. Burlingame, A. Parker Brown and Samuel Hatch.

PATRICK FLOYD, through his attorney, A. R. Taylor, has instituted a suit for \$10,000 in the St. Louis Circuit Court, against the St. Louis Gas Light Company. Floyd alleges that on April 15, 1889, while engaged in hoisting material for the Company, a defective chain and block caused injuries to his person of a nature sufficient to incapacitate him for work for a long period. The Company's defense is contributory negligence.

THE annual meeting of the Moncton (N. B.) Gas Light Company was slimly attended. The existing Board of Directors was re-elected, the members thereof being the Hon. A. E. Botsford, and Messrs. Josiah Wood, J. L. Harris, C. P. Harris, John A. Humphrey, and Dr. C. W. Weldon. The Directors reported a satisfactory year's business, and a dividend of 4 per cent. for the half year ending May 31, payable July 12, next, was declared. The Directors selected the following executive management: President, John L. Harris; Secretary, R. A. Borden; Treasurer, C. P. Harris.

MANAGER CATHELLS, of the Fredericton (N. B.) Gas Light Company, has been instructed by the management to investigate and report upon

the various systems of incandescent electric lighting, with a view to engaging the Company in the supply of such lighting service.

THE Omaha (Neb.) Gas and Manufacturing Company offered to furnish gas to the local public buildings at the rate of \$1.50 per 1,000. The Thomson-Houston Company offered to wire the buildings and to furnish all lamps, switches, etc., in consideration of the receipt of 1 cent per hour for each 16 candle power incandescent electric lamp in service.

THE bill to give a franchise to the People's Gas and Electric Light and Power Company, of St. Louis, Mo., has been referred by the City Council to the Committee on Local Improvements.

MR. STANLEY and his principal lieutenants in the recent "Emin Bey Relief Expedition" were entertained to a banquet, at the Portman Rooms, Baker street, London, England, on the evening of May 30. A distinguished group of diners faced the board, and the Vice-Chairman of the evening was G. Shepard Page.

THE Long Island City (N. Y.) Board of Aldermen were, on the 16th inst., served with a writ of mandamus to show cause why they failed to audit the bills of the East River Gas Light Company, of Long Island City. The Board have paid no attention to the Company's bills rendered during the first half of the year, and there is no averment that the Company is not fairly entitled, because of services rendered, to full payment. The sum involved is \$14,191.61. The order is returnable before Judge Bartlett.

THE Olympia (Wash.) Gas and Electric Light Company has filed an injunction against the Olympia Light and Power Company, restraining the latter from placing poles so as to interfere with the wires of complainant.

THE proprietors of the Troy (N. Y.) Gas Company are satisfied that the Smith avenue site is ample for their needs.

SUPT. BYRNE, of the Citizens (Brooklyn) Gas Company, is enthusiastic over the development and increase of the business of that corporation.

HERR F. MUCK, in a German contemporary, prints some remarks on the valuation of coal tar pitch. The author considers the test of placing a sample between the teeth a good one for testing consistency. To test the softening point a cylindrical piece of the pitch of 4 mm. diameter and 100 mm. long is bent round the bulb of a thermometer, so that there is a length of 20 mm. on the one side of the bulb and of 80 mm. on the other. The longer limb is fixed parallel with the stem of the thermometer, and the whole placed in a beaker filled with water, and provided with an agitator. The water is then gently heated till the longer limb of the little rod of pitch bends round; this is taken as the "softening temperature" of the sample. As a rule, the softening temperature and the consistency test agree with one another. In the manufacture of briquettes it is important to know whether the pitch used will yield a firm briquette—i.e., one that does not fall to pieces in the fire. Pitch yielding a vesicular coke does not form firm briquettes, whereas that yielding a disintegrated coke does do so.

AT an election for Directors in the Paterson (N. J.) Gas Light Company, the following gentlemen were chosen: John Reynolds, E. B. King, Jas. Dunn, W. L. Williams, John S. Cooke, John H. Reynolds and Wm. H. Williams. The Directors named the following officers: President, John Reynolds; Vice-President, Wm. L. Williams; Secretary, Robt. Schoonmaker.

THE BOILING OF WATER IS NOT A GUARANTEE OF PURITY.—We are accustomed to be told that the most impure water will be rendered pure by boiling, and that in this we have an absolute safeguard against the danger of water containing disease germs. Now, while it is true that boiling will kill the germs of disease, yet the fact has been brought to our notice, says *Annals of Hygiene*, by so high an authority as Dr. Chas. M. Cresson, that while boiling kills the germs of a particular disease, it yet, in reality, renders the water more impure than it was before, because by the very death of these germs, dead organic matter is allowed to remain in the water, which is polluted by putrefaction. Hence, while boiling is a most excellent precaution against the occurrence of typhoid fever or similar diseases, when we have occasion to think that the germs of these diseases exist in the water that we drink, yet we must remember that this boiling does not purify the water; it simply removes from it the specific power to produce a specific disease,



A. M. CALLENDER & CO.,
PROPRIETORS.

EDITOR—**Jos. R. Thomas, C.E.**
ASST. EDITOR—**T. J. Cunningham.**
MANAGER—**C. E. Sanderson.**

PUBLISHED ON EACH MONDAY OF THE YEAR AT
No. 42 Pine Street, New York.

This is a recognized official organ of
LIGHT, HEAT, STEAM, WATER SUPPLY,
VENTILATION, SANITARY IMPROVEMENT,
AND GENERAL SCIENCE

TERMS:

SUBSCRIPTION—Three Dollars per annum, in advance. Single copies, 10 cents.

AGENTS.

NEW YORK.—AMERICAN NEWS CO., 39 and 41 Chambers Street.
Germany.—B. WESTERMANN & CO., of New York.

MONDAY, JUNE 23, 1890.

Gas Stocks.

Quotations by **Geo. W. Close, Broker and Dealer in Gas Stocks,**
16 WALL ST., NEW YORK CITY.
JUNE 23.

All communications will receive particular attention.
The following quotations are based on the par value of \$100 per share.

	Capital.	Par.	Bid	Asked
Consolidated.....	\$35,430,000	100	100½	—
Central.....	500,000	50	85	95
“ Scrip.....	220,000	—	95	100
Equitable.....	4,000,000	100	127	130
“ Bonds.....	1,000,000	—	113	115
Harlem, Bonds.....	170,000	—	—	—
Metropolitan, Bonds....	658,000	—	115	—
Mutual.....	3,500,000	100	123	125
“ Bonds.....	1,500,000	—	100	102
Municipal, Bonds.....	750,000	—	—	—
Northern.....	—	50	—	—
“ Bonds.....	150,000	—	—	100
Standard Gas Co.—				
Common Stock.....	5,000,000	100	—	45
Preferred.....	5,000,000	100	84	87
Yonkers.....	—	50	112	—
Richmond Co., S. I.....	346,000	50	—	—
“ Bonds.....	20,000	—	—	—
Gas Co's of Brooklyn.				
Brooklyn.....	2,000,000	25	118	122
Citizens.....	1,200,000	20	83	84
“ S. F. Bonds... ..	320,000	1000	100	103
Fulton Municipal.....	3,000,000	100	142	145
“ Bonds....	300,000	—	107	105
Peoples.....	1,000,000	10	92	—
“ Bonds (7's).....	368,000	—	100	—
“ “ (6's).....	94,000	—	100	—
Metropolitan.....	1,000,000	100	110	112
Nassau.....	1,000,000	25	130	—
“ Cts.....	700,000	1000	100	102
Williamsburgh.....	1,000,000	50	131	—
“ Bonds... ..	1,000,000	—	108	112

Out of Town Gas Companies.

Boston United Gas Co.—				
1st Series S.F. Trust	7,000,000	1000	93	93½
2d “ “ “	3,000,000	1000	71	72
Bay State Gas Co.—				
Stock.....	5,000,000	50	—	87¾
Income Bonds.....	2,000,000	1000	95½	—
Buffalo Mutual, N. Y....	750,000	100	90	95
“ Bonds...	200,000	1000	95	100
Citizens, Newark.....	1,000,000	50	155	160
“ “ Bonds.	45,000	—	—	—
Chicago Gas Company.	25,000,000	100	54¼	54¾
Chicago Gas Light & Coke Co.—				
G't'd Gold Bonds	7,650,000	1000	97½	98¼
Equitable Gas & Fuel Co., Chicago, Bonds	2,000,000	1000	94½	95½
People's Gas and Coke Co., Chicago—				
1st Mortgage.....	2,100,000	1000	—	100
2d “	2,500,000	1000	96	100
Consumers Gas Light Co., Jersey City.....				
Stock.....	2,000,000	100	20	—
Bonds.....	600,000	1000	80	—
Cincinnati G. & C. Co..	6,000,000	100	201	203
Consumers Toronto....	1,000,000	50	190	200
Central, S. F., Cal.....	—	—	80	90
Capital, Sacramento, Cal	—	—	58	—
Consolidated, Balt.....	11,000,000	100	51¾	52
“ Bonds.....	6,400,000	—	107	107½
Citizens Gas Lt. Co., Rochester, N. Y.....				
Stock.....	500,000	—	75	90
Bonds.....	250,000	—	—	—
Hartford, Conn.....	750,000	25	102	108
Jersey City.....	750,000	20	170	175
Laclede Gas Light Co., St. Louis, Mo.—				
Common Stock....	7,500,000	100	21½	21¾
Preferred “	2,500,000	100	—	69
Bonds.....	9,034,400	1000	83	84
Louisville, Ky.....	2,570,000	50	125	130
Little Falls, N. Y.....	50,000	100	—	100
“ Bonds	25,000	—	100	103
Montreal, Canada.....	2,000,000	100	200	208
Memphis (Tenn.) Gas... ..	750,000	100	40	—
“ Bonds.	240,000	100	103	—
New Haven, Conn.....	—	25	200	—
Oakland, Cal.....	—	—	35	35½
Peoples, Jersey City... ..				
“ “ Bonds..	—	—	60	61
Paterson, N. J.....	—	25	99	102
Rochester, N. Y.....	—	50	99	100
Syracuse, N. Y.....	500,000	25	—	—
San Francisco Gas Co.				
San Francisco, Cal....	10,000,000	100	55½	55¾
Washington, D. C.....	2,000,000	20	200	208
Wilmington, Del.	—	50	88	90

SUPERINTENDENT WANTED

For a small but nearly new and fairly well built and arranged Gas Works. Qualities required are, first, that the interests of the owners and superintendent shall be identical; second, ability and willingness to work; third, tact to deal with consumers in such a way as to hold trade in spite of opposition. Temperance a pre-requisite. Supt. engaged will have entire charge of plant, including books, with no interference except an occasional consultation with the undersigned. Salary, \$1,200. Address 785-2 C. E. BURROWS, Walla Walla, Washington.

Position Wanted

As Superintendent or Assistant in a Gas Works,
By a man who can give the best of references. Thoroughly understands the manufacture and distribution of gas and the construction of works.
785-2 Address “D. D.,” care this Journal.

SITUATION WANTED

As Superintendent of a Gas Works,
By a man of 20 years' experience. Best of references. Address JOHN COLLINS, 324 Clinton Street, Schenectady, N. Y. 785-tf

POSITION WANTED

As Superintendent of Gas Works.

Eleven years' experience in the manufacture of coal gas. Best of references given.

778-8 W. L. CARVER, Supt., Carthage, Mo.

WANTED, A Six-Inch Exhauster.

SECOND-HAND.

Must be in good condition. Roots' make preferred. Address POUGHKEEPSIE GAS CO., Poughkeepsie, N. Y. 783-

WANTED TO LEASE, A Small Gas Works,

By a practical gas man. Address 784-8 “W. E. F.” care this Journal.

FOR SALE.

GAS LIGHT PLANT,

In a growing town of 5,000 inhabitants. Oil Gas Process. For particulars address LATROBE GAS COMPANY, 784-6 Latrobe, Pa.

FOR SALE.

One 5-ft. Station Meter,

8-inch Connections.

In good order. Price, \$300, f.o.b. at Poughkeepsie, N. Y. POUGHKEEPSIE GAS CO., Poughkeepsie, N. Y. 783-tf

Engines and Boilers For Sale

- Five 80-H.P. Ft. W. Bass Automatic Cut-Off Engines,** 12 by 16 in.
- Three 40-H.P. Armington & Sims Automatic Cut-Off Engines,** 9 by 12 in.
- One 50-H.P. New York Safety Automatic Cut-Off Engine,** 10 by 12 in.
- Four Tubular Boilers,** Steel, 16 ft. by 60 in., forty-four 4 in. flues. Full front.
- Two Tubular Boilers,** Steel, 16 ft. by 60 in., eighty 3-in. flues. Full front.
- One No. 5 Dean Pump.**
- Three Sets J. H. Turner Patent Heaters.**

The above are in good condition and in operation. Write for particulars. JENNEY ELECTRIC LIGHT AND POWER CO., Peoria, Ills. 783-tf

FOR SALE,

The Ironwork for Ten Benches of Fives (5's).

Cast iron Hydraulic Main, 16 by 18 in. Stand Pipes, 5 in. at bottom, 4 in. at top. Bridge and Dip Pipes, 4 in. Address DAYTON GAS LIGHT AND COKE CO., 120 East Third Street, Dayton, Ohio. 783-tf

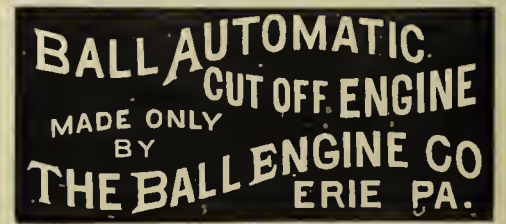

The New York Oxygen Co., No. 80 Broadway,

Are prepared to give full information on the application of Oxygen to the purification of lighting gas.

Simpkin & Hillyer

RICHMOND, VA.

MANUFACTURERS OF

Gas Works Apparatus

BENCH CASTINGS, CONDENSERS,

Scrubbers, Purifiers, Dry Center Seals,

FOUR-WAY VALVES, GAS VALVES,

SULPHATE OF AMMONIA APPARATUS, TANKS, ENGINES, BOILERS, PUMPS, ETC., ETC.

Plans, Specifications and Estimates furnished for new works, or alteration of old works. Correspondence solicited. Works, Newport News, Va.



Bartlett Street Lamp Mfg. Co

MANUFACTURERS OF

Globe Lamps,

FOR

Streets, Parks, Public Buildings, Railroad Stations, etc.

LAMP POSTS

A Specialty.



Office and Salesroom, 40 & 42 COLLEGE PLACE, - - N. Y. CITY.

Gas Companies and others intending to erect Lamps and Posts will do well to communicate with us.

MOSES G. WILDER, MECH. ENGR.

816-18-20-22 Cherry St., Phila., Pa.

Volumetric Lamp Governors

FOR GAS LAMPS & HIGH-POWER BURNERS.

GOVERNOR BURNERS

for

STREET LAMPS AND GENERAL USE,

and

GOVERNORS FOR ARGAND AND OTHER COMMON GAS BURNERS IN ALL SIZES.

HORIZONTAL

Governors

Specially adapted for GAS STOVES, FURNACES,

Etc., Etc.

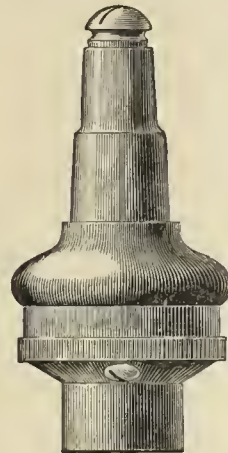

It is well known that a large majority of all High Power Gas Lamps in the United States have my Governors attached, and they are always used by the leading makers of these lamps. To remove any excuse for the use by anyone of inferior and infringing Governors, a reduction in price has been made, and all exclusive contracts are cancelled.

Correspondence Solicited with all who require a Reliable Governor.

Fuel and Its Applications.

By E. J. MILLS, D.Sc. F.R.S., and F. J. ROWAN, C.E., assisted by others, including Mr. F. P. Dewey, of the

Smithsonian Inst., Wash., D. C.

7 PLATES, AND 607 OTHER ILLUSTRATIONS. ROYAL OCTAVO, PAGES xx, 802. HANDSOME CLOTH, \$7.50.

A. M. CALLENDER & CO., 42 Pine St., N. Y.

GASHOLDER PAINT.

Use Only

THE GOVERNMENT WATERPROOF PAINT.

Proof against Ammonia, and Absolutely Waterproof. Send for Prices and Particulars.

THE GOVERNMENT WATERPROOF PAINT CO., 122 Milk Street, Boston, Mass.

FRIEDRICH LUX,

Ludwigshafen am Rhein and London.

Lux Mass

GAS GOVERNORS,

Gas Balance.

FORT WAYNE ELECTRIC CO.

FORT WAYNE, IND.

MANUFACTURERS OF THE

Slattery Induction System

—OF—

LONG DISTANCE INCANDESCENT LIGHTING.

The Most Carefully Worked Out and Complete Alternating Current System of Electric Lighting in Existence.

—AND THE—

WOOD

Automatically Regulating
ARC DYNAMOS and LAMPS.

Main Office, - - - Fort Wayne, Indiana.

Factories: Fort Wayne, Ind.; Brooklyn, N. Y.

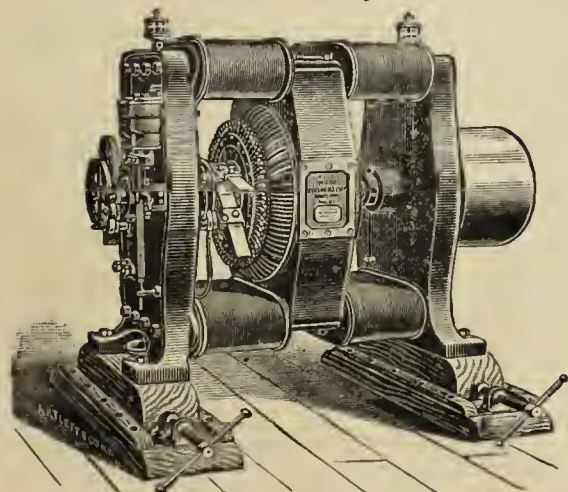

Wood Dynamo.

BRANCH OFFICES.

NEW YORK, - - - - -	115 Broadway.
PHILADELPHIA, - - - - -	907 Filbert Street.
CHICAGO, - - - - -	185 Dearborn Street.
SAN FRANCISCO, - - - - -	35 New Montgomery Street,

DETROIT, MICH., - - - - -	57 Gratiot Avenue.
TORONTO, CANADA, - - - - -	138 King Street, West.
MEXICO, F. Adams' Successors, - - - - -	City of Mexico.
CUBA, Maicas & Co., - - - - -	Havana?

The Gordon Portico Lamp.

A successful Competitor of the Arc Electric Light for lighting Store Fronts, Show Windows, Depots, Railway Sheds, etc., etc.

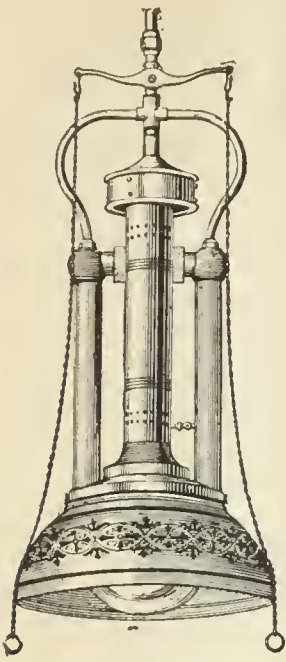

Gordon Portico Lamp.

The Gordon Street Lamp.

A Successful Competitor of the Arc Electric Light for lighting Streets, etc., etc.

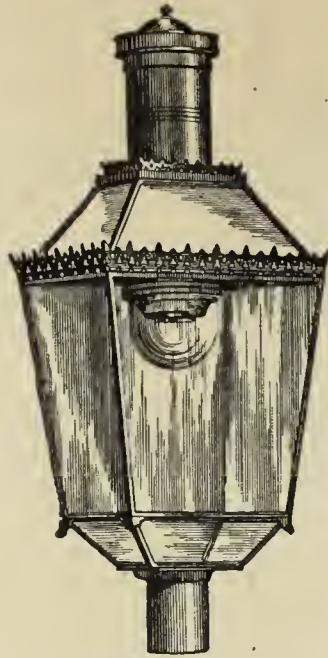

Gordon Street Lamp.

The Lungren Lamp.

A Successful Competitor of the Incandescent Electric Light for Interiors, etc. Is especially applicable for the lighting of Offices, Stores, Factories, Mills, Show Windows, Libraries, and all situations where an increased illumination is desired.

More than 25,000 Lungren Lamps are now in use. Testimonials, references, or any desired information will be cheerfully given.

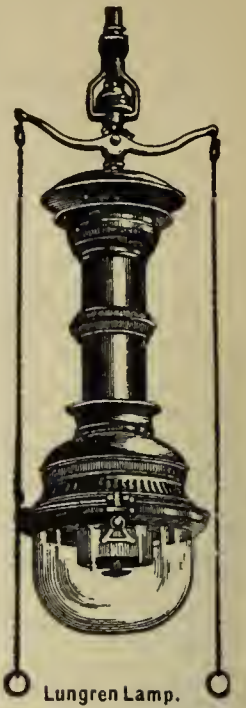

Lungren Lamp.

THE SIEMENS-LUNGREN CO., N.E. Cor. 21st St. & Washington Av., PHILADELPHIA.

WELSBACH SYSTEM OF Incandescent Gas Lighting.

OFFICE, DREXEL BUILDING, PHILA., PA.

At the Fall Session of the Board of Supervisors of Winnebago County, held at the County Court House, Oshkosh, Wis., Nov. 26, 1889, the report submitted by Mr. C. W. Cook, Chairman of the Committee on Public Buildings, recommending the use of the Welsbach Incandescent Gas Burner in the Buildings under their charge, was unanimously adopted, because of the extreme economy in the consumption of Gas and the superior character of the light obtained.

CHARLES E. DICKEY.

JAMES B. SMALLWOOD.

CHARLES H. DICKEY.

THE MARYLAND METER AND MANUFACTURING CO.

Established 1866.

BALTIMORE, North & Saratoga Sts.

CHICAGO, 197 Michigan Street.

NEW YORK, 766 Broadway.

BOSTON, 4 Central Street.

ST. LOUIS, 1115 Olive Street.

SAN FRANCISCO, 330 Pine Street.

CONSUMERS' & STATION METERS, PRESSURE GAUGES, Etc., Etc.

"Success" and "Perfect" Gas Stoves.

EDGEWATER LIME WORKS

Chas. F. McKenna, Proprietor.

SHELL LIME.

Lime by the Cargo for Gas Purification.

EDGEWATER, BERGEN CO., N. J.

Write for Testimonials and Prices.

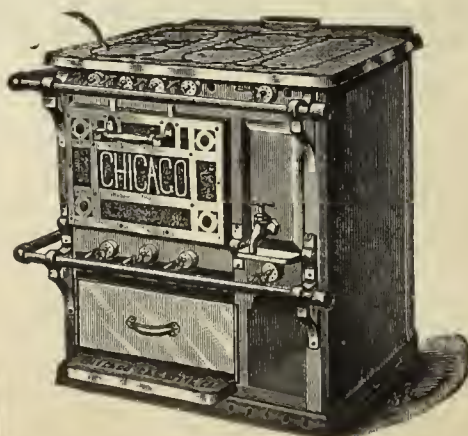

CHICAGO GAS STOVE CO.

MANUFACTURERS OF ALL KINDS OF

Gas Cooking and Heating
APPLIANCES.

117-119 Lake St., CHICAGO,

Send for Catalogue.

JEWEL GAS STOVES



Are Best,

BECAUSE THEY ARE

HIGH GRADE,

Interchangeable,

RIGHT!

WE USE NO GAS COCKS.

All Flames are Regulated by Direct Needle Valves.

JEWEL CIRCULATING WATER HEATER.

No. 510, - - - - \$15.00.

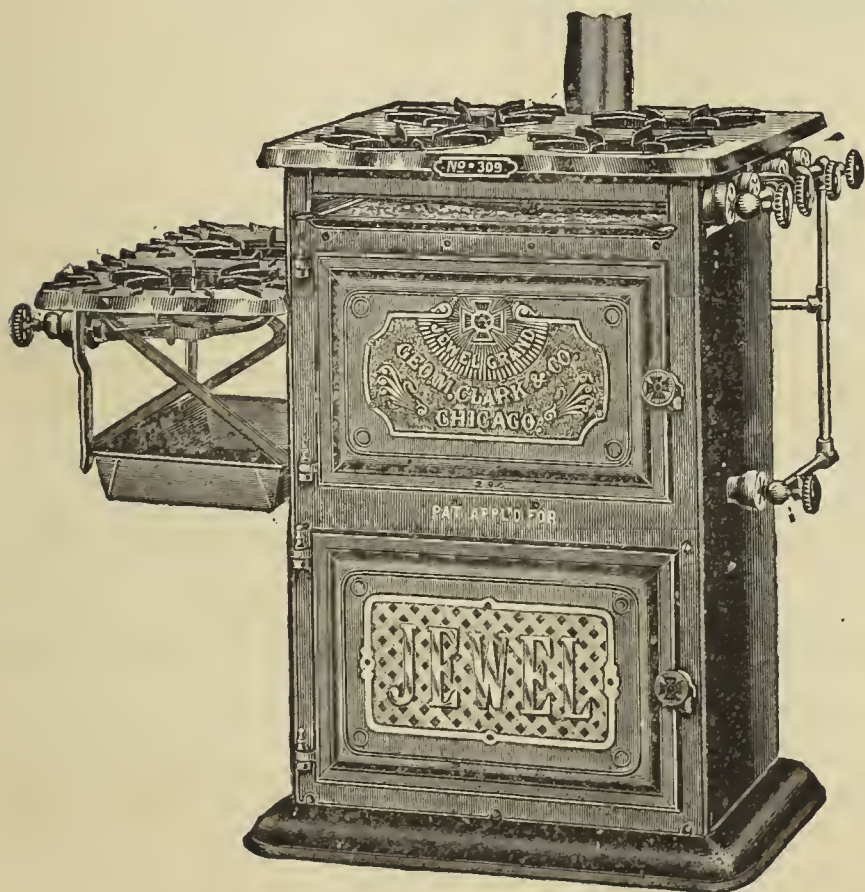

Write for Jewel 1890
Catalog.

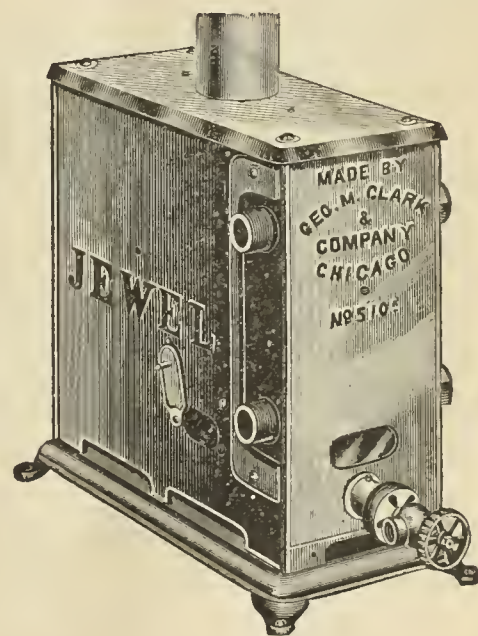

GEORGE M. CLARK & COMPANY,

MANUFACTURERS,

157 & 159 Superior Street, - - - Chicago, Ill.

NATIONAL GAS LIGHT AND FUEL CO.,

218 La Salle Street, Chicago.

C. D. HAUK, Prest. & Gen'l Manager.

A. W. GREEN, Vice-Prest.

N. A. McCLARY, Sec. & Treas.

E. E. MORRELL, Engr.

GAS WORKS

Built, Remodeled, Leased, and Purchased.

71 Springer Cupolas
have been installed
in the U. S. during
the past four years.

The total capacity of
Springer Apparatus
now in use is over
25,000,000 ft. daily.

THE SPRINGER CUPOLA SYSTEM

Has Proven Itself the most Economical and Satisfactory Method of Gas Manufacture ever brought to the attention of the Gas Fraternity.

GUARANTEED ESTIMATES of Cost of Gas Furnished on Application.

GASHOLDER TANK CONSTRUCTION, ETC.

Gas Companies and others about to erect Gasholders will find it profitable to consult W. C. Whyte, who for over 30 years has made a specialty of

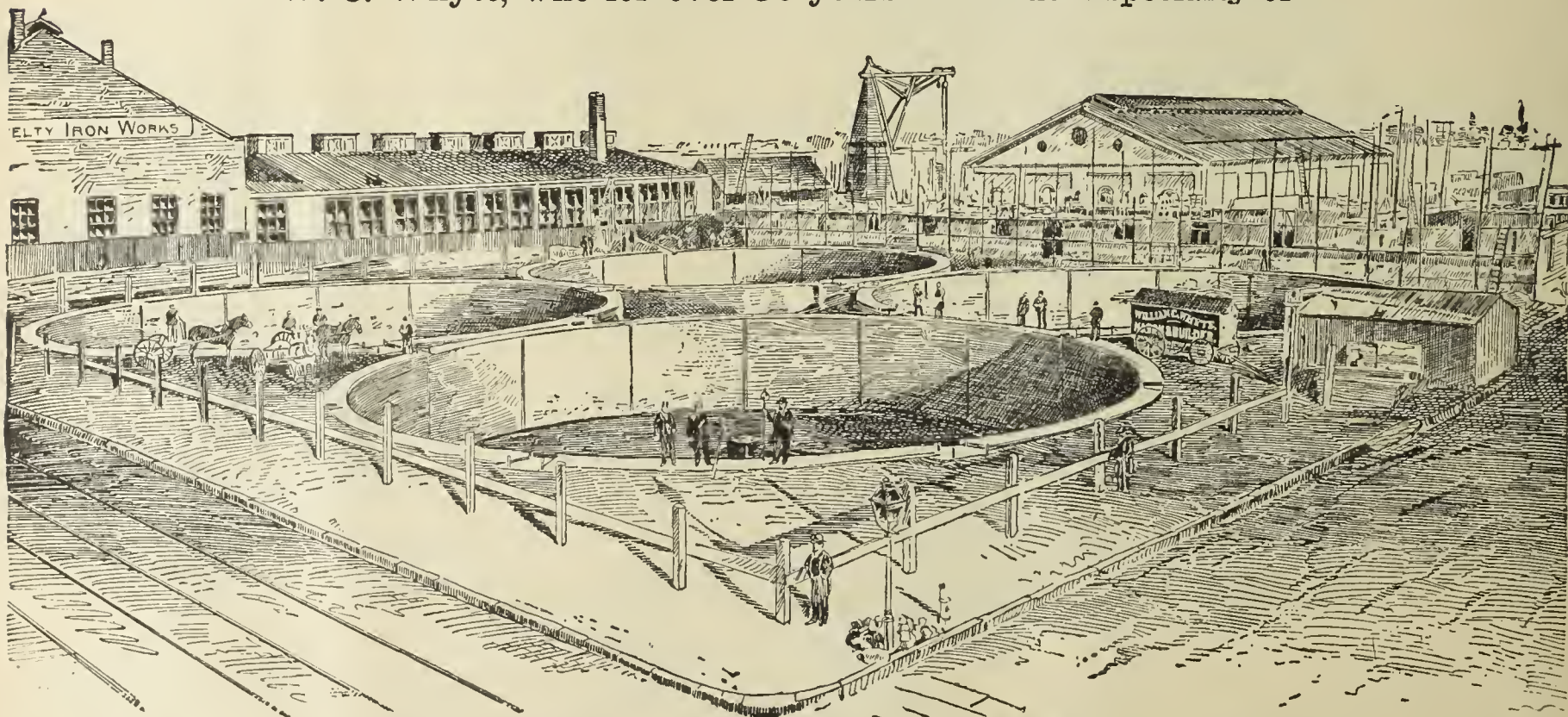

Tank Excavation and Mason Work.

Fifty Tanks now in operation show the sort of work done. Address

W. C. WHYTE, - No. 15 Cortlandt Street, N. Y. City.

GAS STOVES.

GAS METERS.

GAS STOVES.

THE AMERICAN METER CO.

Established 1834.

Incorporated 1863.

MANUFACTURERS OF

Gas Meters,

STATION METERS,

METER PROVERS, PHOTOMETERS,

Pressure Gauges of all Kinds,

AND



Standard 3 Diaphragm Dry Meter.



Standard 2 Diaphragm Dry Meter.

Apparatus for Testing the Quantity and Quality of Gases.

GAS STOVES FOR HEATING AND COOKING.

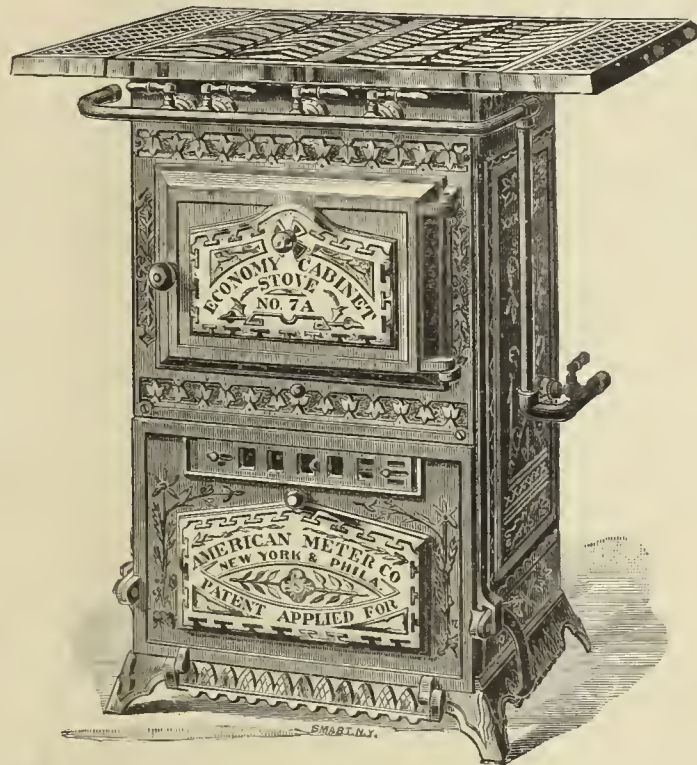

Circulars and Price Lists on Application.

MANUFACTORIES,

508 to 514 West Twenty-second St., N. Y.

Arch and Twenty-second St., Phila.

Nos. 244 & 246 North Wells Street, Chicago, Ill.

AGENCIES,

No. 177 Elm Street, Cincinnati, Ohio.

No. 222 Sutter Street, San Francisco, Cal.

No. 810 North Second Street, St. Louis, Mo.

GAS STOVE SHOW ROOMS, No. 242 Sixth Avenue, New York City.

THE WALKER TAR AND CARBONIC ACID EXTRACTOR.

A very general demand exists, in both large and small Gas Works, for an apparatus that will be absolutely efficient in the removal of the tar which passes the hydraulic main and condenser. Many attempts have been made to accomplish this, but, I believe, without success, until the introduction, five years ago, in England, of the C. & W. Walker Patent Tar and Carbonic Acid Extractor. During these years this apparatus has been adopted by many of the most prominent Engineers, not only in England, but also on the Continent of Europe and in other parts of the world. It is only necessary to give here a partial list in order to convince any intelligent American Gas Engineer that this machine must have succeeded fully in accomplishing the desired results.

The following Engineers have personally given permission to refer to them:

G. C. Trewby, Esq., Engineer-in-Chief of the Gas Light and Coke Co., London. The manufacturing plant at Beckton is built in complete sections of 3,000,000 cubic feet capacity each. A Walker Tar Extractor has been fitted to each one of these sections. This was done after a long and thorough trial on one of its sections. The Tar Extractor has been supplied to other works of the Gas Light and Coke Co., including those of which John Methven, Engineer of the Gas Light and Coke Co. at the Nine Elms Station, is in charge. Also to G. E. Stevenson, Peterborough Gas Works; B. Green, Mitcham and Wimbledon Gas Works; W. H. Smith, Bedford Gas Works; F. Linging, Norwich Gas Works; J. T. Browning, Colchester Gas Works; S. B. Darwin, Portsmouth Gas Works; J. McCrae, Dundee Gas Works; W. J. Wells, Stamford Gas Works; J. M. Darwin, Longton Gas Works; J. Paterson, Warrington Gas Works; and J. Coulter, of the Dundalk Gas Works. All of the foregoing gas works are located in Great Britain.

Mr. Charles A. Gerdenier, Superintendent of the Bridgeport (Conn.) Gas Light Company, writes as follows, under date of Dec. 3, 1887:

"The C. & W. Walker Tar and Carbonic Acid Extractor has been in operation at these works for the past six weeks, and is an unqualified success. It removes every particle of Tar from the gas in once passing through the apparatus, and a large percentage of the Carbonic Acid. I also feel quite sure that it prevents the formation and deposit of Naphthaline, because since I started the Washer I have had no stoppages from this cause. These works have been seriously troubled with Tar for many years, and I have used several kinds of apparatus and every expedient which has come to my attention for dealing with the difficulty, but without success. The Walker apparatus occupies comparatively small space, is less expensive than other systems, and requires but little attention. I carry 2½-inch seal, and have an automatic tar delivery valve. This Tar Extractor is indispensable to gas makers."

I have taken the Agency for the United States for this apparatus, and am now prepared to make contracts to erect it on the premises of any Gas Company. It would be manufactured in the following sizes:

No. 1,	50,000 to	100,000	cu. ft. per	24 hrs.,	3 ft. square,	5 ft. deep.			
No. 2,	"	"	125,000	"	"	"	4	"	"
No. 3,	"	"	250,000	"	"	"	5	"	"
No. 4,	"	"	500,000	"	"	"	6	"	"
No. 5,	"	"	750,000	"	"	"	7	"	"
No. 6,	"	"	1,000,000	"	"	"	8	"	"
No. 7,	"	"	1,250,000	"	"	"	9	"	"
No. 8,	"	"	1,500,000	"	"	"	10	"	"
No. 9,	"	"	2,000,000	"	"	"	12	"	"
No. 10,	"	"	3,000,000	"	"	"	15	"	"

This Tar Extractor will perform its work with about one-fourth the usual back-pressure heretofore required. It is simple in construction, and can be supplied at a very reasonable price—less than any other ever before introduced. Satisfactory results will be guaranteed in every instance.

GEO. SHEPARD PAGE,

SOLE AGENT FOR THE UNITED STATES,

No. 69 Wall Street, - - - New York.

THE UNITED GAS IMPROVEMENT CO.,

DREXEL BUILDING, PHILA., PA.

Owners of the Lowe, Granger-Collins, McKay-Critchlow (for carbureting Natural Gas), and Other Gas Patents.

BUILDERS, LESSORS *and* PURCHASERS OF GAS WORKS.

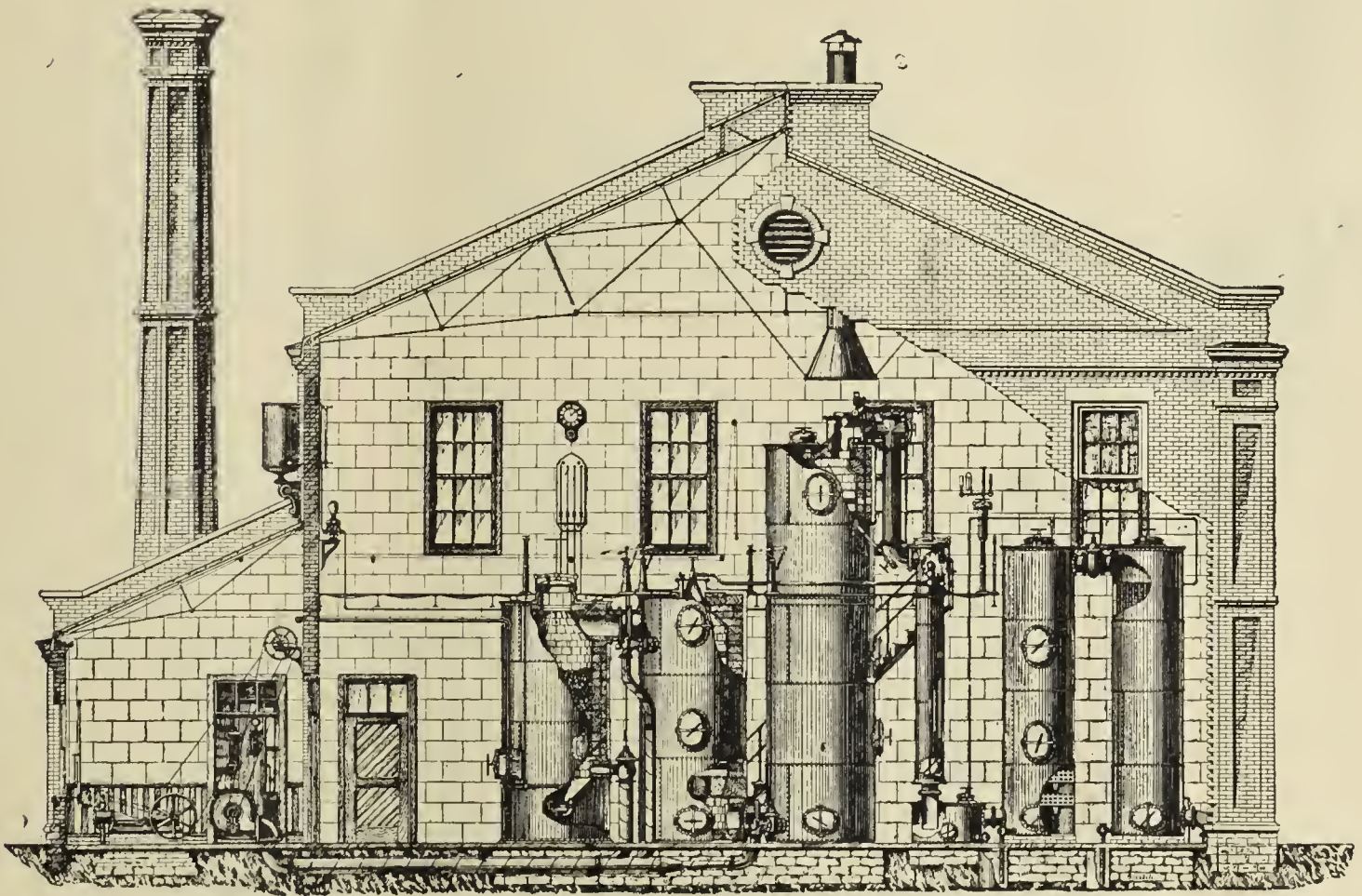

Standard "Double Superheater" Lowe Apparatus, Especially Designed for the Use of Lima Crude Oil.

Erectors of

WATER GAS PLANTS,

(Either Independent or Auxiliary to Coal Gas Works),

USING LIMA OR OTHER LOW GRADE OILS AND ANTHRACITE COAL OR GAS HOUSE OR OVEN COKE.

PAMPHLETS, PLANS, AND ESTIMATES FURNISHED UPON APPLICATION.

ROOTS' GAS AND BYE-PASS VALVES.

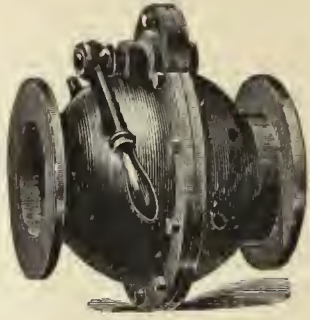

GAS VALVE

Quick Acting,
Simple,
Efficient, Durable.

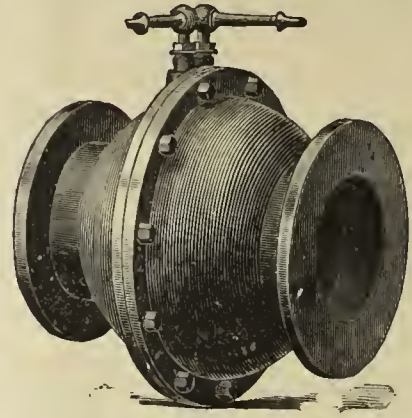

BYE-PASS VALVE.

Automatic Action
Reliable
Simple Durable.

Thousands now in use and giving perfect satisfaction. Write for Catalogue and Prices.

ROOTS' NEW GAS EXHAUSTER.

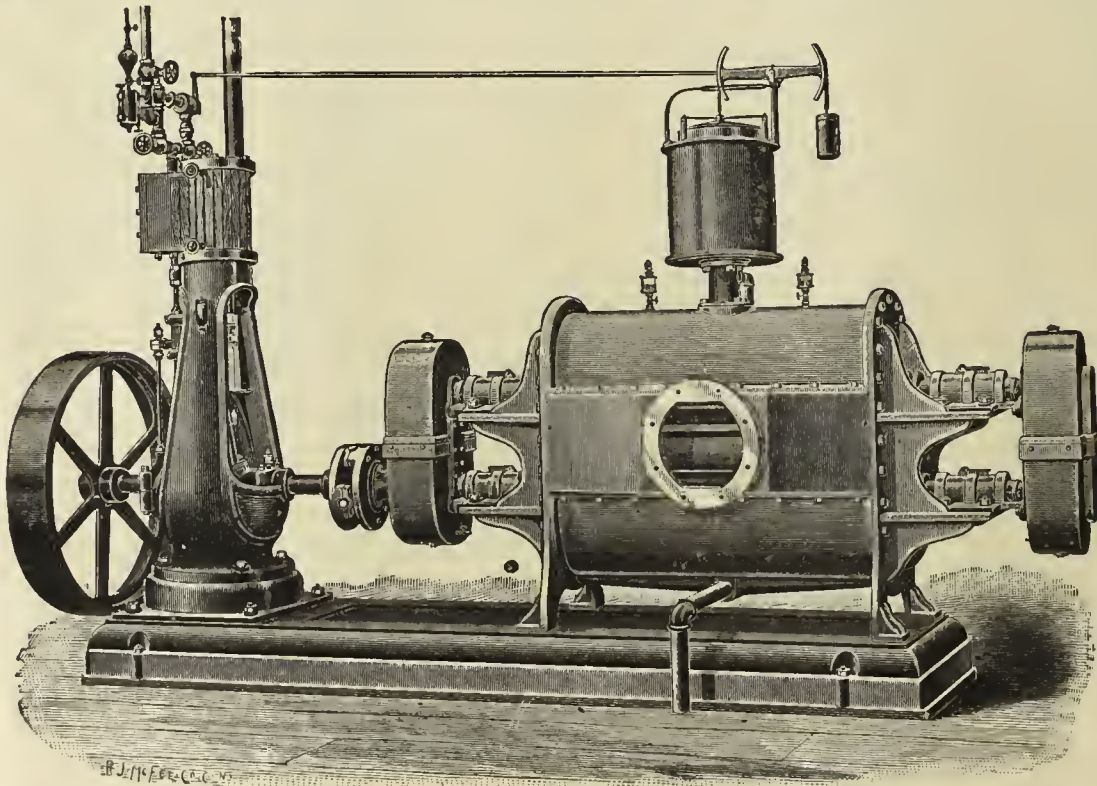

UNSURPASSED FOR

Neatness of Design, Durability, Simplicity, Efficiency, and Economy of Power.

THE ONLY EXHAUSTER MADE WHERE

The Parts Needing Attention are External, and Easily Accessible.

Send for Descriptive Catalogue and Price List.

THE P. H. & F. M. ROOTS CO., Patentees and Manufacturers, **CONNERSVILLE, IND.,**

S. S. TOWNSEND, Gen. Agt., 22 Cortlandt St., N. Y. COOKE & CO., Selling Agts., 22 Cortlandt St., N. Y.

CONNELLY & CO.,

SOLE MANUFACTURERS OF THEIR PATENTED SPECIALTIES.

"IRON SPONGE."

Saves money, saves labor, and is the most efficient purifying agent ever offered as a substitute for lime. Now used *in every State in the Union*, and purifying daily over *thirty-five million cubic feet*. Should be used in every gas works. Its own saving will pay for it many times over.

AUTOMATIC GOVERNOR.

Has been on the market but *three years*, and in that time has been introduced *more generally* than any invention ever designed for use in gas works. Over *two hundred* of them now in use. Sensitive; reliable; perfectly automatic; reduces leakage; satisfies consumers, and gives great relief to the Manager. No gas works is *complete* without one of these machines.

STEAM JET EXHAUSTER.

Designed particularly for small works. Combines Exhaust Tube, Steam Governor Gas Compensator, and Bye-Pass Valves in the most compact form possible; occupies but little space; uses very little steam; operated by ordinary workmen; saves formation of carbon in retorts; increases yield 10 to 15 per cent. Specially adapted for *mixing air* with oil gas. *No works* too small to use them profitably.

Prices given on all our specialties *delivered at any point in the United States*. Correspondence solicited.

CONNELLY & CO., No. 111 Broadway, New York City.

WILBRAHAM GAS EXHAUSTER & ENGINE COMBINED.

WILBRAHAM BROS.,
PHILADELPHIA, PA.

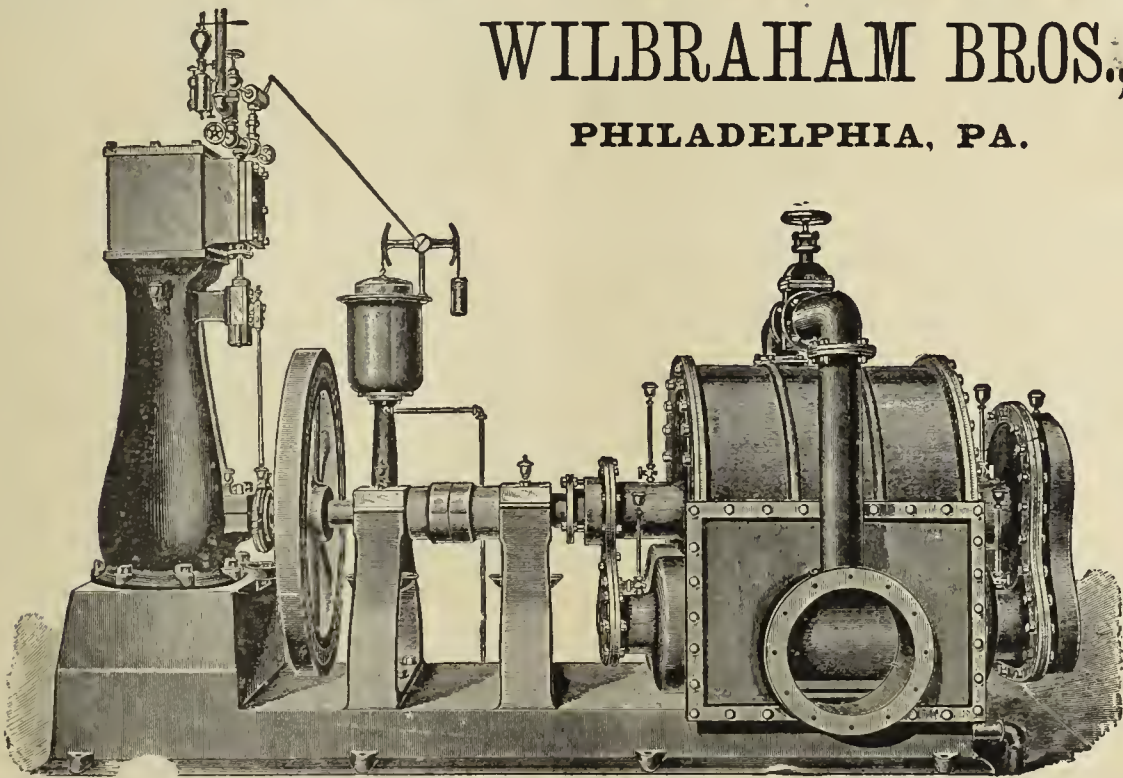

JARVIS ENGINEERING CO.,

61 Oliver St., Boston, Mass.

CONTRACTORS FOR ERECTING

COMPLETE STEAM OUTFITS FOR ELECTRIC LIGHTING STATIONS.

Steel Boilers set with Jarvis Pat. Boiler Setting

To burn **COKE SCREENINGS** for Fuel.

ARMINGTON & SIMS CO. ENGINES,

Belting direct to Dynamos, without using Shafting.

SEND FOR CIRCULARS.

REFERENCES.—Charlestown Gas & Electric Light Co., Charlestown, Mass.; Schenectady Gas & Electric Light Co., Schenectady N. Y.; Brookline Gas Co., Brookline, Mass.

Practical Electric Lighting

By A. BROMLEY HOLMES, A.M.I.C.E.

With 87 Illustrations. Third Edition. Price, \$1.00.

Electric Light Primer.

By CHARLES L. LEVEY.

A simple and comprehensive Digest of all the most important facts connected with the running of the Dynamo and Electric Lights, with Precautions for Safety, etc.

Price, 50 cents.

A. M. CALLENDER & CO., 42 Pine St., N. Y.

Gasholder Tanks & Gas Works Masonry Complete.

PLANS PREPARED AND ESTIMATES FURNISHED AT SHORT NOTICE.

J. P. WHITTIER, 70 Rush St., near Division Av., Brooklyn, N. Y.

1890 DIRECTORY 1890

OF THE GAS LIGHT COMPANIES of the UNITED STATES & CANADA.

Price, \$5.00.

A. M. CALLENDER & CO., No. 42 Pine Street, N. Y. City.



CHAPMAN VALVE MANUFACTURING CO.,

MANUFACTURERS OF

Valves and Gates for Gas, Ammonia, Water, Etc.

Also, Gate Fire Hydrants With and Without Independent Nozzle Valve. All Work Guaranteed.

WORKS & GEN'L OFFICE:
Indian Orchard, Mass.

TREASURER'S OFFICE:
72 Kilby & 112 Milk Sts, Boston, Mass.

LUDLOW VALVE MFG. CO.

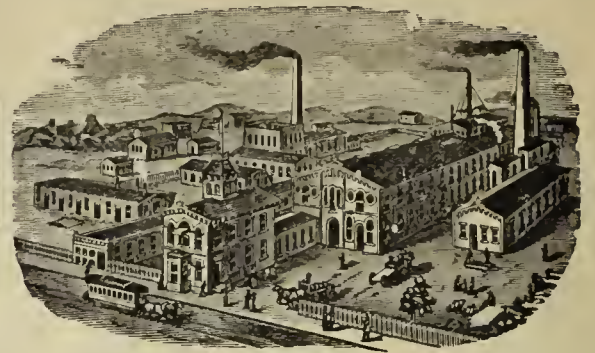

OFFICE AND WORKS,

938 to 954 River Street and 67 to 83 Vall Av.,
TROY, N. Y.

Parson's Steam Blower,

FOR IMPROVING BAD DRAUGHT IN BOILERS, AND FOR BURNING BREEZE OR OTHER WASTE MATERIAL.

PARSON'S TAR BURNER,

FOR UTILIZING COAL TAR AS FUEL.

PARSON'S AIR JET TUBE CLEANER,

FOR CLEANING BOILER TUBES.

These devices are all first-class. They will be sent to any responsible party for trial. No sale unless satisfactory. Manufactured by the WATERTOWN STEAM BLOWER COMPANY.

H. E. PARSON. Supt., 33 & 35 Liberty St., N.Y

MILLS' REVERSIBLE LIME TRAY,

AND

WOODWORK

Of Every Description

NEEDED BY GAS WORKS.

SEND FOR CIRCULAR AND PRICE LIST TO

BARTLETT, HAYWARD & CO.,

Pratt and Scott Streets, Baltimore, Md.

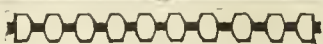
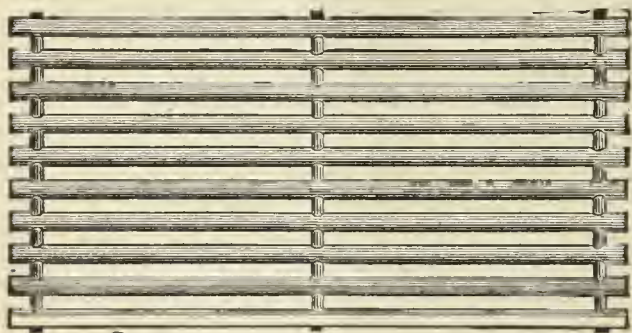

VAN DUZEN GAS & GASOLINE ENGINE

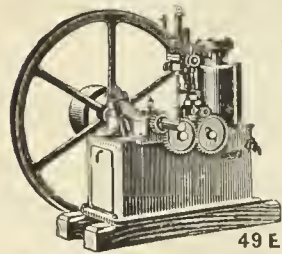

OPERATED with COAL and OTHER MANUFACTURED GASES AND GASOLINE.

RELIABLE AND ECONOMICAL.
Fully Warranted

VAN DUZEN Gas & Gasoline Engine Co.
49 E. 2d St., Cincinnati, O.

A. MacKinnon Machine Co., Agts., 22 Warren St., N.Y.

The Management of Small Gas Works.

BY C. J. R. HUMPHREYS.

Price, \$1.

Orders to be sent to A. M. CALLENDER & CO.,

42 PINE STREET, NEW YORK.

Hydraulic Main Dip Regulators, also Check Valves, Foot Valves, Yard-wash and Fire Hydrants.
Send for Circulars.

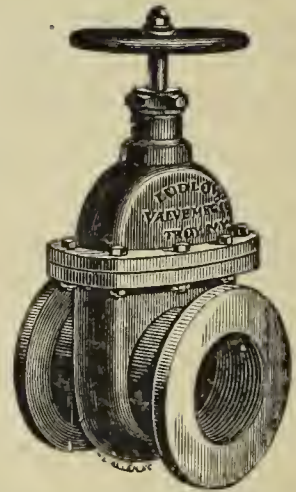

Valves.—Double and Single Gate, 1/2 in. to 48 in., outside and inside Screws. Indicator, etc., for Gas, Water, Steam, and Oil.
Send for Circulars.

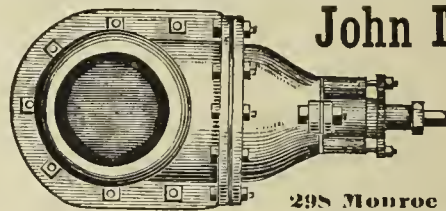

John McLean

Manufacturer

GAS VALVES.

298 Monroe Street, N. Y.

SPECIAL TRAYS FOR IRON SPONGE OR OXIDE OF IRON.
CHURCH'S TRAYS A SPECIALTY.

REVERSIBLE—STRONGEST—MOST DURABLE—MOST EASILY REPAIRED.

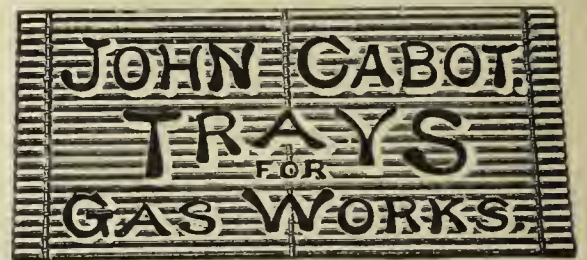

306-310 ELEVENTH AVENUE, NEW YORK.

WE ALSO MAKE THE CHEAPEST AND STRONGEST REVERSIBLE BOLTED TRAYS IN THE MARKET.

THE CLERK GAS ENGINE CO.,

Main Office, 1012, 1014, 1016, 1018 Filbert St., Philadelphia, Pa.

WM. W. GOODWIN, Prest.

E. STEIN, Sec.

S. LEWIS JONES, Asst. Sec.

A. J. DOTY, Supt.

The utility and convenience of the Gas Engine being no longer an open question, it only remains now for intending purchasers to select the BEST. We claim for the CLERK GAS ENGINE that it is equal to any other manufactured as regards steadiness in running, simplicity, and ease of keeping in repair, and that it gives the greatest amount of power for the least money (both in first cost and expense of running) of any engine made. In support of this claim we refer to the test of the Gas Engines made under the direction of the American Institute of New York, in December, 1885, and heretofore published in these columns. These engines are especially adapted for continuous running under heavy loads, and we can refer to Engines which have run 22 hours a day for months at a time

Made in Sizes of 5, 10, 15, 20, and 25 Horse Power. All Engines Guaranteed for One Year.

ENGINEERS.

P. D. WANNER, Chairman. A. H. MELLERT, Mangr. of Wks.
R. B. KINSEY, Secretary. F. A. KNOPP, Treasurer.

MELLERT FOUNDRY & MACHINE CO. Ltd.
and **READING FOUNDRY CO., Ltd.**
Reading, Pa.



Specials—Flange Pipe, Valves and Hydrants
Lamp Posts, Retorts, etc.
General Foundry and Machine Work.
JOHN FOX, Selling Agent. 160 Broadway, N. Y.

THE OHIO PIPE COMPANY,

MANUFACTURERS OF

Cast Iron Gas & Water Pipe,

BRANCH AND SPECIAL CASTINGS.

Gas-House Bench Castings, Hydraulics, Lamp Posts, Flange Pipe
and Specials, Architectural Castings, Building Columns,
Joists, Cellar Grates, Sash Weights, etc.

GENERAL FOUNDERS AND MACHINISTS.
Columbus, Ohio.

M. J. DRUMMOND,



SPECIAL CASTINGS AND LAMP POSTS.
Office, Corbin Building, 192 Broadway, N. Y.

EMAUS PIPE FOUNDRY.

DONALDSON IRON COMPANY. EMAUS, PA.



MANUFACTURERS OF

CAST IRON PIPE AND SPECIAL CASTINGS
FOR WATER AND GAS.

JOS. R. THOMAS,

No. 42 Pine Street, N. Y. City.

CONSULTING AND CONSTRUCTING
Gas Engineer and Contractor.

PLANS, SPECIFICATIONS, AND ESTIMATES
FURNISHED.

Contracts taken for all Appliances
required at a Gas Works,
Either for New Works or Extensions to Old Plants.

WM. MOONEY

(Successor to WM. FARMER)

No. 94 Liberty St., N. Y. City.

GAS ENGINEER AND CONTRACTOR FOR THE ERECTION
OF GAS WORKS, OR APPARATUS OF ANY
CAPACITY.

Plans and Specifications Furnished.

WM. GARDNER,
Gas Engineer,

Lewis Block, Room 20, Pittsburgh, Pa.

Those who intend to make alterations in existing gas plants, or
who contemplate the erection of new works, will find to their
interest to open correspondence with the above. Plans made
and estimates furnished.

GAS AND WATER PIPES.

SAM'L R. SHIPLEY, Pres.
HENRY B. CHEW, Tre.

GLOUCESTER IRON WORKS,
GLOUCESTER CITY, N. J.



JAS. P. MICHELLON, Sec.
WM. SEXTON, Supt.

Cast Iron Gas & Water Pipes, Stop Valves, Fire Hydrants, Gasholders, &c.

Office, Rooms 61 and 63 Bullitt Building, 131 S. 4th St., Phila., Pa.

WARREN FOUNDRY AND MACHINE CO.,

Established 1856. Works at Phillipsburgh, N. J.

New York Office, 160 Broadway.

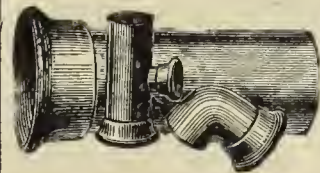

CAST IRON WATER AND GAS PIPE,

FROM TWO TO FORTY-EIGHT INCHES DIAMETER. ALSO, ALL SIZES OF

Flange Pipe for Sugar House and Mine Work. Branches, Bends, Retorts, etc., etc.

DENNIS LONG & COMPANY,

LOUISVILLE, KY.,



Manufacture Exclusively

CAST IRON GAS & WATER PIPE & SPECIAL CASTINGS
OF ALL SIZES.

King's Treatise on Coal Gas.

A standard text-book for the Engineers and Managers of Gas Works, and for all who are concerned
or take an interest in the manufacture and distribution of Coal Gas, and in the utilization of the
Secondary Products resulting therefrom; treating also of the Gas Engine, and of Gas Cooking and
Heating Appliances.

In 3 Vols. Price per Vol., \$10. Sold either by Volume or in Sets.

A. M. CALLENDER & CO., 42 Pine St., N. Y.

RETORTS AND FIRE BRICK.

J. H. GAUTIER & CO.,

CORNER OF

GREENE AND ESSEX STREETS,

JERSEY CITY, N. J.

MANUFACTURERS OF

Clay Gas Retorts,**Gas House Tiles,****Fire Bricks, Etc. Etc.**

Ground Clay, Fire Brick and

Fire Sand in Barrels,

J. H. GAUTIER. C. E. GREGORY. C. E. GAUTIER.

BROOKLYN**Clay Retort & Fire Brick Works,**

(EDWARD D. WHITE & CO.)

Manufacturers of Clay Retorts, Fire Brick,

Gas House and other Tile.

VAN DYKE, ELIZABETH, RICHARDS & PARTITION STS.

Office, 88 Van Dyke St., Brooklyn, N. Y.

RETORTS AND FIRE BRICK.

LACLEDE FIRE BRICK MFG. CO.,

MANUFACTURERS OF

Fire Brick, Gas Retorts,

AND

ST. LOUIS STANDARD SEWER PIPE.

Blast Furnace and Cupola Linings, every description of Fire Clay Material, Fire Clay Flue Linings, Chimney Tops Dry Milled and Crude Fire Clays, etc.

OFFICE AND DEPOT

901, 903, and 905 Pine Street,

ST. LOUIS, MO.

ESTABLISHED IN 1845.

B. KREISCHER & SONS,

OFFICE FOOT OF HOUSTON ST., E. R., N. Y.

Gas Retorts,**TILES, FIRE BRICK.**

AND EVERYTHING IN THE FIRE CLAY LINE.

RETORTS AND FIRE BRICK.

MANHATTAN

FIRE BRICK & ENAMELLED CLAY

RETORT WORKS**ADAM WEBER.****CLAY GAS RETORTS**

AND RETORT SETTINGS

FIRE BRICKS, TILES, ETC.,

Office and Works, 15th Street and Avenue C., N. Y.

Works,
LOCKPORT STATION, PA.

—ESTABLISHED 1864.—

JAMES GARDNER, JR.,

Successor to WILLIAM GARDNER & SON.

Office, Rooms 19 & 20, Lewis Block,
PITTSBURGH, PA., P. O. Box 373.**Fire Clay Goods for Gas Works.**

H. A. NORTON, No. 4 CENTRAL STREET, BOSTON, MASS., Agent for the New England States.

GEO. C. HICKS,
Presl.**CHICAGO**CHAS. A. REED,
Sec. & Treas.**Retort and Fire Brick Co.,**

MANUFACTURERS OF

Fire Clay Goods of all Kinds,

AND BEST QUALITY ONLY.

Regenerative Furnaces & Water Gas Goods.

45th St., Clark to La Salle, Chicago.

GEROULD'S IMPROVED RETORT CEMENT.

A Cement for patching retorts, putting on mouthpieces, and making up all bench-work joints. This Cement is mixed ready or use. Economic and thorough in its work. Fully warranted or stick. For recommendations and price list address

C. L. GEROULD & CO.,

5 & 7 Skillman St., Brooklyn, N. Y.

Western Agent, H. T. GEROULD, Mendota, Ill.

**Parker-Russell
Mining and Mfg. Co.,**

CITY OFFICE,

Mermod-Jaccard Bldg., Rooms 307 & 308,
Broadway & Locust St., St. Louis, Mo.

PROPRIETORS OF THE

OAKHILL GAS RETORT & FIRE BRICK W'KS

Our immense establishment is now employed almost entirely in the manufacture of

Materials for Gas Companies

We have studied and perfected three important points. Our retorts are made to stand changes of temperature, the strongest heats of the furnace, and the abrasion of feeding and emptying. We have the exclusive Agency for the West of the celebrated

**Kloenne-Bredel Full Depth and
Semi-Recuperator Benches,**

And also furnish and build

Our Own Styles Semi-Recuperator Furnaces
for the use of Coal or Coke as fuel.

THOS. SMITH, Presl.

AUGUST LAMBLA, Vice-Presl. & Supt.

BALTIMORE**RETORT & FIRE BRICK CO.**

MANUFACTORY AT

LOCUST POINT BALTIMORE, MD.

Clay Retorts, Blocks & Tiles**FIRE BRICK, FIRE CLAY,
AND FIRE CEMENT.**Red and Buff Ornamental Tiles and Chimney
Tops. Drain and Sewer Pipe (from
2 to 30 inches). Baker Oven Tiles
12 x 12 x 2 and 10 x 10 x 2.

WALDO BROS., 88 WATER ST., BOSTON, MASS

Sole Agents the New England States.

Boston Fire Brick Works Manufacturers of **Gas Retorts and Settings**

Under the Personal Supervision of MR. GEO. C. HICKS late of Chicago.

Fire Clay Goods of all kinds. Akron Sewer Pipe, Lime, Cement, etc. Agts. for the Arc Gas Lamp & Governing Gas Burners.

Send for Circulars and Prices to

FISKE, COLEMAN & CO., Managers, No. 62 Congress Street, Boston, Mass.

FRED. BREDEL, C. E.,

Contractor for the Complete Erection and Equipment of Gas Works.

Sole Proprietor of the KLOENNE PATENTS for North America.

Gas Condensing and Purifying Machine.

Doing all the Work Between Exhauster & Oxide Purifier.

No Condensers Required.

No Naphthaline or Pitch is Formed.

HIGHER CANDLE POWER.

Tar & Ammonia Washers

WATER GAS WASHERS.

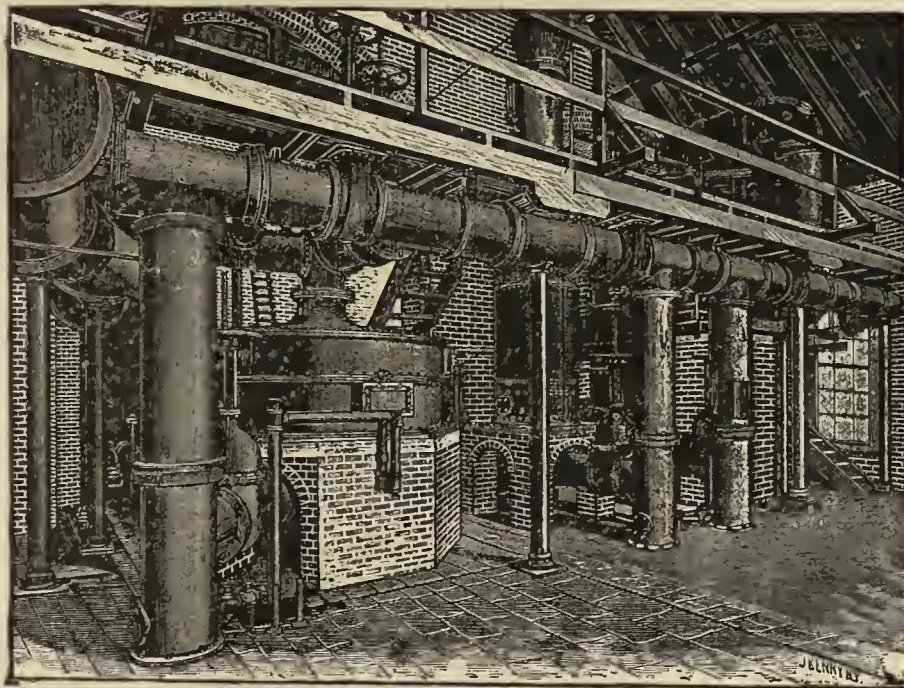

Purifying Machine erected at Cleveland Gas Works, No. 2. Capacity, 1,250,000 Cu. Ft.

RECUPERATIVE FURNACES.

Adapted to Retort Houses With or Without Stage Level.

Over 1,400 Retorts Now in Use in America.

Inclined Retort Benches.

Refers, by permission, to Mr. Eugene Vanderpool, Newark, N. J., and Mr. E. G. Cowdery, Milwaukee, Wis. For further information address

FRED. BREDEL,

No. 208 East Seventeenth Street, - - - New York City.

FLEMMING'S Generator-Gas Furnace

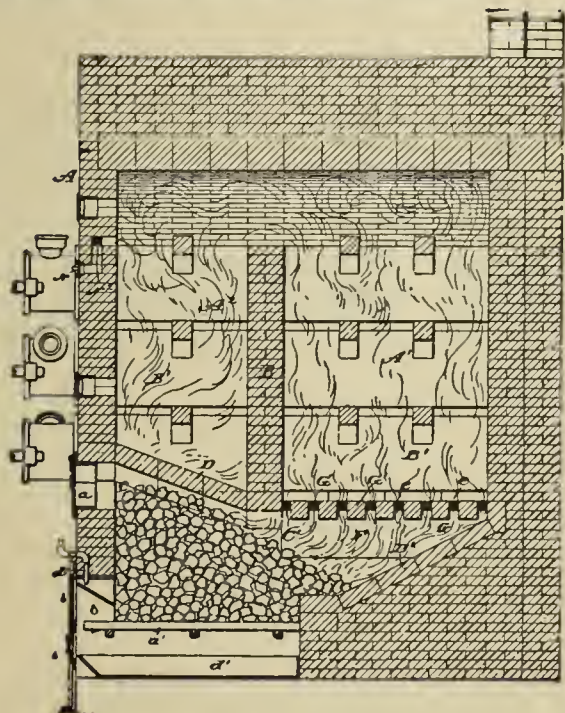

Materials furnished and Benches erected by

J. H. GAUTIER & CO., - Jersey City, N. J.

Address as above, or D. D. FLEMMING, Jersey City, N. J.

HENRY MAURER & SON,

(ESTABLISHED 1856.)

EXCELSIOR FIRE BRICK & CLAY RETORT WORKS

WORKS, Perth Amboy, N. J.

OFFICE, 418 to 422 East 23d St., N. Y.

Clay Gas Retorts,
BENCH SETTINGS,
Fire Brick, Tiles, Etc.

PATENTS.

FRANKLIN H. HOUGH

Solicitor of American & Foreign Patents.

925 F. ST., WASHINGTON, D. C.

(NEAR U. S. PATENT OFFICE.)

Personal attention given to the preparation and prosecution of applications for Letters Patent. All business before the U. S. Patent Office attended to for moderate fees. **No Agency in the United States possesses superior facilities for obtaining Patents,** or for ascertaining the patentability of inventions. Copies of patents furnished for 25 cents each. Correspondence solicited.

GREENOUGH'S

"DIGEST OF GAS LAW."

Price, \$5.00.

This is a valuable and important work, a copy of which should be in the possession of every gas company in the country, whether large or small. As a book of reference it will be found invaluable. It is the only work of the kind which has ever been published in this country, and is most complete. Handsomely bound. Orders may be sent to

A. M. CALLENDER & CO.,

42 Pine Street, N. Y.

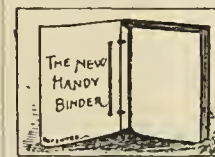

THE NEW HANDY BINDER.

This article may be described as elegant in appearance, strong, durable, and possessing many special qualities of its own. It allows the opening of the pages perfectly flat, whether one or several numbers are in the binder. Any number can be taken out and replaced without disturbing the others. The papers are not mutilated for subsequent binding in permanent form. The binder is supplied with gilt side tile, and is an ornament to any desk or reading table. The JOURNAL, filed in the Handy Binder, becomes a volume of great value, always convenient for instant reference. **Handy Binder, Postage paid, \$1 00.**

A. M. CALLENDER & CO., 42 Pine St., N. Y.

NEWBIGGING'S HANDBOOK FOR GAS ENGINEERS AND MANAGERS.

The present (the fifth) edition marks an important advance on those that have gone before. Considerable additions have been made to the text, and much of it has been rewritten and otherwise improved. Price, cloth, \$6. A. M. CALLENDER & CO., 42 Pine St., N. Y.

DAVIS & FARNUM MFG. CO.,

WALTHAM, MASS.

PRINCIPAL OFFICE AND WORKS, Waltham, Mass.

BOSTON OFFICE, Room 55, Mason Building, 70 Kilby Street.

SINGLE, DOUBLE,
AND
TRIPLE LIFT

Gas holders.

OF ANY CAPACITY.

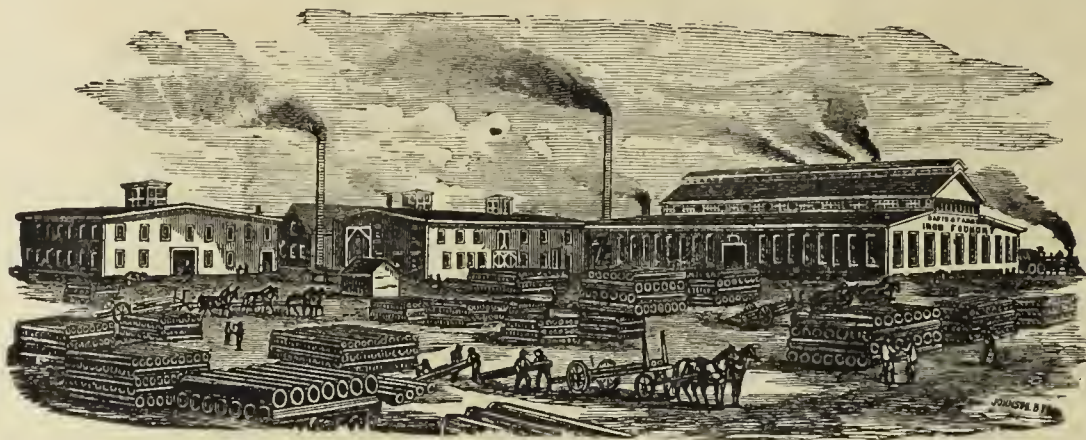

TUBULAR, PIPE,
AND
SINUOUS FRICTION

Condensers.

OF ALL SIZES.

IRON ROOF FRAMES AND FLOORS.

Purifying Boxes, Center Seal or Valve Connections, Bench Work.

Reversible Lime Trays.

SELF-SEALING AND PRESSED STEEL MOUTHPIECE LIDS.

Coke Barrows, Coal Wagons, and all Apparatus Requisite for a Complete Gas Plant.

— ALSO —

Gas and Water Pipe, Flanged Pipe,

Sugar House Work, and Special Castings of all Descriptions.

Established 1861.

Incorporated 1881.

KERR MURRAY MFG. CO.,

FORT WAYNE, IND.

Those who are in need of

Holdings or Gas Works Apparatus of any Description,

AND OF THE LATEST IMPROVEMENTS,

will find it to their interest to

GET AN ESTIMATE FROM US

before placing their order.

As we make a Specialty of this Class of Work, and are Practical Builders and Manufacturers of same,

with our long years of experience in the business,

WE CAN GUARANTEE YOU SATISFACTION.

Estimates, Plans and Specifications Furnished on Application.

BARTLETT, HAYWARD & CO.

Baltimore, Md.

Triple Double, & Single-Lift
GASHOLDERS.

Iron Holder Tanks.

ROOF FRAMES.

Cirders.

BEAMS.

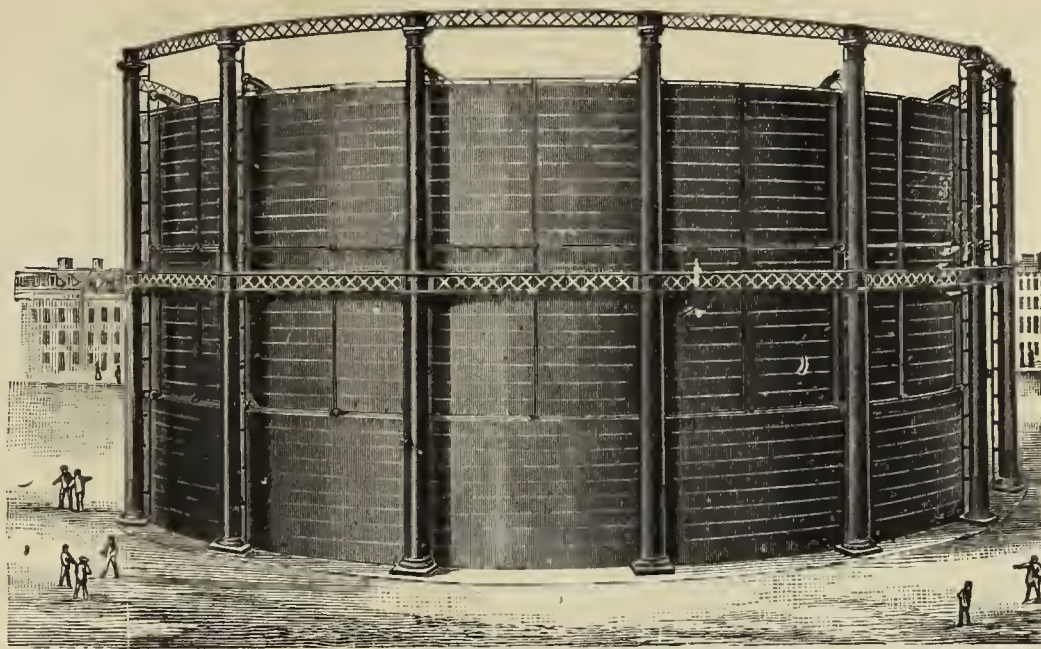

PURIFIERS.

CONDENSERS.

Scrubbers.

BENCH CASTINGS.

OIL STORAGE TANKS.

Boilers.

The Wilkinson Water Gas Process.

THIRTY-CANDLE, NON-CONDENSABLE, FIXED GAS. THE MOST SUCCESSFUL GAS PROCESS IN OPERATION.

Munich Regenerative Furnace, System Drs. Schilling & Bunte.

HAZELTON BOILERS.

Gas Works Designed and Constructed.

Pascal Iron Works. ESTABLISHED 1821. Delaware Iron Works.

MORRIS, TASKER & CO.,

INCORPORATED.

OFFICE, 224 SOUTH THIRD STREET, - - PHILADELPHIA, PA.

CONTRACTORS, BUILDERS, AND MANUFACTURERS OF

Gas, Water & Sugar Works

Bench Castings.

Condensers.

Scrubbers.

Purifiers.

Hyd. Carriages.

Iron Floors,

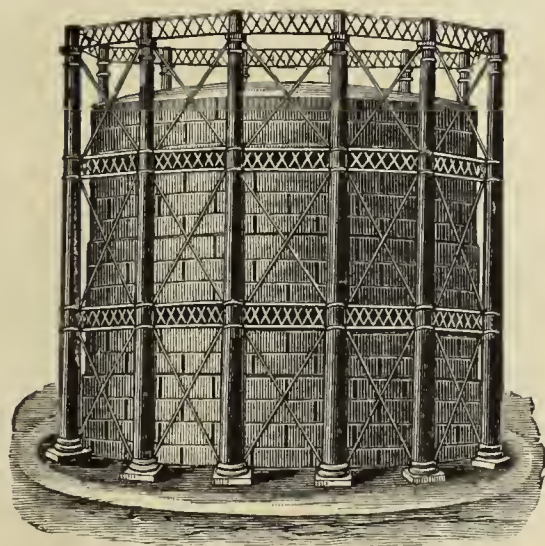

Iron Roofs.

Street Stops,

Valves, etc.

Stand-Pipes.

Water & Oil

Tanks, all Sizes.

Single, Double, and Triple-Lift Gas Holders.

SELF-SEALING RETORT LIDS. STAMPED STEEL RETORT LIDS.

Locomotive Water Columns, Filters, etc. Boiler Tubes, Wrought Iron Pipe & Fittings

Plans, Specifications and Estimates for all kinds of Machinery furnished on application.

Foundries & Works,
MILLVILLE, FLORENCE,
and CAMDEN, N. J.

R. D. WOOD & CO.,

Engineers,
Iron Founders,
and
Machinists.

400 Chestnut St., PHILADELPHIA, PA.

MANUFACTURERS OF

CAST IRON PIPE,

Gas Holders,

SINGLE, DOUBLE, AND TRIPLE LIFTS, WITH
OR WITHOUT WROUGHT IRON
OR STEEL TANKS.

PURIFIERS, CONDENSERS.

Scrubbers.

BENCH WORK.

Iron Floors and Roofs, Plate Girders.

Heavy Loam Castings.

HYDRAULIC WORK.

Lamp Posts, Valves, Etc.

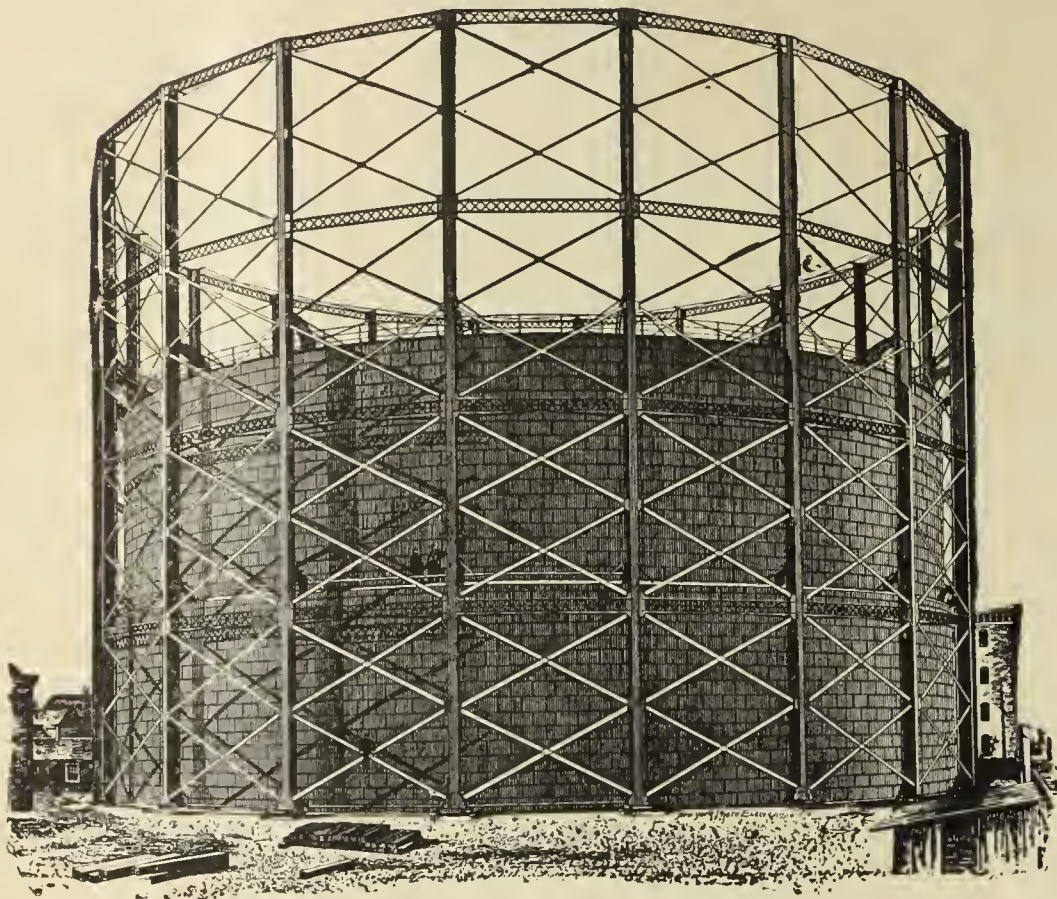

SMITH & SAYRE MFG. COMPANY,

G. G. PORTER, Prest.

245 Broadway, N. Y.

CHAS. W. ISBELL, Sec'y.

Machinery & Apparatus for Gas Works

Drawings, Plans, and Estimates Furnished for the Improvement, Extension, or Alteration of Gas Works, or for the Construction of New Works.

Mackenzie's Patent Rotary and Steam Jet Gas Exhausters, Governors, Compensators, Condensers, Washers, Scrubbers. Isbell's Patent Automatic Street Pressure Governor, Gas and Water Valves, Hydraulic Main Dip Regulator, Bench Castings, etc. Purifying Boxes and "Standard" Scrubbers, Isbell's Patent Self-Sealing Retort Doors.

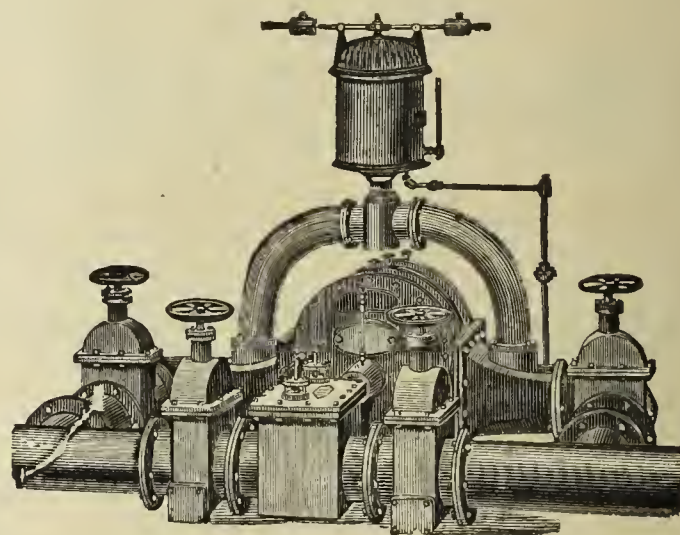

THE BRENNER SELF-SEALING RETORT DOOR.

Simple, Strong, and Durable.

CLOSES ABSOLUTELY TIGHT & IS LOCKED BY A CAM LEVER. ALL NECESSARY ADJUSTMENT FOR WEAR PROVIDED.

BUILT BY

SMITH & SAYRE MFG. CO.,

No. 245 Broadway, - - - New York City.

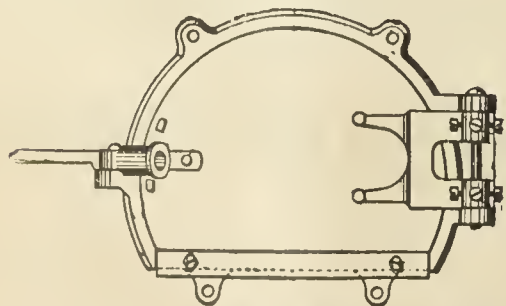

Brenner Self-Sealing Retort Door.

WILLIAM B. LUNDIE, Superintendent of the 42d Street Station of the Consolidated Gas Company, of New York, writes, under date of Jan. 4, 1889:

"We have 320 Brenner Self-Sealing Lids in use at this Station, built by the Smith & Sayre Mfg. Co. They require very little attention, and are the best of the kind that I have seen, giving entire satisfaction."

GAS WORKS APPARATUS AND CONSTRUCTION.

GAS WORKS APPARATUS AND CONSTRUCTION.

JAMES R. FLOYD & SONS,

(SUCCESSORS TO HERRING & FLOYD)

Oregon Iron Works,

W. 20th & 21st. Sts., bet. 10th & 11th Avs.,

NEW YORK CITY.

Engineers and Contractors

FOR THE

CONSTRUCTION OF GAS WORKS.

MANUFACTURERS OF

All Kinds of Castings and General Ironwork

FOR

GAS APPARATUS.

Bench Castings, Regenerative and Half Regenerative Furnace Castings.

Condensers, Scrubbers, Purifiers, Street Drips and Connections,

Valves,

Hydraulic Hoisting Purifier Carriage, Self-Sealing Retort Lids, Improved Valve Stand and Indicator,

Seller's Cement.

Plans, Specifications, and Estimates furnished for Construction of New or Alteration of Old Works.

CONTINENTAL IRON WORKS.

THOS. F. ROWLAND, Prest.

WARREN E. HILL and CHAS. H. CORBETT, V-Prests.

THOS. F. ROWLAND, JR., Sec. & Tr

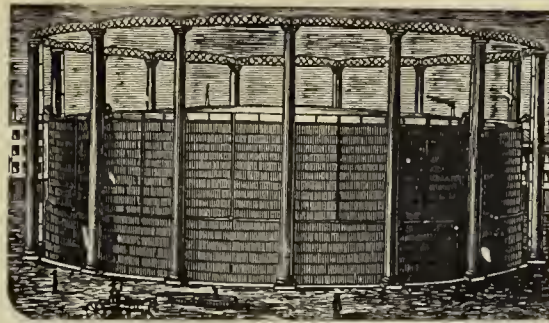

P. O. Station G., BROOKLYN, N. Y.

ENGINEERS AND MANUFACTURERS OF

Gas Holders

CONDENSERS, SCRUBBERS, VALVES,

PURIFIERS, SELF-SEALING RETORT LIDS

Hydraulic Mains,

And all other articles connected with the manufacture and distribution of Gas.

H. RANSHAW, Prest. & Mangr.

WM. STACEY, Vice-Prest.

T. H. BIRCH, Asst. Mangr.

R. J. TARVIN, Sec. & Treas.

STACEY MFG. CO.,

MANUFACTURERS OF

Single and Telescopic Gasholders,

IRON ROOFS, BRIDGES, LAMP POSTS,

Water and Oil Tanks, Coal Elevator Cars,

COKE CRUSHERS, BENCH CASTINGS,

And all kinds of Wrought and Cast Iron Work used in the erection of Coal and Oil Gas Works Rolling Mill Machinery and Heavy Castings a Specialty.

Foundry:

33, 35, 37 & 39 Mill Street.

Wrought Iron Works:

16, 18, 20, 22, 24 & 26 Ramsey Street:

Cincinnati, Ohio.

Bouton Foundry Co.,

FOUNDERS AND MACHINISTS,

CHICAGO, ILL.

Gas Works Apparatus,

PURIFIERS, CONDENSERS,

Bench Work

SPECIALS, LAMP POSTS,

SCRUBBERS,

Iron Roofs and Floors.

Plans and Estimates furnished for new works or extensions of old works.

1842. **DEILY & FOWLER,** 1890.

Laurel Iron Works.

Address, No. 39 Laurel Street, Philadelphia, Pa.

BUILDERS OF

GASHOLDERS,

Single and Telescopic.

Holdings Built 1884 to 1888, Inclusive:

- | | | | | |
|----------------------------|-----------------------------|---------------------------|--------------------------|------------------------|
| Newport, R. I. | Long Island City, N. Y. | Port Chester, N. Y. | Malden, Mass. | West Chester, Pa. (2d) |
| Portland, Oregon. | Macon, Ga. | New Rochelle, N. Y. | Paducah, Ky. | Lancaster, Pa. (3d) |
| Allegheny, Pa. (2d.) | York, Pa. | Salem, N. J. (3d) | Norwich, Conn. | Tacony, Pa. (two) |
| Atlanta, Ga. (2d.) | Chester, Pa. | Omaha, Neb. (2d) | Seattle, W. T. | Mount Vernon, N. Y. |
| N.Y. City (Central Gas Co) | Hazleton, Pa. (2d.) | Lynn, Mass. (2d) | San Diego, Cal. | Binghamton, N. Y. |
| Lynchburg, Va. (2d.) | Staten Island, N. Y. | Little Rock, Ark. | Northern Gas Lt. Co., of | Concord, N. H. |
| Saylesville, R. I. | Saugerties, N. Y. | Irvington, N. Y. | New York, N. Y. | Dover, Del. (2d) |
| Rondout, N. Y. | Clinton, Mass. (Lan. Mills) | South Boston, Mass. | Westerly, R. I. | Calais, Me. |
| Atlantic City, N. J. | Chattanooga, Tenn. | Rye, N. Y. (2) | Willimantic, Conn | New London, Conn. (2d) |
| Augusta, Ga. | Galveston, Texas. (3d.) | Woodstock, Ont. | Montclair, N. J. | West Chester, N. Y. |
| Waltham, Mass. (2) | Omaha, Neb. | Malden, Mass. | Attleboro, Mass. | Bay Shore, L. I. |
| Mahanoy City, Pa. | Fort Plain, N. Y. | Staten Island, N. Y. (2d) | Santa Cruz, Cal. | Washington, D. C. |
| New Castle, Pa. | Brunswick, Ga. | Woodstock, Ont. | Erie, Pa. (2d) | |

WM. HENRY WHITE,

No. 32 Pine Street, - - - New York City.

ENGINEER AND CONTRACTOR FOR THE

ERECTION AND EXTENSION OF

GAS, WATER, AND ELECTRIC LIGHT WORKS.

Correspondence with Gas Companies contemplating extending or improving their Plants respectfully invited. Plans and Estimates Furnished.

GAS COALS.

CANNEL COALS.

GAS ENRICHERS.

JAMES D. PERKINS. **PERKINS & CO.,** F. SEAVERNES.
228 & 229 Produce Exchange, New York.

Cable Address, "PERKINS, NEW YORK"

Post Office Box 3695, New York.

GENERAL SALES AGENTS FOR

The Youghioghenny River Coal Company's

OCEAN MINE YOUGHIOGHENY GAS COAL.

HON. W. L. SCOTT, Prest.

M. H. TAYLOR, Vice-Prest.

This Colliery is located at SCOTT HAVEN, PA., in the center of the Youghioghenny Gas Coal District, and produces the ONLY RELIABLE YOUGHIOGHENY COAL for gas purposes. (See Map on p. 87 of this JOURNAL, Feb. 16, '85.)

POINTS OF SHIPMENT,

Locust Point, BALTIMORE.

Pier No. 62, PHILADELPHIA.

Also, SOLE AGENTS for the

**BRECKENRIDGE CANNEL,
OF KENTUCKY.**

Within the past two years we have delivered this Cannel to over ONE HUNDRED COMPANIES IN THIRTY-THREE DIFFERENT STATES, and it is now in use in some of the large Gas Works

On the Continent and in South America,

where it successfully competes with the Australian Shale. It is the ONLY AMERICAN GAS CANNEL of sufficiently high grade to warrant EXPORTATION TO EUROPE AND SOUTH AMERICA, and it is the only economical substitute for OIL OR NAPHTHA. ONE GROSS TON will produce

10,000 Cubic Feet of 75 Candle Gas,	} equal to {	750,000 Candle Feet of Gas, and 26 Bushels of merchantable Coke weighing 900 Pounds
or 12,500 " " 60 " "		
or 15,000 " " 50 " "		

This is the ONLY GAS CANNEL that will produce a REALLY MERCHANTABLE COKE. It can be delivered in parcels of one carload or more to any point in the United States or Canada. Cargo shipments of any size required can be made from NEW YORK, PHILADELPHIA, BALTIMORE, or NEWPORT NEWS. Samples will be sent and particulars of price, etc., forwarded upon application to above address.

JAMES & WILLIAM WOOD,
Gas and Cannel Coal Contractors,

No. 40 St. Enoch Sq., Glasgow. No. 2 Talbot Court, London.

Proprietors of the BATHVILLE COLLIERIES (which produce the celebrated BOGHEAD CANNEL), Shields, Shieldmuir, Drumpeller, and other Collieries. This Firm offer

STANDARD CANNELS,

Unequaled as Gas Enrichers.

Analyses, prices, and all further information furnished on application to

Agency for U. S., Room 70, Nos. 2 & 4 Stone St., N.Y. City.

The Standard Oil Company,

REFINERS OF

NAPHTHA AND GASOLINES.

ALSO MANUFACTURERS OF

A Special Grade of Naptha for Gas Companies

FOR ENRICHING COAL GAS.

Correspondence solicited.

No. 43 Euclid Avenue, Cleveland, Ohio.

To Gas Companies.

We make to order CAP BURNERS to burn any amount under a stated pressure. Send for samples.

Also, SERVICE CLEANERS, DRIP PUMPS, and STREET MAIN PROVING APPARATUS.

C. A. GEFROER,

248 N 8th Street, Phila., Pa.

COKE CRUSHERS.

GAS COALS.

GAS COALS.

Newburgh Orrel Coal and Coke Co.

MINERS AND SHIPPERS OF

STEAM, SMITHING, AND GAS COALS,
Foundry and Crushed Coke.

Home Office, 33 S. Gay Street, Baltimore, Md.

J. HARRY LEE, President.

Shipping Wharves, Locust Point, Baltimore.

The Despard Gas Coal Co.,

MINERS AND SHIPPERS OF

DESPARD GAS COAL,

AND MANUFACTURERS OF

COKE.

MINES, Clarksburg, Harrison Co., W. Va.

WHARVES, Locust Point, Baltimore, Md.

OFFICE, 225 E. German St., " "

ROUSSEL & HICKS, } AGENTS. } BANGS & HORTON,
71 Broadway, N. Y. } 60 Congress St., Boston.

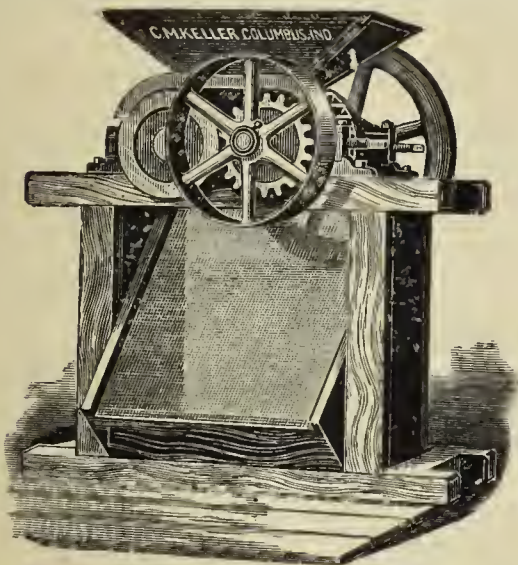

Keller's Adjustable Coke Crusher.

SIMPLE, STRONG, AND DURABLE.

C. M. Keller, Sec. & Supt. Gas Lt. & Coke Co. Columbus, Ind.

Correspondence Solicited.

King's Treatise on Coal Gas.

The most complete work on Coal Gas ever published.

Three Vols. Bound, \$30.

BOOKS.

DISTILLATION OF COAL TAR AND
AMMONIACAL LIQUOR.

By GEORGE LUNGE. Price \$12.50.

A TREATISE ON THE COMPARATIVE
COMMERCIAL VALUES OF GAS
COALS AND CANNELS.

By DAVID A. GRAHAM. 8vo., Cloth. Price \$3.

Orders for these books may be sent to this office.

A. M. CALLENDER & CO.,

42 PINE ST., N. Y. CITY

THE
PENN GAS COAL CO.

OFFER THEIR

Coal, Carefully Screened & Prepared for Gas Purposes.

Their Property is located in the Youghiogeny Coal Basin, near Irwin and Penn Stations on the Pennsylvania Railroad, and on the Youghiogeny River.

Principal Office:

209 SOUTH THIRD STREET, PHILA., PA.

Points of Shipment:

Pennsylvania Railroad Piers; Greenwich Wharves, Delaware River; Pier No. 1 (Lower Side), South Amboy, N. J.

Chesapeake & Ohio Railway Coal Agency,

FOR THE SALE OF THE

Superior Kanawha Gas Coals, Cannelton Cannel,
Also, SPLINT AND STEAM COALS.

From the Kanawha and New River Regions, on the line of the Chesapeake & Ohio R'way.

C. B. ORCUTT, General Agent, - - No. 1 Broadway (Room 217) New York City.

FRANCIS H. JACKSON, Prest.

EDMUND H. MCCULLOUGH, V.-Prest.

CHAS. F. GODSHALL, Treas.

H. C. ADAMS, Sec.

THE WESTMORELAND COAL CO.

Chartered 1854.

Mines situated on the Pennsylvania and the Baltimore
and Ohio Railroads, in Westmoreland County, Penn.

POINTS OF SHIPMENT:

PHILADELPHIA, BALTIMORE, SOUTH AMBOY, N. J.,
WATKINS (SENECA LAKE), N. Y.

Since the commencement of operations by this Company its well-known Coal has been largely used by the Gas Companies of New England and the Middle States, and its character is established as having no superior in gas-giving qualities, and in freedom from sulphur and other impurities.

Principal Office, 224 South 3d St., Phila., Pa.

The American Gas Engineer
and Superintendent's Handbook.

By WILLIAM MOONEY.

Consisting of Rules, Reference Tables, and Original Matter
Pertaining to the Manufacture, Manipulation, and
Distribution of Illuminating Gas.

350 Pages, Full Gilt Morocco.

\$3.00.

A. M. CALLENDER & CO., 42 Pine St., N. Y.

JOHN J. GRIFFIN & CO.,

Nos. 1513, 1515, 1517 & 1519 Race Street, PHILADELPHIA.

52 Dey St., NEW YORK.

75 N. Clinton St., (FRED. R. PERSONS, Mangr.) CHICAGO.

MANUFACTURERS OF

METERS FOR MEASURING GAS

IN ANY VOLUME.

Provers, Gauges, Registers, Etc., Etc.

EXPERIMENTAL APPARATUS FOR QUANTITATIVE AND QUALITATIVE ANALYSIS.

Careful and Prompt Attention paid to Repairing of all kinds of Meters and Apparatus.

Estimates Cheerfully Furnished.

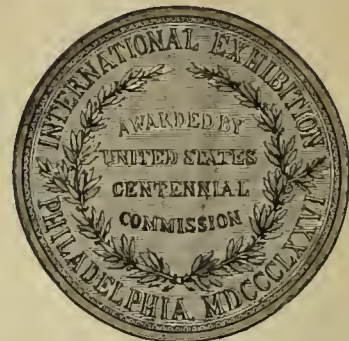

NATHANIEL TUFTS,

No. 153 Franklin Street, Boston, Mass.,

MANUFACTURER OF

DRY GAS METERS.

Station Meters of any Capacity.

Test and Experimental Meters, Pressure Registers, Pressure Gauges, Pressure and Vacuum Gauges.

METER PROVERS, PHOTOMETERS, STREET LANTERNS, ETC., ETC.

Patent Cluster Lanterns for Street Illumination.

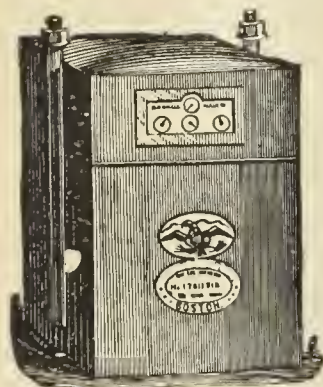

Dry Gas Meters.

With 40 years' experience and the best facilities for manufacturing, is enabled to furnish reliable work and answer orders promptly.

HAROLD J. BELL.

BELL & JONES,

S. LEWIS JONES.

No. 12 North Ninth Street, Philadelphia, Pa.

Works at Royersford, Pa.

MANUFACTURERS OF

GAS METERS, STATION AND EXPERIMENTAL METERS,

Meter Provers, Pressure Gauges, and All Other Gas Appliances in Our Line.

WE REPAIR ALL KINDS AND MAKES OF METERS, AND THE WORK GUARANTEED.

High Pressure Meters for Natural Gas, in Iron Cases, guaranteed to stand 300 lbs. Pressure.

Gas Cooking and Heating Stoves, Hot Plates, Cake Griddles, Waffle Bakers, Boiling Stoves, Laundry and Tailors' Iron Heaters. Hotel and Cafe Ranges a Specialty.

Correspondence Solicited.

Estimates Furnished.

A. HARRIS.

E. L. HARRIS.

J. A. HARRIS.

Established 1849.

HARRIS BROS. & CO.,

Twelfth and Brown Streets, Philadelphia.

Manufacturers of Wet and Dry Gas Meters,

STATION METERS, METER PROVERS,

EXPERIMENTAL METERS, SHOW OR GLAZED METERS,

Pressure and Vacuum Registers, Gauges, Photometers, Drip and Bell Pumps, Etc., Etc.

PROMPT ATTENTION GIVEN TO ALL ORDERS. METERS THOROUGHLY REPAIRED. ESTIMATES FURNISHED FOR STATION METERS OF ALL SIZES. CORRESPONDENCE SOLICITED.

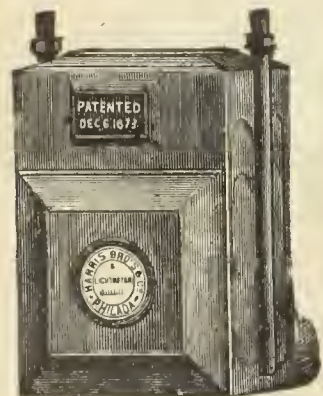

GAS METERS.

GAS METERS.

GAS METERS.

GEO. J. MCGOURKEY, Prest.

WM. H. MCFADDEN, Vice-Prest. (Phila.)

WM. N. MILSTED, Gen. Supt. and Treas. (New York).

WM. H. DOWN, Sec.

THE AMERICAN METER CO.

Established 1834.

Incorporated 1863.

WET AND DRY GAS METERS.

PRESSURE REGISTERS.

METER PROVERS.

STATION METERS.

PRESSURE & VACUUM REGISTERS.

PORTABLE TEST METERS.

EXHAUSTER GOVERNORS.

PRESSURE & VACUUM GAUGES.

EXPERIMENTAL METERS.

DRY CENTER VALVES.

CRESSON GAS REGULATORS.

AMMONIA TEST METERS.

GOVERNORS FOR GAS WORKS.

MARSLAND WATER METERS.

BAR & JET PHOTOMETERS.

Manufactories:

512 West 22d St., N. Y.
Arch & 22d Sts., Phila.

GAS STOVES.

SUGG'S "STANDARD" ARGAND BURNERS,
SUGG'S ILLUMINATING POWER METER,
Wet Meters, with Lizar's "Invariable Measuring" Drum.

Agencies:

177 Elm Street, Cincinnati.
244 & 246 N. Wells Street, Chicago.
810 North Second Street, St. Louis.
222 Sutter Street, San Francisco.

HELME & McILHENNY,

(Established 1848.)

CAS METER MANUFACTURERS,

Nos. 1339 to 1349 Cherry Street, Philadelphia, Pa.,

WET AND DRY GAS METERS. STATION METERS, EXPERIMENTAL METERS, METER PROVERS,

Center Seals, Pressure Registers, Governors, Indicators, Photometers, and all other kinds of Apparatus for use in Gas Works.

FOULIS' PATENT STATION AND DISTRICT GOVERNORS.

REPAIRING DEPARTMENT.—We employ a special force of skilled workmen repairing meters of all makers.

WM. WALLACE GOODWIN, President and Treasurer.

E. STEIN, Vice-President.

H. B. GOODWIN, Secretary and Superintendent.

THE GOODWIN GAS STOVE AND METER CO.,

Successors to W. W. GOODWIN & CO.

1012, 1014 and 1016 Filbert St., Phila., Pa.

113 Chambers St., New York City.

76 Dearborn, St., Chicago, Ills

WALDO BROTHERS, Agents, 88 Water Streets, Boston, Mass.

MANUFACTURERS OF

DRY AND WET GAS METERS,

Station Meters (square, cylindrical, or in staves), Glazed Meters, King's and Sugg's Experimental Meters, Lamp Post Meters, etc., etc. Meter

Provers (sizes 2, 5, and 10 feet), Pressure Gauges of all kinds, Pressure Registers, Pressure and Vacuum Registers, Pressure Indicators

(sizes 4, 6, and 9 inch), King's Pressure and Vacuum Gauges, Dry and Wet Center Seals, Dry and Wet Governors, Exhauster

Governors, Photometers of all descriptions. Letheby's Sulphur and Ammonia Test Apparatus complete. Also, Testing

and Chemical Apparatus of all kinds, and of the most perfect description, for all purposes relating to Gas.

Manufacturers of the "SUN DIAL" GAS STOVES, for Cooking and Heating.

Goodwin's Improved Lowe's Jet Photometer.

Agents for Bray's Patent Gas Burners and Lanterns.

Special attention to Repairs of Meters and all Apparatus connected with the business. All work guaranteed first-class in every particular. Orders filled promptly.

G. B. EDWARDS, Manager, New York.

S. S. STRATTON, Manager, Chicago.

D. McDONALD & CO.,

GAS METER MANUFACTURERS.

(Established 1854.)

51 Lancaster St., Albany, N. Y.

34 & 36 West Monroe St., Chicago, Ill.

STATION METERS, EXPERIMENTAL METERS, METER PROVERS, PRESSURE & VACUUM REGISTERS, PRESSURE GAUGES, ETC.

Also STAR GAS STOVES, RANGES, and HEATING STOVES.

We use only the very best materials, and employ the most skilled labor, and by our long experience (36 years) and personal supervision of every detail, we feel justified in assuring the public that our goods will give perfect satisfaction. Every Meter emanating from our establishment will bear the State Inspector's BADGE, and will be fully warranted by us. Our Annual and Calendar will be sent to Gas Companies upon application.

WM. WALLACE GOODWIN, President. E. STEIN, Vice-President. H. B. GOODWIN, Sec. & Supt. G. B. EDWARDS, Mang'r, New York. S. S. STRATTON, Mang'r, Chicago.

THE GOODWIN GAS STOVE AND METER CO.,

1012-18 Filbert St., Phila., 113 Chambers St., N. Y., 76 Dearborn St., Chicago.

Agents, WALDO BROTHERS, 88 Water Street, Boston.

SOLE MANUFACTURERS OF THE

“SUN DIAL” GAS STOVES,

The Most Economical, Efficient, and Durable Gas Stove Made.

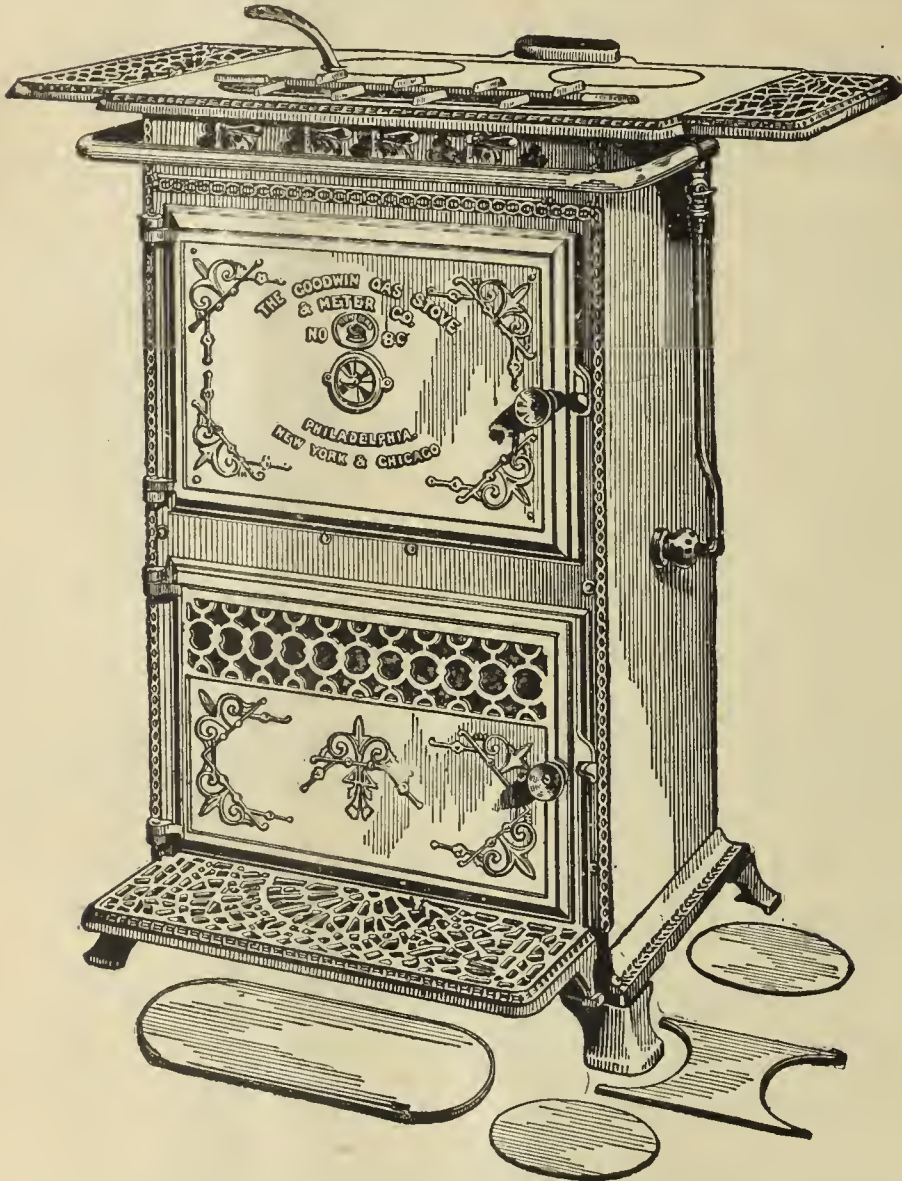

GAS COOKING STOVE, No. 8 C.

SIZE.

Stove.	Oven.	Roaster.	Top.	Length over Extension Shelves,
37 in. high.	12 in. high.	12 in. high.	24 in. long.	36 in.
20 in. wide.	17½ in. wide.	18 in. wide.	21 in. wide.	
	12 in. deep.	13 in. deep.		

This Stove has four burners on top, and double oven burner. Consumption of gas with all burners in use, 42 feet per hour, at 1 inch pressure. The top is made in sections, so that a greater variety of cooking utensils may be used. By lifting out the covers and crosspieces and putting in a suitable forked ring, which is sent with each stove, a wash boiler or other large utensil may be set over two burners. Our **No. 87 GRIDDLE** also fits in the same position. The roasting oven is provided with a cast-iron door.

All Fittings are Nickel-Plated.

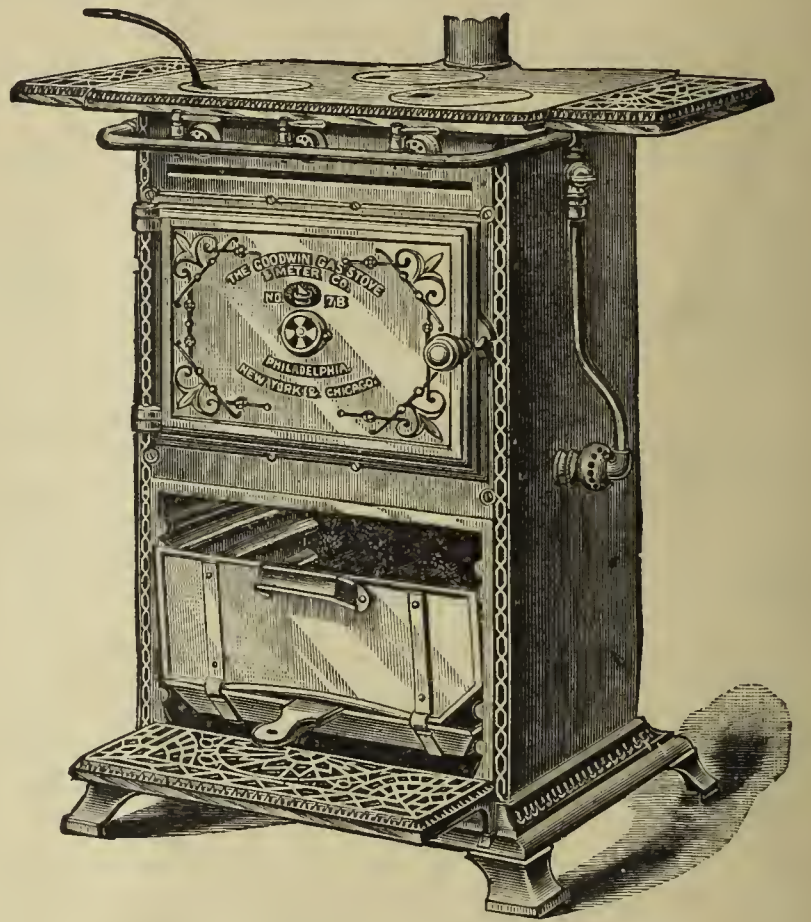

GAS COOKING STOVE, No. 7 B.

SIZE.

Stove.	Oven.	Roaster.	Top.	Length over Extension Shelves,
31 in. high.	9½ in. high.	10 in. high.	21 in. long.	32 in.
17 in. wide.	14½ in. wide.	15 in. wide.	16 in. wide.	
	12 in. deep.	13 in. deep.		

This Stove has three boiling burners in the Top or Hot Plate, and one single oven burner.

This cut represents our New Style Cooking Stove. As will be seen, it has an ornamented cast-iron Base and Front, and extension shelves. The Oven Burner, which is atmospheric (unless otherwise ordered), is of an entirely new and improved pattern (patent). The ovens are of greater capacity than those of the old style. The Top, in conjunction with the Outlet Pipe, is designed to carry off all the products of combustion, if desired, but they are also supplied with a loose ring which converts it into an ordinary open top stove.

The consumption of this Stove is 35 cubic feet per hour at 1 inch pressure, with all Burners in use.

All Fittings are Nickel-Plated.

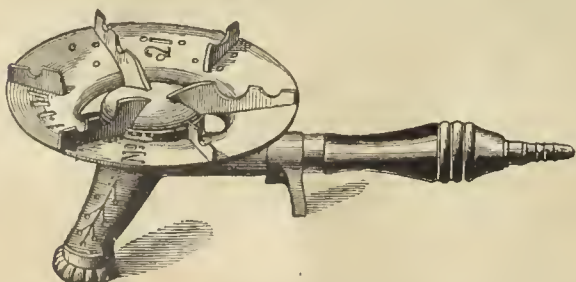

“RADIANT” BOILING STOVE, WITH REGENERATIVE BURNER.

Size, 6½ inches diameter, 8 inches high. Consumption, 6 feet per hour at 1 in. pressure.

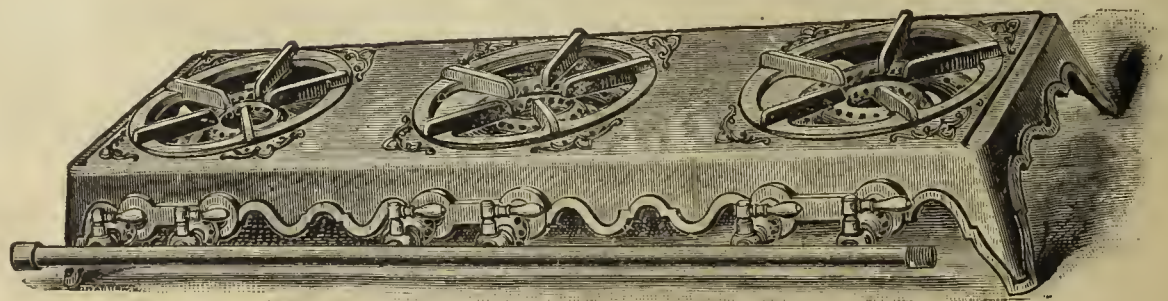

HOT PLATE, No. 111.

Size, 36 in. long, 12 in. wide, with three double burners, 6 taps. Consumption, with all burners in use, 36 cubic feet per hour, with 1 in. pressure. ½ in. supply pipe should be used where the pressure is 1 in. or over.

THE AMERICAN

GAS LIGHT JOURNAL

REDMAN & KENNY, N. Y.

PUBLISHING OFFICE No. 42 PINE STREET

DEVOTED TO THE INTERESTS OF ILLUMINATION, VENTILATION, WATER SUPPLY AND DISTRIBUTION, & GENERAL SCIENCE.

VOLUME LII.—No. 26.
Whole No. 786.

NEW YORK, MONDAY, JUNE 30, 1890.

{ \$3 PER ANNUM,
IN ADVANCE.

A. M. CALLENDER & CO., Proprietors. C. E. SANDERSON, Manager.
JOS. R. THOMAS, C.E., Editor. T. J. CUNNINGHAM, Asst. Editor.

ENTERED AT THE POST OFFICE AT NEW YORK, N. Y.
AS SECOND CLASS MATTER.

Published on each Monday of the year, at No. 42 Pine Street, N. Y.

Terms of Subscription, Including Postage.—For the United States and Canada, \$3 per annum. European countries, \$4.50 (19 shillings—22½ francs). All payments to be made in advance. Single copies, 10 cents.

Remittances should be made either by post-office order, express money order, registered letter, or bank draft on New York, payable to the order of A. M. Callender & Co.

CONTENTS.

An Asterisk (*) denotes an illustrated article.

EDITORIALS—

Obituary—James Henri Rollins.....	909
Briefly Told.....	910
Mr. Stedman Tells the Whole Truth—The Messrs. Wilbraham Bros. Purchase the Huntoon Patents.	
The Market for Gas Securities.....	910
Thirteenth Annual Meeting, Western Gas Association—Official Report, Revised by the Secretary—Concluded from Page 881.....	910
Mixed Gases, by Mr. E. G. Cowdery—The Effect of Natural Gas Competition, by Mr. Jas. Somerville—Joint Discussion—A Batch of Invitations—Wrought Iron, Cast Iron or Steel: which is the Best Material for Street Mains? by Mr. Eugene Printz—Discussion—Appointing Committee of Arrangements and Committee to Name Place for Meeting, 1892—Votes of Thanks—Report of Committee on Resolutions.	
Modern Measurements.....	917
Special English Correspondence.....	917
The Gas Institute—The Labor Question—Sulphur Recovery—Improvements in Gas Apparatus.	
Assay of Coal.....	918
ITEMS OF INTEREST FROM VARIOUS LOCALITIES.....	919

Charter Renewed, Hempstead, L. I.—Mr. Hayden Goes to Schenectady, N. Y.—Business of the Roots Company—Cheaper Gas for Providence, R. I.—Dis-solving the American Gas Improvement Company—A Fuel Gas Company for Asheville, N. C.—Winding up the Troy (N. Y.) Electric Light Company—Bet-terments at Evansville, Ind.—Iron Stock House for Isabella Furnace—Cheaper Gas for Rock Island, Ills.—Improvements at Charlestown, Mass.—Better-ments at Las Vegas, N. M.—Sale of the Bay Shore (L. I.) Works—Married—Opposition at Quincy, Ills.—And Many Other Items.

OBITUARY—JAMES HENRI ROLLINS.

It is with much sorrow that we announce to the fraternity the death, on the evening of June 19, at his home in Oread Place, Worcester, Mass., of Mr. James H. Rollins, whose name and fame had earned for him a prominent place in the ranks of Eastern gas engineers. Of course, we can but sorrow over the gap thus caused in the ranks, still to de-ceased there can be no question that the ending was release from severe bodily affliction, borne with fortitude and heroism for three long years. The disease from which he suffered was neuritis, or inflammation of the nerves, which is about as acutely painful a malady as the human frame can be called upon to bear. James Henri Rollins was born at Melvin, N. H., in the spring of 1836, and having acquired a common school ed-ucation, was early attracted to the possibilities involved in the develop-ment of the gas business. The first safe record that we have of his con-nection with the business is his service with the Boston Gas Light Com-pany. Apt and bright, he mastered the details of the craft with such speed that, the opportunity offering, he accepted a contract to build a

works at Cairo, Ills. This task completed he returned East to accept a position with the Brookline, Mass., Company, where he remained until October, 1870. At that time an inviting field opened up to him in the shape of the position of Manager and Superintendent of the Minneapolis, Minn., Company, in the service of which he remained 5 years, acquit-ting himself with signal ability, as the records of that Company amply prove.

In 1875 a call for duty summoned him once more to the East, and in the fall of that year we find him in harness as successor to Mr. F. C. Sherman (who resigned from Worcester in order that he might take ser-vice at New Haven, Conn.) as Agent for the Worcester (Mass.) Gas Com-pany. His faithful and valuable labors at this point are too well known to the fraternity to call for extended comment. Suffice it, then, to say that they were of a nature which gave credit to himself, profit to his em-ployers, and satisfaction to the Company's patrons. Failing health alone compelled him (in the spring of 1887) to resign from active duty, and since his retirement, as noted at the beginning of these lines, his failing days have been those of acute bodily pain. His strong mentality, how-ever, remained to the end, and his anguish was, in consequence, all the more pronounced. Ever active in promoting the best interests of his profession, it is therefore not to be wondered at that his name appears on the rolls of several of our Associations, and that it was so written in the early days when many doubted whether or not the policy of meeting in open communion was a safe means for the advancement of gas engi-neering. Whether or not Rollins was a doubter in this regard is best answered by noting that his name appears on the roster of the Ameri-can Association at the meeting held in October, 1873, although we be-lieve the first meeting he attended was that held in New York, in 1875. He was an ardent supporter of the Association, and although the only office held by him in it was as member of the Executive Committee ('82-'83), he often assisted in guiding it smoothly in trenchant debate. He was elected to membership in the New England Association at the meet-ing held at Boston, in 1876, and served on its Board of Directors during 1879, '80, '81 and '82. Here his counsel was often sought, nor was he ever appealed to in vain. He was one of the founders of the Guild of Gas Managers, who perhaps will miss him most, since it was at their gatherings that his genial nature was shown at its best. Of all these or-ganizations he was a member at the time of his death, and it seems su-perfluous to add that all will miss him sadly.

He was a man of great strength of character and mind, an engineer of marked ability—both executive and technical—whose methods and re-sults were always abreast the times. As a manager he caused every-thing to be secondary to and for the advancement of the interests of his employers. Honest and trustworthy as an employee, he was equally rated to acquire and retain the esteem and unrestrained affection of his friends. True as steel, his steadfastness to his friends was a type of that manhood which safely passes through the crucible of time; each successive year but proving the fine grain of his af-fection. In Masonic orders he attained high rank, and claimed kin-ship with the Quinsigamond Lodge of Masons, Eureka Royal Arch Chapter, Hiram Council and Worcester County Commandery of Knights Templars. The burial services took place at his late residence, on Mon-day, June 23, the Reverend Dr. Means, of Piedmont Church (of which

Mr. Rollins had long been a faithful member) officiating. A large assemblage was present, and amongst those who assisted in the last sad rites were Messrs. Bill, Learned, Prichard, Coffin, Leach, Andrew, Taber, Quinn, Slater, Rogers, Humphreys, Spaulding, Coburn, Tarbell, Waldo, Langford, Sherman, Spear, Wetherbee, Cogshall, Davis and Lamson—a list that resembles very much the roll-call of the Guild of Gas Managers or that of the New England Association.

Grief we must feel at the death of the gifted and genial Rollins; but may we not temper it in the remembrance of the cessation of his suffering and in the brighter glory that surrounds the memory of those who having worked faithfully and well in life leave to us the records of that life work as mute guides to us in our approach to the revealment of the life that is beyond.

BRIEFLY TOLD.

MR. STEDMAN TELLS THE WHOLE TRUTH.—Not that he does not always do so, but memory cannot always be trusted, when time presses, to report everything and at once. Early last week Col. Stedman paid a brief visit to the JOURNAL office, and in conversation said he expected to pass the summer (or a part of it) in Alaska, whereupon the interviewer got in his fine work, a condensed report of which is to be found in our item columns. Since then, however, we have received a somewhat amendatory letter of explanation as to matters connected with the Colonel's proposed summering in Alaska, and it is so characteristic of him that rather than mangle his words we reprint them verbatim. The letter is under date of the 25th inst., and is as follows:

To the Editor AMERICAN GAS LIGHT JOURNAL: "It occurs to me that in our interview on Monday I failed to give you a complete statement of my purpose in making my journey to Alaska, and that in putting you off with a remark about the glaciers and icebergs I was needlessly leading you into an error which might not accord with the usual reliability of editorial statement in the JOURNAL. Now I will tell you the whole truth about it. I am acting in the interest of a Rochester syndicate whose purpose is to obtain, if possible, a controlling interest in the Northern Lights and to transfer them to Rochester for its exclusive use in lighting the streets. Of course, we don't expect to confine their radiance within our own civic boundaries. Enough light will probably be reflected from the sky to tantalize the citizens of Buffalo and surrounding cities, and gradually lure them to become residents of a place so blessed as Rochester with its natural and to be acquired advantages; for allow me to introduce Secretary McClintock, of the Rochester Chamber of Commerce. This gentleman is in hearty accord with every measure intended to benefit this beautiful and enterprising city. He is intent on introducing natural gas here, and has already so excited the interests of the natives in the environs of Rochester that several new sources of supply have been very nearly discovered in the immediate vicinity. But the Secretary casts his eyes further afield, and in the event of a deficiency in wells which may be driven within a few miles of the city, the pipes will be laid to the big producing fields already developed and a bountiful delivery assured. The same gentleman has another scheme for so hoarding the surplus of the Genesee river as to compel that somewhat variable stream to be reliable and constant in its work the year round. An estimate, indorsed by the State Engineer, gives 30,000-horse power per day as the minimum which, under this storage plan, would turn the wheels of our industries every day in the year.

"With heat, power and light thus secured, Rochester will in the next decade enormously outrun its 80 per cent. increase in the last."

THE MESSRS. WILBRAHAM BROS., of Philadelphia, have purchased the patent of the late R. K. Huntoon, of Franklin, Mass., for his gas governor, together with all rights, patterns, stock, etc., and are prepared to fill orders for same.

The Market for Gas Securities.

There is no change of moment in the market for city gas shares. Summer dullness may now be said to have set in. Consolidated is around par, with but few transactions. Mutual is stronger. Brooklyn shares are steady. In our item columns will be found mention of the incorporation of a Company in Trenton, N. J., with a capital of \$50,200,000. This Company is the result of certain negotiations that have been in progress for some time whereby English capital becomes interested in the United Gas Improvement Company. The new corporation takes over the capital of the latter, paying therefor at the rate of 200. English and American capital in the venture are about equally balanced. The negotiations were conducted by Sir Henry Goldsmid on behalf of the foreign capital, and Messrs. A. C. Humphreys and Randal Morgan for the Americans.

[OFFICIAL REPORT—REVISED BY THE SECRETARY—CONCLUDED FROM PAGE 881.]

THIRTEENTH ANNUAL MEETING OF THE WESTERN GAS ASSOCIATION.

HELD AT ST. LOUIS, MO., MAY 21, 22 AND 23, 1890.

SECOND DAY—MAY 22—AFTERNOON SESSION.

Mr. E. G. Cowdery, of Milwaukee, Wis., read his paper on MIXED GASES.

Gentlemen of the Association:—It is but little more than two weeks since I accidentally discovered the announcement in the AMERICAN GAS LIGHT JOURNAL that I was booked to read a paper before this Association upon "Mixed Gases." It had been my intention to give you a paper upon an entirely different subject, and I had so expressed myself to the gentleman entrusted with the records of this body; how he ever got so badly "mixed" over a gaseous subject is beyond my power to explain. Having, then, one thing as a subject and another written, it remains for you to apply the subject as best you can.

My paper was intended to lay before you the result of some practical experiments with "gaseous fuel." The subject of fuel gas has been variously presented to you by different members for the past three years, but it has seemed to me, as it has to many others, that while all these efforts towards solving the question in a theoretical way have beyond question been very able, they have nevertheless lacked enough of the practical to convince many of their ultimate success. For this reason it seemed that the result of a few practical experiments would not come amiss.

To be able to judge how far practice would bear out theory I conceived the idea of trying an experiment to find the comparative heating value of different gases, as it would be accomplished in the ordinary practical way. To do this and make the experiment under conditions as favorable as practice would allow, I had made a pan, 9 inches in diameter and 5 inches deep, with tin sides and copper bottom; this to hold 10 pounds of water, and to be used over a gas stove having an equalized flame spreading over a diameter of 5 inches. With 10 pounds of water in the pan, a thermometer suspended so that the bulb was in the center of the body of water and the top of the dish covered with glass, the gas was lighted and as soon as the mercury reached 70° the statement of the meter was taken. When the mercury reached 210° the gas was shut off. If there had been 4 feet of gas used to raise this 10 pounds of water 140° the 4 feet would have raised 1 pound of water 1,400°, or 1 foot would have raised 1 pound 350°. We judge from this that we have obtained in practice 350 units of heat from 1 foot of the gas; the balance of the theoretical heat units in the gas was, of course, wasted.

Care was exercised in obtaining the proper length of time to raise this body of water 140° in temperature with the minimum waste of heat, which in this case was found to be about 20 minutes. The gas stove was so constructed as to allow of adjustment of air and gas separately. These were so adjusted for each gas tried as to produce the best result. The following results were obtained:

Ordinary coal gas, 16 to 17-candle power	311 units.
Uncarbureted water gas (no air)	157 units.
Carbureted water gas, 25 to 30-candle power	408 units.

It was found that the burner we were using for the uncarbureted water gas was not best adapted for it, and another was substituted, which is specially made and adapted for that gas.

The results for coal gas were also improved by using a different burner. With these improved burners the results from the same gas were:

Uncarbureted water gas (no air)	183 units.
Coal gas, 16 to 17 candle power	345 units.

It happened at this time to be convenient for me to test with the same apparatus in the same way a fuel gas said to be a combination of coal gas and uncarbureted water gas, and, of course, superior in heating qualities to uncarbureted water gas alone. The result was as follows:

With original burner	127 units.
With special burner	153 units.

Against uncarbureted water gas straight:

With original burner	157 units.
With special burner	183 units.

The so-called fuel gas in this case was 16 per cent. less in heating quality than the straight uncarbureted water gas.

With this result of a practical experiment with various gases, with the same apparatus and under precisely similar conditions, and so nearly

bearing out the theoretical comparison, what conclusions are we to draw? Simply that we must accept the comparative values placed below as facts, with the value of

Uncarbureted water gas placed at.....	100
Ordinary coal gas, 16 to 17 candle power, will be..	200
Carbureted water gas, 25 to 30 candle power.....	250
Mixed, $\frac{3}{4}$ coal, $\frac{1}{4}$ water gas	215

So far, where "fuel gas" has been practically applied, the products of combustion, either partially or altogether, have been thrown into the heated rooms. No doubt this was done to save heat; for if we are to attempt to reach a price equal to the cost of coal every available means must be taken to reduce the waste heat to the minimum. I do not hesitate to say that I believe any scheme which fails to dispose of all the products of combustion is doomed to absolute failure.

Believing this, I set about devising a way to heat the office building at the works in our city the past winter, and carried out a plan, which was perfect in its plan for heating, which disposed of all the products of combustion by throwing them into the chimney and which reduced the waste of heat to the minimum, as they never entered the chimney above 75°. It was a hot water circulating system, direct radiation, and I believe for either gas or for coal is the cheapest system of heating to operate. A boiler or heater composed of copper tubes was built for the purpose and so arranged that the gas flame played upon the upper portion of the coil, the products of combustion being drawn down through the heater around the tubes by the draft of the chimney, thus coming in contact with the coldest water before entering the chimney. As the temperature of the water entering the heater at the bottom was never above the temperature of the room, the products of combustion could not enter the chimney at a higher temperature. The room heated was 43 x 24 feet and 12 feet high, equaling 12,384 cubic feet of space. To get a comparison with coal I commenced burning anthracite coal at my house on the 1st of November last, the same day as these gas heaters were put into operation. As both buildings are solid brick and about equally exposed, and the rooms in each case 12 feet high, I consider the comparison very fair. The space heated with coal equaled 53 feet by 33 feet and 12 feet high, and equaled 20,988 cubic feet of space. From November 1st to March 15th we burned at the one place 57,500 feet of gas, at the other $9\frac{2}{3}\frac{5}{10}\frac{0}{10}$ tons of anthracite coal.

Again: At one place, 4,643 cubic feet gas to heat 1,000 cubic feet space; at the other, 917 pounds coal to heat 1,000 cubic feet space. It thus appears that 10,000 cubic feet of gas equaled, in this case, 1 ton of anthracite coal. As it took 4,643 cubic feet of gas to heat 1,000 cubic feet of space for 4½ months, and these the coldest months of the season, it certainly would not increase the proportion for the remaining 1½ months. Allowing the same proportion, it would cost \$4 per 1,000 cubic feet of space for a season of 6 months, from November 1st to May 1st, for gas at 65 cents per 1,000 feet, and same price for coal at \$6.50 per ton. As the gas we were making the past winter was three-fourths coal gas and one-fourth water gas, and had a comparative heating value of $2\frac{1}{10}\frac{5}{10}$ times uncarbureted water gas, its value would be placed at 35 cents, against uncarbureted water gas at 30.

As Mr. Evans is selling an uncarbureted water gas at 30 cents, and as he stated in his paper at the Ohio meeting, recently, that at that price for his gas, it cost about \$4 per 1,000 cubic feet of space heated, it appears to me that these figures are somewhere near reliable. I should have stated that the coal was used in a new and what appears to be a good hot air furnace.

I do not know that any of us care to, or can afford to sell our illuminating gas at 65 cents per 1,000 feet; but if we cannot, then we certainly cannot afford to sell uncarbureted water gas at 30 cents. If we can get 40 cents for an uncarbureted water gas—which we ought—and can, at that figure, make a profit, we can make a larger profit in selling illuminating gas at 80 to 90 cents for the same purpose.

It is no argument that a fuel gas plant making uncarbureted water gas would require less capital in the works; for this would be more than offset by the additional cost of mains to carry twice the amount of gas.

It is an inevitable fact that so far as we have progressed at present, a successful "fuel gas" must be some kind of an illuminating gas.

The President here intimated that the Association was pressed for time, and suggested that as the paper by Mr. Somerville was somewhat in the nature of the one read by Mr. Cowdery, that the Somerville paper be read so that a joint discussion might be held. This was agreed to, and Mr. James Somerville, of Indianapolis, Ind., read his paper on

THE EFFECT OF NATURAL GAS COMPETITION.

This paper, on the "Effect of Natural Gas Competition," can only interest those of our number who are enjoying the blessing of this most

wonderful of Nature's products. The Committee were kind enough to suggest the subject to me, and as I happen to be one of those unfortunate people who have a peculiar difficulty in saying "No," at the right time, I had just to comply with their suggestion.

It is a little over two years since natural gas was introduced into our city, giving it ample time to show its effects as a competitor with the manufactured article. The natural gas is found in great abundance at a point 20 miles distant, and is brought to the city by three lines of pipe. One line is part 16-inch and part 12-inch; the second line is all 12-inch; the third line is part 8-inch and part 10 inch. The pressure at the wells is 300 pounds to the square inch, and it is estimated that these three lines of pipe will deliver into the city forty million cubic feet per day. The illuminating power of the gas is 9.5 candles. Its specific gravity is .570. It is practically free from impurities. When first introduced it showed decided traces of sulphureted hydrogen, turning the test-paper black the moment it was applied. But about one year after its introduction, from some cause which I am unable to explain, it ceased to show the slightest trace of this impurity. There were four companies organized to supply the city, but only three of them went to work. So great was the desire of the people for the new and cheap fuel that they readily granted the freedom of the city to the companies, and the contractors took full advantage of that freedom. The way the streets were torn up, ditches left open for weeks, entire squares of the city cut off from traffic, was somewhat surprising to the regular gas man, who had been accustomed to conduct his main-laying with the fear of the municipal authorities before his eyes. It was the great desire of the companies to get into the creamy part of the city first. The better and least expensive plan would have been to have given each of the companies a district to itself, as the price of gas was fixed by ordinance. But as this was not done, we have often three main-pipes in one street, when one would have been sufficient.

I found it next to impossible to properly watch and protect our mains and services during these operations. A number of gangs would be working at once in different parts of the city, and if a service-pipe came in the way of their main, the handy crow-bar was brought into requisition with telling effect. The service-pipe would either be broken or pulled clean out of the main and covered up, to be revealed in the near future in the usual way. I must give the companies credit, however, for doing the best they could under the circumstances to protect our property, and when we presented the bill for repairing the damages they paid it without a murmur.

Before the natural gas was turned on the mains were all carefully tested. The high pressure mains, which encircle the city, had to stand an air pressure of 80 pounds to the square inch. The low pressure, 15 pounds to the square inch. The city engineer, to whom was intrusted the testing operations, performed his duty faithfully and well. The consequence is, we have had no accident whatever from leaking main-pipes. The gas is burned at a pressure of 7 oz., equal to a water column of 13 inches in height.

The great number of houses waiting to be fitted up for the use of the new fuel brought a host of gas-fitters from all parts of the Union, chiefly from the natural gas regions. Every person in the city who had ever handled a pair of pipe-tongs turned gas-fitter. It was not an unusual occurrence to see the shoemaker take down his sign which read "Boots and Shoes Neatly Repaired," and put up one with this legend on it, "Natural Gas Fitting Done on Short Notice." Of course it was impossible to control such a crowd or specify the size of pipe to be used, for they went into the lighting business also. But natural gas companies took in the situation, and promptly issued an order that no gas should be turned on unless the occupant of the house had a certificate, signed by their inspector, to the effect that the fittings had stood a pressure of 10 pounds to the square inch. The order was faithfully carried out, and I have known instances where the fitter would spend two days in fitting up the house and be occupied four and five days in stopping the leaks. The troublesome mercury would insist upon obeying the laws of gravitation.

When the work of fitting up 19,000 houses was completed the business began to slacken, and the question of earning an honest penny by our army of gas-fitters was an important one. They went from house to house amongst our customers, representing that the natural gas was just as good for illuminating purposes as the artificial. This plan met with considerable success. The method they employed was to shut off our gas, disconnect the meter, connect the riser to the natural gas pipe, remove the burners and put in their place the Jumbo burners. We lost for a time by these means some 500 consumers. Nearly all the stables, workshops, cellars, small stores and other places, where a good light was not an absolute necessity, adopted the Jumbo burner, which is a common flat flame, consuming from 10 to 50 cubic feet per hour. Apparently the natural gas companies made no conditions, for the consumer uses these

burners night and day for the sum of 15 cents each month. For a heating or cooking stove, which consumes about the same amount of gas, the companies receive \$1.50 per month. During the hot weather the heat from these large burners is very oppressive, but a number of people are willing to put up with a little discomfort of that kind for the sake of cheapness. As we anticipated, we lost our entire day consumption for cooking and heating purposes. There was no competition. It was a clean walk over the course with natural gas. It burns just as well in a common gas stove as our gas does. The stove requires no alteration whatever. Where the gas stove is not connected with the natural gas it is carefully put aside for future consideration. As some of you know, we had by some energy and perseverance built up a remarkable stove consumption; fully 10 per cent. of our output was used for cooking and heating purposes. Therefore we gracefully yielded to the inevitable. In other words we could not help ourselves.

Numerous devices for carbureting the natural gas, and thereby increasing its illuminating power, were experimented upon and brought out by a number of hopeful inventors. But, from some cause or other, these inventions have not proved successful. The gas thus carbureted was consumed in an Argand burner, and the fluctuations of the flame were very marked, arising either from the alteration of the specific gravity or from uncontrollable pressure. There was also some danger and trouble in handling the carbonizing material. These causes, with the liability of the chimneys to break from the intense heat, proved fatal to the success of this plan, for, I observe, in these days the people desire to have their artificial light with as little trouble as day light.

Natural gas has proved a veritable godsend to the Welsbach lamp. As you are all aware, this burner is of the incandescent order, and only requires heat for its successful operation. On the introduction of natural gas a company was immediately formed for the sale of this lamp. They charged \$2.50 for putting it in position. The gas cost 25 cents per month for each burner. It is claimed that the company sold 3,000 at these figures. This method of introducing the lamp did not apparently prove a financial success, for the company gave us several opportunities to purchase the sole right to use it. Our chief reason for declining to purchase was, if it was a good and cheap burner, we did not desire to place any obstacle in the way of the people having the full benefit of it. Recently one of the natural gas companies (the Consumers Gas Trust) bought the Welsbach people out, and the lamps are now being put in free of charge. They rent them for the average sum of \$2 each per annum. The gas is included. The conditions are that the contract is to be of one year's duration and the lamp to be returned in good condition, the consumer paying for all renewals and broken chimneys. The lamp gives a beautiful, soft, white light, and is well adapted for desk purposes where the person can get near enough to it, for, like all other incandescent lamps, it is very deficient in diffusive power. Much disappointment has been experienced by placing one on the usual store pendants. It requires two, and in some instances three, to diffuse the same amount of light as a common 6-foot jet of 18-candle gas, and at the exceedingly low price at which they are offered the consumers can afford to put up a sufficient number of them. There must be from 7,000 to 8,000 of these lamps in use at present; but it must not be understood that they have displaced a like number of our lights. At least one-third of that amount are being used by people who never burned gas before. No meter is used for these lights, and no limit is placed to the number of hours burning. Like all human inventions, the lamp has its drawbacks. The mantles require to be renewed once a month. The chimneys have to be kept clean, which, if neglected, reduces very materially their illuminating power. There are some other burners in this fruitful field, but I have only mentioned those that may fairly be called competitors.

In conclusion, it may be asked, What have we done to meet this extraordinary competition? We have done nothing more than we have always done these many years—sending out a pure 18-candle gas at as low a price as we could, cheerfully taking out a meter at the request of the consumer, and as cheerfully putting it back again; promptly attending to the wants of our customers, and treating them the best we knew how.

The law of compensation to some extent comes in here, as in other cases. Natural gas is an ideal fuel. We use it entirely under our benches and boilers, with a consequent reduction of labor. We sell our coke at a fair price in those benighted localities that are less favored by nature than we are, and with a reasonable price for our other residuals we manage to put our gas into the holder at a satisfactory figure. The great advantages of natural gas have brought increased business to the city, of which we receive a share of the benefit; and I think it a remarkable circumstance, and speaks well for the vitality of our industry.

that amidst this keen competition—cheap oil, a well-equipped arc and incandescent electric light plant, and a natural gas company giving its gas free for lighting purposes—we not only hold our own, but we actually sent out 700,000 feet more gas last month than we sent out the corresponding month of last year. We feel it is an advantage also that our people are being thoroughly educated in the use of gas for lighting, cooking, and heating purposes; and when natural gas fails, as I believe it will do in a few years at most, there will be an unresisting demand for the manufactured article to take its place.

Discussion.

The President—We are much indebted to the authors for these contributions. The papers are before you for discussion.

Mr. H. T. Gerould—When was natural gas introduced in Indianapolis?

Mr. Somerville—Two years ago.

The President—I think Mr. Cowdery's paper answers some questions, asked yesterday by Mr. Lansden, when Mr. Chollar's paper was under discussion.

Mr. Lansden—What Mr. Cowdery says with regard to mixed gases coincides exactly with my experience. I do not find any test that he has made which I have not myself verified.

Mr. Ramsdell—I would like to ask Mr. Cowdery what his system of radiation is—whether through ordinary radiators or through the pipe system.

Mr. Cowdery—Through four lines of 1½-inch pipe running around the room close to the base-boards.

Mr. Ramsdell—I tried some experiments with the same system exactly, and with just about the same result. I think my figures were 7 cents per thousand for heating.

Mr. Somerville—I would like to ask Mr. Cowdery if he took any unusual precautions to save the heat from going away; or was it, for practical purposes, just the same as anyone would use it for heating water?

Mr. Cowdery—Just the same as a person would use in it the house in an ordinary gas stove for heating water, only I took as good a type of gas burner as I could find. I took no unusual precautions to save the heat.

On motion of Mr. Forstall the thanks of the Association were voted to Messrs. Cowdery and Somerville for their papers.

A BATCH OF INVITATIONS.

At this point the Secretary read letters, from the Municipal Electric Light and Power Company, and from the Ringen Stove Company, inviting the Association to inspect their respective plants. After a vote of thanks for the invitations had been adopted, Mr. John Dell announced that those interested in the Coze system of inclined retorts could witness a good working specimen of the same in operation at the Howard street works of the Laclede Company, and added that he would be very pleased to explain the system to those who visited the works.

Mr. Eugene Printz, of Zanesville, Ohio, next read his paper, entitled **WROUGHT IRON, CAST IRON OR STEEL—WHICH IS THE BEST MATERIAL FOR STREET MAINS?**

In answering this question, are there not many others to be taken into consideration? The particular purpose for which the main is to be used; the kind of soil in which the pipe is to be laid—that is, does the ground contain any chemical combination that might be more detrimental to one kind of pipe than to another; has the pipe in its manufacture been so made as to be able to resist the action of the destructive agents that may be on the ground? Then, again, the cost of the pipe and the figure at which it can be placed in position, and the cost of maintenance thereafter, are serious matters for consideration. Which, if either kind of pipe, will give the least percentage of gas unaccounted for?

Wrought iron mains have some advantages not possessed by cast iron; owing to its greater strength, it will resist heavier internal pressures; less liable to fracture by sudden jars or by the disturbance of its foundation; can be joined together with less expense and greater speed; has fewer joints and can be laid in some situations where it would be almost impossible to lay cast iron; but it has two disadvantages considered serious ones—the first cost of the pipe and the limited life, as claimed by the friends of cast pipe, when compared with cast iron in many kinds of earth.

In making comparisons as to the cost between wrought iron screw-jointed pipe and cast iron pipe, I have figured as to the price by car loads delivered in Ohio. One mile of 6-inch wrought iron pipe would be \$3,485. One mile of 6-inch cast iron pipe would cost \$1,930, a difference in favor of the cast iron pipe of \$1,555 per mile. One mile of 8-

inch wrought iron pipe would cost \$5,710. One mile of 8-inch cast iron pipe would cost \$2,700, a difference in favor of the cast iron pipe of \$3,010 per mile. The labor for digging and refilling trench would be at least 25 per cent. in favor of the wrought iron pipe, as a trench much less in width will answer the purpose, and no bowl or bell holes are required. The labor, lead and yarn necessary to lay and join 8-inch and 6-inch cast iron pipe would be about \$400 for the one and \$300 for the other per mile, while the labor and paint cement to join a mile of 8-inch and 6-inch wrought iron screw pipe would be about \$150 and \$120, respectively—making a difference of \$250 for the 8-inch, and \$108 for the 6-inch, per mile, in favor of the wrought iron pipe.

The labor figures and cost of pipe on the wrought iron pipes are based on the supposition that screw-joints and standard weight pipe are used. If the patent leaded joint with the light weight wrought iron pipe is used the difference in the labor and lead account will be very much increased in favor of the wrought iron pipe over that of the cast iron—there being a saving in lead alone of 2,800 pounds for the 8-inch, and 2,100 pounds for the 6-inch pipe per mile; and as the pipe is so much less in weight, and a less number of joints to be made, it can be handled and laid with less labor and with greater rapidity.

It is claimed by those who advise the use of wrought iron pipe, and they have strong evidence to substantiate their claims, that there is less leakage, in fact a very large percentage less, than when cast iron is used: this we must admit would naturally be the case, owing to the more porous character of cast iron; but why there should be less leakage at the joints, only in proportion as there are fewer of them, we fail to understand; a joint that is gas-tight ought to be as good with one kind of pipe as with another. But it is urged that it is impossible to make a lead joint with cast iron pipe that will remain tight; that with the continual expansion and contraction of the pipe, although the movement may be very slight, will, with the rough surface of the spigot end, soon start the joint to leaking; and that with a lead joint on wrought iron pipe this is not the case, for the reason that while the movement may be greater, the surface of the pipe is smooth—sliding easily back and forth, without tearing or disturbing the joint.

Mains have been made of cast iron ever since the general introduction of gas for illumination (nearly three-quarters of a century), and when examined or removed are found, with the exception of a slight coating on the outside, to be, as far as the texture of the iron is concerned, in as perfect condition as if just placed in the ground. There are, of course, exceptional cases, but not many, where the ground has become impregnated with some foreign matter, which will and does act on and destroy the cast iron in a comparatively short time.

My own experience with cast iron for mains is limited to that of pipe, at present, used at my home. Some of it was placed in position 41 years ago. We are at present, and have been every season for the last 10 years, replacing the old lines with larger ones, and using the old ones again on streets where their size will be sufficient. To be sure, we find many pipes that are imperfect in their construction, but the iron itself is as sound and perfect as when first cast.

We have but very little wrought iron pipe in use for street mains—one short section of 3-inch, about 400 feet long, which has been down 10 years. It formerly did duty to convey gas on a bridge; it was at that time protected from the weather, and kept well painted; last week we had occasion to tap it for a service connection, and we found, to our surprise, after the 10 years' duty, it was in perfect condition.

As a means of comparison in the life of wrought and cast iron (when neither is covered with a protective coating, and is equally exposed to a very severe test), I will cite an actual experience which happened on one of the short streets in our city: On this street was a 2-inch cast iron main, with a number of service connections all three-quarter inch except one (an inch-and-half) which conveyed gas to a machine shop; going south from a certain cross street there was no difficulty whatever; but north from this point we were compelled to renew the service pipes every two or three years. Now, for the cause of this trouble: For a number of years this portion of the street had carried as surface drainage, the sulphur, or commonly called "copperas" water from several coal mines. The street was paved with limestone, the spaces between the stone filled with sand, but not cemented with tar or pitch. The drainage from the coal mines percolated through the sand and saturated the ground, which was composed of a mixture of clay and gravel, in which the 2-inch cast iron main was laid. In 18 years the texture or composition of the pipe was so changed or destroyed that the pipe, on being removed, was so soft that it could be shaved with a common pen-knife as easily as the plumbago in our lead pencils; there was not strength enough in a 7-foot length to carry its own weight when placed upon supports at the ends. You will notice the life of cast iron pipe as

compared with wrought in this instance, after making due allowance for the difference in the thickness of the metal, is as $3\frac{1}{2}$ is to 1.

On another street we have two short lines of 2-inch main,—one a cast iron and the other a wrought. The cast iron has been in 20 years and is in fair condition; the wrought iron has been in only 15 years and will of necessity have to be replaced in a very short time.

In this connection I will quote a few lines received from Mr. Cantine, of the Alliance Gas Light Company, Alliance, Ohio. He writes as follows:

"We had a 4-inch cast iron pipe leading from our main line through the Pennsylvania Railroad Company's yard to supply their ticket office and eating house; and, that after having been laid some 6 or 8 years, we found it leaking badly. This pipe was extra heavy and of sufficient weight to be known as water pipe. The ground in which it was laid was mixed with cinders from locomotive ash pits. The action of the impurities in the cinders had rendered the pipe utterly worthless, it having no more strength than unburned clay. The process of decomposition is or would be much more rapid in wrought iron or steel than with cast metal. The contact of one cinder no larger than a walnut will eventually eat its way through any pipe."

I have called attention to these instances, in a measure, in the first two, to compare the life of the two kinds of pipe under the same circumstances, and in the first and third to show that even cast iron may be readily destroyed when subjected to certain conditions.

Will not the question be asked, Why is it, that one kind of pipe will last so much longer in the same kind of earth than will the other kind of pipe? A gentleman to whom I put this question, suggested: Is it not that cast iron and wrought iron are different in their construction, different in their chemical formation? In cast iron, the particles of iron of which it is composed retain their crystalline or natural shape, and contains a proportion of carbon; these crystals are in nature hard, bright, and in a measure polished, and are more or less coated with graphite, depending greatly on the quality of the iron; all tending to preserve the metal from oxidation. In the manufacture of wrought iron a portion of the carbon is eliminated, rendering the metal softer; the crystal or natural form is broken up; the crystals are elongated or drawn out, presenting a stringy or fibrous appearance through the length of the metal. The graphite coating or protection of the crystals is removed, rendering the pipe more open to the action of the destructive agents.

Again: The question is asked, Why will the same kind of pipe last longer in one formation of earth than in another? Have you not noticed when your pipe, particularly cast iron, was buried in sand for a number of years, that a thin, hard coating impenetrable to almost anything, had formed on the outside of the pipe? This coating forms to a certain thickness; there the decomposition stops. Nature in this case has provided a nearly perfect and perpetual protector. Is not this combination of sand and iron, which is almost like glass in its hard appearance, silicate of iron? And have you not further noticed, that where this formation does exist, there is no escape of gas unless it be at the joints—the coating forming a gas-tight covering.

On the other hand when your pipes of either kind have been buried in white clay, the tendency has been to deteriorate, in many cases, quite rapidly. Can we not account for this in this wise? In nearly all cases white clay veins or banks are overlaid with coal in some form; sulphur, in solution from the coal, saturates the clay, comes in contact with and surrounds the pipe; the sulphur having a strong affinity for iron, combines with it; sulphuret or sulphide of iron is formed and the pipe is destroyed, more or less rapidly, in proportion to the amount of sulphur. This same action takes place where the pipe is exposed to coal cinders, similar to the case referred to in the quotation from Mr. Cantine's letter,—there the free sulphur in the cinder combining with the iron.

Again: If your pipe is laid in ground so situated as to absorb, or in any way to contain matter likely to ferment, near by, or in contact with the pipe, there is great danger; for, during the process of fermentation, carbonic acid is evolved. This acid is particularly destructive, and very persistent in its combination with iron; once it takes hold it never releases its grip until it has accomplished its purpose. An example of the action of carbonic acid on wrought iron is very clearly shown by the rust or pitted spots on the sheets of our gas holder. We notice first a little yellow dust; the carbonic acid of the atmosphere has combined with the iron forming carbonate of iron. This dust, in a very short time is oxidized, gradually becoming more red in color. In the meantime, the carbonic acid has moved on, and is working on the way to new iron, which it will continue to do as long as there is any iron to be found. We have often wondered why it was that after cleaning and painting the sheets of our gasholders, that in a few months we would find indications of rust, and that, too, right under the protective (as we supposed

covering of paint; but the carbonic acid was surely there and you cannot remove it, unless you scrape right down into the clear iron; every particle of rust must be removed before you can hope to be relieved of this troublesome destroyer of iron.

While not exactly germane to the question we have before us, yet bearing in that direction, I have thought it might be of interest to some of our members to examine a section of 6-inch wrought iron pipe which I submit for your inspection. This piece of pipe was in use just 2 years and 7 months as a stand-pipe to convey the gas from the retort to the hydraulic main. You will observe that it is completely used up. In the same gas works there are cast iron stand-pipes that have been in service for over 30 years, and from all appearances are good for another 30 years. I think you will agree with me in the statement that there is one purpose for which it is surely best to use cast iron pipes.

When the question is asked, "Which is the best material for street mains—cast iron or wrought iron?" we would likely answer at once, cast iron. Why? Because we have been accustomed to purchase the same for a great deal less money; it is cheaper, and it will last longer; and then we say again we have to renew our wrought iron services, and we do not the cast iron mains. Have we not overlooked the fact that the wrought iron services are less than one-half the thickness of the cast iron mains; that where we have had occasion to make renewals, the wrought iron had been more exposed than the cast iron. The services mostly gave out at gutter crossings, where the pipe was not of sufficient depth, and was exposed to air, and dampness, and frost. Is it not true that many of us have wrought iron services in use to day, and in good condition, that were connected to our cast iron street mains, when gas was first introduced to our towns, 40, and in some cases, 60 years ago. We know what to expect as to the lasting qualities of cast iron pipe. We know that with cast iron mains the leakage of gas will average as much as 10 per cent. This we gather from the reports received from a majority of the gas companies.

Now, we will see just what is claimed and we may say proven as to the lasting properties of wrought mains; also, as to the leakage where they have been used.

From Mr. J. B. Overton, Virginia City, Nev., we quote as follows:

"I have to say, that the 10-inch lap-welded pipe furnished by you appears to be as good to-day as it was when first put down in 1875. The light 18-inch pipe which I bought of your company in 1876, has been in constant use, and has given no trouble, nor has it cost a cent since laying."

Under date of November 14th, 1882, we have the following:

"Gents—In reply to yours of the 9th inst., inquiring about the lasting quality of wrought iron pipe for gas mains, I would say: We put in some wrought iron main in 1858; before laying it, we coated it with tar and let it dry in the sun; used tar on the threads and couplings freely, mixed with sand. In 1874 we had some of the same mains taken out, being too small to supply the consumption. In all cases the pipe was sound and clean; all we had to do was to re-tar it and then re-lay it in other streets. We now have in use over 8 miles of wrought iron pipe from 1½ to 4 inches in diameter, and all of it giving the best of satisfaction. Our leakage account will compare more than favorably with any other works, and we claim that wrought iron pipe is the cause of it." (Signed, THOMAS BUTTERWORTH, Rockford, Ill.)

The following is a telegram from Mr. O. P. Shaffer, Treasurer Standard Gas Light Company, New York City:

"We find wrought iron gas mains practically stop all leakage; only leaks we have are on cast iron crosses and sleeves; leakage in cast iron lines in this city averages 14 per cent.; ours does not exceed 1 per cent."

Mr. W. W. McCleary, Superintendent Gas Company, Braddock, Pa., writes the following:

"Our whole gas system is composed of the Converse light-lock joint wrought iron pipe. Is giving perfect satisfaction; less than 1 per cent. leakage."

The following extract accompanies the sample pipe from the McKeesport Gas Company:

"I send you a section of 4-inch O. D. line of our special wrought iron gas pipe, which was laid by me in 1875. We took it up in September, 1887, and found it in as perfectly serviceable a condition as when it was put in the ground. I must say it was a surprise to me to find it so perfect. Cast iron could not have made such a record under similar circumstances. I have taken up cast iron pipe from the same soils here, which had not been buried for nearly so long a time, and the result has been just the reverse of this. Our soil is a very severe one, and the showing in this case proves durability of your coated wrought iron pipe." (Signed, W. C. NEEMES, Supt.)

I have here a report from Mr. C. E. Manly, Chemist:

"The following is my brief report relative to a piece of wrought iron taken from a 9-mile line of 22-inch riveted pipe, working under a head of 530 feet, and having been in the ground 13 years at the mines north of San Francisco. Sample submitted by Mr. T. W. Brooks.

"On making my inspection of this piece of iron I find it is in good condition and as perfect as any piece of iron just newly rolled. The iron is smooth and has a uniform gauge of No. 11. I notice there is not a particle of rust to be found adhering to the iron. This state of preservation is undoubtedly due to the protection of prime asphaltum coating. That metallic iron will rust in contact with water, which latter contains free oxygen, air, or carbonic acid gas, nature demonstrates every day; and no matter how perfect the iron may be, yet oxidation will show itself sooner or later upon unprotected iron, especially with cast iron, due to the impurities therein. These impurities amount to 100 per cent. of the bulk of the cast iron, due to the graphite, silicon and sand; and it is therefore possible for the entire iron to be dissolved out whenever galvanic action exists, in patches destructive to cast iron; the result is a mere shell of graphite and silica, representing the original curve and thickness of the pipe. With wrought iron, this peculiarity of galvanic action is unknown, due to its purity and absence of crystallization; but to insure perfect safety, means are taken to prevent any disaster of this kind, defecting even to a small degree the surfaces of wrought iron, by the use of asphaltum or any hard surface impervious to moisture. We have 14 years' experience to substantiate the above statement, and as the iron does not show a sign of blemish after the 14 years' service, I consider it will be found in as good condition 100 years hence as it is to-day." (Signed by C. E. Manly, Chemist.)

Is it not a serious question, "Which is the best—wrought iron or cast iron for street mains?" The wrought iron costing, in the first place, from 50 to 100 per cent. more than does the cast pipe. (This difference is greatly reduced in proportion as you get further away from the points of manufacture. The freight rates—a very important item—being very much in favor of wrought iron, as the same car will carry many more feet of the light wrought iron than it will of the heavy cast pipe.) The wrought pipe does not cost near so much to lay, and the saving in leakage will in a very short time balance the extra expense for the wrought iron pipe. The most important question appears to be, Will the wrought pipe last? On the other hand, why not have our cast iron pipe, which we think, under ordinary circumstances will last, properly coated with some material that will close the pores and protect the iron beyond a doubt; also, have the spigot end of the pipe turned or ground smooth, so that a permanent and tight joint could be made. This certainly would not add a great deal to the price of the present cheaper pipe, and you would save quite a large percentage on the outlay.

Steel Mains.—Engineers and experts are of the opinion that to weld, or properly join two pieces of steel, requires that blows as with a hammer should be given; that they will not join by being rolled or crushed together, as will wrought iron, for the reason that the fiber is too short; that the two surfaces merely stick together as with a flux, just as two boards are glued together one upon the other.

In welding wrought iron pipe with the machinery constructed for the purpose, the long fibers of the iron are firmly interlaced and joined—the joint or weld being as firm as any other portion of the pipe. I have here a sample of welded steel pipe which I hope you will examine.

Again, it is claimed that steel, being short in the grain, gives a great deal of trouble by fracturing near the joints at the threads. For these two reasons it is not considered advisable to use steel mains.

Converse Joint.—Our worthy Secretary intimated to me that a word in regard to the Converse jointed pipe would likely be of interest. Not knowing anything of it personally, I visited the shops of the manufacturers to learn how it was made, what it was made of, and to see a joint tested under pressure. The joint I saw tested was made in my presence—two short lengths, about 4 feet each, of 6-inch outside diameter pipes (the thickness of the metal was not quite ½ inch), were joined with the short sleeve used in this style of joint—no yarn or tarred rope was necessary—just simply slide the ends of the pipes in the sleeve, give them a slight turn to tighten the lock, then the usual clay roll, pour in the molten lead, caulk the joint in the usual manner (which appeared to be very easily done, as there was not the old-time yarn cushion); the lead was driven solid against the iron, and did not consume so much time as the ordinary joints for cast iron pipes. After the completion of the joint the open ends of the pipes were closed with bolted blank flanges, the pipe laid loosely on trestles, a force pump with pressure gauge was connected to an opening in one of the pipes, and water forced in; a pressure of 500 pounds to the square inch was raised, and allowed to remain for some time, without a sign of leak at the joint. This was

a thrusting strain of 14,000 pounds to force the pipes asunder. The pressure was then raised to 800 pounds per square inch; one of the pipes at this began to slide out from the sleeve; and the joint to leak slightly. I asked that the pressure be reduced and the lead re-caulked, which was done and the pressure again raised to 300 pounds before a leak was started. Again the pressure was raised to 850 pounds per inch, or a thrusting strain of 22,800 pounds, to part the joint.

During my investigation I learned the pipe was manufactured of the best grade of wrought iron, similar to that used in the manufacture of boiler tubes or flues. After the pipes have been tested for imperfections they are thoroughly coated inside and out by being boiled in a mixture called "kalamein." Kalameining consists in "incorporating upon and into the body of the iron a non-corrosive metal alloy, largely composed of tin." The surface thus formed is not fractured by blows, or by bending the pipe either hot or cold. The sleeve or coupling is made of the toughest and best grade of cast iron, and is boiled in paraffine to close up the minute pores of the iron. The outside of it, as well as the pipe, is then, if desired, coated again with asphaltum. By request, the manufacturers have submitted here for your inspection samples of the pipe and joint.

The Converse jointed pipe is used very extensively by a number of water companies and natural gas companies. Engineers of these companies, by their testimonials, freely given, speak very highly of it as being so well adapted to resist the high pressures and the unusual strains brought upon it by the slips on the mountain sides. They refer to it as giving less trouble from leaky joints than any other pipe they had ever used (not excepting the screw and jointed pipe).

An idea as to how much engineers appreciate the use of wrought iron for mains for water, manufactured and natural gas, oil, compressed air, and other purposes, may be imagined when it is understood that of the Converse jointed pipe alone there was sold in the eight years preceding January, 1890, pipe ranging in sizes from 22 to 24 inch, a total amount of nearly 7,000,000 feet, or nearly 1,300 miles.

The Laclède Gas Light Company, St. Louis, Mo., have, up to this time, placed orders to the amount of 18,000 feet of 12-inch, 12,000 feet of 6-inch, and over 6,000 feet of 4-inch Converse light lock-jointed wrought iron pipe.

The Philadelphia Natural Gas Company say:

"We have used perhaps 75 miles of the Converse joint pipe, and have found it first-class pipe in every respect. The joint is a good one, very easily put together, and after the line is connected the pipe is tight under a pressure of 250 pounds to the square inch. We do not carry this pressure, however, on our line in actual use, but test it up this high. We have just taken up considerable of this pipe from a field abandoned, and relaid it in a new field, and find it is just as good as the day we put it down, and as easily put together. In short, we take pleasure in saying the Converse pipe is all that is claimed for it by the makers." (Signed by T. A. Gillespie, General Superintendent.)

Friction.—From Prof. John C. Trautwine we have this opinion:

"As the Converse joint produces an absolutely smooth interior, reducing friction to a minimum, the increased flow and delivery of gas will be readily appreciated. The cast iron pipes themselves are not cast perfectly straight, or smooth, or of uniform diameter, and irregular swellings produce eddies and retard the flow. Under the most favorable circumstances, therefore, it is expedient to make the diameter of cast iron pipe, even for temporary purposes, sufficient to discharge at least 20 per cent. more than the quantity actually wanted; and still larger allowance should be made in permanent pipes. Natural and manufactured gas mains are usually for permanent lines."

From Prof. Haswell we quote the following:

"The difference in friction between a line of ordinary spigot and bowl-jointed cast iron pipe, and a line of seamless wrought iron pipe, with flush connections alike to the Converse joint, would be fully 25 to 35 per cent."

I have written thus fully in reference to this joint, not because it was my wish to foster or bring to the front any particular patent, but as there appeared to be an especial interest manifested in it, and as far as lay in my power to oblige our worthy Secretary.

Discussion.

The President—This is a most interesting paper, and Mr. Printz will be glad to have you question him.

Mr. Tracy—Once, when I had occasion to lay about half a mile of mains I was undecided whether I should lay cast iron or wrought iron pipe, but after taking up some wrought iron pipe that had been laid in my streets, I made up my mind I would not lay anything but cast iron pipe. The gasfitters and plumbers tell me that in less than four years

wrought iron pipe is so completely eaten up that they cannot do anything with it. On the other hand, some cast iron pipe which had been down for 40 years, upon examination was found to be in as good condition as could be desired; but the wrought iron pipe was completely eaten out. This pipe which I took out was taken out on account of being shut up by a drip.

Mr. Miller—I think that steel pipe is somewhat summarily disposed of in Mr. Printz's paper. I have had occasion to put in about four miles of steel service pipe in the past year, using pipe from an inch to an inch and a half. I have also bent some of it hot, and cold, for different purposes, and have given up the use of iron pipe entirely for our services. I find that the steel pipe is softer and cuts nicer. Hence you get a better thread, and can do better work with it. I have had no trouble with that as I have had sometimes with wrought iron pipe.

Mr. Forstall—Our experience with steel pipe is much the same as that of Mr. Miller. We have given up the use of wrought iron pipe almost entirely for services in sizes under two inches. All our pipes, up to two inches, are put in of steel. I find it cuts a better thread, makes a better joint, and does not corrode as fast. There has been no trouble from splitting.

Mr. Thomas—One statement in Mr. Printz's paper ought to be explained. He says:

"The following is a telegram from Mr. O. P. Shaffer, Treasurer, Standard Gas Light Company, New York city:

"We find wrought iron gas mains practically stop all leakage. Only leaks we have are on cast iron crosses and sleeves; leakage in cast iron lines in this city averages 14 per cent.; ours does not exceed 1 per cent."

I have always contended that the term "leakage," as usually employed, is a misnomer. It ought to be called unaccounted-for gas. There has been a great hue and cry in New York city of late, especially in the sections in which the subways have been laid, about gas escapes and gas explosions. It is claimed that the subways are little else than gasholders, and the subway builders and controllers claim to be at a loss for the reason of the presence of the gas in their oddly-built construction. Independent authority could easily explain its presence. The carelessness of the subways workmen, when "picking around" the gas mains, accounts for the leakage and escapes. Mr. Shaffer admits there has been a great deal of leakage from the crosses and sleeves of the Standard Company. The fact that there is such a leakage is evident to anybody who has ever been in New York city. Let me say again, in discussing this question of leakage in New York city, I have always claimed, as I claim now, that with pipe well laid the actual leakage therefrom cannot exceed three-quarters and possibly not more than one-half of 1 per cent. I think the total average loss, between generating house and consumers' burners, in New York city, does not amount to 14 per cent., and the unaccounted for gas can be practically traced so as to bring the main leakage down to less than 1 per cent. The Standard Company have been about 2 or 3 years putting their wrought iron pipe down, and I have never seen any place uncovered, where they had put their pipe down, that I could not smell the escaping gas. All the companies suffer alike in that respect. The upper part of the city is underlaid with rock formation, and in putting sewers through the streets (gas mains have frequently been laid in this section before the sewers were put down, and house drain connections are being constantly made) the blasters pay no attention to gas services or mains. Of course, this causes a great deal of loss. With the best quality cast iron pipes, in works that I have managed, we kept our leakage down to about 6 per cent.; and about 1 per cent. of that was chargeable to over-consumption in the street lamps. We uncovered cast iron pipes that had been in good ground for 30 years, only to find them sound and serviceable. Again, as stated by Mr. Printz, in made ground, or in low spots which had been filled up with coal cinders, coal lime, etc., the pipe, which looked perfectly good in the trench, could be cut through with a jack-knife. Our wrought iron services had to be renewed about every seven years. In my experience, in uncovering pipe that had been laid by my predecessors, I found they had used small pieces of wrought iron pipe, to make what we term a "spring," in the top of the main, and I invariably found that they would leak by reason of stretching of the iron. I adopted what I termed the "brass spring," made with a nipple to screw into the main and a socket for the service pipe. After they had been in use for 20 years, and changes had to be made, they have been removed and used in other places. I suppose if in New York the pipe was permitted to rest in the ground as it ought, the main leakage all over the city would not exceed one-half to three quarters of 1 per cent. Gas was introduced into New York city about the year 1824. It has been claimed that the leakage has amounted to about 25 per cent., and that from 1824 up to the present time, that leakage has been stored in the

ground. In laying the subways they put in a bed of cement then place the pipe, next put in another bed of cement, then lay another layer of pipe—they lay three or four layers of pipe and of cement together. Then the pipes are led into manholes, which are built of cement and brick, and made perfectly tight, and there they seal them up as they would seal a preserve jar, yet you cannot go along the street at night without noticing the escape of gas from them.

Mr. J. B. Howard—Some 5 years ago we had occasion to renew our mains for about three-quarters of a mile. The pipes were mostly 6-inch and partly 4-inch. We replaced them with 10 inch. The pipes had been in the ground for 34 years. In looking at the services as they were taken out I noticed that in the black loamy soil, although the pipe had been laid for 34 years, it was still just as shiny in appearance as when first laid, with no deterioration whatever. In sandy soil, mixed with clay, the deterioration was somewhat greater, and in soil that was of pure sand we found the deterioration in some places to be considerable. In fact it was really a wonder how the services had remained tight; but they had. The pipe was coated over with quite a considerable substance of sand, which had become hardened at certain portions of the pipe length. When we knocked that off we found holes in the pipe at the particular spot where the hard substance had collected. We have some pipe in other parts of the city that has been laid over 30 years, and which I have had occasion to tap once in a while—it is a 2-inch wrought iron pipe, and lays on hills where the pressure is great. I have found on tapping it, to put in $\frac{3}{4}$ -inch connections, that it is just as sound to day as when it was laid. It is of course somewhat discolored, but there does not seem to be any deterioration. This, I think, is due entirely to the peculiar nature of the soil. As to the durability of wrought iron pipe, I think that depends altogether upon the locality where it is laid.

Mr. Egner—I am not authorized to speak for Mr. McMillin (some of you may be pleased to hear that he has arrived safely on the other side of the Atlantic), but I will say when we undertook to readjust our mains, Mr. McMillin (who is the President of the Company, and an able gas engineer, as you all know) called his heads of departments in consultation and he remarked that he would not lay any cast iron pipe over certain sizes. We were about to lay $3\frac{1}{2}$ miles of main from one of the works to the station, to be used just for pumping gas from the works to that station. We decided to try wrought iron pipe. We have laid most of that now. I know that after a little more than a mile had been laid we put the pressure on this pipe with a Westinghouse air pump, up to about 10 pounds per square inch, in the evening, and let it remain so until the next morning, and it did not seem to have leaked any. As to the relative cost and durability I can only speak from hearsay; but I know that Mr. McMillin seems favorably impressed with it, and has determined that we shall not lay any more cast iron pipe of less than certain sizes. I simply desire to tell you what we have done, and why we have done it, and what we know about it. I cannot speak about the durability, nor can I say anything about the cost just now; but I can say that what we did lay was remarkably tight.

Mr. Ramsdell—On that same topic I would say I was in St. Louis recently when this subject came up, and Mr. McMillin made the same remark to me that he made to Mr. Egner. He also stated recently in Ironton, Ohio, he saw some wrought iron pipe taken out which had been laid 17 years before, and that the pipe was in an almost perfect condition. I got an impression from what he said about it that that had something to do with his decision.

Mr. Lansden—I may say, for the benefit of those who may want to test this question, that sixteen years ago I acted as engineer in construction of the works at Chippewa Falls, Wisconsin, and that we laid wrought iron pipes in sandy soil. I know nothing about how they have lasted, but those desiring information can ascertain by writing to the works. I laid wrought iron pipe entirely.

Mr. Tracy—I would like to ask Mr. Printz if, after looking at that pipe, he would advise me to lay half a mile of 3-inch wrought iron pipe.

Mr. Printz—I would not advise you to lay 3-inch wrought iron pipe unless it was protected from the impurities in the soil. You certainly have soil there of a nature that would be destructive to wrought iron pipe.

Mr. Tracy—My specimen example was not taken at one special place, but from different parts of the city. I find it on the hills as well as in the low places; and my services I find are in the same condition. I am protecting my services with a coating of two-thirds tar and one-third naphtha, mixed together. I paint them over with that, but whether it will eventually preserve them or not I do not know.

Mr. Odiorne—A great deal of leakage is attributable to the joints. I use lead joints, and find that they are perfectly tight. If there is too great a strain on the pipe it will break square off before the joint will

give. I think if Mr. Tracy is obliged to use cast iron pipe, it would be a good idea to investigate the cement joints.

Mr. Tracy—I have used cement joints for years. I use four parts of cement to one of lead—I use one of lead for expansion—and never have any trouble with the joints.

Mr. Scofield—Some years ago I adopted the plan of laying my pipe during hot weather, in the summer, and coating them with coal tar, and I find that it makes a thorough coating, and is a real protection. I have taken up pipe which has been down for 12 years, and I find the coating as perfect as when it was put down.

Mr. Printz—I think our President has had some experience with the use of wrought iron pipes. I notice he has coated wrought iron pipe with coal tar, heating the pipe by passing steam through it, and then coating with tar. I saw his services put down in that way.

Mr. Somerville—I think you will remember that in Cincinnati all the stand-pipes were of wrought iron; and anyone here who is connected with that works would oblige me by telling how the stand-pipes have stood. I have been laying wrought iron pipes for 20 years, and they are still just as good as new. I do not see why stand-pipes should be affected in that manner by crude gases, for the same crude gases have to go through the hydraulic mains as well as through the stand-pipes and through the scrubbers; and yet you know that the scrubbers last as long as most of us wish them to.

Mr. Forstall—I cannot give Mr. Somerville any information about Cincinnati, but I can say that in Chicago we have wrought iron stand-pipes that have been in use for 6 years; and the last time they were taken down, when we reset the benches, they were apparently as good as new. We have used the same stand-pipes right straight ahead, and have not had to renew any of them.

Mr. Lansden—I will say that the Company I am connected with tried wrought iron stand-pipes for several years. We had a good deal of trouble immediately at the mouthpiece. Five or ten per cent. of them would have holes formed within 18 or 20 inches of the mouthpiece. We are now putting in cast iron entirely whenever one of them gives out.

On motion of Mr. Tracy the thanks of the Association were voted to Mr. Printz for his excellent paper.

APPOINTING THE SPECIAL COMMITTEES.

The President—I desire to announce the appointment of the following special committees:

Committee of Arrangements, Louisville Meeting.—Messrs. A. H. Barret, Jas. Somerville and Geo. H. Wells.

Committee on Place of Meeting, 1892.—Messrs. Geo. G. Ramsdell, J. B. Howard and Irvin Butterworth.

VOTES OF THANKS.

The President having announced that the regular business order had been finished, Mr. Lansden moved that a hearty vote of thanks be passed to the President for the able manner in which he had directed the meeting. The motion was seconded by Mr. Tracy, put by the Secretary, and adopted unanimously amid great applause.

In reply to the compliment, President Faben said: Gentlemen, I can simply say that I thank you. It was with great misgiving that I attempted the task. If my efforts have pleased you I feel more than rewarded by the happy manner in which you have recognized them.

Mr. J. B. Howard—If we were to leave this room without thanking our worthy Secretary we would be very remiss. I, therefore, move a vote of thanks to our worthy Secretary for his indefatigable attention to his duties.

The resolution was adopted by rising vote, and Secretary Littleton responded in his usual clever fashion.

REPORT OF COMMITTEE ON RESOLUTIONS.

The Secretary read the following report from the Committee on Resolutions:

Mr. President and Gentlemen of the Association: Referring to the programme (which, by the way, is in itself a work of art), your Committee find the names of the Committee of Arrangements, also the names of the Reception Committee—we will not undertake here to enumerate the names of the committees, but will quote the concluding sentences of the programme, which are as follows: "The various entertainments are given with the compliments of the above named gentlemen and the concerns which they represent." Those of us who have been in St. Louis on occasions similar to this before, know something of the hospitality and entertainment that can be developed here. The programme and the names of the committees would lead to the belief that the old spirit still lives, and that this gathering of the Western Gas Association will have occasion, as in former times, to carry to their homes many pleasant mem-

ories of the 13th annual at St. Louis. We, therefore, propose that the hearty thanks of this Association be tendered to the Committees of Arrangements and Reception and the concerns which they represent.

EDWARD LINDSLEY,
WALTON CLARK.

On motion of Mr. Jenkins the thanks of the Association were voted to the Committees of Arrangements and Reception, as proposed in the report.

The convention then adjourned.

Modern Measurements.

Our English contemporary *Invention* remarks that the progress of measurements in modern times was aptly illustrated in an address recently delivered before the Engineers' Society of Western Pennsylvania, as reported by the secretary of that society. Progress is to-day, he said, written upon every page of the world's record, and particularly in the realms of science is it making its unmistakable mark, from thence extending outward to the vast range of correlated studies that go to make up the sum of human knowledge and economies. In astronomy and astronomical engineering, in physics and chemistry, in civil and mining engineering, in meteorology and in metrology and in mechanics, to say nothing of many other branches of science, do we find progress as the watchword and the theme that excites and moves the human brain to grander and better achievements. The day has forever passed when we are willing to say or believe that "three barleycorns make one inch." Nor is the advanced mechanic of to-day satisfied with his boxwood rule, graduated to thirty-seconds of an inch, save for the coarsest approximate measurements; but he must have his standard graduated to $\frac{1}{100}$ inch for his coarse measures, and his micrometer gauges reading to $\frac{1}{1000}$ for ordinary work. Even in our iron and steel works, the old-time wire gauge, that for a long time held its own, has been displaced by the micrometer gauge of infinitely greater accuracy.

Prof. Wm. A. Rogers has shown that many of our modern mechanics can caliper to $\frac{1}{30000}$ of an inch. These, however, are coarse, rough measures when compared with others that may be mentioned. In the domain of astronomical measurements great progress has been made of late years; by the use of refined instrumental means, as well as the many methods devised for the elimination of instrumental errors, divisions of the meridian circle have been brought to astonishing accuracy.

The various enlightened and civilized nations have standards of weight and measure that have slowly been evolved from the cubit, the span, the finger length and the barleycorn, if you please.

Nations have their standards. On what are they based? The French meter is presumed to be $\frac{1}{10000000}$ of the earth's quadrant, the English yard evolved from the barleycorn, etc., but the measurements of precision in our day demand an indestructible, absolute and unalterable basis for our standards, so that if they all be destroyed the original is still available. Prof. Michelson has chosen a wave length of sodium light as the basis for a new standard, a something that will remain forever of the same absolute linear value. Now a wave length of sodium light is, roughly speaking, about $\frac{1}{42000}$ of an inch long. Now, as this is an appreciable figure, it is evident that any method proposed to measure its absolute value must be of the highest accuracy. The method devised by Prof. Michelson in the refractometer has certainly brought the work to marvellous perfection. He has shown that the error was not greater than 1 part in 2,000,000, and possibly would be made not greater than 1 in 10,000,000. Gentlemen, can you appreciate such a quantity? Yet here is a physicist, with a high ideal of perfection, taking the pulsations that are sent earthward by the sun, and by methods within the reach of human skill, actually recording them upon a standard bar immersed in a freezing mixture, and giving us a universal standard based upon the absolute value of a wave length of light.

We have to thank Sellers, Bement, Warner, and Swasey and others, for their valuable contributions of metrology, and their standards of various kinds that have contributed so much to advance the mechanics in this country. The standard measuring devices made by Brown and Sharpe have become a power for accurate work. The standard gauges of the Pratt & Whitney Company now find an honored place in all high-class machine shops; and our American machinists are greatly indebted to the labors of Prof. W. A. Rogers and Mr. George M. Bond, who designed and carried into execution that wonderful instrument of precision called the Rogers-Bond comparator, from which has emanated many standard tools, and has assisted so largely in the introduction of interchangeable parts in American machinery. It is true that human brains must have a limit to their capabilities; but where shall we place

that limit? Watt gave us the horse power as the unit of measurement, Joule gave us the better one of the foot-pound unit; King Henry's arm may have served for the long measure, and the barleycorn for the short measure, but the meter and the micron are infinitely superior; yet we still hope for better standards, and are now reaching out for waves of radiant energy from which to make them, and which shall remain as constant as the universe, "whose builder and maker is God."

SPECIAL ENGLISH CORRESPONDENCE.

COMMUNICATED BY NORTON H. HUMPHRYS.

SALISBURY, June 10, 1890.

The Gas Institute.—The Labor Question.—Sulphur Recovery.—Improvements in Sulphate Apparatus.

The final programme for the Gas Institute meeting next week has just been issued, and affords even greater promise for the ensuing meeting, than I ventured to indicate two months ago. The list of papers comprises eleven, including almost every subject of current issue to the gas industry. Three papers deal with gasholder construction, one with stoking machinery, one with the labor question, one with inclined retorts, and the remainder with sulphate of ammonia, the extension of the gas companies responsibility to fittings beyond the meter, oxygenated oil gas, illuminating water gas, and the supply of electricity by gas companies, respectively. The proper discussion of all these subjects will fully and profitably occupy the time at disposal. The public part of the proceedings is on an equally substantial scale, comprising a smoking concert, a musical *soiree* with a dance afterwards, a visit to a rose show, an open air promenade concert and a steam boat trip around the Isle of Wight. Altogether the programme is the best that has ever been set before the members of the Institute, and reflects the greatest credit on all concerned in getting it together, and especially on the President, Mr. Geo. Garnett, who has had the lion's share of the work.

Amongst the matters treated in the report of the Council to be presented at the meeting, will be an acknowledgement of the kindness and courtesy extended to a party of some 120 members of the Gas Institute, by the French Gas Engineers, on the occasion of their visit to Paris at the close of last year's meeting. The Council will also give their reasons for wishing to incorporate the Institute as a limited company under the Companies' Acts. An extraordinary meeting will be held at the close of the general business, for the consideration of this question. Of the members removed by death during the year, special reference will be made to the late Mr. G. W. Stevenson, and the late Mr. Lewis Thompson. It is proposed that the Birmingham medal shall be awarded to Mr. Thos. Newbigging. The Institute now numbers 649 members of all classes.

The labor question has again come to the front in London, and this time it is on the North side of the Thames. In this case, also, the policy of the leaders of the laborers and stokers Union has been to promote distrust, antagonism and insubordination on the part of the men towards their employers. Mr. John West had fitted up a retort house at Beckton with his patent stoking machinery, and agreed with the Gaslight and Coke Company to work it for a time under his own superintendence. Having arranged all in readiness for a start, and engaged a gang of stokers, he was met by the refusal of the men to carry out their engagement. Acting under the advice of their Union, at the hour for commencing work, and not before, the men announced that they would not work unless paid 5d. a day more than the sum agreed upon. The object of this advice is not very apparent, seeing that the only difference it made to Mr. West was that it hindered him for an hour or two. There were plenty of men about who lost their regular employment at the strike at the South Metropolitan last winter, and were only too glad to get into work again. One of the leaders of the Union, in commenting upon the defeats experienced in Manchester and London last year, stated that the next strike would be a momentary one, and that the men would throw down their tools without notice, and take the consequences of breaking their engagements. If this was intended as a trial of such an illegal mode of action, the result must be anything but satisfactory to the Union, as neither the members nor the policy of the Union has been benefited in the least. Mr. West is now carrying on his operations satisfactorily with non-union men, but he has found it necessary to provide special accommodation for them on the grounds, and to have extra police protection. The necessity for this arises, however, more on account of the personal feelings of individual members of the Union, rather than for any organized plan of individualism; though it must be said that a Union that would not hesitate to instruct its members to defy the law in one way, is not likely to be scrupulous about breaking it in another, if it suited the purpose in view to do so.

The Union, to be consistent, ought to welcome and support anything in the way of retort house machinery, seeing that when appealing to public sympathy last year, a great deal was said about the sweltering atmosphere of the retort house, the necessity for working like madmen in order to escape the raging fury of the flames, and the work being so exhausting as to make a man old at the age of 40. They ought therefore, to publicly recognize Mr. West as a benefactor in trying to devise a practical remedy for such a wretched state of affairs. But actions speaking louder than words, and although they make great protestations about not being antagonistic to machinery, it is quite evident that they do not intend to facilitate its introduction in any way.

This matter, however, is only a little side skirmish. The main point of dispute is the fact that the Directors of the Gas Light and Coke Company are endeavoring to make such arrangements as shall preserve them from the misfortune that befell their neighbors last year, and which, besides costing some £50,000 or more, involved a great deal of inconvenience to the consumers. In this they are to be commended, as recognizing the irresponsibilities both to the consumers and to the shareholders, and seeking to meet them. But this, of course, does not suit the Union, who wish to get a grip upon every board of gas directors in the kingdom. Once possessed of such power they would not hesitate to use it on any and every possible occasion, and no body of employers would be safe for two days together. The Directors propose that every workman in their employ shall sign a monthly agreement. The first clause specifies that notice to terminate the engagement must be given on the same days of the month as that on which the agreement commences, in writing. The second provides for the summary dismissal of the workman without notice in case of drunkenness, neglect of duty, insubordination, or other misconduct. According to the third, the workman agrees to observe all instructions, rules and regulations issued under the authority of the Company; and the fourth agrees that duties shall be performed in a proper manner, at the customary rates of pay. The men are to be offered an opportunity, through their representatives, of discussing the terms of this agreement, and while not objecting to meet the men by modifications in details, the Directors must hold firmly to the main principles of the agreement as absolutely necessary to the proper carrying out of the undertaking.

The sulphur recovery process, by which is meant the precipitation of solid flowers of sulphur from any gas that is rich in sulphureted hydrogen, is becoming quite a recognized thing. It has already been adopted by the leading alkali manufacturers, and is rapidly making its way in large gas works, as a means of treating the waste gases given off during the manufacture of sulphate of ammonia. The general plan in small works is to pass the gases coming off from the saturator through an oxide purifier, whereby the sulphureted hydrogen is absorbed, and in a sense utilized, since the sulphur can be extracted from the spent oxide. Turned to account in this way, however, the cost of conveying the material to the chemical works, and other charges, leaves very little profit to come in from this source to the gas undertaking; and therefore the Claus kiln and settling chamber are considered to be preferable. In Lancashire, especially, the erection of sulphur recovery apparatus is proceeding with energy, and at a gas works in the Midlands, nearly 1 cwt. of sulphur is obtained for each ton of sulphate made. This represents $1\frac{1}{2}$ pounds of sulphur from each ton of coal. Various difficulties, that at first proved a great hindrance to the adoption of the Claus apparatus, are gradually being done away with, so that the next few years will see its general introduction, for it is simple, and when properly under control, automatic in its operations. A proper quantity of air is mixed with the waste gases, according to the proportion of sulphureted hydrogen present, and the mixture is passed into the kiln, which is simply a small chamber about a foot or so each way. Here the sulphureted hydrogen is decomposed with separation of the sulphur in the solid form. The latter is deposited in large condensing chambers provided for the purpose, from which it can be removed at convenient intervals.

The last few years have also seen considerable improvements in the apparatus for manufacturing sulphate of ammonia in gas works. The plain boiler, with which intermittent work only is possible, since it must be emptied when exhausted, and fitted with a fresh charge of liquor before a fresh start can be made, is gradually giving place to improved forms of still, several makes of which are in the market. In one respect these new stills all agree, and that is in being worked continuously. The liquor flows in without cessation, so long as the apparatus is at work; it may be for several weeks if desired. The whole process thus proceeds with perfect regularity. There is no need for the cumbersome overhead tank, large enough to hold the fresh charge for the boiler, or for a cooling tank to receive the exhausted charge. The liquor flowing in regularly, can be pumped direct from the store well as wanted, and as

the effluent passes off with equal regularity, a large stock of it at boiling heat does not accumulate, and it can be readily disposed of as fast as it is made. Recently an improved automatic discharger has been introduced, by means of which the sulphate is raised from the saturator to the draining board.

If this invention will work properly it is likely to be valuable, as at present one man's time is almost entirely occupied in fishing the sulphate out as fast as it is formed with a perforated bowl fixed to a handle; and the continual rubbing and scraping of the bowl on the bottom of the saturator wears out that part much sooner than would otherwise be the case. Steam has almost entirely replaced the open furnace as a means of heating up the liquor for distillation. Sulphate apparatus is also being introduced into the smaller sizes of gas works with advantage, and it is now no uncommon thing for a works carbonizing only 400 or 500 tons of coal a year to have its little sulphate apparatus. Under these circumstances 4 or 5 tons of sulphate can be made per annum at a profit of at least \$20 per ton, whereas formerly the liquor realized practically nothing.

Assay of Coal.

A contemporary, in a sensibly-prepared article on this subject, says that those who are prospecting after coal often have difficulty in determining to what class their finds belong. The principal varieties of coal are as follows:

Anthracite or hard coal—hardness, 2 to 2.5; specific gravity = 1.32 to 1.70. Contains volatile matter after drying, 3 to 6 per cent. Contains carbon 80 to 95 per cent. It has a high luster and burns without flame, as it contains little or no bitumen. It is totally devoid of impressions of plants, and is, geologically speaking, the oldest of all kinds of fossil charcoal, and is regarded as the last stage of carbonization. It yields from 1 to 7 per cent. of ash, but 3 per cent. may be called the average.

Brown coal, or lignite, much of which is found in California, contains from 57 to 70 per cent. of carbon, and represents the first stage of carbonization, being a coal of comparatively recent formation. It is composed of fossil plants more or less mineralized, and when burnt evolves much smoke and affords a dull flame, generally yielding a large quantity of ash. It contains from 2 to 19 per cent. ash.

Caking coal is a bituminous coal, which softens and becomes pasty in the fire, and after the heat has become continued for a time, the volatile ingredients are driven off, and a grayish-black fretted mass is left. The coke obtained from this coal varies from 50 to 85 per cent.

Non-caking coal resembles the above in its external character, but burns freely without softening or showing any appearance of incipient fusion.

Cannel coal is a bituminous coal which generally cakes. It is compact, with little or no luster, and has a dull black or grayish-black color. On distillation it affords, after drying, 40 to 66 per cent. of volatile matter. When held in the flame of a candle it easily ignites, burning with a steady, bright flame. It is used extensively for making illuminating gas, of which it affords a better quality than any other species of coal.

It is well to know that no very extensive apparatus is required to determine many points about coal. It can be examined and its commercial properties determined by the blow-pipe with great accuracy. Mr. Geo. Attwood (eldest son of Melville Attwood, of San Francisco), in his work on "Practical Blowpipe Assaying," gives the following methods of determining the character and properties of coal, by means of the blowpipe:

The assay is divided into five heads.

1st. The moisture determination.

Select from the mass of coal to be examined a few lumps representing as nearly as possible the average quality. Crush them up in the agate mortar into small pieces about the size of a mustard seed.

Weigh out 5 grains, place in a small porcelain dish, and dry at a gentle heat over the spirit lamp. Hard coals sometimes fly when heated, so it is best to cover the dish with a watch-glass while heating. After about 5 minutes, remove the assay and weigh; then repeat the heating and again weigh. As soon as the weights agree the assay is ready to be converted into coke. Plattner states that the percentage of moisture is lowest in anthracite; in bituminous coals it is usually 3 to 4 per cent., seldom 6 to 7, and reaches its maximum in lignite and brown coals, which contain 20 per cent. and sometimes more.

2d. Determination of the coke production.

Take the dried coal and remove to a clay or platinum crucible, and cover with a small roasting clay dish or platinum cup. Place the crucible on a triangle of platinum wire on the blowpipe stand under the flame, using alcohol, and cover it with a small sheet iron funnel (the

same that is used in roasting copper ores). The heat is continued until all the volatile gas has escaped, when the assay generally will appear to possess a fused, porous appearance, and to have a metallic luster.

The coke so made is now removed and weighed. It should be weighed quickly, as coke absorbs moisture from the air rapidly. The coking takes about 10 minutes, and the crucible should not be allowed to get beyond a red heat.

3d. The estimation of the amount of ash.

After the percentage of coke has been determined, remove the assay to a small clay or platinum capsule, and, without using a cover, again heat over the lamp—this time to a bright red color—until all the carbon has been consumed. The operation is much facilitated by occasionally stirring the assay with a piece of platinum wire, also by applying the blowpipe flame to the bottom of the cup when the assay is nearly finished.

If alcohol cannot be obtained, the assay for coke and ash can be conducted in the chareol furnace by using the blowpipe flame, as in the copper assay, and if the ash amounts to more than 5 per cent., the value of the coal is much diminished. If the ash presents a brown, red, or gray color, sesquioxide of iron has been formed by the oxidation of the pyrites in the coal.

4th. Determination of the absolute heating power by Berthier's process.

Take an average sample of the coal and crush it up to the finest powder. Weigh out 0.3 grain of the coal dust and mix it with 12 grains of oxychloride of lead, and after placing the mixture in the crucible cover it with an additional 12 grains of oxychloride of lead.

Oxychloride of lead fuses more readily than litharge; therefore, owing to the large quantity of material which must be brought into a state of fusion in this determination, it is employed instead of litharge.

The assay is next covered with a little powdered glass, also with a few spoonfuls of borax glass. A clay cup is placed over the crucible, and the assay is then fused in the chareol furnace in a similar manner to the silver assay when litharge is used.

About 7 or 8 minutes suffice to melt the assay, and the lead button produced by the carbon in the coal acting on the lead oxychloride will be found lying upon the bottom of the crucible when the assay is cool and the crucible is broken.

The weight of the button, when cleaned from the slag, divided by 20, gives the quantity of lead that one part of the fuel under examination can reduce; and since one part of carbon reduces 34 parts of lead, the heating power of the fuel may be easily ascertained. The amount of lead reduced by one part of coal varies with the different pit coals between 21 and 32 parts, with the lignites between 16 and 25 parts. In making this assay the heat must be applied at first very gradually, and afterward increased to a bright redness.

Dr. Ure's experiments, published in the "Supplement to the Dictionary of Arts, Mines, and Manufactures," have appeared to be unsatisfactory in regard to the accuracy of Berthier's method. Mitchell, however, has found the method correct, and the author has found it equally so. The lead oxychloride should always be pure.

5th. Estimation of sulphur in a sample of coal.

Sulphur generally exists in coal as a sulphide of iron, and as the presence of more than 2 per cent. of sulphur depreciates the market value of coal, owing to its destroying the iron boilers and grates under and over which the coal is consumed, is always an important part of the examination of coal to ascertain the quantity present.

Mitchell, in his "Manual of Practical Assaying," recommends the following process:

Take one part of the finely pulverized coal and mix with 7 to 8 parts of niter, and 16 parts of common salt, and 4 parts of carbonate of potash, all of which must be perfectly pure. The mixture is then placed in a platinum crucible and gently heated at a certain temperature; the whole ignites and burns quietly. The heat is then increased until the mass is fused: the operation is finished when the mass is white. It must, when cold, be dissolved in water, the solution slightly acidulated by means of hydrochloric acid, and chloride of barium added to it as long as a white precipitate forms. This precipitate is sulphate of baryta, which must be collected on a filter, washed, dried, ignited, the filter burnt away, and the remaining sulphate of baryta weighed; every 116 parts of it indicate 16 of sulphur.

The above described methods of examining coal are all that are required for commercial purposes. The assay may be carried on still further by estimating the iron oxide contained in the ash. The ash can also be examined qualitatively for silica, lime, soda and potash.

THE proprietors of the Ilion and Mohawk (N. Y.) Gas Company have commenced work on their proposed electric lighting annex.

ITEMS OF INTEREST FROM VARIOUS LOCALITIES.

THE charter of the Hempstead (L. I.) Gas Light Company has been renewed for 30 years, and a special meeting of the shareholders will be held on the 14th prox., the object of the same being to vote on a proposition to increase the capital stock to \$25,000. It is likely that important plant betterments will be arranged for at Hempstead this season.

Mr. W. H. HAYDEN has resigned the Superintendency of the Fishkill (N. Y.) Gas Company's plant in order to accept the position of Manager and Superintendent of the works at Schenectady, N. Y.

PRESIDENT D. T. ROOTS, of the P. H. & F. M. Roots Company, of Connersville, Ind., writing under date of June 19th, says: "We are glad to report that our exhauster business is beginning to look up. Our business in foundry blowers, rotary pumps, forges, etc., has been very good at all times, but at the beginning of the year our exhauster trade was not what we expected. We now look for a good trade during the rest of the season, as inquiries are very much better than at any time of the year. Below we give some of our recent orders: Wheeling (West Va.) Gas Light Company, one exhauster and engine combined on same bed-plate, with gas and bye-pass valves, pipe fittings, governor, etc., capacity, 1,500,000 cubic feet per day; Florence (Ala.) Gas Company, one exhauster (valves, fittings and arrangement same as at Wheeling), capacity, 300,000 cubic feet per day; Shreveport (La.) Gas and Electric Light Company (same as above) capacity, 160,000 cubic feet per day; Chillicothe (O.) Gas Company, one exhauster (as before), 160,000 cubic feet per day; Galesburg (Ills.) Gas Company, one exhauster and engine combined, capacity, 300,000 cubic feet per day; Portsmouth (O.) Gas Company, one exhauster, capacity, 160,000 cubic feet per day; Brunswick (Ga.) Gas Company, one exhauster and engine combined, capacity, 100,000 cubic feet per day; Macon (Ga.) Gas Light Company, one exhauster, capacity, 675,000 cubic feet per day; Litchfield (Ills.) Gas Company, one exhauster, capacity, 160,000 cubic feet per day; Fort Worth (Texas) Gas Company—order given by Bouton Foundry Company, of Chicago—one exhauster, etc., capacity, 675,000 cubic feet per day." That certainly looks like business.

ON and after July 1st the Providence (R. I.) Gas Company will sell gas at the rate of \$1.30 per 1,000 cubic feet. At least so we have been informed by Treasurer A. B. Slater, who is pretty good authority on such matters.

THE holder tank of the Metropolitan Gas Light Company, of Elizabeth, N. J., was to have been finished last week. The people in interest claim that the backward state of the storage construction is all that prevented them from supplying gas before this date.

MESSRS. J. M. CRITCHLOW, Edwin Fuller and F. W. Perkins, as Liquidating Trustees of the American Gas Improvement Company, through their attorney, Mr. D. F. Patterson, 96 Diamond street, Pittsburgh, Pa., have published the following notice of dissolution: "Notice is hereby given that the American Gas Improvement Company, Limited, a partnership association organized under the Act of Assembly of June 2, 1874, and its supplements, at a regular meeting of its members, at which all its shareholders were present, resolved by unanimous vote to dissolve said association, and elected the undersigned Liquidating Trustees to settle its affairs. All persons indebted to said association will please make immediate payment, and all persons having claims against the same will please present them to the undersigned, who will proceed at once to settle its affairs and distribute its assets under the direction of the Court of Common Pleas, No. 1, of Allegheny county."

THE "Chicago capitalists" in control of a certain fuel gas process, acting in concert with "Asheville (N. C.) capitalists," are said to have organized in Asheville the North Carolina Fuel Gas Company, with a capital of \$50,000. It is said they intend to construct a fuel gas plant at Asheville, which proposition is eminently absurd.

A CORRESPONDENT at Albany, N. Y., writing under date of June 23, says: "I note your reference to the proposed winding up of the affairs of the Troy (N. Y.) Electric Light Company, and forward you the following particulars concerning the same: On the application of Mr. Anthony N. Brady, of Albany, and Chas. E. Davenport, of Troy, a majority of the Trustees of the Troy Electric Light Company, Justice Fursman has granted an order for all persons interested in the corporation to show cause before R. C. Jenness, Referee, at the office of Smith & Parmenter, September 19, why the corporation should not be dissolved.

Parmenter and Smith are attorneys for the petitioner, and the moving affidavits made by Messrs. Brady and Davenport allege that the corporation is insolvent and unable to pay its debts. The assets of the Company are given at \$165,666.67, inclusive of \$32,000 in real estate, \$31,920 in machinery and tools, and \$79,980 in electric dynamos, wires and other apparatus. The liabilities are given at \$346,284.38, and this includes the following indebtedness: Travelers National Bank, New York, \$5,000; Union Bank, Troy, \$21,000; National Bank, \$18,000; Central Bank, \$15,000; D. Powers & Sons, \$18,000; Troy City Bank, \$10,000; National Park Bank, New York, \$20,000; Thomson Houston Electric Company, \$7,500 1st mortgage bonds, \$57,000 2d mortgage, and \$30,000 mortgage on real estate, with \$9,000 interest. The stockholders of the Company and the amount of stock are given as follows: E. Murphy, Jr., \$1,000; E. W. Hydorn, \$4,000; J. Bartlett Hydorn, \$2,000; John E. Healey, \$2,000; A. N. Brady, \$104,200; John B. Powell, \$20,200; G. Robertson, Jr., \$2,000; M. R. Mosher, \$2,600; M. A. Tierney, \$5,000; W. F. Walsh, \$1,500; J. C. Minahan, \$500; J. D. Robinson, \$1,500; Frank B. Abbott, \$2,000; Dennis Maloney, \$5,000; C. E. Davenport, \$1,000. Mr. Brady purchased the stock of Mr. A. E. Powers, President of the Company, and the above order and proceedings were necessary to complete the formal transfer of the property to Messrs. Brady & Davenport, who represent the Troy Gas Company, which succeeds to the property of the Electric Light Company."

A CORRESPONDENT at Evansville, Ind., under date of June 21, writes: "Evidence of the very substantial growth of our city is found in the extension that will shortly be commenced by the Evansville Gas and Electric Light Company. Additional territory has been purchased by the Company in Heidelbach and Elsas' Enlargement, for the extension of its already large electric plant. The business has grown to the full capacity of the works, and the demand upon the resources of the latter is such as to warrant the betterment arranged for. A new building will be erected, the contracts for same having been let to Bedford & Wiechel and Bippus & Kanzler for the brick and carpenter work, respectively. The new structure will cost about \$5,000, and will be constructed on modern lines. A 500-horse power engine will be installed in the new house, and, together with the cost of the electrical apparatus in connection with the plans, an expenditure of \$100,000 will be involved. This electrical station will probably be the largest in the West, with the exception of that at St. Louis. It gives me great gratification to be able to add that ground has also been broken on adjacent property at the gas works for a tank to hold a gasholder with a capacity of 1,000,000 cubic feet. The site of the new holder is just opposite the present plant, on block 113, Lamasco. The cost of this will not fall short of \$50,000. The city has grown fully up to the present capacity of the works, and these extensions are quite in line with the practice of the enterprising men—home capitalists, too—in control of the artificial lighting supply of Evansville."

THE contract for the new stock house (which is to be of iron) of the Isabella Furnace, at Barneston, Pa., has been awarded to the Berlin Iron Bridge Company, of East Berlin, Conn. The Bridge Company's design calls for the construction of an iron house, 54 feet in width by 100 feet in length, so arranged that loaded trains can pass beneath the structure. The Company is figuring on some retort house roof work.

ABOUT a fortnight ago two workmen entered a gas tank at Superior, Wis., that had been unused for 12 years. No attempt at ventilation had been made, and it was by the merest chance that the experimenters were rescued from death by suffocation.

BROTHER JUDGE, of the Rock Island (Ills.) Gas Company, is at his old trick of reducing gas prices, as he informs us, under date of June 18th, that, beginning with June 1st, an additional discount of 25 cents per 1,000 cubic feet will be allowed on all gas consumed at any residence where a gas cooking range is actually in use. This means a net charge in such situations of \$1.50 per 1,000. Good judgment, that.

THE Charlestown (Mass.) Gas Company is making a very extensive series of improvements on its electric lighting plant. The betterments include an additional Armington & Sims engine, and a new boiler house (with an imposing chimney) rated to the satisfactory placing of 1,000-horse power. After a careful trial of different boiler settings the Company has determined to set the new boilers over the well-known Jarvis patent furnace, Mr. Neal being satisfied that the Jarvis plan is much superior to the other types tried at the Charlestown works. It looks somewhat superfluous to add that Treasurer and General Manager Neal, who is known to the gas men of this country as an able and conserva-

tive engineer, still keeps up in the front rank. He was one of the first to advocate the combination of gas and electric interests (we, however, still hold our opinion that locality alone can determine the wisdom of such a step), and the rapidity with which the Charlestown attempt has succeeded speaks for itself. Mr. Neal has been ably assisted in his work by his painstaking Superintendent, Mr. Coyle, who had full charge of the laying out and erection of the new plant. Those who visit Charlestown can count on looking over an excellently appointed and complete electric lighting station.

MR. HENRY D. HILL, of St. Louis, says that the erstwhile popular gasoline stove in that section is fast being replaced by the gas stove, and then adds: "With gas at the present rates it is true economy to use it in preference to gasoline, and with the probable introduction at an early date of fuel gas at 45 cents per 1,000, the use of gas stoves will not be confined to the summer months, but the greater part of domestic cooking will be done on them."

THE proprietors of the Las Vegas (New Mexico) Gas and Coke Company are well satisfied with the progress making on the betterment plans, the adoption of which was noted some time ago in these columns. Supt. Hart is our authority for the statement that the electric annex will be in working order by July 15th.

COL. WAGSTAFF, representing the bondholders of the Bay Shore (L. I.) Gas Company, bid in the property (which was offered at sheriff's sale) for the sum of \$5,000. The liens amount to \$30,000. Mr. John H. Golding will act as Superintendent. This ought to be a good place for a gas company, as Bay Shore is quite a pleasuring ground with a desirable class of summer residents, to say nothing of those who reside there permanently.

A VAGRANT flash of lightning at McKeesport, Pa., the other night caused quite a commotion in that usually placid burgh. Having burned out an electric lighting switch on an arc light at a clothing shop on the corner of Market street and Fifth avenue, nature's current found its way to a gas service that led into the house of Dr. Black. The Doctor was considerably worried over the prospective size of his next gas bill, but his mind is now at ease, as Superintendent Neemes, of the Gas Company, promised to "make it all right" if the Doctor would surrender the section of gas service that had been tapped by the electric visitor.

MISS ELLA KINGSBURY the accomplished daughter of Col. William A. Stedman, and Mr. Marion McAllister Smith were united by marriage at Newport, R. I., on the evening of Wednesday, June 18. The wedding took place in the Channing Memorial Church of that city, and was witnessed by a large assemblage of friends of the contracting parties. After the ceremony a reception was held at the home of the bride's parents, in Mount Vernon street, where a supper was served by Pinard. We extend to the newly-married couple our congratulations upon the happy event, and also our sincere wishes for their future happiness.

DEPOSITIONS are again being taken as a preliminary to the third trial of the case of the United Gas Improvement Company vs. the Manchester (N. H.) Gas Company.

WE are indebted to a St. Louis correspondent for the following, respecting the "strike" at gas capital in Quincy, Ills.—we make bold to say that when the Chicago cormorants succeed in bleeding Steinwedell and Littleton, they will have to come to the attack with sharper beaks than those now so prominently exposed: "A joint stock company has been organized by Chicago capitalists, with an asserted capital of \$400,000, to put up an electric and gas light plant and a fuel gas plant for Quincy. The projectors ask the right to make such use of the city's streets as may be necessary for their purpose. The Company proposes to put its wires either above or below ground, as the city shall direct, and binds itself to furnish lighting gas for the next 5 years at \$1.50 per 1,000 cubic feet. It will furnish fuel gas for the next 5 years at \$1 per 1,000, provided, however, that if at the end of two years the total consumption of lighting and fuel gas amounts to 300,000 cubic feet per day then the price asked shall be \$1.25 per 1,000 for illuminating gas and 90 cents for fuel gas; but, in any event, after 5 years the price of gas shall not be more than \$1.25 and 90 cents for lighting and fuel gas respectively." This is a strike, pure and simple; and it will undoubtedly fail of its purpose.

MISS KREMERS, the accomplished daughter of the Secretary of the Milwaukee Gas Light Company, was united in marriage to Mr. H. A. Salzer on the 26th inst.

COLONEL STEDMAN has two months' leave of absence, and will leave Rochester to-morrow for Tacoma, Wash., from whence he will, on July 8th, sail for Alaska. He expects to be back in Rochester about September 1st, and does not expect to establish gas works in Sitka this trip, but will inspect the icebergs in Glacier Bay with a view, possibly, of utilizing their surfaces to reflect Northern lights over into the State of Washington. We hope the Colonel will have fair skies and balmy days as companions on the trip.

OUR contemporary, the *Berliner*, reports the invention of a soft alloy which adheres so firmly to metallic glass and porcelain surfaces that it can be used as a solder, and which, in fact, is valuable when the articles to be soldered are of such a nature that they cannot bear a very high degree of temperature, the composition consisting of finely pulverized copper dust, which is obtained by shaking a solution of copper sulphate with granulated zinc. The temperature of the solution rises considerably and the metallic copper is precipitated in the form of a brownish powder—20, 30 or 36 parts of this copper dust according to the hardness desired, being placed in a cast iron or porcelain-lined mortar, and well mixed with some sulphuric acid having a specific gravity of 1.85. To this paste thus formed are added 70 parts by weight of mercury, with constant stirring, and when thus thoroughly mixed, the amalgam is well rinsed in warm water, to remove the acid, and then set outside to cool; in 10 or 12 hours it is hard enough to scratch tin. On being used it is heated to a temperature of 375° C. and when kneaded in an iron mortar it becomes as soft as wax. In this ductile state it can be spread on any surface, to which, as it cools and hardens, it adheres with great tenacity.

THE Fort Wayne Electric Company has issued the following circular, under date of June 16th, to its shareholders: "Pursuant to the authority given by the stockholders' vote adopted at the recent annual meeting of this Company, its capital stock has been increased by \$1,000,000, divided into shares of \$25 each. By this increase the Company acquires valuable patents, licenses and contracts, besides \$450,000 in cash for working capital. The Company is thereby enabled to make still more complete and effective its present system of arc and incandescent lighting, and to prosecute its business more extensively and successfully than ever before. Arrangements have been made whereby each stockholder of record at the close of June 20, 1890, will have the right to purchase, within the time specified below, one share of the new stock for every three shares of the old that shall then be standing in his name on the books of the Company, the price at which the stock may be so purchased being \$12.50 per share in cash. The rights of purchase pertaining to the new stock are assignable in writing. Fractional parts of shares cannot be issued either to stockholders of record or to parties acquiring 'rights' by assignment; and purchases of the new stock can be made only on 'rights' presented in lots of three or some multiple thereof. Agreements in writing for the purchase of the new shares will be received at the office of the International Trust Company, No. 45 Milk street, Boston, Mass., until and including Wednesday, June 25, 1890, but not afterwards, and the payments must be made to said Trust Company, in cash, on or before Saturday, June 28, 1890, on which day the stock certificates will be ready for delivery. All agreements to buy, though seasonably made and filed, may be declared void by said Trust Company unless the required cash payment shall be made to it on or before said June 28. By order of the Directors of the Fort Wayne Electric Company its transfer books will be closed from June 21 to June 25, both days inclusive.

IT is reported that a controlling interest in the Edison Illuminating Company's proposed plant at Milwaukee is owned by the Milwaukee Gas Light Company, or by certain of the shareholders in the latter corporation.

A SPECIAL from Yankton, S. Dak., bearing date of June 17th, says that a climax in the contest between the local electric light company and the Gas Company has been reached, in that Judge Smith has granted a temporary injunction restraining the city from contracting with the Gas Company for lighting, on the ground that the city cannot incur further indebtedness than exists. The case, which is attracting much attention in the Northwest, will be heard June 26. It seems likely the electric company will fail to secure a permanent injunction. If it is granted the case will be appealed and carried through to the bitter end.

THE Hon. Joseph H. Hanes has been appointed receiver of the assets of the Cape Island (N. J.) Gas Company.

THE Superior Court (Montreal, Canada) has given judgment for plaintiff (J. S. Brown) in the sum of \$631 in his damage suit against the

Montreal Gas Company. Although we gave the main details of the case (in our notice of the filing of the suit) some weeks ago, we herewith reproduce a summary of the same. The suit was for damages owing to the illness of plaintiff's wife from an escape of gas into their dwelling house, No. 13 Bishop street. Judge Gill held that the Gas Company was liable for all the costs Mr. Brown was put to in connection with Mrs. Brown's illness, and for the general discomfort occasioned in his household, especially as the Company was frequently notified to repair the leak from which the gas escaped in the Bishop street main. The Gas Company have a suit in warrant against the city, which they accuse of having done the damage by breaking the main with the heavy street roller.

A CORRESPONDENT at Wheeling, W. Va., says the Board of Trustees of the City Gas Works are bending all their energies at present in the direction of putting the works in first-class condition, and also increasing their capacity. To this latter end 4 new benches of 6 retorts each are being put in, and 12 benches of 6's are being thoroughly overhauled. The gasmaking machinery is also being overhauled, and repairs made to the big \$40,000 holder, which has been leaking for some time back. As far as they are able, the Trustees will put in duplicate machinery at the works, to avoid jeopardizing the gas supply in the contingency of a break-down.

ASSOCIATED PRESS despatches, dated Trenton, N. J., June 24, are to the following effect: "The American Gas Investment Company filed a certificate of incorporation here to-day. The capital stock is \$50,200,000, but only \$10,000 is paid in. The stockholders named are: Geo. S. Bixby and Hector W. Thorne, of New York, and Wm. Talcott, of Paterson. The objects of the Company, as set forth in the charter, are to construct, acquire, own, manage and operate works for the manufacture, distribution and supply of light, heat and power by gas, electricity or otherwise, and generally to carry on any business incidental thereto, and to acquire the stocks and securities of other corporations formed for any similar purpose, and to deal in the same. The charter is worded like that of a trust, and it is believed here to be a reorganization of the Chicago Gas Trust, although it is also stated that it is a venture of English capitalists. The fee for the filing of the charter is \$10,040, the largest the State has ever received.

THE Committee on Public Buildings, Salem, N. J., advertised for bids for lighting the Mayor's office and jail, for the term of 1 year, and in response thereto received tenders from the Salem Gas Light Company and the local Electric Light Company. The former offered to do the work for the sum of \$140, while the electricians asked \$160. The Salem Gas Company secured the award.

THE London *Journal* notes that the *Electrical Review* asks when we are to have a really reliable electric meter, which will be direct-reading, will not increase its records unduly as more current is passed through it, and will be fair alike to user and supplier. There is at present, we are informed, a meter in use which reads direct; but as fresh lamps are added to the circuit in which it is placed, it records an excess of current. Another gives indications which have to be multiplied by a constant, which is, of course, a decimal quantity, and therefore an unknown tool in the hands of the average householder. A third meter is a box of mystery, of the nature of which the consumer is in absolute ignorance, not unmixed with fear. He is told by the official of the electric lighting company who supply the instrument that so many hours' use of the current in the house will be recorded by an increase of weight in a plate inclosed in the box; and he is entirely at the mercy of the company. Consequently, it is no wonder that disputes arise. We know how it is with gas meters and consumers; and the gas meter is not only a positive measurer, while most, if not all, electricity meters are inferential, but it is also cheap and reliable in a degree that arouses the envy and despair of electricians.

THE Fidelity Trust Company, of Philadelphia, has been ordered to pay all money in its possession belonging to the Chicago Gas Company over to Receiver Davies. The latter will on receipt of the cash pay to shareholders the dividend recently declared.

MR. THOMAS E. LILLY, of St. Louis, Mo., has designed a sign to take the place of those formerly displayed on the gas street lamps for identifying the names of streets at crossings. It is a label triangular in form, and made to fit on the top of a post, to which it is fastened by a set screw. The lettering is white on a black ground, occupies two sides of the triangle, and is very distinct. The cardinal letters of the compass are also properly placed. The sign can be fitted to the electric light or telegraph poles.

SUPERINTENDENT WANTED

For a small but nearly new and fairly well built and arranged Gas Works. Qualities required are, first, that the interests of the owners and superintendent shall be identical; second, ability and willingness to work; third, tact to deal with consumers in such a way as to hold trade in spite of opposition. Temperance a pre-requisite. Supt. engaged will have entire charge of plant, including books, with no interference except an occasional consultation with the undersigned. Salary, \$1,200. Address 785-2 C. E. BURROWS, Walla Walla, Washington.

Position Wanted

As Superintendent or Assistant in a Gas Works,

By a man who can give the best of references. Thoroughly understands the manufacture and distribution of gas and the construction of works. Address "D. D.," care this Journal. 785-2

SITUATION WANTED

As Superintendent of a Gas Works,

By a man of 20 years' experience. Best of references. Address JOHN COLLINS, 324 Clinton Street, Schenectady, N. Y. 783-tf

WANTED, A Six-Inch Exhauster.

SECOND-HAND. Must be in good condition. Roots' make preferred. Address POUGHKEEPSIE GAS CO., Poughkeepsie, N. Y. 783-

FOR SALE,

- One 12-Inch Air Condenser.
- One Multitubular Condenser.
- One Anderson Washer.
- Six 12-Inch Chapman Valves.

For particulars apply to NEW HAVEN (CONN.) GAS CO.

FOR SALE,

The Ironwork for Ten Benches of Fives (5's).

Cast iron Hydraulic Main, 16 by 18 in. Stand Pipes, 5 in. at bottom, 4 in. at top. Bridge and Dip Pipes, 4 in. Address DAYTON GAS LIGHT AND COKE CO., 120 East Third Street, Dayton, Ohio. 783-tf

Engines and Boilers For Sale

- Five 80-H.P. Ft. W. Bass Automatic Cut-Off Engines, 12 by 16 in.
- Three 40-H.P. Armington & Sims Automatic Cut-Off Engines, 9 by 12 in.
- One 50-H.P. New York Safety Automatic Cut-Off Engine, 10 by 12 in.
- Four Tubular Boilers, Steel, 16 ft. by 60 in., forty-four 4 in. flues. Full front.
- Two Tubular Boilers, Steel, 16 ft. by 60 in., eighty 3-in. flues. Full front.
- One No. 5 Dean Pump.
- Three Sets J. H. Turner Patent Heaters.

The above are in good condition and in operation. Write for particulars.

JENNEY ELECTRIC LIGHT AND POWER CO., Peoria, Ills. 783-tf

FOR SALE.

GAS LIGHT PLANT,

In a growing town of 5,000 inhabitants. Oil Gas Process. For particulars address LATROBE GAS COMPANY, 784-6 Latrobe, Pa.

FOR SALE.

One 5-ft. Station Meter,

8-inch Connections.

In good order. Price, \$300, L.o.b. at Poughkeepsie, N. Y. POUGHKEEPSIE GAS CO., Poughkeepsie, N. Y. 783-tf

WANTED TO LEASE

A Small Gas Works,

By a practical gas man. Address "W. E. F." care this Journal. 784-8

The New York Oxygen Co.,

No. 80 Broadway,

Are prepared to give full information on the application of Oxygen to the purification of lighting gas.

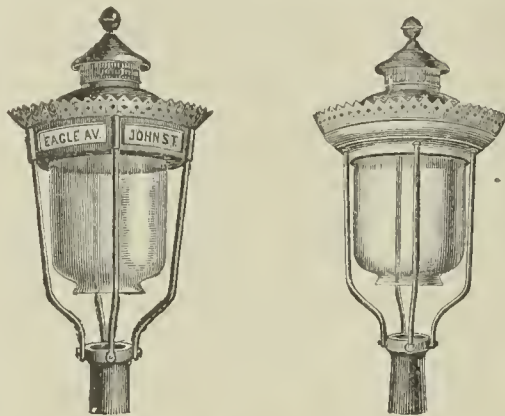

The Miner Street Lamps.

Jacob G. Miner,

No. 823 Eagle Ave., New York, N. Y.

Simpkin & Hillyer

RICHMOND, VA.

MANUFACTURERS OF

Gas Works Apparatus

BENCH CASTINGS, CONDENSERS, Scrubbers, Purifiers, Dry Center Seals, FOUR-WAY VALVES, GAS VALVES, SULPHATE OF AMMONIA APPARATUS, TANKS, ENGINES, BOILERS, PUMPS, ETC., ETC.

Plans, Specifications and Estimates furnished for new works, or alteration of old works. Correspondence solicited. Works, Newport News, Va.

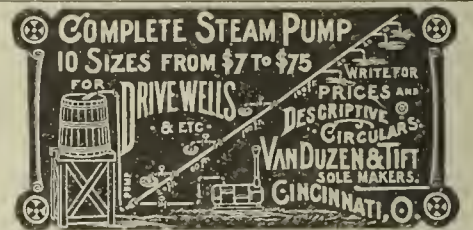

Bartlett Street Lamp Mfg. Co.

MANUFACTURERS OF

Globe Lamps,

FOR Streets, Parks, Public Buildings, Railroad Stations, etc.

LAMP POSTS

A Specialty.

Office and Salesroom, 40 & 42 COLLEGE PLACE, - - N. Y. CITY.

Gas Companies and others intending to erect Lamps and Posts will do well to communicate with us.

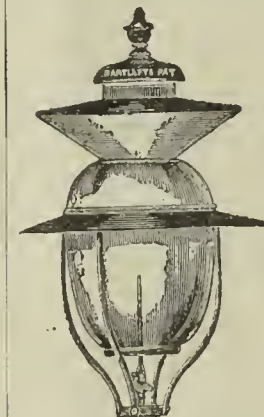

GASHOLDER PAINT.

Use Only

THE GOVERNMENT WATERPROOF PAINT.

Proof against Ammonia, and Absolutely Waterproof. Send for Prices and Particulars.

THE GOVERNMENT WATERPROOF PAINT CO., 122 Milk Street, Boston, Mass.

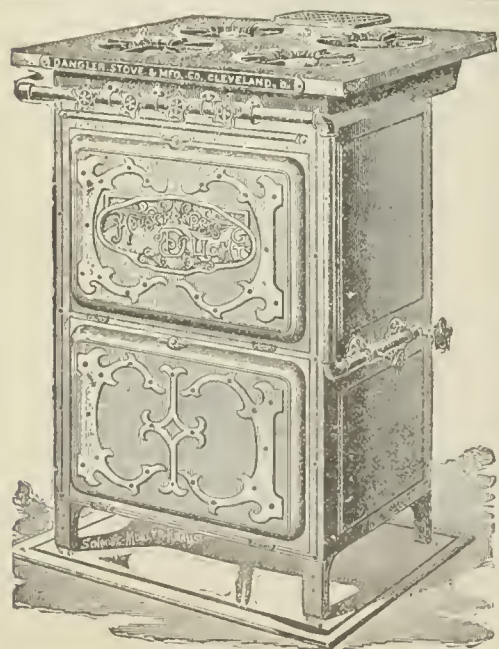

The Hot Water Problem Solved.

The most serious drawback to the general introduction and use of Gas for domestic purposes has been the supply of hot water. The only way of heating water heretofore has been by a separate attachment, which is both inconvenient and adds materially to the expense.

We are pleased to say to those interested that after many experiments we have been entirely successful in making a Gas Range with an ATTACHMENT FOR HEATING WATER AS A PART OF THE RANGE, direct from the burners, while the Range is being used for cooking and general domestic work, in the same manner as water is heated by the ordinary coal or wood range. A large number of these Ranges are now in DAILY USE, GIVING PERFECT SATISFACTION, not only for supplying hot water, but in all other respects. Our price and discounts to the trade are liberal and satisfactory. For further information address

THE DANGLER STOVE AND MFG. COMPANY, Cleveland, Ohio.

FORT WAYNE ELECTRIC CO.

FORT WAYNE, IND.

MANUFACTURERS OF THE

Slattery Induction System

—OF—

LONG DISTANCE INCANDESCENT LIGHTING.

The Most Carefully Worked Out and Complete Alternating Current System of Electric Lighting in Existence.

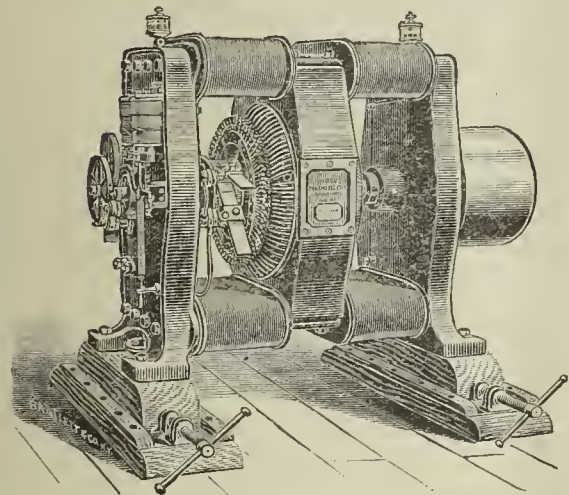

Wood Dynamo.

— AND THE —

WOOD

Automatically Regulating
ARC DYNAMOS and LAMPS.

Main Office, - - - Fort Wayne, Indiana.

Factories: Fort Wayne, Ind.; Brooklyn, N. Y.

BRANCH OFFICES.

NEW YORK, - - - - -	115 Broadway.
PHILADELPHIA, - - - - -	907 Filbert Street.
CHICAGO, - - - - -	185 Dearborn Street.
SAN FRANCISCO, - - - - -	35 New Montgomery Street.

DETROIT, MICH., - - - - -	57 Gratiot Avenue.
TORONTO, CANADA, - - - - -	138 King Street, West.
MEXICO, F. Adams' Successors, - - - - -	City of Mexico.
CUBA, Maicas & Co., - - - - -	Havana

LACLEDE FIRE BRICK MANUFACTURING COMPANY,

ST. LOUIS, MO.

Exclusive Agents in the United States

FOR THE

Coze System of Inclined Retorts.

IT IS THE COMING BENCH
FOR MAKING COAL GAS.

*It will Save from 50 to
60 per ct. in Labor.*

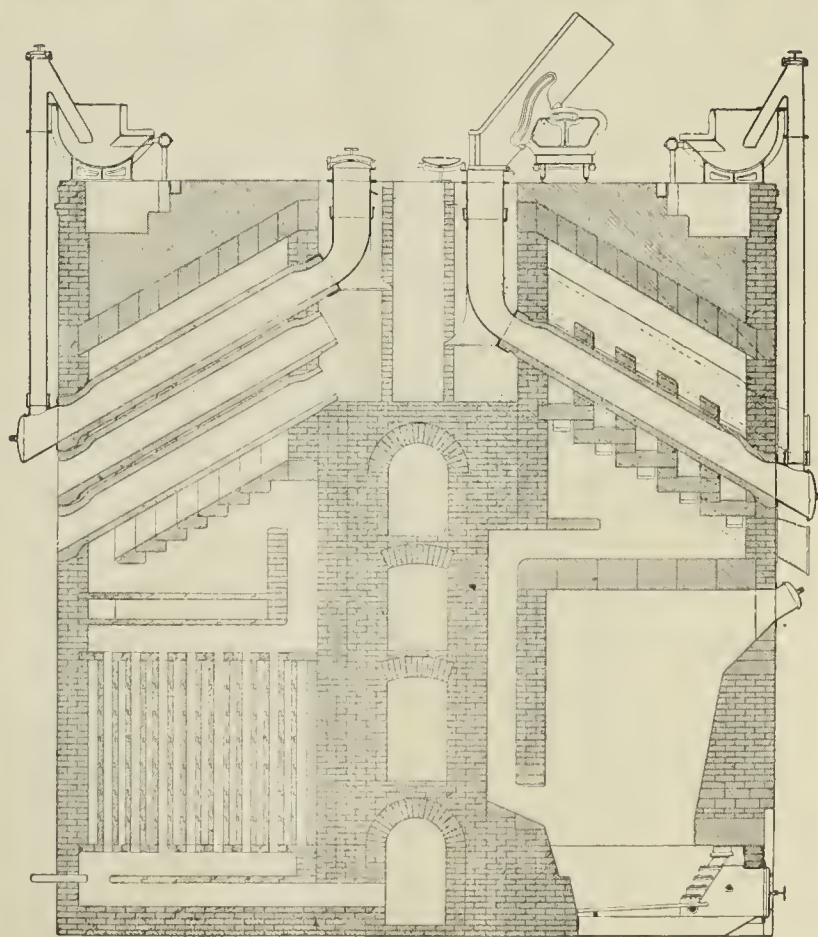
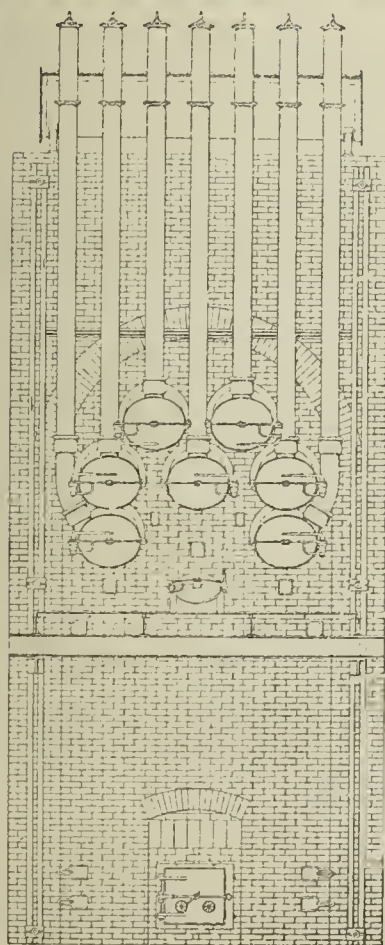

ESTIMATES AND PLANS FURNISHED BY THE

LACLEDE FIRE BRICK MFG. CO., ST. LOUIS, MO.

The Gordon Portico Lamp.

A successful Competitor of the Arc Electric Light for lighting Store Fronts, Show Windows, Depots, Railway Sheds, etc., etc.

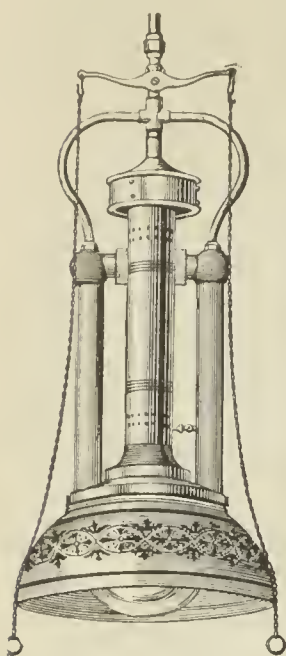

Gordon Portico Lamp.

The Gordon Street Lamp.

A Successful Competitor of the Arc Electric Light for lighting Streets, etc., etc.

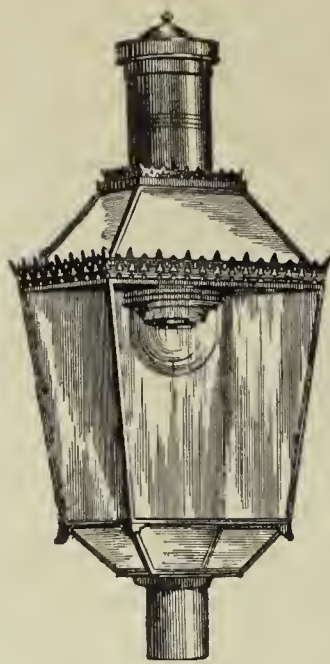

Gordon Street Lamp.

The Lungren Lamp.

A Successful Competitor of the Incandescent Electric Light for Interiors, etc. Is especially applicable for the lighting of Offices, Stores, Factories, Mills, Show Windows, Libraries, and all situations where an increased illumination is desired.

More than 25,000 Lungren Lamps are now in use. Testimonials, references, or any desired information will be cheerfully given.

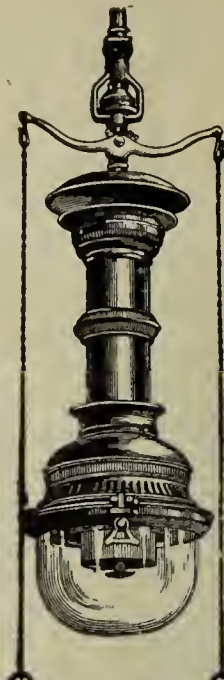

Lungren Lamp.

THE SIEMENS-LUNGREN CO., N.E. Cor. 21st St. & Washington Av., PHILADELPHIA.

WELSBACH SYSTEM OF Incandescent Gas Lighting.

OFFICE, DREXEL BUILDING, PHILA., PA.

At the Fall Session of the Board of Supervisors of Winnebago County, held at the County Court House, Oshkosh, Wis., Nov. 26, 1889, the report submitted by Mr. C. W. Cook, Chairman of the Committee on Public Buildings, recommending the use of the Welsbach Incandescent Gas Burner in the Buildings under their charge, was unanimously adopted, because of the extreme economy in the consumption of Gas and the superior character of the light obtained.

MOSES G. WILDER, MECH. ENGR.
816-18-20-22 Cherry St., Phila., Pa.

Volumetric Lamp Governors

FOR GAS LAMPS & HIGH-POWER BURNERS.

Governor Burners for Street Lamps & General Use

GOVERNORS FOR ARGAND AND OTHER COMMON GAS BURNERS IN ALL SIZES.

Horizontal Governors

Specially Adapted for Gas Stoves, Furnaces, etc.



It is well known that a large majority of all High Power Gas Lamps in the United States have my Governors attached, and they are always used by the leading makers of these lamps. To remove any excuse for the use by anyone of inferior and infringing Governors, a reduction in price has been made, and all exclusive contracts are cancelled.

Correspondence Solicited with all who require a Reliable Governor.

FRIEDRICH LUX,

Ludwigshafen am Rhein and London.

Lux Mass

GAS GOVERNORS,

Gas Balance.



EDGEWATER LIME WORKS

Chas. F. McKenna, Proprietor.

SHELL LIME.

Lime by the Cargo for Gas Purification.

EDGEWATER, BERGEN CO., N. J.

Write for Testimonials and Prices.

CHICAGO GAS STOVE CO.

MANUFACTURERS OF ALL KINDS OF

Gas Cooking and Heating APPLIANCES.

117-119 Lake St., CHICAGO.

Send for Catalogue.

JEWEL GAS STOVES

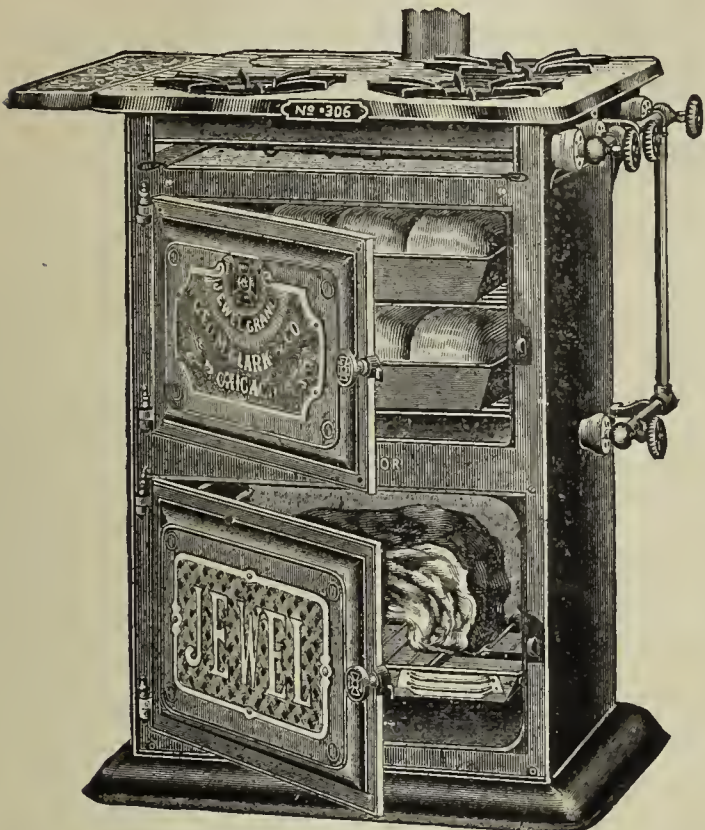

Are Best,

BECAUSE THEY ARE

HIGH GRADE,

Interchangeable,

RIGHT!

WE USE NO GAS COCKS.

All Flames are Regulated by Direct Needle Valves.

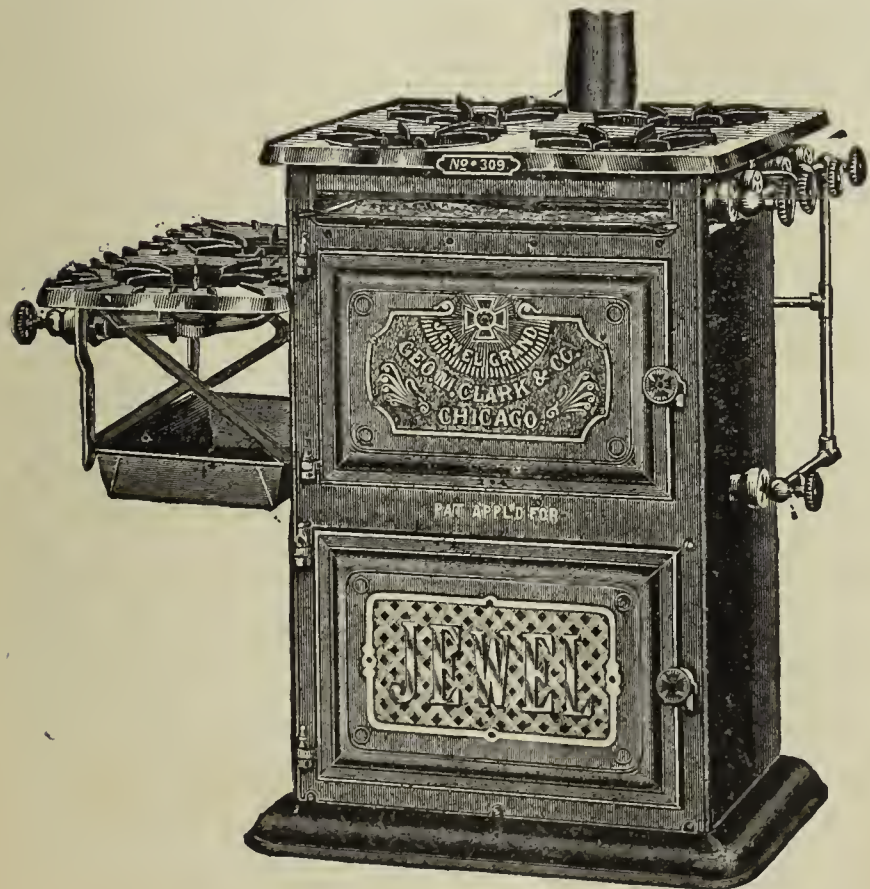

JEWEL CIRCULATING WATER HEATER.

No. 510, - - - - \$15.00.

Write for Jewel 1890
Catalog.

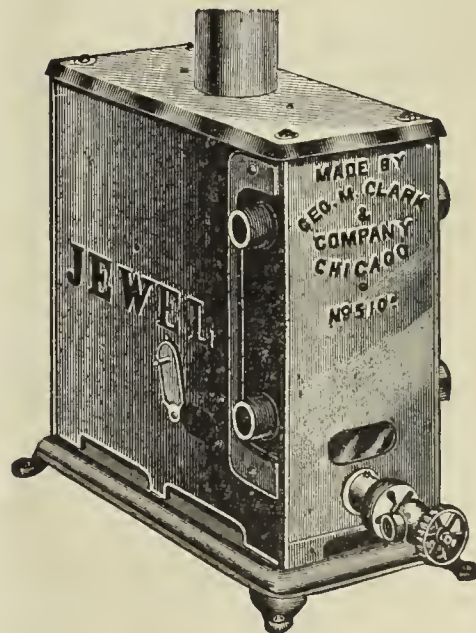

GEORGE M. CLARK & COMPANY,

MANUFACTURERS,

157 & 159 Superior Street, - - - Chicago, Ill.

NATIONAL GAS LIGHT AND FUEL CO.,

218 La Salle Street, Chicago.

C. D. HAUKE, Prest. & Gen'l Manager.

A. W. GREEN, Vice-Prest.

N. A. McCLARY, Sec. & Treas.

E. E. MORRELL, Engr.

GAS WORKS

Built, Remodeled, Leased, and Purchased.

71 Springer Cupolas have been installed in the U. S. during the past four years.

The total capacity of Springer Apparatus now in use is over 25,000,000 ft. daily.

THE SPRINGER CUPOLA SYSTEM

Has Proven Itself the most Economical and Satisfactory Method of Gas Manufacture ever brought to the attention of the Gas Fraternity.

GUARANTEED ESTIMATES of Cost of Gas Furnished on Application.

GASHOLDER TANK CONSTRUCTION, ETC.

Gas Companies and others about to erect Gasholders will find it profitable to consult W. C. Whyte, who for over 30 years has made a specialty of

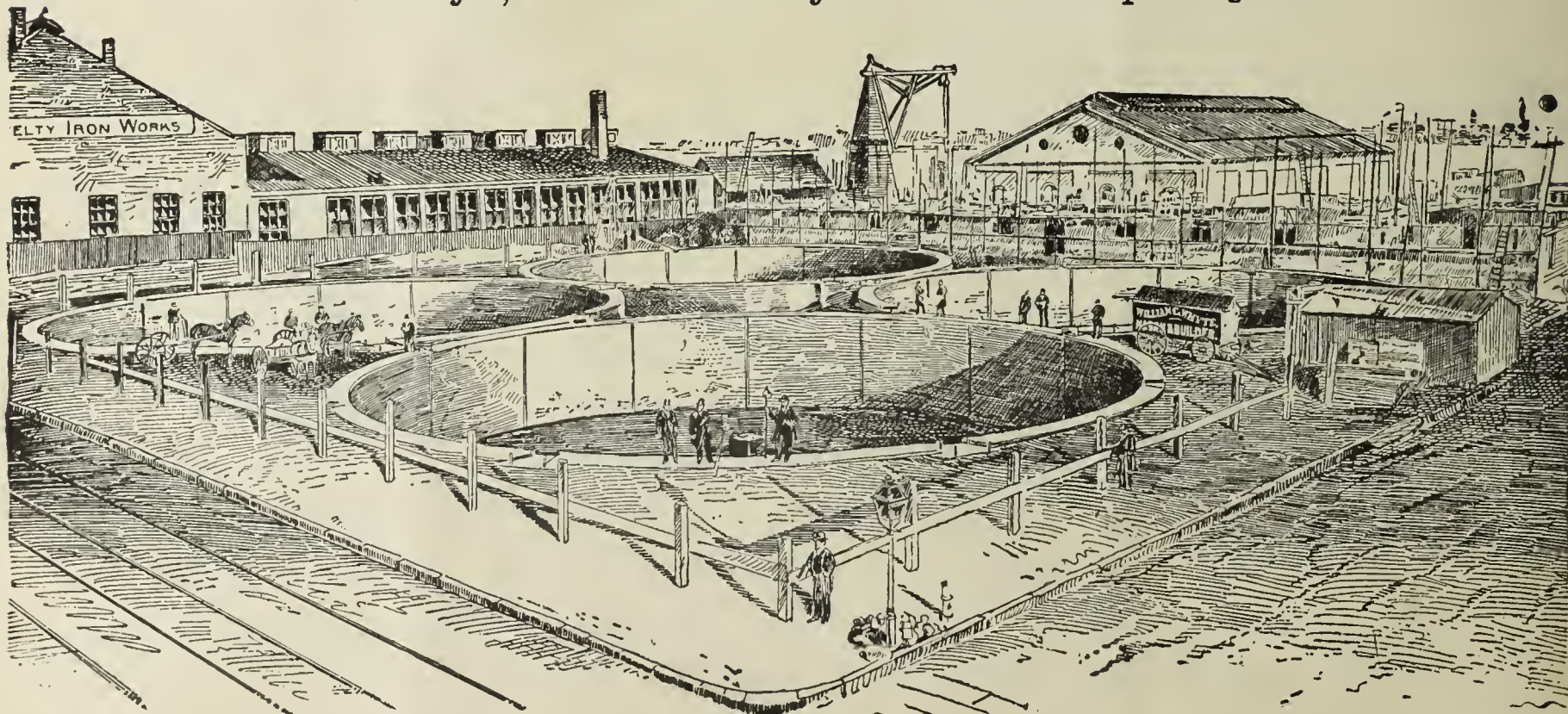

Tank Excavation and Mason Work.

Fifty Tanks now in operation show the sort of work done. Address

W. C. WHYTE. - No. 15 Cortlandt Street, N. Y. City.

GAS STOVES.

GAS METERS.

GAS STOVES.

THE AMERICAN METER CO.

Established 1834.

Incorporated 1863.

MANUFACTURERS OF

Gas Meters,

STATION METERS,

METER PROVERS, PHOTOMETERS,

Pressure Gauges of all Kinds,

AND



Standard 3 Diaphragm Dry Meter.



Standard 2 Diaphragm Dry Meter.

Apparatus for Testing the Quantity and Quality of Gases.

GAS STOVES FOR HEATING AND COOKING.

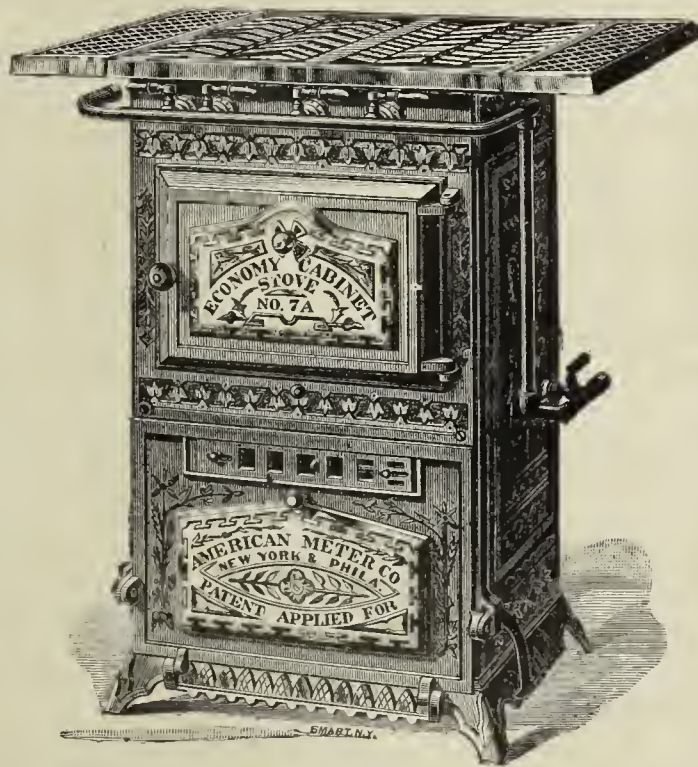

Circulars and Price Lists on Application.

MANUFACTORIES,

508 to 514 West Twenty-second St, N. Y. Arch and Twenty-second St., Phila.

Nos. 244 & 246 North Wells Street, Chicago, Ill.

AGENCIES,

No. 177 Elm Street, Cincinnati, Ohio. No. 222 Sutter Street, San Francisco, Cal.

No. 810 North Second Street, St. Louis, Mo.

GAS STOVE SHOW ROOMS, No. 242 Sixth Avenue, New York City.

KIRKHAM, HULETT & CHANDLER, LIMITED.

PATENT "STANDARD" WASHER-SCRUBBERS
Erected and in course of construction at present date:

Capacity. Cubic feet per day.		Capacity. Cubic feet per day.		Capacity. Cubic feet per day.		Capacity. Cubic feet per day.	
Altrincham.....	600,000	Dublin.....	3,000,000	LONDON—Continued.		Ober Schlesian.....	1,500,000
Adelaide.....	600,000	Dowlais.....	100,000	Shoreditch.....	2,500,000	Otto & Co.'s Coke Works.....	1,500,000
Aldershot.....	200,000	Douai.....	500,000	Pancras.....	1,500,000	Plymouth.....	2,000,000
Allegheny, U. S. A.....	1,000,000	Denton.....	500,000	".....	1,500,000	Parramatta, N. S. W.....	100,000
Ashton-under-Lyne.....	1,250,000	Derby, U.S.A.	350,000	Pimlico.....	2,000,000	Prescott.....	150,000
Amsterdam.....	1,500,000	Denver, "	500,000	Nine Elms.....	3,000,000	Providence, U.S.A.	750,000
".....	1,500,000	".....	1,000,000	".....	3,000,000	".....	750,000
Annaberg.....	200,000	Dusseldorf.....	750,000	South Metropolitan Co:—		Plauen.....	300,000
Arcachou.....	100,000	".....	500,000	Greenwich.....	3,000,000	".....	300,000
Animal Charcoal Co.....	200,000	Dunfries.....	250,000	Woolwich.....	400,000	Portsmouth.....	2,500,000
Altoona, U.S.A.....	350,000	Dunedin, N.Z.....	400,000	Vauxhall.....	3,000,000	".....	2,500,000
Buxton.....	250,000	Darlington.....	1,250,000	".....	3,000,000	Pittsburgh, U.S.A.	1,500,000
Bradford.....	1,000,000	Detroit, U.S.A.	750,000	Lea Bridge.....	300,000	Portland, "	560,000
".....	1,250,000	Edinburgh.....	1,500,000	West Ham.....	1,500,000	Pawtucket, "	500,000
".....	1,250,000	".....	2,000,000	Leeds.....	2,000,000	Quebec	250,000
".....	1,250,000	Enfield.....	300,000	".....	3,000,000	Radelife.....	750,000
".....	1,000,000	Essex.....	300,000	".....	3,000,000	Rouen.....	250,000
".....	1,000,000	Falmouth.....	150,000	".....	3,000,000	Ramsgate.....	1,000,000
".....	1,000,000	Frankfort.....	300,000	".....	3,000,000	Reigate.....	200,000
".....	3,000,000	Farnworth.....	400,000	".....	3,000,000	Richmond, U.S.A.	250,000
Bremen.....	150,000	Fenton.....	400,000	".....	3,000,000	Roxbury, "	500,000
Baltimore, U.S.A.	1,000,000	Friedenshutte.....	500,000	".....	2,000,000	Runcorn Soap Co.....	20,000
".....	1,000,000	Furth.....	400,000	Leominster.....	150,000	Rockhampton, N. S. W.....	125,000
".....	1,000,000	Freiburg.....	200,000	Leiden.....	500,000	Richmond.....	1,500,000
Calmaiu, N.S.W.....	125,000	Goole.....	250,000	".....	600,000	Reading.....	2,000,000
Bishops Stortford.....	150,000	Glossop.....	300,000	Liverpool.....	2,000,000	Reichenbach.....	200,000
Blackpool.....	400,000	Guildford.....	300,000	".....	2,000,000	Salford.....	1,750,000
Brussels.....	1,250,000	Gloucester.....	1,250,000	".....	2,000,000	".....	1,750,000
".....	1,250,000	Gera.....	300,000	".....	2,000,000	Smethwick.....	750,000
".....	750,000	Grafton, N.S.W.....	100,000	".....	2,000,000	Sydney, N. S. W.....	1,000,000
".....	1,250,000	Grieg.....	300,000	".....	3,000,000	".....	1,000,000
Banbury.....	250,000	Georgetown, U.S.A.	250,000	Lincoln.....	1,000,000	".....	2,500,000
Birmingham.....	5,000,000	Gleekauf.....	200,000	".....	600,000	".....	50,000
Birkenhead.....	2,500,000	Heywood.....	600,000	Lowell, U. S. A.	1,000,000	".....	50,000
Blackburn.....	1,500,000	Holywood.....	125,000	Louisville "	1,500,000	Sunderland.....	1,500,000
Bochum.....	600,000	Huy.....	70,000	Long Eaton.....	500,000	St. Josephs, U.S.A.	250,000
Burntisland.....	250,000	Harrow.....	250,000	Lilie.....	900,000	Spa.....	100,000
Boston, U.S.A.	2,000,000	Harrogate.....	250,000	".....	450,000	Sevenoaks.....	300,000
Brisbane.....	1,500,000	Halstead.....	150,000	".....	750,000	St. Petersburg.....	2,000,000
".....	300,000	Heilbronn.....	200,000	".....	250,000	".....	1,500,000
Burton-on-Trent.....	1,500,000	Havana, Cuba.	750,000	".....	250,000	St. Louis, U.S.A.	2,000,000
Barcelona.....	350,000	Hastings.....	1,500,000	Lukenwalde.....	330,000	".....	2,000,000
Barking.....	100,000	Huddersfield.....	300,000	Liegwitz.....	300,000	Laclede.....	1,000,000
Baelien & Co.....	20,000	".....	750,000	Lincoln, U. S. A.	250,000	Silesian Coal Co.....	600,000
".....	20,000	".....	1,500,000	Lawrence "	500,000	San Francisco, U.S.A.	2,000,000
Bombay.....	400,000	Hof.....	200,000	Lynn "	300,000	".....	2,000,000
Buffalo, U.S.A., Mutual.	750,000	Hampton Wick.....	500,000	Lyons.....	1,500,000	Sheepbridge Coal Co.....	40,000
".....	500,000	Heckmondwicke.....	500,000	Maidstone.....	1,000,000	Stettin.....	200,000
".....	500,000	Heckmondwicke.....	500,000	Marseilles.....	1,500,000	Singapore.....	300,000
Berlin.....	1,250,000	Haverfordwest.....	100,000	".....	1,500,000	Sutton.....	500,000
Bourneouth.....	1,000,000	Halifax, N.S.	350,000	Mons.....	500,000	Tonbridge.....	150,000
Bridgeport, U.S.A.	500,000	Hamm.....	200,000	Malines.....	250,000	Tipton.....	400,000
Brunswick.....	300,000	Halle.....	400,000	Melbourne.....	1,500,000	Tottenham.....	1,000,000
Beck & Co., St. Louis.	100,000	Heidelberg.....	300,000	".....	1,500,000	Toledo, U.S.A.	750,000
Barmen Rittershausen.....	600,000	Hartford, U.S.A.	1,000,000	".....	1,500,000	Toronto	1,000,000
Bexhill.....	125,000	Ilkeston.....	300,000	".....	1,500,000	Uxbridge.....	300,000
Brooklyn, U.S.A.	1,000,000	Inverness.....	250,000	".....	1,500,000	Valparaiso	500,000
".....	1,000,000	Ilkley.....	200,000	Manchester.....	2,500,000	West Bromwich.....	1,000,000
".....	1,000,000	Ilford.....	100,000	Middleton.....	400,000	Willenhall.....	250,000
Brunner, Mond & Co.....	400,000	Kingston-on-Hull.....	400,000	Manley, N. S. W.....	100,000	Weston-super-Mare.....	500,000
Cheltenham.....	2,000,000	Kidderminster.....	750,000	Minneapolis, U. S. A.	750,000	Waltham.....	150,000
Cannes.....	200,000	Kidsgrove.....	100,000	Magdeburg.....	300,000	Wormwood Scrubs.....	300,000
Croydon.....	1,500,000	Konigberg.....	1,000,000	Memphis, U. S. A.	750,000	Williamsburg, U.S.A.	600,000
Copenhagen.....	200,000	Kiug's Lynn.....	300,000	Nottingham.....	1,250,000	".....	600,000
Clevedon.....	200,000	LONDON:—		".....	2,500,000	Wellington.....	150,000
Columbus, U.S.A.	500,000	The Gaslight and Coke Co.:		".....	2,500,000	Warwick.....	300,000
Cincinnati, "	1,500,000	Beckton.....	1,250,000	".....	2,000,000	Wheeling, U.S.A.	500,000
".....	1,500,000	".....	1,250,000	".....	1,500,000	Walker.....	300,000
".....	1,500,000	".....	1,250,000	Newport, U.S.A.	430,000	Westgate.....	100,000
Chicago	3,000,000	".....	1,250,000	Newmarket.....	150,000	Wilmington, U.S.A.	500,000
".....	1,000,000	".....	1,250,000	Newark, U.S.A.	680,000	Windsor, N. S. W.....	100,000
".....	1,000,000	".....	1,250,000	Northfleet.....	200,000	Wolverton.....	100,000
Chemnitz.....	1,000,000	".....	2,500,000	New York, U.S.A.	2,000,000	Wellington, N. Z.....	250,000
Crewe.....	1,250,000	".....	2,500,000	Nice.....	600,000	Whitchurch.....	175,000
Colonial Gas Works Co.....	100,000	Silvertown.....	1,000,000	Newcastle, N. S. W.....	200,000	Washington, U.S.A.	2,000,000
Cadiz.....	300,000	Bromley.....	2,000,000	Numea, ".....	100,000	Wallasey.....	750,000
Charlottenburg.....	600,000	".....	1,500,000	Namur.....	250,000	Weimar.....	150,000
Dudley.....	750,000	".....	1,500,000	Newark.....	350,000	Wurzen.....	200,000
Driffield.....	100,000	".....	1,500,000	Oldbury.....	500,000	Worcester, U.S.A.	750,000
Dukenfield.....	500,000	".....	2,000,000	Otley.....	200,000	Yeovil.....	500,000
Dover.....	750,000	".....	1,500,000	Oswestry.....	250,000		
".....	1,000,000						
Deal.....	200,000						
Derby.....	1,500,000						

SOLE AGENT FOR WESTERN HEMISPHERE,

GEO. SHEPARD PAGE, 69 WALL STREET, NEW YORK

THE UNITED GAS IMPROVEMENT CO.,

DREXEL BUILDING, PHILA., PA.

Owners of the Lowe, Granger-Collins, McKay-Critchlow (for carbureting Natural Gas), and Other Gas Patents.

BUILDERS, LESSORS *and* PURCHASERS OF GAS WORKS.

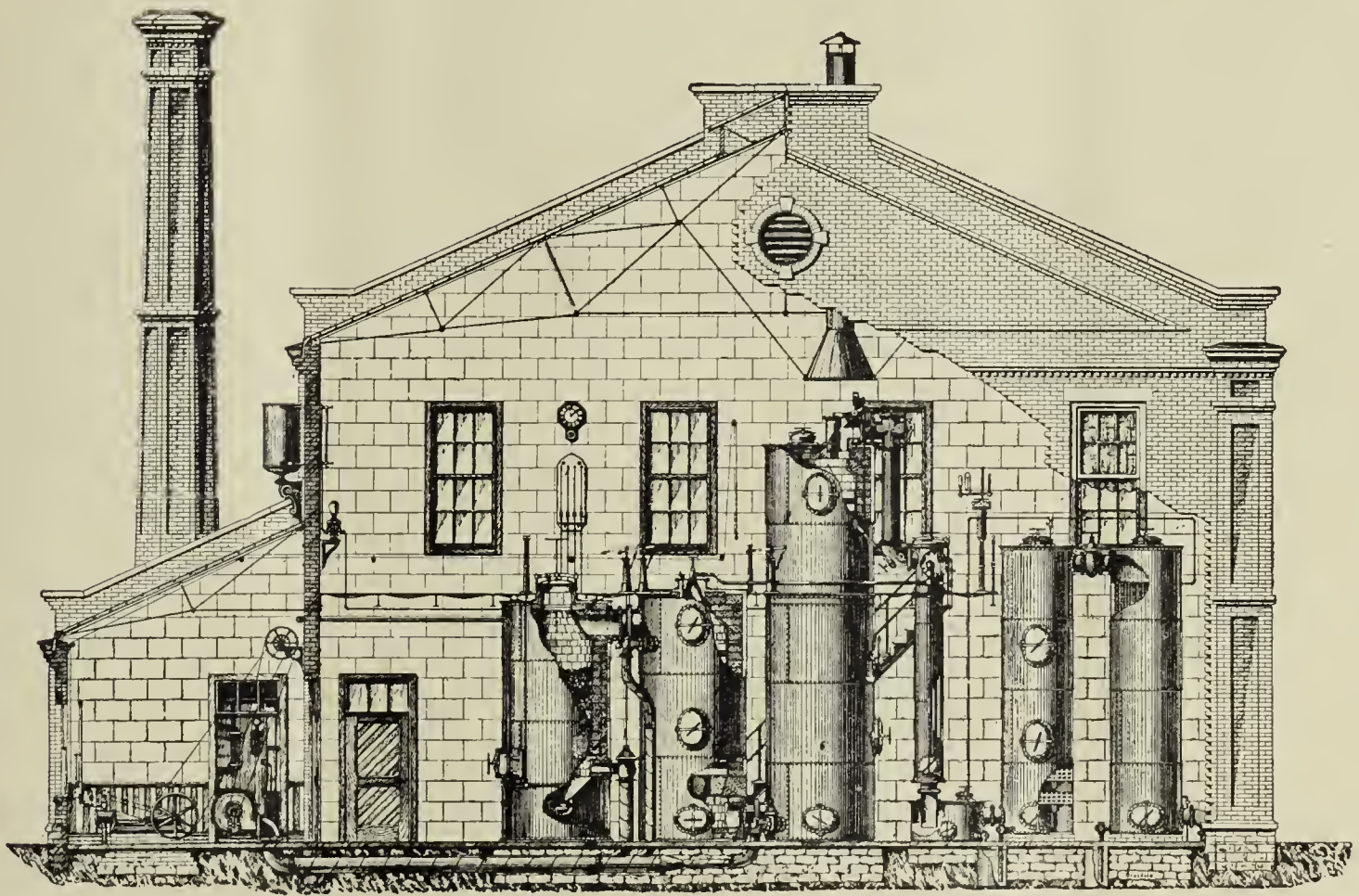

Standard "Double Superheater" Lowe Apparatus, Especially Designed for the Use of Lima Crude Oil.

Erectors of

WATER GAS PLANTS,

(Either Independent or Auxiliary to Coal Gas Works),

USING LIMA OR OTHER LOW GRADE OILS AND ANTHRACITE COAL OR GAS HOUSE OR OVEN COKE.

ROOTS' GAS AND BYE-PASS VALVES.

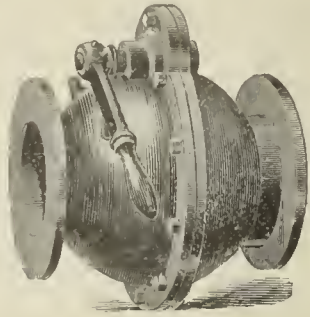

GAS VALVE

Quick Acting,
Simple,
Efficient, Durable.

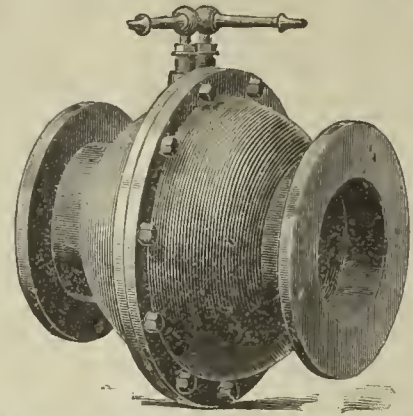

BYE-PASS VALVE.

Automatic Action
Reliable
Simple Durable.

Thousands now in use and giving perfect satisfaction. Write for Catalogue and Prices.

ROOTS' NEW GAS EXHAUSTER.

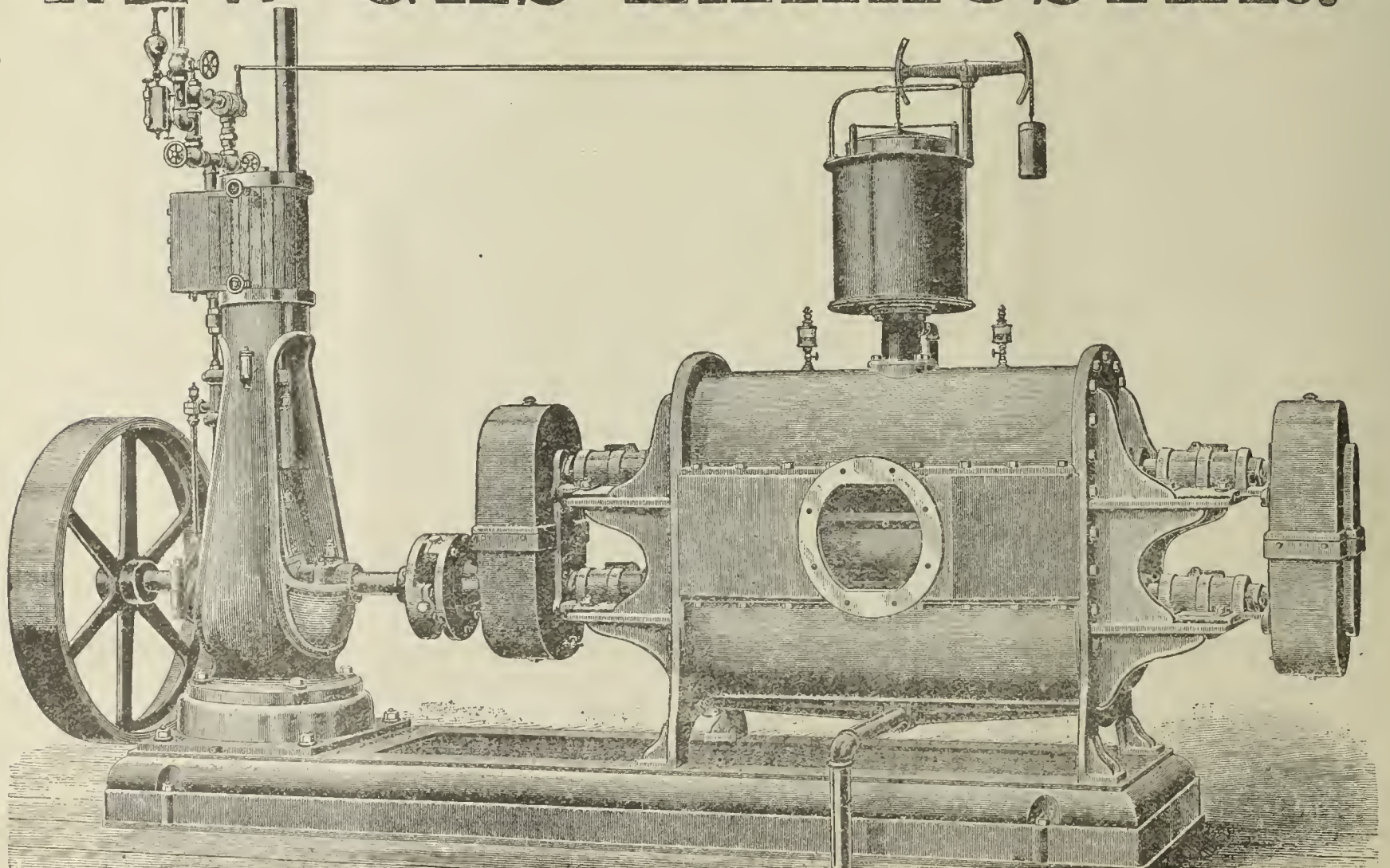

THE P. H. & F. M. ROOTS CO., Patentees and Manufacturers, CONNERSVILLE, IND.

S. S. TOWNSEND, Gen. Agt., 22 Cortlandt St., N. Y.

COOKE & CO., Selling Agts., 22 Cortlanat St., N. Y.

CONNELLY & CO.,

SOLE MANUFACTURERS OF THEIR PATENTED SPECIALTIES.

"IRON SPONGE." Saves money, saves labor, and is the most efficient purifying agent ever offered as a substitute for lime. Now used in every State in the Union, and purifying daily over thirty-five million cubic feet. Should be used in every gas works. Its own saving will pay for it many times over.

AUTOMATIC GOVERNOR. Has been on the market but three years, and in that time has been introduced more generally than any invention ever designed for use in gas works. Over two hundred of them now in use. Sensitive; reliable; perfectly automatic; reduces leakage; satisfies consumers, and gives great relief to the Manager. No gas works is complete without one of these machines.

STEAM JET EXHAUSTER. Designed particularly for small works. Combines Exhaust Tube, Steam Governor Gas Compensator, and Bye-Pass Valves in the most compact form possible; occupies but little space; uses very little steam; operated by ordinary workmen; saves formation of carbon in retorts; increases yield 10 to 15 per cent. Specially adapted for mixing air with oil gas. No works too small to use them profitably.

Prices given on all our specialties delivered at any point in the United States. Correspondence solicited.

CONNELLY & CO., No. 111 Broadway, New York City.

WILBRAHAM GAS EXHAUSTER

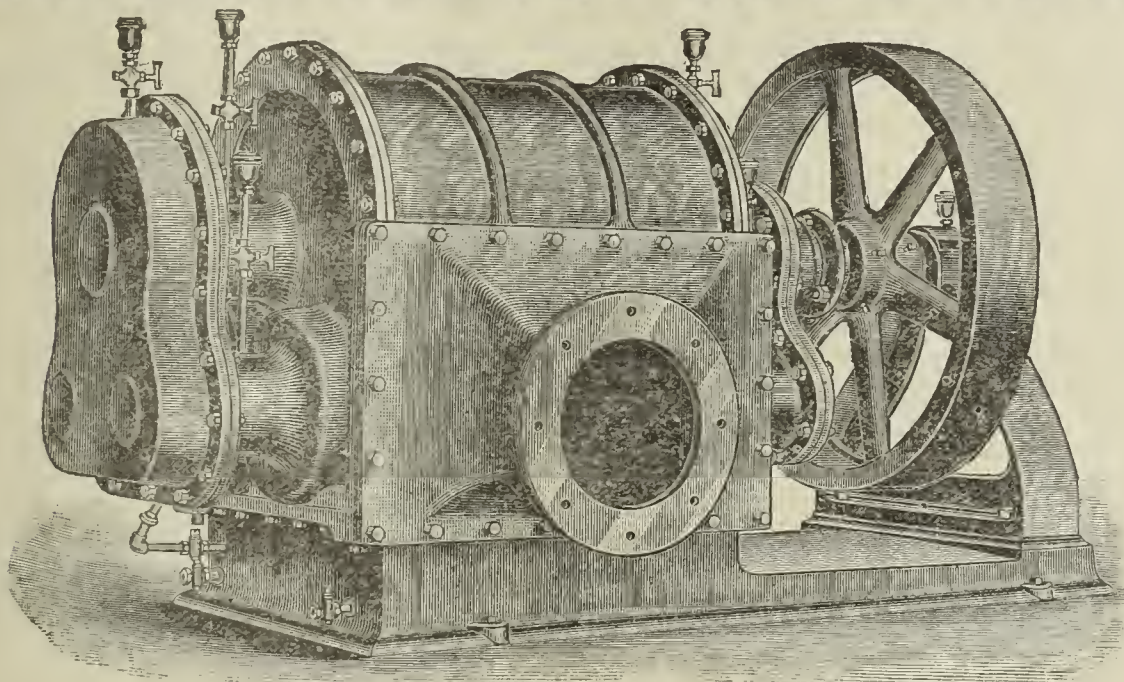

WILBRAHAM BROS.,
PHILADELPHIA, PA.

JARVIS ENGINEERING CO.,

61 Oliver St., Boston, Mass.

CONTRACTORS FOR ERECTING

COMPLETE STEAM OUTFITS FOR ELECTRIC LIGHTING STATIONS.

Steel Boilers set with Jarvis Pat. Boiler Setting

To burn COKE SCREENINGS for Fuel.

ARMINGTON & SIMS CO. ENGINES,

Belted direct to Dynamos, without using Shafting.

SEND FOR CIRCULARS.

REFERENCES.—Charlestown Gas & Electric Light Co., Charlestown, Mass.; Schenectady Gas & Electric Light Co., Schenectady, N. Y.; Brookline Gas Co., Brookline, Mass.

Practical Electric Lighting

By A. BROMLEY HOLMES, A.M.I.C.E.

With 87 Illustrations. Third Edition. Price, \$1.00

Electric Light Primer

By CHARLES L. LEVEY.

A simple and comprehensive Digest of all the most important facts connected with the running of the Dynamo and Electric Lights, with Precautions for Safety, etc.

Price, 50 cents.

A. M. CALLENDER & CO., 42 Pine St., N. Y.

Gasholder Tanks & Gas Works Masonry Complete.

PLANS PREPARED AND ESTIMATES FURNISHED AT SHORT NOTICE.

J. P. WHITTIER, 70 Rush St., near Division Av., Brooklyn, N. Y.

1890 DIRECTORY 1890

OF THE GAS LIGHT COMPANIES of the UNITED STATES & CANADA

Price, \$5.00.

A. M. CALLENDER & CO., No. 42 Pine Street, N. Y. City.



CHAPMAN VALVE MANUFACTURING CO.,

MANUFACTURERS OF

Valves and Gates for Gas, Ammonia, Water, Etc.

Also, Gate Fire Hydrants With and Without Independent Nozzle Valve. All Work Guaranteed.

WORKS & GEN'L OFFICE:
Indian Orchard, Mass.

TREASURER'S OFFICE:
72 Kilby & 112 Milk Sts, Boston, Mass.

LUDLOW VALVE MFG. CO.

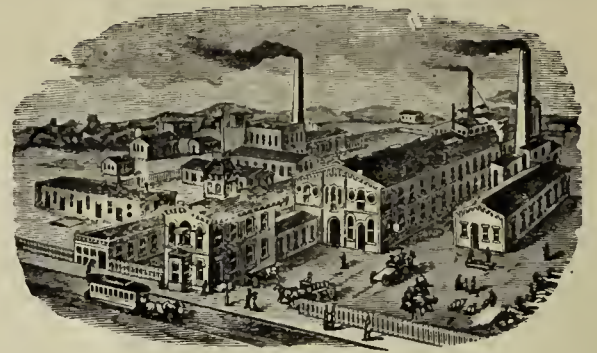

OFFICE AND WORKS,

938 to 954 River Street and 67 to 83 Vail Av.,
TROY, N. Y.

Parson's Steam Blower,

FOR IMPROVING BAD DRAUGHT IN BOILERS, AND FOR BURNING BREEZE OR OTHER WASTE MATERIAL.

PARSON'S TAR BURNER,

FOR UTILIZING COAL TAR AS FUEL.

PARSON'S AIR JET TUBE CLEANER,

FOR CLEANING BOILER TUBES.

These devices are all first-class. They will be sent to any responsible party for trial. No sale unless satisfactory. Manufactured by the WATERTOWN STEAM BLOWER COMPANY.

H. E. PARSON. Supt., 33 & 35 Liberty St., N.Y

MILLS' REVERSIBLE LIME TRAY,

AND

WOODWORK

Of Every Description

NEEDED BY GAS WORKS.

SEND FOR CIRCULAR AND PRICE LIST TO

BARTLETT, HAYWARD & CO.,

Pratt and Scott Streets, Baltimore, Md.

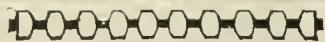
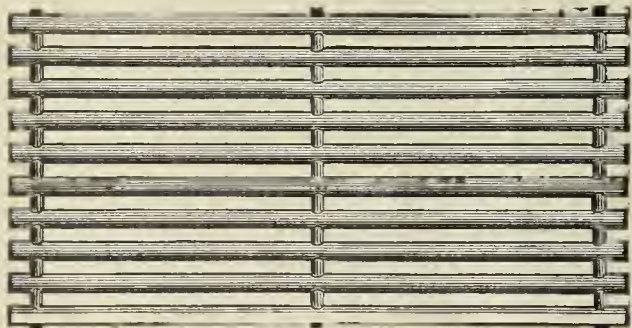

Hydraulic Main Dip Regulators, also Check Valves, Foot Valves, Yard-wash and Fire Hydrants. Send for Circulars.

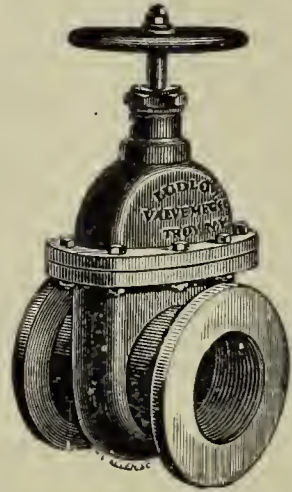

Valves.—Double and Single Gate, 1/2 in. to 48 in., outside and inside Screws. Indicator, etc., for Gas, Water, Steam, and Oil. Send for Circulars.

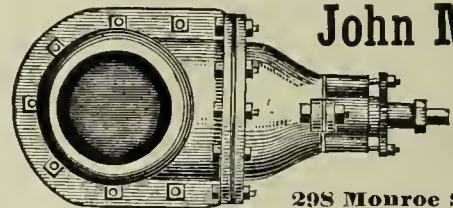

John McLean

Manufacturer

GAS VALVES.

298 Monroe Street, N. Y.

CHURCH'S TRAYS A SPECIALTY.

REVERSIBLE—STRONGEST—MOST DURABLE—MOST EASILY REPAIRED.

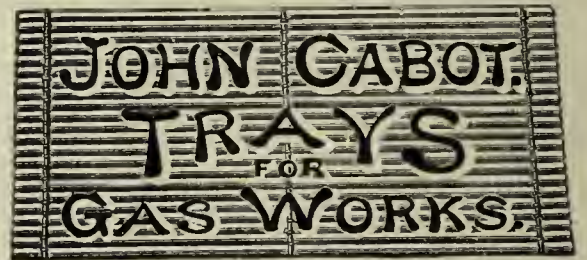

306-310 ELEVENTH AVENUE, NEW YORK.

WE ALSO MAKE THE CHEAPEST AND STRONGEST REVERSIBLE BOLTED TRAYS IN THE MARKET.

VAN DUZEN GAS & GASOLINE ENGINE

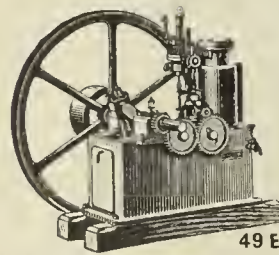

OPERATED with COAL and OTHER MANUFACTURED GASES AND GASOLINE.

RELIABLE AND ECONOMICAL.

Fully Warranted

VAN DUZEN

Gas & Gasoline Engine Co.

49 E. 2d St., Cincinnati, O.

A. MacKinnon Machine Co., Agts., 22 Warren St., N.Y.

The Management of Small Gas Works.

BY C. J. R. HUMPHREYS.

Price, \$1.

Orders to be sent to **A. M. CALLENDER & CO.,**

42 PINE STREET, NEW YORK.

THE CLERK GAS ENGINE CO.,

Main Office, 1012, 1014, 1016, 1018 Filbert St., Philadelphia, Pa.

WM. W. GOODWIN, Prest.

E. STEIN, Sec.

S. LEWIS JONES, Asst. Sec.

A. J. DOTY, Supt.

The utility and convenience of the Gas Engine being no longer an open question, it only remains now for intending purchasers to select the BEST. We claim for the CLERK GAS ENGINE that it is equal to any other manufactured as regards steadiness in running, simplicity, and ease of keeping in repair, and that it gives the greatest amount of power for the least money (both in first cost and expense of running) of any engine made. In support of this claim we refer to the test of the Gas Engines made under the direction of the American Institute of New York, in December, 1885, and heretofore published in these columns. These engines are especially adapted for continuous running under heavy loads, and we can refer to Engines which have run 22 hours a day for months at a time

Made in Sizes of 5, 10, 15, 20, and 25 Horse Power. All Engines Guaranteed for One Year.

ENGINEERS.

P. D. WANNER, Chairman. A. H. MELLERT, Mangr. of Wks.
R. B. KINSEY, Secretary. F. A. KNOPP, Treasurer.

MELLERT FOUNDRY & MACHINE CO. Ltd.
and **READING FOUNDRY CO., Ltd.**
Reading, Pa.



Specials—Flange Pipe, Valves and Hydrants
Lamp Posts, Retorts, etc.
General Foundry and Machine Work.
JOHN FOX, Selling Agent. 160 Broadway, N. Y.

THE OHIO PIPE COMPANY,

MANUFACTURERS OF

Cast Iron Gas & Water Pipe,

BRANCH AND SPECIAL CASTINGS.

Gas-House Bench Castings, Hydraulics, Lamp Posts, Flange Pipe
and Specials, Architectural Castings, Building Columns,
Joists, Cellar Grates, Sash Weights, etc.

GENERAL FOUNDERS AND MACHINISTS.
Columbus, Ohio.

M. J. DRUMMOND,



SPECIAL CASTINGS AND LAMP POSTS.
Office, Corbin Building, 192 Broadway, N. Y.

EMAUS PIPE FOUNDRY.

DONALDSON IRON COMPANY. EMAUS, PA.



MANUFACTURERS OF

CAST IRON PIPE AND SPECIAL CASTINGS
FOR WATER AND GAS.

JOS. R. THOMAS,

No. 42 Pine Street, N. Y. City.

CONSULTING AND CONSTRUCTING
Gas Engineer and Contractor.

PLANS, SPECIFICATIONS, AND ESTIMATES
FURNISHED.

Contracts taken for all Appliances
required at a Gas Works,
Either for New Works or Extensions to Old Plants.

WM. MOONEY

(Successor to WM. FARMER)

No. 94 Liberty St., N. Y. City.

GAS ENGINEER AND CONTRACTOR FOR THE ERECTION
OF GAS WORKS, OR APPARATUS OF ANY
CAPACITY.

Plans and Specifications Furnished.

WM. GARDNER,
Gas Engineer,

Lewis Block, Room 20, Pittsburgh, Pa.

Those who intend to make alterations in existing gas plants, or
who contemplate the erection of new works, will find it to their
interest to open correspondence with the above. Plans made
and estimates furnished.

GAS AND WATER PIPES.

SAM'L R. SHIPLEY, Pres.
HENRY B. CHEW, Tre

GLOUCESTER IRON WORKS,
GLOUCESTER CITY, N. J.



JAS. P. MICHELLON, Sec.
WM. SEXTON, Supt.

Cast Iron Gas & Water Pipes, Stop Valves, Fire Hydrants, Gasholders. &c.

Office, Rooms 61 and 63 Bullitt Building, 131 S. 4th St., Phila., Pa.

WARREN FOUNDRY AND MACHINE CO.,

Established 1856. Works at Phillipsburgh, N. J.

New York Office, 160 Broadway.

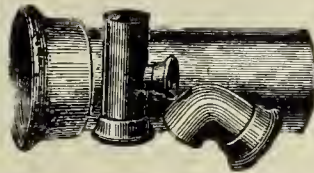

CAST IRON WATER AND GAS PIPE,

FROM TWO TO FORTY-EIGHT INCHES DIAMETER. ALSO, ALL SIZES OF

Flange Pipe for Sugar House and Mine Work. Branches, Bends, Retorts, etc., etc.

DENNIS LONG & COMPANY,

LOUISVILLE, KY.,



Manufacture Exclusively

CAST IRON GAS & WATER PIPE & SPECIAL CASTINGS

OF ALL SIZES.

King's Treatise on Coal Gas.

A standard text-book for the Engineers and Managers of Gas Works, and for all who are concerned
or take an interest in the manufacture and distribution of Coal Gas, and in the utilization of the
Secondary Products resulting therefrom; treating also of the Gas Engine, and of Gas Cooking and
Heating Appliances.

In 3 Vols. Price per Vol., \$10. Sold either by Volume or in Sets.

A. M. CALLENDER & CO., 42 Pine St., N. Y.

RETORTS AND FIRE BRICK.

RETORTS AND FIRE BRICK.

RETORTS AND FIRE BRICK.

J. H. GAUTIER & CO..

CORNER OF
GREENE AND ESSEX STREETS,
JERSEY CITY, N. J.

MANUFACTURERS OF

**Clay Gas Retorts,
Gas House Tiles,
Fire Bricks, Etc. Etc.**

Ground Clay, Fire Brick and
Fire Sand in Barrels,

J. H. GAUTIER. C. E. GREGORY. C. E. GAUTIER.

BROOKLYN
Clay Retort & Fire Brick Works,
(EDWARD D. WHITE & CO.)

Manufacturers of Clay Retorts, Fire Brick,
Gas House and other Tile.

VAN DYKE, ELIZABETH, RICHARDS & PARTITION STS.
Office, 88 Van Dyke St., Brooklyn, N. Y.

LACLEDE FIRE BRICK MFG. CO.,

MANUFACTURERS OF

Fire Brick, Gas Retorts,

AND

ST. LOUIS STANDARD SEWER PIPE.

Blast Furnace and Cupola Linings, every description of Fire
Clay Material, Fire Clay Flue Linings, Chimney Tops
Dry Milled and Crude Fire Clays, etc.

OFFICE AND DEPOT

901, 903, and 905 Pine Street,
ST. LOUIS, MO.

ESTABLISHED IN 1845.

B. KREISCHER & SONS,

OFFICE FOOT OF HOUSTON ST., E. R., N. Y.

Gas Retorts,

TILES, FIRE BRICK.

AND EVERYTHING IN THE FIRE CLAY LINE.

MANHATTAN

FIRE BRICK & ENAMELLED CLAY

RETORT WORKS

ADAM WEBER.

CLAY GAS RETORTS

AND RETORT SETTINGS

FIRE BRICKS, TILES, ETC.,

Office and Works, 15th Street and Avenue C., N. Y.



Works,
LOCKPORT STATION, PA.

— ESTABLISHED 1864. —

JAMES GARDNER, JR.,

Successor to WILLIAM GARDNER & SON.

Office, Rooms 19 & 20, Lewis Block,
PITTSBURGH, PA., P. O. Box 373.

Fire Clay Goods for Gas Works.

H. A. NORTON, No. 4 CENTRAL STREET, BOSTON, MASS., Agent for the New England States.

GEO. C. HICKS, Presl. **CHICAGO** CHAS. A. REED, Sec. & Treas.

Retort and Fire Brick Co.,

MANUFACTURERS OF

Fire Clay Goods of all Kinds,

AND BEST QUALITY ONLY.

Regenerative Furnaces & Water Gas Goods.

45th St., Clark to La Salle, Chicago.

GEROULD'S IMPROVED RETORT CEMENT.

A Cement for patching retorts, putting on mouthpieces, and
making up all bench-work joints. This Cement is mixed ready
or use. Economic and thorough in its work. Fully warranted
a stick. For recommendations and price list address

C. L. GEROULD & CO.,

5 & 7 Skillman St., Brooklyn, N. Y.

Western Agent, H. T. GEROULD, Mendota, Ill.

**Parker-Russell
Mining and Mfg. Co.,**

CITY OFFICE,

Mermod-Jaccard Bldg., Rooms 307 & 308,
Broadway & Locust St., St. Louis, Mo.

PROPRIETORS OF THE

OAKHILL GAS RETORT & FIRE BRICK W'KS

Our immense establishment is now employed almost entirely in
the manufacture of

Materials for Gas Companies

We have studied and perfected three important points. Our re-
torts are made to stand changes of temperature, the strongest
heats of the furnace, and the abrasion of feeding and emptying.
We have the exclusive Agency for the West of the celebrated

**Kloenne-Bredel Full Depth and
Semi-Recuperator Benches,**

And also furnish and build

Our Own Styles Semi-Recuperator Furnaces
for the use of Coal or Coke as fuel.

THOS. SMITH, Prest. AUGUST LAMBLA, Vice-Prest. & Supt.

BALTIMORE

RETORT & FIRE BRICK CO.

MANUFACTORY AT

LOCUST POINT BALTIMORE, MD.

Clay Retorts, Blocks & Tiles

FIRE BRICK, FIRE CLAY,

AND FIRE CEMENT.

Red and Buff Ornamental Tiles and Chim-
ney Tops. Drain and Sewer Pipe (from
2 to 30 inches). Baker Oven Tiles
12 x 12 x 2 and 10 x 10 x 2.

WALDO BROS., 88 WATER ST., BOSTON, MASS

Sole Agents the New England States.

Boston Fire Brick Works Manufacturers of **Gas Retorts and Settings**

Under the Personal Supervision of MR. GEO. C. HICKS late of Chicago.

Fire Clay Goods of all kinds. Akron Sewer Pipe, Lime, Cement, etc. Agts. for the Arc Gas Lamp & Governing Gas Burners.

Send for Circulars and Prices to

FISKE, COLEMAN & CO., Managers, No. 62 Congress Street, Boston, Mass.

FRED. BREDEL, C. E.,

Contractor for the Complete Erection and Equipment of Gas Works.

Sole Proprietor of the KLOENNE PATENTS for North America.

Gas Condensing and Purifying Machine.

Doing all the Work Between Exhauster & Oxide Purifier.

No Condensers Required.

No Naphthaline or Pitch is Formed.

HIGHER CANDLE POWER.

Tar & Ammonia Washers

WATER GAS WASHERS.

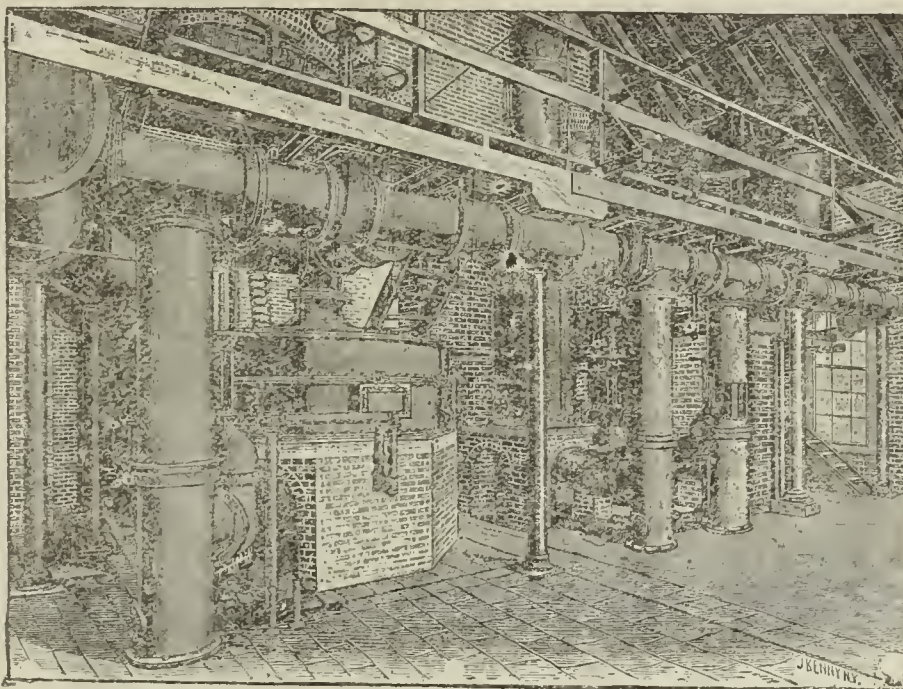

Purifying Machine erected at Cleveland Gas Works, No. 2. Capacity, 1,250,000 Cu. Ft.

RECUPERATIVE FURNACES.

Adapted to Retort Houses With or Without Stage Level.

Over 1,400 Retorts Now in Use in America.

Inclined Retort Benches.

Refers, by permission, to Mr. Eugene Vanderpool, Newark, N. J., and Mr. E. G. Cowdery, Milwaukee, Wis. For further information address

FRED. BREDEL,

No. 208 East Seventeenth Street, - - - New York City.

FLEMMING'S

Generator Gas Furnace

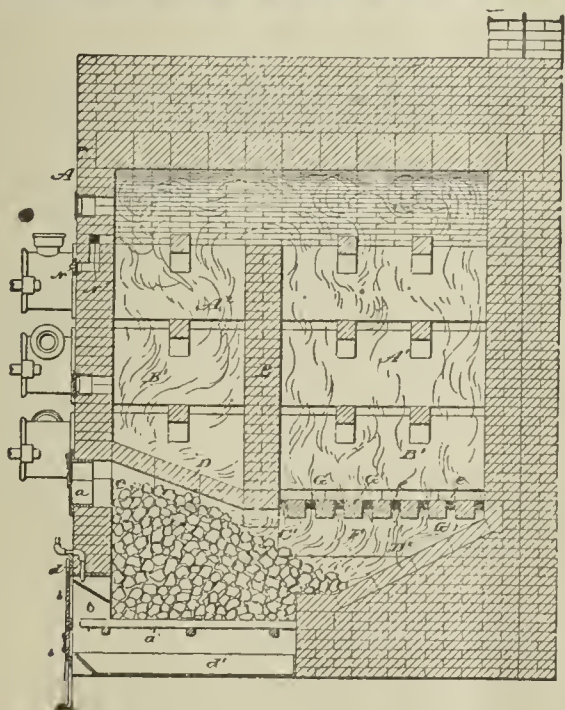

Materials furnished and Benches erected by

J. H. GAUTIER & CO., - Jersey City, N. J.

Address as above, or D. D. FLEMMING, Jersey City, N. J.

HENRY MAURER & SON,

(ESTABLISHED 1856.)

EXCELSIOR FIRE BRICK & CLAY RETORT WORKS

WORKS, Perth Amboy, N. J.

OFFICE, 418 to 422 East 23d St., N. Y.

Clay Gas Retorts, BENCH SETTINGS,

Fire Brick, Tiles, Etc.

GREENOUGH'S "DIGEST OF GAS LAW."

Price, \$5.00.

This is a valuable and important work, a copy of which should be in the possession of every gas company in the country, whether large or small. As a book of reference it will be found invaluable. It is the only work of the kind which has ever been published in this country, and is most complete. Handsomely bound. Orders may be sent to

A. M. CALLENDER & CO., 42 Pine Street, N. Y.

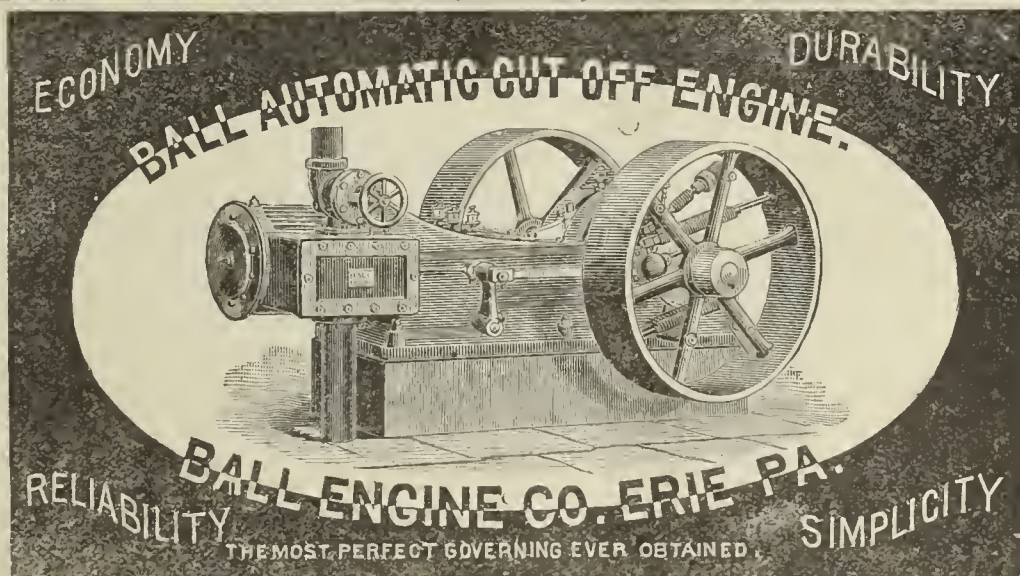

NEWBIGGING'S HANDBOOK FOR GAS ENGINEERS AND MANAGERS.

The present (the fifth) edition marks an important advance on those that have gone before. Considerable additions have been made to the text, and much of it has been rewritten and otherwise improved. Price, cloth, \$6. A. M. CALLENDER & CO., 42 Pine St., N. Y.

DAVIS & FARNUM MFG. CO.,

WALTHAM, MASS.

PRINCIPAL OFFICE AND WORKS, Waltham, Mass.

BOSTON OFFICE, Room 55, Mason Building, 70 Kilby Street.

SINGLE, DOUBLE,
AND
TRIPLE LIFT

Gas holders.

OF ANY CAPACITY.

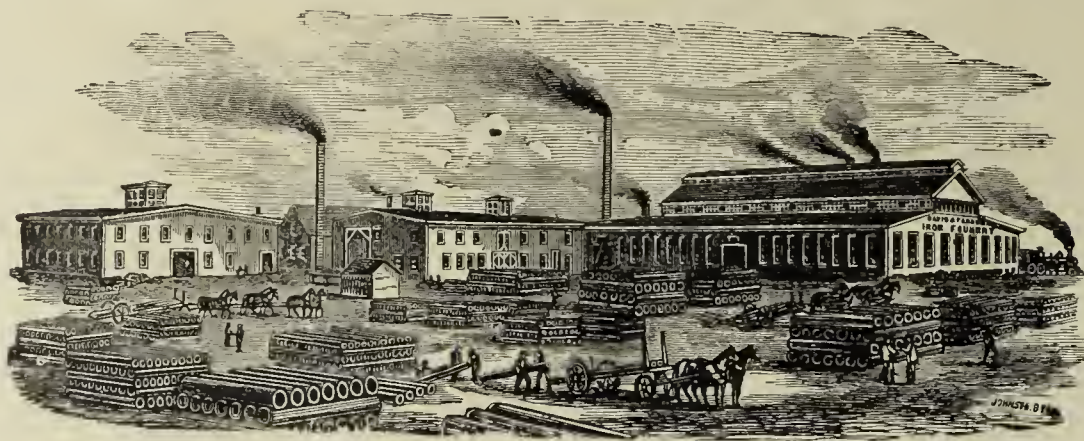

TUBULAR, PIPE,
AND
SINUOUS FRICTION

Condensers.

OF ALL SIZES.

IRON ROOF FRAMES AND FLOORS.

Purifying Boxes, Center Seal or Valve Connections, Bench Work.

Reversible Lime Trays.

SELF-SEALING AND PRESSED STEEL MOUTHPIECE LIDS.

Coke Barrows, Coal Wagons, and all Apparatus Requisite for a Complete Gas Plant.

— ALSO —

Gas and Water Pipe, Flanged Pipe,

Sugar House Work, and Special Castings of all Descriptions.

Established 1861.

Incorporated 1881.

KERR MURRAY MFG. CO.,

FORT WAYNE, IND.

Those who are in need of

Holdings of Gas Works Apparatus of any Description,

AND OF THE LATEST IMPROVEMENTS,

will find it to their interest to

GET AN ESTIMATE FROM US

before placing their order.

As we make a Specialty of this Class of Work, and are Practical Builders and Manufacturers of same,

with our long years of experience in the business,

WE CAN GUARANTEE YOU SATISFACTION.

Estimates, Plans and Specifications Furnished on Application.

BARTLETT, HAYWARD & CO.

Baltimore, Md.

Triple Double, & Single-Lift
GASHOLDERS.

Iron Holder Tanks.

ROOF FRAMES.

Cirders.

BEAMS.

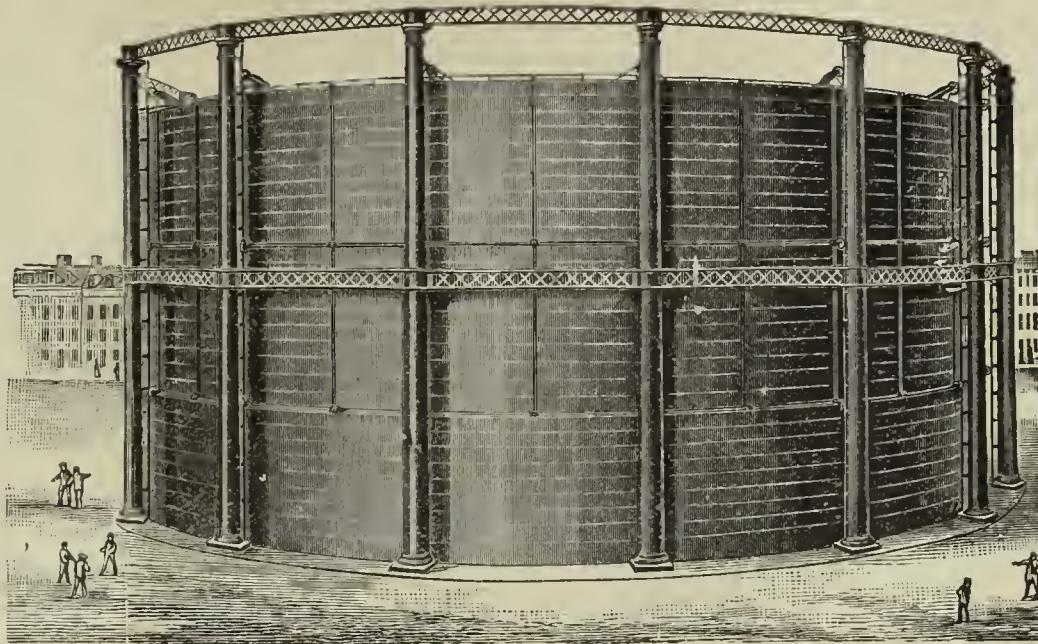

PURIFIERS.

CONDENSERS.

Scrubbers.

BENCH CASTINGS.

OIL STORAGE TANKS.

Boilers.

The Wilkinson Water Gas Process.

THIRTY-CANDLE, NON-CONDENSABLE, FIXED GAS. THE MOST SUCCESSFUL GAS PROCESS IN OPERATION.

Munich Regenerative Furnace, System Drs. Schilling & Bunte.

HAZELTON BOILERS.

Gas Works Designed and Constructed.

Pascal Iron Works. ESTABLISHED 1821. Delaware Iron Works.

MORRIS, TASKER & CO.,

INCORPORATED.

OFFICE, 224 SOUTH THIRD STREET, - - PHILADELPHIA, PA.

CONTRACTORS, BUILDERS, AND MANUFACTURERS OF

Gas, Water & Sugar Works

Bench Castings.

Condensers.

Scrubbers.

Purifiers.

Hyd. Carriages.

Iron Floors,

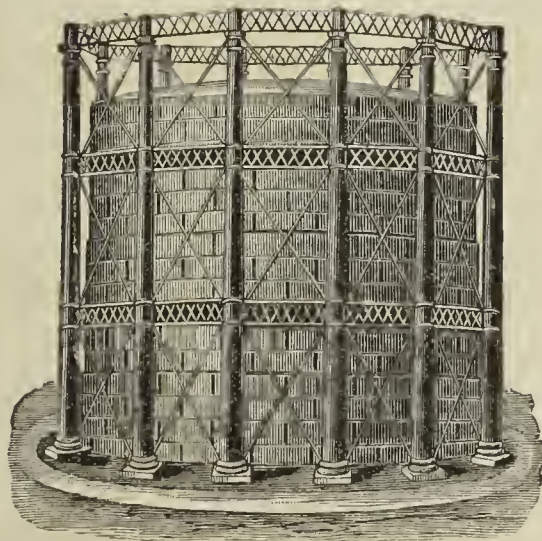

Iron Roofs.

Street Stops,

Valves, etc.

Stand-Pipes.

Water & Oil

Tanks, all Sizes.

Single, Double, and Triple-Lift Gas Holders.

SELF-SEALING RETORT LIDS. STAMPED STEEL RETORT LIDS.

Locomotive Water Columns, Filters, etc. Boiler Tubes, Wrought Iron Pipe & Fittings

Plans, Specifications and Estimates for all kinds of Machinery furnished on application.

Foundries & Works,
MILLVILLE, FLORENCE,
and CAMDEN, N. J.

R. D. WOOD & CO.,

Engineers,
Iron Founders,
and
Machinists.

400 Chestnut St., PHILADELPHIA, PA.

MANUFACTURERS OF

CAST IRON PIPE,

Gas Holders,

SINGLE, DOUBLE, AND TRIPLE LIFTS, WITH
OR WITHOUT WROUGHT IRON
OR STEEL TANKS.

PURIFIERS, CONDENSERS.

Scrubbers.

BENCH WORK.

Iron Floors and Roofs, Plate Girders.

Heavy Loam Castings.

HYDRAULIC WORK.

Lamp Posts, Valves, Etc.

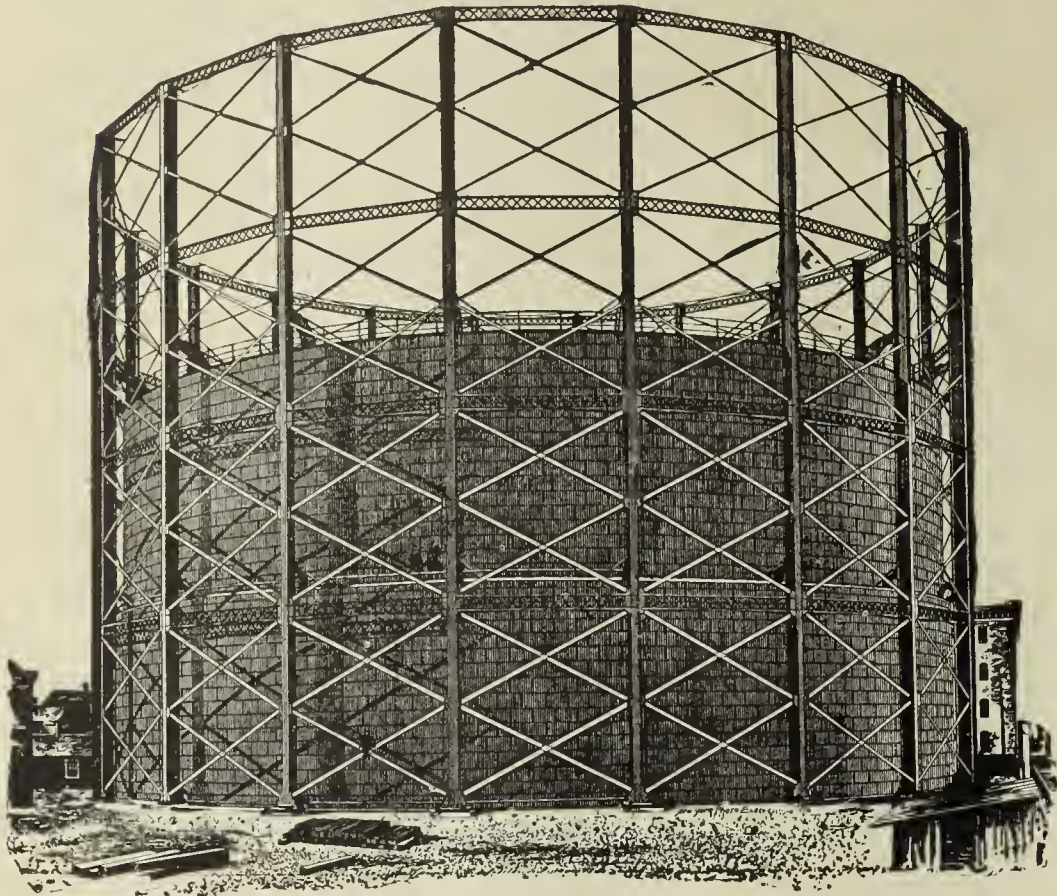

SMITH & SAYRE MFG. COMPANY,

G. G. PORTER, Prest.

245 Broadway, N. Y.

CHAS. W. ISBELL, Sec'y.

Machinery & Apparatus for Gas Works

Drawings, Plans, and Estimates Furnished for the Improvement, Extension, or Alteration of Gas Works, or for the Construction of New Works.

Mackenzie's Patent Rotary and Steam Jet Gas Exhausters, Governors, Compensators, Condensers, Washers, Scrubbers. Isbell's Patent Automatic Street Pressure Governor, Gas and Water Valves, Hydraulic Main Dip Regulator, Bench Castings, etc. Purifying Pipes and "Standard" Scrubbers. Isbell's Patent Self-Sealing Retort Doors.

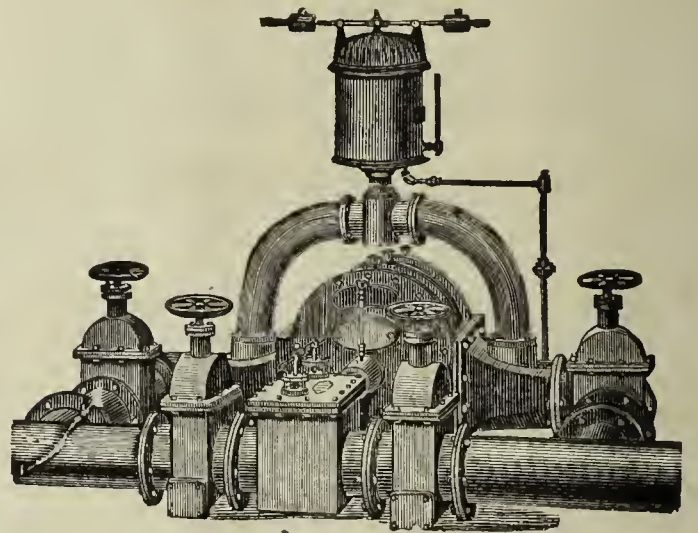

THE BRENNER SELF-SEALING RETORT DOOR.

Simple, Strong, and Durable.

CLOSES ABSOLUTELY TIGHT & IS LOCKED BY A CAM LEVER. ALL NECESSARY ADJUSTMENT FOR WEAR PROVIDED.

BUILT BY

SMITH & SAYRE MFG. CO.,

No. 245 Broadway, - - - New York City.

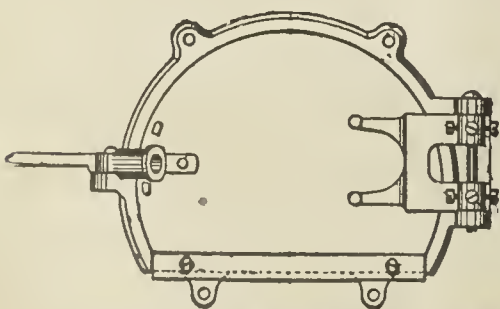

Brenner Self-Sealing Retort Door.

WILLIAM B. LUNDIE, Superintendent of the 42d Street Station of the Consolidated Gas Company, of New York, writes, under date of Jan. 4, 1889:

"We have 320 Brenner Self-Sealing Lids in use at this Station, built by the Smith & Sayre Mfg. Co. They require very little attention, and are the best of the kind that I have seen, giving entire satisfaction."

GAS WORKS APPARATUS AND CONSTRUCTION.

GAS WORKS APPARATUS AND CONSTRUCTION.

JAMES R. FLOYD & SONS,

(SUCCESSORS TO HERRING & FLOYD)

Oregon Iron Works,

W. 20th & 21st. Sts., bet. 10th & 11th Avs.,

NEW YORK CITY.

Engineers and Contractors

FOR THE

CONSTRUCTION OF GAS WORKS.

MANUFACTURERS OF

All Kinds of Castings and General Ironwork

FOR

GAS APPARATUS.

Bench Castings, Regenerative and Half Regenerative Furnace Castings.

Condensers, Scrubbers, Purifiers, Street Drips and Connections,

Valves,

Hydraulic Hoisting Purifier Carriage, Self-Sealing Retort Lids, Improved Valve Stand and Indicator,

Seller's Cement.

Plans, Specifications, and Estimates furnished for Construction of New or Alteration of Old Works.

CONTINENTAL IRON WORKS.

THOS. F. ROWLAND, Prest.

WARREN E. HILL and CHAS. H. CORBETT, V-Prests.

THOS. F. ROWLAND, JR., Sec. & Tr

P. O. Station G., BROOKLYN, N. Y.

ENGINEERS AND MANUFACTURERS OF

Gas Holders

CONDENSERS, SCRUBBERS, VALVES,

PURIFIERS, SELF-SEALING RETORT LIDS

Hydraulic Mains,

And all other articles connected with the manufacture and distribution of Gas.



H. RANSHAW, Prest. & Mangr.

WM. STACEY, Vice-Prest.

T. H. BIRCH, Asst. Mangr.

R. J. TARVIN, Sec. & Treas.

STACEY MFG. CO.,

MANUFACTURERS OF

Single and Telescopic Gasholders,

IRON ROOFS, BRIDGES, LAMP POSTS,

Water and Oil Tanks, Coal Elevator Cars,

COKE CRUSHERS, BENCH CASTINGS,

And all kinds of Wrought and Cast Iron Work used in the erection of Coal and Oil Gas Works Rolling Mill Machinery and Heavy Castings a Specialty.

Foundry:

33, 35, 37 & 39 Mill Street.

Wrought Iron Works:

16, 18, 20, 22, 24 & 26 Ramsey Street:

Cincinnati, Ohio.

Bouton Foundry Co.,

FOUNDERS AND MACHINISTS,

CHICAGO, ILL.

Gas Works Apparatus,

PURIFIERS, CONDENSERS,

Bench Work

SPECIALS, LAMP POSTS,

SCRUBBERS,

Iron Roofs and Floors.

Plans and Estimates furnished for new works or extensions of old works.

1842. **DEILY & FOWLER,** 1890.

Laurel Iron Works.

Address, No. 39 Laurel Street, Philadelphia, Pa.

BUILDERS OF

GASHOLDERS,

Single and Telescopic.

HOLDERS BUILT 1884 to 1888, Inclusive:

Newport, R. I.
Portland, Oregon.
Allegheny, Pa. (2d.)
Atlanta, Ga. (2d.)
N.Y. City (Central Gas Co.)
Lynchburg, Va. (2d.)
Saylesville, R. I.
Rondout, N. Y.
Atlantic City, N. J.
Augusta, Ga.
Waltham, Mass. (2)
Mahanoy City, Pa.
New Castle, Pa.

Long Island City, N. Y.
Macon, Ga.
York, Pa.
Chester, Pa.
Hazleton, Pa. (2d.)
Staten Island, N. Y.
Saugerties, N. Y.
Clinton, Mass. (Lan. Mills)
Chattanooga, Tenn.
Galveston, Texas. (3d.)
Omaha, Neb.
Fort Plain, N. Y.
Brunswick, Ga.

Port Chester, N. Y.
New Rochelle, N. Y.
Salem, N. J. (3d)
Omaha, Neb. (2d)
Lynn, Mass. (2d)
Little Rock, Ark.
Irvington, N. Y.
South Boston, Mass.
Rye, N. Y. (2)
Woodstock, Ont.
Malden, Mass.
Staten Island, N. Y. (2d)
Woodstock, Ont.

Malden, Mass.
Paducah, Ky.
Norwich, Conn.
Seattle, W. T.
San Diego, Cal.
Northern Gas Lt. Co., of
New York, N. Y.
Westerly, R. I.
Willimantic, Conn
Montclair, N. J.
Attleboro, Mass.
Santa Cruz, Cal.
Erie, Pa. (2d)

West Chester, Pa. (2d)
Lancaster, Pa. (3d)
Tacony, Pa. (two)
Mount Vernon, N. Y.
Binghamton, N. Y.
Concord, N. H.
Dover, Del. (2d)
Calais, Me.
New London, Conn. (2d)
West Chester, N. Y.
Bay Shore, L. I.
Washington, D. C.

WM. HENRY WHITE,

No. 32 Pine Street, - - - New York City.

ENGINEER AND CONTRACTOR FOR THE

ERECTION AND EXTENSION OF

GAS, WATER, AND ELECTRIC LIGHT WORKS.

Correspondence with Gas Companies contemplating extending or improving their Plants respectfully invited. Plans and Estimates Furnished.

GAS COALS.

CANNEL COALS.

GAS ENRICHERS.

JAMES D. PERKINS. **PERKINS & CO.,** F. SEAVERNS.
228 & 229 Produce Exchange, New York.

Cable Address, "PERKINS, NEW YORK."

Post Office Box 3695, New York.

GENERAL SALES AGENTS FOR

The Youghiogeny River Coal Company's

OCEAN MINE YOUGHIOGHENY GAS COAL.

HON. W. L. SCOTT, Prest.

M. H. TAYLOR, Vice-Prest.

This Colliery is located at SCOTT HAVEN, PA., in the center of the Youghiogeny Gas Coal District, and produces the ONLY RELIABLE YOUGHIOGHENY COAL for gas purposes. (See Map on p. 87 of this JOURNAL, Feb. 16, '85.)

POINTS OF SHIPMENT,

Locust Point, BALTIMORE.

Pier No. 62, PHILADELPHIA.

Also, SOLE AGENTS for the

**BRECKENRIDGE CANNEL,
OF KENTUCKY.**

Within the past two years we have delivered this Cannel to over ONE HUNDRED COMPANIES IN THIRTY-THREE DIFFERENT STATES, and it is now in use in some of the large Gas Works

On the Continent and in South America,

where it successfully competes with the Australian Shale. It is the ONLY AMERICAN GAS CANNEL of sufficiently high grade to warrant EXPORTATION TO EUROPE AND SOUTH AMERICA, and it is the only economical substitute for OIL OR NAPHTHA. ONE GROSS TON will produce

10,000 Cubic Feet of 75 Candle Gas,	} equal to {	750,000 Candle Feet of Gas, and 26 Bushels of merchantable Coke weighing 900 Pounds
or 12,500 " " 60 " "		
or 15,000 " " 50 " "		

This is the ONLY GAS CANNEL that will produce a REALLY MERCHANTABLE COKE. It can be delivered in parcels of one carload or more to any point in the United States or Canada. Cargo shipments of any size required can be made from NEW YORK, PHILADELPHIA, BALTIMORE, or NEWPORT NEWS. Samples will be sent and particulars of price, etc., forwarded upon application to above address.

JAMES & WILLIAM WOOD,
Gas and Cannel Coal Contractors,

No. 40 St. Enoch Sq., Glasgow. No. 2 Talbot Court, London.

Proprietors of the BATHVILLE COLLIERIES (which produce the celebrated BOGHEAD CANNEL), Shields, Shieldmuir, Drumpeller, and other Collieries. This Firm offer

STANDARD CANNELS,

Unequaled as Gas Enrichers.

Analyses, prices, and all further information furnished on application to
Agency for U.S., Room 70, Nos. 2 & 4 Stone St., N.Y. City.

The Standard Oil Company,

REFINERS OF

NAPHTHA AND GASOLINES.

ALSO MANUFACTURERS OF

A Special Grade of Naptha for Gas Companies

FOR ENRICHING COAL GAS.

Correspondence solicited.

No. 43 Euclid Avenue, Cleveland, Ohio.

To Gas Companies.

We make to order CAP BURNERS to burn any amount under a stated pressure. Send for samples.

Also, SERVICE CLEANERS, DRIP PUMPS, and STREET MAIN PROVING APPARATUS.

C. A. GEFROER,

248 N 8th Street, Phila., Pa.

COKE CRUSHERS.

GAS COALS.

GAS COALS.

Newburgh Orrel Coal and Coke Co.

MINERS AND SHIPPERS OF

STEAM, SMITHING, AND GAS COALS,
Foundry and Crushed Coke.

Home Office, 33 S. Gay Street, Baltimore, Md.

J. HARRY LEE, President.

Shipping Wharves, Locust Point, Baltimore.

The Despard Gas Coal Co.,

MINERS AND SHIPPERS OF

DESPARD GAS COAL,

AND MANUFACTURERS OF

COKE.

MINES, Clarksburg, Harrison Co., W. Va.

WHARVES, Locust Point, Baltimore, Md.

OFFICE, 225 E. German St., " "

ROUSSEL & HICKS, } AGENTS. } BANGS & HORTON,
71 Broadway, N. Y. } 60 Congress St., Boston.

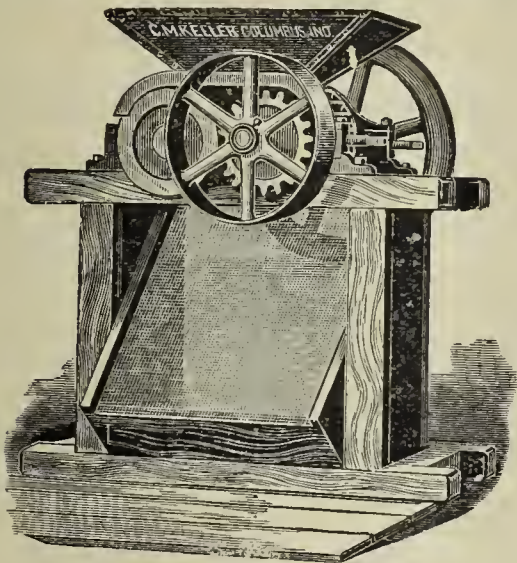

Keller's Adjustable Coke Crusher.

SIMPLE, STRONG, AND DURABLE.

C. M. Keller, Sec. & Supt. Gas Lt. & Coke Co. Columbus, Ind.

Correspondence Solicited.

King's Treatise on Coal Gas.

The most complete work on Coal Gas ever published

Three Vols. Bound, \$30.

BOOKS.

DISTILLATION OF COAL TAR AND
AMMONIACAL LIQUOR.

By GEORGE LUNGE. Price \$12.50.

A TREATISE ON THE COMPARATIVE
COMMERCIAL VALUES OF GAS
COALS AND CANNELS.

By DAVID A. GRAHAM. 8vo., Cloth. Price \$3.

Orders for these books may be sent to this office.

A. M. CALLENDER & CO.,

42 PINE ST., N. Y. CITY

THE
PENN GAS COAL CO.

OFFER THEIR

Coal, Carefully Screened & Prepared for Gas Purposes.

Their Property is located in the Youghiogheny Coal Basin, near Irwin and Penn Stations on the Pennsylvania Railroad, and on the Youghiogheny River.

Principal Office:

209 SOUTH THIRD STREET, PHILA., PA.

Points of Shipment:

Pennsylvania Railroad Piers; Greenwich Wharves, Delaware River; Pier No. 1 (Lower Side), South Amboy, N. J.

Chesapeake & Ohio Railway Coal Agency,

FOR THE SALE OF THE

Superior Kanawha Gas Coals, Cannelton Cannel,
Also, **SPLINT AND STEAM COALS**

From the Kanawha and New River Regions, on the line of the Chesapeake & Ohio R'way.

C. B. ORCUTT, General Agent, - - No. 1 Broadway (Room 217) New York City.

FRANCIS H. JACKSON, Prest.

EDMUND H. McCULLOUGH, V.-Prest.

CHAS. F. GODSHALL, Treas

H. C. ADAMS, Sec.

THE WESTMORELAND COAL CO.

Chartered 1854.

Mines situated on the Pennsylvania and the Baltimore and Ohio Railroads, in Westmoreland County, Penn.

POINTS OF SHIPMENT:

PHILADELPHIA, BALTIMORE, SOUTH AMBOY, N. J.,
WATKINS (SENECA LAKE), N. Y.

Since the commencement of operations by this Company its well-known Coal has been largely used by the Gas Companies of New England and the Middle States, and its character is established as having no superior in gas-giving qualities, and in freedom from sulphur and other impurities.

Principal Office, 224 South 3d St., Phila., Pa.

**The American Gas Engineer
and Superintendent's Handbook.**

By **WILLIAM MOONEY.**

Consisting of Rules, Reference Tables, and Original Matter
Pertaining to the Manufacture, Manipulation, and
Distribution of Illuminating Gas.

350 Pages, Full Gilt Morocco.

\$3.00.

A. M. CALLENDER & CO., 42 Pine St., N. Y.

JOHN J. GRIFFIN & CO.,

Nos. 1513, 1515, 1517 & 1519 Race Street, PHILADELPHIA.
52 Dey St., NEW YORK. 75 N. Clinton St., (FRED. R. PERSONS, Mangr.) CHICAGO.

MANUFACTURERS OF

METERS FOR MEASURING GAS

IN ANY VOLUME.

Provers, Gauges, Registers, Etc., Etc.

EXPERIMENTAL APPARATUS FOR QUANTITATIVE AND QUALITATIVE ANALYSIS.

Careful and Prompt Attention paid to Repairing of all kinds of Meters and Apparatus.

Estimates Cheerfully Furnished.



Dry Gas Meters.

With 40 years' experience and the best facilities for manufacturing, is enabled to furnish reliable work and answer orders promptly.

NATHANIEL TUFTS,

No. 153 Franklin Street, Boston, Mass.,

MANUFACTURER OF

DRY GAS METERS.

Station Meters of any Capacity.

Test and Experimental Meters, Pressure Registers, Pressure Gauges, Pressure and Vacuum Gauges.

METER PROVERS, PHOTOMETERS, STREET LANTERNS, ETC., ETC.

Patent Cluster Lanterns for Street Illumination.

HAROLD J. BELL.

BELL & JONES,

S. LEWIS JONES.

No. 12 North Ninth Street, Philadelphia, Pa. Works at Royersford, Pa.

MANUFACTURERS OF

GAS METERS, STATION AND EXPERIMENTAL METERS,

Meter Provers, Pressure Gauges, and All Other Gas Appliances in Our Line.

WE REPAIR ALL KINDS AND MAKES OF METERS, AND THE WORK GUARANTEED.

High Pressure Meters for Natural Gas, in Iron Cases, guaranteed to stand 300 lbs. Pressure. Gas Cooking and Heating Stoves, Hot Plates, Cake Griddles, Waffle Bakers, Boiling Stoves, Laundry and Tailors' Iron Heaters. Hotel and Cafe Ranges a Specialty.

Correspondence Solicited.

Estimates Furnished.

A. HARRIS.

E. L. HARRIS.

J. A. HARRIS.

Established 1849.

HARRIS BROS. & CO.,

Twelfth and Brown Streets, Philadelphia.

Manufacturers of Wet and Dry Gas Meters,

STATION METERS, METER PROVERS,

EXPERIMENTAL METERS, SHOW OR GLAZED METERS,

Pressure and Vacuum Registers, Gauges, Photometers, Drip and Bell Pumps, Etc., Etc.

PROMPT ATTENTION GIVEN TO ALL ORDERS. METERS THOROUGHLY REPAIRED. ESTIMATES FURNISHED FOR STATION METERS OF ALL SIZES. CORRESPONDENCE SOLICITED.

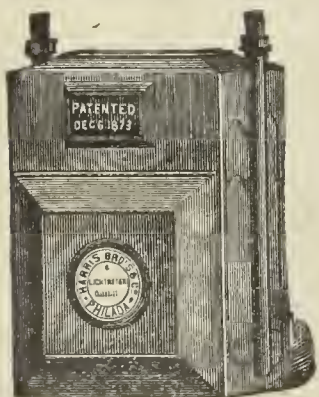

GAS METERS.

GAS METERS.

GAS METERS.

GEO. J. MCGOURKEY, Prest.

WM. H. MCFADDEN, Vice-Prest. (Phila.)

WM. N. MILSTED, Gen. Supt. and Treas. (New York).

WM. H. DOWN, Sec.

THE AMERICAN METER CO.

Established 1834.

Incorporated 1863.

WET AND DRY GAS METERS.

PRESSURE REGISTERS.

METER PROVERS.

STATION METERS.

PRESSURE & VACUUM REGISTERS.

PORTABLE TEST METERS.

EXHAUSTER GOVERNORS.

PRESSURE & VACUUM GAUGES.

EXPERIMENTAL METERS.

DRY CENTER VALVES.

CRESSON GAS REGULATORS.

AMMONIA TEST METERS.

GOVERNORS FOR GAS WORKS.

MARSLAND WATER METERS.

BAR & JET PHOTOMETERS.

Manufactories:

512 West 22d St., N. Y.

Arch & 22d Sts., Phila.

GAS STOVES.

SUGG'S "STANDARD" ARGAND BURNERS,

SUGG'S ILLUMINATING POWER METER,

Wet Meters, with Lizar's "Invariable Measuring" Drum.

Agencies:

177 Elm Street, Cincinnati.

244 & 246 N. Wells Street, Chicago.

510 North Second Street, St. Louis.

222 Sutter Street, San Francisco.

HELME & McILHENNY,

(Established 1848.)

GAS METER MANUFACTURERS,

Nos. 1339 to 1349 Cherry Street, Philadelphia, Pa.,

WET AND DRY GAS METERS. STATION METERS, EXPERIMENTAL METERS, METER PROVERS,

Center Seals, Pressure Registers, Governors, Indicators, Photometers, and all other kinds of Apparatus for use in Gas Works.

FOULIS' PATENT STATION AND DISTRICT GOVERNORS.

REPAIRING DEPARTMENT.—We employ a special force of skilled workmen repairing meters of all makers.

WM. WALLACE GOODWIN, President and Treasurer.

E. STEIN, Vice-President.

H. B. GOODWIN, Secretary and Superintendent.

THE GOODWIN GAS STOVE AND METER CO.,

Successors to W. W. GOODWIN & CO.

1012, 1014 and 1016 Filbert St., Phila., Pa.

113 Chambers St., New York City.

76 Dearborn, St., Chicago, Ills

WALDO BROTHERS, Agents, 88 Water Streets, Boston, Mass.

MANUFACTURERS OF

DRY AND WET GAS METERS,

Station Meters (square, cylindrical, or in staves), Glazed Meters, King's and Sugg's Experimental Meters, Lamp Post Meters, etc., etc. Meter Provers (sizes 2, 5, and 10 feet), Pressure Gauges of all kinds, Pressure Registers, Pressure and Vacuum Registers, Pressure Indicators (sizes 4, 6, and 9 inch), King's Pressure and Vacuum Gauges, Dry and Wet Center Seals, Dry and Wet Governors, Exhauster Governors, Photometers of all descriptions. Letheby's Sulphur and Ammonia Test Apparatus complete. Also, Testing and Chemical Apparatus of all kinds, and of the most perfect description, for all purposes relating to Gas.

Manufacturers of the "SUN DIAL" GAS STOVES, for Cooking and Heating.

Goodwin's Improved Lowe's Jet Photometer.

Agents for Bray's Patent Gas Burners and Lanterns.

Special attention to Repairs of Meters and all Apparatus connected with the business. All work guaranteed first-class in every particular. Orders filled promptly

G. B. EDWARDS, Manager, New York.

S. S. STRATTON, Manager, Chicago.

D. McDONALD & CO.,

GAS METER MANUFACTURERS,

(Established 1854.)

51 Lancaster St., Albany, N. Y.

34 & 36 West Monroe St., Chicago, Ill.

STATION METERS, EXPERIMENTAL METERS, METER PROVERS, PRESSURE & VACUUM REGISTERS, PRESSURE GAUGES, ETC.

Also STAR GAS STOVES, RANGES, and HEATING STOVES.

We use only the very best materials, and employ the most skilled labor, and by our long experience (36 years) and personal supervision of every detail, we feel justified in assuring the public that our goods will give perfect satisfaction. Every Meter emanating from our establishment will bear the State Inspector's BADGE, and will be fully warranted by us. Our Annual and Calendar will be sent to Gas Companies upon application.

GAS INTO POWER,

BY THE

OTTO GAS ENGINE.

GAS POWER.—A Source of Revenue to Gas Companies ready to engage in Electric Lighting, building of Water Works, Electric Street Railways, etc.

Coal for producing Gas is less in amount than that for producing Steam, both being measured on an equal amount of work performed. And, further, with Gas,

50 to 90 per Cent. of Value of Coal is Returned

by sale of Coke and Tar, according to the market value of these products.

Labor for handling fuel is reduced, by its becoming centralized and confined to the gas house, and frequently has not increased after the addition of a power station.

With Gas Power, cost of fuel is strictly limited to the time of use.

MANY VALUABLE
AND RECENT
IMPROVEMENTS.

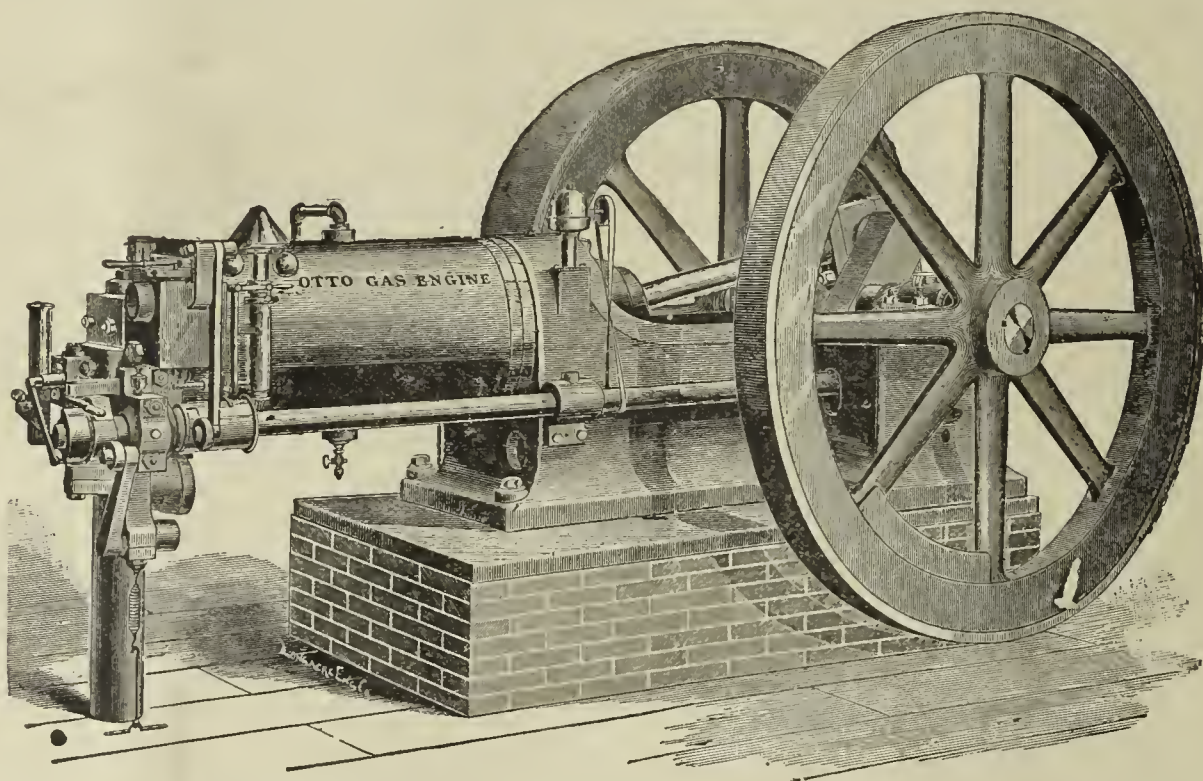

SIZES,
1-3 to 100
HORSE POWER.

Wherever Gas Companies tried Gas Power with Steam Power together in one Station, the use of Steam was subsequently abandoned or restricted, and Gas Power made to take its place.

Where Gas Companies adopt Gas Power for Electric Plants, Water Works, Sewerage, etc., they not only choose the most economical power for their use, but secure to themselves the numerous advantages of increased production, without increase of expense, and benefit thereby their entire manufacture. They induce consumers, by their example, to abandon Steam for Gas Power, and, by establishing special rates, make

Gas Power the Leading Power of To-Day,
AND SOLVE AT ONCE THE QUESTION OF FUEL GAS.

“Otto Gas Engine Works,”

SCHLEICHER, SCHUMM & CO.,

151 Monroe St. (Kent Building), Chicago.

33d & Walnut Sts., Phila.

NEW YORK AGENCY, 18 VESEY STREET.

